

# OPERATION AND PARTS MANUAL



## **MULTIQUIP/STOW MODEL: G-55H GASOLINE VIBRATOR (5.5 HP GASOLINE ENGINE)**

MODEL # \_\_\_\_\_

SERIAL # \_\_\_\_\_

Revision #0 (03/07/06)

THIS MANUAL MUST ACCOMPANY THE EQUIPMENT AT ALL TIMES.

P/N 36397



# WARNING



## **CALIFORNIA — Proposition 65 Warning**

Engine exhaust and some of its constituents, and some dust created by power sanding, sawing, grinding, drilling and other construction activities contains chemicals known to the State of California to cause cancer, birth defects and other reproductive harm. Some examples of these chemicals are:

- Lead from lead-based paints.
- Crystalline silica from bricks.
- Cement and other masonry products.
- Arsenic and chromium from chemically treated lumber.

Your risk from these exposures varies, depending on how often you do this type of work. To reduce your exposure to these chemicals: **ALWAYS** work in a well ventilated area, and work with approved safety equipment, such as dust masks that are specially designed to filter out microscopic particles.

# G-55H GASOLINE VIBRATOR — TABLE OF CONTENTS

## G-55H GASOLINE VIBRATOR

Proposition 65 Warning .....	2
Table Of Contents .....	3
Parts Ordering Procedures .....	4
Specifications .....	5
Safety Message Alert Symbols .....	6-7
Rules For Safe Operation .....	8-9
Operation and Safety Decals .....	10
General Information .....	11
Major Components .....	12
Engine Components .....	13
Inspection .....	14-15
Startup Procedures .....	16-17
Shutdown Procedures .....	17
Operation .....	18-19
Maintenance .....	20-21
Troubleshooting (Gasoline Engine) .....	23
Explanation Of Codes In Remarks Column .....	24
Suggested Spare Parts .....	25

## Honda GX160K1QX2 Engine

Air Cleaner (Dual) Assembly .....	32-33
Camshaft Assembly .....	34-35
Carburetor Assembly .....	36-37
Control Assembly .....	38-39
Crankcase Cover Assembly .....	40-41
Crankshaft/Balancer Assembly .....	42-43
Cylinder Barrel Assembly .....	44-45
Cylinder Head Assembly .....	46-47
Fan Cover Assembly .....	48-49
Flywheel Assembly .....	50-51
Fuel Tank Assembly .....	52-53
Ignition Coil Assembly .....	54-55
Muffler Assembly .....	56-57
Piston Assembly .....	58-59
Recoil Starter Assembly .....	60-61
Gasket Kit Assembly .....	62-63
Labels Assembly .....	64-65

Terms and Condition Of Sale — Parts .....	66
---	----

## COMPONENT DRAWINGS

Nameplate and Decals .....	26-27
Eccentric and Body Assembly .....	28-29
Pivot Assembly .....	30-31

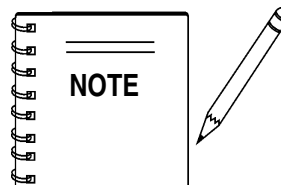

Specification and part number are subject to change without notice.

# PARTS ORDERING PROCEDURES

www.multiquip.com

## Ordering parts has never been easier! Choose from three easy options:



### Order via Internet (Dealers Only):

Order parts on-line using Multiquip's SmartEquip website!

- View Parts Diagrams
- Order Parts
- Print Specification Information



If you have an MQ Account, to obtain a Username and Password, E-mail us at: [parts@multiquip.com](mailto:parts@multiquip.com).

To obtain an MQ Account, contact your District Sales Manager for more information.

Goto [www.multiquip.com](http://www.multiquip.com) and click on **Order Parts** to log in and save!

Use the **internet** and qualify for a **5% Discount** on *Standard orders* for all orders which include complete part numbers.\*

Note: Discounts Are Subject To Change



### Order via Fax (Dealers Only):

All customers are welcome to order parts via Fax.

**Domestic (US) Customers dial:**  
1-800-6-PARTS-7 (800-672-7877)

**Fax** your order in and qualify for a **3% Discount** on *Standard orders* for all orders which include complete part numbers.\*

Note: Discounts Are Subject To Change



**Order via Phone: Domestic (US) Dealers Call:**  
1-800-427-1244

### Non-Dealer Customers:

Contact your local Multiquip Dealer for parts or call 800-427-1244 for help in locating a dealer near you.



**International Customers** should contact their local Multiquip Representatives for Parts Ordering information.

## When ordering parts, please supply:

- |   |  |
|---|--|
| <input type="checkbox"/> Dealer Account Number                                | <input type="checkbox"/> Specify Preferred Method of Shipment:                         |
| <input type="checkbox"/> Dealer Name and Address                              | <input checked="" type="checkbox"/> Fed Ex/UPS <input checked="" type="checkbox"/> DHL |
| <input type="checkbox"/> Shipping Address (if different than billing address) | <input type="checkbox"/> Priority One <input checked="" type="checkbox"/> Truck        |
| <input type="checkbox"/> Return Fax Number                                    | <input type="checkbox"/> Ground  |
| <input type="checkbox"/> Applicable Model Number                              | <input type="checkbox"/> Next Day  |
| <input type="checkbox"/> Quantity, Part Number and Description of Each Part   | <input type="checkbox"/> Second/Third Day  |

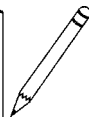
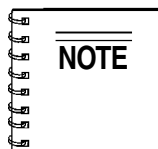

Unless otherwise indicated by customer, all orders are treated as *Standard Orders* and will ship within 24 hours. We will make every effort to ship *Air Shipments* the same day the order is received, if received prior to 2PM PST. *Stock Orders* must be noted on fax or web order form.

WE ACCEPT ALL MAJOR CREDIT CARDS!



# G-55H GASOLINE VIBRATOR — SPECIFICATIONS

**TABLE 1. G55H SPECIFICATIONS**

Vibrator Shaft Speed	10,600 RPMs @ 3600 Engine RPMs
<b>Power Unit</b>	
Dimensions (L x W x H)	24 x 20 x 18 in. (61 x 51 x 46 cm.)
Weight w/ Engine	77 Lbs. (35 Kg)

**TABLE 2. ENGINE SPECIFICATIONS**

<b>TABLE 2. ENGINE SPECIFICATIONS</b>		
Engine	<b>Model</b>	<b>HONDA GX160K1QX2</b>
	Type	4-stroke, Overhead valve, Single Cylinder
	Bore X Stroke	2.7 in. X 1.8 in. (68 mm x 45 mm)
	Displacement	9.9 cu. in. (163 cc)
	Max Output	5.4 bhp(4.0 kW, 5.5 PS) @ 3,600 R.P.M.
	Fuel Tank Capacity	Approx. 0.95 U.S. Gallons (3.6 Liters)
	Standard Idle Speed	1,400 +200/-150 R.P.M.
	Fuel	Unleaded Gasoline
	Lube Oil Capacity	0.63 U.S. Quarts (0.60 Liters)
	Speed Control Method	Centrifugal Fly-weight Type
	Starting Method	Recoil Start
Dimension (L x W x H)		12.0 x 14.3 X 13.2 in. (304 X 362 X 335 mm)
Dry Net Weight		33.1 lbs (15.0 Kg.)

# G-55H GASOLINE VIBRATOR — SAFETY MESSAGE ALERT SYMBOLS

## FOR YOUR SAFETY AND THE SAFETY OF OTHERS!

Safety precautions should be followed at all times when operating this equipment. Failure to read and understand the Safety Messages and Operating Instructions could result in injury to yourself and others.

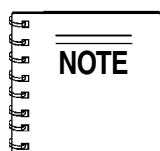

This Owner's Manual has been developed to provide complete instructions for the safe and efficient operation of the **G-55H Gasoline Vibrator**. Refer to the engine manufacturers instructions for data relative to its safe operation.

**Before using this vibrator, ensure that the operating individual has read and understands all instructions in this manual.**

## SAFETY MESSAGE ALERT SYMBOLS

The three (3) Safety Messages shown below will inform you about potential hazards that could injure you or others. The Safety Messages specifically address the level of exposure to the operator, and are preceded by one of three words: **DANGER**, **WARNING**, or **CAUTION**.

### **DANGER**

You **WILL** be **KILLED** or **SERIOUSLY** injured if you **DO NOT** follow directions.

### **WARNING**

You **CAN** be **KILLED** or **SERIOUSLY** injured if you **DO NOT** follow directions.

### **CAUTION**

You **CAN** be **INJURED** if you **DO NOT** follow directions.

## HAZARD SYMBOLS

Potential hazards associated with the operation of the **G-55H Gasoline Vibrator** will be referenced with Hazard Symbols which appear throughout this manual, and will be referenced in conjunction with Safety Message Alert Symbols.

### **WARNING** Lethal Exhaust Gas Hazards

Engine exhaust gases contain poisonous carbon monoxide. This gas is colorless and odorless, and can cause death if inhaled. **NEVER** operate this equipment in a confined area or enclosed structure that does not provide ample free flow air.



### **WARNING** Explosive Fuel Hazards

**Gasoline** is extremely flammable, and its vapors can cause an explosion if ignited. **DO NOT** start the engine near spilled fuel or combustible fluids.



**DO NOT** fill the fuel tank while the engine is running or hot. **DO NOT** overfill tank, since spilled fuel could ignite if it comes into contact with hot engine parts or sparks from the ignition system. Store fuel in approved containers, in well-ventilated areas and away from sparks and flames.

### **WARNING** Burn Hazards

Engine components can generate extreme heat. To prevent burns, **DO NOT** touch these areas while the engine is running or immediately after operations. Never operate the engine with heat shields or heat guards removed.



### **WARNING** Respiratory Hazards

**ALWAYS** wear approved **respiratory** protection when required.



# G-55H GASOLINE VIBRATOR — SAFETY MESSAGE ALERT SYMBOLS

## **CAUTION**

### Rotating Parts Hazards

**NEVER** operate equipment with covers, or guards removed. Keep fingers, hands, hair and clothing away from all moving parts to prevent injury.



## **CAUTION**

### Equipment Damage Hazards

Other important messages are provided throughout this manual to help prevent damage to your equipment, other property, or the surrounding environment.

## **CAUTION**

### Accidental Starting Hazards

**ALWAYS** place the **ON/OFF** switch in the **OFF** position.



## **CAUTION**

### Eye and Hearing Hazards

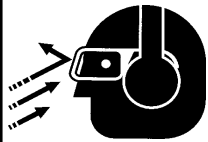

**ALWAYS** wear approved eye and hearing protection.

# G-55H GASOLINE VIBRATOR — RULES FOR SAFE OPERATION

## DANGER

Read this manual!

Failure to follow instructions in this manual may lead to serious injury or even death! This equipment is to be operated by trained and qualified personnel only! This equipment is for industrial use only.

The following safety guidelines should always be used when operating the G-55H Gasoline Vibrator:

### GENERAL SAFETY

- **DO NOT** operate or service this equipment before reading this entire manual.
- This equipment should not be operated by persons under 18 years of age.
- **NEVER** operate this equipment without proper protective clothing, shatterproof glasses, steel-toed boots and other protective devices required by the job.



- **NEVER** operate this equipment when not feeling well due to fatigue, illness or taking medicine.
- **NEVER** operate this equipment under the influence of **drugs** or **alcohol**.



- **ALWAYS** wear proper respiratory (mask), hearing and eye protection equipment when operating the vibrator.
- Whenever necessary, replace nameplate, operation and safety decals when they become difficult to read.
- Manufacture does not assume responsibility for any accident due to equipment modifications.
- **NEVER** use accessories or attachments, which are not recommended by Multiquip for this equipment. Damage to the equipment and/or injury to user may result.

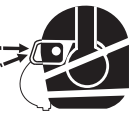

- **NEVER** touch the hot exhaust manifold, muffler or cylinder. Allow these parts to cool before servicing engine or vibrator.

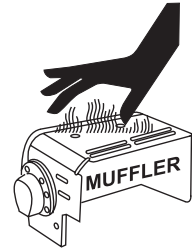

- **High Temperatures** – Allow the engine to cool before adding fuel or performing service and maintenance functions. Contact with **hot!** components can cause serious burns.

- The engine section of this vibrator requires an adequate free flow of cooling air. **NEVER** operate the vibrator in any enclosed or narrow area where free flow of the air is restricted. If the air flow is restricted it will cause serious damage to the vibrator or engine and may cause injury to people. Remember the vibrator's engine gives off **DEADLY** carbon monoxide gas.

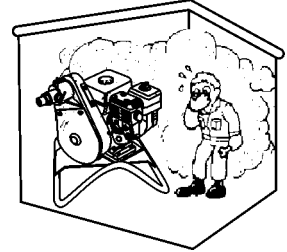

- **ALWAYS** refuel in a well-ventilated area, away from sparks and open flames.
- **ALWAYS** use extreme caution when working with **flammable** liquids. When refueling, **stop the engine** and allow it to cool. **DO NOT smoke** around or near the machine. Fire or explosion could result from fuel vapors, or if fuel is spilled on a hot engine.
- **NEVER** operate the equipment in an explosive atmosphere or near combustible materials. An explosion or fire could result causing severe **bodily harm or even death**.



- Topping-off to filler port is dangerous, as it tends to spill fuel.
- Stop the engine when leaving the vibrator unattended.
- Maintain this equipment in a safe operating condition at all times.
- **ALWAYS** check to make sure the cutting area is clear before starting the engine.
- **ALWAYS** clear the work area of any debris, tools, etc. that would constitute a hazard while the vibrator is in operation.

# G-55H GASOLINE VIBRATOR — RULES FOR SAFE OPERATION

- **ALWAYS** stop the engine before servicing, adding fuel and oil.
- **NEVER** run engine without air filter. Severe engine damage may occur.
- **ALWAYS** service air cleaner frequently to prevent carburetor malfunction.
- **ALWAYS** be sure the operator is familiar with proper safety precautions and operations techniques before using.
- **ALWAYS** store equipment properly when it is not being used. Equipment should be stored in a clean, dry location out of the reach of children.
- **DO NOT** operate this equipment unless all guards and safety devices are attached and in place.
- **CAUTION** must be exercised while servicing this equipment. Rotating and moving parts can cause injury if contacted.
- Keep all *inexperienced* and *unauthorized* people away from the equipment at all times.
- Unauthorized equipment modifications will void all warranties.
- **NEVER** pour or spray water over the engine.
- Test the **ON/OFF** switch for the gasoline engine before operating. The purpose of these switches is to shut down the engine of the vibrator.
- Refer to the *HONDA Engine Owner's Manual* for engine technical questions or information recommended by Multiquip for this equipment. Damage to the equipment and/or injury to user may result.

## TRANSPORTING

- **ALWAYS** shutdown engine before transporting.
- Tighten fuel tank cap securely and close fuel cock to prevent fuel from spilling.
- **ALWAYS** use proper lifting techniques when using or moving the vibrator motor, flexible shaft or vibrator head assembly.

## MAINTENANCE

- **NEVER** lubricate components or attempt service on a running vibrator.
- **ALWAYS** allow the vibrator a proper amount of time to cool before servicing.
- Keep the vibrator in proper running condition.
- Fix damage to the vibrator immediately and always replace broken parts.
- Dispose of hazardous waste properly. Examples of potentially hazardous waste are used motor oil, fuel and fuel filters.
- **DO NOT** use food or plastic containers to dispose of hazardous waste.

## EMERGENCIES

- **ALWAYS** know the location of the nearest *fire extinguisher* and *first aid kit*.

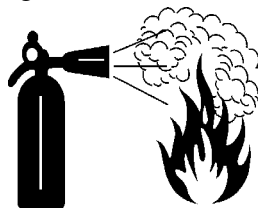

- In emergencies *always* know the location of the nearest phone or *keep a phone on the job site*. Also know the phone numbers of the nearest *ambulance*, *doctor* and *fire department*. This information will be invaluable in the case of an emergency.

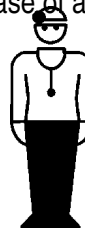

# G-55H GASOLINE VIBRATOR — OPERATION AND SAFETY DECALS

## Operation And Safety Decals

The MQ/STOW G-55H Gasoline Vibrator is equipped with a number of operation and safety decals (Figure 1). These decals are provided for operator safety and maintenance information. Should any of these decals become unreadable, replacements can be obtained from your dealer.



P/N 36521



P/N 11247 (ISO Black)



P/N 21302

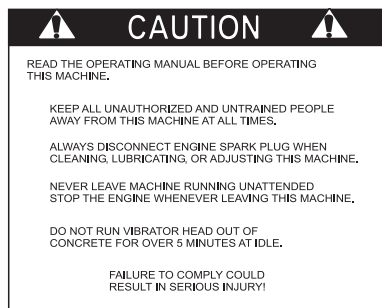

P/N 25883-001

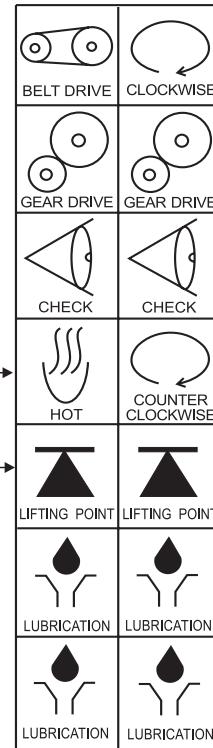

A →  
"HOT"

B →  
"LIFTING POINT"

DECAL SHEET  
INTL STDS ISO  
P/N 11246



CONTACT PARTS  
DEPARTMENT

Figure 1. Operation and Safety Decals

# G-55H GASOLINE VIBRATOR — GENERAL INFORMATION

## General Information

The G-55H Gasoline Vibrator employs a 5.5 HP Honda engine. It comes standard with a quick-disconnect coupling and an eccentric belt tensioner.

The G-55H power unit utilizes a sturdy frame which enables the engine to operate in a 360° rotation.

When operating the vibrator always wear rubber insulated gloves and boots. Safety glasses are also recommended.

## Tips

- Keep the bending radius of the flexible hose to a minimum during use.
- Avoid starting the unit with the vibrator head immersed in the concrete mix. After the engine has started, immerse the vibrator head into concrete mix.
- Excessive wear to the vibrating head can result from misuse. **DO NOT** allow the head to vibrate against already hardened concrete or steel used in reinforcement.
- **NEVER** drop or knock the vibrator head against any hard objects. This will prevent any damage the eccentric or bearings contain within the head.
- **ALWAYS** rinse or wipe off any wet concrete before it dries or hardens on any part of the unit (engine, shaft, or head).

Before operating this gasoline powered vibrator, the operator must **read** and **understand** the contents of the operation manual. Failure to read this manual could result in severe bodily harm and damage to the equipment.



## Theory Of Concrete Vibration

This G-55H vibrator is designed for the **compaction** of concrete by removal of air pockets and voids.

The purpose of vibration is to set the particles in the fresh concrete in motion, thereby reducing the friction between the particles and giving the mixture the mobile quality of a thick fluid so that gravity and the displacement of entrapped air will cause it to settle easily into place.

By consolidating the concrete quickly, "stiffer" or "drier" mixes can be poured than would otherwise be possible. It has been proven that (up to a point) the drier the concrete, (that is, the less water in it), the better the quality throughout and the greater the strength. Drier mixes also make the concrete more water tight, increase resistance to weathering, and create a better bond between concrete and reinforcement.

Because vibration causes much of the entrapped air in the concrete to rise to the surface, honeycombing is prevented. Also, vibration eliminates most of the air pockets between the concrete and the vertical forms.

## G-55H GASOLINE VIBRATOR — MAJOR COMPONENTS

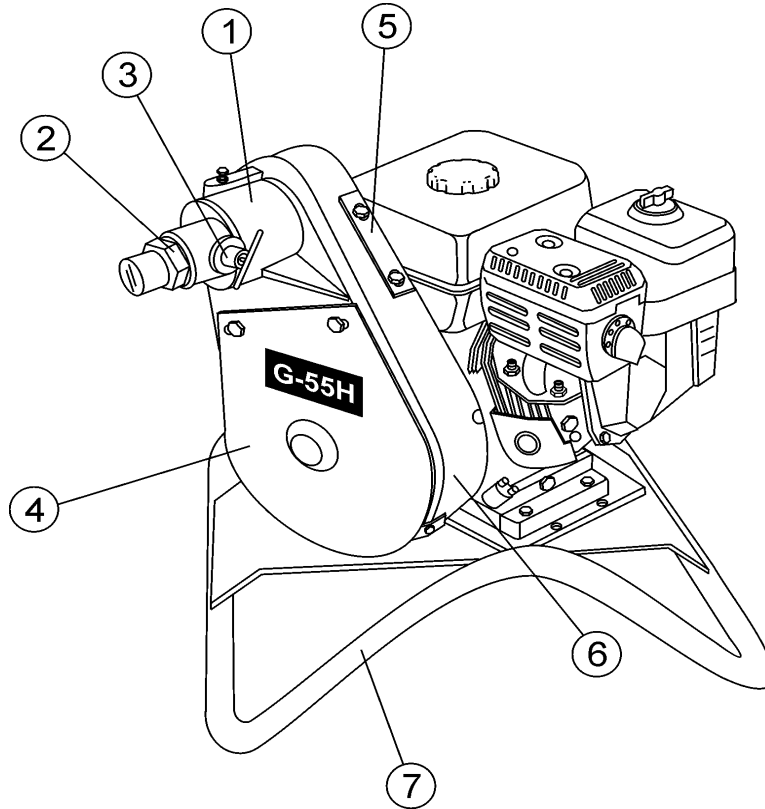

Figure 2. G-55H Gasoline Vibrator Components

Figure 2 shows the location of the components and general maintenance parts. The function of each component is described below:



1. **Eccentric Bell End** – Supports the spindle shaft and upper pulley which drives the vibration function of the G-55H. The flexible shaft and quick disconnect are inserted into the open end of the Eccentric Bell.
2. **328V Quick Disconnect** – Connect the flexible shaft to the quick disconnect and insert into the eccentric bell. This allows for rapid removal of the flexible shaft end from the vibrator base.
3. **Quick Disconnect Lock Pin** – Pull up on the lock pin and pull the flexible shaft out to release the quick disconnect from the eccentric bell. To insert a flexible shaft, pull up on the lock pin and insert the quick disconnect fitting. Release the pin and turn the fitting until the lock pin drops into one of the holes on the fitting end.
4. **Front Belt Guard** – Attaches to the V-belt housing and prevents access to the pulleys or V-belts while the vibrator is running. **DO NOT** operate the vibrator with this cover removed.
5. **Rear Belt Guard** – Attaches to the V-belt housing and prevents access to the pulleys or V-belts while the vibrator is running. **DO NOT** operate the vibrator with this cover removed.
6. **V-belt Housing** – Encloses the pulley's and v-belts. Access is provided through openings in the front and rear of the housing.
7. **Vibrator Support Stand** – Allows the vibrator base to sit upright. A pivot mechanism allows the base to freely pivot in a complete 360 degree circle for operators convenience.

# G-55H GASOLINE VIBRATOR — ENGINE COMPONENTS

## 5.5 HP Honda Gasoline Engine

The engine (Figure 3) must be checked for proper lubrication and filled with fuel prior to operation. Refer to the manufacturer's engine manual for instructions & details of operation and servicing. The engine shown above is a **HONDA** engine. Operation for other types of engines may vary.

1. **Fuel Filler Cap** – Remove this cap to add unleaded gasoline to the fuel tank. Make sure cap is tightened securely. **DO NOT** over fill.

 <b>DANGER</b>	<b>Explosive Fuel Hazard</b>
<p>Adding fuel to the tank should be done only when the engine is stopped and has had an opportunity to cool down. In the event of a fuel spill, <b>DO NOT</b> attempt to start the engine until the fuel residue has been completely wiped up, and the area surrounding the engine is dry.</p>	
	

2. **Throttle Lever** – Used to adjust engine RPM speed (lever advanced forward **SLOW**, lever back toward operator **FAST**).
3. **Engine ON/OFF Switch** – **ON** position permits engine starting, **OFF** position stops engine operation.
4. **Recoil Starter (pull rope)** – Manual-starting method. Pull the starter grip until resistance is felt, then pull briskly and smoothly.
5. **Fuel Valve Lever** – **OPEN** to let fuel flow, **CLOSE** to stop the flow of fuel.
6. **Choke Lever** – Used in the starting of a cold engine, or in cold weather conditions. The choke enriches the fuel mixture.
7. **Air Cleaner** – Prevents dirt and other debris from entering the fuel system. Remove wing-nut on top of air filter cannister to gain access to filter element.

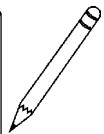
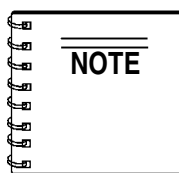

Operating the engine without an air filter, with a damaged air filter, or a filter in need of replacement will allow dirt to enter the engine, causing rapid engine wear.

8. **Spark Plug** – Provides spark to the ignition system. Clean spark plug once a week.

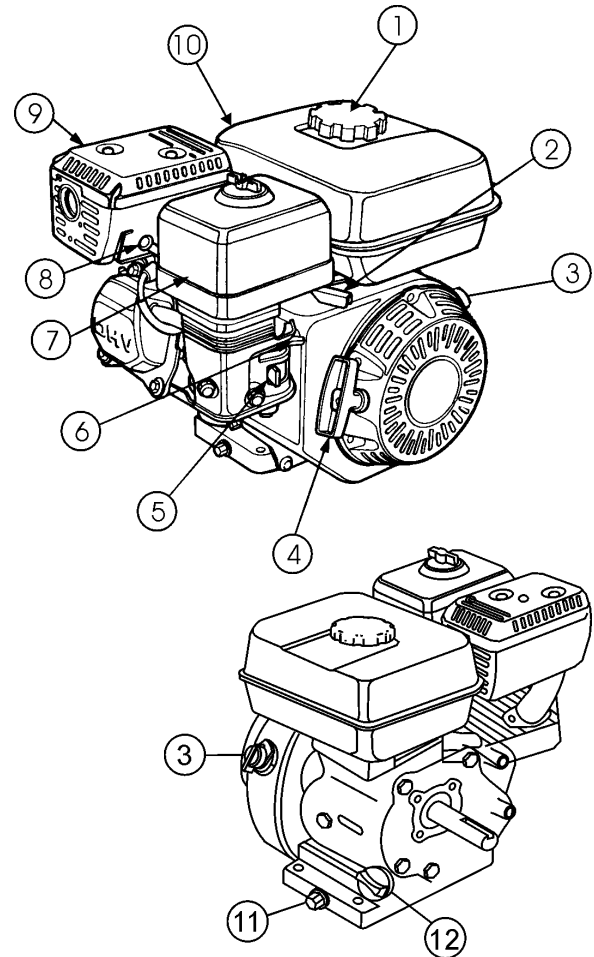



Figure 3. Honda GX160T1QX2 Engine Components

9. **Muffler** – Used to reduce noise and emissions.

 <b>WARNING</b>	<b>Burn Hazard</b>
<p>Engine components can generate extreme heat. To prevent burns, <b>DO NOT</b> touch these areas while the engine is running or immediately after operating. <b>NEVER</b> operate the engine with the muffler removed.</p>	
	

10. **Fuel Tank** – Holds unleaded gasoline. For additional information refer to engine owner's manual.
11. **Oil Drain Plug** – Remove this plug to remove oil from the engine's crankcase.
12. **Dipstick/Oil Filler Cap** – Remove this cap to determine if the engine oil is low. Add oil through this filler port as recommended in Table 3.

# G-55H GASOLINE VIBRATOR — INSPECTION

## CAUTION

### Inspection & Maintenance Safety

**NEVER** place hands or feet inside the belt guard cover while the engine is running. **ALWAYS** shut the engine down before performing any kind of maintenance service on the unit.



## CAUTION

### Eyesight and Hearing Protection

**ALWAYS** wear approved eye and hearing protection before inspecting, operating or servicing the vibrator.

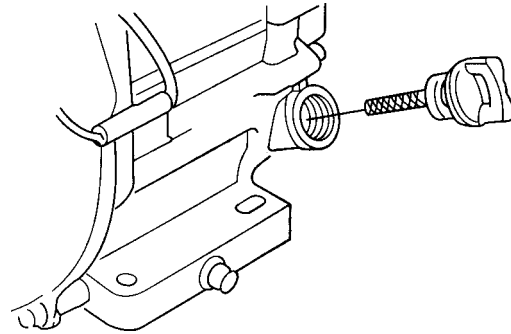
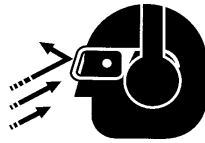

Figure 4. Engine Oil Dipstick (Removal)

3. Insert and remove the dipstick without screwing it into the filler neck. Check the oil level shown on the dipstick.
4. If the oil level is low (Figure 5), fill to the edge of the oil filler hole with the recommended oil type (Table 3). Maximum oil capacity is 0.63 quarts (.60 liters).

### Before Starting

Before starting and operating the G-55H Gasoline Vibrator, perform the following:

- Read safety instructions at the beginning of manual.
- Clean the vibrator, removing dirt and dust, particularly the engine cooling air inlet, carburetor and air cleaner.
- Check the air filter for dirt and dust. If air filter is dirty, replace air filter with a new one as required.
- Check carburetor for external dirt and dust. Clean with dry compressed air.
- Check fastening nuts and bolts for tightness.
- Check the engine oil level of the engine.
- Check the fuel level of the engine.
- Check the tension and condition of the vibrator power unit's V-belts.

### Engine Oil Check

1. To check the engine oil level, place the vibrator on secure level ground with the engine stopped.
2. Remove the filler dipstick from the engine oil filler hole (Figure 4) and wipe clean.

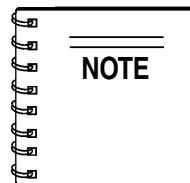

Reference manufacturer engine manual for specific servicing instructions.

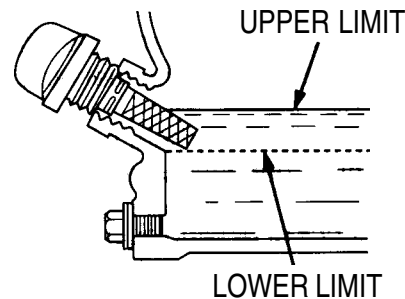

Figure 5. Engine Oil Dipstick (Oil Level)

Table 3. Oil Type

Season	Temperature	Oil Type
Summer	25°C or Higher	SAE 10W-30
Spring/Fall	25°C~10°C	SAE 10W-30/20
Winter	0°C or Lower	SAE 10W-10

# G-55H GASOLINE VIBRATOR — INSPECTION

## **WARNING**

### Explosive Fuel Hazards

**Gasoline** is extremely flammable, and its vapors can cause an explosion if ignited. **DO NOT** start the engine near spilled fuel or combustible fluids.



**DO NOT** fill the fuel tank while the engine is running or hot. **DO NOT** overfill tank, since spilled fuel could ignite if it comes into contact with hot engine parts or sparks from the ignition system. Store fuel in approved containers, in well-ventilated areas and away from sparks and flames.

1. Remove the gasoline cap located on top of fuel tank.
2. Visually inspect to see if fuel level is low. If fuel is low, replenish with unleaded fuel.
3. When refueling, be sure to use a strainer for filtration. **DO NOT** top-off fuel. Wipe up any spilled fuel.

### V-Belt Check

A worn or damaged V-belt can adversely affect the performance of the vibrator.

1. Unscrew the bolts securing the front belt guard to the belt housing
2. Inspect the belts for defects or wear.
3. If a V-belt is defective or worn, replace the V-belt as outlined in the maintenance section of this manual.

### Moving the Vibrator

Even though the vibrator is lightweight, always use two people when lifting the vibrator or moving the unit around the jobsite.

# G-55H GASOLINE VIBRATOR — START-UP PROCEDURES

This section is intended to assist the operator with initial start-up. It is extremely important that this section be read carefully before attempting to use the vibrator in the field.



**DO NOT** use your vibrator until this section is thoroughly understood.

## WARNING

### General Safety

Failure to understand the operation of this vibrator could result in **severe damage** to the vibrator or **personal injury**.

See Figures 2 and 3 for the location of any control referenced in this manual.

## CAUTION

### Respiratory Hazard



**NEVER** operate the vibrator in a confined area or enclosed area structure that does not provide ample **free flow of air**.

## Starting the Engine

1. Place the engine **fuel valve lever** (Figure 6) to the **ON** position.

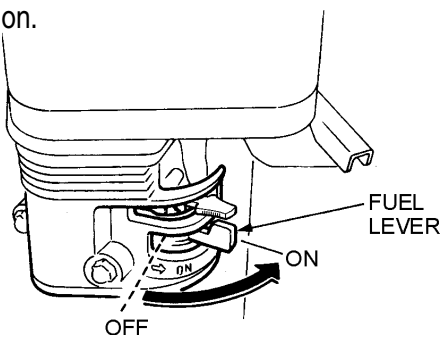

Figure 6. Engine Fuel Valve Lever

2. Place the engine **throttle lever** (Figure 7) to the **IDLE** or **SLOW** position.

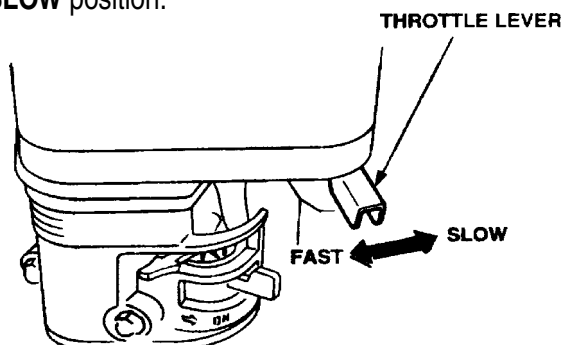

Figure 7. Throttle Lever

3. Place the engine **choke lever** (Figure 8) in the **CLOSED** position if starting a **cold engine**. Place the **choke lever** in the **OPEN** position if starting a **warm engine** or the **temperature is warm**.

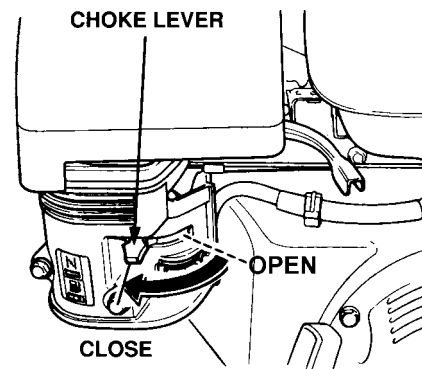

Figure 8. Engine Choke Lever

5. Place the engine **ON/OFF switch** (Figure 9) in the **ON** position.

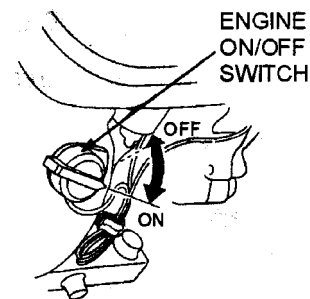

Figure 9. Engine ON/OFF Switch

6. Grasp the **recoil starter grip** (Figure 10) and slowly pull it out. The resistance becomes the hardest at a certain position, corresponding to the compression point. Pull the starter grip briskly and smoothly for starting.

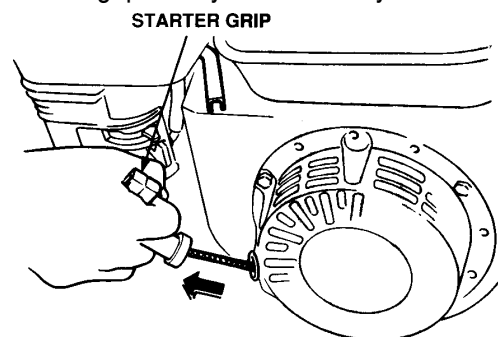

Figure 10. Starter Grip

# G-55H GASOLINE VIBRATOR — START-UP/SHUTDOWN PROCEDURES

7. If the engine has started, slowly return the choke lever (Figure 6) to the **OPEN** position. If the engine has not started repeat steps 1 through 6.
8. Before the vibrator is placed into operation, immerse the vibrator head into the concrete and run the engine for several minutes. Check for fuel leaks, and noises that would associate with a loose V-belt cover or component.

## **CAUTION**

### **Vibrator Head Overheating Hazard**

The vibrator head is cooled by the concrete. Operation of the vibrator head in air longer than 2 minutes will cause overheating of the bearings which result in premature head failure.

9. To begin use, move the throttle lever (Figure 6) toward the **FAST** position.

## **Stopping The Engine**

1. Move the throttle lever to the **IDLE** or **SLOW** position (Figure 11) and run the engine for three minutes at low speed.
2. After the engine cools, turn the engine **start/stop switch** to the **OFF** position (Figure 11).

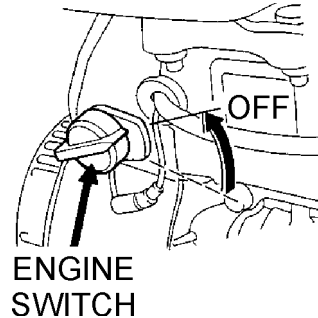

**Figure 11. Engine ON/OFF Switch (OFF Position)**

3. Close the **fuel shut-off valve** (Figure 12) by moving the fuel valve lever to the **OFF** position.

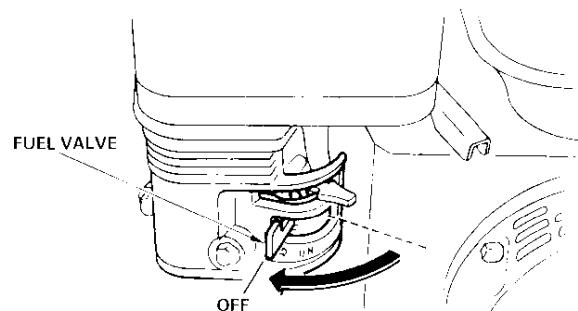

**Figure 12. Fuel Valve Lever (OFF Position)**

# G-55H GASOLINE VIBRATOR — OPERATION

## Operation

**Read** all the safety instructions carefully. Safety instructions will be found throughout this manual and on the vibrator motor. Keep all safety information available, accessible, and in good, readable condition.

- Make certain that the flexible shaft is properly attached to the motor and the head to the flexible shaft.
- Use the flexible shaft in as straight a position as possible.
- **Do not** bend the flexible shaft sharply at any point. Sharp bends may cause a permanent kink, requiring early replacement of the flexible shaft.

## Equipment Combination Information

The following Equipment Combination Chart shows all of the recommended connections between the gasoline vibrator and the vibrator head.

TABLE 5. EQUIPMENT COMBINATIONS			
COUPLING	SHAFT	HEAD	MAX SHAFT LENGTH
382V Q.D	382V	1400 vib.	28 ft. (132.3 cm)
		1700 vib.	
		2100 vib.	21 ft. (99.2 cm)



### WARNING

### Equipment Hazard

Using head attachments not listed above may create a hazardous condition when using the vibrator.

The G-55H Gasoline Vibrator, flexible shafting, and head are shipped from the factory ready for assembly. Follow the instructions listed below when connecting these parts before using the gasoline vibrator.

## Connecting the 382V Flexible Shaft

1. Connect the 382V Flexible Shaft to the Quick Disconnect coupling (Figure 13).
2. Pull **UP** on the lock pin and slide the shaft and quick disconnect assembly into the eccentric end bell and release the lock pin.
3. Twist the shaft assembly to make sure that the lock pin is seated in one of the 3 tapered holes on the quick disconnect coupling.

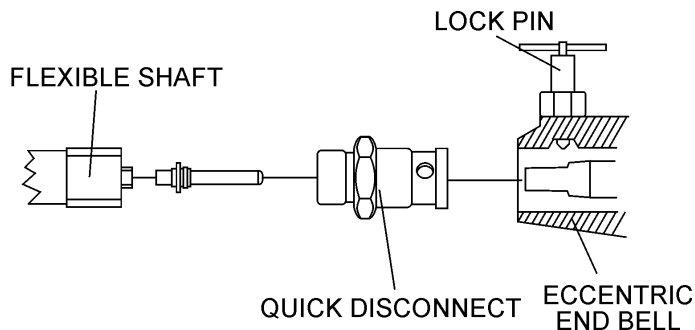

Figure 13. Couplings

## Connecting the vibrator head to the flexible shaft

1. Clean the mating parts threads with Loctite Primer "T".
2. Allow to dry several minutes before applying a ring of Loctite No.271 to the middle of the casing threads.
3. Screw the head tightly to the flexible shaft casing and wait for 1 hour before using. The threads are left hand, turn counter-clockwise to tighten. An equivalent brand of anaerobic sealant may be used.

# G-55H GASOLINE VIBRATOR — OPERATION

1. Start the engine as previously described and proceed to insert the vibrator head into the concrete.
2. The concrete is normally placed into the forms in layers about 12 to 18 inches thick in a manner which forms a fairly level surface. The vibrator head is inserted vertically into the top of the pile.
3. When the surface has become fairly level, the vibrator head then should be immersed and generally moved in the pattern shown in (Figure 14).

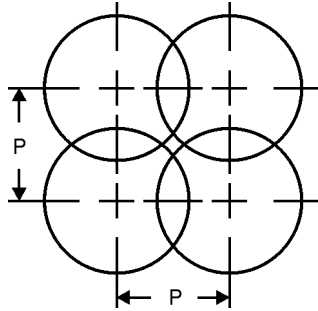

**Figure 14. Compaction Coverage with 50% Radial Overlap**

Use the flexible shaft in as straight a position as possible and do not bend the flexible shaft sharply at any point. Sharp bends may cause a permanent kink, requiring early replacement of the flexible shaft.

**! CAUTION Shaft Overload Hazard**

If the shaft begins to helix (buckle) excessively during operation, stop and investigate. This is an indication of an overload condition.

**! CAUTION Vibrator Head Overheating Hazard**

The vibrator head is cooled by the concrete. Operation of the vibrator head in air longer than 2 minutes will cause overheating of the bearings which result in premature head failure.

**TABLE 4. HEAD AND P-DIMENSIONS**

HEAD	1400	1700	2100
P-DIMENSION	8 in. (31.4 mm)	12 in. (47.2 mm.)	14 in. (55.1 mm)

- Immerse the head for 5 to 10 seconds, (until air stops rising), and then withdraw it slowly to let the concrete fill the void left by the vibrator head.
- The vibrator head should be completely below the surface when vibrating to keep the head cool.
- When vibrating a thin horizontal slab, the vibrator head can be used in a horizontal position.

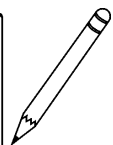
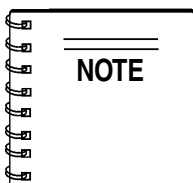

**DO NOT** insert the vibrator head into the side of the pile to make the concrete flow as this practice can cause segregation of the aggregate from the mortar.

# G-55H GASOLINE VIBRATOR — MAINTENANCE

## Maintenance Instructions

To receive trouble-free service from your G-55H gasoline vibrator, follow these instructions, as well as the instructions contained in the engine operating manual, flexible shaft operations manual and the vibrator head operations manual.

The 382V flexible shafting requires cleaning and lubrication every 100 hours of operation. Refer to the flexible shaft operation and parts manual for maintenance instructions.

Vibrator heads should be inspected and relubricated every 100 hours of operation. Refer to the vibrator head operation and parts manual for maintenance instructions.

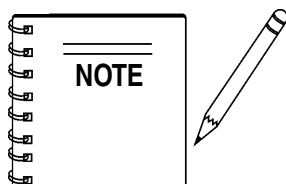

Heat should be used to break down the loctite while you unthread the head from the shaft. This will prevent possible damage to the threads from the loctite.

## ! WARNING

### Disabling the Engine for Maintenance

Whenever assembling, lubricating, or adjusting any part of the gasoline vibrator make certain to stop the engine, disconnect the spark plug wire and secure it away from the spark plug.

## Daily

Thoroughly remove dirt and oil from the engine and control area. Clean or replace the air cleaner elements as necessary. Check and retighten all fasteners as necessary. Check the gearbox for oil leaks. Repair or replace as needed.

## Weekly

- Remove the fuel filter cap and clean the inside of the fuel tank.
- Remove or clean the filter at the bottom of the tank.

- Remove and clean the spark plug (Figure 24), then adjust the spark gap to 0.024 ~0.028 inch (0.6~0.7 mm). This unit has electronic ignition, which requires no adjustments.

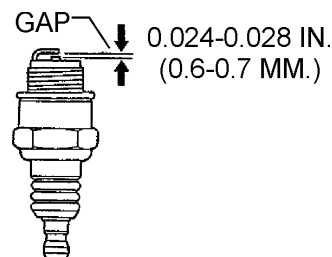

Figure 15. Spark Plug Gap

## Engine Oil

- Drain the engine oil when the oil is **warm** as shown in Figure 25.
- Remove the oil drain bolt and sealing washer and allow the oil to drain into a suitable container.
- Replace engine oil with recommended type oil as listed in Table 3. For engine oil capacity, see Table 2 (engine specifications). **DO NOT** overfill.
- Install drain bolt with sealing washer and tighten securely.

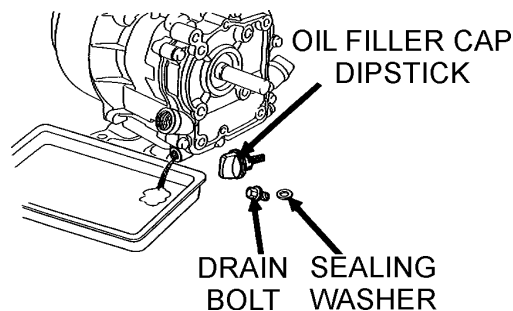
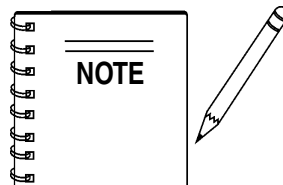

Figure 16. Engine Oil (Draining)



Dispose of used oil properly. **DO NOT** pour used oil on the ground, down a drain, or throw in the trash.

Used oil can generally be taken to your local recycling center or service station for reclamation. Follow all required environmental rules and regulations required in your area concerning the disposal of hazardous waste such as used oil and oil filters.

# G-55H GASOLINE VIBRATOR — MAINTENANCE

## Engine Air Cleaner

1. Remove the air cleaner cover and foam filter element as shown in Figure 26.
2. Tap the paper filter element (Figure 26) several times on a hard surface to remove dirt, or blow compressed air [not exceeding 30 psi (207 kPa, 2.1 kgf/cm<sup>2</sup>)] through the filter element from the air cleaner case side. **NEVER** brush off dirt. Brushing will force dirt into the fibers. Replace the paper filter element if it is excessively dirty.
3. Clean foam element in warm, soapy water or nonflammable solvent. Rinse and dry thoroughly. Dip the element in clean engine oil and completely squeeze out the excess oil from the element before installing.



**DANGER**

**Explosive Hazard**

**DO NOT** use gasoline as a cleaning solvent to avoid creating the risk of fire or an explosion.

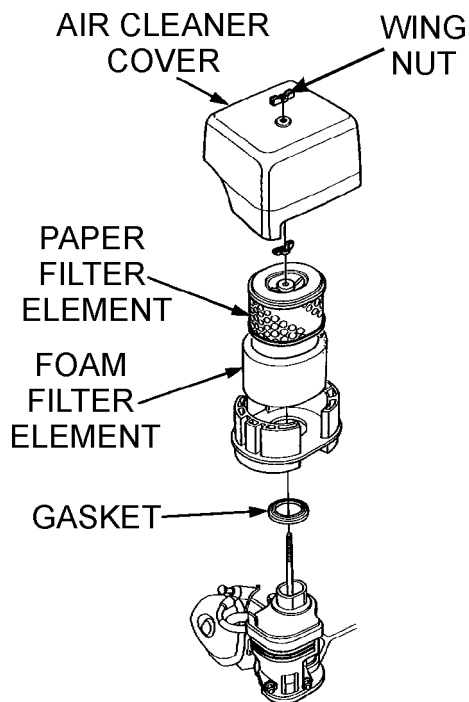

Figure 17. Engine Air Cleaner

## V-Belt Tension

The belt can be tightened by rotating the eccentric countershaft assembly clockwise. When the belts are properly tensioned, they should deflect approximately 5 to 10mm when 5-10 pounds of force is applied centrally between the pulleys. Lock the countershaft in place with the locking screw and wing nut.

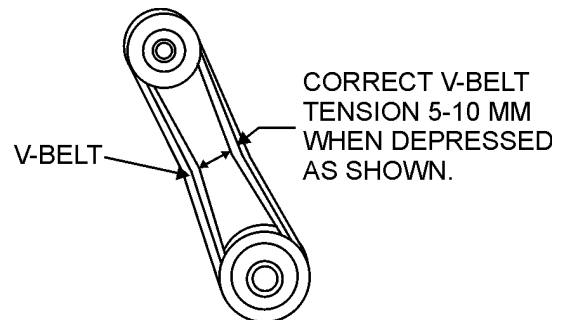

Figure 18. V-Belt Tension

## Lubrication

### Quick Disconnect Lock

A small amount of any lightweight oil should be used on the locking mechanism to help keep concrete from sticking and also to lubricate the locking pin and spring.

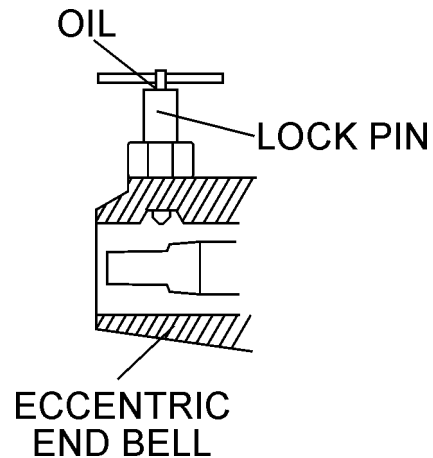

Figure 19. Quick Disconnect Lock

### Pivot Assembly

Grease with a pressure gun as required.

# G-55H GASOLINE VIBRATOR — TROUBLESHOOTING (ENGINE)

**TABLE 5. TROUBLESHOOTING (ENGINE)**

SYMPTOM	POSSIBLE CAUSE	SOLUTION
Difficult to start, "fuel is available, but no SPARK at spark plug".	Spark plug bridging?	Check gap, insulation or replace spark plug.
	Carbon deposit on spark plug?	Clean or replace spark plug.
	Short circuit due to deficient spark plug insulation?	Check spark plug insulation, replace if worn.
	Improper spark plug gap?	Set to proper gap.
	Ignition coil defective?	Replace ignition coil.
Difficult to start, "fuel is available, and SPARK is present at the spark plug".	ON/OFF switch is shorted?	Check switch wiring, replace switch.
	Improper spark gap, points dirty?	Set correct spark gap and clean points.
	Condenser insulation worn or short circuiting?	Replace condenser.
	Spark plug wire broken or short circuiting?	Replace defective spark plug wiring.
Difficult to start, "fuel is available, spark is present and compression is normal".	Wrong fuel type?	Flush fuel system, and replace with correct type of fuel.
	Water or dust in fuel system?	Flush fuel system.
	Air cleaner dirty?	Replace air cleaner.
	Choke Open?	Close Choke.
Difficult to start, "fuel is available, spark is present and compression is low".	Suction/exhaust valve stuck or protruded?	Re-seat valves.
	Piston ring and/or cylinder worn?	Replace piston rings and/or piston.
	Cylinder head and/or spark plug not tightened properly?	Torque cylinder head bolts and spark plug.
	Head gasket and/or spark plug gasket damaged?	Replace head and/or spark plug gaskets.
No fuel present at the carburetor.	Fuel not available in fuel tank (tank empty)?	Fill with correct type of fuel.
	Fuel filter clogged?	Replace fuel filter.
	Fuel tank cap breather hole clogged?	Clean or replace fuel tank cap.
	Air in fuel line?	Bleed fuel line.



# G-55H VIBRATOR — EXPLANATION OF CODE IN REMARKS COLUMN

The following section explains the different symbols and remarks used in the Parts section of this manual. Use the help numbers found on the back page of the manual if there are any questions.

The contents and part numbers listed in the parts section are subject to change **without notice**. Multiquip does not guarantee the availability of the parts listed.

Sample Parts List:

NO.	PART NO.	PART NAME	QTY.	REMARKS
1	12345	BOLT .....	1 ....	INCLUDES ITEMS W/*
2*		WASHER, 1/4 IN. ....		NOT SOLD SEPARATELY
2*	12347	WASHER, 3/8 IN. ....	1 ....	MQ-45T ONLY
3	12348	HOSE .....	A/R ..	MAKE LOCALLY
4	12349	BEARING .....	1 ....	S/N 2345B AND ABOVE

## NO. Column

**Unique Symbols** - All items with same unique symbol (\*, #, +, %, or >) in the number column belong to the same assembly or kit, which is indicated by a note in the “Remarks” column.

**Duplicate Item Numbers** - Duplicate numbers indicate multiple part numbers are in effect for the same general item, such as different size saw blade guards in use or a part that has been updated on newer versions of the same machine.

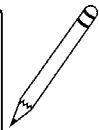
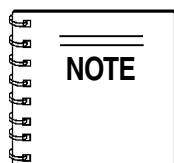

When ordering a part that has more than one item number listed, check the remarks column for help in determining the proper part to order.

## PART NO. Column

**Numbers Used** - Part numbers can be indicated by a number, a blank entry, or TBD.

TBD (To Be Determined) is generally used to show a part that has not been assigned a formal part number at time of publication.

A blank entry generally indicates that the item is not sold separately or is not sold by Multiquip. Other entries will be clarified in the “Remarks” Column.

## QTY. Column

**Numbers Used** - Item quantity can be indicated by a number, a blank entry, or A/R.

A/R (As Required) is generally used for hoses or other parts that are sold in bulk and cut to length.

A blank entry generally indicates that the item is not sold separately. Other entries will be clarified in the “Remarks” Column.

## REMARKS Column

Some of the most common notes found in the “Remarks” Column are listed below. Other additional notes needed to describe the item can also be shown.

**Assembly/Kit** - All items on the parts list with the same unique symbol will be included when this item is purchased.

Indicated by:

“INCLUDES ITEMS W/(unique symbol)”

**Serial Number Break** - Used to list an effective serial number range where a particular part is used.

Indicated by:

“S/N XXXXX AND BELOW”

“S/N XXXX AND ABOVE”

“S/N XXXX TO S/N XXX”

**Specific Model Number Use** - Indicates that the part is used only with the specific model number or model number variant listed. It can also be used to show a part is NOT used on a specific model or model number variant.

Indicated by:

“XXXXX ONLY”

“NOT USED ON XXXX”

**“Make/Obtain Locally”** - Indicates that the part can be purchased at any hardware shop or made out of available items. Examples include battery cables, shims, and certain washers and nuts.

**“Not Sold Separately”** - Indicates that an item cannot be purchased as a separate item and is either part of an assembly/kit that can be purchased, or is not available for sale through Multiquip.

## **G-55H GASOLINE VIBRATOR 1 TO 3 UNITS W/HONDA GX160K1QX2 ENGINE**

<u>Qty.</u>	<u>P/N</u>	<u>Description</u>
3 .....	9807956846 .....	SPARK PLUG
3 .....	17210ZE2505 .....	ELEMENT, AIR CLEANER
1 .....	28462ZE2W11 .....	ROPE STARTER
1 .....	17620ZH7023 .....	CAP, W/GASKET FUEL FILLER
4 .....	16052 .....	V-BELT 3VX335

# G-55H GASOLINE VIBRATOR — NAMEPLATE AND DECALS

NAMEPLATE AND DECALS.

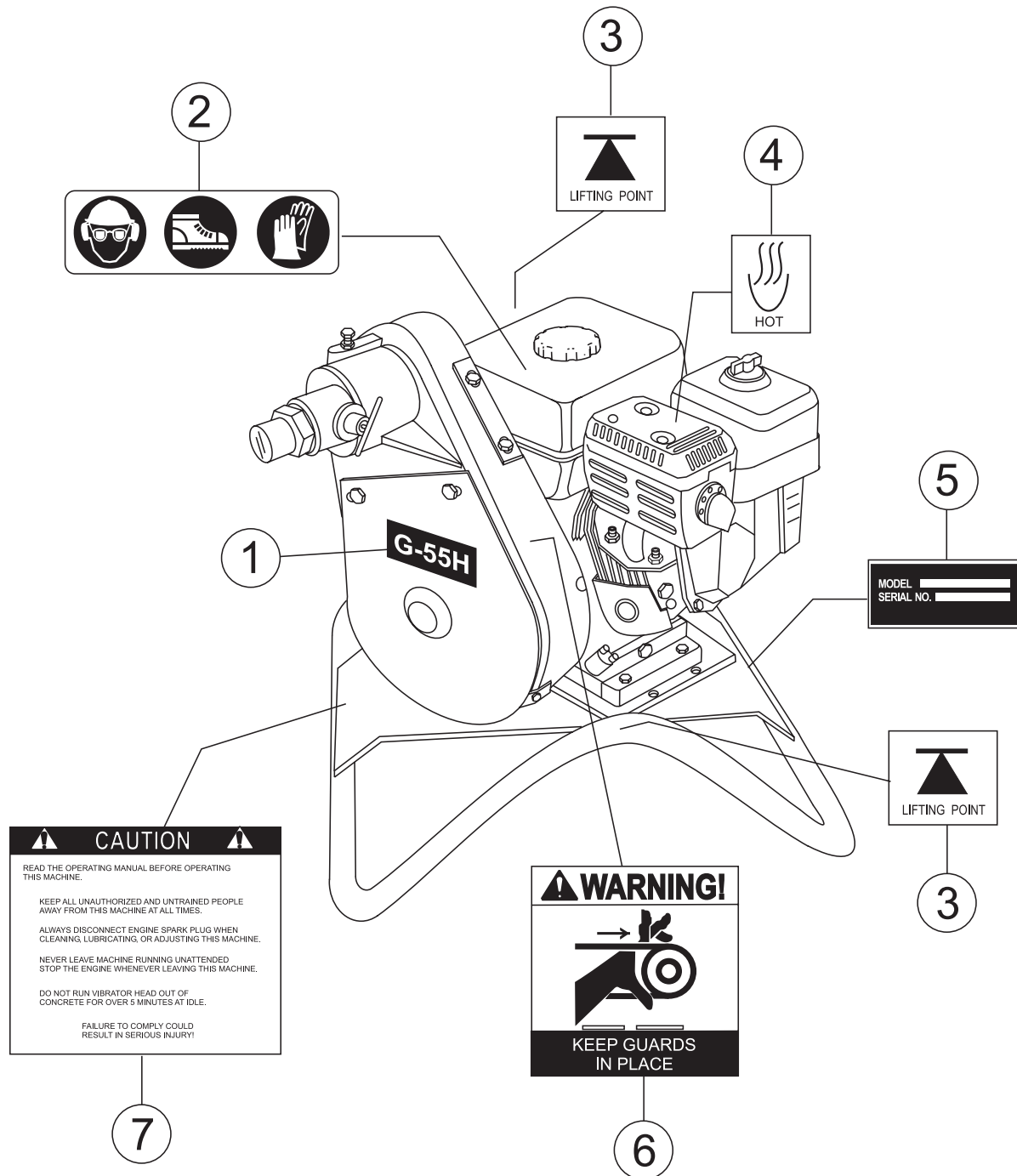

# G-55H GASOLINE VIBRATOR — NAMEPLATE AND DECALS

## NAMEPLATE AND DECALS.

<u>NO.</u>	<u>PART NO.</u>	<u>PART NAME</u>	
1	36521	DECAL, G-55H	1
2	11247	DECAL, HELMET, BOOT, GLOVES (ISO BLACK)	1
3	11246	DECAL, LIFT POINT .....	2 ..... PART OF DECAL KIT 11246
4	11246	DECAL, HOT SURFACE .....	1 ..... PART OF DECAL KIT 11246
5		NAMEPLATE .....	1 ..... CONTACT MQ PARTS DEPT.
6	21665	DECAL, WARNING, KEEP GUARDS IN PLACE	2
7	25883-001	DECAL, CAUTION, READ MANUAL	1

# G-55H GASOLINE VIBRATOR — ECCENTRIC/BODY ASSY.

## ECCENTRIC/BODY ASSY.

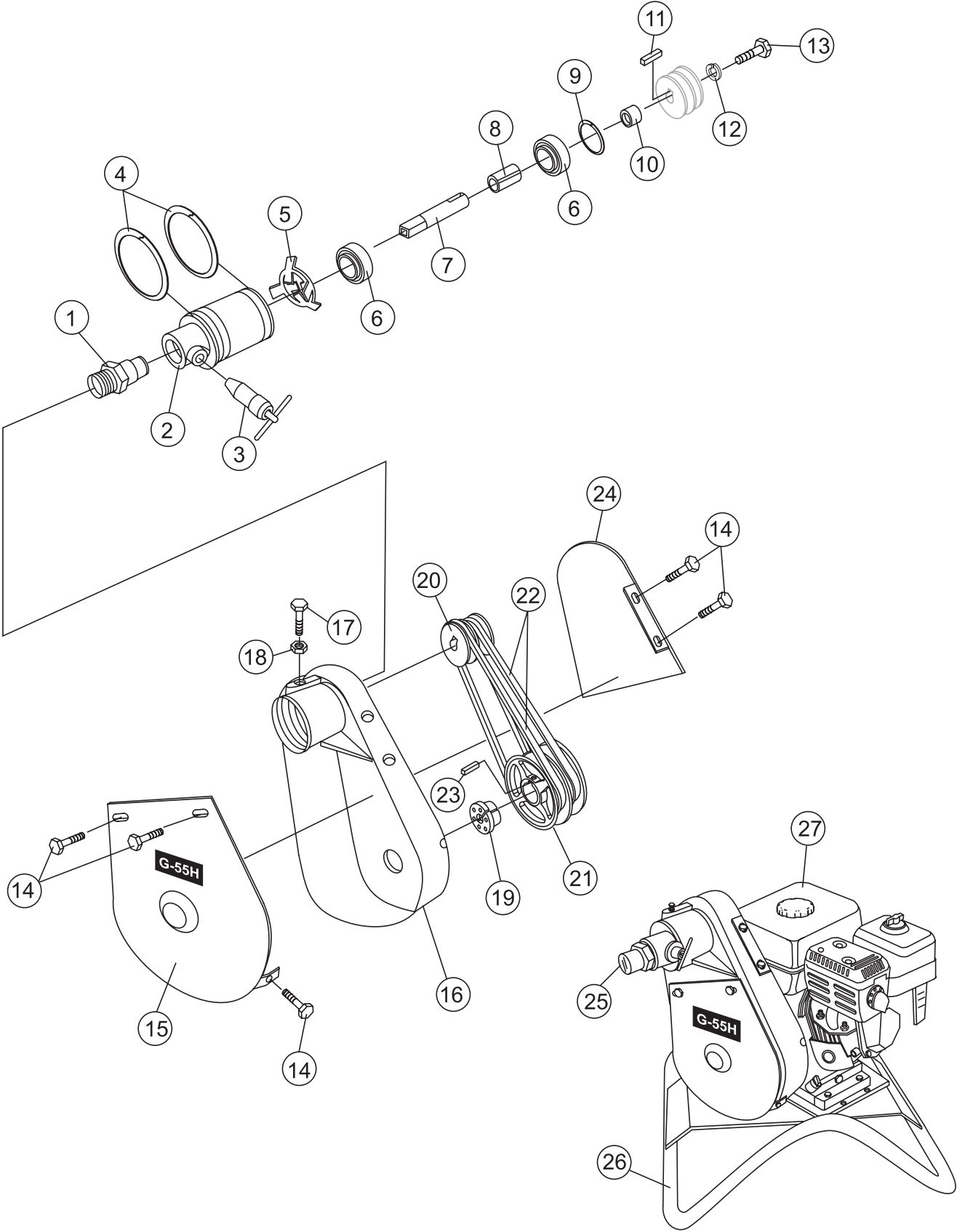

## G-55H GASOLINE VIBRATOR — ECCENTRIC/BODY ASSY.

### ECCENTRIC/BODY ASSY.

<u>NO</u>	<u>PART NO</u>	<u>PART NAME</u>	<u>QTY.</u>	<u>REMARK</u>
1	36248	COUPLING, SHAFT	1	
2	18045-501	ECCENTRIC ASSY. ....	1	INCLUDES ITEMS W/#
3#	25015-501	LOCK ASSEMBLY	1	
4#	08752-275	SNAP RING	2	
5#	06330-002	BEARING SPRING	1	
6#	14043-017	BEARING	2	
7#	14546-001	SPINDLE	1	
8#	08601-045	SPACER, SPLIT	1	
9#	08751-156	SNAP RING	1	
10#	06467-062	SPACER	1	
11#	584013	KEY 3/16" x 3/16" x 1"	1	
12#	2037	LOCKWASHER 5/16	1	
13#	20875	CAP SCREW 5/16" -18 x 3/4	1	
14	22538-001	SCREW - THREAD FORMING	8	
15	25845-001	BELT GUARD (FRONT)	1	
16	18024-001	HOUSING	1	
17	0202	SCREW, HHC 5/16"-18 x 1	1	
18	0106	NUT, HEX JAM 5/16"-18	1	
19	36517	QD BUSHING	1	
20#	18044-001	PULLEY (UPPER)	1	
21	36516	PULLEY (LOWER)	1	
22	16052	BELT 3VX335	2	
23	0627	KEY - 3/16 SQ. x 1-1/4	1	
24	25846-001	BELT GUARD (REAR)	1	
25#	11534-018	CAP, DUST	1	
26	27100-351	FRAME ASSEMBLY	1	
27	1386	ENGINE - 5.5 HP HONDA	1	

# G-55H GASOLINE VIBRATOR — PIVOT ASSY.

PIVOT ASSY.

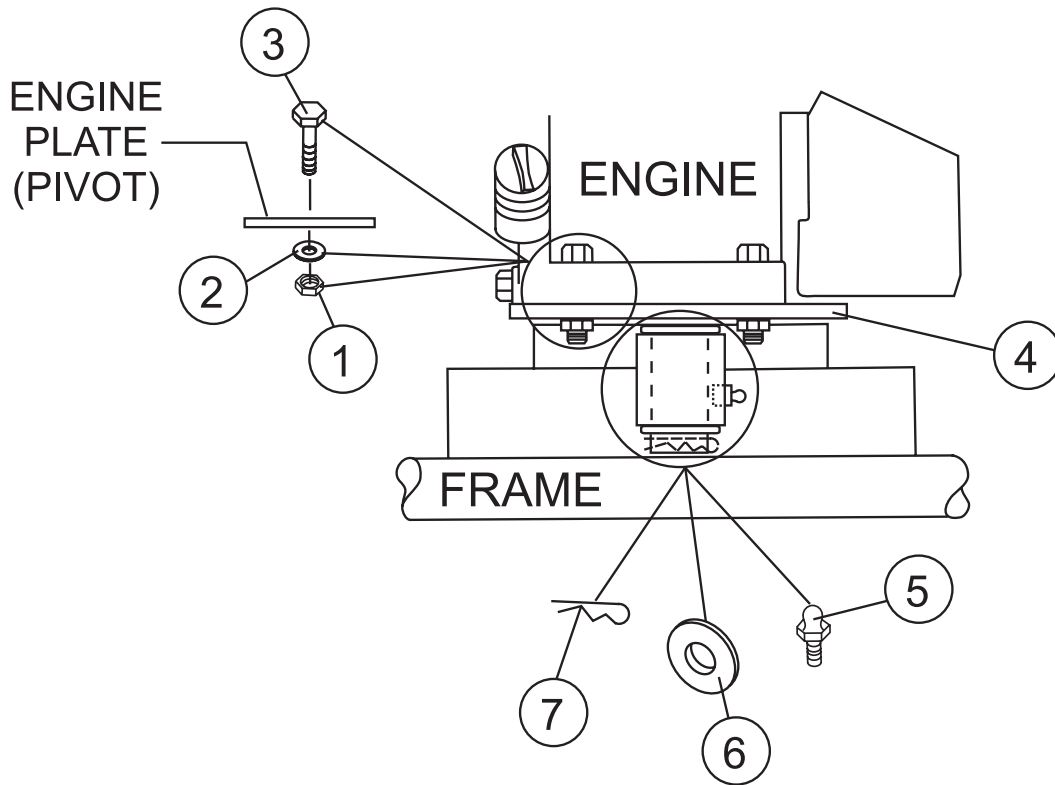

## G-55H GASOLINE VIBRATOR — PIVOT ASSY.

PIVOT ASSY.

<u>NO</u>	<u>PART NO</u>	<u>PART NAME</u>	<u>QTY.</u>	<u>REMARK</u>
1	5283	NUT - GRIPCO 5/16 - 18	4	
2	0300 B	FLATWASHER 5/16	4	
3	0105	HHCS 5/16 - 18 x 1 1/2	4	
4	27108-351	ENGINE PLATE - PIVOT	1	
5	2621	GREASE FITTING	1	
6	3264	FLATWASHER 1"	2	
7	07028-057	COTTER PIN 5/32" x 1-1/2	1	

# HONDA GX160K1QX2 ENGINE — AIR CLEANER ASSY.

AIR CLEANER ASSY.

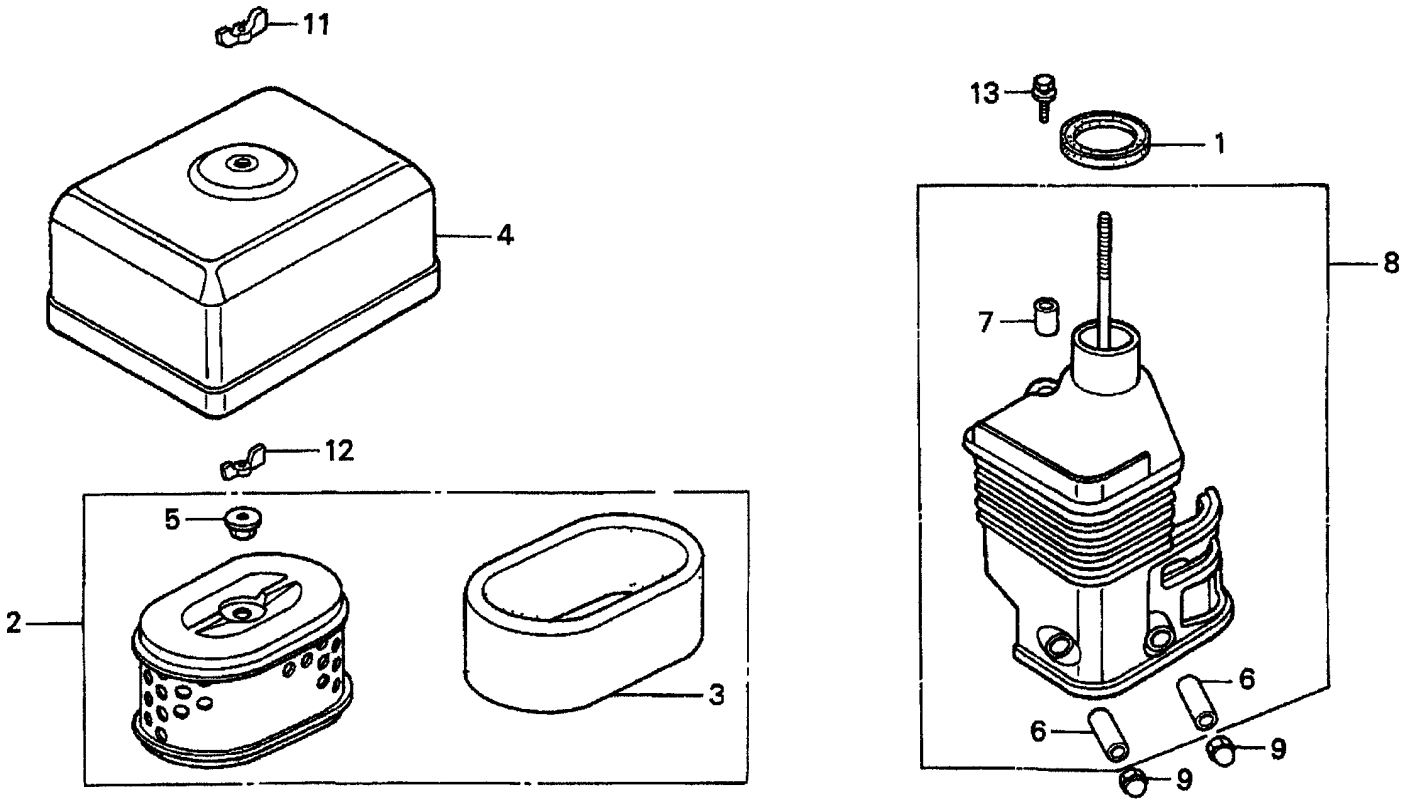

## HONDA GX160K1QX2 ENGINE — AIR CLEANER ASSY.

### AIR CLEANER ASSY.

<u>NO.</u>	<u>PART NO.</u>	<u>PART NAME</u>	<u>QTY.</u>	<u>REMARKS</u>
1	16271ZE1000	GASKET, ELBOW	1	
2	17210ZE1505	ELEMENT, AIR CLEANER (DUAL)	1	
3	17218ZE1821	FILTER, OUTER	1	
4	17230ZE1820	COVER, AIR CLEANER (DUAL)	1	
5	17232891000	GROMMET, AIR CLEANER	1	
6	17238ZE7010	COLLAR, AIR CLEANER	2	
7	17239ZE1000	COLLAR B, AIR CLEANER	1	
8	17410ZE1020	ELBOW, AIR CLEANER	1	
9	90201415000	NUT, CAP 6MM	2	
11	90325044000	WINGNUT, TOOL BOX SETTING	1	
12	90325044000	WINGNUT, TOOL BOX SETTING	1	
13	957010602000	BOLT, FLANGE 6 X 20	1	

# HONDA GX160K1QX2 ENGINE — CAMSHAFT ASSY.

CAMSHAFT ASSY.

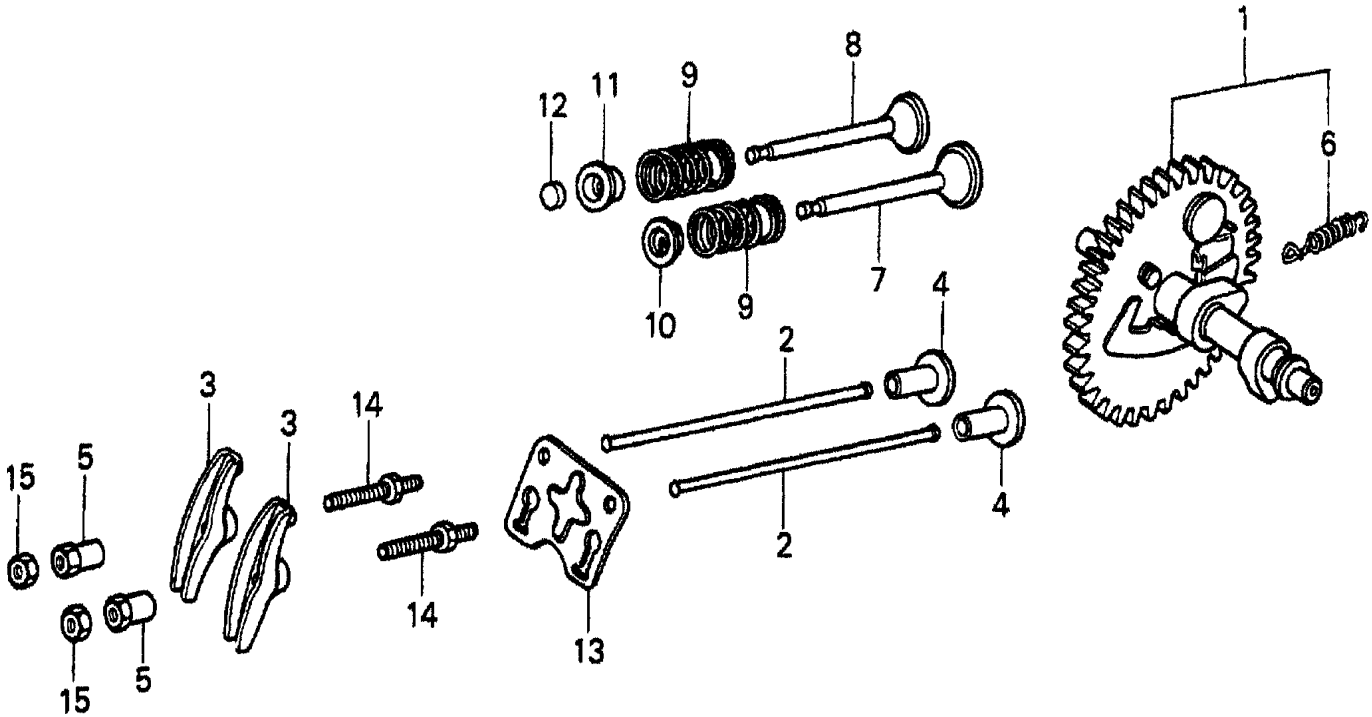

# HONDA GX160K1QX2 ENGINE — CAMSHAFT ASSY.

## CAMSHAFT ASSY.

<u>NO.</u>	<u>PART NO.</u>	<u>PART NAME</u>	<u>QTY.</u>	<u>REMARKS</u>
1	14100ZE1812	CAMSHAFT ASSEMBLY	1	
2	14410ZE1010	ROD, PUSH	2	
3	14431ZE1000	ARM, VALVE ROCKER	2	
4	14441ZE1010	LIFTER, VALVE	2	
5	14451ZE1013	PIVOT, ROCKER ARM	2	
6	14568ZE1000	SPRING, WEIGHT RETURN	1	
7	14711ZF1000	VALVE, INTAKE	1	
8	14721ZF1000	VALVE, EXHAUST	1	
9	14751ZF1000	SPRING VALVE	2	
10	14771ZE1000	RETAINER, INTAKE VALVE SPRING	1	
11	14773ZE1000	RETAINER, EXHAUST VALVE SPRING	1	
12	14781ZE1000	ROTATOR, VALVE	1	
13	14791ZE1010	PLATE, PUSH ROD GUIDE	1	
14	90012ZE0010	BOLT, PIVOT 8MM	2	
15	90206ZE1000	NUT, PIVOT ADJ.	2	

# HONDA GX160K1QX2 ENGINE — CARBURETOR ASSY.

CARBURETOR ASSY.

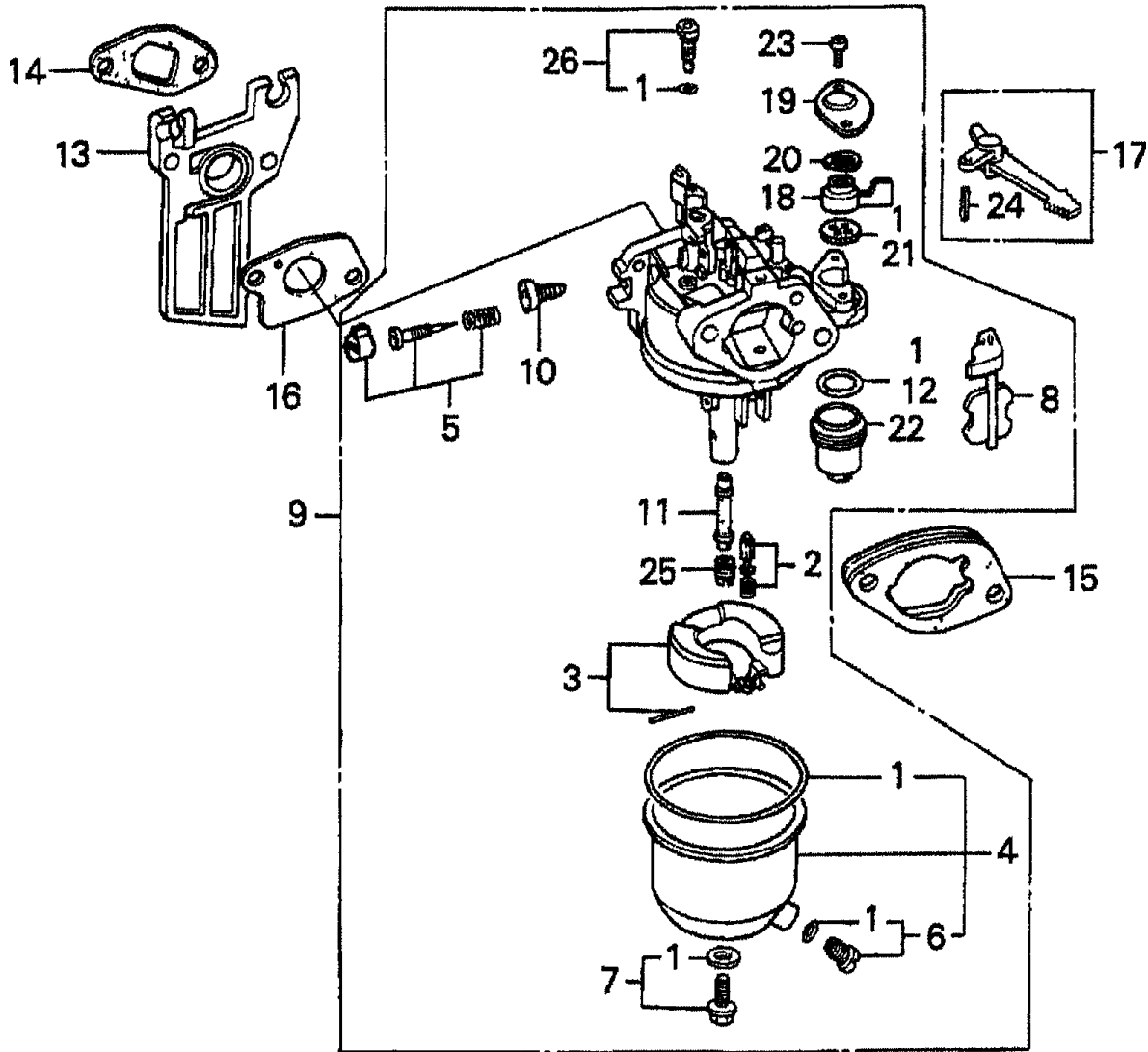

# HONDA GX160K1QX2 ENGINE — CARBURETOR ASSY.

## CARBURETOR ASSY.

<u>NO.</u>	<u>PART NO.</u>	<u>PART NAME</u>	<u>QTY.</u>	<u>REMARKS</u>
1*#+%	16010ZE1812	GASKET SET	1	
2*	16011ZE0005	VALVE SET, FLOAT	1	
3	16013ZE0005	FLOAT SET	1	
4*	16015ZE0831	CHAMBER SET, FLOAT .....	1	INCLUDES ITEMS/#
5*	16016ZH7W01	SCREW SET	1	
6*#	16024ZE1811	SCREW SET, DRAIN .....	1	INCLUDES ITEM W/+
7*	16028ZE0005	SCREW SET B .....	1	INCLUDES ITEM W/%
8*	16044ZE0005	CHOKE SET	1	
9	16100ZH8W51	CARBURETOR ASSEMBLY, BE65B B .....	1	INCLUDES ITEMS/*
10*	16124ZE0005	SCREW, THROTTLE STOP	1	
11*	16166ZH8W50	NOZZLE, MAIN	1	
12*	16173001004	O- RING	1	
13	16211ZE1000	INSULATOR, CARBURETOR	1	
14	16212ZH8800	GASKET, INSULATOR	1	
15	16220ZE1020	SPACER, CARBURETOR	1	
16	16221ZH8801	GASKET, CARBURETOR	1	
17	16610ZE1000	LEVER, CHOKE STANDARD .....	1	INCLUDES ITEM W/\$
18*	16953ZE1812	LEVER, VALVE	1	
19	16954ZE1812	PLATE, LEVER SETTING	1	
20*	16956ZE1811	SPRING, VALVE LEVER	1	
21*	16957ZE1812	GASKET, VALVE	1	
22*	16967ZE0811	CUP, FUEL STRAINER	1	
23*	93500030060H	SCREW, PAN 3 X 6	2	
24\$	9430520122	PIN, SPRING 2 X 12	1	
25*	99101ZH80650	JET, MAIN #65 (OPTIONAL)	1	
25*	99101ZH80680	JET, MAIN #68 (OPTIONAL)	1	
26*	99204ZE00350	JET SET, PILOT #35	1	

# HONDA GX160K1QX2 ENGINE — CONTROL ASSY.

CONTROL ASSY.

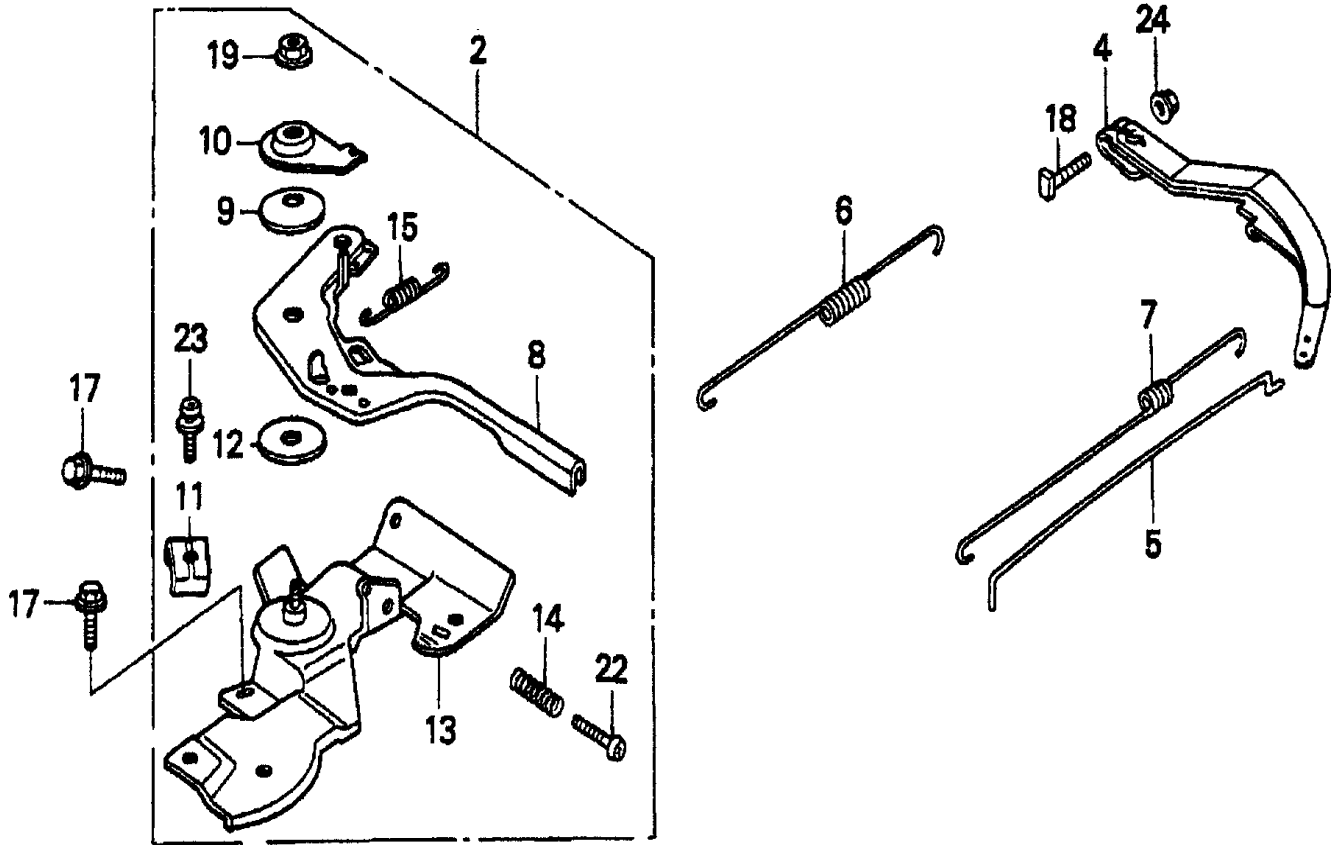

# HONDA GX160K1QX2 ENGINE — CONTROL ASSY.

## CONTROL ASSY.

<u>NO.</u>	<u>PART NO.</u>	<u>PART NAME</u>	<u>QTY.</u>	<u>REMARKS</u>
2	16500ZH8823	CONTROL ASSEMBLY, REMOTE .....	1 .....	INCLUDES ITEMS W/*
4	16551ZE0010	ARM, GOVERNOR	1	
5	16555ZE1000	ROD, GOVERNOR	1	
6	16561ZE1020	SPRING GOVERNOR	1	
7	16562ZE1020	SPRING, THROTTLE RETURN	1	
8*	16571ZH8020	LEVER, CONTROL	1	
9*	16574ZE1000	SPRING, LEVR	1	
10*	16575ZH8000	WASHER, CONTROL LEVER	1	
11*	16576891000	HOLDER, CABLE	1	
12*	16578ZE1000	SPACER, CONTROL LEVER	1	
13*	16580ZH8812	BASE, CONTROL (REMOTE)	1	
14*	16584883300	SPRING, CONTROL ADJUSTING	1	
15*	16592ZE1810	SPRING, CABLE RETURN	1	
17	90013883000	BOLT, FLANGE 6 X 12 (CT200)	2	
18	90016ZE5010	BOLT, GOVERNOR ARM	1	
19*	90114SA0000	NUT, SELF- LOCK 6MM	1	
22*	93500050250H	SCREW, PAN 5 X 25	1	
23*	938930501600	SCREW, WASHER 5 X 16	1	
24	9405006000	NUT, FLANGE 6MM	1	

# HONDA GX160K1QX2 ENGINE — CRANKCASE COVER ASSY.

CRANKCASE COVER ASSY.

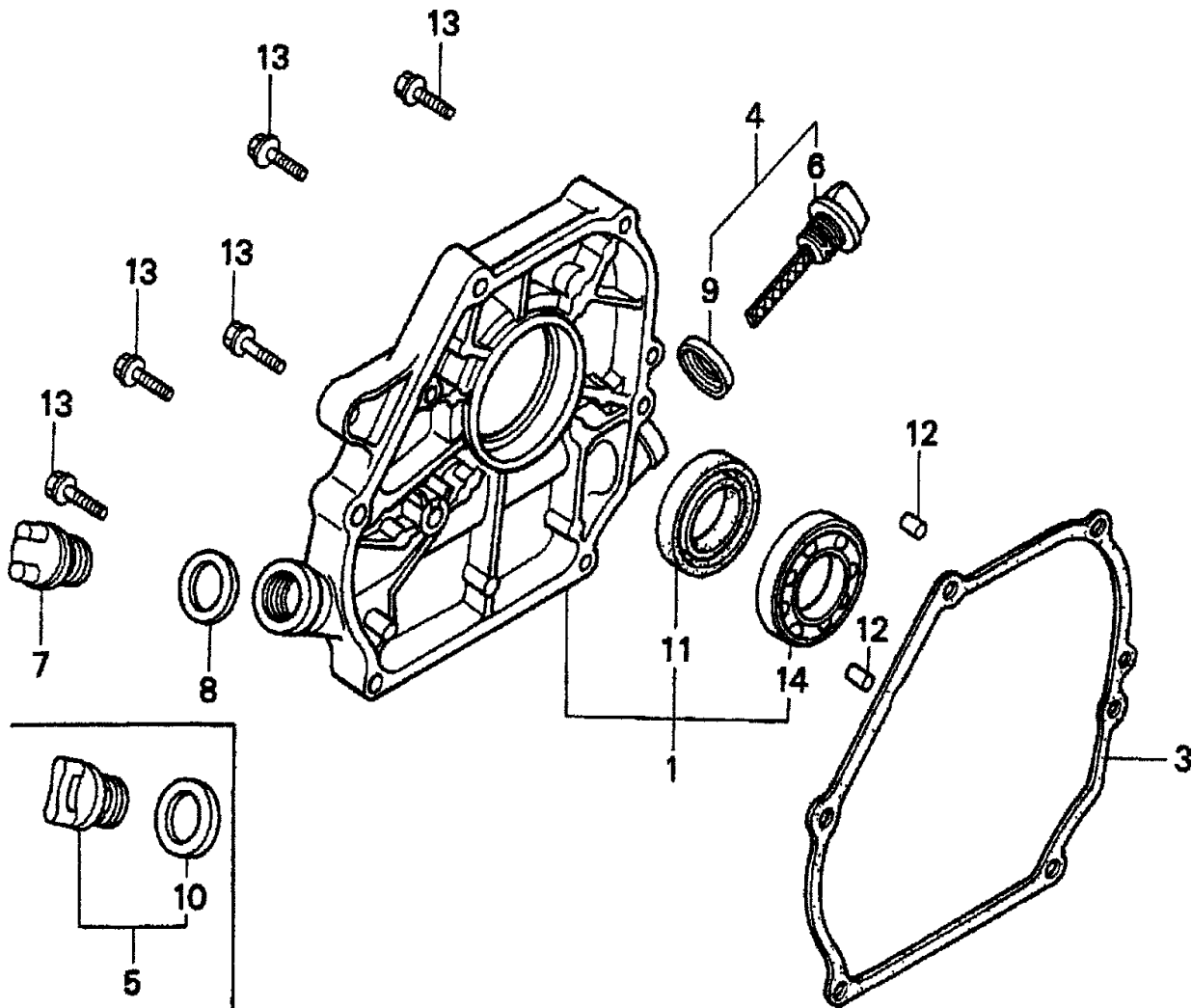

# HONDA GX160K1QX2 ENGINE — CRANKCASE COVER ASSY.

## CRANKCASE COVER ASSY.

<u>NO.</u>	<u>PART NO.</u>	<u>PART NAME</u>	<u>QTY.</u>	<u>REMARKS</u>
1	11300ZE1641	COVER ASSEMBLY, CRANKCASE (U- TYPE) .....	1 .....	INCLUDES ITEMS W/*
3	11381ZH8801	GASKET, CASE COVER (NON- ASBESTOS)	1	
4	15600ZE1003	CAP ASSEMBLY, OIL FILLER	1	
5	15600ZG4003	CAP ASSEMBLY, OIL FILLER	1	
9	15625ZE1003	GASKET, OIL FILLER CAP	1	
10	15625ZE1003	GASKET, OIL FILLER CAP	1	
11*	91202883005	OIL SEAL 25 X 41 X 6	1	
12	9430108140	PIN A, DOWEL 8 X 14	2	
13	957010803200	BOLT, FLANGE 8 X 32	6	
14*	961006205000	BEARING, RADIAL BALL 6205	1	

# HONDA GX160K1QX2 ENGINE — CRANKSHAFT/BALANCER ASSY.

CRANKSHAFT /BALANCER WEIGHT ASSY.

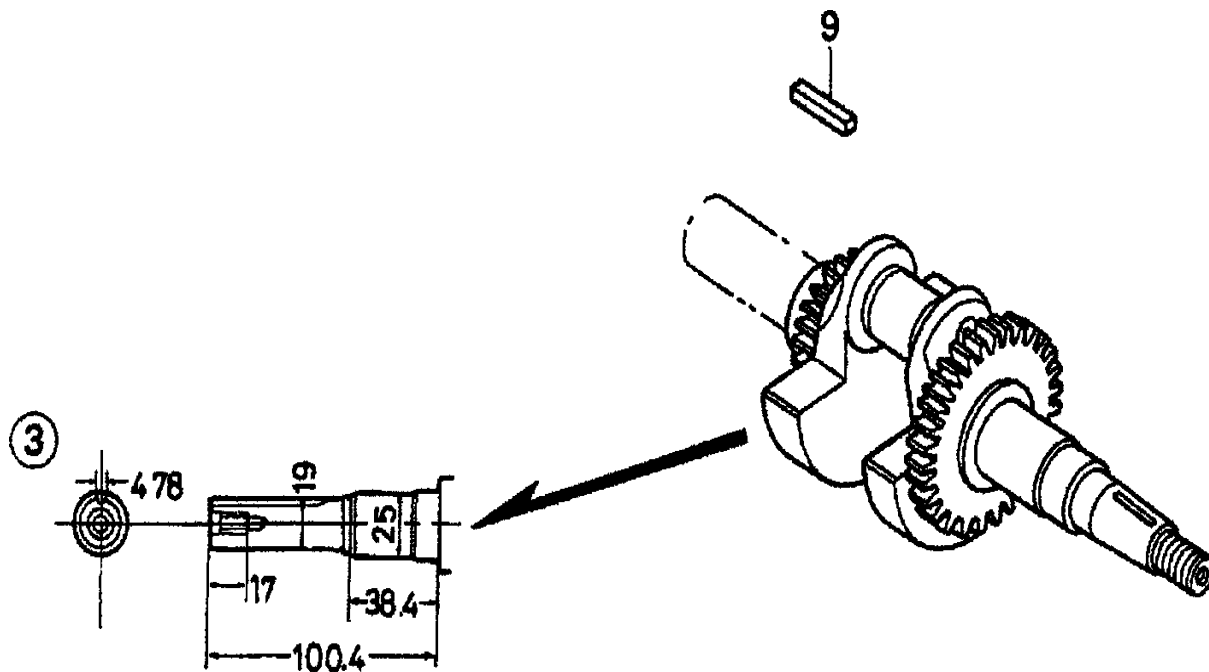

# HONDA GX160K1QX2 ENGINE — CRANKSHAFT/BALANCER ASSY.

CRANKSHAFT ASSY.

<u>NO.</u>	<u>PART NO.</u>	<u>PART NAME</u>	<u>QTY.</u>	<u>REMARKS</u>
3	13310ZE1601	CRANKSHAFT, Q- TYPE	1	
9	90745ZE1600	KEY, 4.78 X 4,78 X 38	1	

# HONDA GX160K1QX2 ENGINE — CYLINDER BARREL ASSY.

CYLINDER BARREL ASSY.

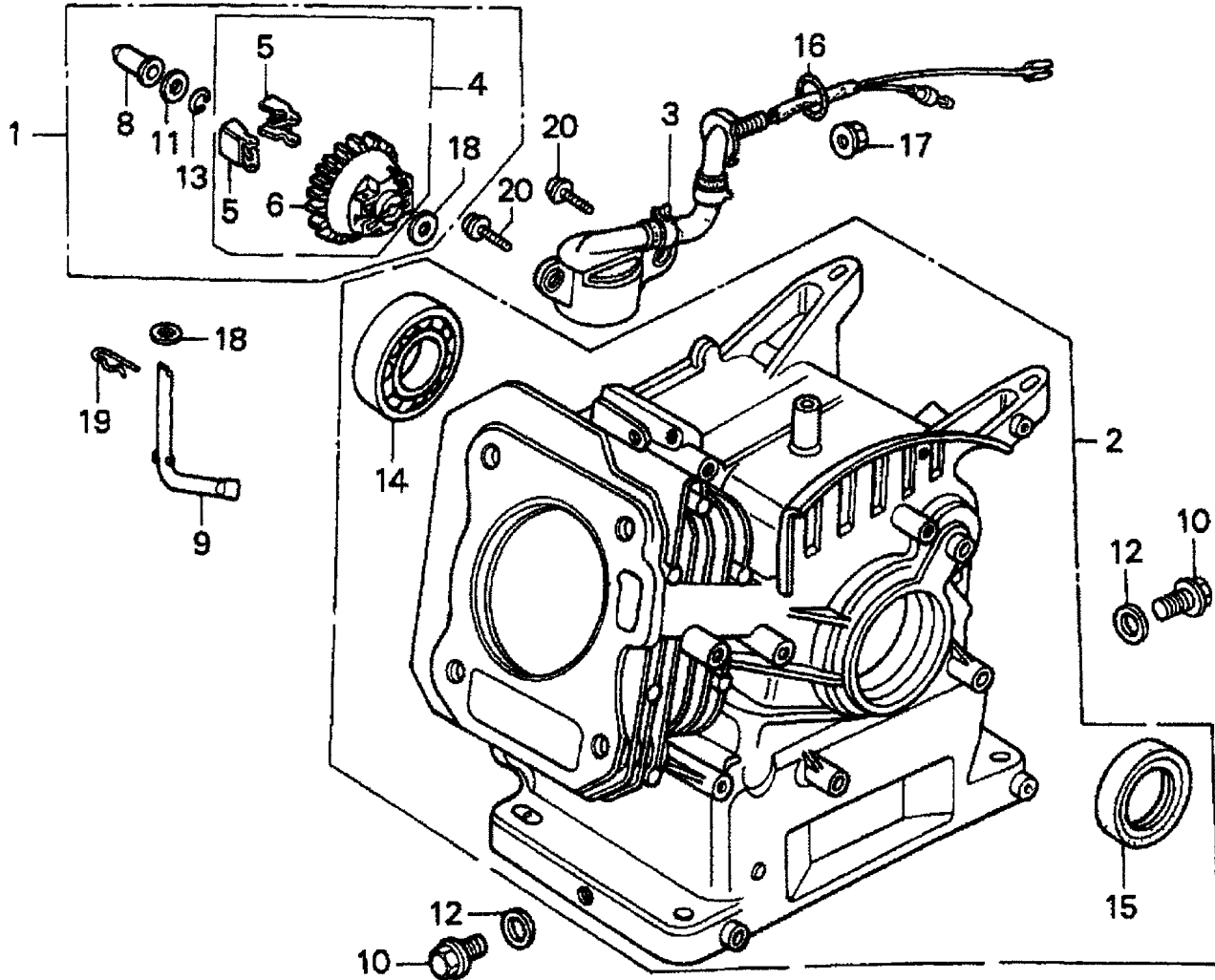

# HONDA GX160K1QX2 ENGINE — CYLINDER BARREL ASSY.

## CYLINDER BARREL ASSY.

<u>NO.</u>	<u>PART NO.</u>	<u>PART NAME</u>	<u>QTY.</u>	<u>REMARKS</u>
2	12000ZH8811	CYLINDER ASSEMBLY, OIL ALERT .....	1 .....	INCLUDES ITEMS W/*
3	15510ZE1033	SWITCH ASSEMBLY, OIL LEVEL .....	1 .....	INCLUDES ITEMS W/%
4*	16510ZE1000	GOVERNOR ASSEMBLY .....	1 .....	INCLUDES ITEMS W/#
5*#	16511ZE1000	WEIGHT, GOVERNOR	2	
6*#	16512ZE1000	HOLDER, GOVERNOR WEIGHT	1	
8*	16531ZE1000	SLIDER, GOVERNOR	1	
9	16541ZE1000	SHAFT, GOVERNOR ARM	1	
10	90131ZE1000	BOLT, DRAIN PLUG	2	
11*	80451ZE1000	WASHER, THRUST 6MM	1	
12	90601ZE1000	WASHER, DRAIN PLUG 10.2MM	2	
13*	90602ZE1000	CLIP, GOVERNOR HOLDER	1	
14%	91001ZF1003	BEARING, RADIAL BALL 6205	1	
15%	91202883005	OIL SEAL 25 X 41 X 6	1	
16	91353671003	O- RING 13.5 X 1.5 (ARAI)	1	
17	9405010000	NUT, FLANGE 10MM	1	
18*	9410106800	WASHER, PLAIN 6MM	2	
19	9425108000	PIN, LOCK 8MM	1	
20	957010601200	BOLT, FLANGE 6 X 12	2	

# HONDA GX160K1QX2 ENGINE — CYLINDER HEAD ASSY.

CYLINDER HEAD ASSY.

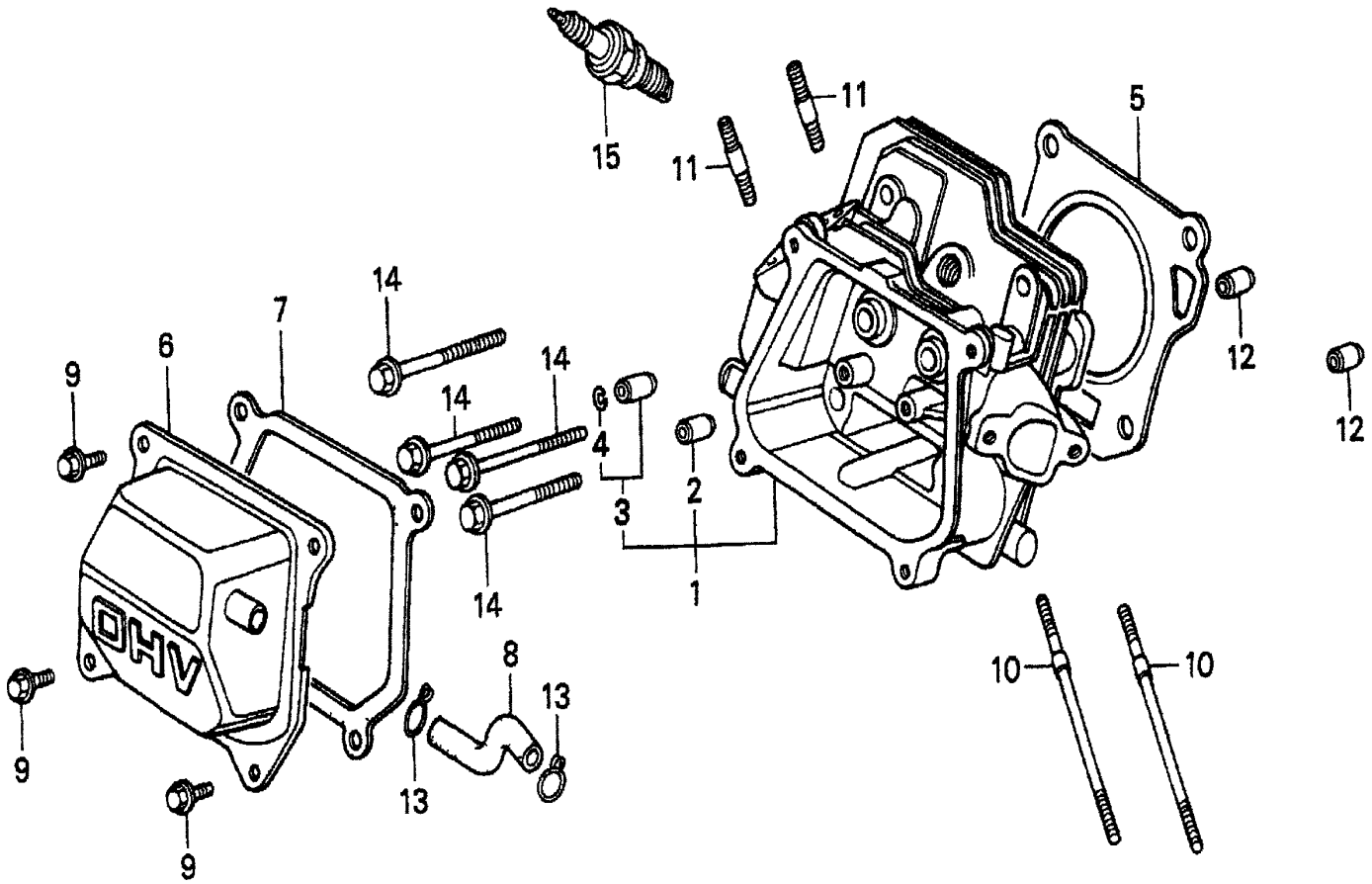

# HONDA GX160K1QX2 ENGINE — CYLINDER HEAD ASSY.

## CYLINDER HEAD ASSY.

<u>NO.</u>	<u>PART NO.</u>	<u>PART NAME</u>	<u>QTY.</u>	<u>REMARKS</u>
1	12210ZH8000	CYLINDER HEAD .....	1.....	INCLUDES ITEMS W/*
2*	12204ZE1306	GUIDE, VALVE OS (OPTIONAL	1	
3*	12205ZE1315	GUIDE, EXHAUST VALVE OS (OPTIONAL) .....	1.....	INCLUDES ITEM W/%
4%	12216ZE5300	CLIP, VALVE GUIDE	1	
5	12251ZF1800	GASKET, CYLINDER HEAD	1	
6	12310ZE1010	COVER, HEAD	1	
7	12391ZE1000	GASKET, CYLINDER HEAD COVER	1	
8	15721ZH8000	TUBE, BREATHER	1	
9	90016ZE1000	BOLT, FLANGE 6 X13	4	
10	90043ZE1020	BOLT, STUD 6 X109	2	
11	90047ZE1000	BOLT, STUD 8 X 32	2	
12	9430110160	PIN A, DOWEL 10 X16	2	
14	957230806000	BOLT, FLANGE 8 X60	4	
15	9807956846	SPARK PLUG BPR6ES (NGK)	1	

# HONDA GX160K1QX2 ENGINE — FAN COVER ASSY.

FAN COVER ASSY.

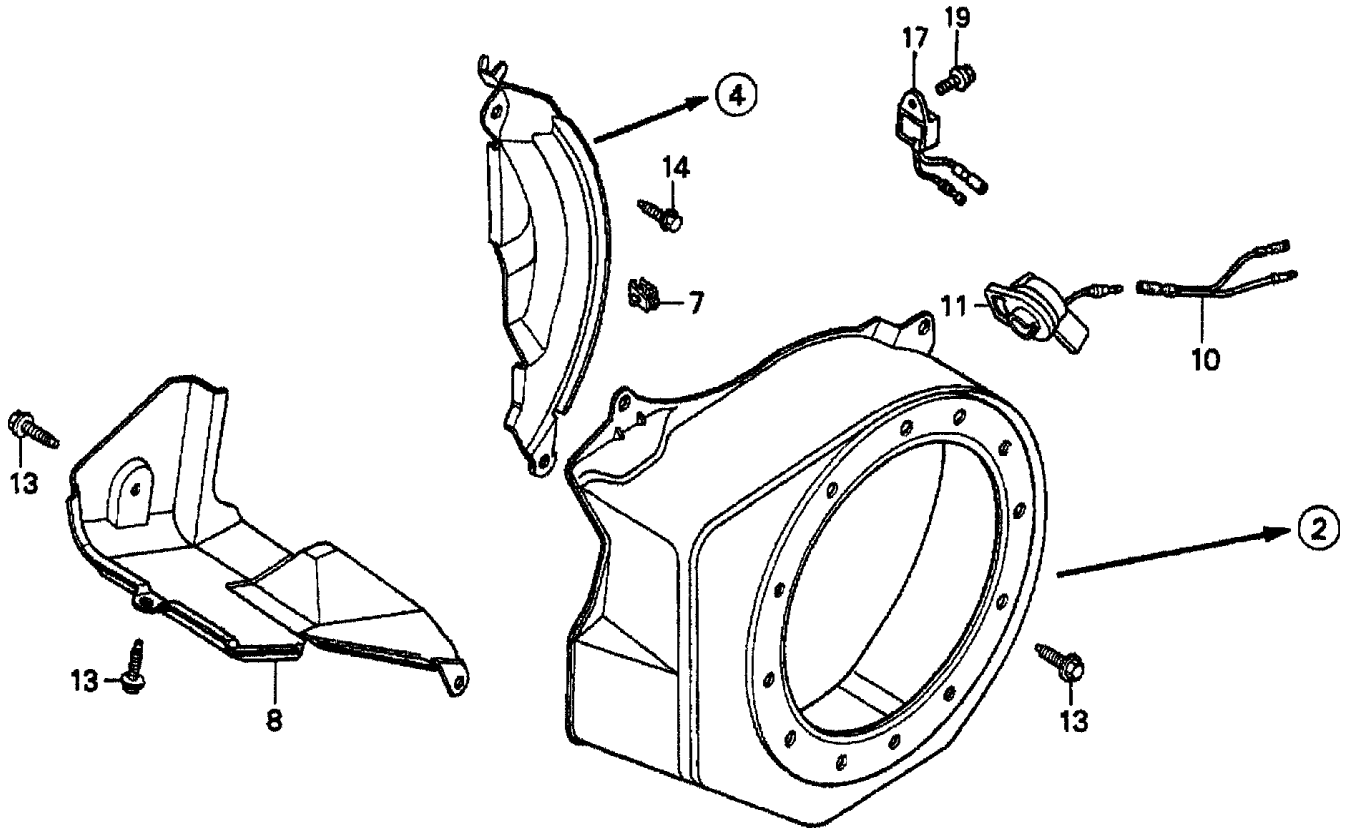

## HONDA GX160K1QX2 ENGINE — FAN COVER ASSY.

### FAN COVER ASSY.

<u>NO.</u>	<u>PART NO.</u>	<u>PART NAME</u>	<u>QTY.</u>	<u>REMARKS</u>
2	19610ZE1000ZC	COVER, FAN "NH1" (BLACK)	1	
4	19611ZH8810	PLATE, SIDE (OIL ALERT)	1	
7	90601ZH7013	CLIP, HARNESS	1	
8	19630ZH8000	SHROUD	1	
10	32197ZH8003	SUB- HARNESS	1	
11	36100ZE1015	SWITCH ASSEMBLY, ENGINE STOP	1	
13	90013883000	BOLT, FLANGE 6 X12 (CT200)	6	
14	90022888010	BOLT, FLANGE 6 X20 (CT200)	1	
17	34150ZH7003	ALERT UNIT, OIL	1	
19	957010600800	BOLT, FLANGE 6 X8	1	

# HONDA GX160K1QX2 ENGINE — FLYWHEEL ASSY.

FLYWHEEL ASSY.

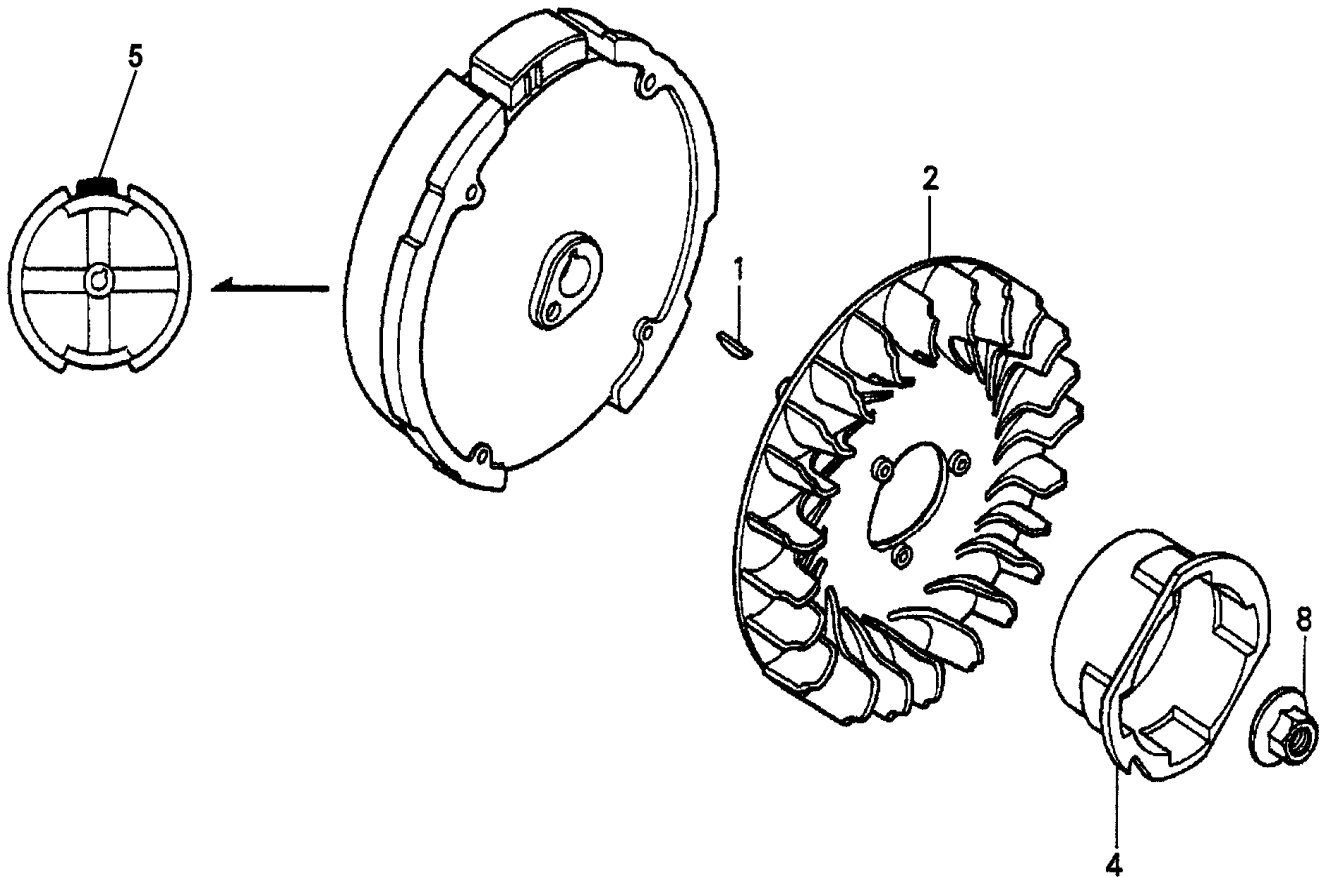

# HONDA GX160K1QX2 ENGINE — FLYWHEEL ASSY.

FLYWHEEL ASSY.

<u>NO.</u>	<u>PART NO.</u>	<u>PART NAME</u>	<u>QTY.</u>	<u>REMARKS</u>
1	13331357000	KEY, SPECIAL WOODRUFF (25 X18)	1	
2	19511ZE1000	FAN, COOLING	1	
4	28451ZH8003	PULLEY, STARTER	1	
5	31100ZE1010	FLYWHEEL	1	
5	31100ZE1810	FLYWHEEL, LAMP	1	
8	90201878003	NUT, SPECIAL 14MM	1	

# HONDA GX160K1QX2 ENGINE — FUEL TANK ASSY.

FUEL TANK ASSY.

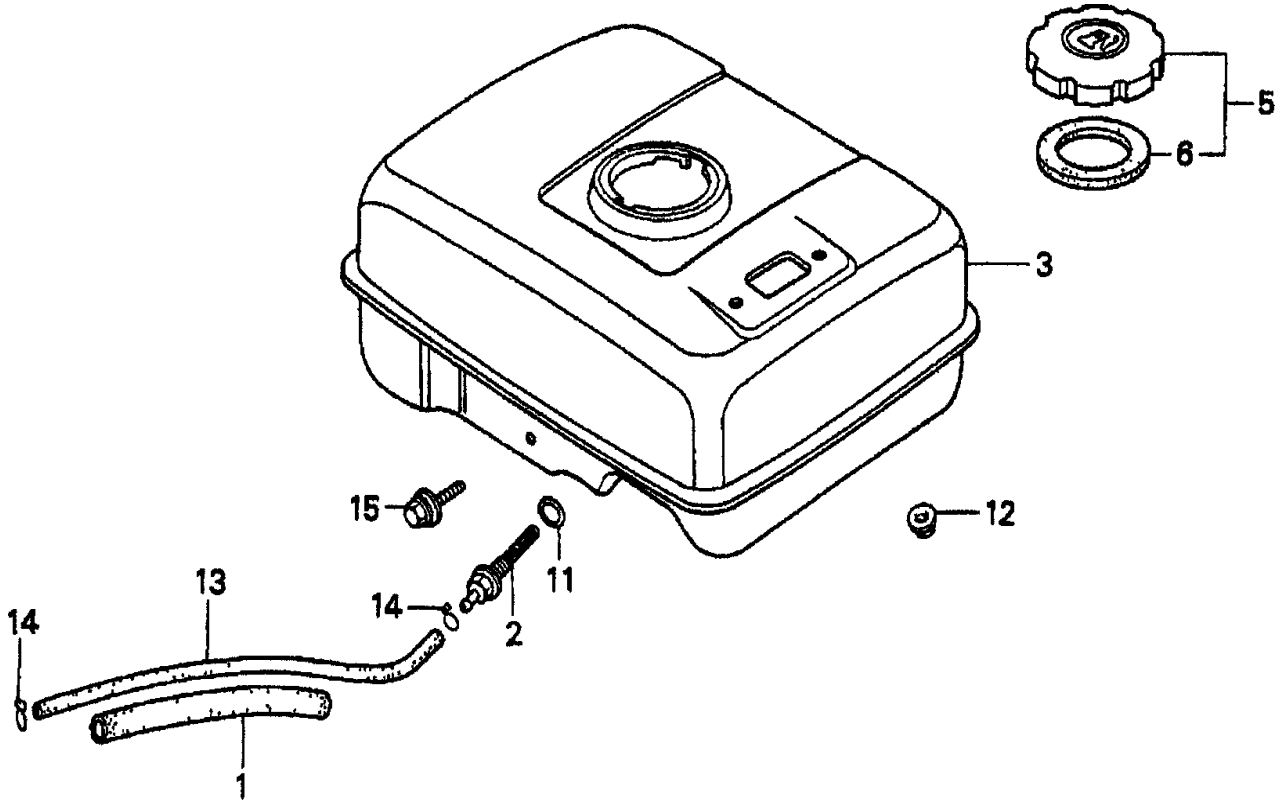

# HONDA GX160K1QX2 ENGINE — FUEL TANK ASSY.

## FUEL TANK ASSY.

<u>NO.</u>	<u>PART NO.</u>	<u>PART NAME</u>	<u>QTY.</u>	<u>REMARKS</u>
1	16854ZH8000	RUBBER, SUPPORTER 107MM	1	
2	16955ZE1000	JOINT, FUEL TANK	1	
3	17510ZE1020ZB	TANK, FUEL *R8* (BRIGHT RED)	1	
3	17510ZE1020ZF	TANK, FUEL *NH1* (BLACK)	1	
5	17620ZH7023	CAP, FUEL FILLER .....	1	INCLUDES ITEM W/*
6*	17631ZH7003	GASKET, FUEL FILLER CAP	1	
11	91353671003	O- RING 13.5 X1.5 (ARAI)	1	
12	9405006000	NUT, FLANGE 6MM	2	
13	950014500360M	BULK HOSE, FUEL 4.5 X 3000 (4.5 X 140)	1	
14	9500202080	CLIP, TUBE B8	2	
15	957010602500	BOLT, FLANGE 6 X 25	1	

# HONDA GX160K1QX2 ENGINE — IGNITION COIL ASSY.

IGNITION COIL ASSY.

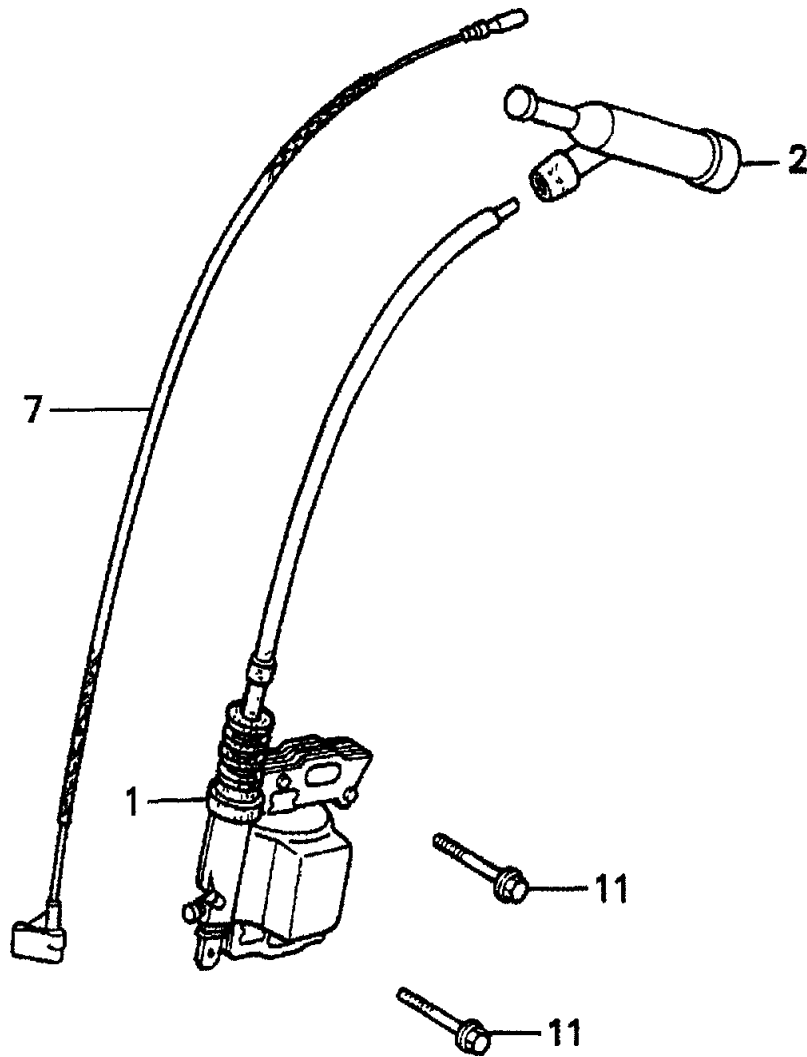

## HONDA GX160K1QX2 ENGINE — IGNITION COIL ASSY.

IGNITION COIL ASSY.

<u>NO.</u>	<u>PART NO.</u>	<u>PART NAME</u>	<u>QTY.</u>	<u>REMARKS</u>
1	30500ZE1033	COIL ASSEMBLY, IGNITION	1	
2	30700ZE1013	CAP ASSEMBLY, NOISE SUPPRESSOR	1	
7	36101ZE1010	WIRE, STOP SWITCH 370MM	1	
11	90121952000	BOLT, FLANGE 6 X25	2	

# HONDA GX160K1QX2 ENGINE — MUFFLER ASSY.

MUFFLER ASSY.

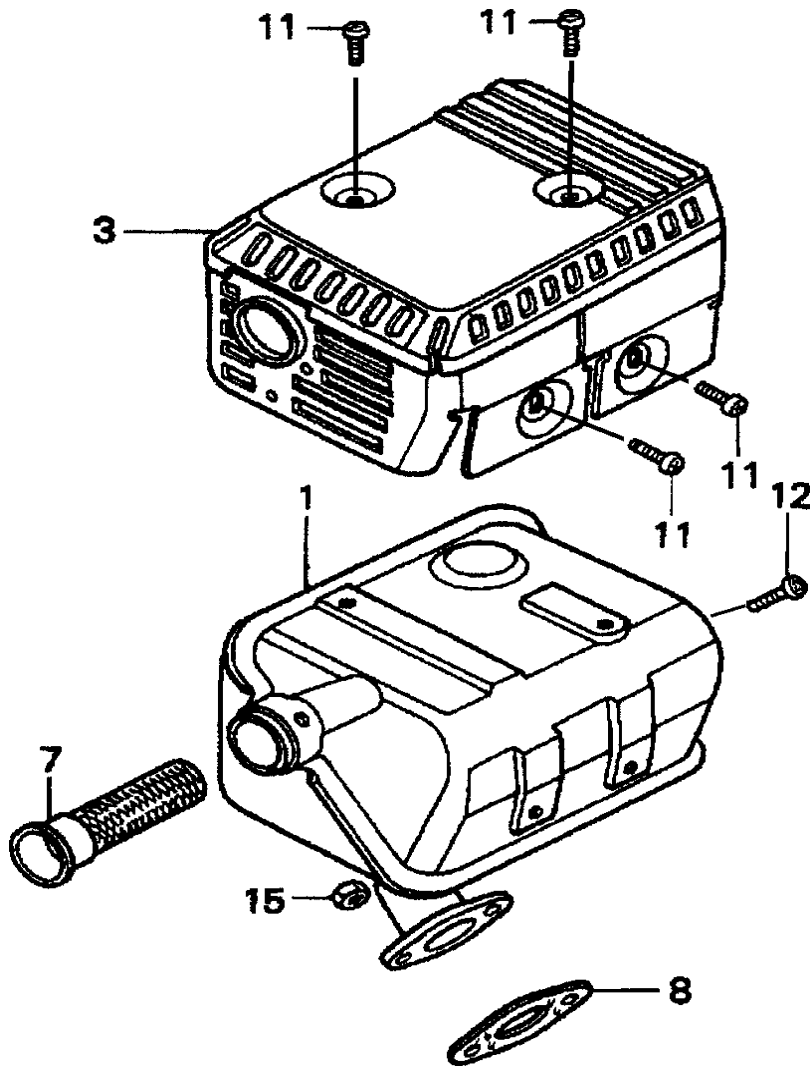

## HONDA GX160K1QX2 ENGINE — MUFFLER ASSY.

### MUFFLER ASSY.

<u>NO.</u>	<u>PART NO.</u>	<u>PART NAME</u>	<u>QTY.</u>	<u>REMARKS</u>
1	18310ZF1000	MUFFLER	1	
1	18310ZH8810	MUFFLER (OPTIONAL)	1	
3	18320ZF1H01	PROTECTOR, MUFFLER	1	
7	18355ZE1000	ARRESTER, SPARK (OPTIONAL)	1	
8	18381ZH8800	GASKET, MUFFLER	1	
11	90050ZE1000	SCREW, TAPPING 5 X 8 (OPTIONAL)	4	
12	90055ZE1000	SCREW, TAPPING 4 X 6 (OPTIONAL)	1	
15	94001080000S	NUT, HEX. 8MM	2	

# HONDA GX160K1QX2 ENGINE — PISTON ASSY.

PISTON ASSY.

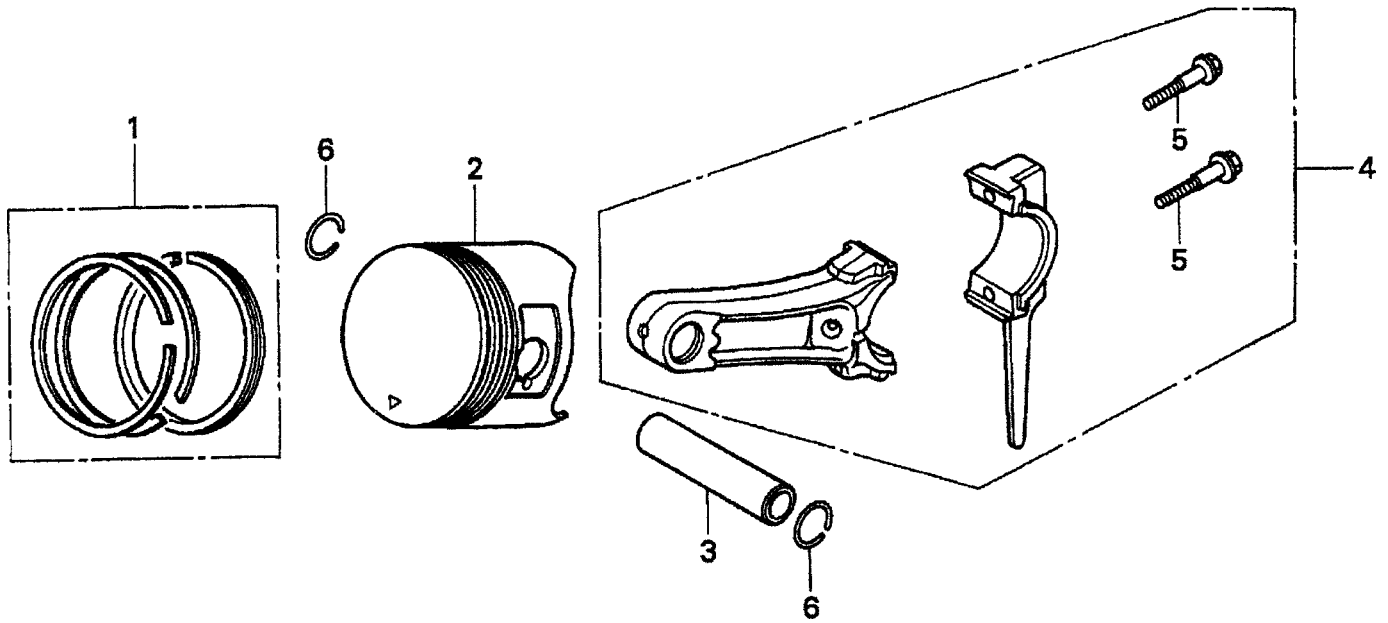

## HONDA GX160K1QX2 ENGINE — PISTON ASSY.

### PISTON ASSY.

<u>NO.</u>	<u>PART NO.</u>	<u>PART NAME</u>	<u>QTY.</u>	<u>REMARKS</u>
1	13010ZH8941	RING SET, PISTON (STANDARD)	1	
1	13011ZH8941	RING SET, PISTON (OS 0.25), OPTIONAL	1	
1	13012ZH8941	RING SET, PISTON (OS 0.50), OPTIONAL	1	
1	13013ZH8941	RING SET, PISTON (0.75), OPTIONAL	1	
2	13101ZH8000	PISTON (STANDARD)	1	
2	13102ZH8000	PISTON (OS 0.25), OPTIONAL	1	
2	13103ZH8000	PISTON (OS 0.50), OPTIONAL	1	
2	13104ZH8000	PISTON (0.75), OPTIONAL	1	
3	13111ZE1000	PIN, PISTON	1	
4	132AOZE1000	ROD ASSY., CONNECTING (US 0.25), OPT.	1	
4	13200ZE1010	ROD ASSEMBLY, CONNECTING	1	
5	90001ZE1000	BOLT, CONNECTING ROD	2	
6	90551ZE1000	CLIP, PISTON PIN 18MM	2	

# HONDA GX160K1QX2 ENGINE — RECOIL STARTER ASSY.

RECOIL STARTER ASSY.

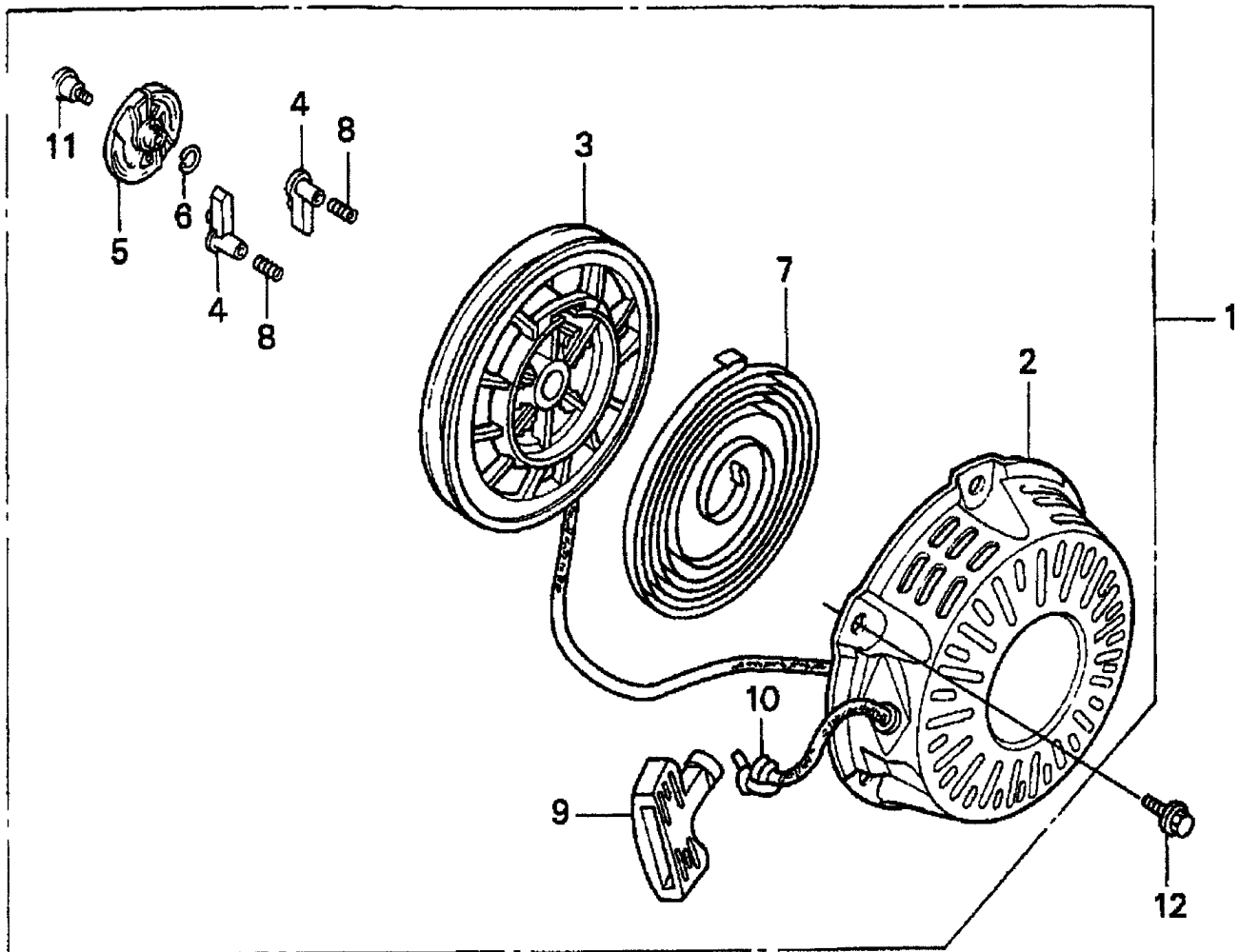

# HONDA GX160K1QX2 ENGINE — RECOIL STARTER ASSY.

## RECOIL STARTER ASSY.

<u>NO.</u>	<u>PART NO.</u>	<u>PART NAME</u>	<u>QTY.</u>	<u>REMARKS</u>
1	28400ZH8013ZB	STARTER ASSY., RECOIL "NH1" BLACK .....	1 .....	INCLUDES ITEM W/*
2*	28410ZH8003ZB	CASE, RECOIL STARTER "NH1" BLACK	1	
3*	28420ZH8013	REEL, RECOIL STARTER	1	
4*	28422ZH8013	RATCHET, STARTER	2	
5*	28433ZH8003	GUIDE, RATCHET	1	
6*	28441ZH8003	SPRING, FRICTION	1	
7*	28442ZH8003	SPRING, RECOIL STARTER	1	
8*	28443ZH8003	SPRING, RETURN	2	
9*	28461ZH8003	KNOB, RECOIL STARTER	1	
10*	28462ZH8003	ROPE, RECOIL STARTER	1	
11*	90003ZH8003	SCREW, SETTING	1	
12	90008ZE2003	BOLT, FLANGE 6 X10	3	

**NO ARTWORK AVAILABLE**

# HONDA GX160K1QX2 ENGINE — GASKET KIT ASSY.

## GASKET KIT ASSY.

<u>NO.</u>	<u>PART NO.</u>	<u>PART NAME</u>	<u>QTY.</u>	<u>REMARKS</u>
	06111ZH8405	GASKET KIT .....	1 .....	INCLUDES ITEMS W/*
1*	11381ZH8801	GASKET CASE COVER (NON- ASBESTOS)	1	
2*	12251ZF1800	GASKET, CYLINDER HEAD	1	
3*	12391ZE1000	GASKET, CYLINDER HEAD COVER	1	
4*	16212ZH8800	GASKET, INSULATOR	1	
5*	16221ZH8801	GASKET, CARBURETOR	1	
6*	18381ZH8800	GASKET, MUFFLER	1	

# HONDA GX160K1QX2 ENGINE — LABELS ASSY.

L ABELS ASSY.

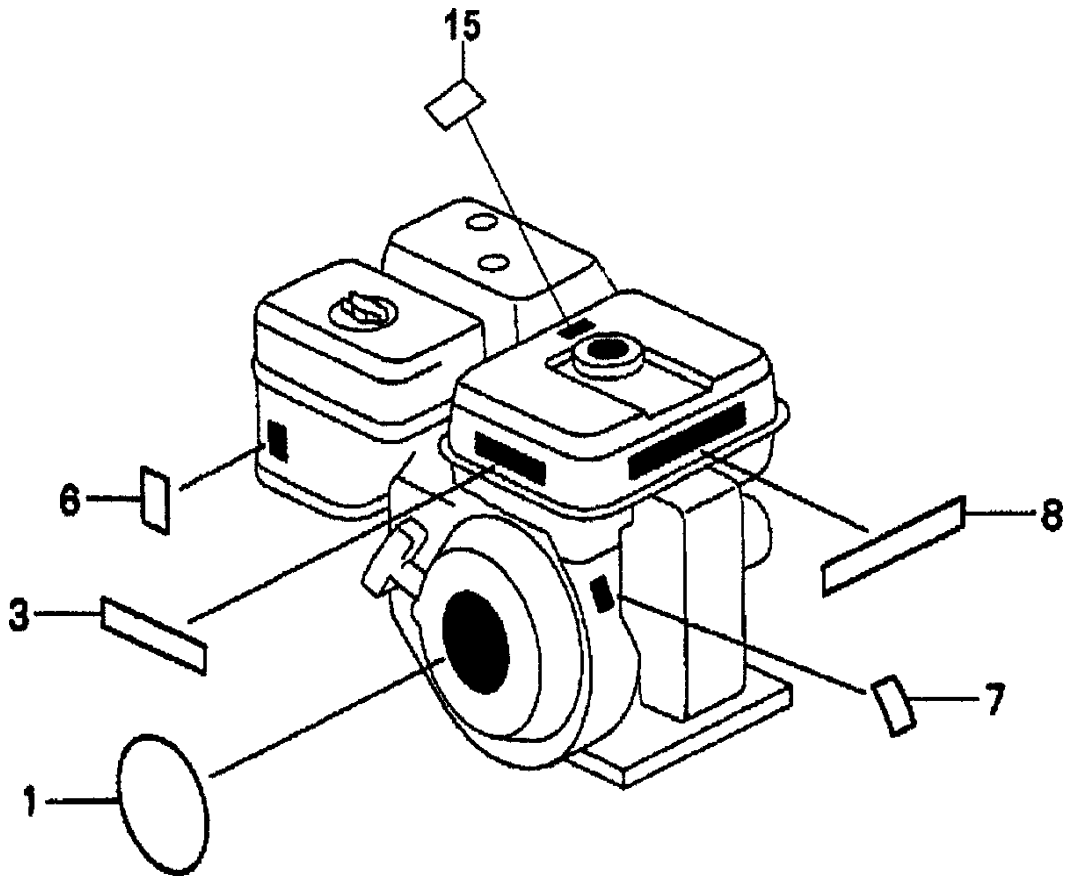

# HONDA GX160K1QX2 ENGINE — LABELS ASSY.

## ENGINE LABELS ASSY.

<u>NO.</u>	<u>PART NO.</u>	<u>PART NAME</u>	<u>QTY.</u>	<u>REMARKS</u>
1	87521ZH8020	ENBLEM 5.5	1	
2	87522ZE1810	MARK, CAUTION (EXTERNAL)	1	
3	87522ZH9000	LABEL, CAUTION	1	
6	87528ZE1810	MARK, CHOKE	1	
7	87530ZH8810	LABEL, SPECIFICATION (EXTERNAL)	1	
8	87532ZH8810	MARK, OIL ALERT (E)	1	
15	887586ZH7W00	LABEL, FUEL CAUTION	1	

**PAYMENT TERMS**

Terms of payment for parts are net 30 days.

**FREIGHT POLICY**

All parts orders will be shipped collect or prepaid with the charges added to the invoice. All shipments are F.O.B. point of origin. Multiquip's responsibility ceases when a signed manifest has been obtained from the carrier, and any claim for shortage or damage must be settled between the consignee and the carrier.

**MINIMUM ORDER**

The minimum charge for orders from Multiquip is \$15.00 net. Customers will be asked for instructions regarding handling of orders not meeting this requirement.

**RETURNED GOODS POLICY**

Return shipments will be accepted and credit will be allowed, subject to the following provisions:

1. A Returned Material Authorization must be approved by Multiquip prior to shipment.
2. To obtain a Return Material Authorization, a list must be provided to Multiquip Parts Sales that defines item numbers, quantities, and descriptions of the items to be returned.
  - a. The parts numbers and descriptions must match the current parts price list.
  - b. The list must be typed or computer generated.
  - c. The list must state the reason(s) for the return.
  - d. The list must reference the sales order(s) or invoice(s) under which the items were originally purchased.
  - e. The list must include the name and phone number of the person requesting the RMA.
3. A copy of the Return Material Authorization must accompany the return shipment.
4. Freight is at the sender's expense. All parts must be returned freight prepaid to Multiquip's designated receiving point.
5. Parts must be in new and resalable condition, in the original Multiquip package (if any), and with Multiquip part numbers clearly marked.
6. The following items are not returnable:
  - a. Obsolete parts. (If an item is in the price book and shows as being replaced by another item, it is obsolete.)
  - b. Any parts with a limited shelf life (such as gaskets, seals, "O" rings, and other rubber parts) that were purchased more than six months prior to the return date.
  - c. Any line item with an extended dealer net price of less than \$5.00.
  - d. Special order items.
  - e. Electrical components.
  - f. Paint, chemicals, and lubricants.
  - g. Decals and paper products.
  - h. Items purchased in kits.
7. The sender will be notified of any material received that is not acceptable.
8. Such material will be held for five working days from notification, pending instructions. If a reply is not received within five days, the material will be returned to the sender at his expense.
9. Credit on returned parts will be issued at dealer net price at time of the original purchase, less a 15% restocking charge.
10. In cases where an item is accepted, for which the original purchase document can not be determined, the price will be based on the list price that was effective twelve months prior to the RMA date.
11. Credit issued will be applied to future purchases only.

**PRICING AND REBATES**

Prices are subject to change without prior notice. Price changes are effective on a specific date and all orders received on or after that date will be billed at the revised price. Rebates for price declines and added charges for price increases will not be made for stock on hand at the time of any price change.

Multiquip reserves the right to quote and sell direct to Government agencies, and to Original Equipment Manufacturer accounts who use our products as integral parts of their own products.

**SPECIAL EXPEDITING SERVICE**

A \$35.00 surcharge will be added to the invoice for special handling including bus shipments, insured parcel post or in cases where Multiquip must personally deliver the parts to the carrier.

**LIMITATIONS OF SELLER'S LIABILITY**

Multiquip shall not be liable hereunder for damages in excess of the purchase price of the item with respect to which damages are claimed, and in no event shall Multiquip be liable for loss of profit or good will or for any other special, consequential or incidental damages.

**LIMITATION OF WARRANTIES**

No warranties, express or implied, are made in connection with the sale of parts or trade accessories nor as to any engine not manufactured by Multiquip. Such warranties made in connection with the sale of new, complete units are made exclusively by a statement of warranty packaged with such units, and Multiquip neither assumes nor authorizes any person to assume for it any other obligation or liability whatever in connection with the sale of its products. Apart from such written statement of warranty, there are no warranties, express, implied or statutory, which extend beyond the description of the products on the face hereof.



# OPERATION AND PARTS MANUAL

## HERE'S HOW TO GET HELP

PLEASE HAVE THE MODEL AND SERIAL  
NUMBER *ON-HAND* WHEN CALLING

### UNITED STATES

#### ***Multiquip Corporate Office***

18910 Wilmington Ave. Tel. (800) 421-1244  
Carson, CA 90746 Fax (800) 537-3927  
Contact: mq@multiquip.com

#### ***Mayco Parts***

800-306-2926 Fax: 800-672-7877  
310-537-3700 Fax: 310-637-3284

#### ***Service Department***

800-421-1244 Fax: 310-537-4259  
310-537-3700

#### ***MQ /STOWParts Department***

800-427-1244 Fax: 800-672-7877  
310-537-3700 Fax: 310-637-3284

#### ***Warranty Department***

800-421-1244, Ext. 279 Fax: 310-537-1173  
310-537-3700, Ext. 279

#### ***Technical Assistance***

800-478-1244 Fax: 310-631-5032

### MEXICO

#### ***MQ Cipsa***

Carr. Fed. Mexico-Puebla KM 126.5 Tel: (52) 222-225-9900  
Momoxpan, Cholula, Puebla 72760 Mexico Fax: (52) 222-285-0420  
Contact: pmastretta@cipsa.com.mx

### CANADA

#### ***Multiquip***

4110 Industriel Boul. Tel: (450) 625-2244  
Laval, Quebec, Canada H7L 6V3 Fax: (450) 625-8664  
Contact: jmartin@multiquip.com

### UNITED KINGDOM

#### ***Multiquip (UK) Limited Head Office***

Hanover Mill, Fitzroy Street, Tel: 0161 339 2223  
Ashton-under-Lyne, Fax: 0161 339 3226  
Lancashire OL7 0TL  
Contact: sales@multiquip.co.uk

### BRAZIL

#### ***Multiquip***

Av. Evandro Lins e Silva, 840 - grupo 505 Tel: 011-55-21-3433-9055  
Barra de Tijuca - Rio de Janeiro Fax: 011-55-21-3433-9055  
Contact: cnavarro@multiquip.com.br, srentes@multiquip.com.br

© COPYRIGHT 2006, MULTQUIP INC.

Multiquip Inc, the MQ logo and the STOW logo are registered trademarks of Multiquip Inc. and may not be used, reproduced, or altered without written permission. All other trademarks are the property of their respective owners and used with permission.

This manual MUST accompany the equipment at all times. This manual is considered a permanent part of the equipment and should remain with the unit if resold.

The information and specifications included in this publication were in effect at the time of approval for printing. Illustrations are based on the *MQ/STOW G-55H Gasoline Vibrator*. Illustrations, descriptions, references and technical data contained in this manual are for guidance only and may not be considered as binding. Multiquip Inc. reserves the right to discontinue or change specifications, design or the information published in this publication at any time without notice and without incurring any obligations.

Your Local Dealer is:

