

# OPERATION AND PARTS MANUAL

# STOW

A DIVISION OF MULTQUIP INC.

## PORTO-SCREED MODEL PSH

© COPYRIGHT 2004, MULTQUIP INC.

MODEL # \_\_\_\_\_

SERIAL # \_\_\_\_\_

Revision #1 (01/20/04)US

**STOW**  
A DIVISION OF MULTQUIP INC.

**STOW CONSTRUCTION EQUIPMENT**

*A DIVISION OF MULTQUIP INC.*

POST OFFICE BOX 6254

CARSON, CA 90749

310-537-3700 • 888-252-STOW [888-252-7869]

FAX: 310-537-1986 • FAX: 800-556-1986

E-MAIL: [stow@multiquip.com](mailto:stow@multiquip.com) • WWW: [stowmfg.com](http://stowmfg.com)

**PARTS DEPARTMENT:**

800-427-1244

FAX: 800-672-7877

**SERVICE DEPARTMENT/TECHNICAL ASSISTANCE:**

800-478-1244

FAX: 310-631-5032

**P/N 36442**



# WARNING



## **CALIFORNIA — Proposition 65 Warning**

Engine exhaust and some of its constituents, and some dust created by power sanding, sawing, grinding, drilling and other construction activities contains chemicals known to the State of California to cause cancer, birth defects and other reproductive harm. Some examples of these chemicals are:

- Lead from lead-based paints.
- Crystalline silica from bricks.
- Cement and other masonry products.
- Arsenic and chromium from chemically treated lumber.

Your risk from these exposures varies, depending on how often you do this type of work. To reduce your exposure to these chemicals: **ALWAYS** work in a well ventilated area, and work with approved safety equipment, such as dust masks that are specially designed to filter out microscopic particles.

## **HERE'S HOW TO GET HELP**

*PLEASE HAVE THE MODEL AND SERIAL  
NUMBER ON-HAND WHEN CALLING*

### ***PARTS DEPARTMENT***

*800-427-1244 or 310-537-3700*

*FAX: 800-672-7877 or 310-637-3284*

### ***SERVICE DEPARTMENT***

*800-421-1244*

*FAX: 310- 537-4259*

### ***TECHNICAL ASSISTANCE***

*800-478-1244*

*FAX: 310- 631-5032*

### ***WARRANTY DEPARTMENT***

*888-661-4279, or 310-661-4279*

*FAX: 310- 537-1173*

# PORTO-SCREED PSH—TABLE OF CONTENTS

## STOW — PORTO-SCREED PSH

Help and Technical Assistance .....	3
Table of Contents/Introduction .....	4
Parts Ordering Procedures U.K. & Europe .....	5
Parts Ordering Procedures U.S. ....	6
Specifications (PSH) .....	5
Specifications (Engine) .....	6
Safety Message Alert Symbols .....	7-8
Rules For Safe Operation .....	9-10
Operation And Safety Decals .....	11
Introduction/Intended Use .....	12
Assembly .....	13
Controls and Components .....	13
Basic Engine .....	14
Pre-Inspection .....	15
Initial Start-Up .....	16-17
Operation .....	18
Maintenance .....	19
Troubleshooting (Engine) .....	20
Suggested Spare Parts .....	21
Nameplate and Decals .....	22-23
Assembly .....	24-25
Terms and Conditions of Sale — Parts .....	26

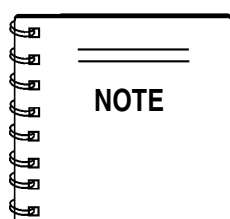

***Specifications and part numbers are subject to change without notice.***

# PORTO-SCREED PSH— SPECIFICATIONS (PSH)

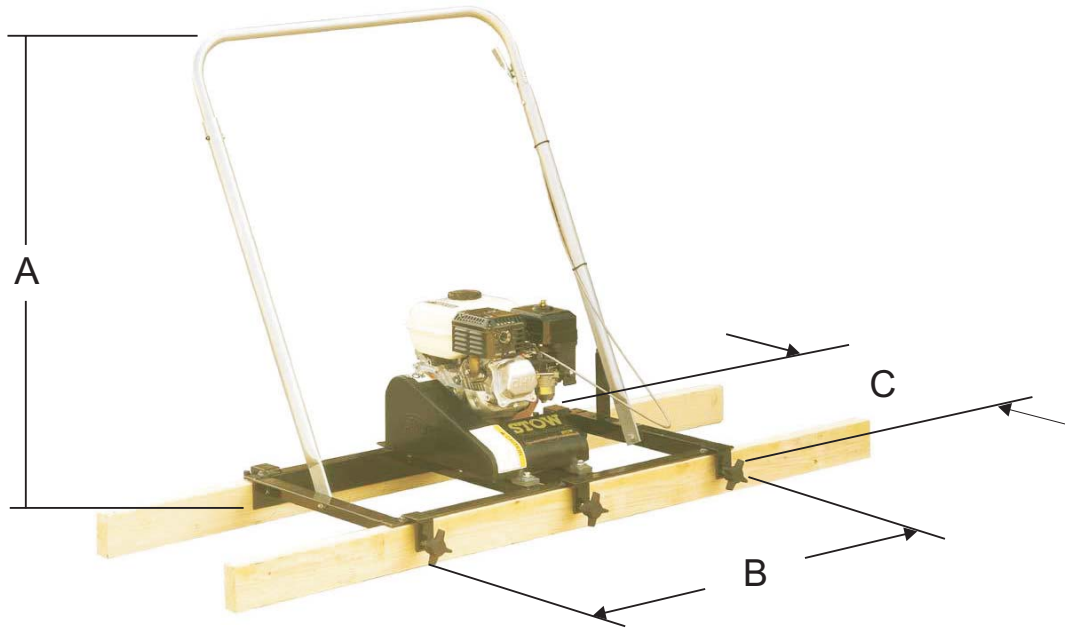

Figure 1. PORTO-SCREED PSH Dimensions

Table 1. PORTO-SCREED PSH Trowel Specifications

Height	28.0 in. ( 711 mm.)
Width (Less screeding beams)	24 in. (610 mm.)
Length	61 in. (1,550 mm.)
Hand/Arm Vibration	13.4 m/s <sup>2</sup>
Sound Pressure (A-Weighted)	94 db
Eccentric Speed	3000-4500 RPM
Engagement Speed	2400 RPM
Centrifugal Force	273 lbs. (1215 N) @ 3000 RPM 615 lbs. (2737 N) @ 4500 RPM
Maximum Screeding	16 Ft. (For One machine)
Path Width	24 in. (61 cm.)
Weight	90 lbs. (41 kg.)

**NOTE:**

1. Sound pressure is a weighted measure. It is measured at the operator's ear position while the walk-behind PSH is operating at full throttle on concrete in a manner most often experienced in "**normal**" circumstances. Sound pressure may vary depending upon the condition of the concrete. Hearing protection is always recommended.
2. The vibration level indicated is the maximum RMS (Root Mean Square) value obtained at the handle grip while operating the walk-behind PSH on dry sand in a manner most often experienced in "**normal**" circumstances. Values were obtained from all three axes of motion. The values shown represent the maximum RMS value from these measurements.

# PORTO-SCREED PSH— SPECIFICATIONS (ENGINE)

## Table 2. Engine Specifications

Engine	<b>Model</b>	<b>HONDA GX120K1QX2</b>
	Type	4-stroke, Overhead valve, Single Cylinder
	Bore X Stroke	2.4 in. X 1.7 in. (60 mm x 42 mm)
	Displacement	7.3 cu. in. (119 cc)
	Max Output	3.9 H.P. at 3,600 R.P.M.
	Fuel Tank Capacity	Approx. 0.66 U.S. Gallons (2.5 Liters)
	Standard Idle Speed	1,400 +200/-150 R.P.M.
	Fuel	Unleaded Gasoline
	Lube Oil Capacity	0..59 U.S. Quarts (0.56 Liters)
	Speed Control Method	Centrifugal Fly-weight Type
	Starting Method	Recoil Start
Dimension (L x W x H)	11.7 x 13.4 X 12.5 in. (297 X 341 X 318 mm)	
Dry Net Weight	28.7 lbs (13.0 Kg.)	

# PORTO-SCREED PSH— SAFETY MESSAGE ALERT SYMBOLS

## FOR YOUR SAFETY AND THE SAFETY OF OTHERS!

Safety precautions should be followed at all times when operating this equipment. Failure to read and understand the Safety Messages and Operating Instructions could result in injury to yourself and others.

### NOTE

This Owner's Manual has been developed to provide complete instructions for the safe and efficient operation of the STOW PORTO-SCREED. For engine maintenance information, please refer to the engine manufacturers instructions for data relative to its safe operation.

**Before using this Porto-Screed, ensure that the operating individual has read, understands, and complies with all instructions in this manual.**

## SAFETY MESSAGE ALERT SYMBOLS

The three (3) Safety Messages shown below will inform you about potential hazards that could injure you or others. The Safety Messages specifically address the level of exposure to the operator, and are preceded by one of three words: **DANGER**, **WARNING**, or **CAUTION**.

### **DANGER**

You **WILL** be **KILLED** or **SERIOUSLY INJURED** if you **DO NOT** follow these directions.

### **WARNING**

You **CAN** be **KILLED** or **SERIOUSLY INJURED** if you **DO NOT** follow these directions.

### **CAUTION**

You **CAN** be **INJURED** if you **DO NOT** follow these directions.

Potential hazards associated with PORTO-SCREED operation will be referenced with **Hazard Symbols** which appear throughout this manual, and will be referenced in conjunction with Safety **Message Alert Symbols**.

## HAZARD SYMBOLS



### Lethal Exhaust Gases



Engine exhaust gases contain poisonous carbon monoxide. This gas is colorless and odorless, and can cause death if inhaled. **NEVER** operate this equipment in a confined area or enclosed structure that does not provide ample free flow air.



### Explosive Fuel



Gasoline is extremely flammable, and its vapors can cause an explosion if ignited. **DO NOT** start the engine near spilled fuel or combustible fluids. **DO NOT** fill the fuel tank while the engine is running or hot. **DO NOT** overfill tank, since spilled fuel could ignite if it comes into contact with hot engine parts or sparks from the ignition system. Store fuel in approved containers, in well-ventilated areas and away from sparks and flames. **NEVER** use fuel as a cleaning agent.



### Burn Hazards



Engine components can generate extreme heat. To prevent burns, **DO NOT** touch these areas while the engine is running or immediately after operations. **NEVER** operate the engine with heat shields or heat guards removed.



### Rotating Parts



**NEVER** operate equipment with covers, or guards removed. Keep **fingers, hands, hair** and **clothing** away from all moving parts to prevent injury.

# PORTO-SCREED PSH— SAFETY MESSAGE ALERT SYMBOLS



## Respiratory Hazard

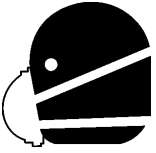

**ALWAYS** wear approved respiratory protection.



## Sight and Hearing hazard

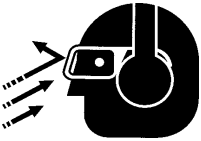

**ALWAYS** wear approved eye and hearing protection.



## Equipment Damage Messages

Other important messages are provided throughout this manual to help prevent damage to your PSH, other property, or the surrounding environment.

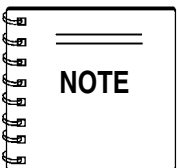

The "**NOTE**" symbol will be used whenever important or special information should be referenced.

# PORTO-SCREED PSH — RULES FOR SAFE OPERATION

## RULES FOR SAFE OPERATION

### CAUTION

Failure to follow instructions in this manual may lead to serious injury or even death! This equipment is to be operated by trained and qualified personnel only! This equipment is for industrial use only.

The following safety guidelines should always be used when operating the **PORTO-SCREED**.

### SAFETY

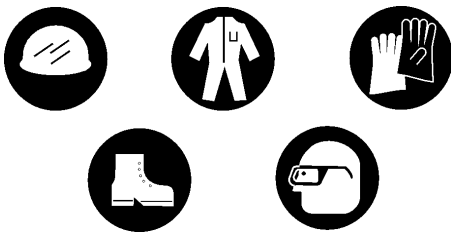

- **ALWAYS** read, understand, and follow procedures in Operator's Manual before attempting to operate or service this equipment. Make sure the operating instructions are available and accessible to the operator. 
- This equipment should not be operated by persons under the minimum statutory age limit.
- **NEVER** use this machine for any purpose other than those described in this manual.
- **NEVER** operate the PSH without proper protective clothing, shatterproof glasses, steel-toed boots and other protective devices required by the job.



- Manufacturer does not assume responsibility for any accident due to equipment modifications. Unauthorized equipment modification will void all warranties. Any modification which could lead to a change in the original characteristics of the machine should be made only by the manufacturer who shall confirm that the machine is in conformity with appropriate safety regulations.
- **ALWAYS** wear proper **respiratory** (mask), **hearing** and **eye** protection equipment when operating the PSH.

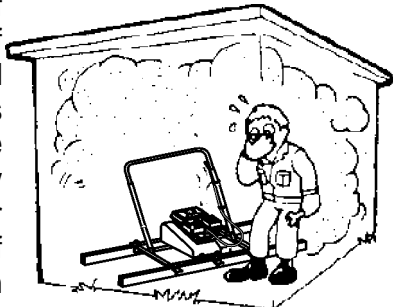

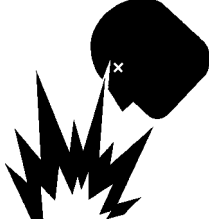
- **NEVER** operate this equipment when not feeling well due to fatigue, illness or taking medicine.
- **NEVER** operate the PSH under the influence of drugs or alcohol.
- **ALWAYS** check the PSH for loosened nuts or bolts before starting
- **NEVER** touch the hot exhaust manifold, muffler or cylinder. Allow these parts to cool before servicing the PSH. 
- **High Temperatures** – Allow the engine to cool before adding fuel or performing service and maintenance functions. Contact with **hot!** components can cause serious burns.
- The engine of this PSH requires an adequate free flow of cooling air. **NEVER** operate the PSH in any enclosed or narrow area where free flow of the air is restricted. If the air flow is restricted it will cause serious damage to the engine and may cause injury to people. Remember the engine gives off **DEADLY** carbon monoxide gas. 

- **ALWAYS** refuel in a well-ventilated area, away from sparks and open flames. 
- **NEVER** operate the PSH in an explosive atmosphere or near combustible materials. An explosion or fire could result causing severe **bodily harm or even death**.
- **ALWAYS** use extreme caution when working with **flammable** liquids. When refueling, **stop the engine** and allow it to cool.
- **NEVER** **smoke** around or near the machine. Fire or explosion could result from **fuel vapors**, or if fuel is spilled on a **hot!** engine. 
- Topping-off to filler port is dangerous, as it tends to spill fuel.
- **ALWAYS** close the fuel shut-off valve before refueling.
- **NEVER** use engine fuel as a cleaning agent.

# PORTO-SCREED PSH — RULES FOR SAFE OPERATION

- Whenever necessary, replace nameplate, operation and safety decals when they become difficult read.
- **NEVER** Run engine without air filter. Severe engine damage may occur. Service air filter frequently to prevent carburetor malfunction.
- **AVOID** wearing jewelry or loose fitting clothing that may snag on the controls or moving parts as this can cause a serious injury.
- **ALWAYS** keep clear of *rotating* or *moving parts* while operating the PSH.
- **Moving Parts** – Shut down the engine before performing service or maintenance functions. Contact with moving parts can cause serious injury.
- **ALWAYS** clear the work area around the screed of debris and obstructions to prevent tripping and/or falling onto the screed.
- **NEVER** leave the machine *unattended* while running, even for a brief moment. **DO NOT** leave the screed until it comes to a complete stop.
- **ALWAYS** store equipment properly when it is not being used. Equipment should be stored in a clean, dry location out of the reach of children.
- **ALWAYS** use factory authorized parts for replacement.
- Refer to the *HONDA Engine Owner's Manual* for engine technical questions or information recommended by the manufacturer for this equipment. Damage to the equipment and/or injury to user may result.
- No one other than the operator is to be in the working area when the porto-screed is in operation.
- Always observe all applicable compulsory regulations relevant to environmental protection, especially, fuel storage, the handling of hazardous substances, and the wearing of protective clothing and equipment. Instruct the user as necessary, or, as the user, request this information and training.

## Transporting

- **ALWAYS** shutdown engine before transporting.
- Tighten fuel tank cap securely and close fuel cock to prevent fuel from spilling.
- Drain fuel when transporting PSH over long distances or bad roads.
- When placing the PSH inside a truck-bed for transport, always tie-down the PSH.
- **ALWAYS** use proper lifting techniques when moving the PSH.

## Maintenance Safety

- **NEVER** lubricate components or attempt service on a running machine.
- **ALWAYS** allow the machine a proper amount of time to cool before servicing.
- Keep the machinery in proper running condition.
- Fix damage to the machine immediately and always replace broken parts.
- Dispose of hazardous waste properly. Examples of potentially hazardous waste are used motor oil, fuel and fuel filters.
- **DO NOT** use food or plastic containers to dispose of hazardous waste.

## Emergencies

- **ALWAYS** know the location of the nearest *fire extinguisher*.



- **ALWAYS** know the location of the nearest and *first aid kit*.



- In emergencies *always* know the location of the nearest phone or *keep a phone on the job site*. Also know the phone numbers of the nearest *ambulance, doctor* and *fire department*. This information will be invaluable in the case of an emergency.

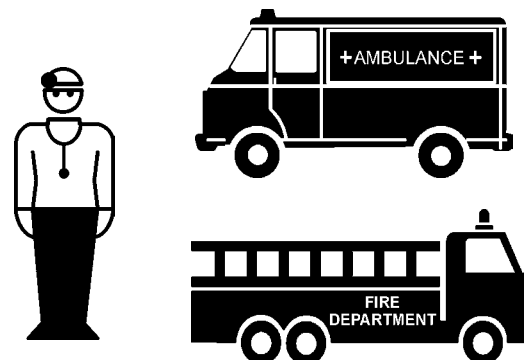
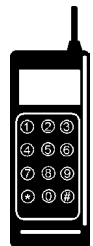

# PORTO-SCREED PSH— OPERATION AND SAFETY DECALS

## OPERATION AND SAFETY DECALS

The **PORTO-SCREED** walk-behind PSH is equipped with a number of operation and safety decals. These decals are provided for operator safety and maintenance information. Should any of these decals become unreadable, replacements can be obtained from your dealer.



P/N 20109-001



P/N 35137

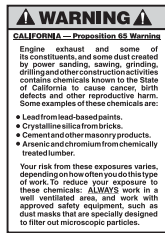
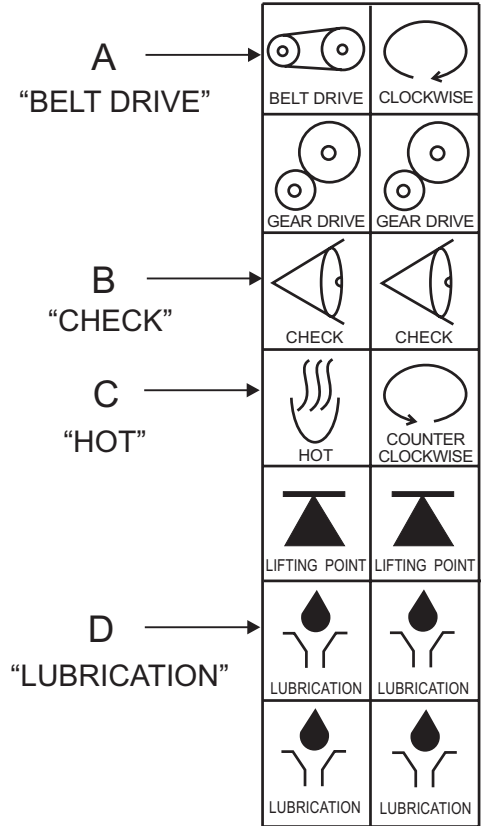

P/N 20525



P/N 21302



CONTACT SERVICE DEPARTMENT



P/N 13118



P/N 21571



P/N 36099 (ISO Blue)

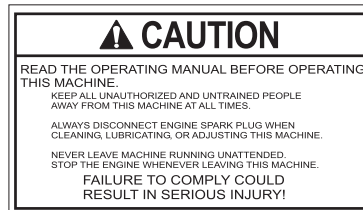

P/N 25263-001

DECAL SHEET  
INTL STDS ISO  
P/N 11246

Figure 2. PORTO-SCREED PSH Decals

## INTENDED USE

Operate the PSH Porto-Screed and components in accordance with the manufacturer's instructions. Any use other than for stated operation is considered contrary to designated use. The risk of such use lies entirely with the user. The manufacturer cannot be held liable for damages as a result of misuse.

## INTRODUCTION

The **STOW MODEL PSH PORTO-SCREED** is designed for vibration screeding concrete. Vibration screeding with the STOW Porto-screed is the ideal way to strike-off and vibrate concrete sidewalks, floors, patios, and even bridge decks.

The PSH Porto-Screed incorporates a variety of features that provide for ease of use. Among these are a throttle that allows selection of the appropriate vibration required for proper screeding, a free-swing handle, a handle-stop on the frame, a centrifugal clutch, recoil engine starter and a remote throttle control mounted on the handle within easy reach of the operator.



Figure 3. STOW Model PSH Porto-Screed

# PORTO-SCREED PSH— ASSEMBLY

## ASSEMBLY

### WARNING

Whenever assembling, lubricating or adjusting any part of the screed, make certain the engine is stopped with the spark plug wire disconnected and secured away from contact with the spark plug.

1. **Handle Assembly** – Gather all handle parts shown in the illustration below. Place them in front of the machine (side farthest from the engine). See Figure 4.

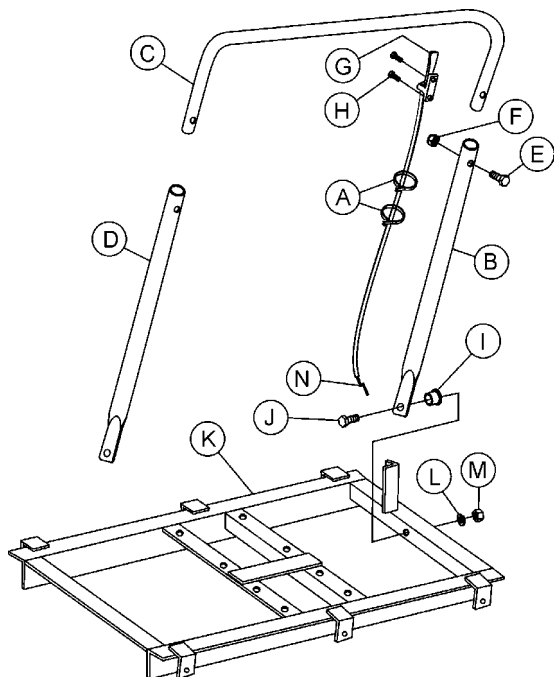

Figure 4. Handle Assembly

2. Slip throttle cable "O-ring" (A) over the right handle rod (B).
3. Slide the handle bar (C) over the handle rods. Ensure the side with the two holes are to the right.
4. Fasten the handle bar to the left handle rod (D) using bolt and nut (E and F). Fasten handle bar (with throttle control lever) to the right handle rod. Fasten the throttle control lever (G) to the handle bar with pan head screws (H).
5. Insert the flanged spacer (I) into the holes located in the flattened portions of the handle rods making sure the flanged end of both spacers are toward the outside.
6. Insert bolts (J) through the handle rods and the main frame (K). Install the lockwasher and nut (L and M) to both bolts.
7. Connect throttle wire (N) to the engine. Follow instructions in the engine manual for proper attachment.

## CONTROLS AND COMPONENTS

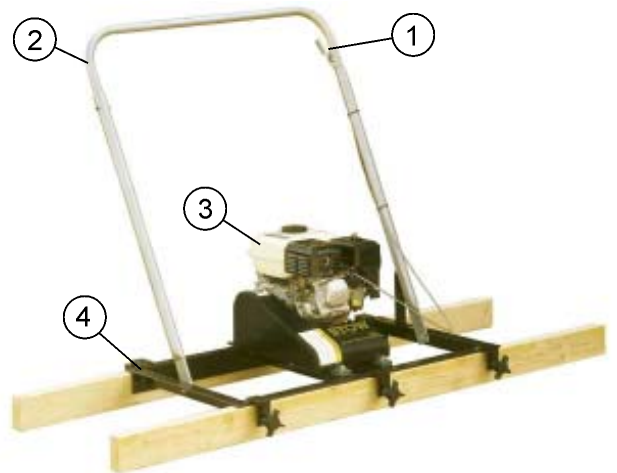

Figure 5. Controls and Components

Figure 5 shows the location of the basic controls or components, for the **PORTO-SCREED PSH**. Listed below is a brief explanation of each control or component

1. **Throttle Control Lever** – Controls the speed of the engine. Move the hand lever towards the operator to increase engine speed (high), away from the operator to decrease engine speed (low).
2. **Handle Bar** – When operating the PSH, place both hands on the bar to maneuver the PSH.
3. **Engine** – This PSH uses a Honda GX120 4 H.P. gasoline engine. See following sections on engine components and engine operation.
4. **Frame** – Supports engine and handle assemblies; allows clamping to screeding beams.

### CAUTION

**NEVER** attempt to *lift* the PSH by yourself. **ALWAYS** get the assistance of another person to help lift the PSH .

## Moving the PSH

This PSH is light weight, however for safety purposes always use **two people** to lift the PSH up onto a slab of concrete.

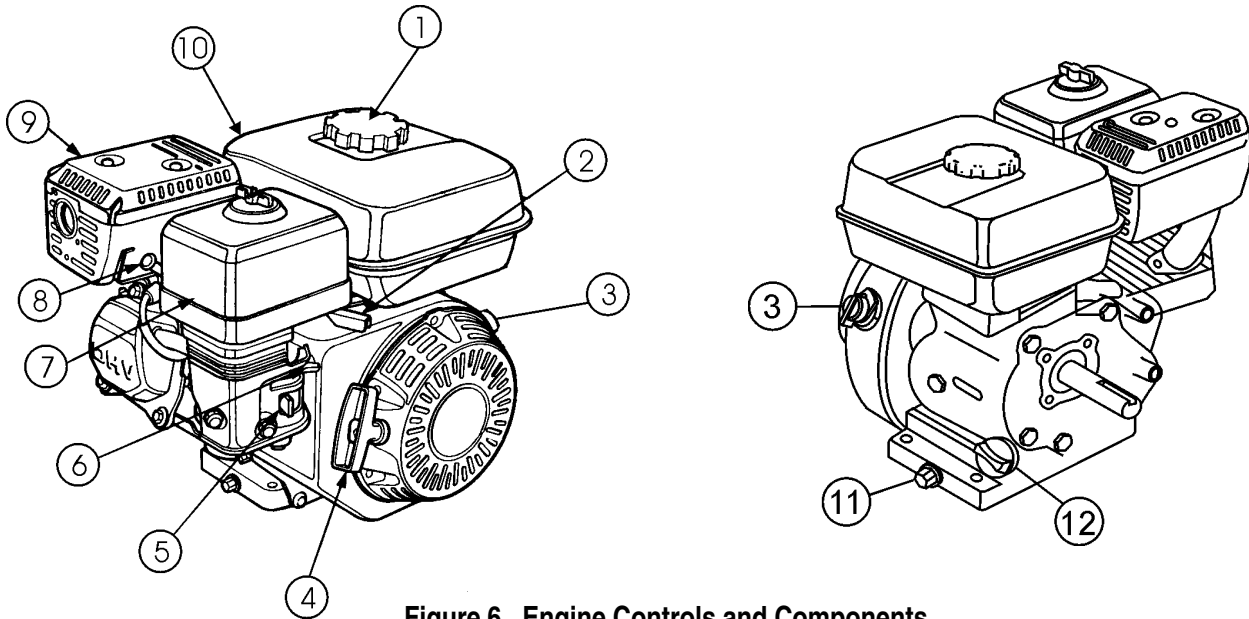

**Figure 6. Engine Controls and Components**

## INITIAL SERVICING

The engine (Figure 6) must be checked for proper lubrication and filled with fuel prior to operation. Refer to the manufacturer's engine manual for instructions & details of operation and servicing. The engine shown above is a **HONDA** engine, operation for other types of engines may vary somewhat.

- Fuel Filler Cap** – Remove this cap to add unleaded gasoline to the fuel tank. Make sure cap is tightened securely. **DO NOT** over fill.

**! DANGER**

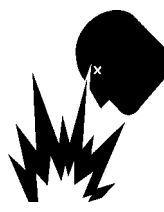

Adding fuel to the tank should be done only when the engine is stopped and has had an opportunity to cool down. In the event of a fuel spill, **DO NOT** attempt to start the engine until the fuel residue has been completely wiped up, and the area surrounding the engine is dry.

- Throttle Lever** – Used to adjust engine RPM speed (lever advanced forward **SLOW**, lever back toward operator **FAST**).
- Engine ON/OFF Switch** – **ON** position permits engine starting, **OFF** position stops engine operation.
- Recoil Starter (pull rope)** – Manual-starting method. Pull the starter grip until resistance is felt, then pull briskly and smoothly.
- Fuel Valve Lever** – **OPEN** to let fuel flow, **CLOSE** to stop the flow of fuel.

- Choke Lever** – Used in the starting of a cold engine, or in cold weather conditions. The choke enriches the fuel mixture.
- Air Cleaner** – Prevents dirt and other debris from entering the fuel system. Remove wing-nut on top of air filter canister to gain access to filter element.

**NOTE**



Operating the engine without an air filter, with a damaged air filter, or a filter in need of replacement will allow dirt to enter the engine, causing rapid engine wear.

- Spark Plug** – Provides spark to the ignition system. Clean spark plug once a week.
- Muffler** – Used to reduce noise and emissions.

**! WARNING**



Engine components can generate extreme heat. To prevent burns, **DO NOT** touch these areas while the engine is running or immediately after operating. **NEVER** operate the engine with the muffler removed.

- Fuel Tank** – Holds unleaded gasoline. For additional information refer to engine owner's manual.
- Oil Drain Plug** – Remove this plug to remove oil from the engine's crankcase.
- Dipstick/Oil Filler Cap** – Remove this cap to determine if the engine oil is low. Add oil through this filler port as recommended in Table 3.

# PORTO-SCREED PSH— PRE-INSPECTION

## PRE-INSPECTION

**CAUTION**

**NEVER** operate the PSH in a confined area or enclosed area structure that does not provide ample **free flow of air**.

**ALWAYS** wear approved eye and hearing protection before operating the PSH.



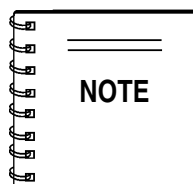

Reference manufacturer engine manual for specific servicing instructions.

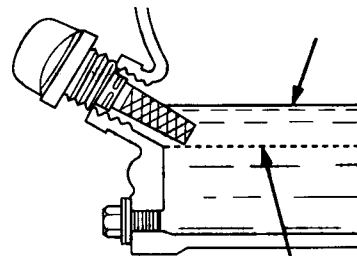

Figure 8. Engine Oil Dipstick (Oil Level)

### Before Starting

1. Read safety instructions at the beginning of manual.
2. Clean the PSH, removing dirt and dust, particularly the engine cooling air inlet, carburetor and air cleaner.
3. Check the air filter for dirt and dust. If air filter is dirty, replace air filter with a new one as required.
4. Check carburetor for external dirt and dust. Clean with dry compressed air.
5. Check fastening nuts and bolts for tightness.

### Engine Oil Check

1. To check the engine oil level, place the PSH on secure level ground with the engine stopped.
2. Remove the filler dipstick from the engine oil filler hole (Figure 7) and wipe clean.

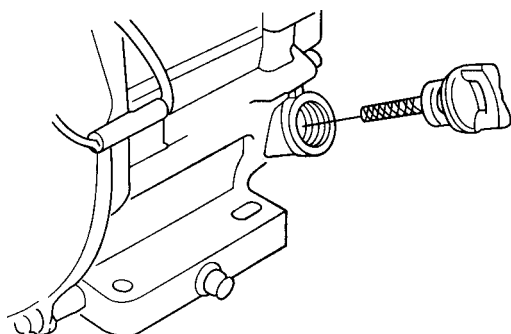

Figure 7. Engine Oil Dipstick (Removal)

3. Insert and remove the dipstick without screwing it into the filler neck. Check the oil level shown on the dipstick.
4. If the oil level is low (Figure 8), fill to the edge of the oil filler hole with the recommended oil type (Table 3). Maximum oil capacity is 0.59 quarts (.56 liters).

Table 3. Oil Type

Season	Temperature	Oil Type
Summer	25°C or Higher	SAE 10W-30
Spring/Fall	25°C~10°C	SAE 10W-30/20
Winter	0°C or Lower	SAE 10W-10

**DANGER**

**Fuel Check**

Motor fuels are highly flammable and can be dangerous if mishandled. **DO NOT** smoke while refueling. **DO NOT** attempt to refuel the PSH if the engine is **hot!** or **running**.



1. Remove the gasoline cap located on top of fuel tank.
2. Visually inspect to see if fuel level is low. If fuel is low, replenish with unleaded fuel.
3. When refueling, be sure to use a strainer for filtration. **DO NOT** top-off fuel. Wipe up any spilled fuel.

### V-Belt Check

A worn or damaged V-belt can adversely affect the performance of the PSH. If a V-belt is defective or worn simply replace the V-belt as outlined in the maintenance section of this manual.

# PORTO-SCREED PSH — INITIAL START-UP

## INITIAL START-UP

### Lifting and Moving the PSH

Even though the PSH is lightweight, always use two people when lifting or moving the PSH.

This section is intended to assist the operator with the initial start-up of the PSH. It is extremely important that this section be read carefully before attempting to use the PSH in the field.

**DO NOT** attempt to operate the PSH until the Safety, General Information and Inspection sections of this manual have been read and thoroughly understood.



### Starting the Engine

1. Place the engine ***fuel valve lever*** (Figure 9) to the "ON" position.

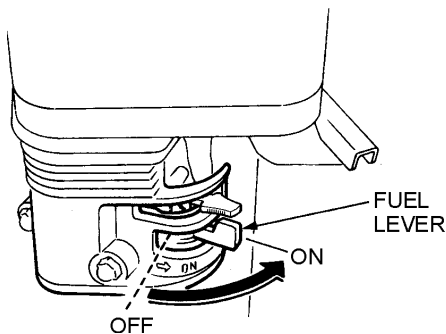

Figure 9. Engine Fuel Valve Lever

2. Place the trowel's ***throttle lever*** (Figure 10) to the "IDLE" position.

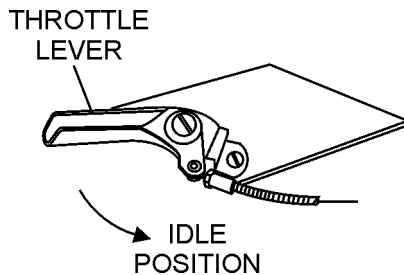

Figure 10. Throttle Lever (Idle Position)

3. Place the ***choke lever*** (Figure 11) in the "CLOSED" position if starting a ***cold*** engine.

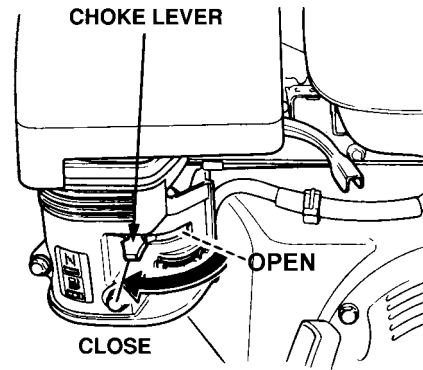

Figure 11. Engine Choke Lever

4. Place the ***choke lever*** (Figure 12) in the "OPEN" position if starting a ***warm engine*** or the ***temperature is warm***.

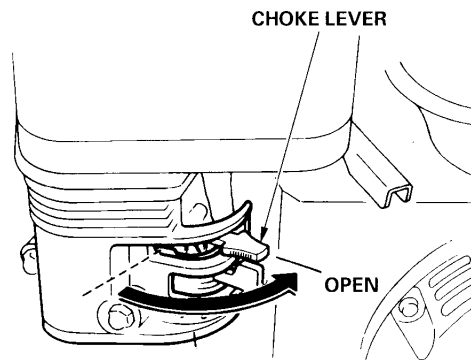

Figure 12. Engine Choke Lever (Open)

5. Place the ***engine ON/OFF switch*** (Figure 13) in the "ON" position.

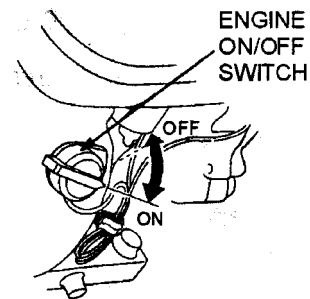

Figure 13. Engine ON/OFF Switch

## PORTO-SCREED PSH — INITIAL START-UP

6. Grasp the starter grip (Figure 14) and slowly pull it out. The resistance becomes the hardest at a certain position, corresponding to the compression point. Pull the starter grip briskly and smoothly for starting.

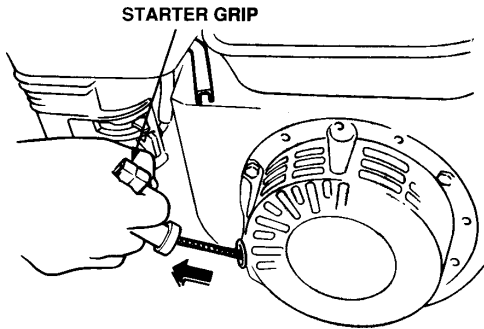

Figure 14. Starter Grip

7. If the engine has started, slowly return the choke lever (Figure 12) to the **OPEN** position. If the engine has not started repeat steps 1 through 6.
8. Before the PSH is placed into operation, run the engine for several minutes. Check for fuel leaks, and noises that would associate with a loose V-belt cover or component.

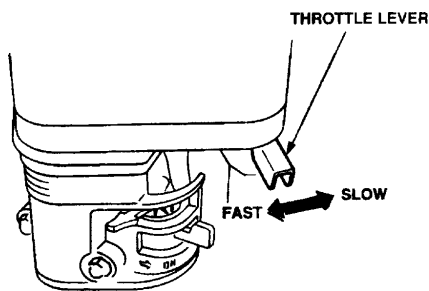

Figure 15. Throttle Lever (Run Position)

### Stopping The Engine

1. Move the throttle lever to the **IDLE** or **SLOW** position (Figure 15) and run the engine for three minutes at low speed.
2. After the engine **cools**, turn the engine start/stop switch to the "**OFF**" position (Figure 16).

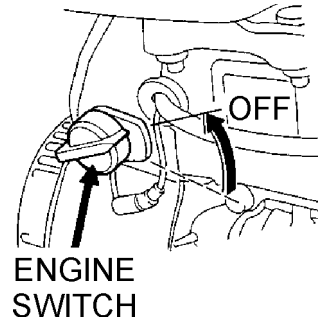

Figure 16. Engine ON/OFF Switch (OFF Position)

3. Close the **fuel shut-off valve** (Figure 17) by moving the fuel valve lever to the **OFF** position.

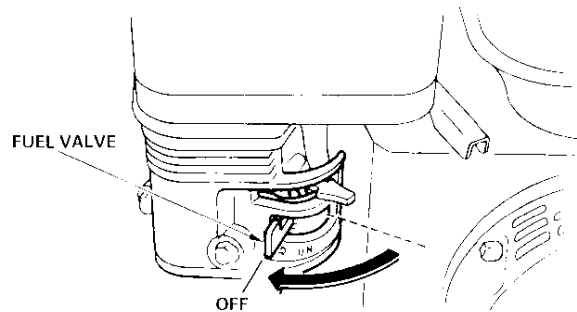

Figure 17. Fuel Valve Lever (OFF Position)

# PORTO-SCREED PSH — OPERATION

## OPERATION

1. Place the machine on the screeding beams (Items B, Figure 18) and install the clamping studs (Items A).

### CAUTION

Do not over tighten the clamping studs. Check the clamping studs periodically during operation and retighten them if they loosen.

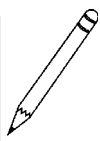
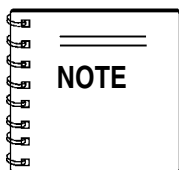

For beam lengths up to 14 ft. (4.2 meters) "2x4" wooden or lightweight beams are recommended. For longer lengths, up to 20 ft. (6 meters), "2x6" beams should be used.

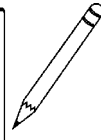
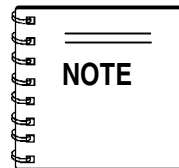

**DO NOT** alter this setting since damage to the eccentric bearings can result and both the engine and machine warranty will be automatically VOIDED.

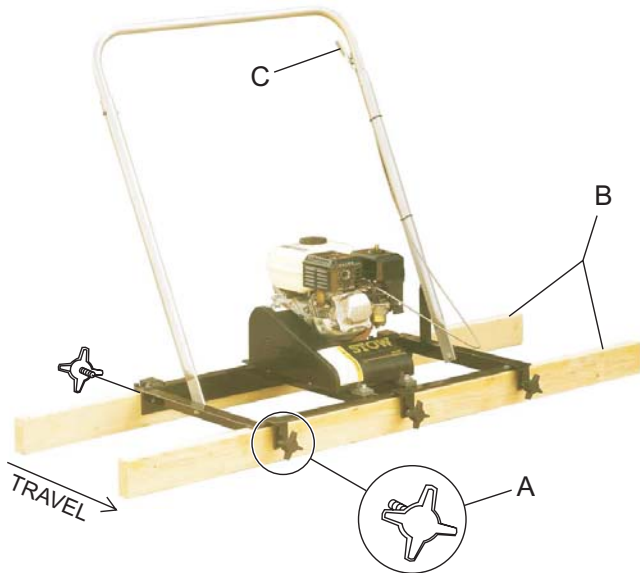

**Figure 18. Screeding Beams**

4. Start the engine as previously described. Refer to the Engine Manual Starting Instructions for complete starting instructions of the engine. Allow the engine to warm up 1-2 minutes before operating. The throttle lever should be set to permit the engine to warm up **WITHOUT** engaging the centrifugal clutch and causing the machine to vibrate and move forward under its own power.
5. To begin operation move the throttle lever (Item C, Figure 18) to the high speed or "Full Throttle" position quickly to prevent damage from occurring to the clutch. The "Full Throttle" position of this machine has been pre-set at the factory.

### Stopping The Engine

1. Move the throttle lever to the **IDLE** or **SLOW** position (Item C, Figure 15) and run the engine for three minutes at low speed.
2. After the engine **cools**, turn the engine start/stop switch to the "**OFF**" position (Figure 16).

2. Position the screed on the forms with the eccentric facing the desired direction of travel.
3. Pour the concrete into the forms to a height just above the bottom edge of the screeding beams and at least 10 ft. ahead of the unit.

## MAINTENANCE

See the engine manual supplied with your machine for appropriate engine maintenance schedule and troubleshooting guide for problems.



### CAUTION

**ALWAYS** allow the engine to cool before servicing. **NEVER** attempt any maintenance work on a **hot!** engine.



### WARNING

Whenever assembling, lubricating, cleaning or adjusting any part of the screed, make certain the engine is stopped with the spark plug wire disconnected and secured away from contact with the spark plug.

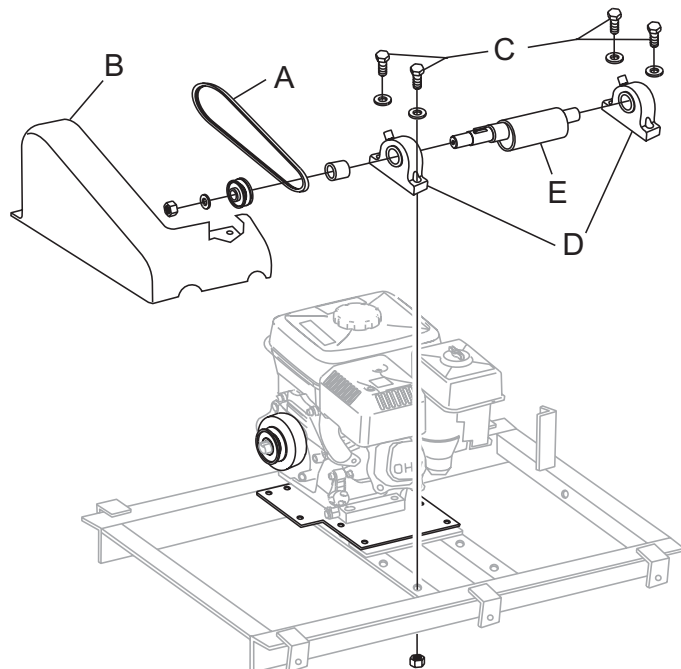

Figure 19. V-Belt Tensioning

## Lubrication

**A. Engine:** Lubricate the engine—refer to the “Engine Manual”. Always check the engine for proper level of engine oil. The engine warranty is VOID if run without oil. Check the oil level daily and change the oil weekly.

**B. Clutch:** A few drops of lightweight oil occasionally squirted between the clutch mechanism cover and the floating cone will help keep the mechanism free of debris and is the only clutch maintenance required

**C. Pillow Block Bearings:** After every 40 hours of operation, remove the belt guard (Item B, Figure 18) and grease each bearing (Item D) with quality grade multi-purpose grease.

## V-Belt Tensioning

To tension the V-Belt (Item A, Figure 19) perform the following:

1. Remove the belt guard (Item B).
2. Loosen the four (4) bolts (Item C) and slide the pillow block (Item D) away from or toward the engine to tighten or loosen the V-Belt until proper tension is achieved.

**NOTE:** Before retightening the pillow block bolts, be sure to align the eccentric assembly (Item E) perpendicular to the belt.

## Cleaning

Clean the machine following each screeding operation before concrete is allowed to dry on the machine. This is especially important on the clamping stud threads. Keeping the belt guard in place during operation not only provides a measure of safety, but also helps to protect the eccentric, centrifugal clutch, and belt from foreign matter.

## General

Check for broken or missing components before each use. Check all bolts for tightness before each use. Tighten if necessary.

## MAINTENANCE SCHEDULE

### Daily (8-10 Hours)

1. Check the oil level in the engine crankcase; fill as necessary.
2. Check V-belt.

### Weekly (50-60 Hours)

1. Check the engine air filter and replace as necessary.
2. Replace engine oil and filter as necessary, see engine manual.

# PORTO-SCREED PSH — TROUBLESHOOTING (ENGINE)

**TABLE 4. TROUBLESHOOTING (ENGINE)**

SYMPTOM	POSSIBLE CAUSE	SOLUTION
Difficult to start, "fuel is available, but no SPARK at spark plug".	Spark plug bridging?	Check gap, insulation or replace spark plug.
	Carbon deposit on spark plug?	Clean or replace spark plug.
	Short circuit due to deficient spark plug insulation?	Check spark plug insulation, replace if worn.
	Improper spark plug gap?	Set to proper gap.
Difficult to start, "fuel is available, and SPARK is present at the spark plug".	ON/OFF switch is shorted?	Check switch wiring, replace switch.
	Ignition coil defective?	Replace ignition coil.
	Improper spark gap, points dirty?	Set correct spark gap and clean points.
	Condenser insulation worn or short circuiting?	Replace condenser.
	Spark plug wire broken or short circuiting?	Replace defective spark plug wiring.
Difficult to start, "fuel is available, spark is present and compression is normal".	Wrong fuel type?	Flush fuel system, and replace with correct type of fuel.
	Water or dust in fuel system?	Flush fuel system.
	Air cleaner dirty?	Replace air cleaner.
	Choke Open? (Engine cold)	Close Choke.
	Choke Closed? (Engine warm)	Open Choke.
Difficult to start, "fuel is available, spark is present and compression is low".	Suction/exhaust valve stuck or protruded?	Re-seat valves.
	Piston ring and/or cylinder worn?	Replace piston rings and or piston.
	Cylinder head and/or spark plug not tightened properly?	Torque cylinder head bolts and spark plug.
	Head gasket and/or spark plug gasket damaged?	Replace head and spark plug gaskets.
No fuel present inside priming bulb.	Fuel not available in fuel tank?	Fill with correct type of fuel.
	Fuel filter clogged?	Replace fuel filter.
	Fuel tank cap breather hole clogged?	Clean or replace fuel tank cap.
	Air in fuel line?	Bleed fuel line.

# PORTO-SCREED PSH — SUGGESTED SPARE PARTS

SUGGESTED SPARE PARTS

## PORTO-SCREED PSH

1 TO 3 UNITS WITH HONDA GX120K1QX2 ENGINE

### *1 to 3 Units*

Qty.....	P/N .....	Description
1 .....	30033-401 .....	CABLE, THROTTLE ASM
4 .....	22094-006 .....	O-RING (FASTENER)
4 .....	1162 A .....	CAP, GREASE ZERK
3 .....	07055-028 .....	V-BELT 4L280
3 .....	19977 .....	KNOB, CLAMP
1 .....	17620ZH7023 .....	TANK CAP (HONDA)
2 .....	17210ZE1505 .....	AIR CLEANER ELEMENT
3 .....	9807956846 .....	SPARK PLUG
1 .....	28462ZH8003 .....	ROPE, RECOIL STARTER

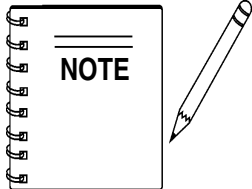

*The contents of this parts catalog  
are subject to change without  
notice.*

# PORTO-SCREED PSH — NAMEPLATE AND DECALS

## NAMEPLATE AND DECALS

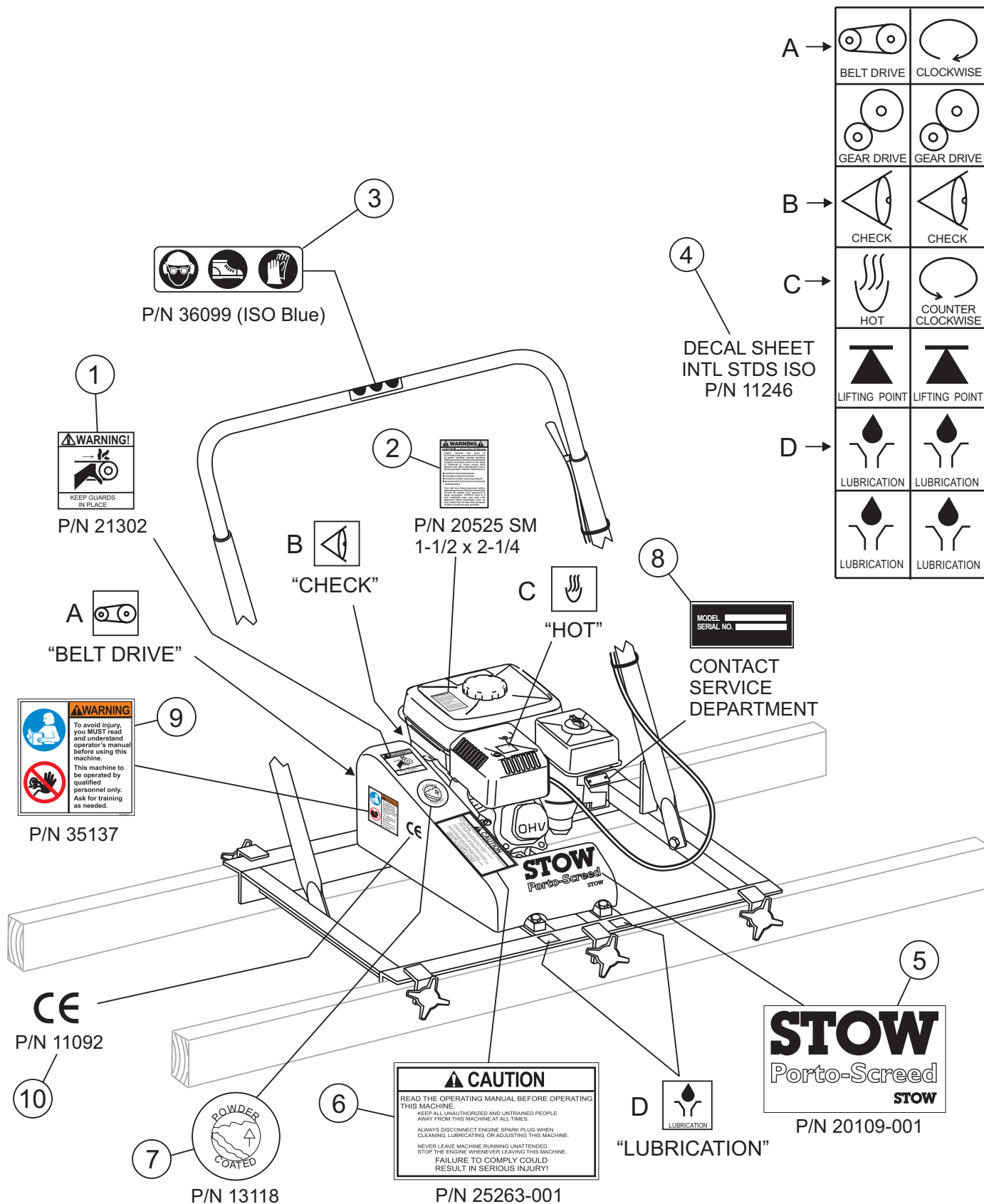

# PORTO-SCREED PSH — NAMEPLATE AND DECALS

## NAMEPLATE AND DECALS

<u>NO.</u>	<u>PART NO.</u>	<u>PART NAME</u>	<u>QTY.</u>	<u>REMARKS</u>
1	21302	DECAL: GUARD WARNING .....	1 .....	SAFETY ITEM
2	20525 SMALL	DECAL: WARNING, CA PROP 65 .....	1 .....	SAFETY ITEM
3	36099	DECAL: HELMET, SHOE AND GLOVE .....	1 .....	SAFETY ITEM
4	11246	DECAL: SHEET-INTERNATIONAL STANDARDS ..	1 .....	SAFETY ITEM
5	20109-001	DECAL: STOW PORTO-SCREED	1	
6	25263-001	DECAL: CAUTION GAS VIB .....	1 .....	SAFETY ITEM
7	13118	DECAL: POWDER COATED	1	
8		NAME PLATE .....	1 .....	CONTACT PARTS DEPARTMENT
9	35137	DECAL: WARNING, READ MANUAL .....	1 .....	SAFETY ITEM
10	11092	DECAL: CE	1	

SEE DECAL ILLUSTRATIONS ON PAGE 11

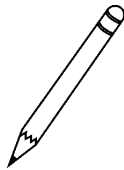
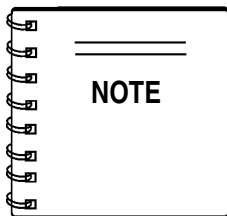

**The contents of this parts catalog are subject to change without notice.**

# PORTO-SCREED PSH — ASSEMBLY

## ASSEMBLY

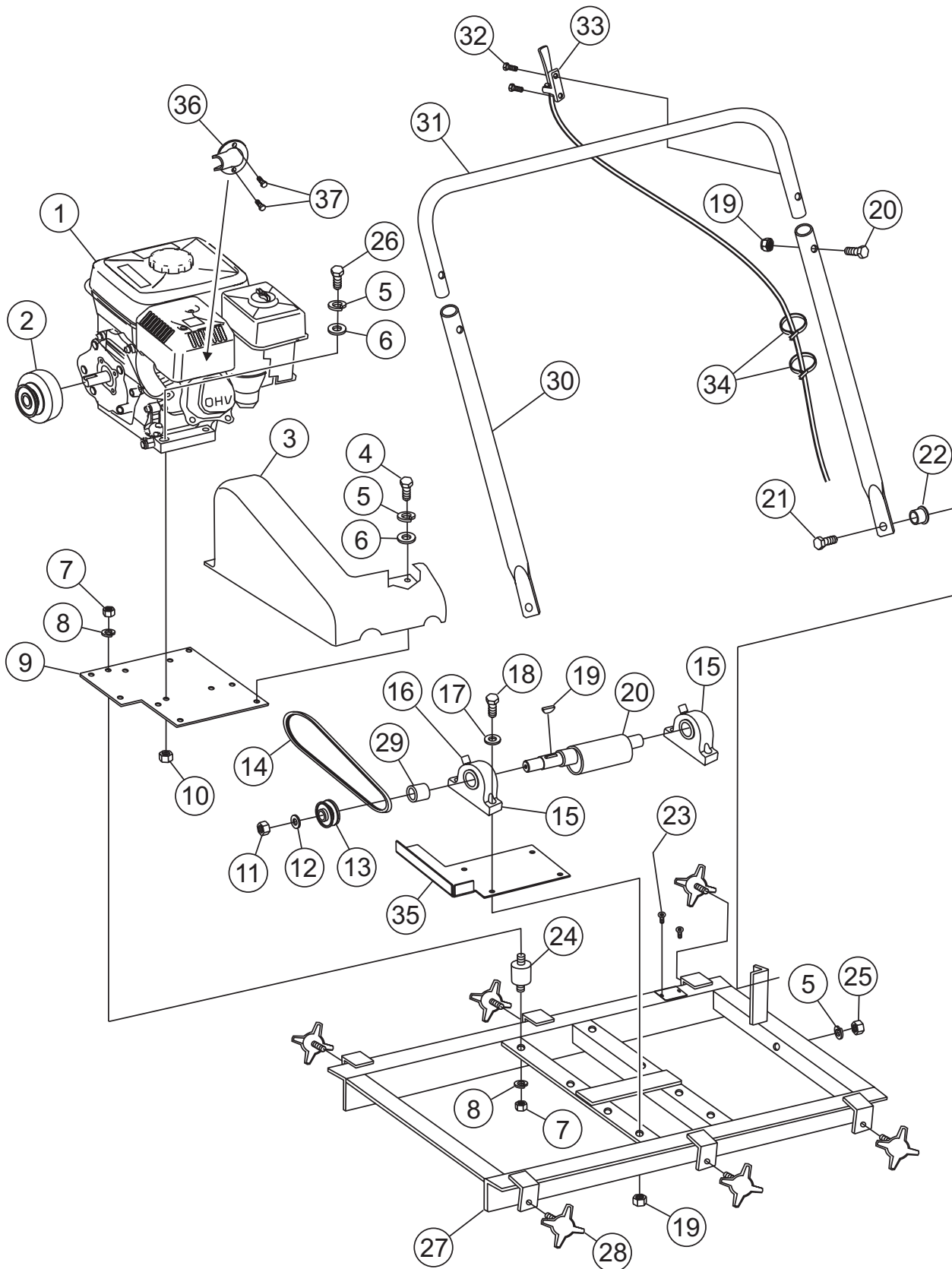

# PORTO-SCREED PSH — ASSEMBLY

## ASSEMBLY

<u>NO.</u>	<u>PART NO.</u>	<u>PART NAME</u>	<u>QTY.</u>	<u>REMARKS</u>
1	21387	ENGINE, 4 HP. HONDA GX120K1QX2	1	
2	12704-304	CLUTCH	1	
3	18241-301	BELT GUARD .....	1	SAFETY ITEM
4	0655	SCREW, HHC 5/16 - 18 X 3/4"	3	
5	0161 C	LOCK WASHER 5/16"	9	
6	0300 B	FLAT WASHER 5/16"	7	
7	0949	HEX NUT 1/4- 20	8	
8	0181 B	LOCK WASHER 1/4"	8	
9	15488-001	PLATE, ENGINE MOUNT	1	
10	5283	NUT, NYLOC 5/16 - 18	4	
11	08297-008	NUT, LOCK 1/2 - 20 GRIPCO	1	
12	0477	FLATWASHER, 1/2	1	
13	36493	PULLEY, AS20 X 5/8	1	
13A	07051-017	PULLEY, 1/8" KEYWAY .....	1	SERVICE ONLY
14	07055-028	V-BELT4L280	1	
15	27023-001	BEARING, P-BLOCK	2	
16	1162 A	CAP, GREASE ZERK #2	2	
17	4001	FLAT WASHER 3/8"	4	
18	1284	SCREW, HHCS 3/8- 16 X 1"	1	
19	36494	KEY WOODRUFF #6	1	
20	21101-002	SPINDLE, ECCENTRIC	1	
21	0202	SCREW, HHC 5/16 - 18 X 3/4"	2	
22	13658-001	SPACER, HANDLE	2	
23	4014	SCREW, 2 - 3/16 P-K TYPE U-DRIVE	2	
24	11679-001	MOUNT, ISOLATION	4	
25	0161 D	NUT, HEX 5/16 X 18	2	
26	0105	SCREW, HHC 5/16- 18 X 1-1/2"	4	
27	12706-401	FRAME	1	
28	19977	KNOB, CLAMP	6	
29	11831-001	SPACER, ECCENTRIC PULLEY	1	
30	36491	TUBE, HANDLE LEG	2	
31	36492	TUBE, HANDLE	1	
32	12714-006	SCREW, PHSHT METAL 10 X 3/8 SLOTTED	2	
33	30033-401	CABLE, THROTTLE ASM	1	
34	22094-006	O-RING	2	
35	36499	PLATE, LOWER BELT GUARD .....	1	SAFETY ITEM
36	1834	DEFLECTOR, EXHAUST .....	1	SAFETY ITEM
37	1273	SCREW, HHST 8-32 X 3/8	2	

# STOW

A DIVISION OF MULTIQUIP INC.

## Terms and Conditions of Sale STOW Construction Equipment

### PAYMENT TERMS

Terms of payment for unit sales are 2% 15 days net 30 days from date of invoice unless otherwise specifically stated on our invoice. Parts invoices have terms of net 10 days. **Minimum parts billing is \$15.00 net.**

Applicable discounts will be computed on merchandise value only. Late charges will be assessed at prevailing rates. Cash discounts cannot be taken on current billings if any previously billed amounts are past due.

### FREIGHT POLICY

Freight policy is established to offer customers every advantage possible. Due to bulk freight ratings on some equipment and other shipping considerations, freight policies differ by equipment type. Actual back freight may be charged for shipments originating from other than specified FOB warehouses. **See Freight Policy for details.**

All STOW domestic sales are FOB nearest available designated MQ/STOW warehouse. Export orders are ex-works factory located in Carson, CA or Boise, ID.

Additions to orders already shipped cannot be accepted for freight minimums.

Should STOW elect to make partial shipments of an order originally complying with the "freight allowed" requirements, transportation charges will be absorbed by STOW on any subsequent shipment applying to that order.

All other orders will be shipped collect or prepaid with charges added to the invoice. STOW's responsibility ceases when a signed manifest has been obtained from the carrier, and any claim for shortage or damage must be settled between the consignee and the carrier.

**Parts:** FOB Carson, California or Boise, Idaho. **See Freight Policy for details and additional discounts.**

### DROP SHIPMENTS

STOW reserves the right to refuse Drop Shipments outside the normal service area of the purchasing dealer.

### FIELD WAREHOUSES

Field Warehouses are currently located in California, Georgia, Idaho, Iowa, and New Jersey

### SPECIAL EXPEDITING SERVICE

The higher of a \$35.00 surcharge or actual costs will be added to the invoice for special handling, including bus shipments, or in cases where STOW personnel must personally deliver the equipment or parts to the carrier.

### RETURNED GOODS POLICY

Return shipments may be accepted and credit allowed, subject to the following provisions.

1. A Returned Material Authorization (RMA) must be approved by STOW prior to shipment. Approvals for returned goods must be with just cause and are at the sole discretion of STOW. A copy of the Authorization must accompany the shipment to the designated Warehouse.
2. Parts being returned must be listed as currently supplied on the current parts list.
3. Parts must be in new and resalable condition in the original package, with part numbers clearly marked.
4. Units and accessories must be current models in the latest price list and in new and resalable condition.
5. Special order items are not returnable for credit.
6. Credit on returned parts and units will be issued at actual dealer net price at time of purchase less 15% restocking charge.
7. All returned shipments are to be made to the STOW designated receiving point, freight prepaid at the sender's expense.

The sender will be notified of any material received that does not meet the above provisions. Such material will be held for 30 days from notification pending instructions. If a reply is not received within 30 days, the material will be returned to the sender at his expense with no credit issued.

### PRICING, REBATES AND SPECIFICATIONS

Every effort will be made to provide adequate notice of changes; however, prices and equipment specifications are subject to change without notice.

Price changes are effective on a specific date and all orders received on or after that date will be billed at the revised price.

Rebates for price reductions and added charges for price increases will not be made for stock in dealer inventory at the time of a price change. STOW reserves the right to quote and sell direct to Government agencies and to Original Equipment Manufacturer accounts who use our products as integral parts of their own products.

### LIMITATION OF SELLER'S LIABILITY

STOW shall not be liable hereunder for damages in excess of the purchase price of the item with respect to which damages are claimed and in no event shall STOW be liable for loss of profit or good will or for any other special, consequential or incidental damages.

### LIMITATION OF WARRANTIES

There are no warranties, express or implied, made by STOW hereunder on Products manufactured or distributed by it except the warranty against defects in material and workmanship on new Products to the original purchaser, as set forth in the STOW New Product Limited Warranty.

# STOW

A DIVISION OF MULTIQUIP INC.

Atlanta • Boise • Newark • Quebec, Canada  
Manchester, UK • Rio de Janeiro, BR • Puebla, MX

### STOW CONSTRUCTION EQUIPMENT

POST OFFICE BOX 6254  
CARSON, CALIFORNIA 90749  
310-661-4242 • 877-BUY-STOW  
FAX: 310-604-9237  
E-MAIL: stow@stowmfg.com  
www.stowmfg.com



# OPERATION AND PARTS MANUAL

## **HERE'S HOW TO GET HELP**

*PLEASE HAVE THE MODEL AND SERIAL NUMBER ON-HAND WHEN CALLING*

### **PARTS DEPARTMENT**

*800-427-1244 or 310-537-3700*

*FAX: 800-672-7877 or 310-637-3284*

### **SERVICE DEPARTMENT**

*800-421-1244*

*FAX: 310- 537-4259*

### **TECHNICAL ASSISTANCE**

*800-478-1244*

*FAX: 310- 631-5032*

### **WARRANTY DEPARTMENT**

*888-661-4279, or 310-661-4279*

*FAX: 310- 537-1173*

**STOW**  
A DIVISION OF MULTQUIP INC.

#### **STOW CONSTRUCTION EQUIPMENT**

*A DIVISION OF MULTQUIP INC.*

*POST OFFICE BOX 6254*

*CARSON, CA 90749*

*310-537-3700 • 888-252-STOW [888-252-7869]*

*FAX: 310-537-1986 • FAX: 800-556-1986*

*E-MAIL: stow@multiquip.com • WWW: stowmfg.com*

#### **PARTS DEPARTMENT:**

*800-427-1244*

*FAX: 800-672-7877*

#### **SERVICE DEPARTMENT/TECHNICAL ASSISTANCE:**

*800-478-1244*

*FAX: 310-631-5032*