

# OPERATION AND PARTS MANUAL





*Mikasa* SERIES  
**MODEL MVC77**  
**ONE-WAY PLATE COMPACTOR**  
**(HONDA GX160K1QX2 GASOLINE ENGINE)**

Revision #4 (01/14/11)

To find the latest revision of this  
publication, visit our website at:  
[www.multiquip.com](http://www.multiquip.com)



**THIS MANUAL MUST ACCOMPANY THE EQUIPMENT AT ALL TIMES.**

 <b>WARNING</b> 
<b>CALIFORNIA — Proposition 65 Warning</b> Engine exhaust and some of its constituents are known to the State of California to cause cancer, birth defects and other reproductive harm.



# TABLE OF CONTENTS

## MVC77 Plate Compactor

Proposition 65 Warning .....	2
Table Of Contents .....	4
Parts Ordering Procedures .....	5
Safety Information .....	6-10
Specifications .....	11
General Information .....	12
Components .....	13
Basic Engine .....	14
Inspection .....	15-16
Startup .....	17-18
Operation .....	19
Maintenance .....	20-21
Preparation For Long Term Storage .....	22
Troubleshooting .....	23-25
Explanation Of Codes In Remarks Column .....	26
Suggested Spare Parts .....	27

## Honda GX160K1QX2 Engine

Cylinder Head Assembly .....	40-41
Cylinder Barrel (Recoil) Assembly .....	42-43
Crankcase Cover Assembly .....	44-45
Crankshaft Assembly .....	46-47
Piston/Rings Assembly .....	48-49
Camshaft Assembly .....	50-51
Recoil Starter .....	52-53
Fan Cover Assembly .....	54-55
Carburetor Assembly .....	56-57
Air Cleaner Assembly .....	58-59
Muffler Assembly .....	60-61
Fuel Tank Assembly .....	62-63
Cooling Fan & Flywheel Assembly .....	64-65
Ignition Coil Assembly .....	66-67
Control Assembly .....	68-69
Terms and Conditions Of Sale — Parts .....	70

## Component Drawings

Name Plate and Decals .....	28-29
Main Body Assembly .....	30-31
Engine Pulley/Clutch Assembly .....	32-33
Vibrator/Plate Mounting Assembly .....	34-35
Vibrator Assembly .....	36-37
Water Tank .....	38-39

### NOTICE

*Specification and part number are subject to change without notice.*

# PARTS ORDERING PROCEDURES

## Ordering parts has never been easier! Choose from three easy options:

Effective:  
January 1<sup>st</sup>, 2006

www.multiquip.com



### Order via Internet (Dealers Only):

Order parts on-line using Multiquip's SmartEquip website!

- View Parts Diagrams
- Order Parts
- Print Specification Information



If you have an MQ Account, to obtain a Username and Password, E-mail us at: [parts@multiquip.com](mailto:parts@multiquip.com).

To obtain an MQ Account, contact your District Sales Manager for more information.

Goto [www.multiquip.com](http://www.multiquip.com) and click on

**Order Parts** to log in and save!

Use the **internet** and qualify for a **5% Discount** on *Standard orders* for all orders which include complete part numbers.\*

Note: Discounts Are Subject To Change

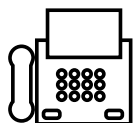

### Order via Fax (Dealers Only):

All customers are welcome to order parts via Fax.

**Domestic (US) Customers dial:**

1-800-6-PARTS-7 (800-672-7877)

**Fax** your order in and qualify for a **2% Discount** on *Standard orders* for all orders which include complete part numbers.\*

Note: Discounts Are Subject To Change



**Order via Phone: Domestic (US) Dealers Call:**

1-800-427-1244

### Non-Dealer Customers:

Contact your local Multiquip Dealer for parts or call 800-427-1244 for help in locating a dealer near you.



**International Customers** should contact their local Multiquip Representatives for Parts Ordering information.

## When ordering parts, please supply:

- |   |  |
|---|--|
| <input type="checkbox"/> Dealer Account Number                                | <input type="checkbox"/> Specify Preferred Method of Shipment:                         |
| <input type="checkbox"/> Dealer Name and Address                              | <input checked="" type="checkbox"/> UPS/Fed Ex <input checked="" type="checkbox"/> DHL |
| <input type="checkbox"/> Shipping Address (if different than billing address) | <input type="checkbox"/> Priority One <input checked="" type="checkbox"/> Truck        |
| <input type="checkbox"/> Return Fax Number                                    | <input type="checkbox"/> Ground  |
| <input type="checkbox"/> Applicable Model Number                              | <input type="checkbox"/> Next Day  |
| <input type="checkbox"/> Quantity, Part Number and Description of Each Part   | <input type="checkbox"/> Second/Third Day  |

### NOTICE

All orders are treated as *Standard Orders* and will ship the same day if received prior to 3PM PST.

WE ACCEPT ALL MAJOR CREDIT CARDS!



# SAFETY INFORMATION

Do not operate or service the equipment before reading the entire manual. Safety precautions should be followed at all times when operating this equipment. Failure to read and understand the safety messages and operating instructions could result in injury to yourself and others.



## SAFETY MESSAGES

The four safety messages shown below will inform you about potential hazards that could injure you or others. The safety messages specifically address the level of exposure to the operator and are preceded by one of four words: **DANGER**, **WARNING**, **CAUTION** or **NOTICE**.

## SAFETY SYMBOLS

**! DANGER**

Indicates a hazardous situation which, if not avoided, **WILL** result in **DEATH** or **SERIOUS INJURY**.

**! WARNING**

Indicates a hazardous situation which, if not avoided, **COULD** result in **DEATH** or **SERIOUS INJURY**.

**! CAUTION**

Indicates a hazardous situation which, if not avoided, **COULD** result in **MINOR** or **MODERATE INJURY**.

**NOTICE**

Addresses practices not related to personal injury.

Potential hazards associated with the operation of this equipment will be referenced with hazard symbols which may appear throughout this manual in conjunction with safety messages.

Symbol	Safety Hazard
	Lethal exhaust gas hazards
	Explosive fuel hazards
	Burn hazards
	Respiratory hazards
	Accidental starting hazards
	Eye and hearing hazards
	Rotating parts hazards

# SAFETY INFORMATION

## GENERAL SAFETY

### CAUTION

- **NEVER** operate this equipment without proper protective clothing, shatterproof glasses, respiratory protection, hearing protection, steel-toed boots and other protective devices required by the job or city and state regulations.



- **NEVER** operate this equipment when not feeling well due to fatigue, illness or when under medication.



- **NEVER** operate this equipment under the influence of drugs or alcohol.



- **ALWAYS** check the equipment for loosened threads or bolts before starting.
- **DO NOT** use the equipment for any purpose other than its intended purposes or applications.
- **ALWAYS** clear the work area of any debris, tools, etc. that would constitute a hazard while the equipment is in operation.

### NOTICE

- This equipment should only be operated by trained and qualified personnel 18 years of age and older.
- Whenever necessary, replace nameplate, operation and safety decals when they become difficult read.
- Manufacturer does not assume responsibility for any accident due to equipment modifications. Unauthorized equipment modification will void all warranties.
- **NEVER** use accessories or attachments that are not recommended by Multiquip for this equipment. Damage to the equipment and/or injury to user may result.
- **ALWAYS** know the location of the nearest **fire extinguisher**.
- **ALWAYS** know the location of the nearest **first aid kit**.
- **ALWAYS** know the location of the nearest phone or **keep a phone on the job site**. Also, know the phone numbers of the nearest **ambulance, doctor and fire department**. This information will be invaluable in the case of an emergency.

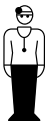

# SAFETY INFORMATION

## COMPACTOR SAFETY

### DANGER

- **NEVER** operate the equipment in an explosive atmosphere or near combustible materials. An explosion or fire could result causing severe **bodily harm or even death.**



### WARNING

- **NEVER** disconnect any **emergency or safety devices.** These devices are intended for operator safety. Disconnection of these devices can cause severe injury, bodily harm or even death. Disconnection of any of these devices will void all warranties.

### CAUTION

- **NEVER** lubricate components or attempt service on a running machine.

### NOTICE

- **ALWAYS** keep the machine in proper running condition.
- Fix damage to machine and replace any broken parts immediately.
- **ALWAYS** store equipment properly when it is not being used. Equipment should be stored in a clean, dry location out of the reach of children and unauthorized personnel.

## ENGINE SAFETY

### DANGER

- The engine fuel exhaust gases contain poisonous carbon monoxide. This gas is colorless and odorless, and can cause death if inhaled.
- The engine of this equipment requires an adequate free flow of cooling air. **NEVER** operate this equipment in any enclosed or narrow area where free flow of the air is restricted. If the air flow is restricted it will cause injury to people and property and serious damage to the equipment or engine.



### WARNING

- **DO NOT** place hands or fingers inside engine compartment when engine is running.
- **NEVER** operate the engine with heat shields or guards removed.
- Keep fingers, hands hair and clothing away from all moving parts to prevent injury.
- **DO NOT** remove the radiator cap while the engine is hot. High pressure boiling water will gush out of the radiator and severely scald any persons in the general area of the compactor.
- **DO NOT** remove the coolant drain plug while the engine is hot. Hot coolant will gush out of the coolant tank and severely scald any persons in the general area of the compactor.
- **DO NOT** remove the engine oil drain plug while the engine is hot. Hot oil will gush out of the oil tank and severely scald any persons in the general area of the compactor.



### CAUTION

- **NEVER** touch the hot exhaust manifold, muffler or cylinder. Allow these parts to cool before servicing equipment.



### NOTICE

- **NEVER** run engine without an air filter or with a dirty air filter. Severe engine damage may occur. Service air filter frequently to prevent engine malfunction.
- **NEVER** tamper with the factory settings of the engine or engine governor. Damage to the engine or equipment can result if operating in speed ranges above the maximum allowable.
- **NEVER** tip the engine to extreme angles during lifting as it may cause oil to gravitate into the cylinder head, making the engine start difficult.





# SAFETY INFORMATION

## FUEL SAFETY

### DANGER

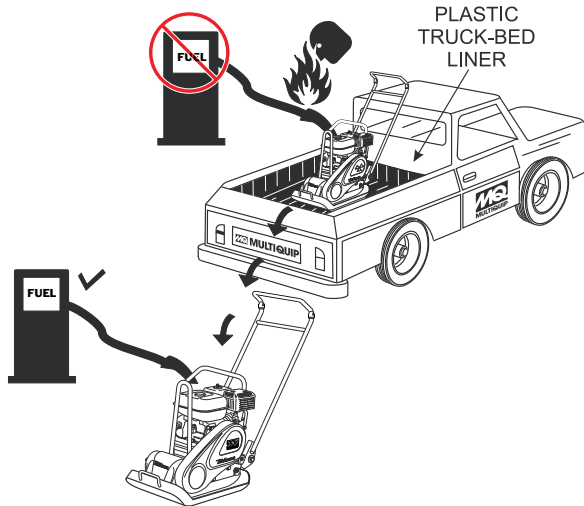
- **DO NOT** add fuel to equipment if it is placed inside truck bed with plastic liner. Possibility exists of explosion or fire due to static electricity.





- **DO NOT** start the engine near spilled fuel or combustible fluids. Diesel fuel is extremely flammable and its vapors can cause an explosion if ignited.
- **ALWAYS** refuel in a well-ventilated area, away from sparks and open flames.
- **ALWAYS** use extreme caution when working with **flammable** liquids.
- **DO NOT** fill the fuel tank while the engine is running or hot.
- **DO NOT** overfill tank, since spilled fuel could ignite if it comes into contact with hot engine parts or sparks from the ignition system.
- Store fuel in appropriate containers, in well-ventilated areas and away from sparks and flames.
- **NEVER** use fuel as a cleaning agent.
- **DO NOT** smoke around or near the equipment. Fire or explosion could result from fuel vapors or if fuel is spilled on a hot engine. 

## BATTERY SAFETY (ELECTRIC START ONLY)

### DANGER

- **DO NOT** drop the battery. There is a possibility that the battery will explode.
- **DO NOT** expose the battery to open flames, sparks, cigarettes, etc. The battery contains combustible gases and liquids. If these gases and liquids come into contact with a flame or spark, an explosion could occur. 

### WARNING

- **ALWAYS** wear safety glasses when handling the battery to avoid eye irritation. The battery contains acids that can cause injury to the eyes and skin. 
- Use well-insulated gloves when picking up the battery.
- **ALWAYS** keep the battery charged. If the battery is not charged, combustible gas will build up.
- **DO NOT** charge battery if frozen. Battery can explode. When frozen, warm the battery to at least 61°F (16°C).
- **ALWAYS** recharge the battery in a well-ventilated environment to avoid the risk of a dangerous concentration of combustible gases.
- If the battery liquid (dilute sulfuric acid) comes into contact with **clothing or skin**, rinse skin or clothing immediately with plenty of water. 
- If the battery liquid (dilute sulfuric acid) comes into contact with **eyes**, rinse eyes immediately with plenty of water and contact the nearest doctor or hospital to seek medical attention.

### CAUTION

- **ALWAYS** disconnect the **NEGATIVE battery terminal** before performing service on the equipment.
- **ALWAYS** keep battery cables in good working condition. Repair or replace all worn cables.

## TRANSPORTING SAFETY

### CAUTION

- NEVER allow any person or animal to stand underneath the equipment while lifting.

### NOTICE

- Before lifting, make sure that the equipment parts (hook and vibration insulator) are not damaged and screws are not loose or missing.
- Always make sure crane or lifting device has been properly secured to the lifting bail (hook) of the equipment.
- **ALWAYS** shutdown engine before transporting.
- **NEVER** lift the equipment while the engine is running.
- Tighten fuel tank cap securely and close fuel cock to prevent fuel from spilling.
- Use adequate lifting cable (wire or rope) of sufficient strength.
- Use one point suspension hook and lift straight upwards.
- **DO NOT** lift machine to unnecessary heights.
- **ALWAYS** tie down equipment during transport by securing the equipment with rope.

## ENVIRONMENTAL SAFETY

### NOTICE

- Dispose of hazardous waste properly. Examples of potentially hazardous waste are used motor oil, fuel and fuel filters. 
- **DO NOT** use food or plastic containers to dispose of hazardous waste.
- **DO NOT** pour waste, oil or fuel directly onto the ground, down a drain or into any water source.

**TABLE 1. COMPACTOR SPECIFICATIONS**

Model	MVC-77, S, H and SH
Centrifugal Force	3,350 lbs. (1520 kg)
Number of Vibrations	5,800 vibrations/min
Traveling Speed	82 meters/min (82 ft./min)
Plate Size (LxW)	.49 x .57 cm (17 x 22 in.)
Operating Weight Operating Weight (Water Tank)	166 lbs. (75.0 kg.) 195 lbs. ( 88.4 kg.)
Water Tank Capacity	13.7 qt.
Max. Area Of Compaction	6970 sq. ft./hr.

**TABLE 2. ENGINE SPECIFICATIONS**

Engine Make	HONDA	ROBIN
Engine Model	GX160K1QX2	EH172YD4020
Engine Type	OHV Gasoline Engine	OHV Gasoline Engine
Number Of Cylinders	1	1
Bore/Stroke	68 MM X 45 MM (2.70 IN X 1.8 IN)	67 MM X 49 MM (2.64 IN X 1.93 IN)
Displacement	163 cc (9.9 cu. in)	172 cc (10.50 cu. in)
Maximum Output	5.5 H.P./3,600 rpm	6.0 H.P./4,000 rpm
Oil Grade	See Table 3	See Table 3
Oil Capacity	1.3 pints/0.6 liters	1.3 pints/0.6 liters
Fuel Type	Unleaded	Unleaded
Fuel Tank Capacity	3.8 qt./3.6 liters	3.8 qt./3.6 liters
Dry Weight	15 kg/33 lbs.	16 kg/35 lbs.
Starting Method	Recoil Start	Recoil Start

# GENERAL INFORMATION

---

## Definition of Plate Compactor

The Mikasa MVC77 Series is a walk behind, plate compactor designed for the compaction of sand, mixed soils and asphalt. This plate compactor is a powerful compacting tool capable of applying a tremendous force in consecutive high frequency vibrations to a soil surface. Its applications include compacting for road, embankments and reservoirs as well as backfilling for gas pipelines, water pipelines and cable installation work.

## Vibratory Plates

The vibratory plates of the compactor produce low amplitude high frequency vibrations, designed to compact granular soils and asphalt.

The resulting vibrations cause forward motion. The engine and handle are vibration isolated from the vibrating plate.

## Frequency/Speed

The compactor's vibrating plate has a frequency range between 5,800 vpm (vibrations per minute). The forward and reverse travel speed of the compactor is approximately 23 meters/minute (75 ft./minute).

## Engine

The Mikasa MVC77 Series Plate Compactor is equipped with either a Honda or Robin air cooled, 4-cycle gasoline engine. The engine drives an eccentric weight at a high speed to develop a compaction force.

## Controls

Before starting the MVC77 Series Plate Compactor identify and understand the function of the controls and components as indicated on page 13 (Figure 1).

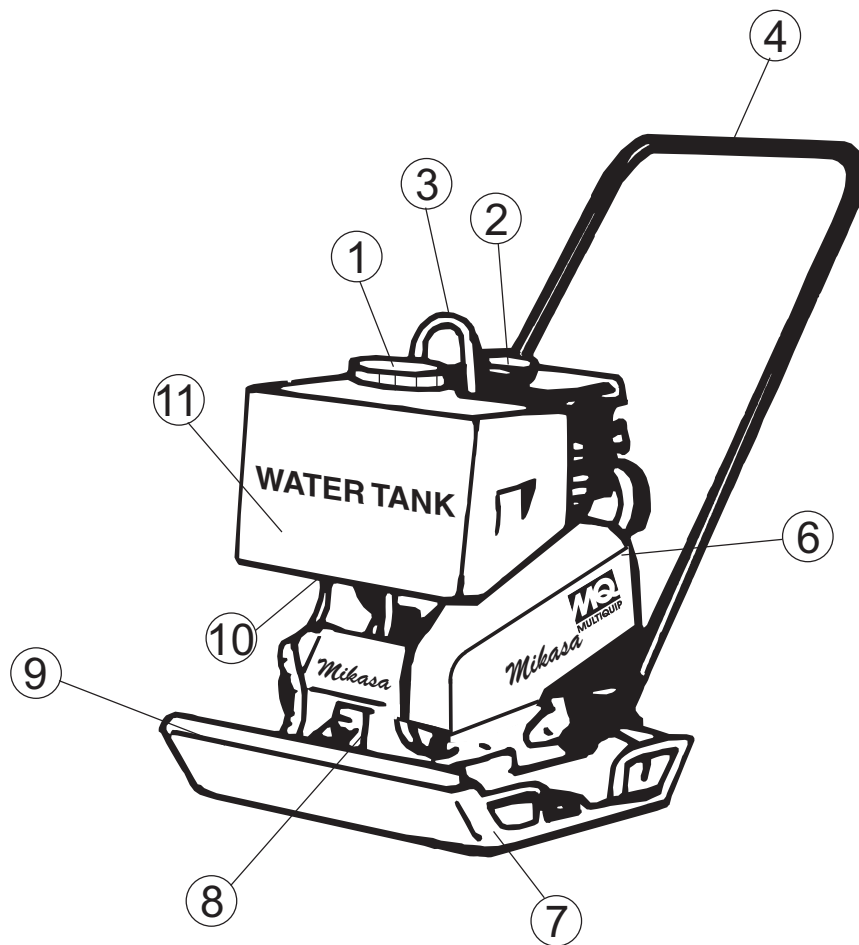

Figure 1. MVC77 Series Plate Compactor Components

Figures 1 and 2 shows the location of the components and general maintenance parts. The function of each component is described below:

1. **Water Tank Cap** – Remove this cap to add water to the water tank.
2. **Fuel Tank Cap** – Remove this cap to add fuel.
3. **Lifting Bale** – When lifting of the compactor is required either by forklift, crane etc., tie rope or chain around this lifting point.
4. **Handle Bar** – When operating the compactor use this handle bar to maneuver the compactor.
5. **Gasoline Engine** – This plate compactor uses a HONDA GX160K1QX2 or ROBIN EH172YD4020 engine. Refer to the HONDA or ROBIN owners manual for engine information and related topics.
6. **Belt Cover** – Remove this cover to gain access to the V-belts. **NEVER** run the compactor without the V-belt cover. If the V-belt cover is not installed, the possibility exist that your hand may get caught between the V-belt and clutch, thus causing serious injury and bodily harm.
7. **Vibrating Plate** – A flat, open plate made of durable cast iron construction used in the compacting of soil.
8. **Vibration Case** – Encloses the eccentric, gears and counter weights.
9. **Water Tube (Sprinkler)** – Supplies water to the soil via a splash plate.
10. **Water Shut-Off Valve** – Turn this valve downward to let water flow from the water tank to the water tube.
11. **Water Tank** – Holds 13.7 quarts of water, removable no tools required.

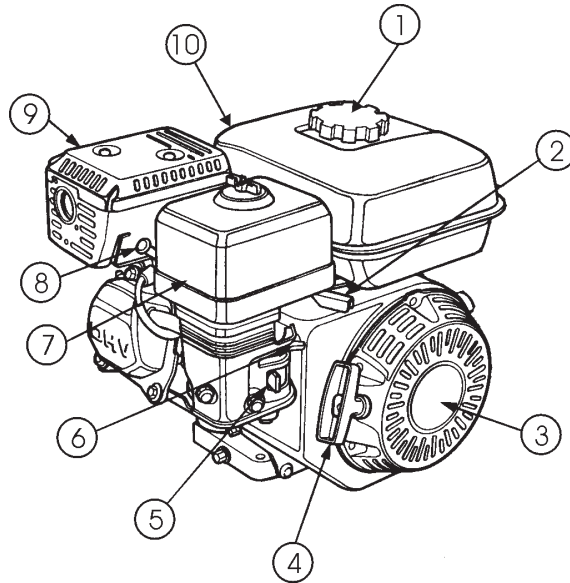

Figure 2. Engine Controls & Components

## INITIAL SERVICING

The engine (Figure 2) must be checked for proper lubrication and filled with fuel prior to operation. Refer to the manufacturers Engine manual for instructions & details of operation and servicing.

1. **Fuel Filler Cap** – Remove this cap to add unleaded gasoline to the fuel tank. Make sure cap is tightened securely. **DO NOT** over fill.

### WARNING



Add fuel to the tank only when the engine is stopped and has cooled down. In the event of a fuel spill, **DO NOT** attempt to start the engine until the fuel residue has been completely wiped up and the area surrounding the engine is dry.

2. **Throttle Lever** – Used to adjust engine RPM speed (lever advanced forward **SLOW**, lever back toward operator **FAST**).
3. **Engine ON/OFF Switch** – ON position permits engine starting, OFF position stops engine operations.
4. **Recoil Starter (pull rope)** – Manual-starting method. Pull the starter grip until resistance is felt, then pull briskly and smoothly.
5. **Fuel Valve Lever** – **OPEN** to let fuel flow, **CLOSE** to stop the flow of fuel.

6. **Choke Lever** – Used in the starting of a cold engine, or in cold weather conditions. The choke enriches the fuel mixture.
7. **Air Cleaner** – Prevents dirt and other debris from entering the fuel system. Remove wing-nut on top of air filter cannister to gain access to filter element.

### NOTICE

Operating the engine without an air filter, with a damaged air filter, or a filter in need of replacement will allow dirt to enter the engine, causing rapid engine wear.

8. **Spark Plug** – Provides spark to the ignition system. Set spark plug gap to 0.6 - 0.7 mm (0.028 - 0.031 inch) for HONDA engine, and 0.5 - 0.6 mm (0.020 - 0.024 inch) for ROBIN engine. Clean spark plug once a week.
9. **Muffler** – Used to reduce noise and emissions.

### WARNING



Engine components can generate extreme heat. To prevent burns, **DO NOT** touch these areas while the engine is running or immediately after operating. **NEVER** operate the engine with the muffler removed.

10. **Fuel Tank** – Holds unleaded gasoline. For additional information refer to engine owner's manual.

## Before Starting

1. Read safety instructions at the beginning of manual.
2. Clean the compactor, removing dirt and dust. Particularly, the bottom of the plate, engine cooling air inlet, carburetor and air cleaner.
3. Check the air filter for dirt and dust. If the air filter is dirty, blow through the air filter cartridge from the inside, moving a jet of dry compressed air up and down until all dust is removed. Otherwise replace air filter with a new one.
4. Check carburetor for external dirt and dust. Clean with dry compressed air.
5. Check fastening nuts and bolts for tightness. Loosened screws or bolts due to vibration, could lead to unexpected accident.

## Engine Oil Check

1. To check the engine oil level, place the plate compactor on secure level ground with the engine stopped.
2. Remove the filler cap/dipstick from the engine oil filler hole (Figure 3) and wipe it clean.

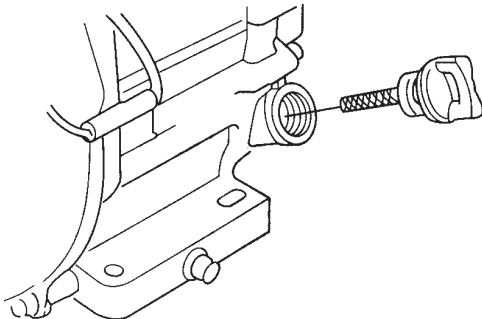

Figure 3. Engine Oil Dipstick

3. Insert and remove the dipstick without screwing it into the filler neck. Check the oil level shown on the dipstick.
4. If the oil level is low (Figure 4), fill to the edge of the oil filler hole with the recommended oil type (Table 3). Maximum oil capacity is 400 cc.

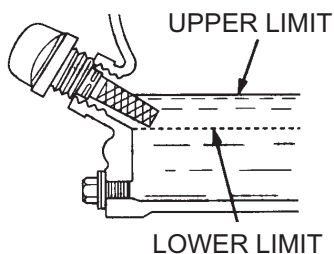

Figure 4. Engine Oil Dipstick

## NOTICE

The Oil Alert system will automatically stop the engine before the engine falls below safe limits. Always be sure to check the engine oil level prior to starting the engine.

Table 3. Oil Type

Season	Temperature	Oil Type
Summer	25°C or Higher	SAE 10W-30
Spring/Fall	25°C~10°C	SAE 10W-30/20
Winter	0°C or Lower	SAE 10W-10

## Gasoline Check

1. Remove the gasoline cap located on top of fuel tank.
2. Visually inspect to see if fuel level is low. If fuel is low, replenish with unleaded fuel.
3. When refueling, be sure to use a strainer for filtration. **DO NOT** top-off fuel. Wipe up any spilled fuel.

## Vibrator Oil Check

1. Place the MVC77 Series plate compactor horizontally on a flat surface. Make sure the compactor is level when checking the oil in the vibrator assembly.
2. Check vibrator oil level by removing the plug (vibrator oil gauge) as shown in Figure 5. The oil level should be up to the oil plug. The vibrator holds 140 cc (approximately 1 pint). **IMPORTANT**, if oil is required, replace using only SAE 10W-30 motor oil.

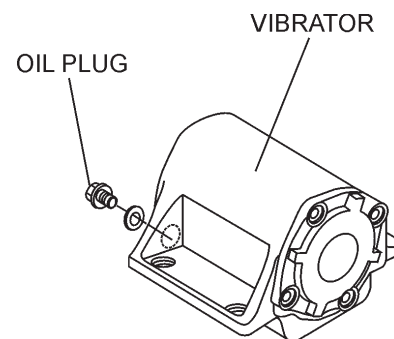

Figure 5. Vibrator Oil Plug

## V-Belt Check

### CAUTION

**NEVER** attempt to check the V-belt with the engine running. Severe injury can occur if your hand (Figure 6) gets caught between the V-belt and the clutch. Always use safety gloves.

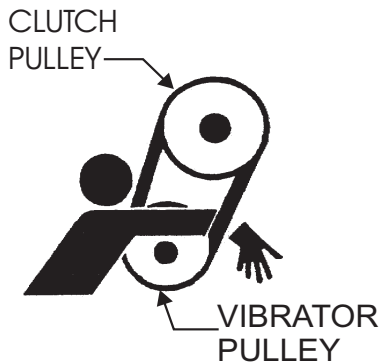

Figure 6. V-Belt Hazard

1. To check the V-belt tension, remove the three bolts that secure the belt cover to the frame as shown in Figure 7.

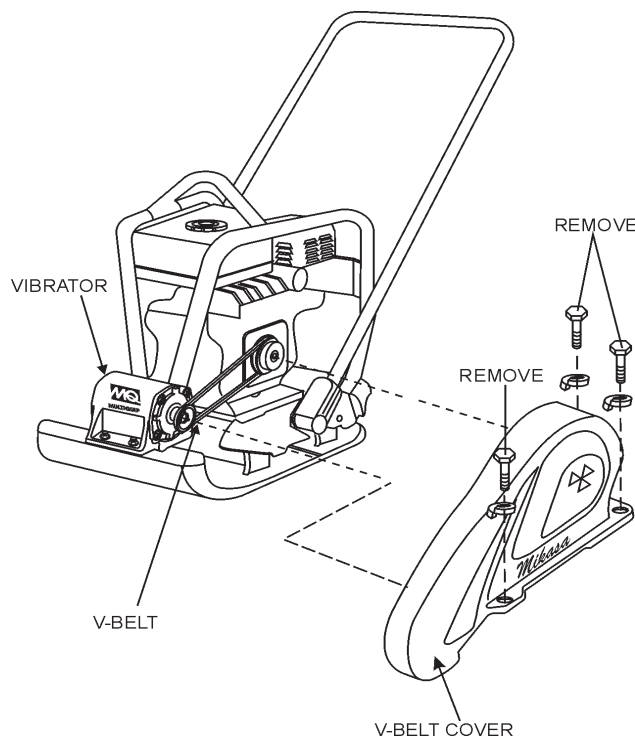

Figure 7. V-Belt Cover Removal

2. The V-belt tension is proper if the V-belt bends 10 to 15 mm (Figure 8) when depressed with finger at midway between the clutch and vibrator pulley shafts.

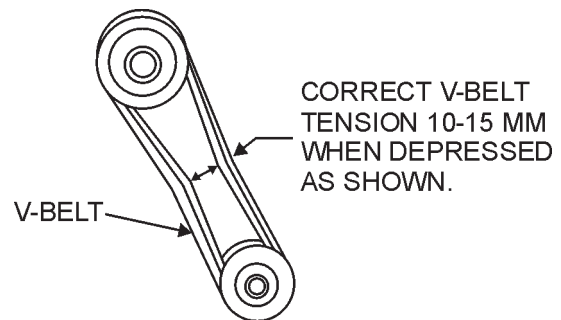

Figure 8. V-Belt Tension

3. A loose V-belt will decrease the power transmission output, causing reduced compaction and premature wear of the belt.
4. If the V-belt becomes worn or loose, replace it by using V-belt part number 070503350.

## CAUTION

**DO NOT** attempt to run the compactor until the Safety Information and Startup sections have been read.

## NOTICE

The **CLOSED** position of the choke lever enriches the fuel mixture for starting a **COLD** engine. The **OPEN** position provides the correct fuel mixture for normal operation after starting, and for restarting a warm engine.

1. Place the **fuel valve lever** (Figure 9) in the "ON" position.

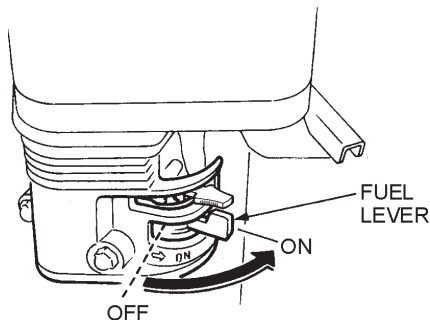

Figure 9. Fuel Valve Lever

2. Place the **Engine ON/OFF switch** (Figure 10) in the "ON" position.

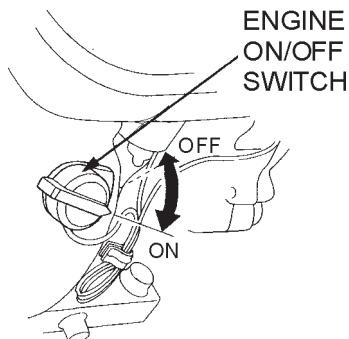

Figure 10. Engine ON/Off Switch

3. Place the **Choke Lever** (Figure 11) in the "OPEN" position.

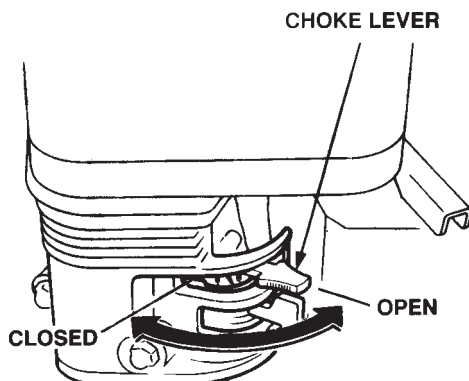

Figure 11. Choke Lever

4. Place the **throttle lever** (Figure 12) halfway between **fast** and **slow**.

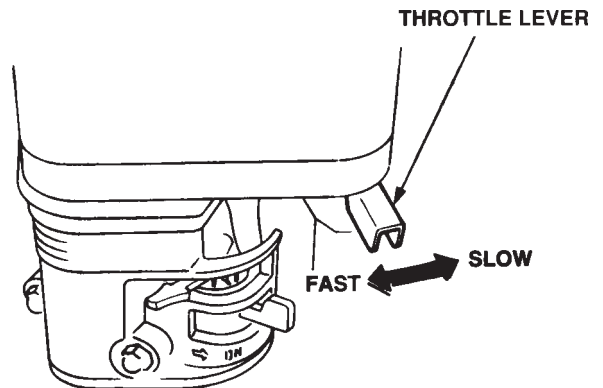

Figure 12. Throttle Lever

5. Grasp the starter grip (Figure 13) and slowly pull it out. The resistance becomes the hardest at a certain position, corresponding the compression point. Rewind the rope a little from that point and pull out sharply.

## CAUTION

**DO NOT** pull the starter rope all the way to the end.  
**DO NOT** release the starter rope after pulling. Allow it to rewind as soon as possible.

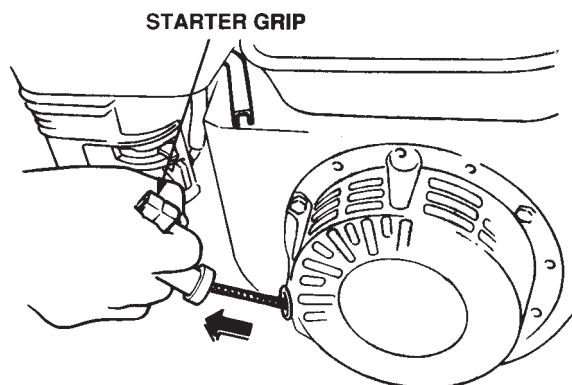

Figure 13. Starter Grip

6. If the engine has started, slowly return the choke lever (Figure 11) to the **CLOSED** position. If the engine has not started repeat steps 1 through 5.
7. Before the compactor is put into operation run the engine for 3-5 minutes.
8. Check for abnormal engine noises or fuel leaks.

## Stopping the Engine

**CAUTION**

**NEVER** stop the engine suddenly while working at high speeds.

1. Place the **throttle lever** (Figure 12) in **slow** position, and listen for the engine speed to decrease.
2. Place the **Engine ON/OFF switch** (Figure 11) in the "**OFF**" position.
3. Place the **fuel valve lever** (Figure 9) in the "**OFF**" position.

## Operation

### CAUTION

Make sure to follow all safety rules referenced in the safety section of this manual before operating compactor. Keep work area clear of debris and other objects that could cause damage to the compactor or bodily injury.

1. Once the engine has started, move the engine throttle lever quickly to the **fast** position.
2. With the throttle lever in the fast position, the engine speed should be around 2,300 RPM, therefore engaging the centrifugal clutch.

### NOTICE

Always move the throttle lever quickly without hesitation, because increasing the engine speed slowly causes the clutch to slip.

5. Firmly grasp the compactor's handle bar with both hands, the compactor will begin moving forward.
6. Slowly walk behind the compactor and be on the lookout for any large objects or foreign matter that might cause damage to the compactor or bodily injury.

7. Compactor traveling speed may drop on soils which contain clay, however there may be cases where traveling speed drops because the compaction plate does not leave the ground surface easily due to the composition of the soil. To rectify this problem do the following:

- Check the bottom plate to see if clay or equivalent material has been lodge in the plate mechanism. If so, wash with water and remove.
- Remember the compactor does not work as efficiently on clay or soils that have a high moisture content level.
- If the soil has a high moisture level, dry soil to appropriate moisture content level or carry out compaction twice.

## ⚠ CAUTION

Inspection and other services should **always** be carried out on hard and level ground with the engine shutdown.

## ⚠ CAUTION

These inspection intervals are for operation under normal conditions. Adjust your inspection intervals based on the number hours plate compactor is in use, and particular working conditions.

### Inspection and Maintenance Service Tables.

1. To make sure your plate compactor is always in good working condition before using, carry out the maintenance inspection in accordance with Tables 4 through 6.

**TABLE 4. MACHINE INSPECTION**

Item	Hours of Operation	Remarks
(Starting check)	Every 8 hours (every day)	
Loosened or lost screws	Every 8 hours (every day)	
Damage of any part	Every 8 hours (every day)	
Function of controlling system part	Every 8 hours (every day)	
Vibrator oil check	Every 100 hours	See page 19.
Vibrator oil replacement	Every 200 hours	See page 19.
V-belt (clutch) check	Every 200 hour	See page 19.

**TABLE 5. ENGINE CHECK**

(For details, see separate Engine Manual)

Item	Hours of Operation
Leakage of oil or fuel	Every 8 hours (every day)
Tightness of fastening threads	Every 8 hours (every day)
Engine oil check and replenishment	Every 8 hours (every day)(Replenish to specified max. level)
Engine oil replenishment	At first 20 hours, then every 100 hours
Air cleaner cleaning	Every 50 hours

## ⚠ CAUTION

Fuel piping and connections should be replaced every 2 years.

### Daily Service

- Check for leakage of fuel or oil.
- Remove soil and clean the bottom of compaction plate.
- Check engine oil, see page 13.
- Check for loose screws including tightness. See Table 6 below (tightening torque ), for retightening:

**TABLE 6.**

**TIGHTENING TORQUE (in. kg/cm) Diameter**

Material	6mm	8mm	10mm	12mm	14mm	16mm	18mm	20mm
4T	70	150	300	500	750	1,100	1,400	2,000
6-8T	100	250	500	800	1,300	2,000	2,700	3,800
11T	150	400	800	1,200	2,000	2,900	4,200	5,600
*	100 (6mm) 300 ~ 350 (8mm) 650 ~ 700 (10mm)							
* (In case counter-part is of aluminum)								
(Threads in use with this machine are all right handed)								
Material and quality of material is marked on each bolt, and screw.								

### Engine Oil Replacement:

1. Replace engine oil, in first 20 hours of operation and every 100 hours afterwards.
2. Oil may be drained more easily when it is warm after operation (For more details, see separate HONDA or ROBIN Owner's Manual).
3. When changing the engine oil, the old oil can be drained by removing the oil filler cap, and un-screwing the engine oil drain plug located at the base of the engine.
4. Remember to refill engine crankcase with the recommended type of oil as listed in Table 3.

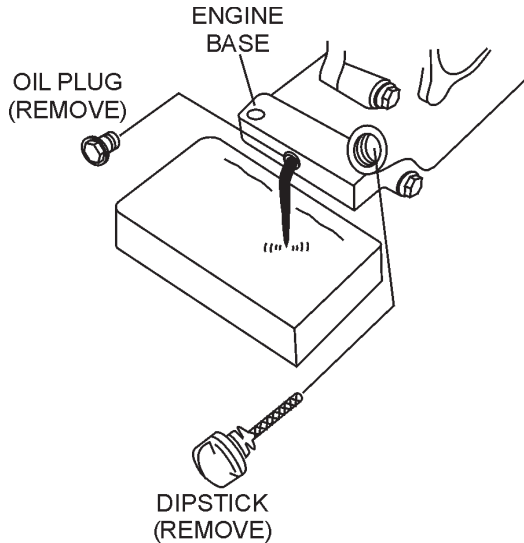

Figure 14. Engine Oil Plug

## Changing Vibrator Oil

1. When changing the vibrator oil, remove the drain plug located at the bottom- right of the vibrator (Figure 5), and simply tip the compactor to drain the oil. Note that the oil will drain more easily while it is hot. Remember to use only 10W-30 motor oil when replacing vibrator oil.

## Air Filter

1. The air filter element should be cleaned because a clogged air cleaner can cause poor engine starting, lack of power and shorten engine life substantially.
2. To clean or replace air filter loosen the wing nut on the air filter housing (Figure 15), remove the cover and take out air filter cartridge. If only cleaning of the air filter is desired blow through the air filter cartridge from the inside, moving a jet of dry compressed air up and down until all dust is removed.

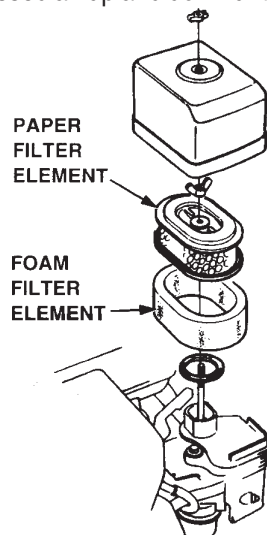

Figure 15. Air Filter

## CAUTION

**NEVER** attempt to check the V-belt with the engine running. Severe injury can occur if your hand (Figure 6) gets caught between the V-belt and the clutch. Always use safety gloves.

## Checking and Replacing the V-Belt and Clutch

1. After 200 hours of operation, remove the upper belt cover to check the V-belt tension. Tension is proper if the belt bends about 10 mm when depressed strongly with finger between shafts. Loose or worn V-belts reduces power transmission efficiency, causing weak compaction and reduces the life of the belt itself.

## CAUTION

Whenever the compactor's vibration becomes weak or lost during normal operation regardless of operation hours, check the V-belt and clutch immediately.

### ● Replacing the V-belt

Remove the upper and lower belt covers. Engage an offset wrench (13 mm) or the like to vibrator pulley (lower) fastening bolt. Engage waste cloth or the like at midway of V-belt on the left side and while pulling it back strongly, rotate the offset wrench clockwise so that the V-belt will come off.

### ● Reinstalling the V-belt

Engage V-belt to lower vibrator pulley and push the V-belt to left side of upper clutch and, in the same manner as in removal, rotate offset wrench clockwise so that the V-belt goes back on.

### ● Checking Clutch

Check the clutch simultaneously with V-belt checking. With belt removed, check outer drum of the clutch for seizure and "V" groove for wear or damage with your eyes. Clean the "V" groove as necessary. Wear of lining or shoe should be checked with running check. If the shoe is worn, power transmission becomes deficient and slipping will result.

# PREPARATION FOR LONG-TERM STORAGE

---

## Pump Storage

For storage of the pump for over 30 days, the following is required:

- Drain the fuel tank completely.
- Run the engine until the fuel in the injection system is completely consumed.
- Completely drain the oil from the engine crankcase and follow procedures described in the **HONDA** engine Owner's Manual for engine storage.
- Completely drain the compactor's hydraulic oil from the vibrating case.
- Clean entire plate compactor, especially the bottom plate removing all dirt and foreign matter.
- Cover plate compactor and engine with plastic covering or equivalent and store in a clean, dry place.

**TABLE 7. ENGINE TROUBLESHOOTING**

SYMPTON	POSSIBLE CAUSE	SOLUTION
Difficult to start, "fuel is available, but no SPARK at spark plug".	Spark plug bridging?	Check gap, insulation or replace spark plug.
	Carbon deposit on spark plug?	Clean or replace spark plug.
	Short circuit due to deficient spark plug insulation?	Check spark plug insulation, replace if worn.
	Improper spark plug gap?	Set to proper gap.
Difficult to start, "fuel is available, and SPARK is present at the spark plug".	ON/OFF switch is shorted?	Check switch wiring, replace switch.
	Ignition coil defective?	Replace ignition coil.
	Improper spark gap, points dirty?	Set correct spark gap and clean points.
	Condenser insulation worn or short circuiting?	Replace condenser.
	Spark plug wire broken or short circuiting?	Replace defective spark plug wiring.
Difficult to start, "fuel is available, spark is present and compression is normal"	Wrong fuel type?	Flush fuel system, and replace with correct type of fuel.
	Water or dust in fuel system?	Flush fuel system.
	Air cleaner dirty?	Clean or replace air cleaner.
Difficult to start, "fuel is available, spark is present and compression is low"	Suction/exhaust valve stuck or protruded?	Re-seat valves.
	Piston ring and/or cylinder worn?	Replace piston rings and or piston.
	Cylinder head and/or spark plug not tightened properly?	Torque cylinder head bolts and spark plug.
	Head gasket and/or spark plug gasket damaged?	Replace head and spark plug gaskets.
No fuel present at carburetor.	Fuel not available in fuel tank?	Fill with correct type of fuel.
	Fuel cock does not open properly?	Apply lubricant to loosen fuel cock lever, replace if necessary.
	Fuel filter clogged?	Replace fuel filter.
	Fuel tank cap breather hole clogged?	Clean or replace fuel tank cap.
	Air in fuel line?	Bleed fuel line.

**TABLE 7. ENGINE TROUBLESHOOTING (CONTINUED)**

SYMPTON	POSSIBLE CAUSE	SOLUTION
"Weak in power" compression is proper and does not misfire.	Air cleaner not clean?	Clean or replace air cleaner
	Improper level in carburetor?	Check float adjustment, re-build carburetor.
	Defective Spark plug?	Clean or replace spark plug.
	Defective Spark plug?	
"Weak in power" compression is proper but misfires.	Water in fuel system?	Flush fuel system, and replace with correct type of fuel.
	Dirty spark plug?	Clean or replace spark plug.
	Ignition coil defective?	Replace ignition coil.
Engine overheats.	Spark plug heat value improper?	Replace with correct type of spark plug.
	Correct type of fuel?	Replace with correct type of fuel
	Cooling fins dirty?	Clean cooling fins.
Rotational speed fluctuates.	Governor adjusted correctly?	Adjust governor.
	Governor spring defective?	Replace governor spring.
	Fuel flow restricted?	Check entire fuel system for leaks or clogs.
Recoil starter malfunction.	Recoil mechanism clogged with dust and dirt?	Clean recoil assembly with soap and water.
	Spiral spring loose?	Replace spiral spring.

**TABLE 8. PLATE COMPACTOR TROUBLESHOOTING**

<b>SYMPTON</b>	<b>POSSIBLE CAUSE</b>	<b>SOLUTION</b>
Travel speed too low, and vibration is weak.	Engine speed too low?	Set engine speed to correct RPM.
	Clutch slips?	Check or replace clutch.
	V-belt slips?	Adjust or replace V-belt.
	Excessive oil in vibrator?	Drain excess oil and fill to proper level.
	Malfunction in vibrator housing?	Check eccentric, gears and counter weights.
	Bearing Failure?	Replace Bearing
	Insufficient engine output?	Check engine, compression etc.

# EXPLANATION OF CODES IN REMARKS COLUMN

The following section explains the different symbols and remarks used in the Parts section of this manual. Use the help numbers found on the back page of the manual if there are any questions.

## NOTICE

The contents and part numbers listed in the parts section are subject to change **without notice**. Multiquip does not guarantee the availability of the parts listed.

## SAMPLE PARTS LIST

NO.	PART NO.	PART NAME	QTY.	REMARKS
1	12345	BOLT.....	1	INCLUDES ITEMS W/%
2%		WASHER, 1/4 IN.....		NOT SOLD SEPARATELY
2%	12347	WASHER, 3/8 IN....	1	MQ-45T ONLY
3	12348	HOSE .....		A/R ...MAKE LOCALLY
4	12349	BEARING .....	1	S/N 2345B AND ABOVE

## NO. Column

**Unique Symbols** — All items with same unique symbol

(@, #, +, %, or >) in the number column belong to the same assembly or kit, which is indicated by a note in the “Remarks” column.

**Duplicate Item Numbers** — Duplicate numbers indicate multiple part numbers, which are in effect for the same general item, such as different size saw blade guards in use or a part that has been updated on newer versions of the same machine.

## NOTICE

When ordering a part that has more than one item number listed, check the remarks column for help in determining the proper part to order.

## PART NO. Column

**Numbers Used** — Part numbers can be indicated by a number, a blank entry, or TBD.

TBD (To Be Determined) is generally used to show a part that has not been assigned a formal part number at the time of publication.

A blank entry generally indicates that the item is not sold separately or is not sold by Multiquip. Other entries will be clarified in the “Remarks” Column.

## QTY. Column

**Numbers Used** — Item quantity can be indicated by a number, a blank entry, or A/R.

A/R (As Required) is generally used for hoses or other parts that are sold in bulk and cut to length.

A blank entry generally indicates that the item is not sold separately. Other entries will be clarified in the “Remarks” Column.

## REMARKS Column

Some of the most common notes found in the “Remarks” Column are listed below. Other additional notes needed to describe the item can also be shown.

**Assembly/Kit** — All items on the parts list with the same unique symbol will be included when this item is purchased.

Indicated by:

“INCLUDES ITEMS W/(unique symbol)”

**Serial Number Break** — Used to list an effective serial number range where a particular part is used.

Indicated by:

“S/N XXXXX AND BELOW”

“S/N XXXX AND ABOVE”

“S/N XXXX TO S/N XXX”

**Specific Model Number Use** — Indicates that the part is used only with the specific model number or model number variant listed. It can also be used to show a part is NOT used on a specific model or model number variant.

Indicated by:

“XXXXX ONLY”

“NOT USED ON XXXX”

**“Make/Obtain Locally”** — Indicates that the part can be purchased at any hardware shop or made out of available items. Examples include battery cables, shims, and certain washers and nuts.

**“Not Sold Separately”** — Indicates that an item cannot be purchased as a separate item and is either part of an assembly/kit that can be purchased, or is not available for sale through Multiquip.

## SUGGESTED SPARE PARTS

---

### MVC77 Series1 TO 5 UNITS WITH HONDA GX160K1QX2 ENGINE

#### *1 to 3 Units*

Qty.	P/N	Description
3	070503350	V-BELT
1	060403060	OIL SEAL, VIBRATING
2	050101000	O-RING (FOR HANDLE)
3	9807956841	SPARK PLUG (HONDA)
1	28462ZH8003	ROPE, RECOIL STARTER (HONDA)
1	36100ZE1015	SWITCH ASSY, ENGINE STOP (HONDA)
3	17210ZE1505	ELEMENT, A/C (HONDA)
1	17620ZH7023	CAP, FUEL TANK (HONDA)
1	17672ZE2W01	FUEL FILTER, FUEL TANK (HONDA)
4	930405011	SHOCK ABSORBER

# NAMEPLATE AND DECALS

---

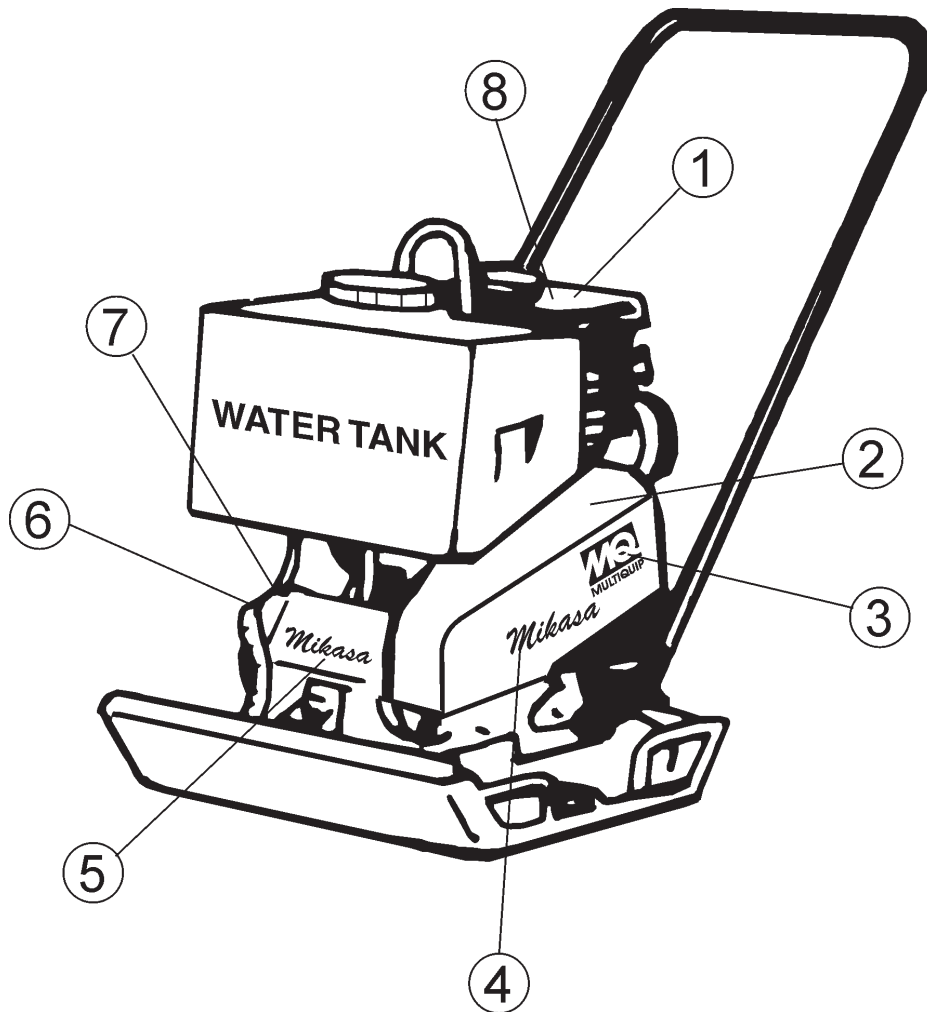

## NAMEPLATE AND DECALS

---

<u>NO</u>	<u>PART NO</u>	<u>PART NAME</u>	<u>QTY.</u>	<u>REMARKS</u>
1	920203290	DECAL: CAUTION	1	DSC01
2	920203060	DECAL: CAUTION (START ENG/VIBR)	1	NPA-306
3	920201580	DECAL: MQ LOGO	2	NPA-158
4	920106460	DECAL: MIKISA LOGO (NAME)	1	NPA-507
5	920201950	DECAL: MOTOR OIL	1	NPA-195
6		PLATE: SERIAL NO./MVC-MQ	1	CONTACT MQ SERVICE DEPT. W/MODEL & S/N
7	13118	DECAL: POWDER COATED	1	
8	920203330	DECAL: EAR PROTECTION LABEL	1	NPA-333

# MAIN BODY ASSY.

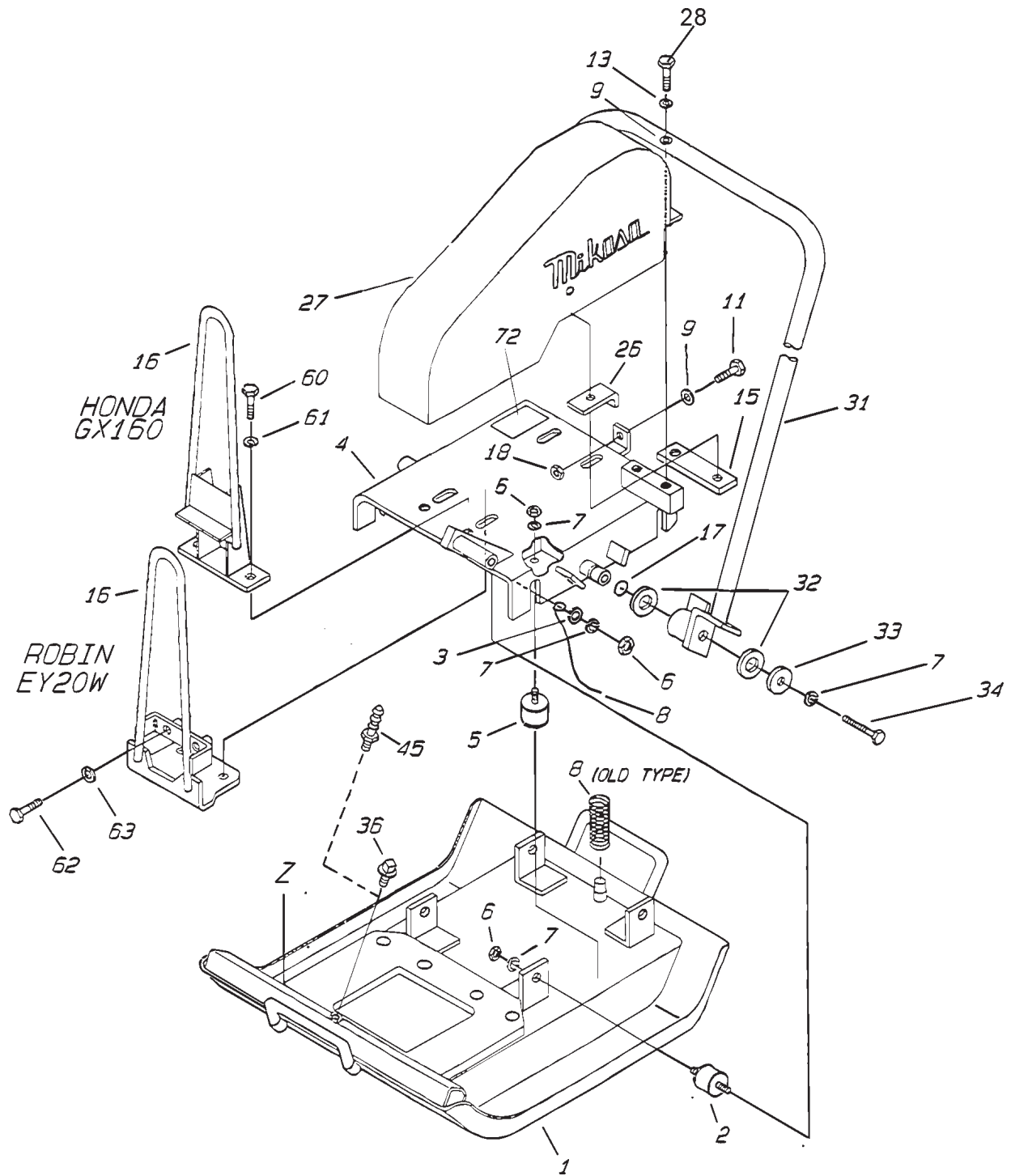

## MAIN BODY ASSY.

<u>NO</u>	<u>PART NO</u>	<u>PART NAME</u>	<u>QTY.</u>	<u>REMARKS</u>
1	408105330	VIBRATING PLATE, 430/77	1	
2	930405011	SHOCK ABSORBER MED-50/S	4	
3	031110160	PLAIN WASHER M10	4	
4	408105320	BASE .....	1	ROBIN
4	408109390	BASE .....	1	HONDA
5	939010010	SHOCK ABSORBER, STOPPER 45	1	
6	020310080	NUT M10	9	
7	030210250	SPRING WASHER M10	11	
8	959404350	SPRING .....	1	REPLACES 401010020
8	959404350	EARTH WIRE	1	
9	031108160	PLAIN WASHER M8	9	
11	011008040	BOLT 8X40 T .....	4	REPLACES 001220840
12	011208045	BOLT 8X45 T .....	1	REPLACES 001220845
13	030208200	SPRING WASHER 8M	8	
15	408420810	ENGINE NUT .....	1	ROBIN
15	408420810	ENGINE NUT .....	2	HONDA
16	408207200	HOOK .....	1	ROBIN
16	408209910	HOOK .....	1	HONDA
17	050200160	O-RING	2	
18	020108060	NUT M8, H=5	1	REPLACES 020408050
26	408404240	STOPPER	1	
27	408104800	BELT COVER	1	
28	014208020	BOLT 8X20 T .....	4	REPLACES 001220820
31	408206161	HANDLE	1	
32	952402281	WASHER 21363 (DELTRIN)	4	
33	952403450	WASHER 11X36X4.5 .....	2	REPLACES 952400220
34	0105091025	BOLT 10X25 T .....	2	REPLACES 001221025
36	408010030	PLUG 1/4	1	
45	408010080	HOSE JOINT 1/4X10D	1	
60	001221235	BOLT 12X35 T .....	2	REPLACES 001221235 HONDA
61	030212300	SW M12 .....	2	HONDA
62	011208045	BOLT 8X45 T .....	2	ROBIN
63	030208200	SPRING WASHER M8 .....	2	REPLACES 001220845 ROBIN
72	920103260	PLATE, SERIAL .....	1	CONTACT MULTIQUIP SERVICE DEPT WITH MODEL AND SERIAL NUMBER

# ENGINE PULLEY/CLUTCH ASSY.

ENGINE PULLEY/CLUTCH ASSY.

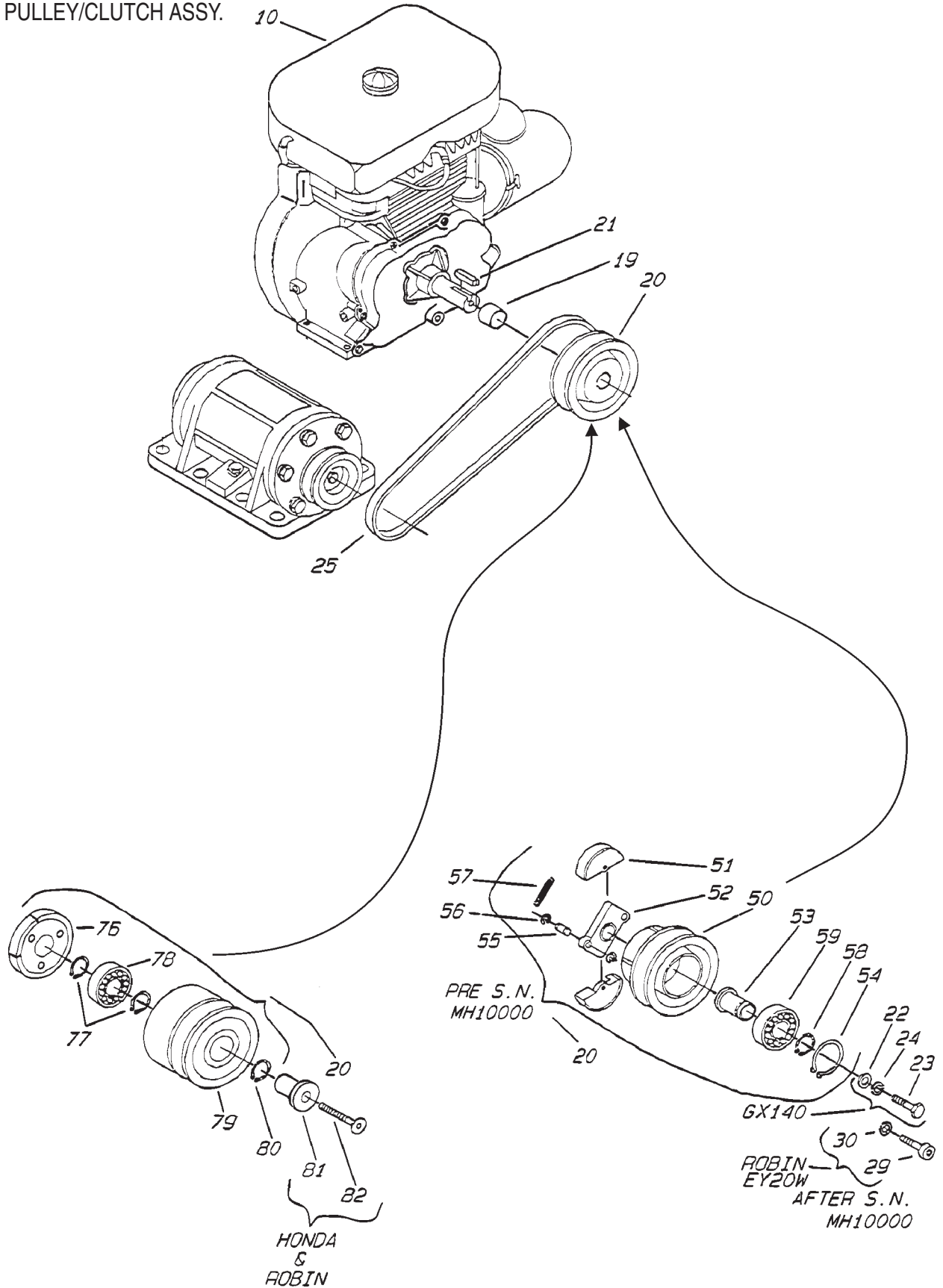

## ENGINE PULLEY/CLUTCH ASSY.

### ENGINE PULLEY/CLUTCH ASSY.

<u>NO</u>	<u>PART NO</u>	<u>PART NAME</u>	<u>QTY.</u>	<u>REMARKS</u>
10	EH172YD4020	ENGINE ASSY. (ROBIN) .....	1 .....	REPLACES 911202046
10		ENGINE ASSY. (HONDA) .....	1 .....	GX140Q1B5 NO LONGER AVAILABLE
10	GX160K1QX2	ENGINE ASSY. (HONDA) .....	1 .....	REPLACES 912216002
19	408420830	CLUTCH SPACER .....	1 .....	ROBIN
19	408434570	SPACER 20X25X8.4/77H .....	1 .....	HONDA
20	408910020	CLUTCH ASSY .....	1 .....	REPLACES 16053
21	408412320	KEY 4.78X4.78X20 .....	1 .....	
22	952403630	WASHER 9X30X3 .....	1 .....	HONDA
23	009110003	BOLT 5/16-24 UNF-35MM (HONDA) .....	1 .....	REPLACES 402010150
23	404010060	BOLT 5/16-24UNF-20MM .....	1 .....	HONDA
24	030208200	SPRING WASHER M8 .....	1 .....	HONDA
25	070503350	V-BELT ( 3VX-335) .....	1 .....	
29	408010060	SOCKET HEAD BOLT 3/8X32 .....	1 .....	ROBIN
30	031110160	WASHER 11253 .....	1 .....	REPLACES 952401440 (ROBIN)
50	943010010	PULLEY DRUM .....	1 .....	
51	943020010	CLUTCH SHOE .....	2 .....	
52	943050010	CLUTCH BOSS/D; 19.05 .....	1 .....	
53	943040010	BEARING COLLAR/D; 19.05 .....	1 .....	
54	JISB2804C25	STOP RING .....	1 .....	REPLACES 080200250
55	943050020	ARM PIN .....	2 .....	
56	080300090	STOP RING .....	4 .....	
57	943030010	CLUTCH SPRING .....	2 .....	
58	080100520	STOP RING .....	1 .....	
59	046006250	BEARING (6205 DDU) .....	1 .....	REPLACES 046006250
76	408910020	CLUTCH ROTOR .....	1 .....	REPLACES 16093
78	16095	BEARING 1.1/8" ID X 2.1/8" OD .....	1 .....	
79	408910020	DRUM 4.5/8" (INCLUDES ITEMS 77 & 78) .....	1 .....	REPLACES 16096
80	EM926029	RETAINING RING 1.1/8" DIA .....	1 .....	
81	16086	CLUTCH RETAINER .....	1 .....	
82	2638	FHSC CAP SCREW 5/16-24 X1 .....	1 .....	

# VIBRATOR/PLATE MOUNTING ASSY.

---

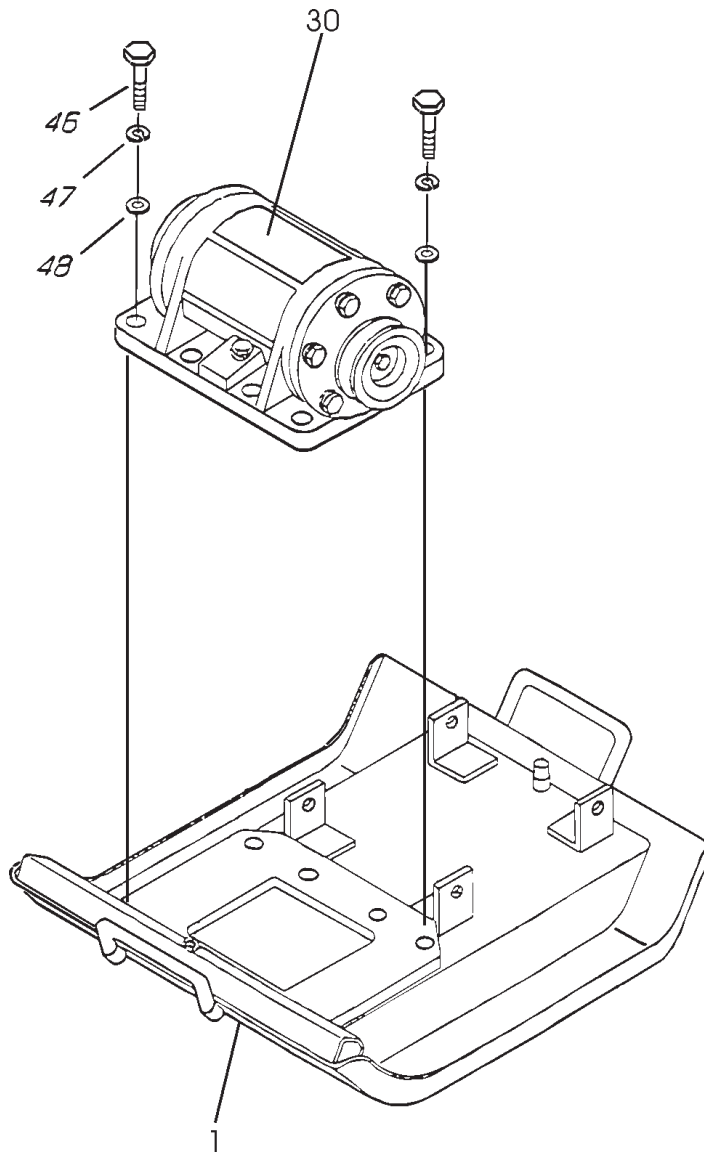

## VIBRATOR/PLATE MOUNTING ASSY.

---

<u>NO</u>	<u>PART NO</u>	<u>PART NAME</u>	<u>QTY.</u>	<u>REMARKS</u>
1	408105330	VIBRATING PLATE	1	
46	012212035	BOLT 12X35 T .....	9 .....	REPLACES 001221235
47	030212300	SPRING WASHER M12	9	
48	031112230	PLAIN WASHER M12	9	
30	408910010	VIBRATOR ASSY. ....	1 .....	SEE PAGES 36 AND 37

**VIBRATOR ASSY.**

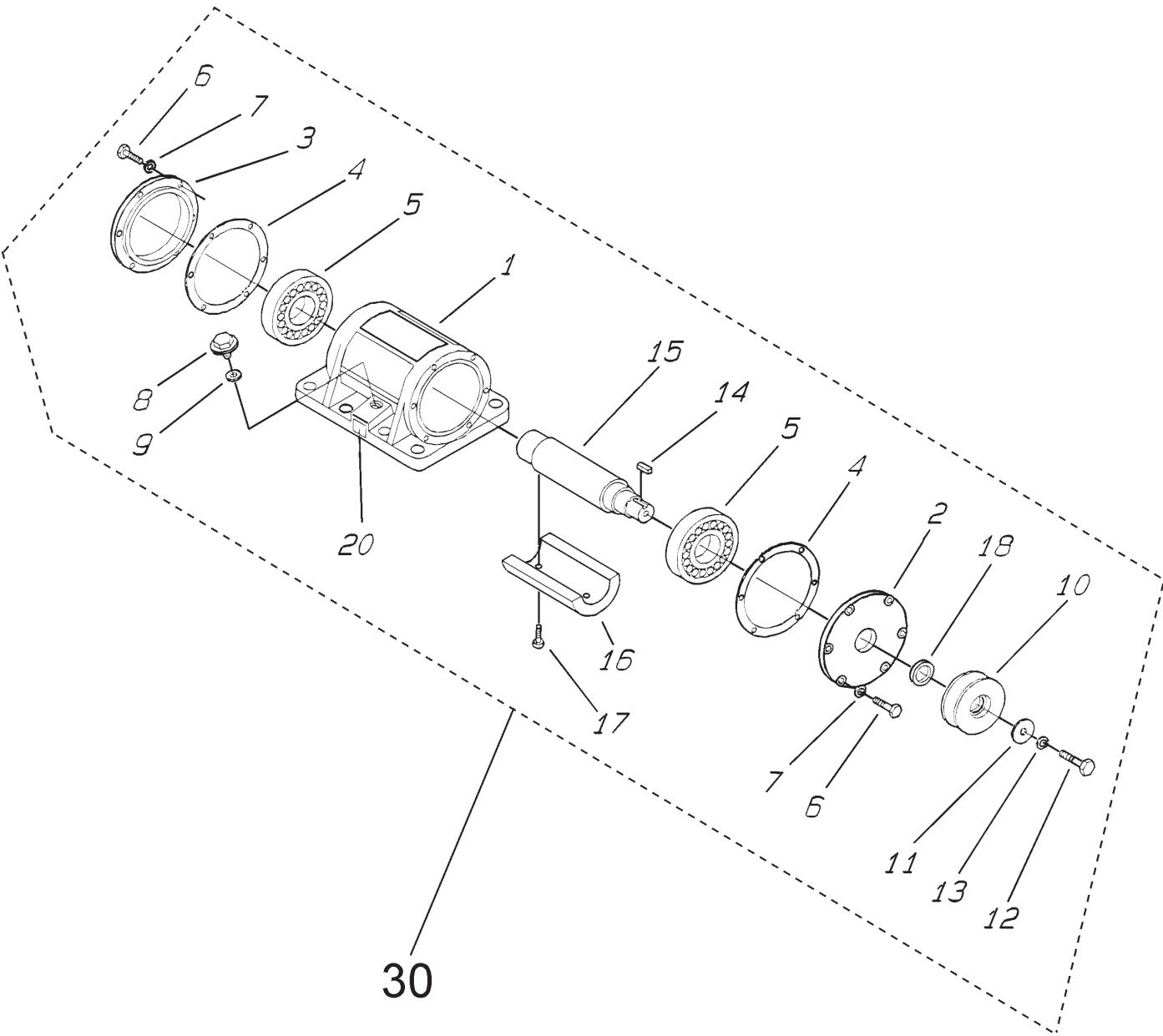

## VIBRATOR ASSY.

---

<u>NO</u>	<u>PART NO</u>	<u>PART NAME</u>	<u>QTY.</u>	<u>REMARKS</u>
1*	408010057	VIBRATING CASE/77,90 .....	1 .....	REPLACES 408010050
2*	401301260	CASE COVER/A	1	
3*	401301270	CASE COVER/B	1	
4*	401010190	PACKING	2	
5*	040406309	BEARING	2	
6*	011208025	BOLT 8 X 25 T .....	12 .....	REPLACES 001220825
7*	030208200	SPRING WASHER	12	
8*	953400270	PLUG 1/4 X 14	1	
9*	953405260	PACKING 1/4 .....	1 .....	REPLACES 953400160
10*	408420840	PULLEY VIBRATOR	1	
11*	401010220	WASHER 13406	1	
12*	001221235	BOLT 12 X 35 T .....	1 .....	REPLACES 001221235
13*	030212300	SPRING WASHER M12	1	
14*	951010090	KEY 7 X7 X 23	1	
15*	401010200	ROTATOR SHAFT	1	
16*	401010240	ECCENTRIC ROTATOR	1	
17*	014212030	SOCKET HEAD BOLT 12 X 30 .....	2 .....	REPLACES 001521230
18*	060203030	OIL SEAL TC-35488 .....	1 .....	REPLACES 060403060
20*	920101190	DECAL, TURBINE OIL NP -119	1	
30	408910010	VIBRATOR ASSY. ....	1 .....	INCLUDES ITEMS W/*

**WATER TANK ASSY.**

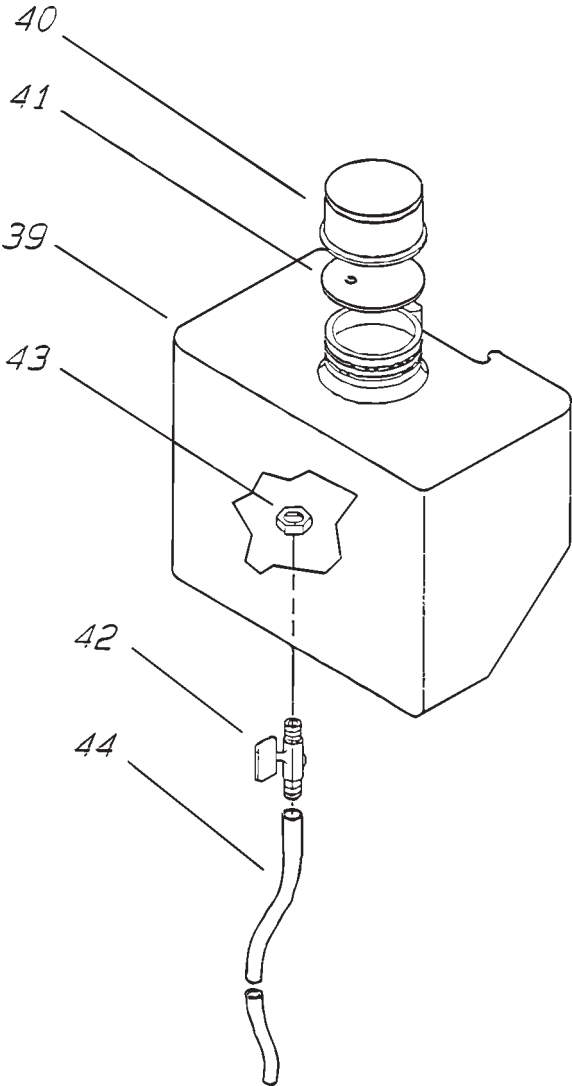

# WATER TANK ASSY.

---

<u>NO</u>	<u>PART NO</u>	<u>PART NAME</u>	<u>QTY.</u>	<u>REMARKS</u>
39	408106380	WATER TANK	1	
40	408316691	CAP, WATER TANK (W/PK) .....	1 .....	REPLACES 408316690
41	408424691	PACKING, 115D-2T	1	
42	954403240	COCK PT 1/4, BH-1211	1	
43	959403790	NUT PS-1/4	1	
44	402010060	VINYL PIPE 9.5X14X450L .....	1 .....	REPLACES 408424840

# HONDA GX160K1QX2 — CYLINDER ASSY.

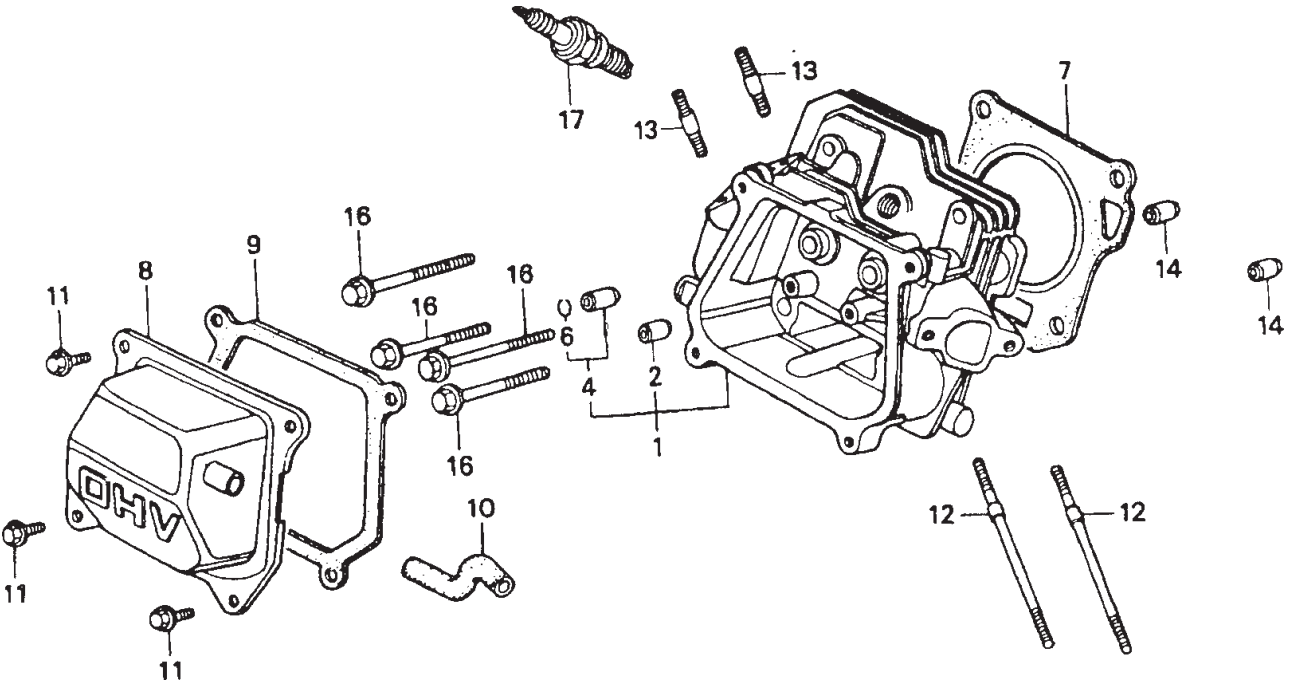

## HONDA GX160K1QX2 — CYLINDER ASSY.

---

<u>NO</u>	<u>PART NO</u>	<u>PART NAME</u>	<u>QTY.</u>	<u>REMARKS</u>
1	12210ZH8000	HEAD COMP., CYLINDER	1	
2	12204ZE01306	GUIDE, INLET VALVE	1	
4	12205ZE1315	GUIDE, EXHAUST VALVE	1	
6	12216ZE5300	CLIP, VLAVE GUIDE	1	
7	12251ZF1800	GASKET, CYLINDER HEAD	1	
8	12310ZE1010	COVER COMP., HEAD	1	
9	12391ZE1000	PACKING, HEAD COVER	1	
10	15721ZH8000	TUBE, BREATHER	1	
11	90013883000	FLANGE BOLT 6X12	4	
12	90043ZE1020	STUD BOLT 6X112	2	
13	90047ZE1000	STUD BOLT 8X32	2	
14	9430110160	KNOCK PIN 10X16	2	
16	957230806000	FLANGE BOLT 8X60	4	
17	9807956841	SPARK PLUG BP6ES NGK	1	
17	9807956854	SPARK PLUG W20EP-U DENSO	1	

# HONDA GX160K1QX2 — CYLINDER BARREL ASSY.

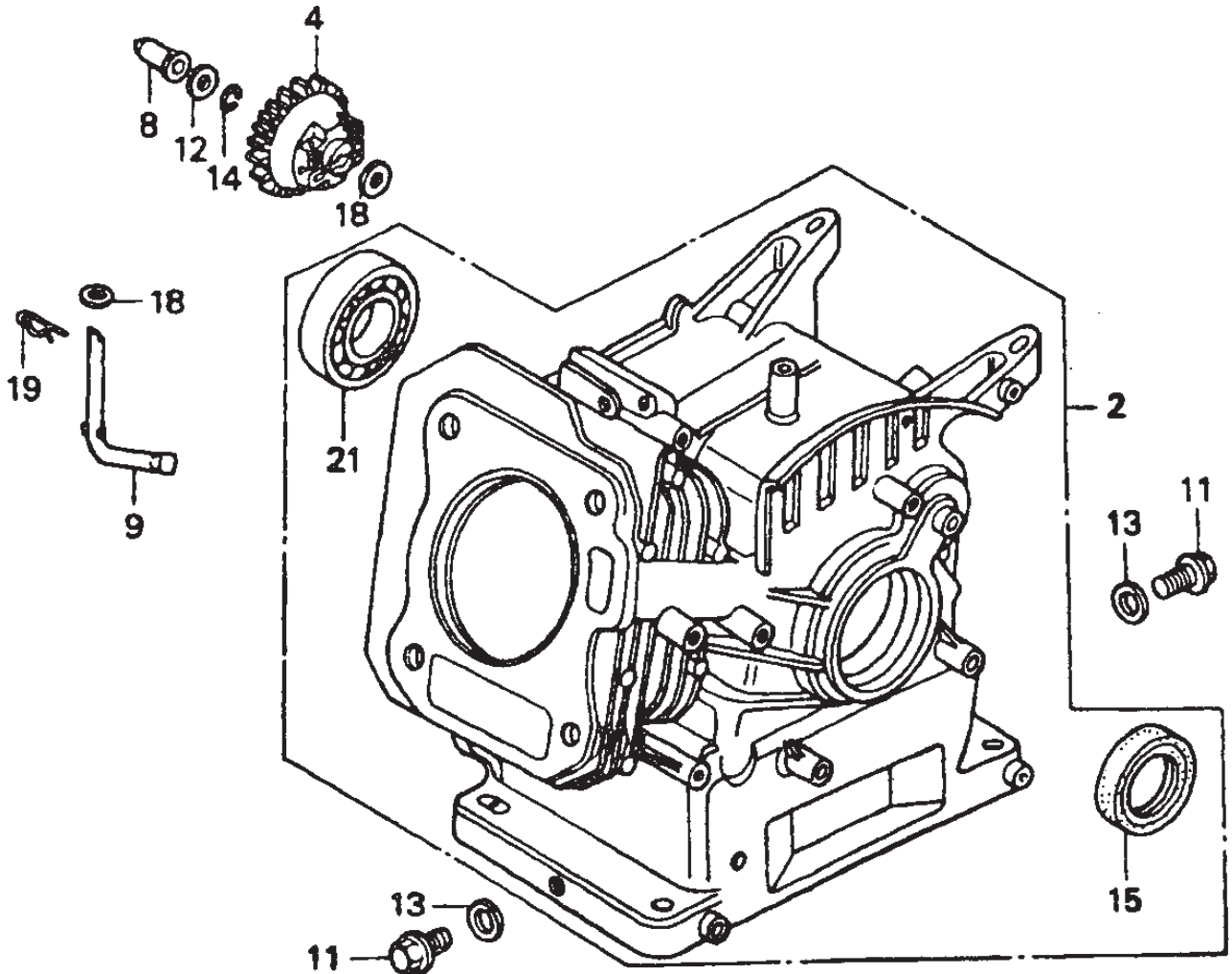

## HONDA GX160K1QX2 — CYLINDER BARREL ASSY.

---

<u>NO</u>	<u>PART NO</u>	<u>PART NAME</u>	<u>QTY.</u>	<u>REMARKS</u>
2	12000ZH8010	BARREL ASSY. CYLINDER .....	1 .....	INCLUDES ITEMS W/*
4	16510ZE1000	GOVERNOR ASSY.	1	
8	16531ZE1000	SLIDER, GOVERNOR	1	
9	16541ZE1000	SHAFT, GOVERNOR ARM	1	
11	90131ZE1000	BOLT, DRAIN PLUG	2	
12	90451ZE1000	THRUST WASHER 6MM	1	
13	90601ZE1000	WASHER, DRAIN PLUG	2	
14	90602ZE1000	CLIP, GOVERNOR HOLDER	1	
15*	91202883005	OIL SEAL 25X41X6	1	
18	9410106800	PLAIN WASHER 6MM	2	
19	9425108000	LOCK PIN 8MM	1	
21*	91001ZF1003	BALL BEARING 6205TMB	1	

# HONDA GX160K1QX2 — CRANKCASE COVER ASSY.

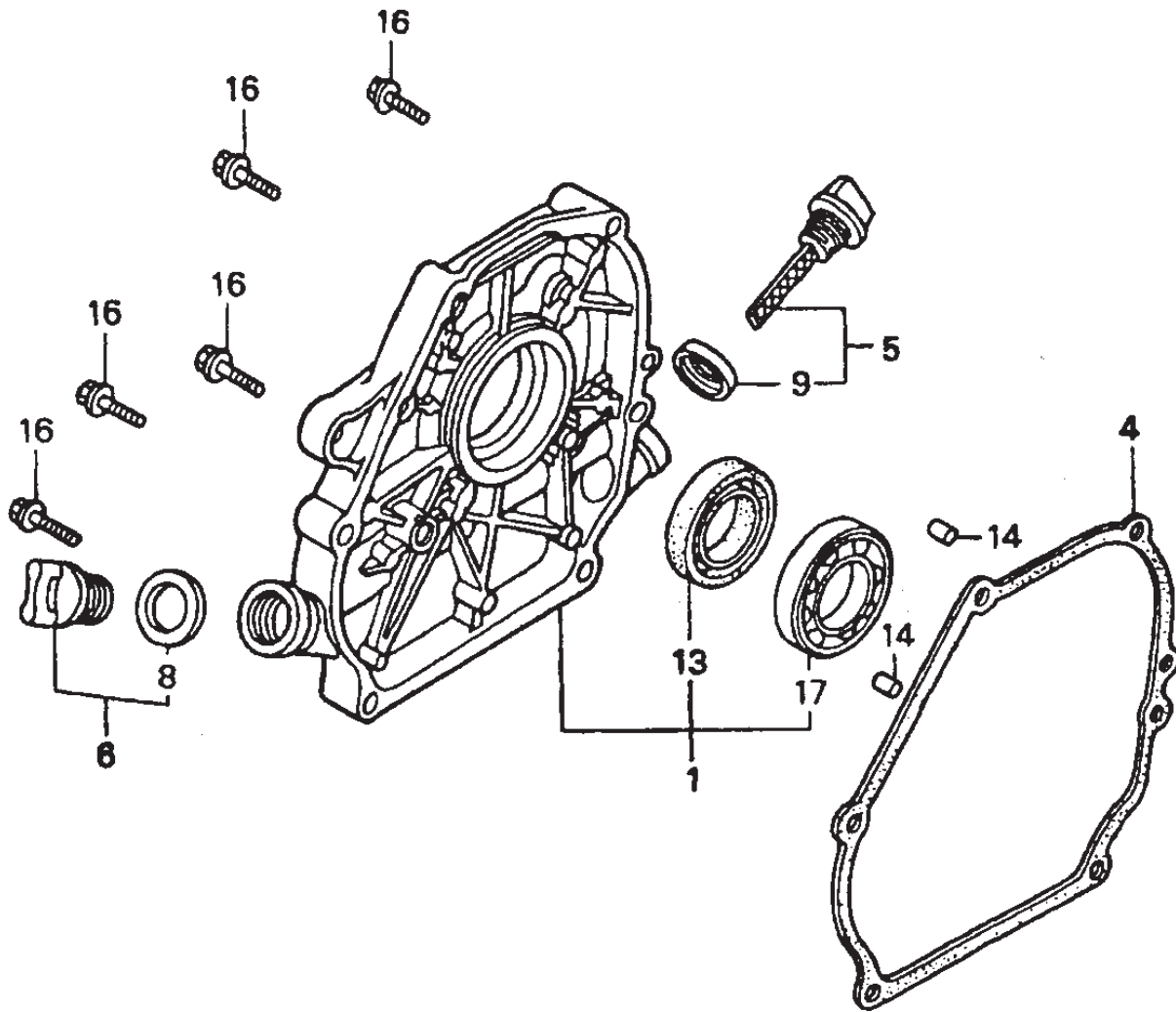

## HONDA GX160K1QX2 — CRANKCASE COVER ASSY.

---

<u>NO</u>	<u>PART NO</u>	<u>PART NAME</u>	<u>QTY.</u>	<u>REMARKS</u>
1	11300ZZE1633	COVER ASSY. CRANKCASE .....	1 .....	INCLUDES ITEMS W/*
4	11381ZH8801	GASKET CRANKCASE	1	
5	15600ZE1003	OIL GAUGE ASSY. ....	1 .....	INCLUDES ITEMS W/%
6	15600ZG4003	OIL PLUG ASSY. ....	1 .....	INCLUDES ITEMS W/#
8#	15625ZE1003	PACKING, OIL FILLER CAP	1	
9%	15625ZE1003	PACKING, OIL FILLER CAP	1	
13*	91202883005	OIL SEAL 25X41X6	1	
14	9430108140	KNOCK PIN 8X14	2	
16	957010803200	FLANGE BOLT 8X32	6	
17*	961006205000	BALL BEARING 6205	1	

**HONDA GX160K1QX2 — CRANKSHAFT ASSY.**

---

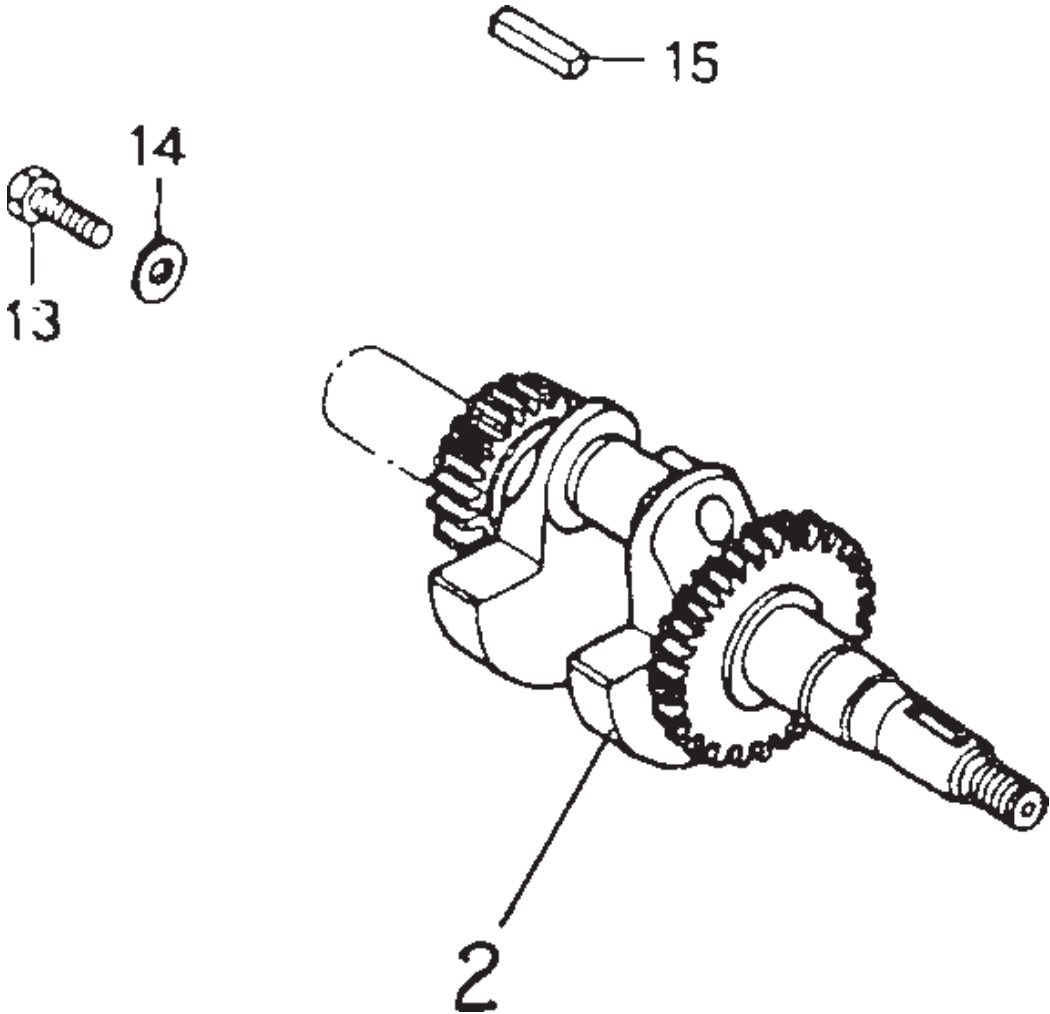

## HONDA GX160K1QX2 — CRANKSHAFT ASSY.

---

<u>NO</u>	<u>PART NO</u>	<u>PART NAME</u>	<u>QTY.</u>	<u>REMARKS</u>
2	13310ZE1000	CRANKSHAFT COMP.	1	
13	92101080250A	BOLT	1	
14	90473842000	WASHER 8MM	1	
15	90741883810	KEY 5X5X33	1	

# HONDA GX160K1QX2 — PISTON ASSY.

PISTON ASSY.

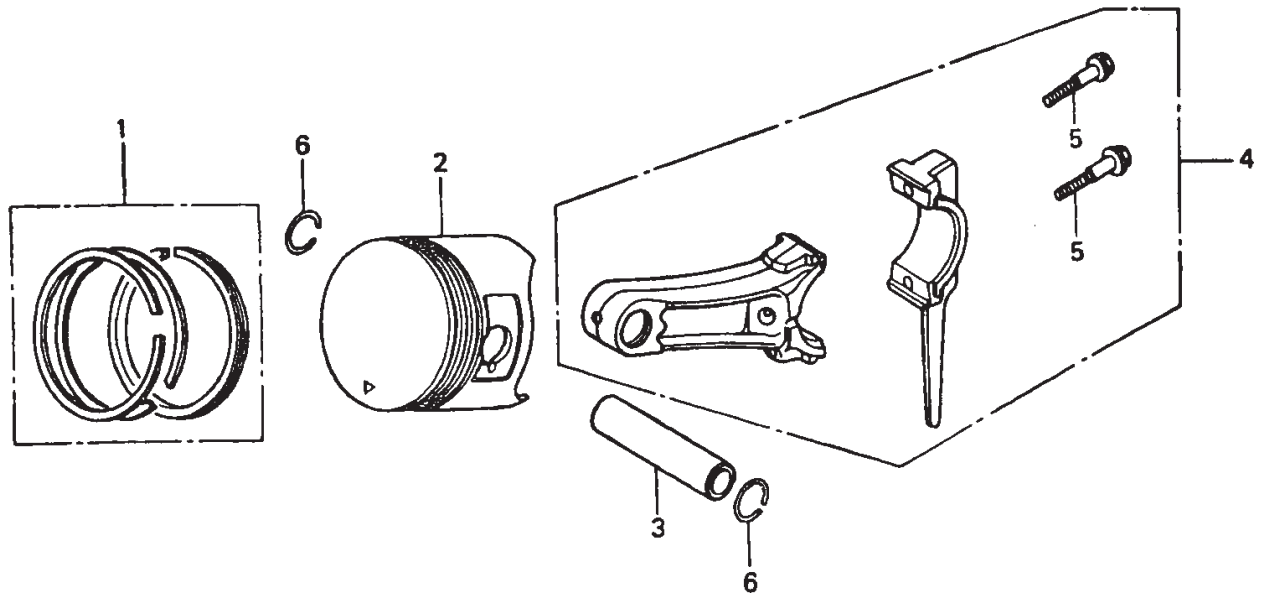

## HONDA GX160K1QX2 — PISTON ASSY.

---

### PISTON ASSY.

<u>NO</u>	<u>PART NO</u>	<u>PART NAME</u>	<u>QTY.</u>	<u>REMARKS</u>
1	13010ZH8941	RING SET, PISTON (STD)	1	
1	13011ZH8941	RING SET, PISTON (0.25)	1	
1	13012ZH8941	RING SET, PISTON (0.50)	1	
1	13013ZH8941	RING SET, PISTON (0.75)	1	
2	13101ZH8000	PISTON (STD)	1	
2	13102ZH8000	PISTON (0.25)	1	
2	13103ZH8000	PISTON (0.50)	1	
2	13104ZH8000	PISTON (0.75)	1	
3	13111ZE1000	PISTON PIN	1	
4	13200ZE1010	CONNECTING ROD ASSY. ....	1	..... INCLUDES ITEMS W/#
5#	90001ZE1000	CONNECTING ROD BOLT	2	
6	90551ZE1000	CLIP, PISTON PIN 18MM	2	

# HONDA GX160K1QX2 — CAMSHAFT ASSY.

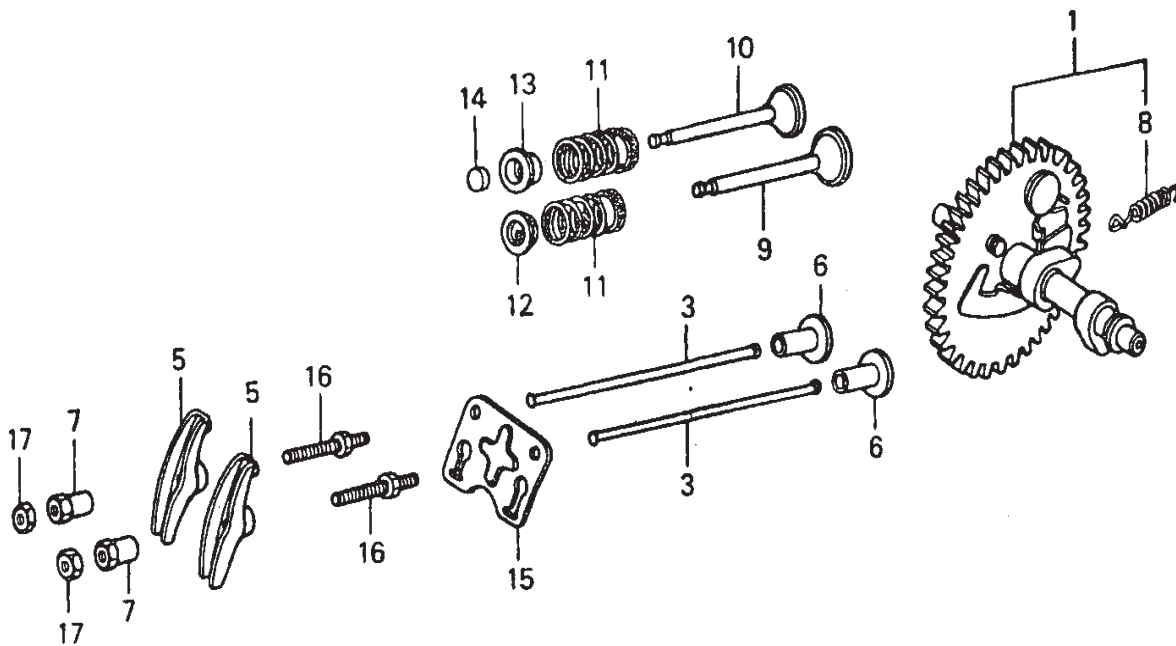

## HONDA GX160K1QX2 — CAMSHAFT ASSY.

---

<u>NO</u>	<u>PART NO</u>	<u>PART NAME</u>	<u>QTY.</u>	<u>REMARKS</u>
1	14100ZE1812	CAMSHAFT ASSY. ....	1	INCLUDES ITEMS W/#
3	14410ZE1010	PUSH ROD	2	
5	14431ZE1000	ARM, VALVE ROCKER	2	
6	14441ZE1010	VALVE LIFTER	2	
7	14451ZE1013	PIBOT, ROCKER ARM	2	
8#	14568ZE1000	SPRING, WEIGHT RETURN	1	
9	14711ZF1000	INLET VALVE	1	
10	14721ZF1000	EXHAUST VALVE	2	
11	14751ZF1000	SPRING, VALVE	1	
12	14771ZE1000	RETAINER, INTAKET VALVE	1	
13	14773ZE1000	RETAINER, EXHAUST VALVE	1	
14	14781ZE1000	ROTATOR, VALVE	1	
15	14791ZE1010	PLATE, PUSH ROD GUIDE	1	
16	90012ZE0010	PIBOT BOLT 8MM	2	
17	90206ZE1000	NUT, PIBOT ADJUSTING	2	

# HONDA GX160K1QX2 — RECOIL STARTER ASSY.

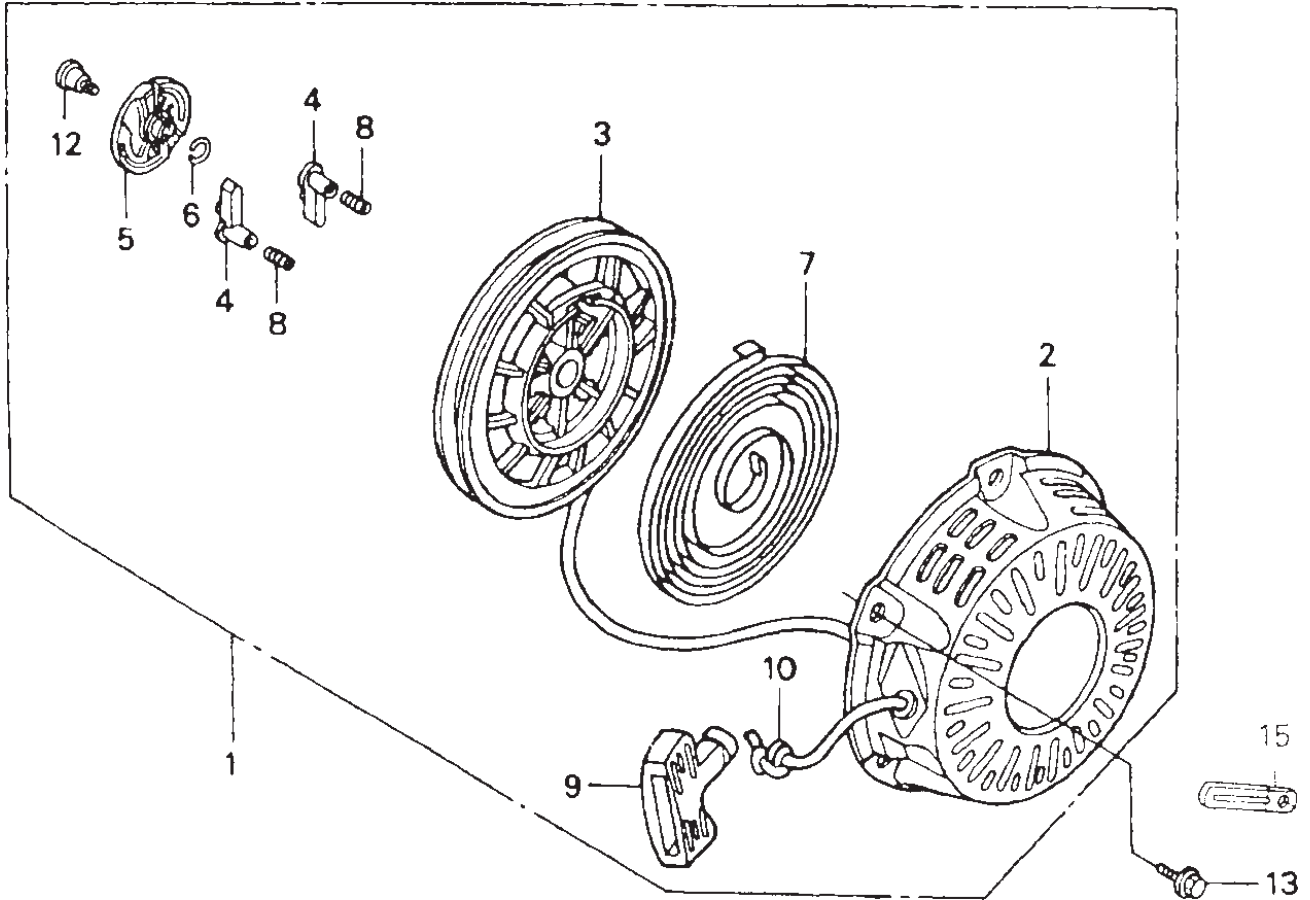

## HONDA GX160K1QX2 — RECOIL STARTER ASSY.

---

<u>NO</u>	<u>PART NO</u>	<u>PART NAME</u>	<u>QTY.</u>	<u>REMARKS</u>
1	28400ZH8013ZA	RECOIL STARTER*NH1* (RED) .....	1 .....	INCLUDES ITEMS W/#
1	28400ZH8013ZB	RECOIL STARTER*NH1* (BLACK) .	1 .....	INCLUDES ITEMS W/#
2#	28410ZH8003ZA	CASE COMP., STARTER	1	
3#	28420ZH8013	REEL RECOIL STARTER	1	
4#	28422ZH8013	RACHET STARTER	2	
5#	28433ZH8003	RACHET GUIDE	1	
6#	28441ZH8003	FRICTION SPRING	1	
7#	28442ZH8003	SPRING, RECOIL STARTER	1	
8#	28443ZH8003	SPRING, RETURN	2	
9#	28461ZH8003	STARTER KNOB	1	
10#	28462ZH8003	ROPE, RECOIL STARTER	1	
12#	90003ZH8003	SET SCREW	1	
13	957010600800	FLANGE BOLT 6X8	3	
15	32901MA1000	CLIP, CORD	1	

# HONDA GX160K1QX2 — FAN COVER ASSY.

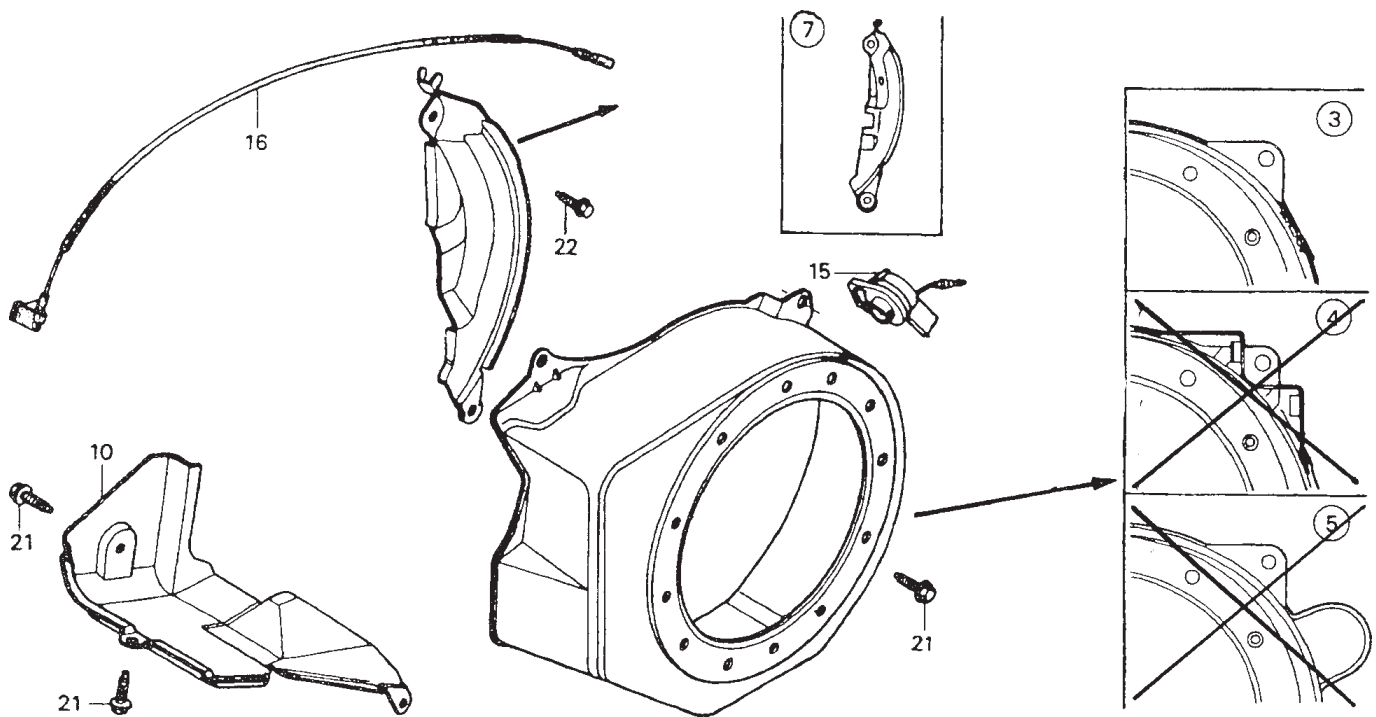

## HONDA GX160K1QX2 — FAN COVER ASSY.

---

<u>NO</u>	<u>PART NO</u>	<u>PART NAME</u>	<u>QTY.</u>	<u>REMARKS</u>
3	19610ZE1000ZA	FAN COVER COMP.	1	
7	19612ZH8000	SIDE PLATE (STD)	1	
10	19630ZH8000	SHROUD COMP.	1	
15	36100ZE1015	SWITCH ASSY. ENGINE STOP	1	
16	36101ZE1010	CORD, STOP SWITCH 370MM	1	
21	90013883000	FLANGE BOLT 6X12	6	
22	90022888010	FLANGE BOLT 6X20	1	

**HONDA GX160K1QX2 — CARBURETOR ASSY.**

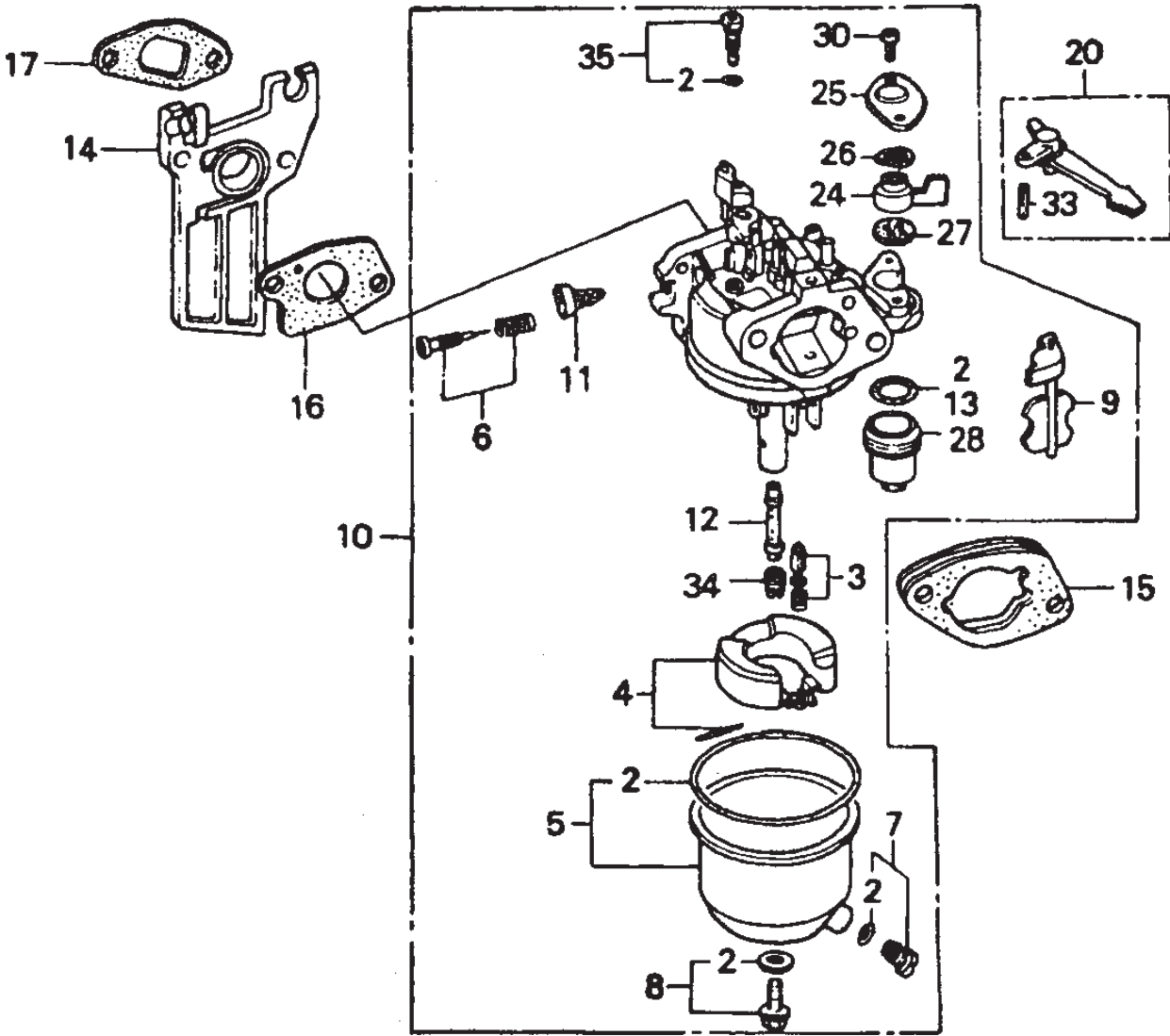

## HONDA GX160K1QX2 — CARBURETOR ASSY.

<b>NO</b>	<b>PART NO</b>	<b>PART NAME</b>	<b>QTY.</b>	<b>REMARKS</b>
2#	16010ZE1812	GASKET SET	1	
3#	16011ZE0005	FLOAT VALVE SET	1	
4#	16013ZE0005	FLOAT SET	1	
5#	16015ZE0831	FLOAT CHAMBER SET .....	1	INCLUDES O' RING
6#	16016ZE0005	PILOT SCREW	1	
7#	16024ZE1811	DRAIN SCREW SET .....	1	INCLUDES GASKET
8#	16028ZE0005	SCREW SET .....	1	INCLUDES GASKET
9#	16044ZE0005	CHOKE SET	1	
10	16100ZH8822	CARBURETOR ASSY. ....	1	INCLUDES ITEMS W/#
11#	16124ZE0005	SCREW, THROTTLE STOP	1	
12#	16166ZH8W50	MAIN NOXXLE	1	
13#	16173001004	PACKING, CUP	1	
14	16211ZE1000	INSULATOR, CARBURETOR	1	
15	16220ZE1020	SPACER COMP., CARBURETOR	1	
16	16221ZH8801	PACKING, CARBURETOR	1	
17	16212ZH8800	PACKING, INSULATOR	1	
20	16610XE1000	CHOKE LEVER COMP. ....	1	INCLUDES ITEM W/*
24#	16953ZE1812	LEVER, COCK	1	
25#	16954ZE1812	PLATE, LEVER SETTING	1	
26#	16956ZE1811	SPRING, COCK LEVER	1	
27#	16957ZE1812	PACKING, FUEL COCK	1	
28#	16967ZE0811	CUP, FUEL STRAINER	1	
30#	93500030061H	SCREW 3X6	2	
33*	9430520122	SPRING PIN 2X12	1	
34#	99101ZH80700	MAIN JET #70	1	
35#	99204ZE00350	PILOTT JET SET #35 .....	1	INCLUDES GASKET

# HONDA GX160K1QX2 — AIR CLEANER ASSY.

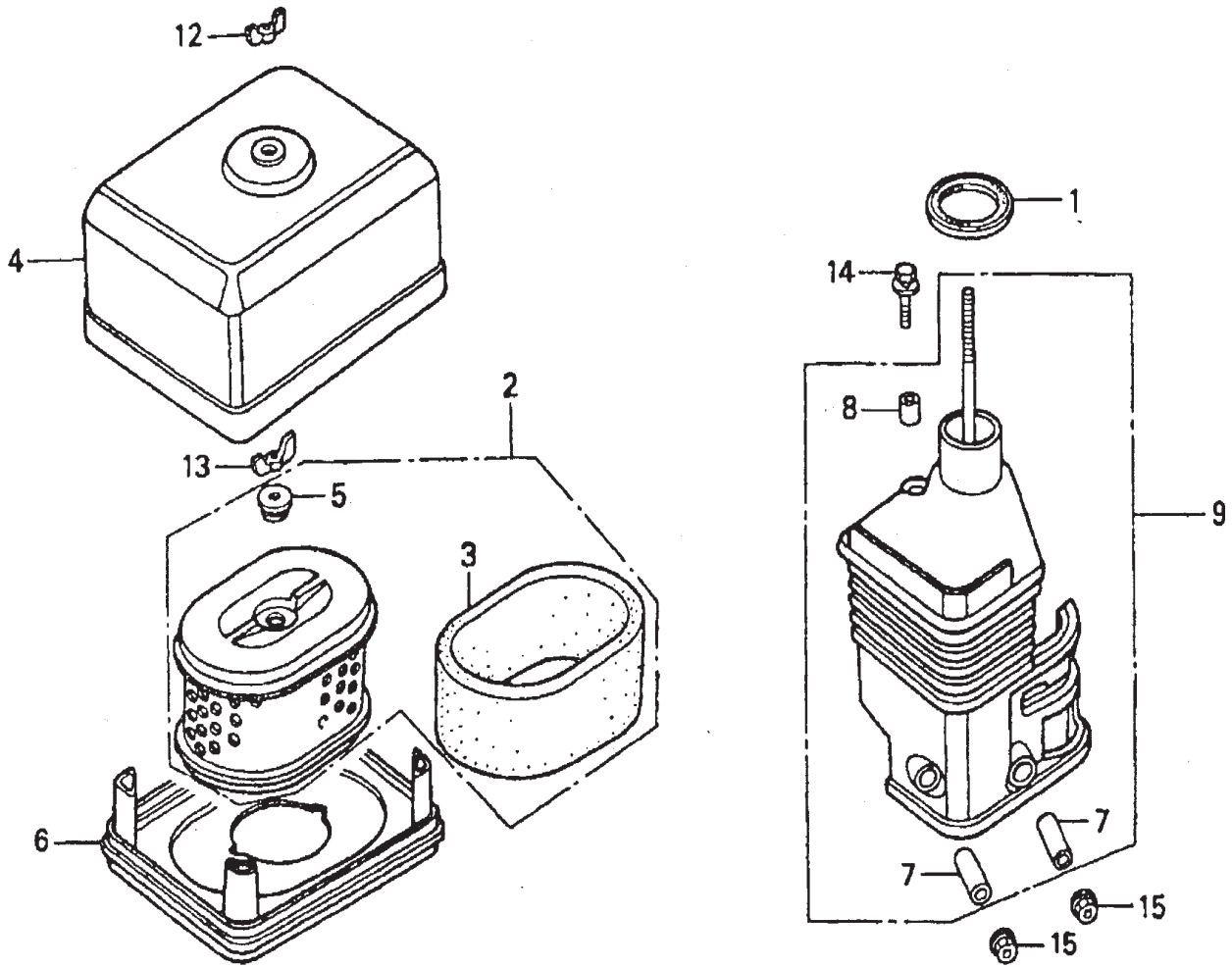

## HONDA GX160K1QX2 — AIR CLEANER ASSY.

---

<u>NO</u>	<u>PART NO</u>	<u>PART NAME</u>	<u>QTY.</u>	<u>REMARKS</u>
1	16271ZE1000	PACKING, ELBOW	1	
2	17210ZE1822	CLEANER ELEMENT .....	1 .....	INCLUDES ITEMS W/*
3*	17218ZE1821	OUTER ELEMENT	1	
4	17230ZE1820	COVER, AIR CLEANER	1	
5*	17232891000	GROMET, AIR CLEANER	1	
6	17235ZE1831	NOSE, SILENCER	1	
7%	17238ZE7010	COLLAR, AIR CLEANER	2	
8%	17239ZE1000	COLLAR (B), AIR CLEANER	1	
9	17410ZE1020	ELBOW COMP., AIR CLEANER ...	1 .....	INCLUDES ITEMS W/%
12	90325044000	NUT	1	
13	90325044000	NUT	1	
14	957010602000	FLANGE BOLT 6X20	1	
15	9405006000	FLANGE BOLT 6MM	2	

# HONDA GX160K1QX2 — MUFFLER ASSY.

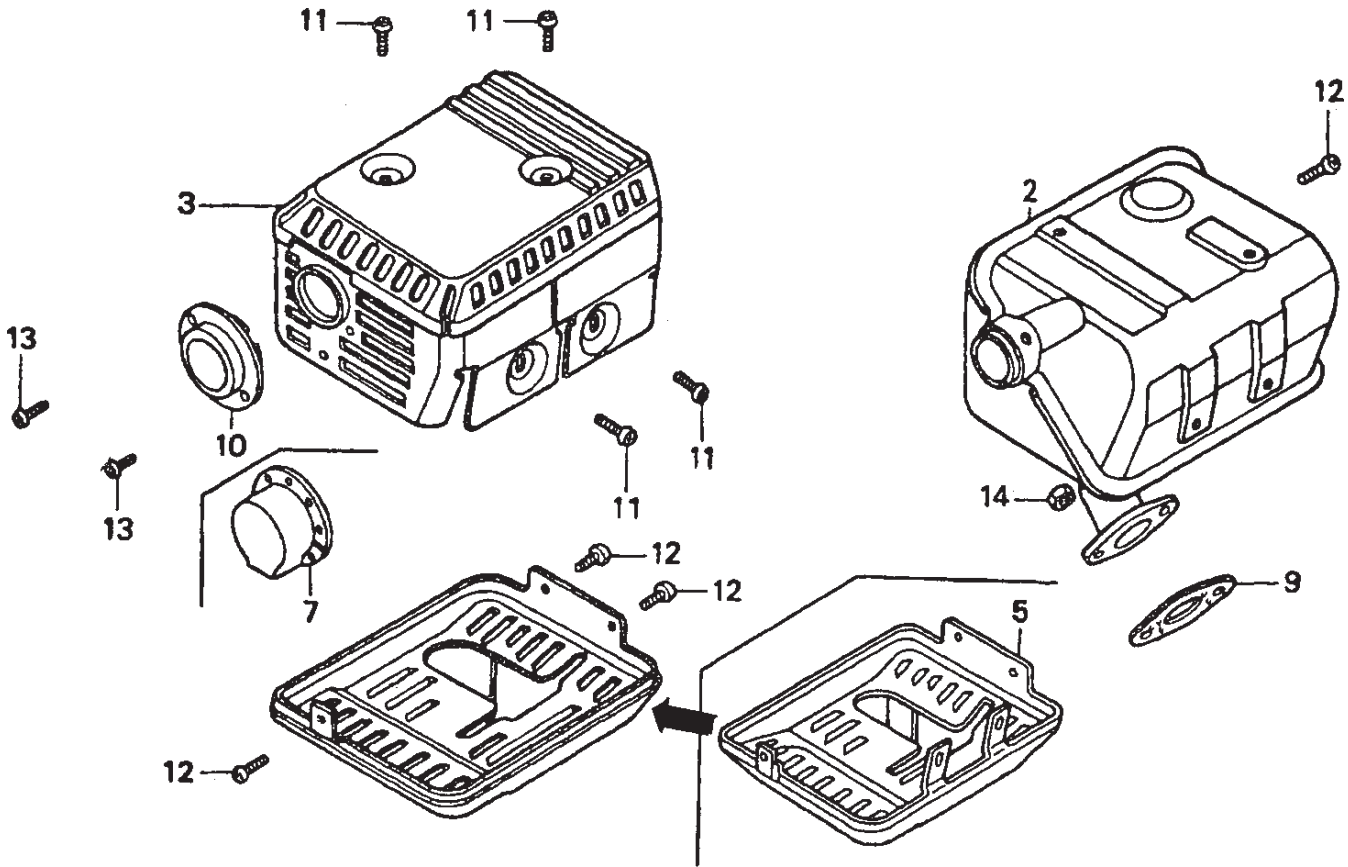

## HONDA GX160K1QX2 — MUFFLER ASSY.

---

<u>NO</u>	<u>PART NO</u>	<u>PART NAME</u>	<u>QTY.</u>	<u>REMARKS</u>
2	18310ZF1000	MUFFLER COMP.	1	
3	19320ZF1H01	MUFFLER PROCTOR (STD)	1	
5	18325ZE1010	PROCTECTOR, LOWER	1	
7	18340ZE1010	DEFLECTOR CP	1	
9	18381ZH8800	GASKET, MUFFLER	1	
10	18522ZE1000	GUIDE, MUFFLER	1	
11	90050ZE1000	TAPPING SCREW 5X8	4	
12	90055ZE1000	TAPPING SCREW 4X6	3	
13	90002ZG0003	TAPPING SCREW 4X8	2	
14	94001080000S	NUT	2	

# HONDA GX160K1QX2 — FUEL TANK ASSY.

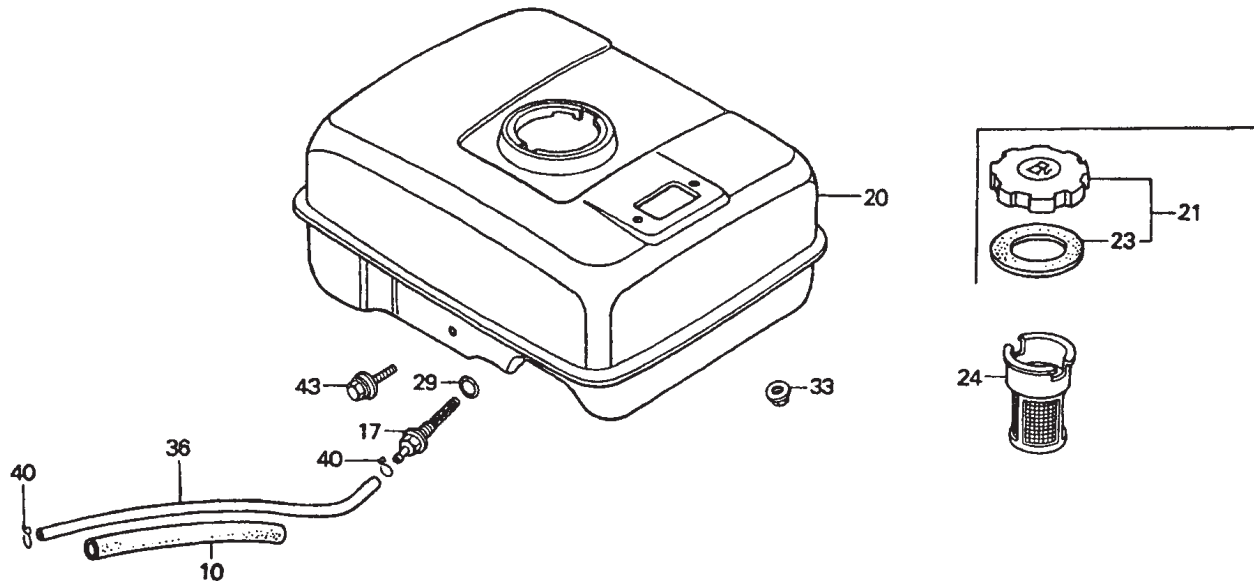

## HONDA GX160K1QX2 — FUEL TANK ASSY.

---

<u>NO</u>	<u>PART NO</u>	<u>PART NAME</u>	<u>QTY.</u>	<u>REMARKS</u>
10	16854ZH8000	RUBBER, SUPPORT (107MM)	1	
17	16955ZE1000	JOINT, FUEL TANK	1	
20	17510ZE1020ZA	FUEL TANK COMP.	1	
21	17620ZH7023	FUEL TANK CAP CP .....	1 .....	INCLUDES ITEMS W/%
23%	17631ZH7003	PACKING	1	
24	17672ZE2W01	FUEL FILTER	1	
29	91353671004	O-RING 14MM	1	
33	9405006000	FLANGE NUT 6MM	2	
36	950014514040	FUEL TUBE 4.5X140	1	
40	9500202080	CLIP, TUBE	2	
43	957010602500	FLANGE BOLT 6X25	1	

# HONDA GX160K1QX2 — COOLING FAN & FLYWHEEL ASSY.

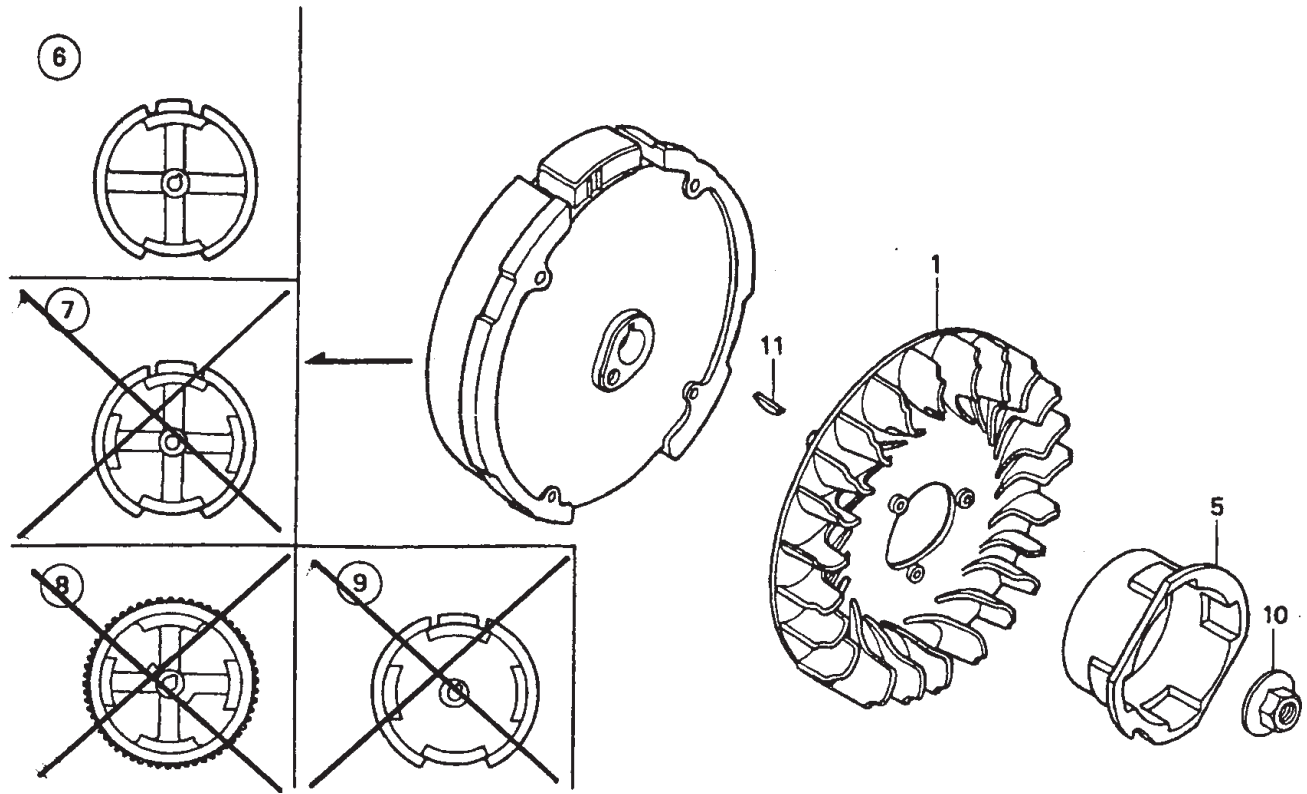

## HONDA GX160K1QX2 — COOLING FAN & FLYWHEEL ASSY.

---

<u>NO</u>	<u>PART NO</u>	<u>PART NAME</u>	<u>QTY.</u>	<u>REMARKS</u>
1	19511ZE1000	COOLING FAN	1	
5	28451ZH8003	STARTER PULLEY	1	
6	31100ZE1010	FLYWHEEL COMP.	1	
10	90201878003	SPECIAL NUT 14MM	1	
11	13331357000	WOODRUFF KEY 25X18	1	

# HONDA GX160K1QX2 — IGNITION COIL ASSY.

---

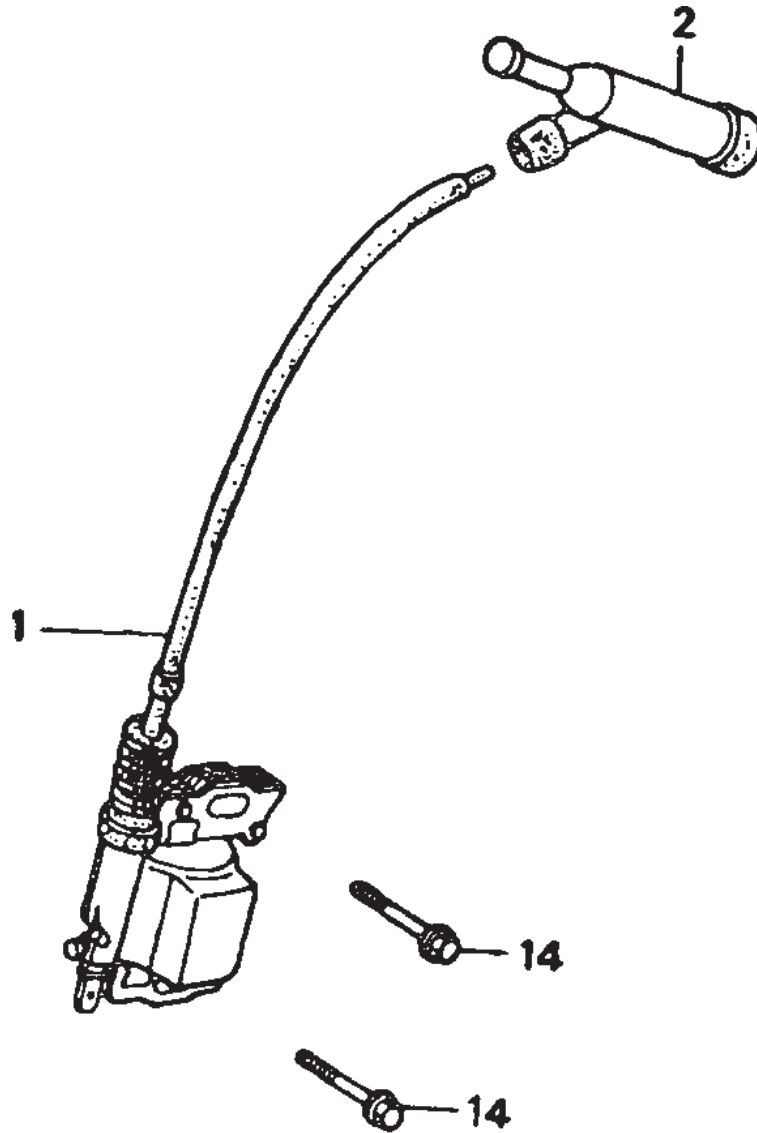

## HONDA GX160K1QX2 — IGNITION COIL ASSY.

---

<u>NO</u>	<u>PART NO</u>	<u>PART NAME</u>	<u>QTY.</u>	<u>REMARKS</u>
1	30500ZE1033	IGNITION COIL CP ASSY.	1	
2	30600ZE1013	SPARK PLUG CAP ASSY.	1	
14	90121952000	FLANGE BOLT 6X25	2	



## HONDA GX160K1QX2 — CONTROL ASSY.

---

<u>NO</u>	<u>PART NO</u>	<u>PART NAME</u>	<u>QTY.</u>	<u>REMARKS</u>
2	16551ZE0010	GOVERNOR ARM	1	
3	16555ZE1000	GOVERNOR ROD	1	
4	16561ZE1020	GOVERNOR SPRING	1	
5	16562ZE1020	SPRING, THROTTLE	1	
7	16500ZH8812	CONTROL ASSY.	1	
9	16571ZH8010	LEVER CONTROL	1	
10	16574ZE1000	LEVER SPRING	1	
11	16575ZH8000	WASHER, CONTROL LEVER	1	
12	16576891000	HOLDER, CABLE	1	
13	16578ZE1000	SPACER, CONTROL LEVER	1	
15	16580ZH8812	CONTROL BASE COMP.	1	
16	16584883300	ADJUSTING SPRING	1	
17	16592ZE1810	SPRING, CABLE, RETURN	1	
18	16594883010	WIRE HOLDER	1	
21	90013883000	FLANGE BOLT 6 X 12	2	
22	90015ZE5010	BOLT, GOVERNOR	1	
24	90605230000	CIR CLIP	1	
26	93500040060H	SCREW 4 X 6	1	
27	93500050250H	SCREW 5X 25	1	
28	93500050160A	SCREW 5X 16	1	
29	90114SA0000	LOCK NUT 6MM	1	
30	940500600	FLANGE NUT 6MM	1	

# TERMS AND CONDITIONS OF SALE — PARTS

## PAYMENT TERMS

Terms of payment for parts are net 30 days.

## FREIGHT POLICY

All parts orders will be shipped collect or prepaid with the charges added to the invoice. All shipments are F.O.B. point of origin. Multiquip's responsibility ceases when a signed manifest has been obtained from the carrier, and any claim for shortage or damage must be settled between the consignee and the carrier.

## MINIMUM ORDER

The minimum charge for orders from Multiquip is \$15.00 net. Customers will be asked for instructions regarding handling of orders not meeting this requirement.

## RETURNED GOODS POLICY

Return shipments will be accepted and credit will be allowed, subject to the following provisions:

1. A Returned Material Authorization must be approved by Multiquip prior to shipment.
2. To obtain a Return Material Authorization, a list must be provided to Multiquip Parts Sales that defines item numbers, quantities, and descriptions of the items to be returned.
  - a. The parts numbers and descriptions must match the current parts price list.
  - b. The list must be typed or computer generated.
  - c. The list must state the reason(s) for the return.
  - d. The list must reference the sales order(s) or invoice(s) under which the items were originally purchased.
  - e. The list must include the name and phone number of the person requesting the RMA.
3. A copy of the Return Material Authorization must accompany the return shipment.
4. Freight is at the sender's expense. All parts must be returned freight prepaid to Multiquip's designated receiving point.

5. Parts must be in new and resalable condition, in the original Multiquip package (if any), and with Multiquip part numbers clearly marked.
6. The following items are not returnable:
  - a. Obsolete parts. (If an item is in the price book and shows as being replaced by another item, it is obsolete.)
  - b. Any parts with a limited shelf life (such as gaskets, seals, "O" rings, and other rubber parts) that were purchased more than six months prior to the return date.
  - c. Any line item with an extended dealer net price of less than \$5.00.
  - d. Special order items.
  - e. Electrical components.
  - f. Paint, chemicals, and lubricants.
  - g. Decals and paper products.
  - h. Items purchased in kits.
7. The sender will be notified of any material received that is not acceptable.
8. Such material will be held for five working days from notification, pending instructions. If a reply is not received within five days, the material will be returned to the sender at his expense.
9. Credit on returned parts will be issued at dealer net price at time of the original purchase, less a 15% restocking charge.
10. In cases where an item is accepted, for which the original purchase document can not be determined, the price will be based on the list price that was effective twelve months prior to the RMA date.
11. Credit issued will be applied to future purchases only.

## PRICING AND REBATES

Prices are subject to change without prior notice. Price changes are effective on a specific date and all orders received on or after that date will be billed at the revised price. Rebates for price declines and added charges for price increases will not be made for stock on hand at the time of any price change.

Multiquip reserves the right to quote and sell direct to Government agencies, and to Original Equipment Manufacturer accounts who use our products as integral parts of their own products.

## SPECIAL EXPEDITING SERVICE

A \$35.00 surcharge will be added to the invoice for special handling including bus shipments, insured parcel post or in cases where Multiquip must personally deliver the parts to the carrier.

## LIMITATIONS OF SELLER'S LIABILITY

Multiquip shall not be liable hereunder for damages in excess of the purchase price of the item with respect to which damages are claimed, and in no event shall Multiquip be liable for loss of profit or good will or for any other special, consequential or incidental damages.

## LIMITATION OF WARRANTIES

No warranties, express or implied, are made in connection with the sale of parts or trade accessories nor as to any engine not manufactured by Multiquip. Such warranties made in connection with the sale of new, complete units are made exclusively by a statement of warranty packaged with such units, and Multiquip neither assumes nor authorizes any person to assume for it any other obligation or liability whatever in connection with the sale of its products. Apart from such written statement of warranty, there are no warranties, express, implied or statutory, which extend beyond the description of the products on the face hereof.

Effective: February 22, 2006



# OPERATION AND PARTS MANUAL

## HERE'S HOW TO GET HELP

PLEASE HAVE THE MODEL AND SERIAL  
NUMBER ON-HAND WHEN CALLING

### UNITED STATES

#### ***Multiquip Corporate Office***

18910 Wilmington Ave. Tel. (800) 421-1244  
Carson, CA 90746 Fax (800) 537-3927  
Contact: mq@multiquip.com

#### ***Service Department***

800-421-1244 Fax: 310-537-4259  
310-537-3700

#### ***Technical Assistance***

800-478-1244 Fax: 310-943-2238

#### ***MQ Parts Department***

800-427-1244 Fax: 800-672-7877  
310-537-3700 Fax: 310-637-3284

#### ***Warranty Department***

800-421-1244 Fax: 310-943-2249  
310-537-3700

---

### MEXICO

#### ***MQ Cipsa***

Carr. Fed. Mexico-Puebla KM 126.5 Tel: (52) 222-225-9900  
Momoxpan, Cholula, Puebla 72760 Mexico Fax: (52) 222-285-0420  
Contact: pmastretta@cipsa.com.mx

### CANADA

#### ***Multiquip***

4110 Industriel Boul. Tel: (450) 625-2244  
Laval, Quebec, Canada H7L 6V3 Tel: (877) 963-4411  
Contact: jmartin@multiquip.com Fax: (450) 625-8664

---

### UNITED KINGDOM

#### ***Multiquip (UK) Limited Head Office***

Unit 2, Northpoint Industrial Estate, Tel: 0161 339 2223  
Globe Lane, Fax: 0161 339 3226  
Dukinfield, Cheshire SK16 4UJ  
Contact: sales@multiquip.co.uk

© COPYRIGHT 2011, MULTIQUIP INC.

Multiquip Inc, the MQ logo and the Mikasa logo are registered trademarks of Multiquip Inc. and may not be used, reproduced, or altered without written permission. All other trademarks are the property of their respective owners and used with permission.

This manual MUST accompany the equipment at all times. This manual is considered a permanent part of the equipment and should remain with the unit if resold.

The information and specifications included in this publication were in effect at the time of approval for printing. Illustrations, descriptions, references and technical data contained in this manual are for guidance only and may not be considered as binding. Multiquip Inc. reserves the right to discontinue or change specifications, design or the information published in this publication at any time without notice and without incurring any obligations.

Your Local Dealer is:

