

# OPERATION AND PARTS MANUAL





*Mikasa* SERIES  
**MODEL MVH306GH**  
**REVERSIBLE PLATE COMPACTOR**  
**(HONDA GX270K1SMX2 GASOLINE ENGINE)**

Revision #7 (08/23/11)

To find the latest revision of this  
publication, visit our website at:  
[www.multiquip.com](http://www.multiquip.com)



**THIS MANUAL MUST ACCOMPANY THE EQUIPMENT AT ALL TIMES.**

 <b>WARNING</b> 
<b>CALIFORNIA — Proposition 65 Warning</b>
Engine exhaust and some of its constituents are known to the State of California to cause cancer, birth defects and other reproductive harm.



# TABLE OF CONTENTS

## MIKASA MVH306GH REVERSIBLE PLATE COMPACTOR

Proposition 65 Warning .....	2
Table Of Contents .....	4
Parts Ordering Procedures .....	5
Safety Information .....	6-10
Specifications .....	11
Dimensions .....	12
General Information .....	13
Components .....	14
Inspection .....	16-17
Operation .....	18-21
Maintenance .....	22-25
Troubleshooting (Engine) .....	26
Troubleshooting (Compactor) .....	27

## PARTS ILLUSTRATIONS

Explanation Of Code In Remarks Column .....	28
Suggested Spare Parts .....	29
Nameplate and Decals .....	30-31
Vibrating Plate Assembly .....	32-33
Base and Engine Assembly .....	34-37
Vibrator Assembly .....	38-39
Control Handle Assembly .....	40-43
Hand Pump Assembly .....	44-45

## HONDA GX270K1SMX2 GASOLINE ENGINE

Air Cleaner Assembly .....	46-47
Camshaft Assembly .....	48-49
Carburetor Assembly .....	50-51
Control Assembly .....	52-53
Crankcase Cover Assembly .....	54-55
Crankshaft Assembly .....	56-57
Cylinder Barrel Assembly .....	58-59
Cylinder Head Assembly .....	60-61
Fan Cover Assembly .....	62-63
Flywheel Assembly .....	64-65
Fuel Tank Assembly .....	66-67
Ignition Coil Assembly .....	68-69
Muffler Assembly .....	70-71
Piston Assembly .....	72-73
Recoil Starter Assembly .....	74-75
Labels Assembly .....	76-77

Terms and Conditions Of Sale — Parts .....	78
--	----

### NOTICE

*Specification and part number are subject to change without notice.*

# PARTS ORDERING PROCEDURES

## Ordering parts has never been easier! Choose from three easy options:

Effective:  
January 1<sup>st</sup>, 2006

www.multiquip.com



### Order via Internet (Dealers Only):

Order parts on-line using Multiquip's SmartEquip website!

- View Parts Diagrams
- Order Parts
- Print Specification Information



If you have an MQ Account, to obtain a Username and Password, E-mail us at: [parts@multiquip.com](mailto:parts@multiquip.com).

To obtain an MQ Account, contact your District Sales Manager for more information.

Goto [www.multiquip.com](http://www.multiquip.com) and click on

**Order Parts** to log in and save!

Use the **internet** and qualify for a **5% Discount** on *Standard orders* for all orders which include complete part numbers.\*

Note: Discounts Are Subject To Change



### Order via Fax (Dealers Only):

All customers are welcome to order parts via Fax.

**Domestic (US) Customers dial:**

1-800-6-PARTS-7 (800-672-7877)

**Fax** your order in and qualify for a **2% Discount** on *Standard orders* for all orders which include complete part numbers.\*

Note: Discounts Are Subject To Change



**Order via Phone: Domestic (US) Dealers Call:**  
1-800-427-1244

### Non-Dealer Customers:

Contact your local Multiquip Dealer for parts or call 800-427-1244 for help in locating a dealer near you.



**International Customers** should contact their local Multiquip Representatives for Parts Ordering information.

## When ordering parts, please supply:

- |   |  |
|---|--|
| <input type="checkbox"/> Dealer Account Number                                | <input type="checkbox"/> Specify Preferred Method of Shipment:                             |
| <input type="checkbox"/> Dealer Name and Address                              | <input checked="" type="checkbox"/> UPS/Fed Ex <input checked="" type="checkbox"/> DHL     |
| <input type="checkbox"/> Shipping Address (if different than billing address) | <input checked="" type="checkbox"/> Priority One <input checked="" type="checkbox"/> Truck |
| <input type="checkbox"/> Return Fax Number                                    | <input checked="" type="checkbox"/> Ground   |
| <input type="checkbox"/> Applicable Model Number                              | <input checked="" type="checkbox"/> Next Day   |
| <input type="checkbox"/> Quantity, Part Number and Description of Each Part   | <input checked="" type="checkbox"/> Second/Third Day                                       |

### NOTICE

All orders are treated as *Standard Orders* and will ship the same day if received prior to 3PM PST.

WE ACCEPT ALL MAJOR CREDIT CARDS!



# SAFETY INFORMATION

Do not operate or service the equipment before reading the entire manual. Safety precautions should be followed at all times when operating this equipment. Failure to read and understand the safety messages and operating instructions could result in injury to yourself and others.



## SAFETY MESSAGES

The four safety messages shown below will inform you about potential hazards that could injure you or others. The safety messages specifically address the level of exposure to the operator and are preceded by one of four words: **DANGER**, **WARNING**, **CAUTION** or **NOTICE**.

## SAFETY SYMBOLS

**! DANGER**

Indicates a hazardous situation which, if not avoided, **WILL** result in **DEATH** or **SERIOUS INJURY**.

**! WARNING**

Indicates a hazardous situation which, if not avoided, **COULD** result in **DEATH** or **SERIOUS INJURY**.

**! CAUTION**

Indicates a hazardous situation which, if not avoided, **COULD** result in **MINOR** or **MODERATE INJURY**.

**NOTICE**

Addresses practices not related to personal injury.

Potential hazards associated with the operation of this equipment will be referenced with hazard symbols which may appear throughout this manual in conjunction with safety messages.

Symbol	Safety Hazard
	Lethal exhaust gas hazards
	Explosive fuel hazards
	Burn hazards
	Respiratory hazards
	Accidental starting hazards
	Eye and hearing hazards
	Rotating parts hazards

# SAFETY INFORMATION

## GENERAL SAFETY

### CAUTION

- **NEVER** operate this equipment without proper protective clothing, shatterproof glasses, respiratory protection, hearing protection, steel-toed boots and other protective devices required by the job or city and state regulations.



- **NEVER** operate this equipment when not feeling well due to fatigue, illness or when under medication.



- **NEVER** operate this equipment under the influence of drugs or alcohol.



- **ALWAYS** check the equipment for loosened threads or bolts before starting.
- **DO NOT** use the equipment for any purpose other than its intended purposes or applications.
- **ALWAYS** clear the work area of any debris, tools, etc. that would constitute a hazard while the equipment is in operation.

### NOTICE

- This equipment should only be operated by trained and qualified personnel 18 years of age and older.
- Whenever necessary, replace nameplate, operation and safety decals when they become difficult read.
- Manufacturer does not assume responsibility for any accident due to equipment modifications. Unauthorized equipment modification will void all warranties.
- **NEVER** use accessories or attachments that are not recommended by Multiquip for this equipment. Damage to the equipment and/or injury to user may result.
- **ALWAYS** know the location of the nearest **fire extinguisher**.
- **ALWAYS** know the location of the nearest **first aid kit**.
- **ALWAYS** know the location of the nearest phone or **keep a phone on the job site**. Also, know the phone numbers of the nearest **ambulance, doctor and fire department**. This information will be invaluable in the case of an emergency.

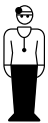

# SAFETY INFORMATION

## COMPACTOR SAFETY

### DANGER

- **NEVER** operate the equipment in an explosive atmosphere or near combustible materials. An explosion or fire could result causing severe **bodily harm or even death.**



### WARNING

- **NEVER** disconnect any **emergency or safety devices.** These devices are intended for operator safety. Disconnection of these devices can cause severe injury, bodily harm or even death. Disconnection of any of these devices will void all warranties.

### CAUTION

- **NEVER** lubricate components or attempt service on a running machine.

### NOTICE

- **ALWAYS** keep the machine in proper running condition.
- Fix damage to machine and replace any broken parts immediately.
- **ALWAYS** store equipment properly when it is not being used. Equipment should be stored in a clean, dry location out of the reach of children and unauthorized personnel.

## ENGINE SAFETY

### DANGER

- The engine fuel exhaust gases contain poisonous carbon monoxide. This gas is colorless and odorless, and can cause death if inhaled.
- The engine of this equipment requires an adequate free flow of cooling air. **NEVER** operate this equipment in any enclosed or narrow area where free flow of the air is restricted. If the air flow is restricted it will cause injury to people and property and serious damage to the equipment or engine.



### WARNING

- **DO NOT** place hands or fingers inside engine compartment when engine is running.
- **NEVER** operate the engine with heat shields or guards removed.
- Keep fingers, hands hair and clothing away from all moving parts to prevent injury.
- **DO NOT** remove the radiator cap while the engine is hot. High pressure boiling water will gush out of the radiator and severely scald any persons in the general area of the compactor.
- **DO NOT** remove the coolant drain plug while the engine is hot. Hot coolant will gush out of the coolant tank and severely scald any persons in the general area of the compactor.
- **DO NOT** remove the engine oil drain plug while the engine is hot. Hot oil will gush out of the oil tank and severely scald any persons in the general area of the compactor.



### CAUTION

- **NEVER** touch the hot exhaust manifold, muffler or cylinder. Allow these parts to cool before servicing equipment.



### NOTICE

- **NEVER** run engine without an air filter or with a dirty air filter. Severe engine damage may occur. Service air filter frequently to prevent engine malfunction.
- **NEVER** tamper with the factory settings of the engine or engine governor. Damage to the engine or equipment can result if operating in speed ranges above the maximum allowable.
- **NEVER** tip the engine to extreme angles during lifting as it may cause oil to gravitate into the cylinder head, making the engine start difficult.





# SAFETY INFORMATION

## FUEL SAFETY

### DANGER

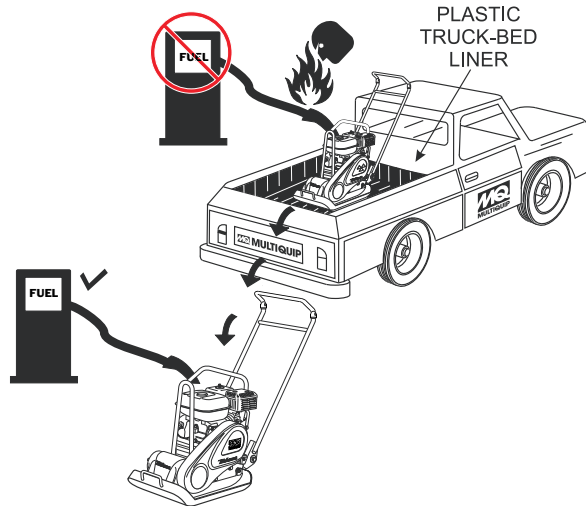
- **DO NOT** add fuel to equipment if it is placed inside truck bed with plastic liner. Possibility exists of explosion or fire due to static electricity.





- **DO NOT** start the engine near spilled fuel or combustible fluids. Diesel fuel is extremely flammable and its vapors can cause an explosion if ignited.
- **ALWAYS** refuel in a well-ventilated area, away from sparks and open flames.
- **ALWAYS** use extreme caution when working with **flammable** liquids.
- **DO NOT** fill the fuel tank while the engine is running or hot.
- **DO NOT** overfill tank, since spilled fuel could ignite if it comes into contact with hot engine parts or sparks from the ignition system.
- Store fuel in appropriate containers, in well-ventilated areas and away from sparks and flames.
- **NEVER** use fuel as a cleaning agent.
- **DO NOT** smoke around or near the equipment. Fire or explosion could result from fuel vapors or if fuel is spilled on a hot engine. 

## BATTERY SAFETY (ELECTRIC START ONLY)

### DANGER

- **DO NOT** drop the battery. There is a possibility that the battery will explode.
- **DO NOT** expose the battery to open flames, sparks, cigarettes, etc. The battery contains combustible gases and liquids. If these gases and liquids come into contact with a flame or spark, an explosion could occur. 

### WARNING

- **ALWAYS** wear safety glasses when handling the battery to avoid eye irritation. The battery contains acids that can cause injury to the eyes and skin. 
- Use well-insulated gloves when picking up the battery.
- **ALWAYS** keep the battery charged. If the battery is not charged, combustible gas will build up.
- **DO NOT** charge battery if frozen. Battery can explode. When frozen, warm the battery to at least 61°F (16°C).
- **ALWAYS** recharge the battery in a well-ventilated environment to avoid the risk of a dangerous concentration of combustible gases.
- If the battery liquid (dilute sulfuric acid) comes into contact with **clothing or skin**, rinse skin or clothing immediately with plenty of water. 
- If the battery liquid (dilute sulfuric acid) comes into contact with **eyes**, rinse eyes immediately with plenty of water and contact the nearest doctor or hospital to seek medical attention.

### CAUTION

- **ALWAYS** disconnect the **NEGATIVE** battery terminal before performing service on the equipment.
- **ALWAYS** keep battery cables in good working condition. Repair or replace all worn cables.

## TRANSPORTING SAFETY

### CAUTION

- NEVER allow any person or animal to stand underneath the equipment while lifting.

### NOTICE

- Before lifting, make sure that the equipment parts (hook and vibration insulator) are not damaged and screws are not loose or missing.
- Always make sure crane or lifting device has been properly secured to the lifting bail (hook) of the equipment.
- **ALWAYS** shutdown engine before transporting.
- **NEVER** lift the equipment while the engine is running.
- Tighten fuel tank cap securely and close fuel cock to prevent fuel from spilling.
- Use adequate lifting cable (wire or rope) of sufficient strength.
- Use one point suspension hook and lift straight upwards.
- **DO NOT** lift machine to unnecessary heights.
- **ALWAYS** tie down equipment during transport by securing the equipment with rope.

## ENVIRONMENTAL SAFETY

### NOTICE

- Dispose of hazardous waste properly. Examples of potentially hazardous waste are used motor oil, fuel and fuel filters. 
- **DO NOT** use food or plastic containers to dispose of hazardous waste.
- **DO NOT** pour waste, oil or fuel directly onto the ground, down a drain or into any water source.

# SPECIFICATIONS

**Table 1. MVH-306GH Reversible Plate Compactor Specifications**

Centrifugal Force	10,125 lb (4,602 kg)
Vibration Frequency	4,400 vpm (70 Hz)
Traveling Speed	0 to 75 ft/min (0 to 23 m/min)
Plate Size (L x W)	18 x 34 in (45.72 x 86.36 cm)
With External Plate Size (L x W)	24 x 34 in (60.96 x 86.36 cm)
Max. Area of Compaction (no extensions)	6,750 sq. ft. (2,057 sq. meters)
Overall Length	61.8 in (1570 mm)
Overall Width	18.0 in (457 mm)
Overall Height (with handle)	44.1 in (1120 mm)
Overall Height (without handle)	31.7 in (805 mm)
Operating Weight D/DS	673 lbs. ( 306 kg)
Operating Weight (with extension plates)	706 lbs. (321kg)

**Table 2. Engine Specifications**

Table 2. Engine Specifications		
Engine	<b>Model</b>	<b>HONDA GX270K1SMX2</b>
	Type	4-Stroke, Single Cylinder, OHV, Gasoline Engine
	Bore X Stroke	3.0 in. X 2.3 in. (77 mm x 58 mm.)
	Displacement	16.5 cu-in (270 cm <sup>3</sup> )
	Max Output	9.0 H.P. (6.7 KW) @ 3600 R.P.M.
	Fuel Tank Capacity	1.59 gallons (6.0 liters)
	Fuel	Unleaded Automobile Gasoline
	Lube Oil Capacity	1.16 quarts (1.1 liters)
	Speed Control Method	Centrifugal Fly-weight Type
	Starting Method	Recoil Start
Dimension (L x W x H)	14.0 x 16.9 X 16.1 in. (355 X 430 X 410 mm.)	
Dry Net Weight	55.1 lbs (25 Kg.)	

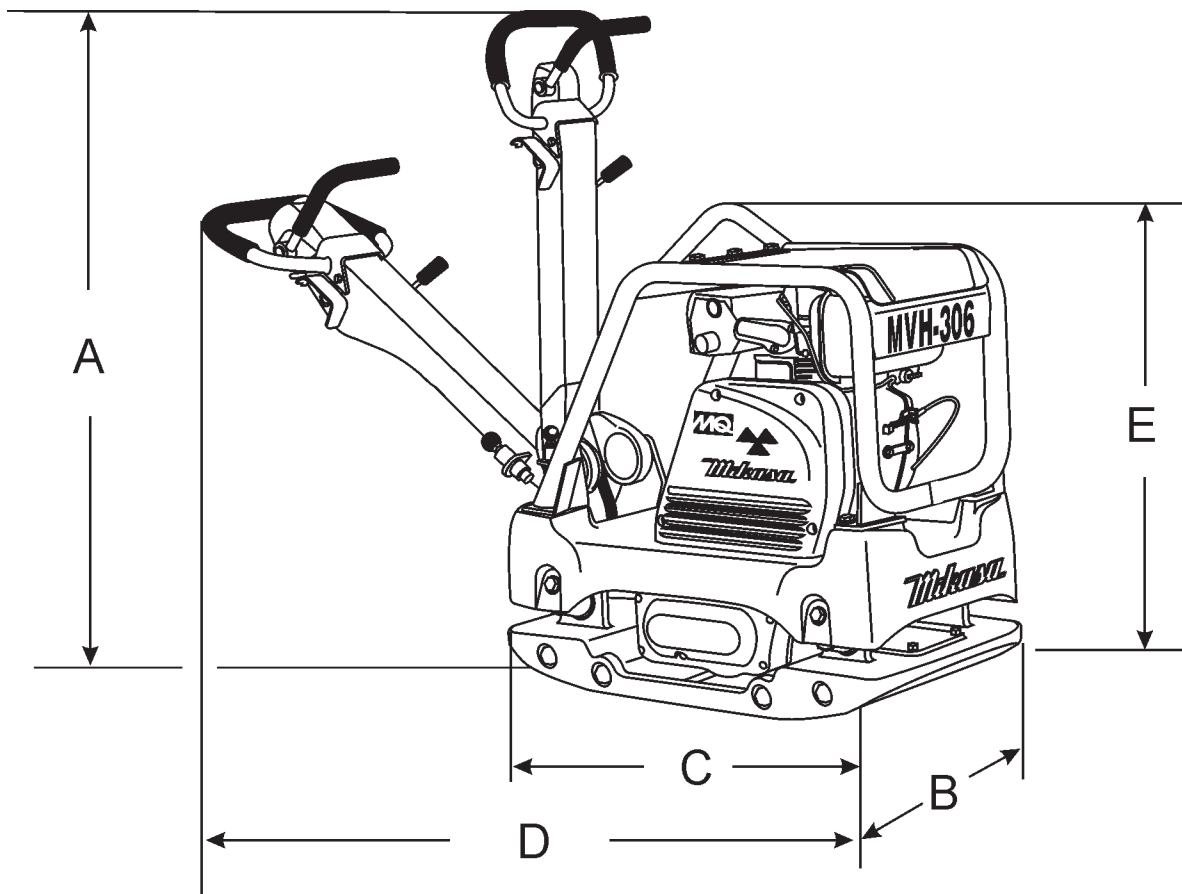

Figure 3. MVH306GH Reversible Plate Compactor Dimensions

Table 3. Dimensions	
REF.	DIMENSIONS
A	53 in. (134.6 cm.)
B	18 in. (46 cm.)
C	34 in. (86 cm.)
D	63.8 in. (162 cm.)
E	31.7 (80.5 cm.)

## Plate Compactor

The Mikasa MVH306GH is a walk behind, reversible plate compactor designed for the compaction of sand, clay and asphalt. This plate compactor is a powerful compacting tool capable of applying a tremendous force in consecutive high frequency vibrations to a soil surface. Its applications include soil compacting for road, embankments and reservoirs as well as backfilling for gas pipelines, water pipelines and cable installation work.

## Vibratory Plates

The vibratory plates of the MVH306GH produce low amplitude high frequency vibrations, designed to compact granular soils.

The resulting vibrations cause forward motion. The engine and handle are vibration isolated from the vibrating plate. The heavier the plate, the more compaction force it generates.

## Reversible Vibratory Plates

Reversible vibratory plates have two eccentric weights that allow a smooth transition for forward and reverse travel, plus increased compaction force as the result of dual weights.

Due to their weight and force, reversible plates are ideal for semi-cohesive soils.

## Frequency/Speed

The compactor's vibrating plate maximum frequency is 4400 vpm (vibrations per minute). The forward and reverse travel speed of the compactor is approximately 75 ft./minute (23 meters/minute).

## Engine

The Mikasa MVH306GH Plate Compactor is equipped with a GX270K1-SMX2 (recoil start) gasoline engine.

## Controls

Before starting the MVH306GH Plate Compactor, identify and understand the function of the controls and components as indicated in Figure 4.

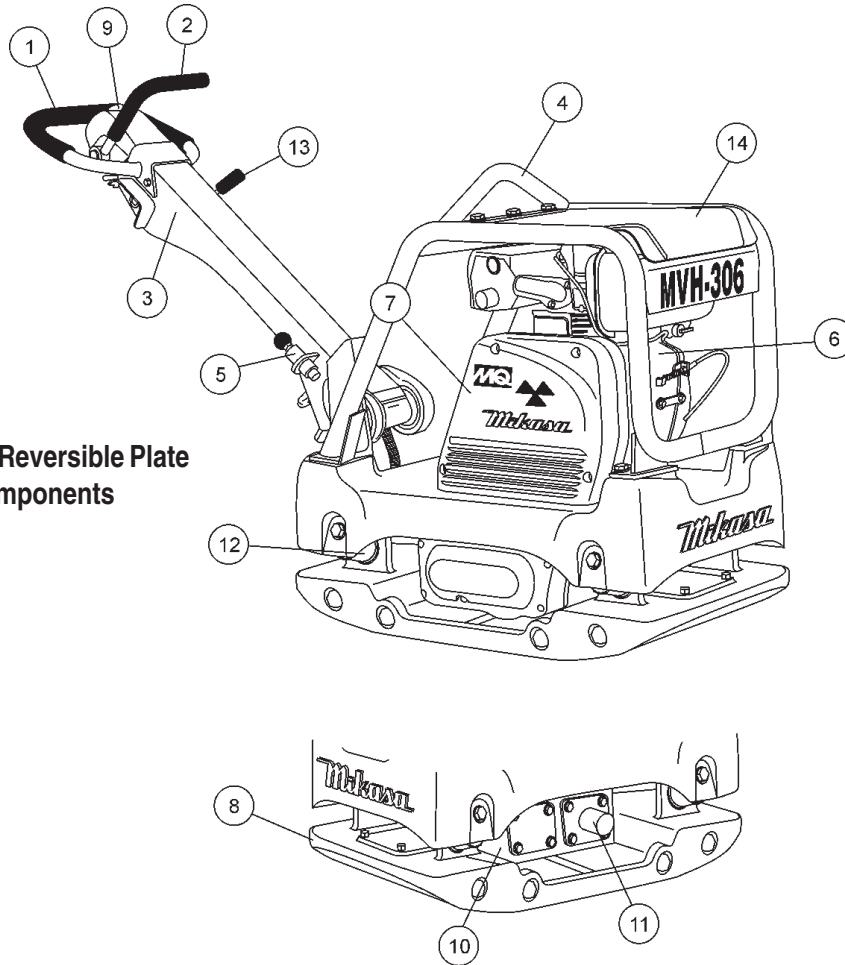

Figure 4. MVH306GH Reversible Plate Compactor Components

Figure 4 illustrates the location of the major components for the MVH306GH Reversible Plate Compactor. The function of each component is described below:

1. **Hand Grip** – When operating the compactor use this hand grip to maneuver the compactor.
2. **Forward & Reverse Lever** – *Push* the lever forward, the compactor will move in a forward direction, *pull* the lever backwards, the compactor will move in backwards direction. Placing the lever in the middle (midway) will cause the compactor not to move (neutral).
3. **Handle Bar** – When operating the compactor, this handle is to be in the downward position. When the compactor is to be *stored*, move the handle bar to the upright position.
4. **Guard Hook** - Used to lift the machine with crane or other lifting device.
5. **Stopper** - Locks the handle in place in the upward position for stowing.
6. **Engine** – This plate compactor uses a **GX270K1-SMX2** gasoline engine. Refer to the owner's manual for engine information and related topics.
7. **Belt Cover** – Remove this cover to gain access to the V-belts. **NEVER** run the compactor without the V-belt cover. If the V-belt cover is not installed, the possibility exist that your hand may get caught between the V-belt and clutch, thus causing serious injury and bodily harm.
8. **Base Plate** – Designed to compact sand, clay, and asphalt.
9. **Oil Reservoir** – Fill with Shell Tellus Oil 46 or equivalent grade hydraulic oil.
10. **Vibration Case** – Encloses the eccentric, gears and counter weights.
11. **Hydraulic Cylinder** – Activated by moving the travel lever. The cylinder controls the direction of movement by the plate compactor.
12. **Shock Absorber** – Protects plate compactor from damage by absorbing vibration during operation.
13. **Throttle Lever** – Controls speed of the plate compactor. Place straight vertically to start, *push* fully counterclockwise for full throttle and fully clockwise to stop plate compactor.
14. **Rubber Cover** – Lift this rubber cover to gain access to the fuel tank.

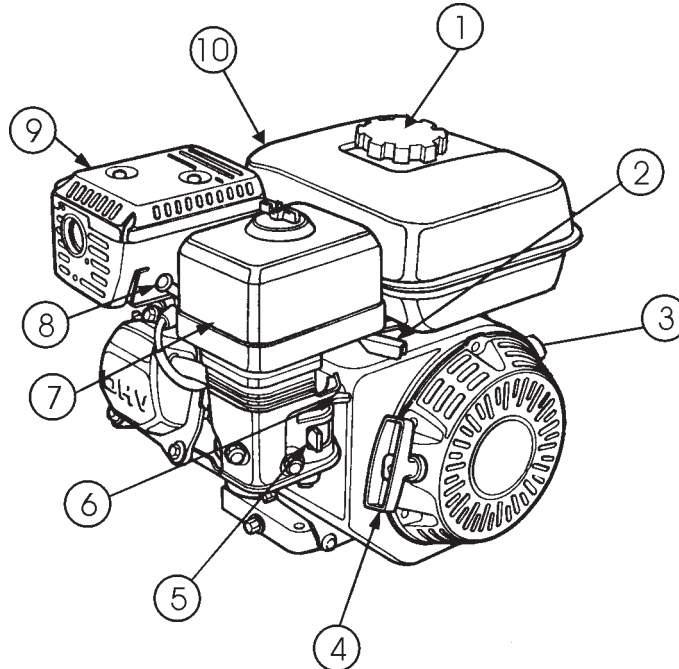

Figure 5. Honda GX270 Engine Components

## INITIAL SERVICING

The engine (Figure 5) must be checked for proper lubrication and filled with fuel prior to operation. Refer to the manufacturer's engine manual for instructions & details of operation and servicing. The engine shown above is a **HONDA** engine, operation for other types of engines may vary somewhat.

1. **Fuel Filler Cap** – Remove this cap to add unleaded gasoline to the fuel tank. Make sure cap is tightened securely. **DO NOT** over fill.

### WARNING



Add fuel to the tank only when the engine is stopped and has cooled down. In the event of a fuel spill, **DO NOT** attempt to start the engine until the fuel residue has been completely wiped up and the area surrounding the engine is dry.

2. **Throttle Lever** – Used to adjust engine RPM speed (lever advanced forward **SLOW**, lever back toward operator **FAST**).
3. **Engine ON/OFF Switch** – ON position permits engine starting, OFF position stops engine operations.
4. **Recoil Starter (pull rope)** – Manual-starting method. Pull the starter grip until resistance is felt, then pull briskly and smoothly.
5. **Fuel Valve Lever** – **OPEN** to let fuel flow, **CLOSE** to stop the flow of fuel.

6. **Choke Lever** – Used in the starting of a cold engine, or in cold weather conditions. The choke enriches the fuel mixture.
7. **Air Cleaner** – Prevents dirt and other debris from entering the fuel system. Remove wing-nut on top of air filter canister to gain access to filter element.

### NOTICE

Operating the engine without an air filter, with a damaged air filter, or a filter in need of replacement will allow dirt to enter the engine, causing rapid engine wear.

8. **Spark Plug** – Provides spark to the ignition system. Set spark plug gap to 0.6 - 0.7 mm (0.028 - 0.031 inch) Clean spark plug once a week.
9. **Muffler** – Used to reduce noise and emissions.

### WARNING



Engine components can generate extreme heat. To prevent burns, **DO NOT** touch these areas while the engine is running or immediately after operating. **NEVER** operate the engine with the muffler removed.

10. **Fuel Tank** – Holds unleaded gasoline. For additional information refer to engine owner's manual.

## CAUTION



**NEVER** operate the compactor in a confined area or enclosed area structure that does not provide ample **free flow of air**.

## CAUTION

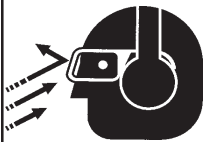

**ALWAYS** wear approved eye and hearing protection before operating the compactor.

### Before Starting

1. Read safety instructions at the beginning of manual.
2. Familiarize yourself with the operating and control elements of the machine and the working environment. This includes obstacles in the working area, bearing capacity of the ground and the necessary safety provisions.
3. Check the air filter for dirt and dust. If air filter is dirty, replace air filter with a new one as required.
4. Check fastening nuts and bolts for tightness. Loose threads may cause damage to the machine when vibrating.
5. Understand the geographical features and regulations of the job site.
6. Clean the compactor, removing dirt and dust. Particularly, the bottom of the plate, engine cooling air inlet.



### Checking Engine Oil Level

1. To check the engine oil level, place the compactor on secure level ground with the engine stopped.
2. Remove the dipstick from the engine oil filler hole (Figure 6) and wipe it clean.
3. Insert and remove the dipstick without screwing it into the filler neck. Check the oil level shown on the dipstick.

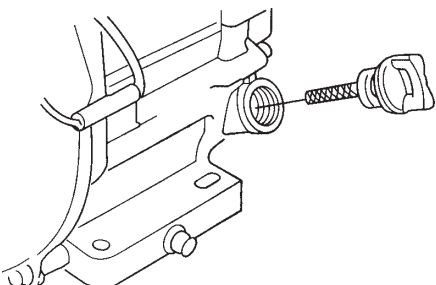

Figure 6. Engine Oil Dipstick Removal

4. If the oil level is low (Figure 7), fill to the edge of the oil filler hole with the recommended oil type (Table 4). Maximum oil capacity is 1.16 quarts (1.10 liters).

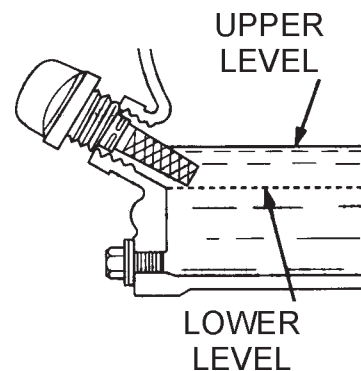

Figure 7. Engine Oil Level

Table 4. Oil Type

Season	Temperature	Oil Type
Summer	25°C or Higher	SAE 10W-30
Spring/Fall	25°C~10°C	SAE 10W-30/20
Winter	0°C or Lower	SAE 10W-10

### Checking the Hydraulic Oil Level

1. To check the engine oil level, place the compactor on secure level ground with the engine stopped.
2. Remove the hydraulic oil breather cap located at the top of the hydraulic oil tank (Figure 8).
3. Using a 24 mm wrench, remove the hydraulic oil filler plug.
3. Visually inspect to determine if hydraulic oil level is low. If oil level is low add Shell Tellus 46 hydraulic oil or equivalent through the hand pump oil filler port.

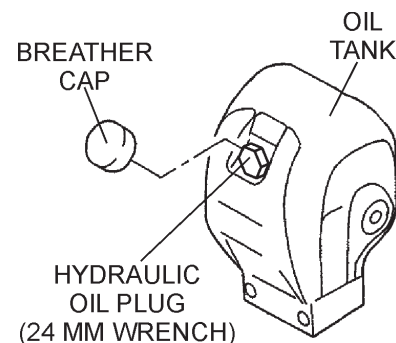

Figure 8. Hydraulic Oil Filler Plug Removal

## CAUTION

**DO NOT** overfill hydraulic oil tank. This could cause oil leaks and sluggish operation. Clean cap and surrounding area before opening to prevent dirt from entering oil tank.

- When adding hydraulic oil, only fill to the specified oil level as marked on the front of the hydraulic oil tank (Figure 9). **DO NOT** overfill.



Figure 9. Oil Tank (Front View)

## Checking the Air Cleaner

- Loosen the wing nut and remove the air cleaner cover as shown in Figure 10.
- Remove the paper filter element and inspect it for signs of wear or dirt. If paper filter element is dirty, clean or replace element.

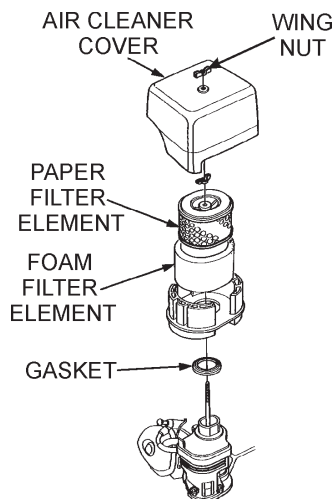

Figure 10. Air Cleaner Element

## DANGER



### EXPLOSIVE FUEL!

Motor fuels are highly flammable and can be dangerous if mishandled. **DO NOT** smoke while refueling. **DO NOT** attempt to refuel if the engine is **hot** or **running**.

## Checking The Fuel

- Remove the fuel cap located on top of fuel tank.
- Visually inspect to see if fuel level is low. If fuel is low, replenish with unleaded gasoline. (Figure 11).
- When refueling, be sure to use a strainer for filtration. **DO NOT** top-off fuel. Wipe up any spilled fuel.

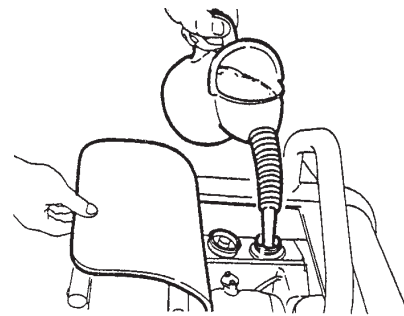

Figure 11. Refueling

## CAUTION



**DO NOT** attempt to operate the compactor until the Safety, General Information and Inspection sections of this manual have been **read and thoroughly understood**.

This section is intended to assist the operator with the **initial start-up** of the compactor. It is extremely important that this section be read carefully before attempting to use the compactor in the field.

Refer to Figure 4 for the location of controls and components.

### Releasing the Handle

1. Pull the handle release pin, (Figure 12) then push down on the hand grip to release the handle.

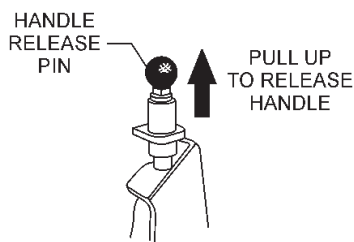
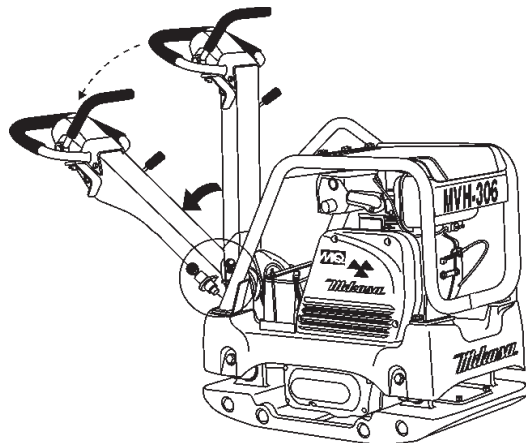

Figure 12. Handle Release Pin

### Adjusting Handle Height

The height of the handle is adjustable for your comfort .

1. Loosen the butterfly screw (Figure 13).
2. Turn the grip clockwise to raise the handle or counterclockwise to lower the handle.
3. When the handle is raised to the desired height, tighten the butterfly screw.

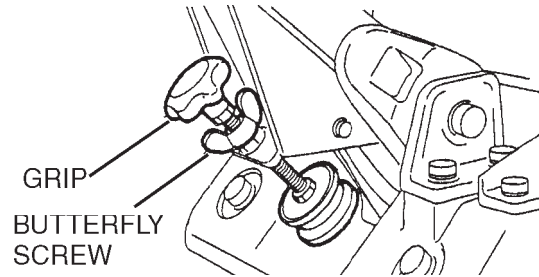

Figure 13. Handle Adjustment

## STARTING THE ENGINE

### Starting the Engine (HONDA engine)

1. Place the engine **fuel valve lever** (Figure 14) to the "ON" position.

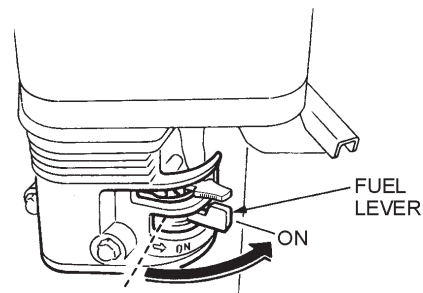

Figure 14. Engine Fuel Valve Lever (ON Position)

2. Move the throttle lever to the **START** position (Figure 15).

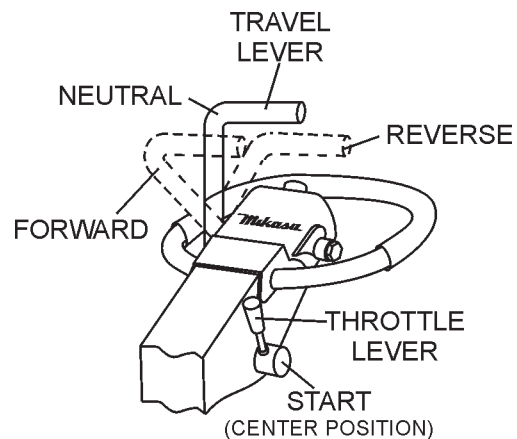
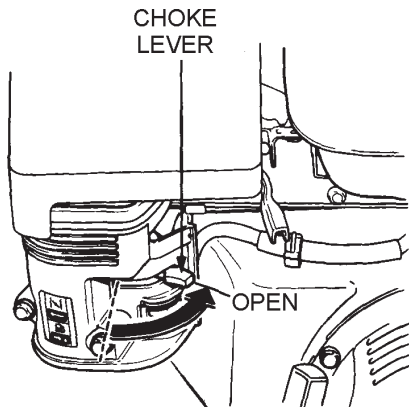

Figure 15. Throttle Lever (Start Position)

- Place the **choke lever** (Figure 16) in the "**OPEN**" position if starting a **cold engine**.



**Figure 16. Engine Choke Lever (Open)**

- Place the **choke lever** (Figure 17) in the "**CLOSED**" position if starting a **warm engine** or the **temperature is warm**.

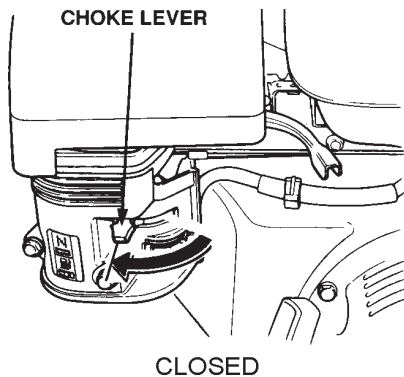

**Figure 17. Engine Choke Lever (Closed)**

- Place the **engine ON/OFF switch** (Figure 18) in the "**ON**" position.

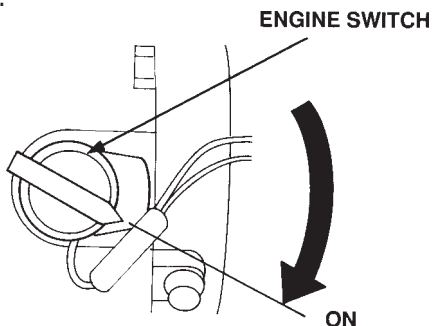

**Figure 18. Engine ON/OFF Switch (ON Position)**

- Grasp the starter grip (Figure 19) and slowly pull it out. The resistance becomes the hardest at a certain position, corresponding to the compression point. Pull the starter grip briskly and smoothly for starting.

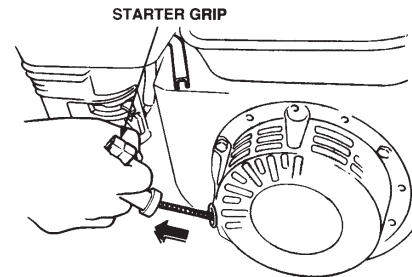
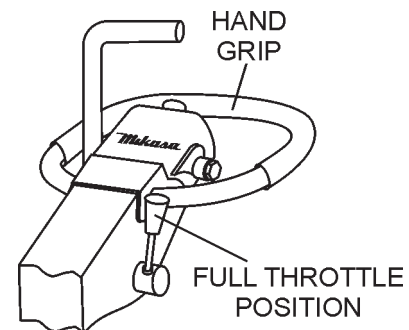

**Figure 19. Starter Grip**

- If the engine has started, slowly return the choke lever (Figure 17) to the **CLOSED** position. If the engine has not started repeat steps 1 through 6.
- Before the compactor is placed into operation, run the engine for several minutes. Check for fuel leaks, and noises that would be associated with a loose component.

## TRAVELING

- Grasp the compactor's hand grip (Figure 20), and move the engine throttle lever (Figure 20) quickly to the **fast** position.
- With the throttle lever in the fast position, the engine speed should be around 3,600 RPM, therefore engaging the centrifugal clutch.

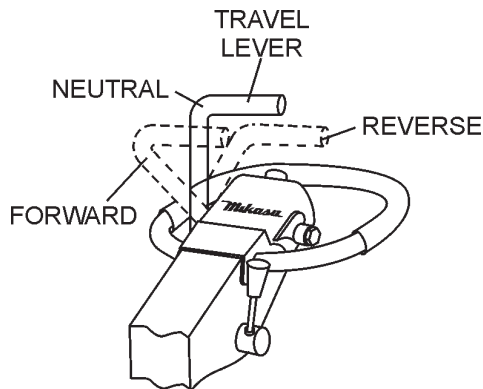

**Figure 20. Throttle Lever (Fast)**

### NOTICE

**ALWAYS** move the throttle lever quickly without hesitation, because increasing the engine speed slowly causes the clutch to slip.

- To make the compactor move in the forward direction push the travel lever ( Figure 21) forward.

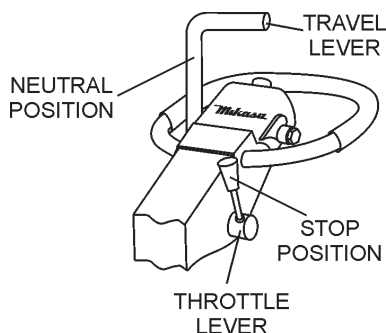

**Figure 21. Travel Lever**

- To make the compactor move in the reverse direction pull the travel lever ( Figure 21) backwards.
- Firmly grasp the compactor's hand grip, the compactor will begin moving in the desired position when the direction lever has been placed in the desired position.
- Slowly walk behind the compactor and be on the lookout for any large objects or foreign matter that might cause damage to the compactor or bodily injury.
- If travel lever is placed in the neutral position, the machine will vibrate in place.
- To move the compactor laterally, hold the hand grip firmly and swing compactor. **DO NOT** swing compactor while gripping the travel lever.

### Normal Shutdown

- Return the throttle lever to the **START** position (Figure 15). Allow the machine to cool down for 2 to 3 minutes.
- Place the travel lever in the **NEUTRAL** position.
- Place the throttle lever in the **STOP** position (Figure 22) to stop the engine.
- Turn the engine ON/OFF switch to the "**OFF**" position (Figure 23).
- Place the **fuel shut-off lever** (Figure 24) in the **OFF** position.



**Figure 22. Throttle Lever (Stop)**

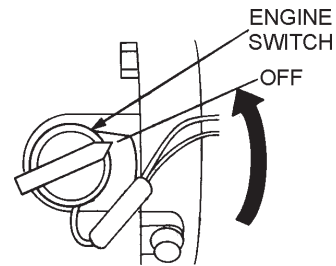

**Figure 23. Engine ON/OFF Switch (OFF)**

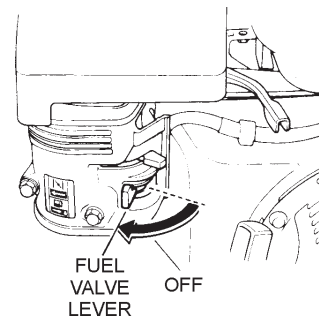

**Figure 24. Fuel Valve Lever (OFF)**

### Emergency Shutdown

- For a recoil start type engine, move the throttle lever quickly to the **STOP** position.

### STOWING THE HANDLE

- Push up the handle upward (Figure 25) until the handle locks in place.

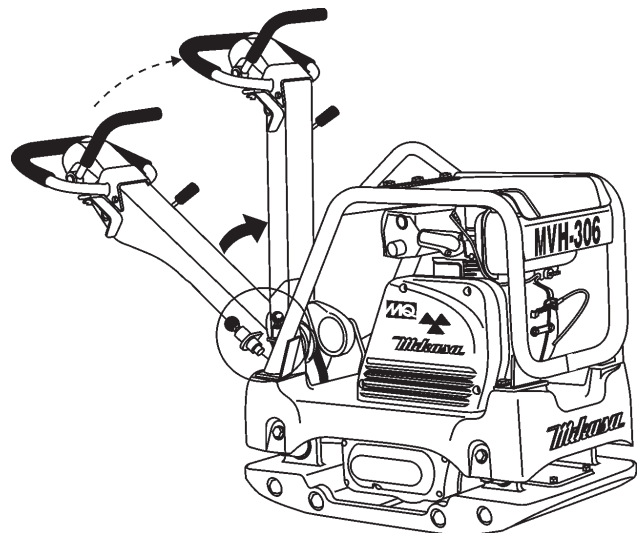

**Figure 25. Stowing the Handle**

Inspection and other services should **always** be carried out on hard and level ground with the engine shut down.

## Inspection and Maintenance Service Tables.

- To make sure your plate compactor is always in good working condition before using, carry out the maintenance inspection in accordance with Tables 5 through 7.

**TABLE 5. MVH-306GH MACHINE INSPECTION**

ITEM	HOURS OF OPERATION	REMARKS
Loose or Missing Screws	Every 8 hours (every day)	
Damaged Parts	Every 8 hours (every day)	
Function of Controlling System Part	Every 8 hours (every day)	
Hydraulic System Leak	Every 100 hours	See page 21
Vibrator Oil Check	Every 100 hours	See page 23
Vibrator Oil Replacement	Every 300 hours	See page 23
Hydraulic Oil Check	Every 100 hours	See page 23
Hydraulic Oil Replacement	First after 200 hours, then every 1,000 hours	See page 23
V-belt (clutch) Check	Every 200 hours	See page 22
Battery Check	Every 100 hours	See page 24

### NOTICE

These inspection intervals are for operation under normal conditions. Adjust your inspection intervals based on the number hours plate compactor is in use, and particular working conditions.

### NOTICE

Fuel piping and connections should be replaced every 2 years.

**TABLE 6. MVH-306GH Engine Check**

ITEM	HOURS OF OPERATION
Spark Plug Check	Every 40 hours (every week)
Oil or Fuel Leak	Every 8 hours (every day)
Tightness of Fastening Threads	Every 8 hours (every day)
Engine Oil Check and Replenishment	Every 8 hours (every day) (Replenish to specified maximum level)
Engine Oil Replacement	After first 25 hours then every 50 to 100 hours
Air Filter Cleaning	Every 100 hours
See separate engine manual for details on engine check.	

### Daily Service

- Check for leakage of fuel or oil.
- Check for loose screws including tightness. See Table 7 below (tightening torque), for retightening:

**TABLE 7. TIGHTENING TORQUE (in. kg/cm) Diameter**

Material	6mm	8mm	10mm	12mm	14mm	16mm	18mm	20mm
4T	70	150	300	500	750	1,100	1,400	2,000
6-8T	100	250	500	800	1,300	2,000	2,700	3,800
11T	150	400	800	1,200	2,000	2,900	4,200	5,600
*	100	300~350	650~700					

\* (In case counter-part is of aluminum)  
(Threads in use with this machine are all right handed)  
Material and quality of material is marked on each bolt, and screw.

- Remove soil and clean the bottom of compaction plate.
- Check hand pump, piping and hose for any leakage. A loosened hydraulic hose can be a cause for leakage. Check hydraulic hose connections with wrench applied for tightness.
- Check engine oil.

## Spark Plug

1. Remove and clean the spark plug (Figure 26).
2. Adjust the spark gap to 0.028 ~0.031 inch (0.6~0.7 mm). This unit has electronic ignition, which requires no adjustments.

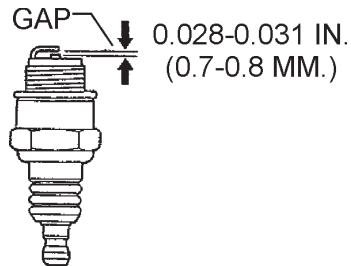

Figure 26. Spark Plug Gap

## Engine Oil Replacement

1. Replace engine oil, first in 25 hours of operation and every 50 to 100 hours afterwards.
2. Drain the engine oil when the oil is **warm** as shown in Figure 27.
3. Remove the oil drain bolt and sealing washer and allow the oil to drain into a suitable container.
4. Replace engine oil with recommended type oil as listed in Table 4. Engine oil capacity is 1.16 quarts (1.1 liters). **DO NOT** overfill.
5. Install drain bolt with sealing washer and tighten securely.

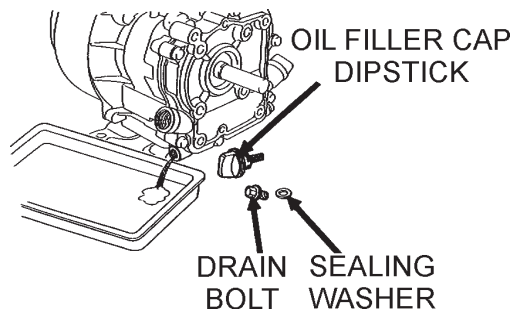

Figure 27. Engine Oil (Draining)

## Air Filter

1. Remove the air cleaner cover and foam filter element as shown in Figure 28.
2. Tap the paper filter element (Figure 28) several times on a hard surface to remove dirt, or blow compressed air [not exceeding 30 psi (207 kPa, 2.1 kgf/cm<sup>2</sup>)] through the filter element from the air cleaner case side. **NEVER** brush off dirt. Brushing will force dirt into the fibers. Replace the paper filter element if it is excessively dirty.
3. Clean foam element in warm, soapy water or nonflammable solvent. Rinse and dry thoroughly. Dip the element in clean engine oil and completely squeeze out the excess oil from the element before installing.

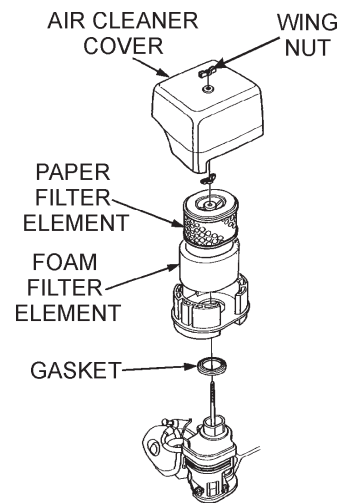

Figure 28. Engine Air Filter

## CAUTION

**NEVER** attempt to check the V-belt with the engine running. Severe injury can occur if your hand gets caught between the V-belt and the clutch (Figure 29). Always use safety gloves.

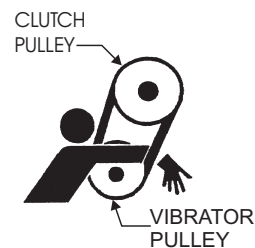

Figure 29. V-Belt Hazard

## Checking and Replacing the V-Belt and Clutch

- After 200 hours of operation, remove the belt cover to check the V-belt tension (Figure 30). Tension is proper if the belt bends about 3/8" (10 mm) when depressed strongly with finger between shafts. Loose or worn V-belts reduces power transmission efficiency, causing weak compaction and reduces the life of the belt itself.

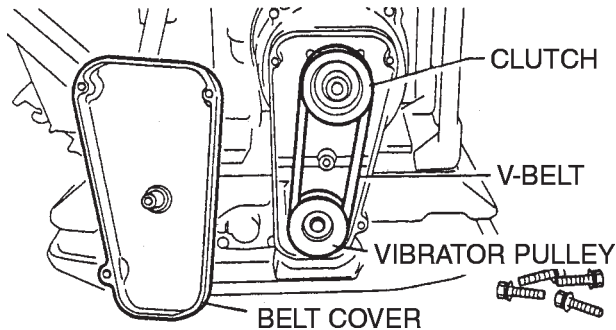

Figure 30. V-Belt Check

### ● Replacing the V-belt

Remove the belt cover. Engage an offset wrench 3/4" (19 mm) or the like to vibrator pulley (lower) fastening bolt. Engage waste cloth or the like at midway of V-belt on the left side and while pulling it back strongly, rotate the offset wrench clockwise so that the V-belt will come off.

### ● Reinstalling the V-belt

Engage V-belt to lower vibrator pulley and push the V-belt to left side of upper clutch and, in the same manner as in removal, rotate offset wrench clockwise so that the V-belt goes back on.

### ● Checking Clutch

Check the clutch simultaneously with V-belt checking. With belt cover removed, check outer drum of the clutch for seizure and "V" groove for wear or damage with your eyes. Clean the "V" groove as necessary. Wear of lining or shoe should be checked with running check. If the shoe is worn, power transmission becomes deficient and slipping will result.

### ● Replacing Clutch

Remove V-belt. Remove bolt at engine power output by giving a shock to an engaged wrench (tapping with hammer or the like) and rotating bolt counterclockwise. Remove clutch with a pulley extractor. To reinstall, reverse the procedure.

### ⚠ CAUTION

Whenever the compactor's vibration becomes weak or lost during normal operation regardless of operation hours, check the V-belt and clutch immediately.

## Vibrator Oil Level Check

### NOTICE

Always clean the area around the vibrator oil level check plug before removing oil check plug. This will prevent dirt and debris from entering the system.

- In every 100 hours of operation, with the machine positioned horizontally, use a 3/4" (19 mm) wrench and remove vibrator oil level check plug (Figure 31). Visually inspect and see if vibrator oil level is up to filler port. Be sure to clean area around check hole to prevent dirt and dust from entering.

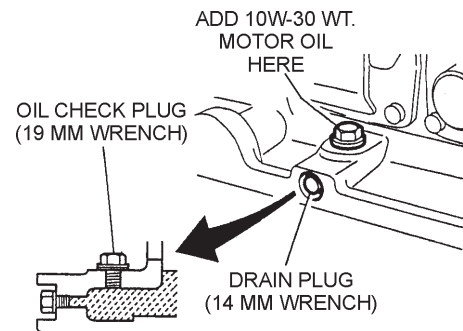

Figure 31. Vibrator Oil Drain and Check Plugs

## Draining Vibrator Oil

- Replace vibrator oil after first 200 hours and in every 1,000 hours of operation.
- Position handle bar vertically (storage position).
- Using a 14 mm wrench remove the vibrator oil drain plug (Figure 31) from the vibrating plate assembly.

### NOTICE

For draining oil through level check hole, have the machine inclined with a sleeper or the like placed under the compaction plate on opposite side.

- After vibrator oil has been completely drained from machine, fill with 10W-30 motor oil to the appropriate safe operating level (Figure 31).
- Reinstall drain plug into vibrating plate assembly. Apply seal tape or Loctite #575 to thread portion of drain plug.

## Draining Hydraulic Oil

- Disconnect the hydraulic hose connected to the hydraulic oil cylinder (Figure 32).

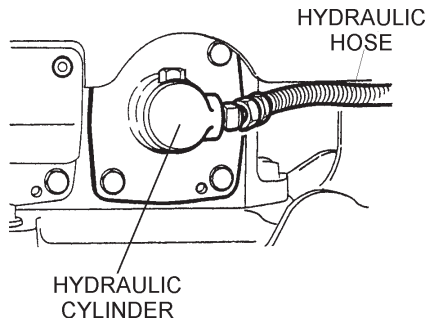
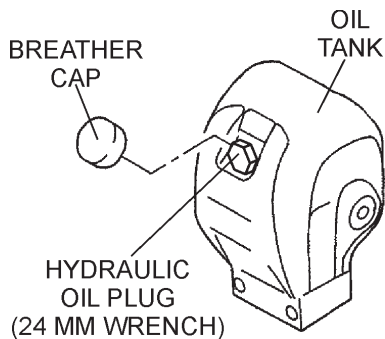

**Figure 32. Hydraulic Oil Cylinder**

2. Push the travel lever back and forth to drain the hydraulic oil from the hand pump (hydraulic oil reservoir).
3. After draining hydraulic oil, reconnect hydraulic oil hose to cylinder.
4. Place handle in upright position. Pull travel lever all the way back (reverse), and using a rope, secure travel lever to hand grip.

### Adding Hydraulic Oil

1. Remove the breather cap and oil plug (Figure 33) from the hydraulic oil tank using a 24mm hex socket.



**Figure 33. Hydraulic Oil Tank**

2. Using a funnel, add **ShellTellus Oil #46** or equivalent to the hydraulic oil tank through the oil filler port (Figure 34). Oil tank capacity is 50.7 fl. oz (1500 cc)

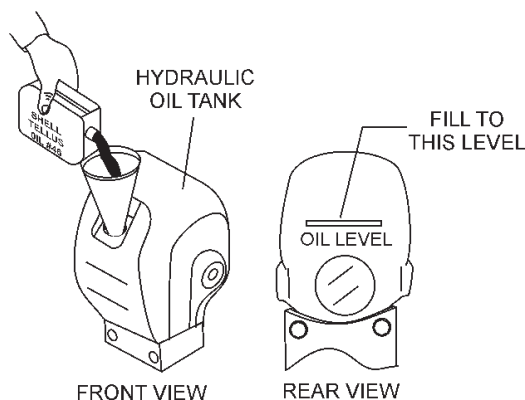
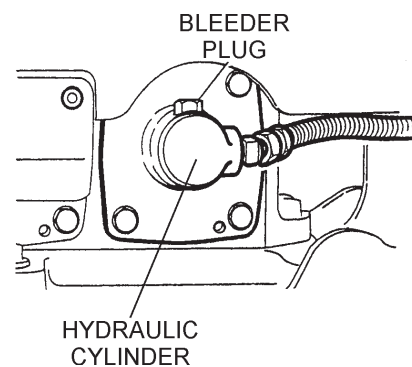

**Figure 34. Hydraulic Oil Maintenance**

### **CAUTION**

Make sure hydraulic oil is at a normal safe operating level. **DO NOT** over fill. Over filling (excessive oil) will cause excess oil to blow out of breather plug.

3. Loosen bleeder plug located at top of hydraulic cylinder on side of vibrator (Figure 35). Air remaining in the circuit will be forced out of the bleeder plug. Once all air has been purged from the hydraulic system, tighten bleeder plug securely
4. Re-insert oil plug into hydraulic oil tank and tighten securely. Re-install breather cap.



**Figure 35. Bleeder Plug**

### LONG TERM STORAGE

When storing your compactor for long periods do the following:

- Run the engine at idle speed for 3-5 minutes.
- Stop the engine. Drain the engine crankcase oil while the engine is still warm. Fill engine crankcase with fresh oil.
- Wipe any oil or dirt that may have accumulated on the compactor.
- Store compactor in a cool dry place out of reach of children and unauthorized personnel.

### Troubleshooting

See Tables 8 (engine) and 9 (plate compactor) on proceeding pages for engine and plate compactor troubleshooting guide.

# TROUBLESHOOTING

Practically all breakdowns can be prevented by proper handling and maintenance inspections, but in the event of a breakdown, please take a remedial action following the

diagnosis based on the Engine Troubleshooting (Table 8) information shown below. If the problem cannot be remedied, please leave the unit just as it is and consult our company's business office or service plant.

**TABLE 8. ENGINE TROUBLESHOOTING**

SYMPTOM	POSSIBLE CAUSE	SOLUTION
Difficult to start, "fuel is available, but no SPARK at spark plug".	Spark plug bridging?	Check gap, insulation or replace spark plug.
	Carbon deposit on spark plug?	Clean or replace spark plug.
	Short circuit due to deficient spark plug insulation?	Check spark plug insulation, replace if worn.
	Improper spark plug gap?	Set to proper gap.
Difficult to start, "fuel is available, and SPARK is present at the spark plug".	ON/OFF switch is shorted?	Check switch wiring, replace switch.
	Ignition coil defective?	Replace ignition coil.
	Improper spark gap, points dirty?	Set correct spark gap and clean points.
	Condenser insulation worn or short circuiting?	Replace condenser.
	Spark plug wire broken or short circuiting?	Replace defective spark plug wiring.
Difficult to start, "fuel is available, spark is present and compression is normal"	Wrong fuel type?	Flush fuel system, and replace with correct type of fuel.
	Water or dust in fuel system?	Flush fuel system.
	Air cleaner dirty?	Clean or replace air cleaner.
Difficult to start, "fuel is available, spark is present and compression is low"	Suction/exhaust valve stuck or protruded?	Re-seat valves.
	Piston ring and/or cylinder worn?	Replace piston rings and or piston.
	Cylinder head and/or spark plug not tightened properly?	Torque cylinder head bolts and spark plug.
	Head gasket and/or spark plug gasket damaged?	Replace head and spark plug gaskets.
No fuel present at carburetor.	Fuel not available in fuel tank?	Fill with correct type of fuel.
	Fuel cock does not open properly?	Apply lubricant to loosen fuel cock lever, replace if necessary.
	Fuel filter clogged?	Replace fuel filter.
	Fuel tank cap breather hole clogged?	Clean or replace fuel tank cap.
	Air in fuel line?	Bleed fuel line.

**TABLE 8. ENGINE TROUBLESHOOTING (CONTINUED)**

SYMPTOM	POSSIBLE CAUSE	SOLUTION
"Weak in power" compression is proper and does not misfire.	Air cleaner not clean?	Clean or replace air cleaner
	Improper level in carburetor?	Check float adjustment, re-build carburetor.
	Defective Spark plug?	Clean or replace spark plug.
	Defective Spark plug?	
"Weak in power" compression is proper but misfires.	Water in fuel system?	Flush fuel system, and replace with correct type of fuel.
	Dirty spark plug?	Clean or replace spark plug.
	Ignition coil defective?	Replace ignition coil.
Engine overheats.	Spark plug heat value improper?	Replace with correct type of spark plug.
	Correct type of fuel?	Replace with correct type of fuel
	Cooling fins dirty?	Clean cooling fins.
Rotational speed fluctuates.	Governor adjusted correctly?	Adjust governor.
	Governor spring defective?	Replace governor spring.
	Fuel flow restricted?	Check entire fuel system for leaks or clogs.
Recoil starter malfunction.	Recoil mechanism clogged with dust and dirt?	Clean recoil assembly with soap and water.
	Spiral spring loose?	Replace spiral spring.

# TROUBLESHOOTING

Practically all breakdowns can be prevented by proper handling and maintenance inspections, but in the event of a breakdown, please take a remedial action following the

diagnosis based on the Compactor Troubleshooting (Table 9) information shown below. If the problem cannot be remedied, please leave the unit just as it is and consult our company's business office or service plant.

TABLE 9. TROUBLESHOOTING COMPACTOR		
SYMPTOM	POSSIBLE CAUSE	SOLUTION
Travel speed low and vibration weak.	Clutch slips?	Adjust or replace clutch.
	V-belt slips?	Adjust or replace V-belt.
	Excessive Oil in vibrator?	Fill to correct level..
	Trouble in vibrator internals?	Check vibrator assembly for any worn or defective parts, replace any defective parts.
	Aeration in hydraulic oil for for travel reversing syste.?	Purge air in hydraulic oil. (Bleed plug)
	Engine speed incorrect?	Set engine speed to correct RPM.
Travels forward or backward but unable to switch direction.	Travel reversing system inoperative.?	Check entire travel system.
	Reversing lever installation correct?	Clean installation of reversing lever.
	Broken or defective oil hose?	Replace oil hose.
	Aeration in hydraulic oil for for travel reversing syste.?	Purge air in hydraulic oil. (Bleed plug)
	Excessive oil in reversing system?	Fill to correct level..
	Selector valve clogged with trash?	Clean selector valve.
	Cylinder piston bearing failure?	Check piston bearing in cylinder for leakage at USH packing.
Does not travel in forward or reverse.	V-belt dis-engaged or slips?	Engage V-belt, adjust or replace.
	Clutch slips?	Adjust clutch, replace if necessary.
	Pump input shat key or adapter key-way damaged?	Replace input shatkey or adapter key-way
	Cylinder piston bearing failure?	Check piston bearing in cylinder for leakage at USH packing.
Reversing lever operating resistance great.	Excessive hydraulic oil?	Fill to correct level.

# EXPLANATION OF CODE IN REMARKS COLUMN

The following section explains the different symbols and remarks used in the Parts section of this manual. Use the help numbers found on the back page of the manual if there are any questions.

## NOTICE

The contents and part numbers listed in the parts section are subject to change **without notice**. Multiquip does not guarantee the availability of the parts listed.

## SAMPLE PARTS LIST

NO.	PART NO.	PART NAME	QTY.	REMARKS
1	12345	BOLT.....	1	INCLUDES ITEMS W/%
2%		WASHER, 1/4 IN.....		NOT SOLD SEPARATELY
2%	12347	WASHER, 3/8 IN....	1	MQ-45T ONLY
3	12348	HOSE .....		A/R ...MAKE LOCALLY
4	12349	BEARING .....	1	S/N 2345B AND ABOVE

## NO. Column

**Unique Symbols** — All items with same unique symbol

(@, #, +, %, or >) in the number column belong to the same assembly or kit, which is indicated by a note in the “Remarks” column.

**Duplicate Item Numbers** — Duplicate numbers indicate multiple part numbers, which are in effect for the same general item, such as different size saw blade guards in use or a part that has been updated on newer versions of the same machine.

## NOTICE

When ordering a part that has more than one item number listed, check the remarks column for help in determining the proper part to order.

## PART NO. Column

**Numbers Used** — Part numbers can be indicated by a number, a blank entry, or TBD.

TBD (To Be Determined) is generally used to show a part that has not been assigned a formal part number at the time of publication.

A blank entry generally indicates that the item is not sold separately or is not sold by Multiquip. Other entries will be clarified in the “Remarks” Column.

## QTY. Column

**Numbers Used** — Item quantity can be indicated by a number, a blank entry, or A/R.

A/R (As Required) is generally used for hoses or other parts that are sold in bulk and cut to length.

A blank entry generally indicates that the item is not sold separately. Other entries will be clarified in the “Remarks” Column.

## REMARKS Column

Some of the most common notes found in the “Remarks” Column are listed below. Other additional notes needed to describe the item can also be shown.

**Assembly/Kit** — All items on the parts list with the same unique symbol will be included when this item is purchased.

Indicated by:

“INCLUDES ITEMS W/(unique symbol)”

**Serial Number Break** — Used to list an effective serial number range where a particular part is used.

Indicated by:

“S/N XXXXX AND BELOW”

“S/N XXXX AND ABOVE”

“S/N XXXX TO S/N XXX”

**Specific Model Number Use** — Indicates that the part is used only with the specific model number or model number variant listed. It can also be used to show a part is NOT used on a specific model or model number variant.

Indicated by:

“XXXXX ONLY”

“NOT USED ON XXXX”

**“Make/Obtain Locally”** — Indicates that the part can be purchased at any hardware shop or made out of available items. Examples include battery cables, shims, and certain washers and nuts.

**“Not Sold Separately”** — Indicates that an item cannot be purchased as a separate item and is either part of an assembly/kit that can be purchased, or is not available for sale through Multiquip.

## SUGGESTED SPARE PARTS

---

### **MVH-306 WITH HONDA GX270K1SMX2 ENGINE**

*1 to 3 Units*

Qty...	P/N .....	Description
1 .....	956100055 .....	THROTTLE WIRE
2 .....	070200363 .....	V-BELT
3 .....	9807955846 .....	SPARK PLUG
3 .....	17210ZE2822 .....	ELEMENT, AIR CLEANER (DUAL)
1 .....	17620Z0T814 .....	CAP, FUEL TANK
1 .....	28462ZE2W11 .....	ROPE, RECOIL

# NAMEPLATE AND DECALS

## NAMEPLATE AND DECALS

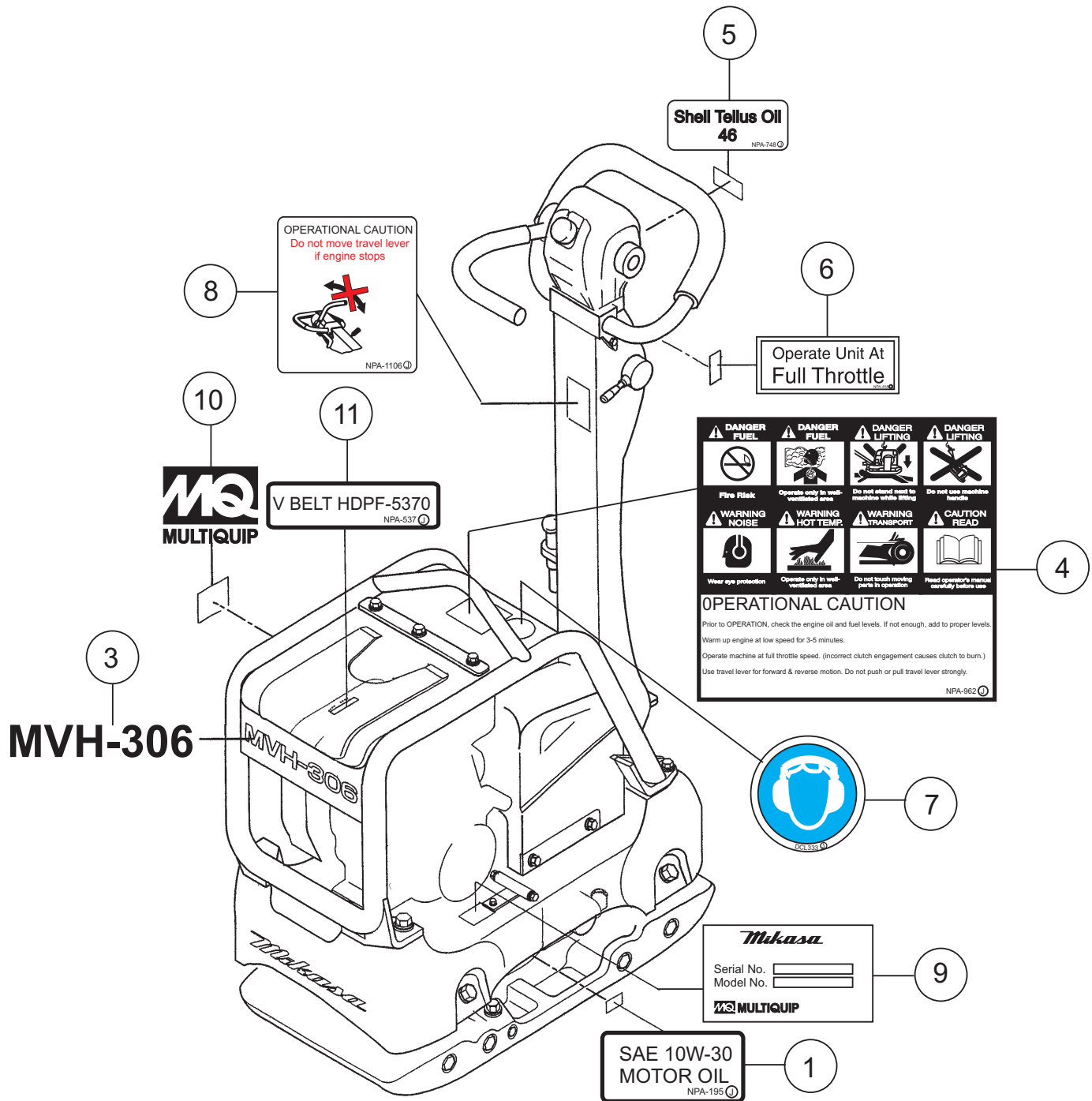

## NAMEPLATE AND DECALS

---

### NAMEPLATE AND DECALS

<u>NO.</u>	<u>PART NO.</u>	<u>PART NAME</u>	<u>QTY.</u>	<u>REMARKS</u>
1	920201950	DECAL: OIL SAE 10W-30 .....	1 .....	NPA-195
3	920110370	DECAL: MODEL LOGO	1	
4	920209620	DECAL: CAUTION .....	1 .....	NPA-962
5	920207480	DECAL: SHELL TELLUS OIL 46 .....	1 .....	NPA-748
6	920204580	DECAL: FULL THROTTLE .....	1 .....	NPA-458
7	920203330	DECAL: EAR PROTECTION .....	1 .....	DCL333
8	920211060	DECAL: CAUTION (TRAVEL LEVER) .....	1 .....	NPA-1106
9		DECAL: SERIAL NO. ....	1 .....	CONTACT MQ PARTS DEPT.
10	920201580	DECAL: MQ LOGO	1	
11	920211010	DECAL: V-BELT HDPF-5370 .....	1 .....	NPA-537

# VIBRATING PLATE ASSY.

VIBRATING PLATE ASSY.

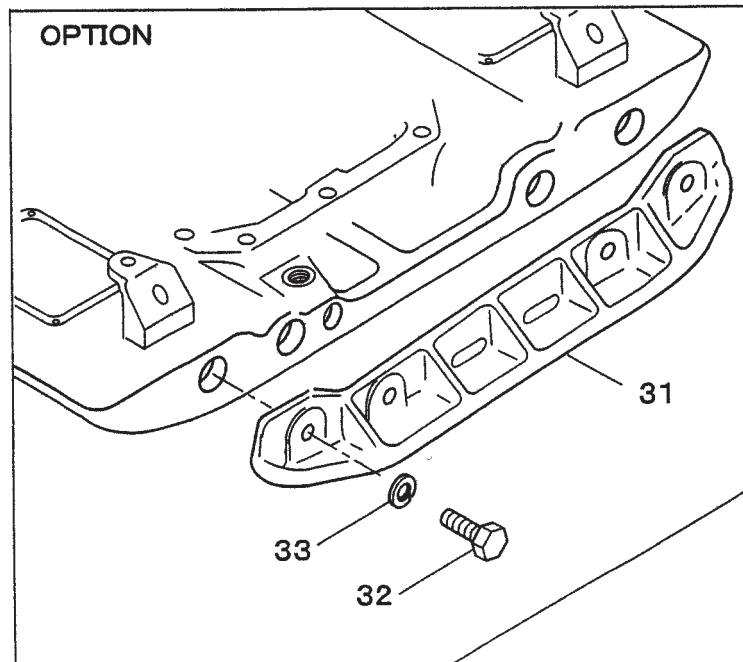
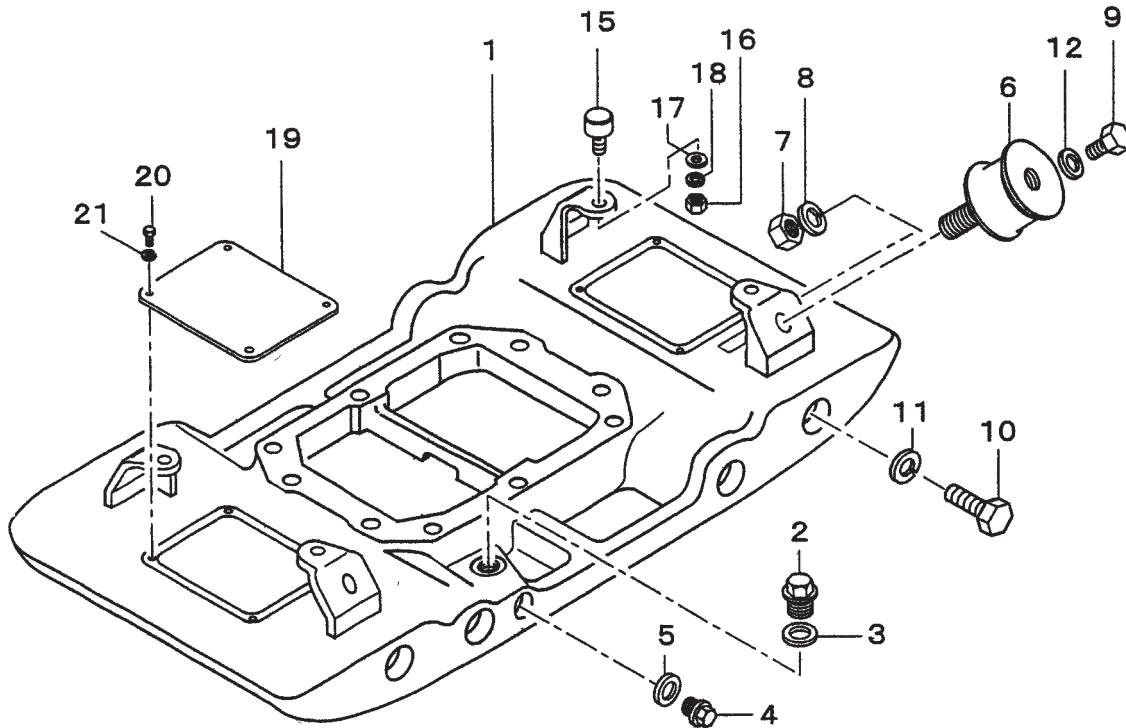

## VIBRATING PLATE ASSY.

---

### VIBRATING PLATE ASSY.

<u>NO.</u>	<u>PART NO.</u>	<u>PART NAME</u>	<u>QTY.</u>	<u>REMARKS</u>
1	464117840	VIBRATING PLATE	1	
2	953405840	DRAIN PLUG M18 (H)	1	
3	953402930	COPPER PACKING 19X30X1	1	
4	953400270	PLUG 1/4X14 10L	1	
5	953405260	PACKING 1/4 (CU)	1	
6	939010260	SHOCK ABSORBER 110X60H	4	
7	020316130	NUT M16	4	
8	030216400	WASHER, LOCK M16	4	
9	001221635	BOLT 16X35 T	4	
10	001221830	BOLT 18X30 T	8	
11	58407	WASHER, LOCK M18	8	
12	030216400	WASHER, LOCK M16	4	
15	939010010	SHOCK ABSORBER, STOPPER 45	4	
16	020310080	NUT M10	4	
17	031110160	WASHER, FLAT M10	4	
18	030210250	WASHER, LOCK M10	4	
19	464343730	COVER, VIBRATING PLATE	2	
20	011008015	BOLT 8X15 T	8	
21	030208200	WASHER, LOCK M8	8	
31	52993	EXTENSION PLATE	2	
32	012218050	BOLT 18X50 T	8	
33	58407	WASHER, LOCK M18	8	

# BASE AND ENGINE ASSY.

## BASE AND ENGINE ASSY.

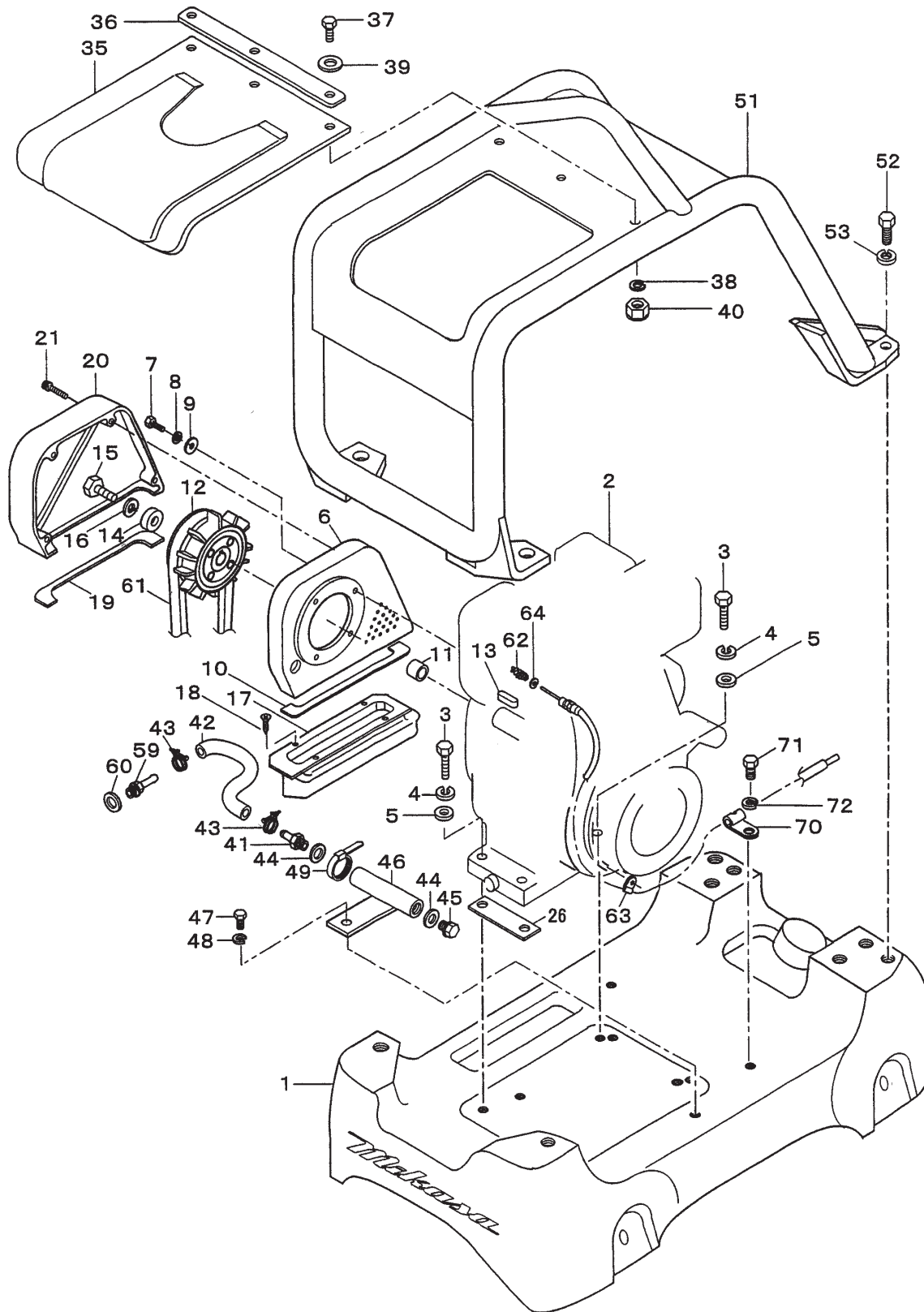

## BASE AND ENGINE ASSY.

### BASE & ENGINE ASSY.

<u>NO.</u>	<u>PART NO.</u>	<u>PART NAME</u>	<u>QTY.</u>	<u>REMARKS</u>
1	464117850	BASE	1	
2	912227003	ENGINE ASSY., GX270K1SMX2 (HONDA)	1	
3	0105051045	BOLT 10X45 T	4	
4	030210250	WASHER, LOCK M10	4	
5	031110160	WASHER, FLAT M10	4	
6	464216580	BELT COVER (IN)	1	
7	001121025	BOLT 8X25 T	4	
8	030210250	WASHER, LOCK M10	4	
9	031110160	WASHER, FLAT M10	4	
10	464343670	DUST-PROOF SPONGE (IN)	1	
11	464457360	SPACER	1	
12	456343340	CLUTCH ASSY./CHM03/W.FAN	1	
13	951400110	KEY 7X7X35	1	
14	952400690	WASHER 9X35X4.5	1	
15	001220830	BOLT 8X30 T	1	
16	030208200	WASHER, LOCK M8	1	
17	464216640	DUST-PROOF COVER	1	
18	092006010	FLAT HEAD SCREW 6X10	3	
19	464343660	DUST-PROOF SPONGE (OUT)	1	
20	464216590	BELT COVER (OUT)	1	
21	001521050	SOCKET HEAD BOLT 10X50 T	4	
26	464457430	SPACER, ENGINE	2	
35	464117920	RUBBER COVER (GUARD FRAME)	1	
36	456449950	PLATE, COVER	1	
37	011208030	BOLT 8X30 T	1	
38	030208200	WASHER, LOCK M8	3	
39	031108160	WASHER, FLAT M8	3	
40	022710809	NYLON NUT M8	3	

# BASE AND ENGINE ASSY.

## BASE AND ENGINE ASSY. (CONTINUED)

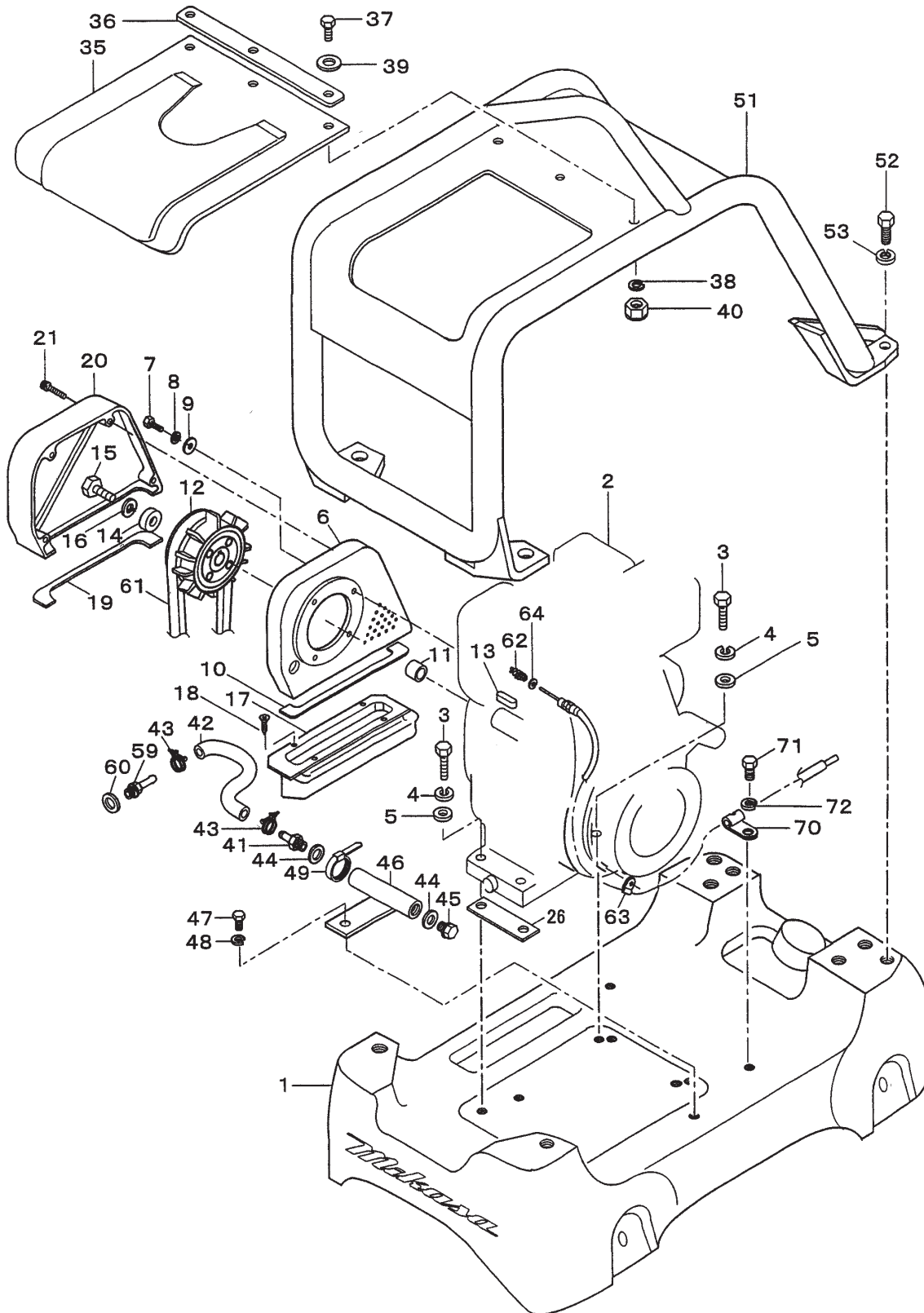

## BASE AND ENGINE ASSY.

---

### BASE AND ENGINE ASSY. (CONTINUED)

<u>NO.</u>	<u>PART NO.</u>	<u>PART NAME</u>	<u>QTY.</u>	<u>REMARKS</u>
41	459010060	UNION TIP, DRAIN	1	
42	459010070	DRAIN HOSE	1	
43	459010090	HOSE BAND	2	
44	459010080	GASKET(OIL DRAIN)	2	
45	0401140030	PLUG	1	
46	464457380	DRAIN JOINT	1	
47	014208020	BOLT 8X20 T	1	
48	030208200	WASHER, LOCK M8	1	
51	464117900	GUARD HOOK	1	
52	012214030	BOLT 14X30 T	4	
53	030214350	WASHER, LOCK M14	4	
59	90131ZE3790	DRAIN JOINT	1	
60	9410912000	WASHER, DRAIN PLUG M12	1	
61	070200363	V-BELT	1	
62	0830000010	COIL SPRING	1	
63	151010680	CLAMP CP.	1	
64	58151	WASHER, FLAT M5	1	
70	959407260	CLIP D6 (FOR M10)	1	
71	001221015	BOLT 10X15 T	1	
72	030210250	WASHER, LOCK M10	1	

# VIBRATOR ASSY.

## VIBRATOR ASSY.

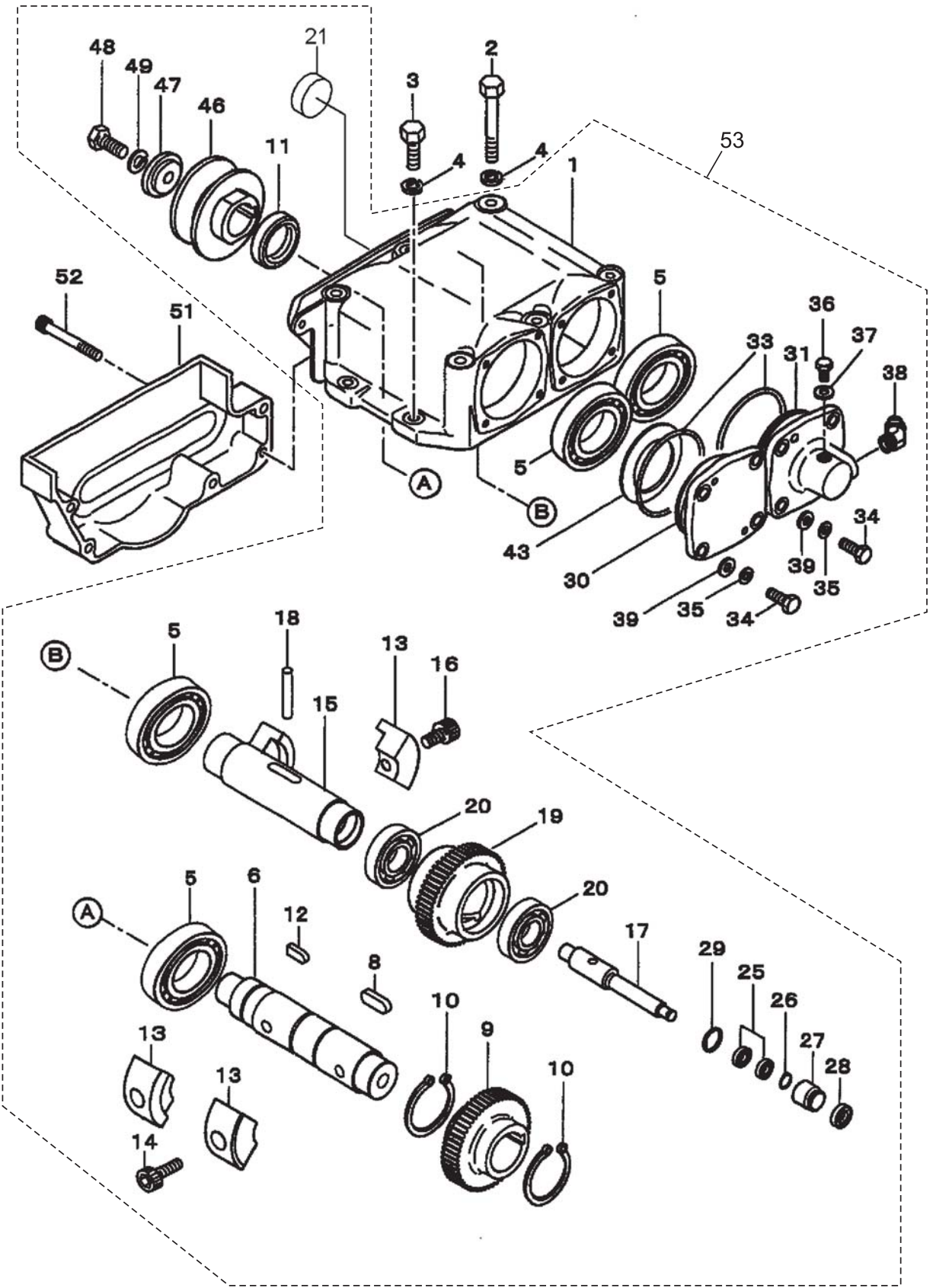

# VIBRATOR ASSY.

## VIBRATOR ASSY.

<u>NO.</u>	<u>PART NO.</u>	<u>PART NAME</u>	<u>QTY.</u>	<u>REMARKS</u>
1#	464117880	VIBRATING CASE	1	
2	001221470	BOLT 14X150 T	6	
3	001221450	BOLT 14X50 T	4	
4	030214350	WASHER, LOCK M14	10	
5#	047920120	ROLLER BEARING NJ310EMC4	4	
6#	457212410	ROTARY SHAFT, DRIVE	1	
8#	951405370	KEY 15X10X39 RR	1	
9#	456327150	GEAR, DRIVE	1	
10#	080200550	STOP RING S-55	2	
11#	060105030	OIL SEAL SB-50729	1	
12#	951404970	KEY 12X8X30 R	1	
13#	464343700	ECCENTRIC ROTATOR	4	
14#	009120301	SOCKET HEAD BOLT 16X40 T	2	
15#	456337670	ROTARY SHAFT, DRIVEN	1	
16#	009120302	SOCKET HEAD BOLT 16X30 T	2	
17#	456337380	PISTON ROD	1	
18#	456010010	KNOCK PIN 10X70	1	
19#	464343720	GEAR (DRIVEN)	1	
20#	040006911	BEARING 6911	2	
21#	953010030	SEAL CAP/SC72-8N	1	
25#	042506000	BEARING 6000ZZSG	2	
26#	080200100	STOP RING S-10	1	
27#	455435051	PISTON, 22.4D	1	
28#	455010070	PACKING USH-22.4X30X5	1	
29#	080100260	STOP RING R-26	1	
30#	456327130	BEARING COVER	1	
31#	456210636	CYLINDER (L)/(AC)	1	
33#	050101050	O-RING G-105	2	
34#	0012221025	BOLT 10X25 T	8	
35#	030210250	WASHER, LOCK M10	8	
36#	011008015	BOLT 8X12 T	1	
37#	953404600	COPPER PACKING 8X16X2	1	
38#	455010020	ELBOW 45 DEG. 15-0404	1	
39#	031110160	WASHER, FLAT M10	4	
43#	952405470	SHIM 90X110X0.5	2	
46#	464343710	PULLEY	1	
47#	464457370	WASHER	1	
48#	012212030	BOLT 12X30 T	1	
49#	030212300	WASHER, LOCK M12	1	
51	464216600	BELT COVER (LOWER)	1	
52	001520852	SOCKET HEAD BOLT 8X60 T	5	
53	464910020	VIBRATOR ASSY .....	1	INCLUDES ITEMS W/#

# CONTROL HANDLE ASSY.

## CONTROL HANDLE ASSY.

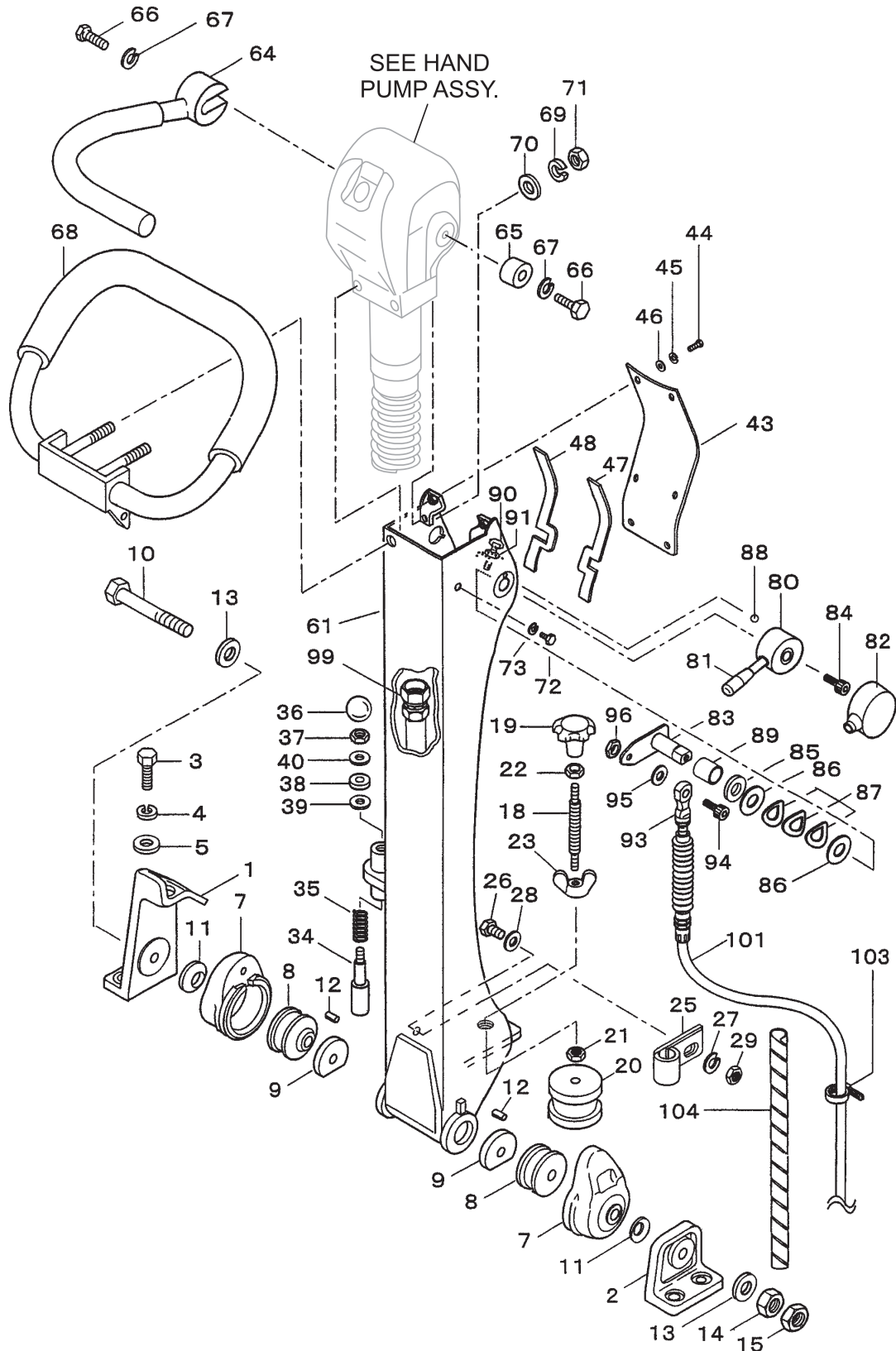

## CONTROL HANDLE ASSY.

### CONTROL HANDLE ASSY.

<u>NO.</u>	<u>PART NO.</u>	<u>PART NAME</u>	<u>QTY.</u>	<u>REMARKS</u>
1	464343680	HANDLE BRACKET	1	
2	456336420	HANDLE BRACKET (R)	1	
3	012212035	BOLT 12X35 T	4	
4	030212300	WASHER, LOCK M12	4	
5	031112230	WASHER, FLAT M12	4	
7	456336400	RUBBER COUPLING	2	
8	456449940	SHOCK ABSORBER	2	
9	456449930	RUBBER PLATE	2	
10	001221681	BOLT 16X250 T	1	
11	032124400	CONICAL SPRING WASHER M24	2	
12	025306016	SPRING PIN 6X16	2	
13	0401450160	WASHER, FLAT M16	2	
14	020316130	NUT M16	1	
15	020416100	NUT M16, H=10	1	
18	455434950	SPINDLE	1	
19	455010030	KNOB	1	
20	939010060	SHOCK ABSORBER	1	
21	020310080	NUT M10, H=6	1	
22	020412070	NUT M12, H=7	1	
23	022411635	WING NUT M16	1	
25	954404230	CLAMP SA120-18	1	
26	011206020	BOLT 6X20 T	1	
27	030206150	WASHER, LOCK M6	1	
28	952404470	WASHER, FLAT M6	1	
29	020106050	NUT M6	1	
34	501402870	HANDLE STOPPER	1	
35	501402880	SPRING/HANDLE (1.4X18X44)	1	
36	959403460	BALL GRIP 32D-M10	1	
37	020310080	NUT M10, H=6	1	
38	456449980	RUBBER PACKING 9D-20D-5T	1	
39	953405260	PACKING 1/4 (CU)	1	
40	031110160	WASHER, FLAT M10	1	
43	464343690	HANDLE COVER	1	
44	0105050616	BOLT 6X15 T	6	
45	030206150	WASHER, LOCK M6	6	
46	952404470	WASHER, FLAT M6	6	
47	464457710	PACKING A, HANDLE COVER	1	
48	464457720	PACKING B, HANDLE COVER	1	
49	454010020	CLAMP TC-100	1	

# CONTROL HANDLE ASSY.

CONTROL HANDLE ASSY.

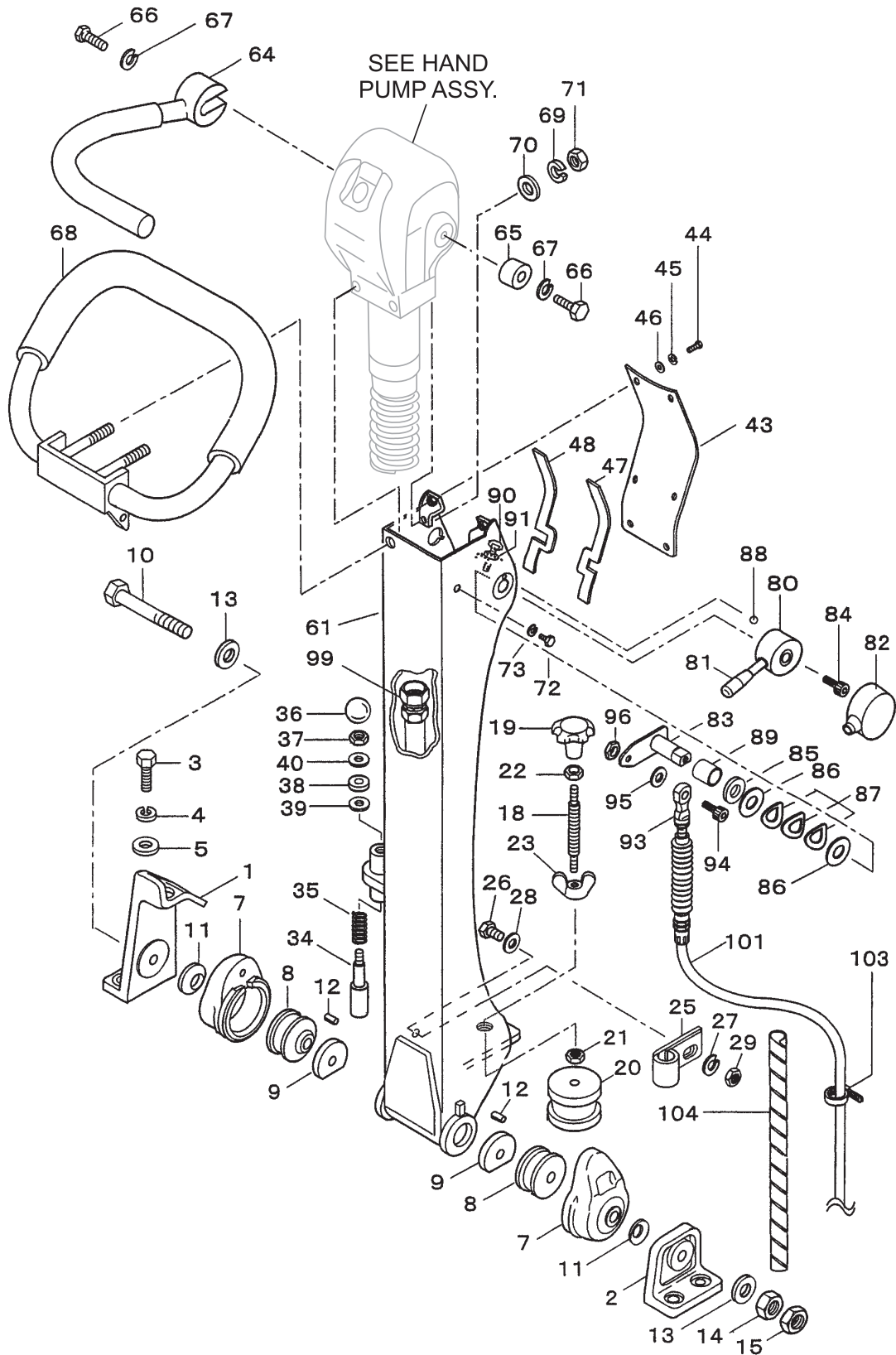

## CONTROL HANDLE ASSY.

### CONTROL HANDLE ASSY.

<u>NO.</u>	<u>PART NO.</u>	<u>PART NAME</u>	<u>QTY.</u>	<u>REMARKS</u>
61	464117890	HANDLE	1	
64	464216630	TRAVEL LEVER	1	
65	464457400	HANDLE BOSS	1	
66	012010030	BOLT 10X30 T	2	
67	030210250	WASHER, LOCK M10	2	
68	464216620	GRIP	1	
69	030210250	WASHER, LOCK M10	2	
70	031110160	WASHER, FLAT M10	2	
71	020310080	NUT M10	2	
72	011208025	BOLT 8X25 T	2	
73	030208200	WASHER, LOCK	2	
80	464457340	THROTTLE LEVER	1	
81	959403840	BAR GRIP I.D. 12 MM	1	
82	464457420	COVER, THROTTLE	1	
83	464457350	ARM, THROTTLE	1	
84	001520820	SOCKET HEAD BOLT 8X20 T	1	
85	031116260	WASHER, FLAT	1	
86	458460660	WASHER 16.4-35-0.6	2	
87	033910080	CONICAL SW 16.3 X 31.5 X 1.2	3	
88	464457440	STEEL BALL D6 (SUJ)	1	
89	464010010	DRY BUSHING/ LBF-1620	1	
90	001220625	BOLT 6X25 T	2	
91	020306050	NUT M6	2	
93	464010020	ROD END M5	1	
94	001520520	SOCKET HEAD BOLT 5X20 T	1	
95	031105080	WASHER, FLAT M5	1	
96	20305040	NUT M5	1	
99	954002270	OIL HOSE W/SPRING 1/4 X 920	1	
101	956100055	THROTTLE WIRE	1	
103	454010020	CLAMP TC-100	1	
104	959021815	SPRIAL TUBE 6D-330L	1	
104	959021810	SPRIAL TUBE KEP6/ L=500	1	

# HAND PUMP ASSY.

HAND PUMP ASSY.

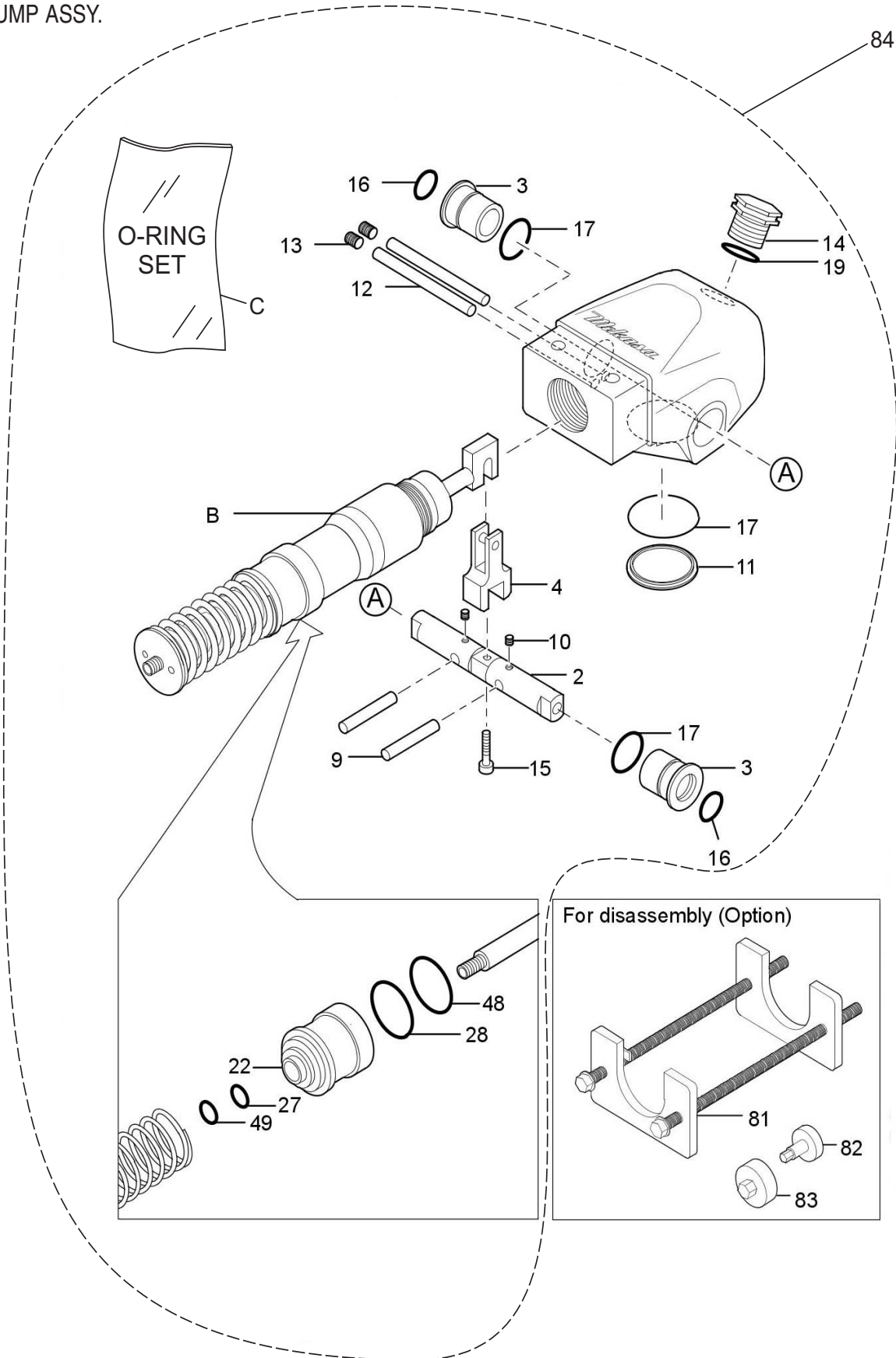

# HAND PUMP ASSY.

## HAND PUMP ASSY.

<u>NO.</u>	<u>PART NO.</u>	<u>PART NAME</u>	<u>QTY.</u>	<u>REMARKS</u>
B*	4649-10040	ACCUMULATOR	1	
C*	464910080	O-RING DUST,SEAL,SET .....	1 .....	INCLUDES ITEMS W/#
2*	464010040	CONTROL SHAFT	1	
3*	464010050	BUSH	2	
4*	464010060	CAM	1	
9*	464010070	STOPPER	2	
10*	099205005	SOCKET HEAD SCREW 5X5 T	2	
11*	464010080	PLUG	1	
12*	464010090	PIN,STOPPER	2	
13*	464010100	PLUG	2	
14*	458010080	BREATHER	1	
15*	001520620	SOCKET HEAD BOLT 6X20 T	1	
16#*	050200200	O-RING P-20	2	
17#*	050200220	O-RING P-22	2	
19#*	050200180	O-RING P-18	1	
22*	464010110	ACCUMULATOR CASE .....	1 .....	S/N N2418 AND BELOW
22*	464010111	ACCUMULATOR CASE .....	1 .....	S/N N2419 AND ABOVE
26#*	050300400	O-RING S-40	1	
27#*	050200150	O-RING P-15	1	
28#*	050100400	O-RING G-40	1	
48#*	069904010	DUST SEAL SER-40 .....	1 .....	S/N N2419 AND ABOVE
49#*	069901010	DUST SEAL SER-15 .....	1 .....	S/N N2419 AND ABOVE
81	984010030	SPRG.COMPRESSION TOOL	1	
82	984010040	DISASSEMBLING TOOL A	1	
83	984010050	DISASSEMBLING TOOL B	1	
84	464216721	HAND PUMP ASSY .....	1 .....	INCLUDES ITEMS W/*

# GX270K1SMX2 — AIR CLEANER ASSY.

AIR CLEANER ASSY.

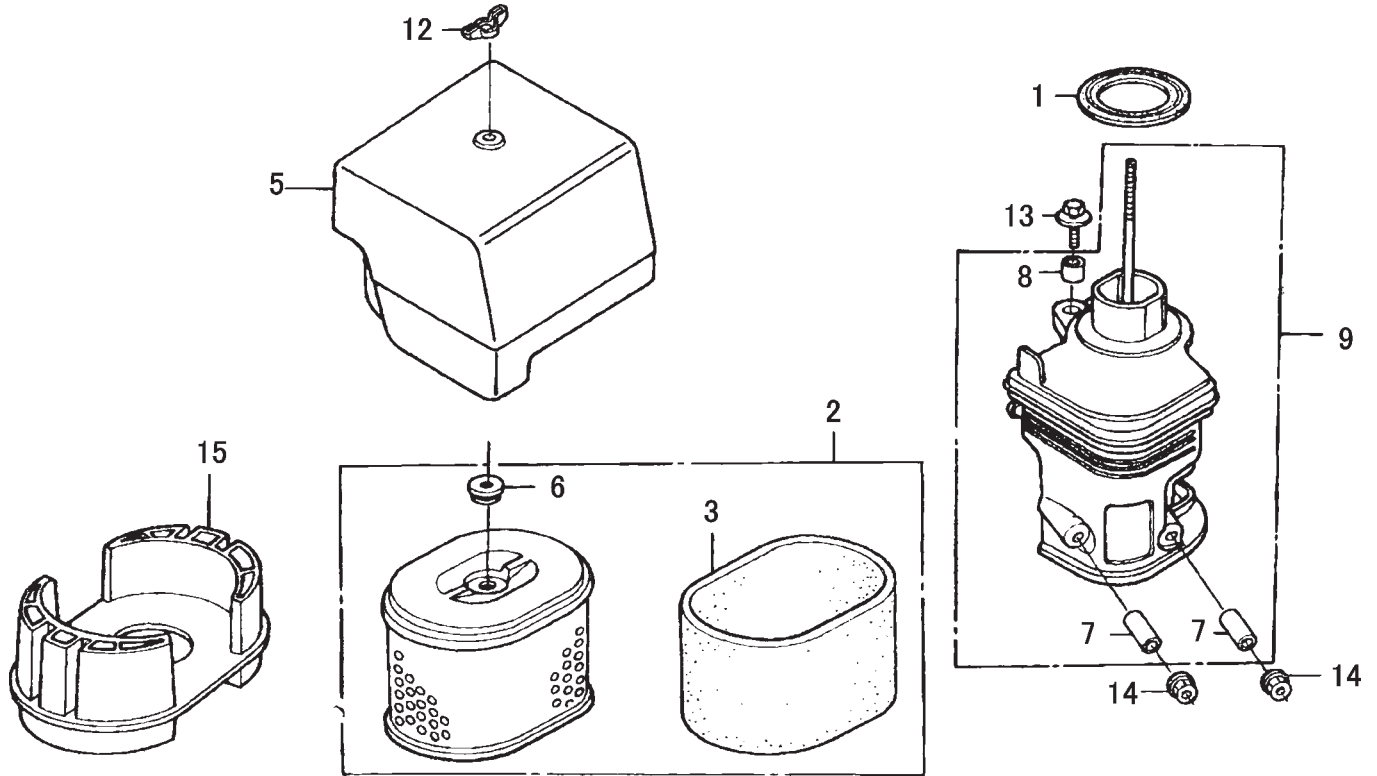

## **GX270K1SMX2 — AIR CLEANER ASSY.**

---

### AIR CLEANER ASSY.

<u>NO.</u>	<u>PART NO.</u>	<u>PART NAME</u>	<u>QTY.</u>	<u>REMARKS</u>
1	16271ZE2010	PACKING, ELBOW	1	
2	17210ZE2822	ELEMENT,AIR CLEANER(DUAL) .....	1 .....	INCLUDES ITEM W/*
3*	17218ZE2821	FILTER, OUTER	1	
5	17231ZH9820	COVER, AIR CLEANER	1	
6*	17232891000	GROMET,AIR CLEANER	1	
7+	17238ZE2310	COLLAR,AIR CLEANER	2	
8+	17239ZE1000	COLLAR(B),AIR CLEANER	1	
9	17410ZE2020	ELBOW COMP.,AIR CLEANER .....	1 .....	INCLUDES ITEM W/+
12	90325044000	NUT	1	
13	90009ZE2003	BOLT-WASHER 6X22	1	
14	9405006000	FLANGE NUT 6MM	2	
15	17235ZE2820	NOSE, SILENCER	1	

# GX270K1SMX2 — CAMSHAFT ASSY.

CAMSHAFT ASSY.

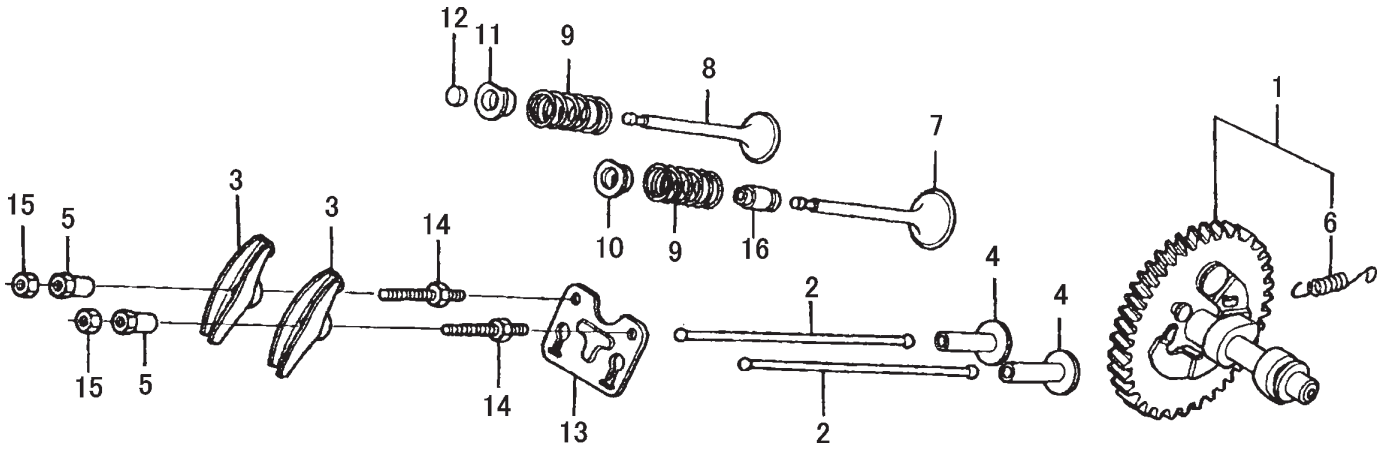

## **GX270K1SMX2 — CAMSHAFT ASSY.**

---

### CAMSHAFT ASSY.

<b><u>NO.</u></b>	<b><u>PART NO.</u></b>	<b><u>PART NAME</u></b>	<b><u>QTY.</u></b>	<b><u>REMARKS</u></b>
1	14100ZE3020	CAMSHAFT ASSY .....	1 .....	INCLUDES ITEM W/*
2	14410ZE2013	ROD,PUSH	2	
3	14431ZE2010	ARM,VALVE ROCKER	2	
4	14441ZE2000	LIFTER,VALVE	2	
5	14451ZE1013	PIBOT,ROCKER ARM	2	
6*	14568ZE1000	SPRING,WEIGHT RETURN	1	
7	14711ZE2000	VALVE, IN.	1	
8	14721ZE2000	VALVE, EX.	1	
9	14751ZE2003	SPRING,VALVE	2	
10	14771ZE2000	RETAINER,IN.VALVE SPRING	1	
11	14773ZE2000	RETAINER,EX.VALVE SPRING	1	
12	14781ZE2000	ROTATOR,VALVE	1	
13	14791ZE2010	PLATE,PUSH ROD GUIDE	1	
14	90012ZE0010	PIBOT BOLT 8MM	2	
15	90206ZE1000	NUT,PIBOT ADJUSTING	2	
16	12209ZE8003	SEAL, VALVE STEM	1	

# GX270K1SMX2 — CARBURETOR ASSY.

CARBURETOR ASSY.

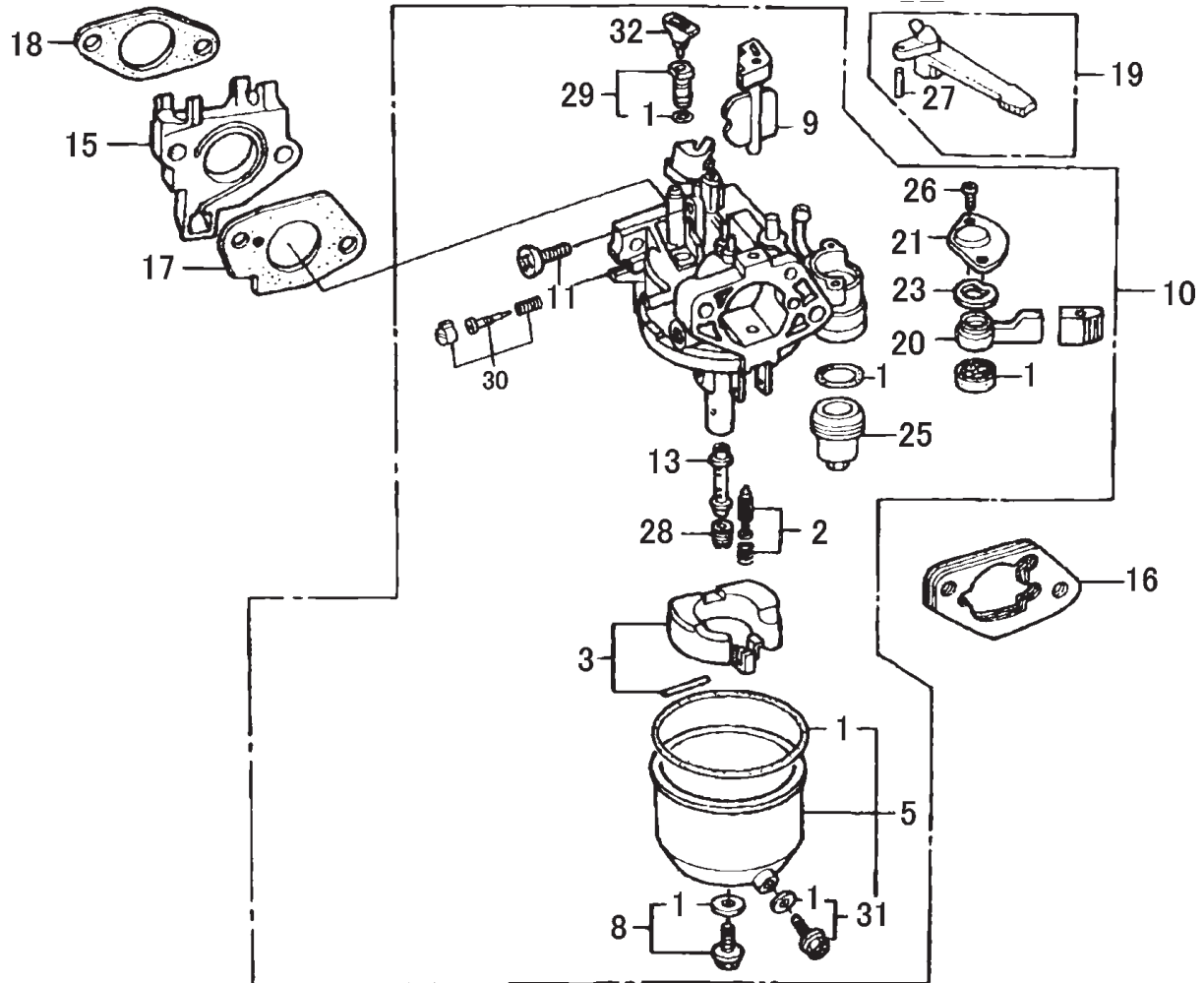

## GX270K1SMX2 — CARBURETOR ASSY.

### CARBURETOR ASSY.

<u>NO.</u>	<u>PART NO.</u>	<u>PART NAME</u>	<u>QTY.</u>	<u>REMARKS</u>
1*%	16010ZE2812	GASKET SET	1	
2*	16011ZA0931	VALVE SET,FLOAT	1	
3*	16013ZA0931	FLOAT SET	1	
5*	16015ZE8005	CHAMBER SET,FLOAT .....	1	INCLUDES ITEM W/%
8*	16028ZE0005	SCREW SET	1	
9*	16044ZE2005	CHOKE SET	1	
10	16100ZH9W21	CARBURETOR ASSY. (BE75B) .....	1	INCLUDES ITEM W/*
11*	16124ZE0005	SCREW, THROTTLE STOP	1	
13*	16166ZH9W20	NOZZLE, MAINE	1	
14*	16173001004	PACKING,CUP	1	
15	16211ZE2000	INSULATOR, CARBURETOR	1	
16	16220ZA0702	SPACER COMP.,CARBURETOR	1	
17	16221ZA0800	PACKING, CARBURETOR	1	
18	16223ZA0800	PACKING, INSULATOR	1	
19	16610ZE1000	CHOKE LEVER COMP.....	1	INCLUDES ITEM W/+
20	16953ZE1812	LEVER,COCK	1	
21*	16954ZE1812	PLATE,LEVER SETTING	1	
23*	16956ZE1811	SPRING,COCK LEVER	1	
24*	16957ZE1812	PACKING,FUEL COCK	1	
25*	16967ZE0811	CUP,FUEL STRAINER	1	
26*	93500030061H	SCREW 3X6	2	
27+	9430520122	SPRING PIN 2X12	1	
28*	99101ZH80800	JET, MAIN, #80	1	
29*	99204ZE20400	JET SET,PILOT, #40	1	
30*	16016ZH7W01	SCREW SET	1	
31*%	16024ZE1811	DRAIN SCREW SET	1	
32*	16172ZE3W10	COLLAR SET	1	

# GX270K1SMX2 — CONTROL ASSY.

CONTROL ASSY.

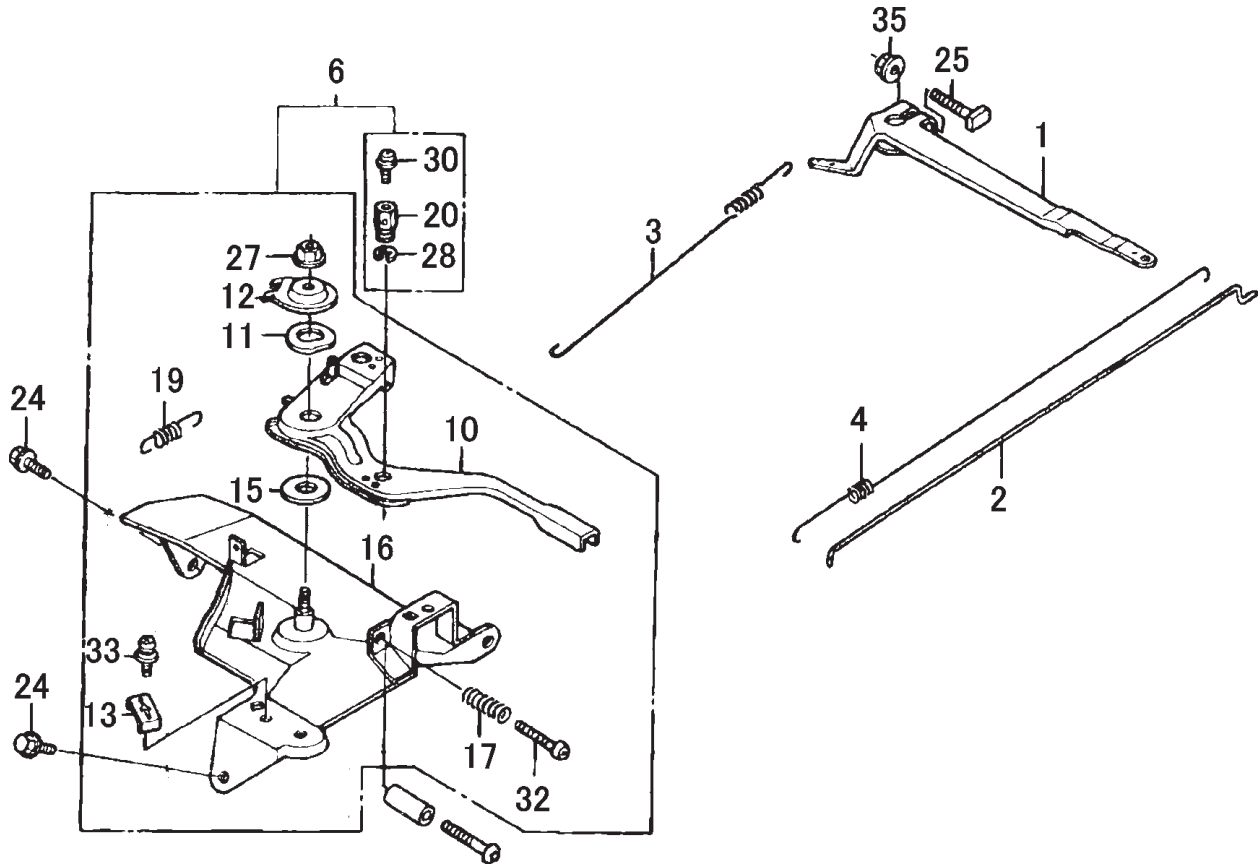

## GX270K1SMX2 — CONTROL ASSY.

---

### CONTROL ASSY.

<u>NO.</u>	<u>PART NO.</u>	<u>PART NAME</u>	<u>QTY.</u>	<u>REMARKS</u>
1	16551ZE2000	ARM, GOVERNOR	1	
2	16555ZE2000	ROD, GOVERNOR	1	
3	16561ZE2000	SPRING, GOVERNOR	1	
4	16562ZE2000	SPRING, THROTTLE RETURN	1	
6	16570ZE2W10	CONTROL ASSY.(REMOTE) .....	1	..... INCLUDES ITEM W/*
10*	16571ZE2W00	LEVER, CONTROL	1	
11*	16574ZE1000	LEVER SPRING	1	
12*	16575ZE2W00	WASHER, CONTROL LEVER	1	
13*	16576891000	HOLDER, CABLE	1	
15*	16578ZE1000	SPACER, CONTROL LEVER	1	
16*	16581ZE2W00	BASE COMP., CONTROL	1	
17*	16584883300	ADJUSTING SPRING	1	
19*	16592883310	SPRING, CABLE RETURN	1	
20*	16594883010	HOLDER, WIRE	1	
24	90013883000	FLANGE BOLT 6X12	2	
25	90015ZE5010	BOLT, GOVERNOR ARM	1	
27*	90114SA0000	LOCK NUT 6MM	1	
28*	90605230000	CIR CLIP	1	
30*	93500040060H	SCREW 4X6	1	
32*	93500050280A	SCREW, PAN 5X28	1	
33*	93500050160A	SCREW 5X16	1	
35	9405006000	FLANGE NUT 6MM	1	



## **GX270K1SMX2 — CRANKCASE COVER ASSY.**

---

### CRANKCASE COVER ASSY.

<b>NO.</b>	<b>PART NO.</b>	<b>PART NAME</b>	<b>QTY.</b>	<b>REMARKS</b>
2	11300ZH9S50	COVER ASSY., CRANKCASE .....	1 .....	INCULDES ITEM W/*
3	11381ZE2801	PACKINNG,CASE COVER	1	
4	15600735003	CAP ASSY.,OIL FILLER .....	1 .....	INCLUDES ITEM W/%
6	15600ZG4003	OIL PLUG .....	1 .....	INCLUDES ITEM W/%
8%	15625ZE1003	PACKING, OIL FILLER CAP	2	
9*	16510ZE2000	GOVERNOR ASSY.....	1 .....	INCLUDES ITEM W/+
10*+	16511ZE2000	WEIGHT, GOVERNOR	2	
11*+	16512ZE2000	HOLDER, GOVERNOR WEIGHT	1	
12*+	16513ZE2000	PIN,GOVERNOR WEIGHT	2	
13*	16531Z0A000	SLIDER, GOVERNOR	1	
15*	90602ZE1000	CLIP, GOVERNOR HOLDER	1	
16	90701HC4000	PIN,DOWEL 8X12	2	
17*	91201890003	OIL SEAL, 30X46X8	1	
18*	9410106800	PLAIN WASHER 6MM	1	
19	957010803500	FLANGE BOLT 8X35	7	
20*	961006206000	BALL BEARING 6206	1	

# GX270K1SMX2 — CRANKSHAFT ASSY.

CRANKSHAFT ASSY.

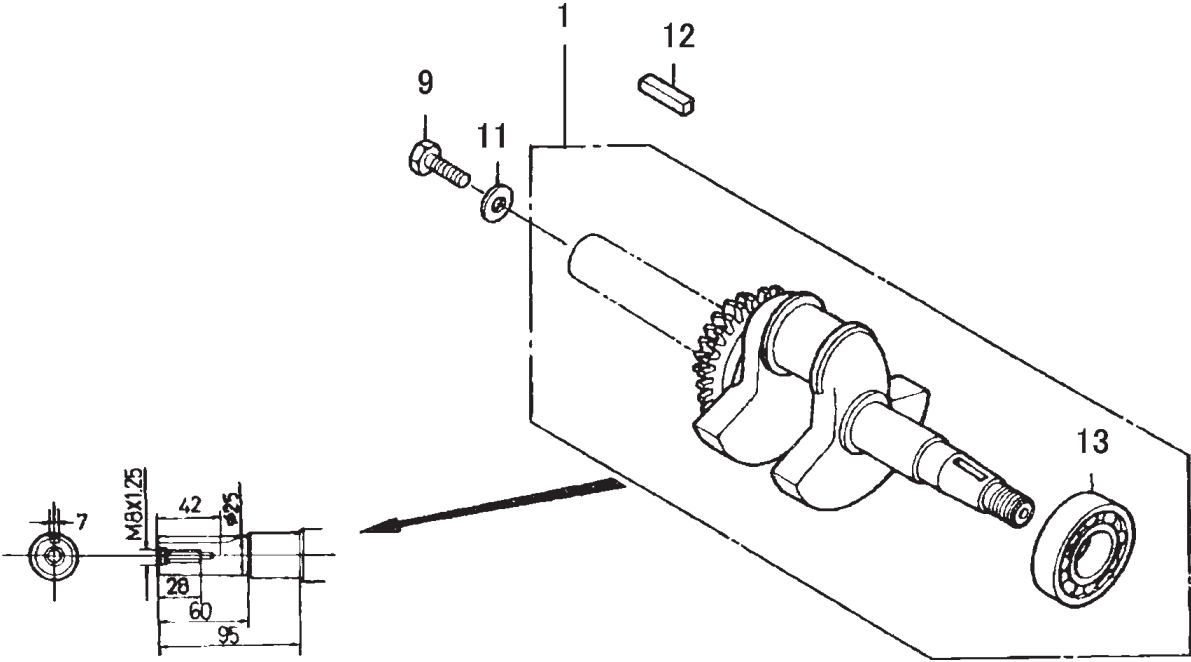

## **GX270K1SMX2 — CRANKSHAFT ASSY.**

---

### CRANKSHAFT ASSY.

<b><u>NO.</u></b>	<b><u>PART NO.</u></b>	<b><u>PART NAME</u></b>	<b><u>QTY.</u></b>	<b><u>REMARKS</u></b>
1	13310ZH9000	CRANK SHAFT COMP. ....	1 .....	INCULDES ITEM W/*
9	92101080250A	BOLT 8X25	1	
11	90534706010	WASHER, LOCK 8MM	1	
12	951400110	KEY 7X7X35	1	
13*	91001ZH9003	BEARING, BALL (6206 SH)	1	

# GX270K1SMX2 — CYLINDER BARREL ASSY.

CYLINDER BARREL ASSY.

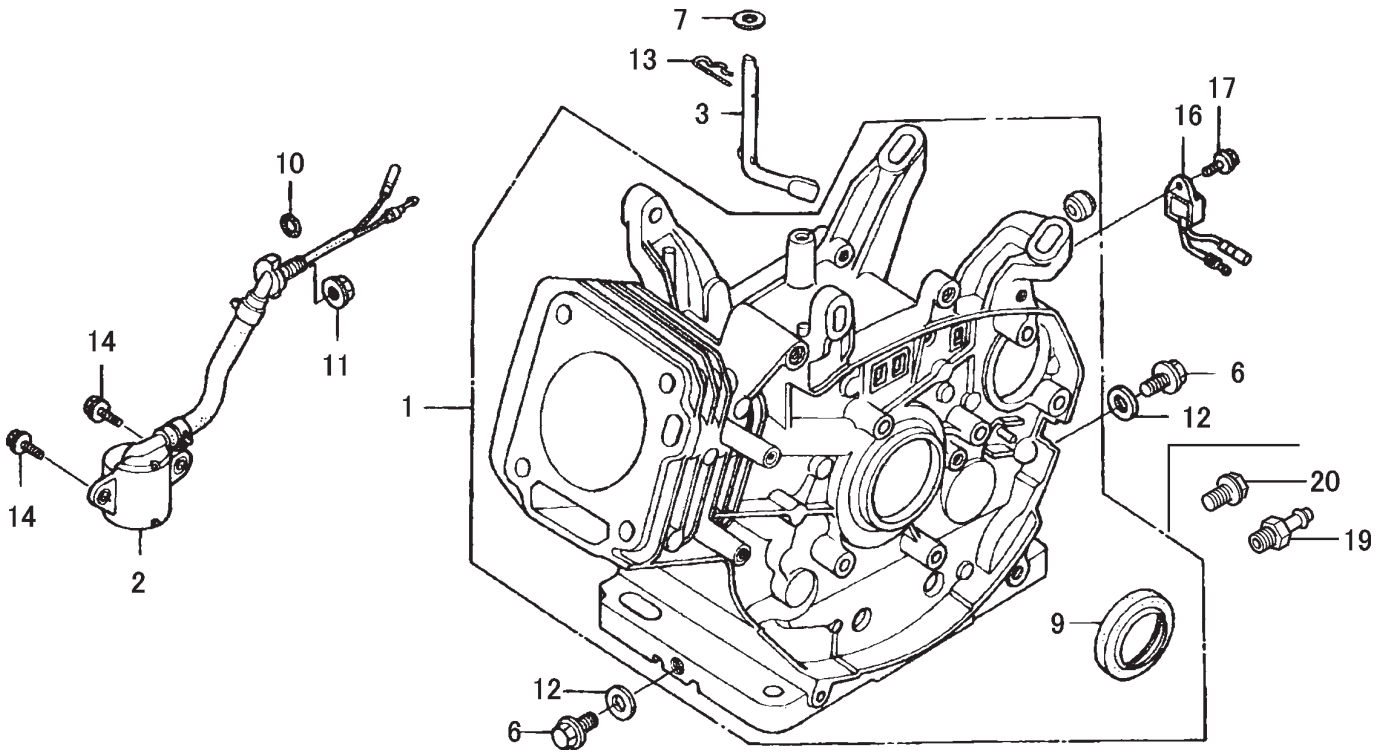

## **GX270K1SMX2 — CYLINDER BARREL ASSY.**

---

### CYLINDER BARREL ASSY.

<b><u>NO.</u></b>	<b><u>PART NO.</u></b>	<b><u>PART NAME</u></b>	<b><u>QTY.</u></b>	<b><u>REMARKS</u></b>
1	12000ZH9406	BARREL ASSY.,CYLINDER .....	1 .....	INCULDES ITEM W/*
2	15510ZE2043	SWITCH ASSY,OIL LEVEL	1	
3	16541ZE2010	SHAFT,GOVERNOR ARM	1	
6	90131883000	BOLT,DRAIN PLUG	2	
7	90446KE1000	WASHER 8.2X17X0.8	1	
9*	91201890003	OIL SEAL, 30X46X8	1	
10	91353671004	O-RING 14MM	1	
11	9405010000	FLANGE NUT M10	1	
12	9410912000	WASHER,DRAIN PLUG M12	2	
13	9425110000	PIN,LOCK 10MM	1	
14	957010601200	FLANGE BOLT 6X12	2	
16	34150ZH7003	ALERT UNIT, OIL	1	
17	90013883000	FLANGE BOLT 6X12	1	
19	90131ZE3790	DRAIN JOINT	1	
20	9280012000	BOLT, DRAIN PLUG 12MM	1	

# GX270K1SMX2 — CYLINDER HEAD ASSY.

CYLINDER HEAD ASSY.

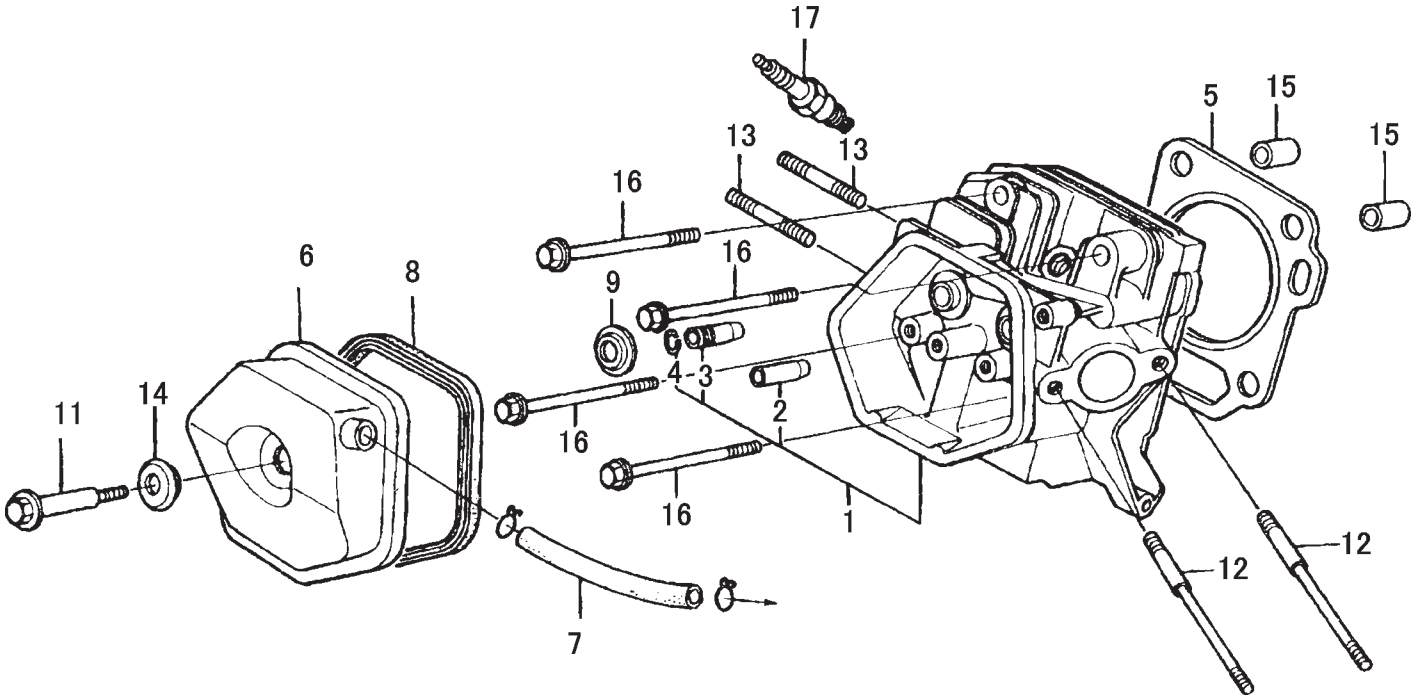

## **GX270K1SMX2 — CYLINDER HEAD ASSY.**

---

### CYLINDER HEAD ASSY.

<u>NO.</u>	<u>PART NO.</u>	<u>PART NAME</u>	<u>QTY.</u>	<u>REMARKS</u>
1	12200ZH9000	HEAD COMP.,CYLINDER .....	1 .....	INCULDES ITEM W/*
2*	12204ZE2306	GUIDE,IN.VALVE(OVERSIZE)	1	
3*	12205ZE2305	GUIDE,EX.VALVE(OVERSIZE)	1	
4*	12216ZE2300	CLIP,VALVE GUIDE	1	
5	12251ZH9000	GASKET, CYLINDER HEAD	1	
6	12310ZE2020	COVER COMP.,HEAD	1	
7	950051110030	TUBE,11X100	1	
8	12391ZE2020	PACKING,HEAD COVER	1	
9	14775ZE2010	SEAT,VALVE SPRING	1	
11	90014ZE2000	BOLT,HEAD COVER	1	
12	90042ZE2000	BOLT,STUD 8X123	2	
13	92900080320E	BOLT,STUD 8X32	2	
14	90441ZE2010	WASHER COMP.,HEAD COVER	1	
15	9430112200	PIN,DOWEL 12X20	2	
16	957251008000	BOLT,FLANGE 10X80	4	
17	9807955846	PLUG, SPARK (BPR5ES)	1	

# GX270K1SMX2 — FAN COVER ASSY.

FAN COVER ASSY.

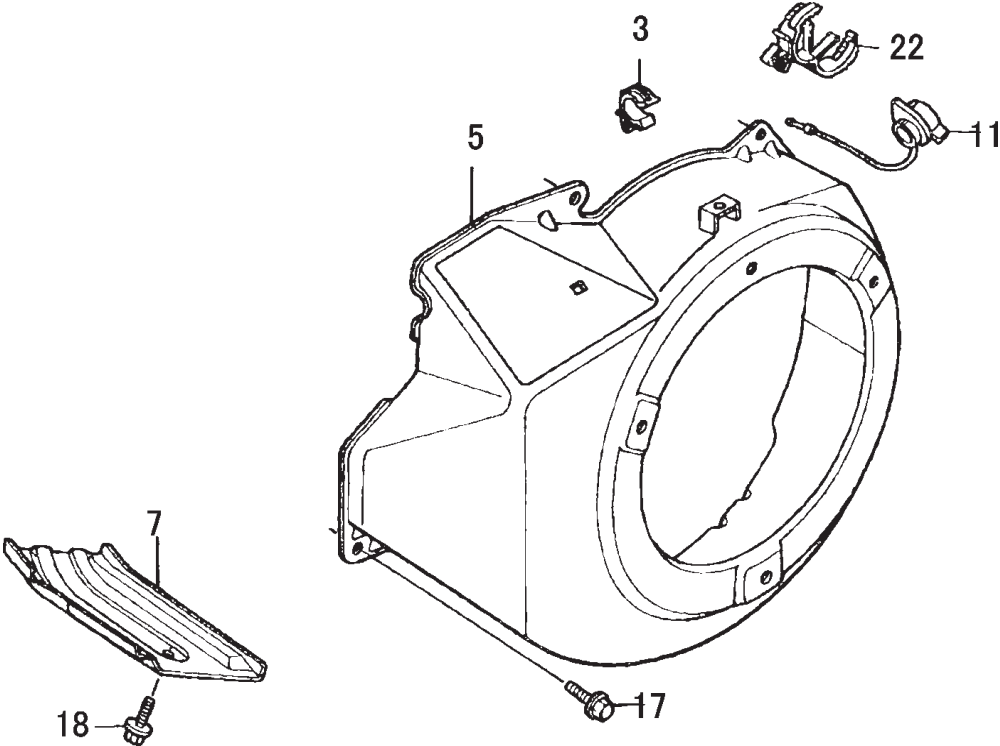

## **GX270K1SMX2 — FAN COVER ASSY.**

---

FAN COVER ASSY.

<u>NO.</u>	<u>PART NO.</u>	<u>PART NAME</u>	<u>QTY.</u>	<u>REMARKS</u>
3	16731ZE2003	CLIP,TUBE	1	
5	19610ZE2010ZC	COVER COMP.,FAN /BLACK	1	
7	19631ZE2D00	SHROUD	1	
11	36100ZH7003	STOP SWITCH ASSY.	1	
17	90013883000	FLANGE BOLT 6X12	5	
18	90013883000	FLANGE BOLT 6X12	1	
22	90684ZA0601	CLIP, HARNESS	1	

# GX270K1SMX2 — FLYWHEEL ASSY.

FLYWHEEL ASSY.

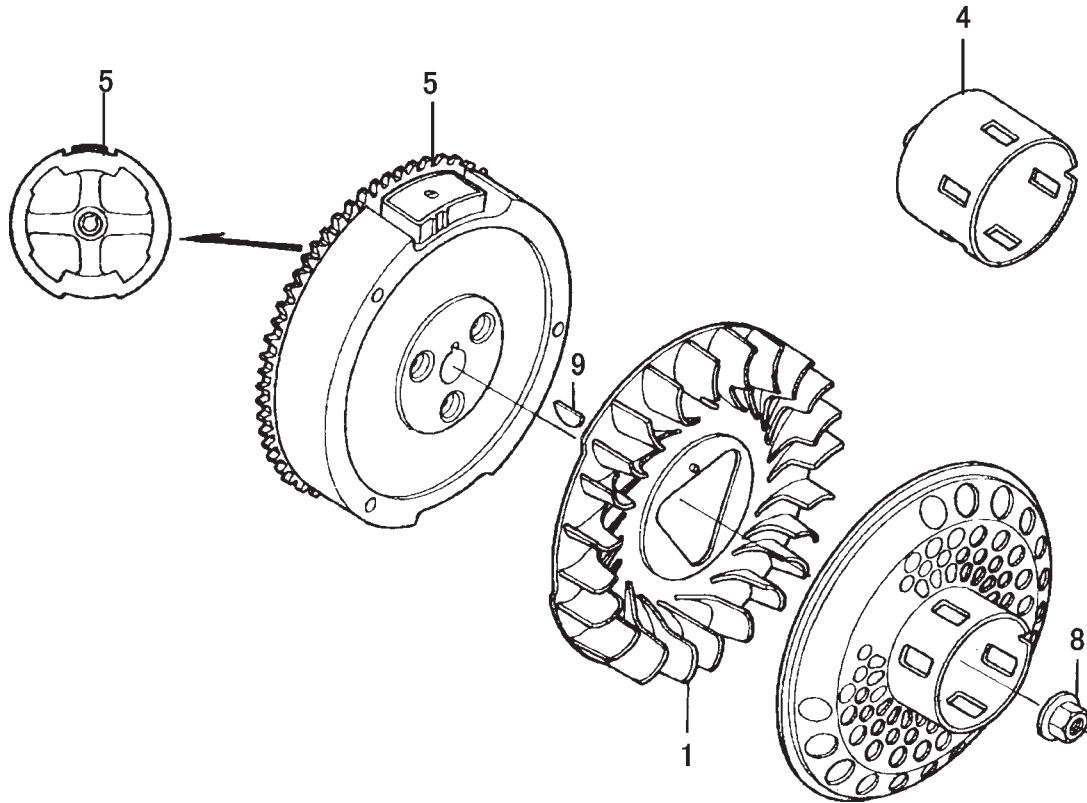

## **GX270K1SMX2 — FLYWHEEL ASSY.**

---

FLYWHEEL ASSY.

<u>NO.</u>	<u>PART NO.</u>	<u>PART NAME</u>	<u>QTY.</u>	<u>REMARKS</u>
1	19511ZE2000	FAN, COOLING	1	
4	28451ZE2W01	PULLEY, STARTER	1	
5	31100ZE2010	FLYWHEEL COMP.	1	
8	90201ZE3V00	NUT,SPECIAL 16MM	1	
9	90741ZE2000	KEY,SPECIAL WOODRUFF25X18	1	

# GX270K1SMX2 — FUEL TANK ASSY.

FUEL TANK ASSY.

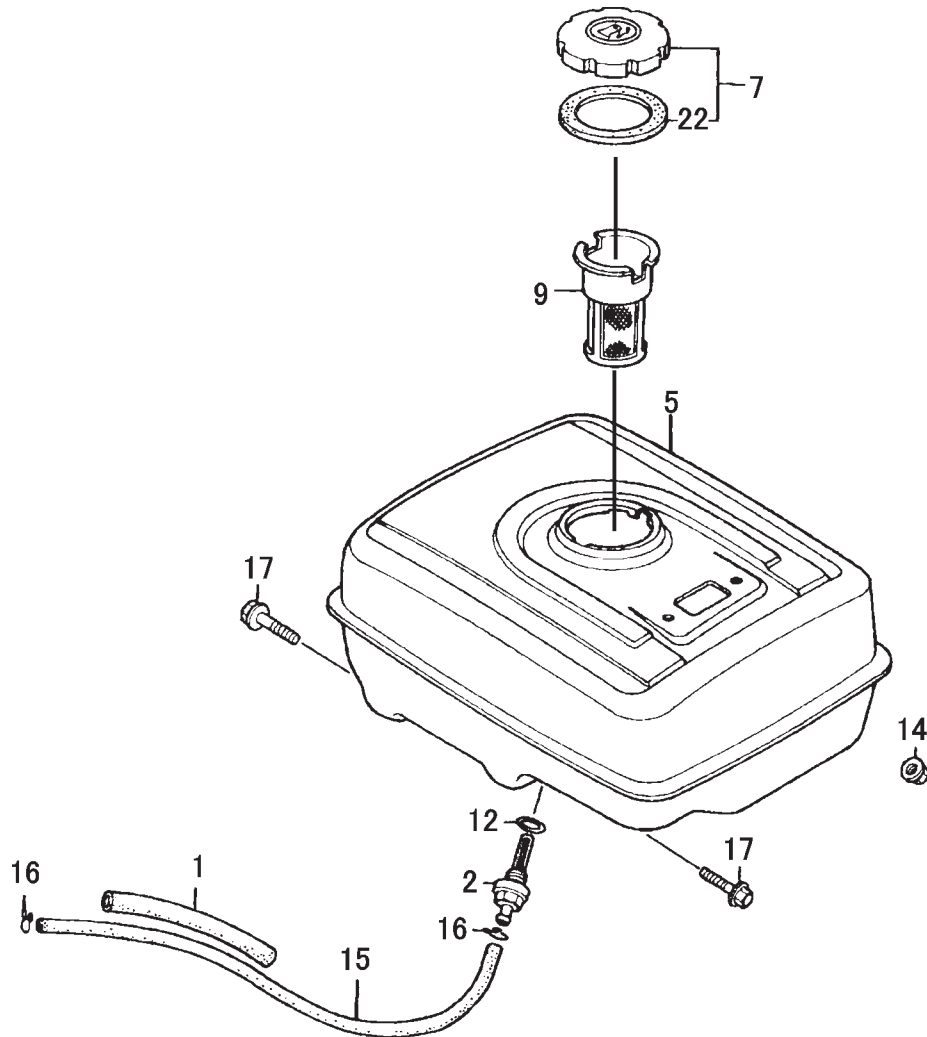

## GX270K1SMX2 — FUEL TANK ASSY.

---

### FUEL TANK ASSY.

<u>NO.</u>	<u>PART NO.</u>	<u>PART NAME</u>	<u>QTY.</u>	<u>REMARKS</u>
1	16854ZH8000	RUBBER,SUPPORT(107MM)	1	
2	16955ZE1000	JOINT,FUEL TANK	1	
5	17510ZE2020ZD	TANK COMP., FUEL NH1	1	
7	17620Z0T814	CAP COMP., FUEL FILLER .....	1 .....	INCLUDES ITEM W/*
9	17672ZE2W01	FUEL FILTER	1	
12	91353671004	O-RING 14MM	1	
14	9405008000	FLANGE NUT M8	2	
15	950014522240	TUBE, FUEEL 4.5X222	1	
16	9500202080	CLIP, TUBE	2	
17	957010802500	FLANGE BOLT 8X25	2	
22*	17631Z0T812	PAKING, FUEL FILLER CAP	1	

# GX270K1SMX2 — IGNITION COIL ASSY.

IGNITION COIL ASSY.

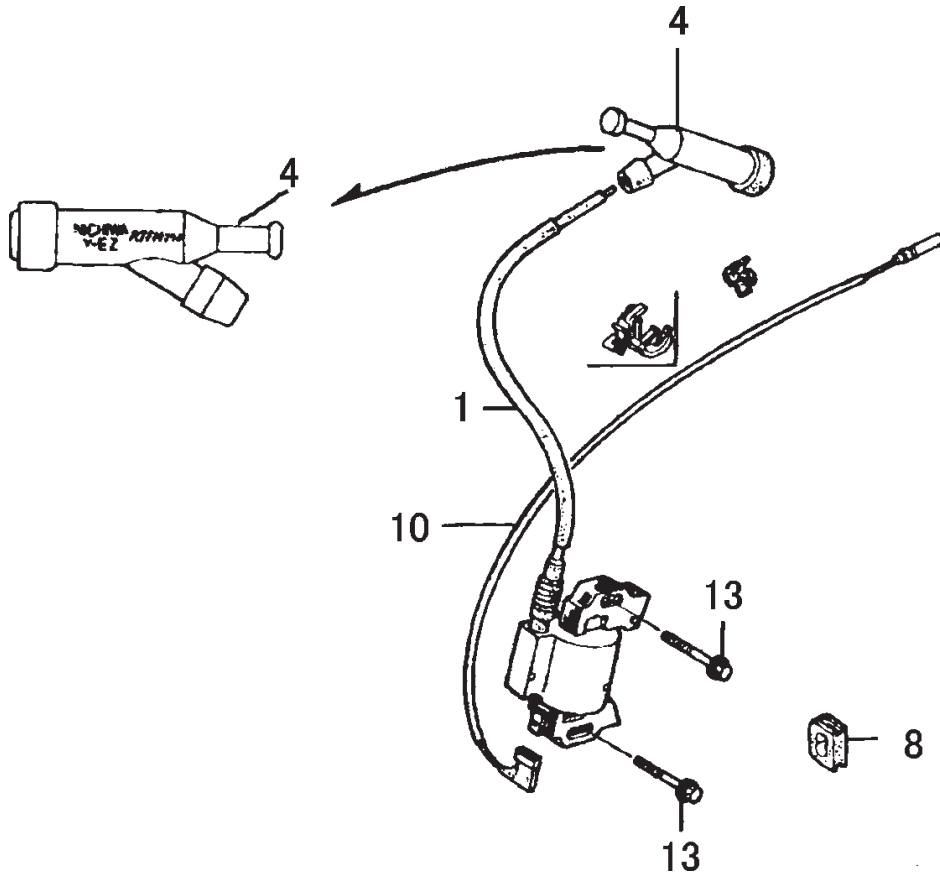

## **GX270K1SMX2 — IGNITION COIL ASSY.**

---

IGNITION COIL ASSY.

<u>NO.</u>	<u>PART NO.</u>	<u>PART NAME</u>	<u>QTY.</u>	<u>REMARKS</u>
1	30500-ZF6-W02	COIL AY,IGNITION/GX390	1	
4	30700-ZE1-013	CAP ASSY.	1	
8	31512-ZE2-000	GROMMET,CORD	1	
10	36101-ZE1-010	CORD,STOP SWITCH 370MM	1	
13	90015-883-000	FLANGE BOLT 6X28	1	

# GX270K1SMX2 — MUFFLER ASSY.

MUFFLER ASSY.

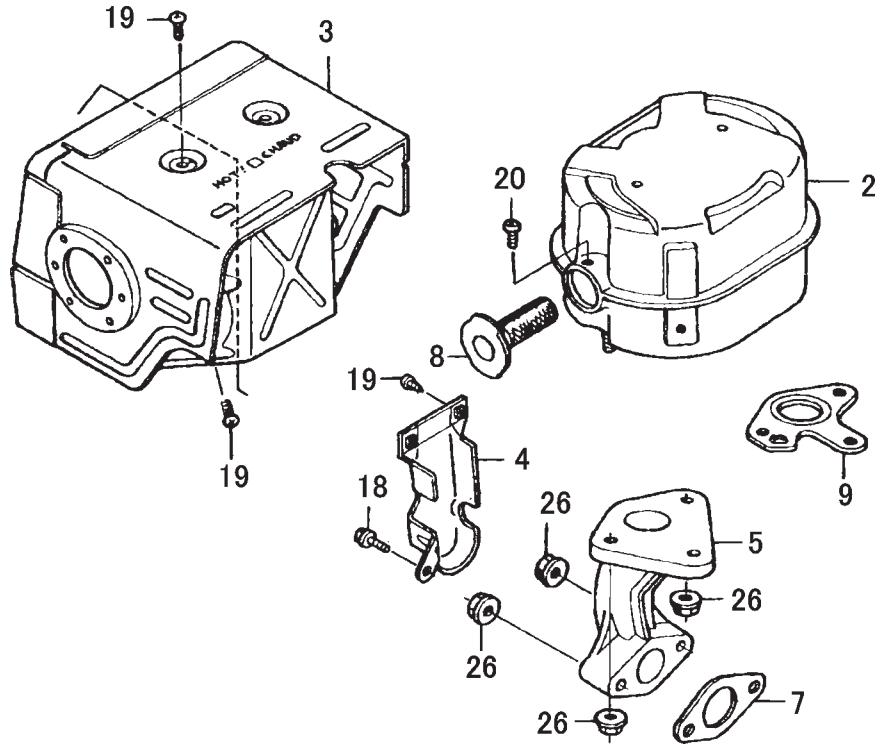

## GX270K1SMX2 — MUFFLER ASSY.

---

### MUFFLER ASSY.

<u>NO.</u>	<u>PART NO.</u>	<u>PART NAME</u>	<u>QTY.</u>	<u>REMARKS</u>
2	18310ZE2W00	MUFFLER COMP.	1	
3	18320ZE2W01	PROTECTOR COMP.,MUFFLER	1	
4	18323ZE2W00	PROTECTOR, EXHAUST PIPE	1	
5	18330ZE2W00	PIPE,EXHAUST	1	
7	18333ZE3800	GASKET	1	
8	18355ZE2010	ARRESTER, SPARK	1	
9	18381ZE2W10	GASKET,MUFFLER(ARRESTER)	1	
18	90013883000	FLANGE BOLT 6X12	1	
19	90050ZE1000	TAPPING SCREW 5X8	6	
26	9405008000	FLANGE NUT M8	3	
29	90050ZE1000	TAPPING SCREW 5X8	1	

# GX270K1SMX2 — PISTON ASSY.

PISTON ASSY.

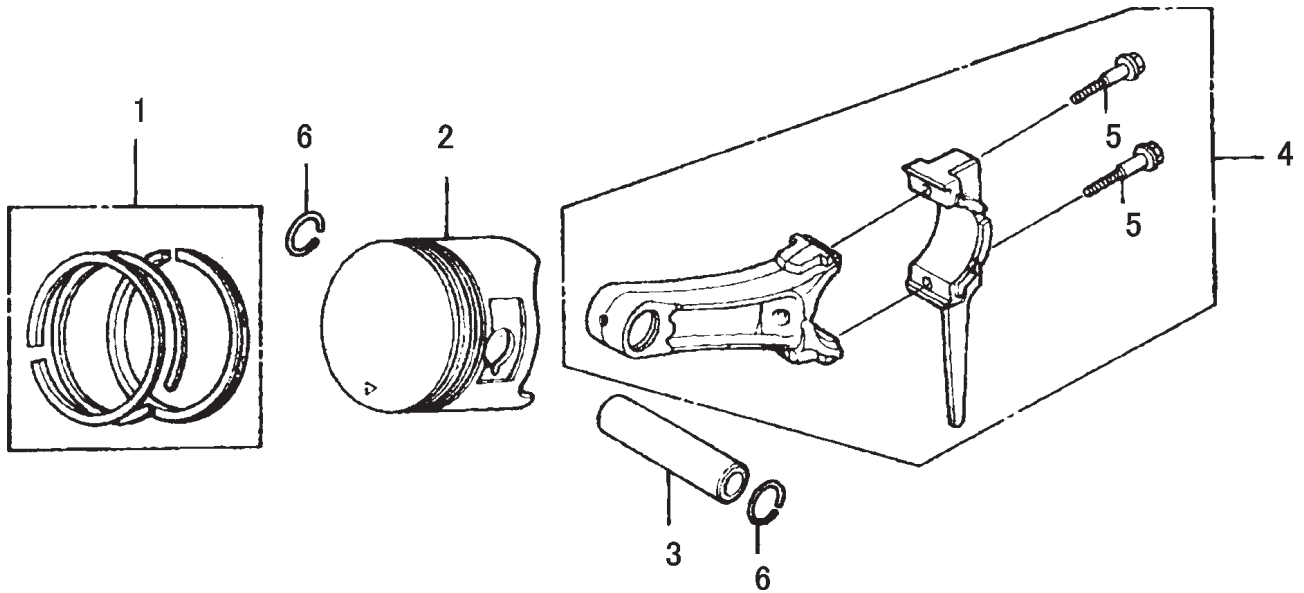

## GX270K1SMX2 — PISTON ASSY.

---

PISTON ASSY.

<u>NO.</u>	<u>PART NO.</u>	<u>PART NAME</u>	<u>QTY.</u>	<u>REMARKS</u>
1	13010ZE8601	RING SET, PISTON (STD)	1	
2	13101ZH9000	PISTON (STD)	1	
3	13111ZE2000	PIN ,PISTON	1	
4	13200E2010	ROD ASSY., CONNECTING (STD) .....	1 .....	INCLUDES ITEM W/*
5*	90001E8000	BOLT, CONNECTING ROD	2	
6	90551E1000	CLIP, PISTON PIN 18MM	2	

# GX270K1SMX2 — RECOIL STARTER ASSY.

RECOIL STARTER ASSY.

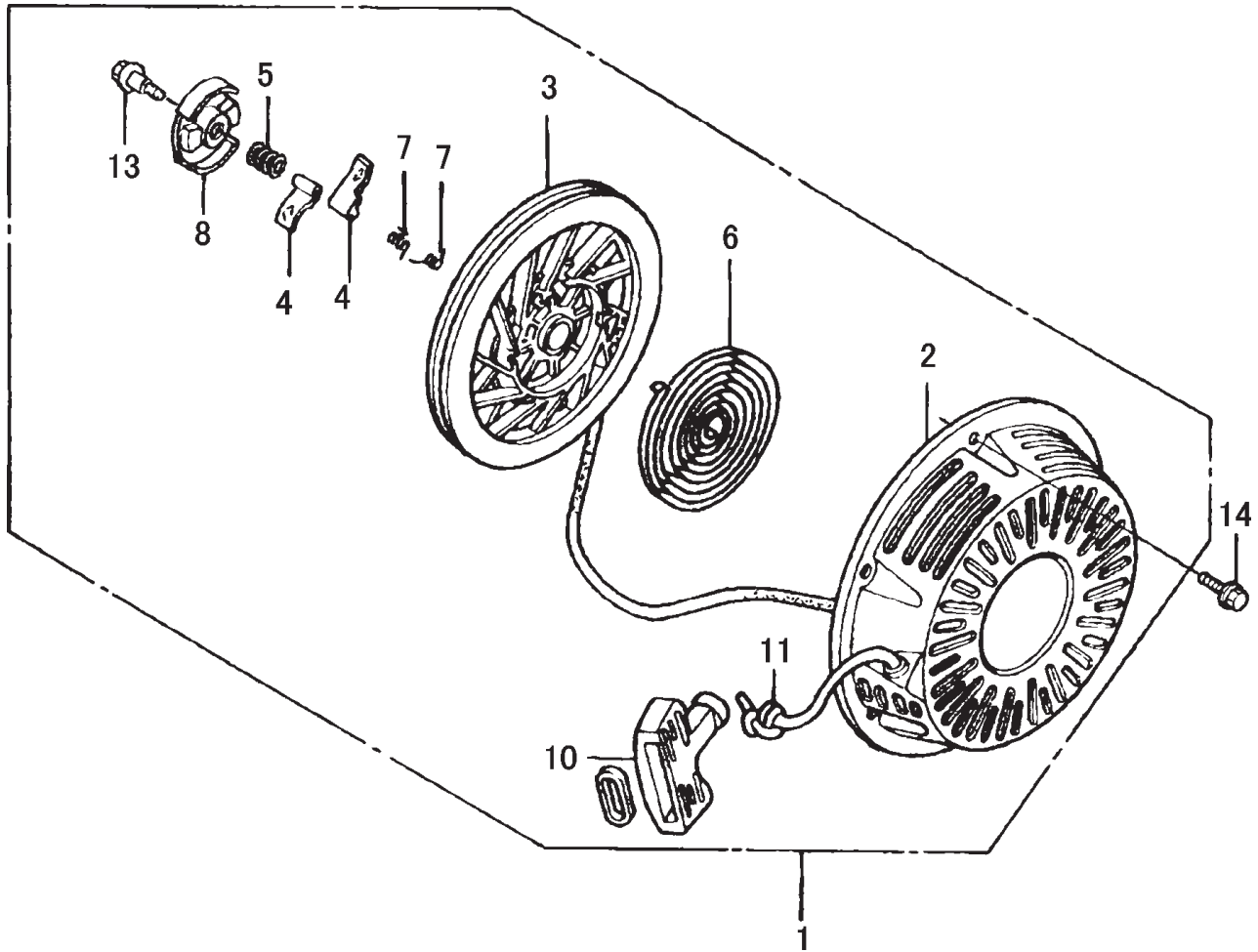

## **GX270K1SMX2 — RECOIL STARTER ASSY.**

---

### RECOIL STARTER ASSY.

<u>NO.</u>	<u>PART NO.</u>	<u>PART NAME</u>	<u>QTY.</u>	<u>REMARKS</u>
1	28400ZE2W01ZB	RECOIL STARTER AY/GX240,B .....	1 .....	INCLUDES ITEM W/*
2*	28410ZE2W01ZB	CASE COMP.,RECOIL STARTER	1	
3*	28421ZE2W01	PULLEY,RECOIL STARTER	1	
4*	28422ZE2W01	RATCHET,STARTER	2	
5*	28441ZE2W01	SPRING, FRICTION	1	
6*	28442ZE2W01	SPRING,STARTER RETURN	1	
7*	28443ZE2W01	SPRING,RATCHET	2	
8*	28444ZE2W01	RETAINER,SPRING	1	
10*	28461ZE2W02	GRIP,STARTER	1	
11*	28462ZE2W11	ROPE, RECOIL STARTER	1	
13*	90004ZE2W01	SCREW,CENTER	1	
14	90008ZE2003	BOLT,FLANGE 6X10	3	

# GX270K1SMX2 — LABELS ASSY.

LABELS ASSY.

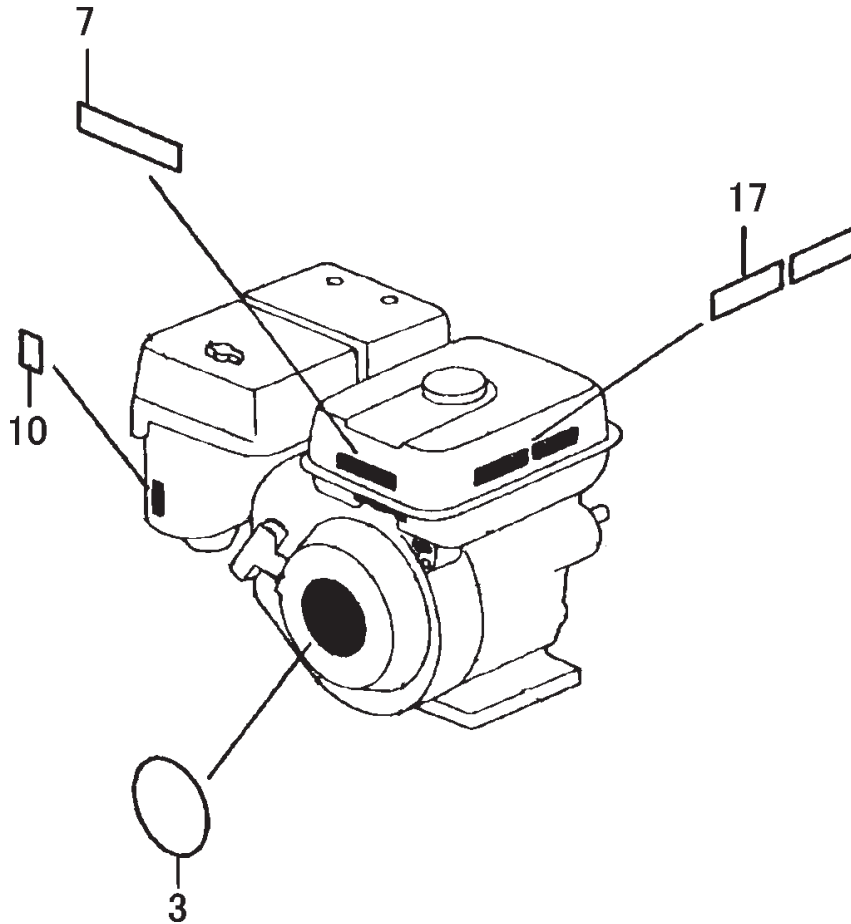

## GX270K1SMX2 — LABELS ASSY.

---

LABELS ASSY.

<u>NO.</u>	<u>PART NO.</u>	<u>PART NAME</u>	<u>QTY.</u>	<u>REMARKS</u>
3	87521ZH9030	EMBLEM	1	
7	87522ZH9010	RABEL /GX120K1	1	
10	87528ZE2810	MARK,CHOKE(ORANGE)	1	
17	87532ZH8810	LABEL	1	

# TERMS AND CONDITION OF SALE — PARTS

## PAYMENT TERMS

Terms of payment for parts are net 30 days.

## FREIGHT POLICY

All parts orders will be shipped collect or prepaid with the charges added to the invoice. All shipments are F.O.B. point of origin. Multiquip's responsibility ceases when a signed manifest has been obtained from the carrier, and any claim for shortage or damage must be settled between the consignee and the carrier.

## MINIMUM ORDER

The minimum charge for orders from Multiquip is \$15.00 net. Customers will be asked for instructions regarding handling of orders not meeting this requirement.

## RETURNED GOODS POLICY

Return shipments will be accepted and credit will be allowed, subject to the following provisions:

1. A Returned Material Authorization must be approved by Multiquip prior to shipment.
2. To obtain a Return Material Authorization, a list must be provided to Multiquip Parts Sales that defines item numbers, quantities, and descriptions of the items to be returned.
  - a. The parts numbers and descriptions must match the current parts price list.
  - b. The list must be typed or computer generated.
  - c. The list must state the reason(s) for the return.
  - d. The list must reference the sales order(s) or invoice(s) under which the items were originally purchased.
  - e. The list must include the name and phone number of the person requesting the RMA.
3. A copy of the Return Material Authorization must accompany the return shipment.
4. Freight is at the sender's expense. All parts must be returned freight prepaid to Multiquip's designated receiving point.

5. Parts must be in new and resalable condition, in the original Multiquip package (if any), and with Multiquip part numbers clearly marked.
6. The following items are not returnable:
  - a. Obsolete parts. (If an item is in the price book and shows as being replaced by another item, it is obsolete.)
  - b. Any parts with a limited shelf life (such as gaskets, seals, "O" rings, and other rubber parts) that were purchased more than six months prior to the return date.
  - c. Any line item with an extended dealer net price of less than \$5.00.
  - d. Special order items.
  - e. Electrical components.
  - f. Paint, chemicals, and lubricants.
  - g. Decals and paper products.
  - h. Items purchased in kits.
7. The sender will be notified of any material received that is not acceptable.
8. Such material will be held for five working days from notification, pending instructions. If a reply is not received within five days, the material will be returned to the sender at his expense.
9. Credit on returned parts will be issued at dealer net price at time of the original purchase, less a 15% restocking charge.
10. In cases where an item is accepted, for which the original purchase document can not be determined, the price will be based on the list price that was effective twelve months prior to the RMA date.
11. Credit issued will be applied to future purchases only.

## PRICING AND REBATES

Prices are subject to change without prior notice. Price changes are effective on a specific date and all orders received on or after that date will be billed at the revised price. Rebates for price declines and added charges for price increases will not be made for stock on hand at the time of any price change.

Multiquip reserves the right to quote and sell direct to Government agencies, and to Original Equipment Manufacturer accounts who use our products as integral parts of their own products.

## SPECIAL EXPEDITING SERVICE

A \$35.00 surcharge will be added to the invoice for special handling including bus shipments, insured parcel post or in cases where Multiquip must personally deliver the parts to the carrier.

## LIMITATIONS OF SELLER'S LIABILITY

Multiquip shall not be liable hereunder for damages in excess of the purchase price of the item with respect to which damages are claimed, and in no event shall Multiquip be liable for loss of profit or good will or for any other special, consequential or incidental damages.

## LIMITATION OF WARRANTIES

No warranties, express or implied, are made in connection with the sale of parts or trade accessories nor as to any engine not manufactured by Multiquip. Such warranties made in connection with the sale of new, complete units are made exclusively by a statement of warranty packaged with such units, and Multiquip neither assumes nor authorizes any person to assume for it any other obligation or liability whatever in connection with the sale of its products. Apart from such written statement of warranty, there are no warranties, express, implied or statutory, which extend beyond the description of the products on the face hereof.

Effective: February 22, 2006



# OPERATION AND PARTS MANUAL

## HERE'S HOW TO GET HELP

PLEASE HAVE THE MODEL AND SERIAL  
NUMBER ON-HAND WHEN CALLING

### UNITED STATES

#### ***Multiquip Corporate Office***

18910 Wilmington Ave.  
Carson, CA 90746  
Contact: mq@multiquip.com

Tel. (800) 421-1244  
Fax (800) 537-3927

#### ***Service Department***

800-421-1244  
310-537-3700

Fax: 310-537-4259

#### ***Technical Assistance***

800-478-1244

Fax: 310-943-2238

#### ***MQ Parts Department***

800-427-1244  
310-537-3700

Fax: 800-672-7877  
Fax: 310-637-3284

#### ***Warranty Department***

800-421-1244  
310-537-3700

Fax: 310-943-2249

---

### MEXICO

#### ***MQ Cipsa***

Carr. Fed. Mexico-Puebla KM 126.5  
Momoxpan, Cholula, Puebla 72760 Mexico  
Contact: pmastretta@cipsa.com.mx

Tel: (52) 222-225-9900  
Fax: (52) 222-285-0420

### CANADA

#### ***Multiquip***

4110 Industriel Boul.  
Laval, Quebec, Canada H7L 6V3  
Contact: jmartin@multiquip.com

Tel: (450) 625-2244  
Tel: (877) 963-4411  
Fax: (450) 625-8664

---

### UNITED KINGDOM

#### ***Multiquip (UK) Limited Head Office***

Unit 2, Northpoint Industrial Estate,  
Globe Lane,  
Dukinfield, Cheshire SK16 4UJ  
Contact: sales@multiquip.co.uk

Tel: 0161 339 2223  
Fax: 0161 339 3226

© COPYRIGHT 2011, MULTIQUIP INC.

Multiquip Inc, the MQ logo and the Mikasa logo are registered trademarks of Multiquip Inc. and may not be used, reproduced, or altered without written permission. All other trademarks are the property of their respective owners and used with permission.

This manual MUST accompany the equipment at all times. This manual is considered a permanent part of the equipment and should remain with the unit if resold.

The information and specifications included in this publication were in effect at the time of approval for printing. Illustrations, descriptions, references and technical data contained in this manual are for guidance only and may not be considered as binding. Multiquip Inc. reserves the right to discontinue or change specifications, design or the information published in this publication at any time without notice and without incurring any obligations.

Your Local Dealer is:

