

OPERATION AND PARTS MANUAL



Tamping Rammer

Mikasa Model

MT-60H/H2

(GASOLINE ENGINE)

Revision #12 (05/29/07)

**THIS MANUAL MUST ACCOMPANY
THE EQUIPMENT AT ALL TIMES.**



WARNING 

CALIFORNIA — Proposition 65 Warning

Engine exhaust and some of its constituents are known to the State of California to cause cancer, birth defects and other reproductive harm.

**MQ MIKASA MT-60H/H2
— Tamping Rammer**

Proposition 65 Warning 2
 Table of Contents 4
 Parts Ordering Procedures 5
 Safety Message Alert Symbols 6-7
 Rules For safe Operation 8-9
 Operation and Safety Decals 10
 General Information 11
 Specification 12
 Controls and Components 13
 Operation 14-16
 Maintenance 17
 Troubleshooting Guide 18-19
 Explanation Of Codes In Remarks Column 20
 Suggested Spare Parts 21
 Name Plate And Decals Assembly 22-23
 Crankcase and Engine MT-60 H Assembly 24-25
 Crankcase and Engine MT-60H2 Assembly 26-27
 Guide Cylinder and Foot Assembly 28-29
 Tank and Handle Assembly 30-31
 Optional Parts 32-33

ROBIN EC-08GH ENGINE

Crankshaft and Piston Assembly 34-35
 Crankcase and Cylinder Head Assembly 36-37
 Govenor Assembly 38-39
 Muffler Assembly 40-41
 Carb. and Air Cleaner MT-60H Assembly 42-43
 Carb. and Airl Cleaner MT-60H2 Assembly 44-45
 Recoil Starter and Blower Assembly 46-47
 Magento Assembly 48-49

 Terms and Condition of Sale - Parts 50

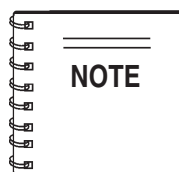

*Specification and part number
are subject to change without
notice.*

www.multiquip.com

**Ordering parts has never been easier!
Choose from three easy options:**



Order via Internet (Dealers Only):

Order parts on-line using Multiquip's SmartEquip website!

- View Parts Diagrams
- Order Parts
- Print Specification Information



If you have an MQ Account, to obtain a Username and Password, E-mail us at: parts@multiquip.com.

To obtain an MQ Account, contact your District Sales Manager for more information.

Goto www.multiquip.com and click on **Order Parts** to log in and save!

Use the **internet** and qualify for a **5% Discount** on *Standard orders* for all orders which include complete part numbers.*

Note: Discounts Are Subject To Change



Order via Fax (Dealers Only):

All customers are welcome to order parts via Fax.

Domestic (US) Customers dial:
1-800-6-PARTS-7 (800-672-7877)

Fax your order in and qualify for a **2% Discount** on *Standard orders* for all orders which include complete part numbers.*

Note: Discounts Are Subject To Change



Order via Phone: Domestic (US) Dealers Call:
1-800-427-1244

Non-Dealer Customers:

Contact your local Multiquip Dealer for parts or call 800-427-1244 for help in locating a dealer near you.



International Customers should contact their local Multiquip Representatives for Parts Ordering information.

When ordering parts, please supply:

- | | |
|---|--|
| <input type="checkbox"/> Dealer Account Number | <input type="checkbox"/> Specify Preferred Method of Shipment: |
| <input type="checkbox"/> Dealer Name and Address | <input checked="" type="checkbox"/> UPS/Fed Ex <input checked="" type="checkbox"/> DHL |
| <input type="checkbox"/> Shipping Address (if different than billing address) | <input type="checkbox"/> Priority One <input checked="" type="checkbox"/> Truck |
| <input type="checkbox"/> Return Fax Number | <input type="checkbox"/> Ground |
| <input type="checkbox"/> Applicable Model Number | <input type="checkbox"/> Next Day |
| <input type="checkbox"/> Quantity, Part Number and Description of Each Part | <input type="checkbox"/> Second/Third Day |

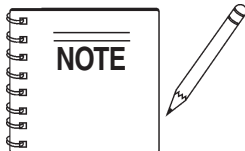

All orders are treated as *Standard Orders* and will ship the same day if received prior to 3PM PST.

WE ACCEPT ALL MAJOR CREDIT CARDS!



MT-60H/H2 — SAFETY MESSAGE ALERT SYMBOLS

FOR YOUR SAFETY AND THE SAFETY OF OTHERS!

Safety precautions should be followed at all times when operating this equipment. Failure to read and understand the Safety Messages and Operating Instructions could result in injury to yourself and others.

NOTE

This Owner's Manual has been developed to provide complete instructions for the safe and efficient operation of the MQ Mikasa Model MT-60H-H2 Tamping Rammer. Refer to the engine manufacturer's instructions for data relative to its safe operation.

Before using this tamping rammer, ensure that the operating individual has read and understands all instructions in this manual.

SAFETY MESSAGE ALERT SYMBOLS

The three (3) Safety Messages shown below will inform you about potential hazards that could injure you or others. The Safety Messages specifically address the level of exposure to the operator, and are preceded by one of three words: **DANGER**, **WARNING**, or **CAUTION**.

DANGER

You **WILL** be **KILLED** or **SERIOUSLY INJURED** if you **DO NOT** follow these directions.

WARNING

You **CAN** be **KILLED** or **SERIOUSLY INJURED** if you **DO NOT** follow these directions.

CAUTION

You **CAN** be **INJURED** if you **DO NOT** follow these directions.

Potential hazards associated with the MT-60H-H2 tamping rammer operation will be referenced with Hazard Symbols which appear throughout this manual, and will be referenced in conjunction with Safety Message Alert Symbols.

HAZARD SYMBOLS

Lethal Exhaust Gases



Engine exhaust gases contain poisonous carbon monoxide. This gas is colorless and odorless, and can cause death if inhaled. **NEVER** operate this equipment in a confined area or enclosed structure that does not provide ample free flow air.

Explosive Fuel



GASOLINE is extremely flammable, and its vapors can cause an explosion if ignited. **DO NOT** start the engine near spilled fuel or combustible fluids. **DO NOT** fill the fuel tank while the engine is running or hot. **DO NOT** overfill tank, since spilled fuel could ignite if it comes into contact with hot engine parts or sparks from the ignition system. Store fuel in approved containers, in well-ventilated areas and away from sparks and flames. **NEVER** use fuel as a cleaning agent.

Burn Hazards



Engine components can generate extreme heat. To prevent burns, **DO NOT** touch these areas while the engine is running or immediately after operations. Never operate the engine with heat shields or heat guards removed.

Rotating Parts



NEVER operate equipment with covers, or guards removed. Keep fingers, hands, hair and clothing away from all moving parts to prevent injury.

MT-60H-H2— SAFETY MESSAGE ALERT SYMBOLS



Accidental Starting



OFF

ALWAYS place the engine ON/OFF switch in the **OFF** position, when the reversible plate compactor is not in use.



Respiratory Hazard



ALWAYS wear approved respiratory protection.



Sight and Hearing hazard

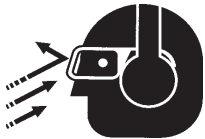

ALWAYS wear approved eye and hearing protection.



Equipment Damage Messages

Other important messages are provided throughout this manual to help prevent damage to your reversible plate compactor, other property, or the surrounding environment.

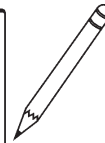
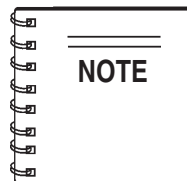

This reversible plate compactor, other property, or the surrounding environment could be damaged if you do not follow instructions.

MT-60H/H2 — RULES FOR SAFE OPERATION

CAUTION

Failure to follow instructions in this manual may lead to serious injury or even death! This equipment is to be operated by trained and qualified personnel only! This equipment is for industrial use only.

The following safety guidelines should always be used when operating the MQ Mikasa MT-60H-H2 Tamping Rammer:

GENERAL SAFETY

- **DO NOT** operate or service this equipment before reading this entire manual.



- This equipment should not be operated by persons under 18 years of age.

- **NEVER** operate this equipment without proper protective clothing, shatterproof glasses, steel-toed boots and other protective devices required by the job.



- **NEVER** operate this equipment when not feeling well due to fatigue, illness or taking medicine.



- **NEVER** operate this equipment under the influence of drugs or alcohol.



- **ALWAYS** check the machine for loosened threads or bolts before starting.

- **ALWAYS** wear proper respiratory (mask), hearing and eye protection equipment when operating the rammer.



- Whenever necessary, replace nameplate, operation and safety decals when they become difficult to read.

- Manufacture does not assume responsibility for any accident due to equipment modifications.

- **NEVER** use accessories or attachments, which are not recommended by Multiquip for this equipment. Damage to the equipment and/or injury to user may result.

- **NEVER** touch the hot exhaust manifold, muffler or cylinder. Allow these parts to cool before servicing engine or rammer.



- **High Temperatures** – Allow the engine to cool before adding fuel or performing service and maintenance functions. Contact with *hot* components can cause serious burns.

- The engine section of this rammer requires an adequate free flow of cooling air. **NEVER** operate the rammer in any enclosed or narrow area where free flow of the air is restricted. If the air flow is restricted it will cause serious damage to the rammer or engine and may cause injury to people. Remember the rammer's engine gives off

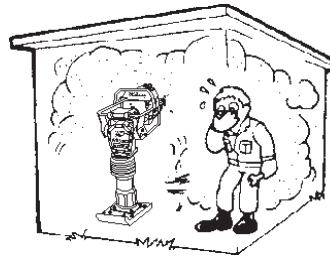

- **ALWAYS** refuel in a well-ventilated area, away from sparks and open flames.

- **ALWAYS** use extreme caution when working with **flammable** liquids. When refueling, **stop the engine** and allow it to cool. **DO NOT** smoke around or near the machine. Fire or explosion could result from fuel vapors, or if fuel is spilled on a hot engine.

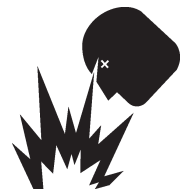

- **NEVER** operate the rammer in an explosive atmosphere or near combustible materials. An explosion or fire could result causing severe **bodily harm or even death**.

MT-60H/H2 — RULES FOR SAFE OPERATION

- **NEVER** Run engine without air filter. Severe engine may occur.
- Always service air cleaner frequently to prevent carburetor malfunction.
- Always be sure the operator is familiar with proper safety precautions and operations techniques before using rammer.
- Always store equipment properly when it is not being used. Equipment should be stored in a clean, dry location out of the reach of children.
- **NEVER** use accessories or attachments, which are not recommended by Multiquip for this equipment. Damage to the equipment and/or injury to user may result.
- **NEVER** Run engine without air cleaner. Severe engine damage may occur.
- Always read, understand, and follow procedures in Operator's Manual before attempting to operate equipment.
- Always be sure the operator is familiar with proper safety precautions and operations techniques before using pump.
- Always store equipment properly when it is not being used. Equipment should be stored in a clean, dry location out of the reach of children.
- Refer to the **ROBIN Engine Owner's Manual** for engine technical questions or information recommended by Multiquip for this equipment. Damage to the equipment and/or injury to user may result.

Transporting

- Always shutdown engine before transporting.
- Tighten fuel tank cap securely and close fuel cock to prevent fuel from spilling.
- Drain fuel when transporting rammer over long distances or bad roads.
- When placing the rammer inside a truck-bed for transport, always tie-down the rammer.

Emergencies

- **ALWAYS** know the location of the nearest **fire extinguisher**.



- **ALWAYS** know the location of the nearest and **first aid kit**.



- In emergencies, **always** know the location of the nearest phone or **keep a phone on the job site**. Also know the phone numbers of the nearest **ambulance, doctor** and **fire department**. This information will be invaluable in the case of an emergency.

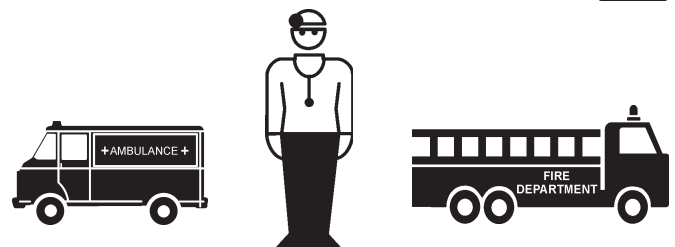

Maintenance Safety

- **NEVER** lubricate components or attempt service on a running machine.
- **ALWAYS** allow the machine a proper amount of time to cool before servicing.
- Keep the machinery in proper running condition.
- Fix damage to the machine immediately and always replace broken parts.
- Dispose of hazardous waste properly. Examples of potentially hazardous waste are used motor oil, fuel and fuel filters.
- **DO NOT** use food or plastic containers to dispose of hazardous waste.
- **DO NOT** pour waste, oil or fuel directly onto the ground, down a drain or into any water source.

MT-60H/H2 — OPERATION AND SAFETY DECALS



P/N 920106460

USE MIXED FUEL ONLY
1/3 PT OUTBOARD OIL: 1 GAL. GAS

NPA-50

P/N 920200910

NAMEPLATE

CONTACT MULTIQUIP
SERVICE DEPT.

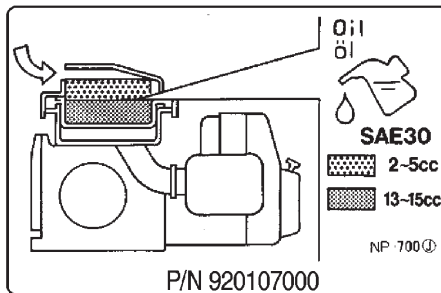

P/N 920107000

CAUTION !

- READ OWNER'S SERVICE MANUAL BEFORE OPERATING OR SERVICING THIS MACHINE.
- ALWAYS KEEP UNAUTHORIZED, INEXPERIENCED, UNTRAINED PEOPLE AWAY FROM THIS MACHINE.
- MAKE SURE ALL SAFETY DEVICES ARE OPERATIONAL BEFORE THIS MACHINE IS STARTED. MAKE SURE ENGINE IS TURNED OFF AND SPARK PLUG WIRE DISCONNECTED BEFORE SERVICING THE MACHINE OR COMING IN CONTACT WITH ANY MOVING PART. IF EQUIPMENT IS POWERED BY AN ELECTRIC MOTOR, DISCONNECT ELECTRICAL PLUG.
- NEVER LEAVE MACHINE UNATTENDED WHEN OPERATING. ALWAYS STOP ENGINE AND ALLOW ENGINE TO COOL BEFORE ADDING FUEL OR OIL.

NPA-329

P/N 920203290

First, remove the element from the pre-cleaner located at the top of the machine. Clean the element with solvent. Apply SAE-30 motor oil as follows: top element (yellow) with 2 to 5 cc and the bottom element (gray) with 13 to 15 cc. Be sure to squeeze out excess oil before reinstalling.

NPA 437

P/N 920204370

**SAE 10W-30
MOTOR OIL**

P/N 920201950

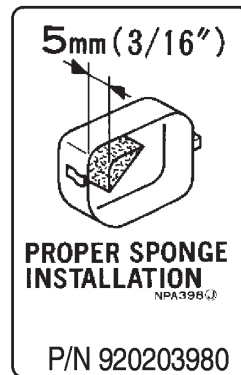

**PROPER SPONGE
INSTALLATION**

P/N 920203980

3650 ~ 3850 RPM

NPA 90

P/N 920203540

When you stop
the engine, be
sure to close
the fuel cock.

NPA-398

P/N 920203990

CAUTION

1. Check all bolts and nuts for tightness
2. Before operation, check oil level at the gauge located on the back side of the protect sleeve. If not enough, fill with motor oil (SAE 10W-30 to maintain specific oil level).
3. Fill the fuel tank with a fuel mixture of gasoline and outboard oil (25:1) 1/3 pint outboard oil to 1 gal. regular gas.
4. To start engine, open fuel filter located under the fuel tank. close choke lever on carburetor and pull starter rope. When engine starts, open choke fully.
5. when difficult to start engine up, open the drain cock located on lower part of crankcase and discharge excess fuel by cranking the engine two or three times.
6. Allow the engine to warm up for 4 to 5 minutes before operation.
7. When starting to operate the machine, move the throttle lever on the handle quickly from "off" to "on" position.
8. Be sure the fuel filter is closed after operation to avoid irregular jumping.

NPA-91

P/N 920205810

Definition of Tamping Rammer

The MQ Mikasa MT-60H/H2 tamping rammer is a powerful compacting tool capable of applying a tremendous force in consecutive impacts to a soil surface. Its applications include soil compacting for road, embankments and reservoirs as well as backfilling for gas pipelines, water pipelines and cable installation work.

The impact force of the MT-60H/H2 levels and uniformly compacts voids between soil particles to increase dry density.

Circular motion is converted to create impact force. The MT-60H/H2 tamping rammer develops a powerful compacting force at the foot of the rammer. To maintain optimum performance, proper operation and service are essential.

Construction of Tamping Rammer

The MQ Mikasa MT-60H/H2 Tamping Rammer is equipped with an Robin air cooled, four cycle gasoline engine. Transmission of the power takes place by increasing the engine speed to engage the centrifugal clutch.

Rammer Gearbox and Spring Cylinder

The MQ Mikasa MT-60H/H2 uses an oil bath lubrication system. Always check the oil level through the oil level sight glass at the rear of the tamper foot.

Controls

Before starting the MT-60H/H2 Tamping Rammer, identify and understand the function of the controls, see Figure 1.

Table 1. MT-60H/H2 Rammer Specifications

MODEL	MT-60H/H2 U.S. (metric)
Overall Height	38.6 in. (980 mm)
Overall Width	14.6 in (370 mm)
Over Length	26.0 in (660 mm)
Shoe Size	10.4 in. (265 mm)
Blows/minute	675
Impact Force	2,200 lbs./blow (1,000 kg/blow)
Impact Stroke	3.0 in (75 mm)
Lubricating Oil (LOW-30)	1.42 pt. (670 cc)
Fuel Tank Capacity	0.8 Gallon (3 liters)
Operating Weight	119 lbs. (54 kg)

Table 2. Robin EC-08GH STD Engine Specifications

MODEL	ROBIN EC-08GH STD ENGINE
Type	Air-Cooled 2 Stroke Gasoline Engine
Piston Displacement	5.12 cu.in. (78.5 cc)
Max. Output	3.3 hp/5,500 rpm (2.46 KW)
Max. Governed Speed, No Load	3,800 rpm
Cooling System	Air-Cooled
Lubrication System	Fuel-Lubrication Oil Spraying System
Number of Cylinders	1
Fuel Mixture	Gasoline and 2-Stroke Oil
Starting System	Recoil Starter

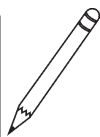
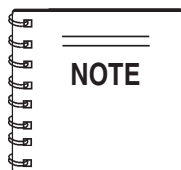

Specifications are general and are subject to change without notice. If exact measurements are required, equipment should be weighed and measured.

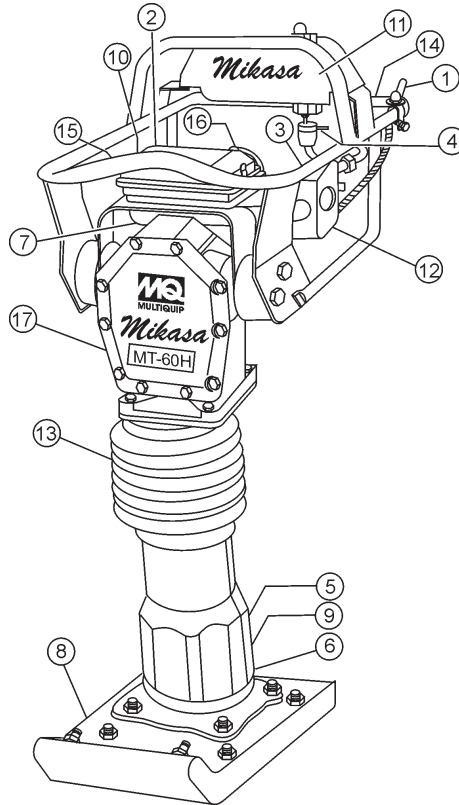

Figure 1. MT-60H/H2 Tamping Rammer

Figure 1 shows the location of the controls and components for the MT-60H/H2 Tamping Rammer. The functions of each control is described below:

1. **Throttle Lever** – Controls engine speed and the tamping action of the rammer.
2. **Engine Stop Switch** – Controls the starting and stopping of the engine. Switch must be in the "ON" position when starting the engine.
3. **Choke Lever** – Used when starting the engine. Normally used in cold weather conditions. In cold weather turn the choke lever to the fully closed position, in warm weather set choke lever half way or completely open.
4. **Fuel Shut-Off Valve** – Supplies fuel from the fuel tank to the engine. To begin fuel flow move the fuel shut-off valve downward.
5. **Oil Bath Fill Plug** – Open this plug to add oil to the oil bath reservoir
6. **Drain Valve** – Open this valve to remove oil from the bellows.
7. **Pre-Cleaner** – Pre-cleans (first stage) dirt and other debris from entering the engine.
8. **Foot** – Laminated wood with tempered steel plate for superior shock absorption.
9. **Oil Level Sight Glass** – Indicates the level of oil in the oil bath reservoir.
10. **Recoil Starting Handle** – Used when starting the engine. Pull starter handle sharply and quickly, then return starter handle to starter case before releasing.
11. **Fuel Tank/Cap** – Poly fuel tank to avoid rust and corrosion, remove this cap to add gasoline.
12. **Engine Air Cleaner** – Prevents dirt (second stage) and other debris from entering the engine.
13. **Bellows** – Reservoir for oil bath.
14. **Handle** – To operate rammer **GRIP** handle assembly firmly on both sides.
15. **Muffler** – Used to reduce noise and emissions.
16. **Spark Plug** – Provides spark to the ignition system, replace with engine manufactures recommended type spark plug.
17. **Nameplate** – Displays information regarding the rammer.

This section is intended to assist the operator with the initial start-up of the MT-60H/H2 Tamping Rammer. It is extremely important that this section be read carefully before attempting to operate the rammer.

DO NOT use your rammer until this section is thoroughly understood.

! DANGER

Failure to understand the operation of the MT-60H/H2 Tamping Rammer could result in severe damage to the rammer or personal injury.

Rammer Gearbox and Spring Cylinder Oil Bath

This unit uses an oil bath lubrication system. Perform the following:

1. Check the oil level through the oil level sight glass (Figure 2) at the rear of the tamper foot.

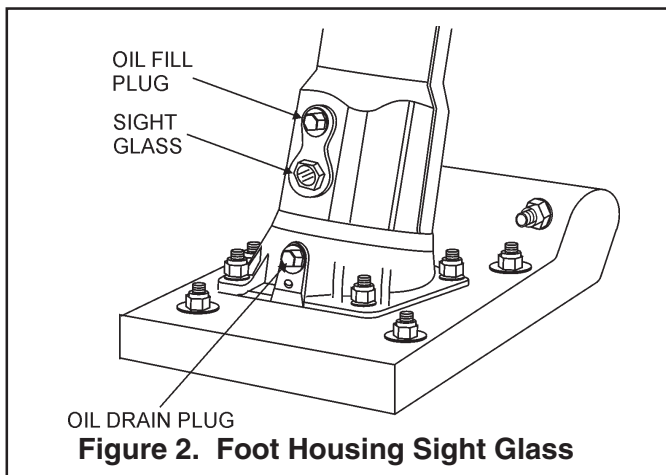

2. If oil is not visible, add 10W-30 motor oil into the oil fill plug opening (Figure 2). The bath contains approximately 1.7 pints (800 cc.)

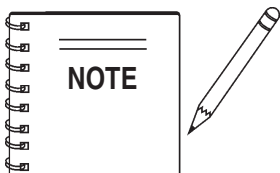

The oil level should be kept at the half way point of the sight glass.

Engine

1. Fill the fuel tank (Figure 3) with unleaded gasoline. At the same time, check the engine oil and make it a habit to replenish it often.

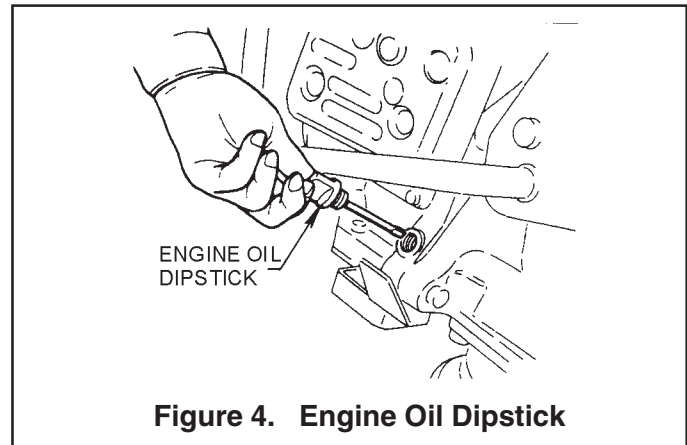
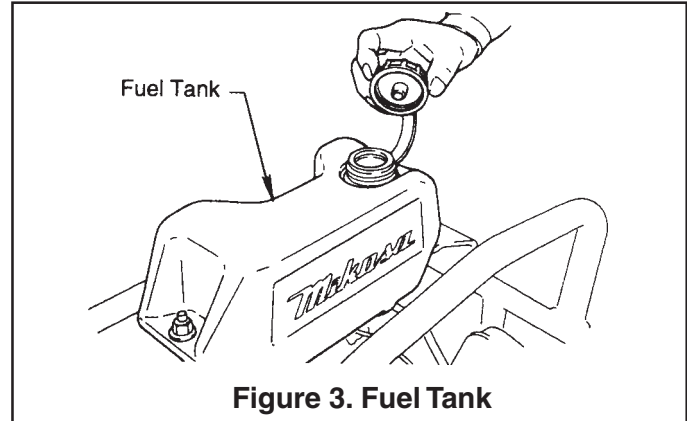

2. Low levels of oil may result in engine seizure due to high levels of consumption during operations.
3. Check the engine oil level and if the engine oil level is low, it should be refilled. Use the proper motor oil as suggested in the Table 3 below.

Table 3 Motor Oil Grade

Season or Temperature	Grade of motor oil (higher than MS class)
Spring, Summer or Autumn +120° F to +15° F	SAE 30
Winter +40° F to +15° F	SAE 30
Below +15° F	SAE 10W-30

Inspection

1. Check all nuts, bolts fasteners for tightness. Retighten as necessary.
2. Clean any dirt from the recoil starter and foot pedestal. Wipe the entire unit clean before operating.
3. Replace any missing or damaged Safety Operation decals.
4. Adjust height of handle. Adjust handle by loosening nuts and moving handle to suit operation. Retighten nuts.

Initial Start-up

When starting the MT-60H/H2 Tamping Rammer perform the following:

1. Open the fuel shut-off valve by moving the **fuel cock** lever to the **open** position (Figure 5).

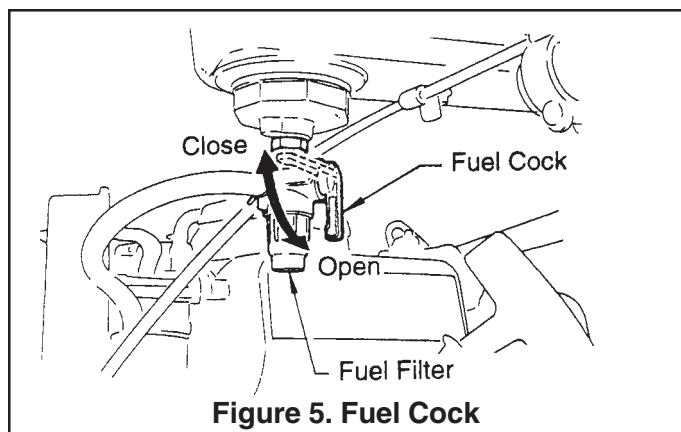

Figure 5. Fuel Cock

2. Set the engine ON/OFF switch (Figure 6) to the "ON" position (start).

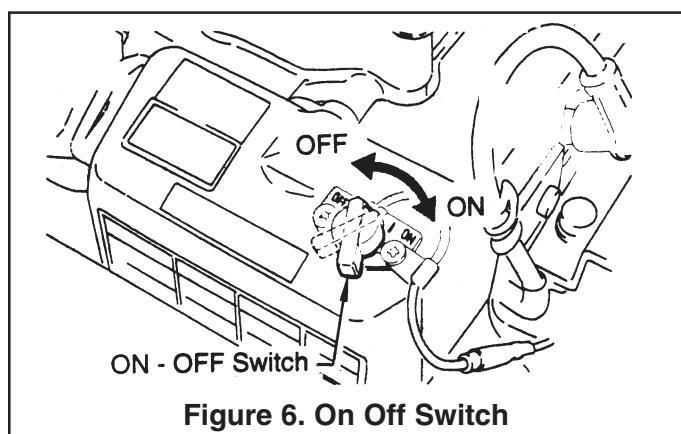

Figure 6. On Off Switch

3. Close the choke lever Figure 7, and move the throttle lever to the "Full Open" position. Turning the choke lever 90 degrees clockwise closes the choke. In cold weather, start the unit with choke fully closed. In warm weather or when the engine is warm, the unit can be started with choke halfway or completely open.

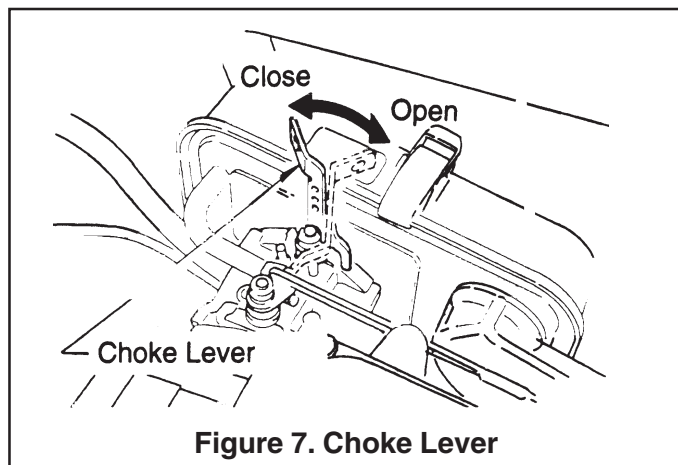

Figure 7. Choke Lever

4. Grip the recoil starter (Figure 8) handle and pull it until you feel a slight resistance. Then pull sharply and quickly. Return the recoil starter handle to the starter case before releasing.

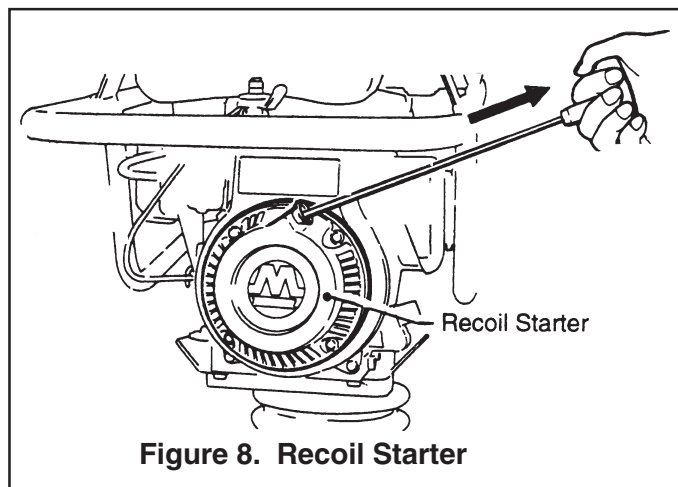

Figure 8. Recoil Starter

5. When the engine starts, move the choke lever slowly to the "FULL OPEN" position. Warm up the engine by running at low speed for three to five minutes, check for gas leakage or abnormal sounds.
6. If the engine does not start after repeated attempts, check the spark plug for excess fuel. Clean and replace the spark plug as needed, then move the choke lever (Figure 7) to the half open position to avoid flooding and repeat steps 1 thru 5.

Operation

1. To start the rammer tamping action, move the throttle lever (Figure 9) quickly from **IDLE** (close) to the **FULL OPEN** position. **DO NOT** move the throttle lever slowly as this may cause damage to the clutch or spring.

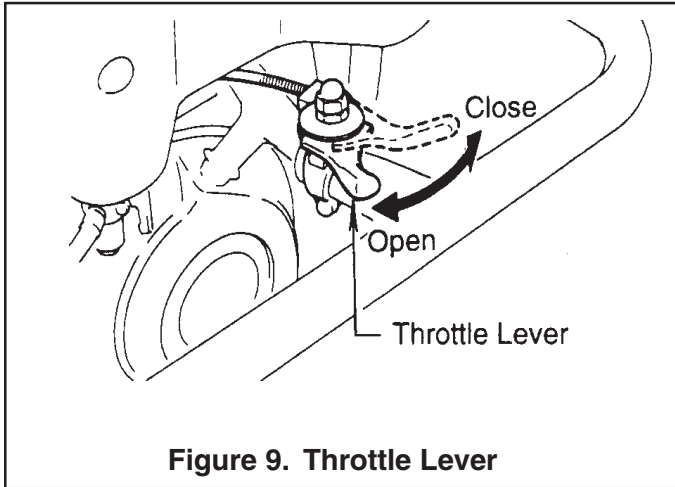

Figure 9. Throttle Lever

CAUTION

Make sure that the throttle lever is moved to the **FULL OPEN** position. Operating the rammer at less than full speeds can result in damage to the clutch springs or foot

2. The MT-60H/H2 Tamping rammer is designed to run at 5,500 rpm. At optimum rpm the foot hits at the rate of 675 impacts per minute. Increasing throttle speed past factory set rpm does not increase impacts and may damage unit. The MT-60H/H2 is designed to advance while tamping. For faster advance, pull back slightly on the handle so that rear of foot contacts soil first.

3. To stop the tamping action, move throttle lever quickly from the **FULL OPEN** to **IDLE** position.

Stopping The Engine

Normal Shutdown

1. Move throttle lever quickly from the **FULL OPEN** to **IDLE** position (Figure 9) and run the engine for three minutes at low speed. After the engine **cools**, turn the engine start/stop switch to the "**STOP**" position (Figure 6) until engine comes to a complete stop.
2. Close the fuel shut-off valve by moving the fuel cock lever to the **CLOSED** position. See Figure 5.

Emergency Showdown

1. Move the throttle lever quickly to the **IDLE** position, and turn the engine start/stop switch to the **STOP** position.

Maintenance

Perform the scheduled maintenance procedures as indicated:

DAILY

- Thoroughly remove dirt and oil from the engine and control area. Clean or replace the air cleaner elements as necessary. Check and retighten all fasteners as necessary. Check the spring box and bellows for oil leaks. Repair or replace as needed.

WEEKLY

- Remove the fuel filter cap and clean the inside of the fuel tank.
- Remove or clean the filter at the bottom of the tank.
- Remove and clean the spark plug, then adjust the spark gap to 0.02~0.03 inch (0.6~0.7 mm). This unit has electronic ignition, which requires no adjustments.
- Clean air cleaner cover.

200 - 300 HOURS (Pre-Cleaner)

- Remove the element from the pre-cleaner (Figure 11) at the top of the crankcase (body side) and clean it with cleaning oil (kerosene).

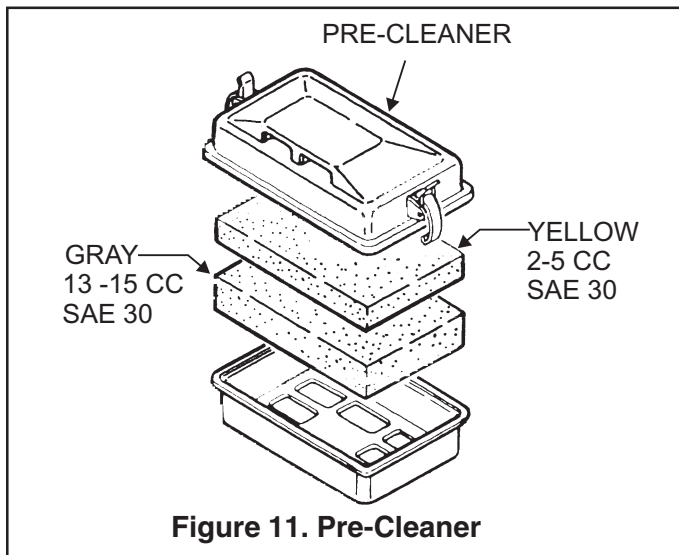

Figure 11. Pre-Cleaner

- Lubricate the top element (yellow) with 2~5 cc of engine oil SAE-30.
- Lubricate bottom element (gray) with 13 ~15 cc of engine oil SAE-30 and completely squeeze out the excess oil from the element before installing.

- The air cleaner (Figure 12) on the engine side will hardly be contaminated, if it is, however after cleaning the element with kerosene, dip it in mixed oil consisting of 3 parts of gasoline and 1 part of engine oil. Then tightly squeeze outer primary element (sponge) and shake off well the inner secondary element before installing them.

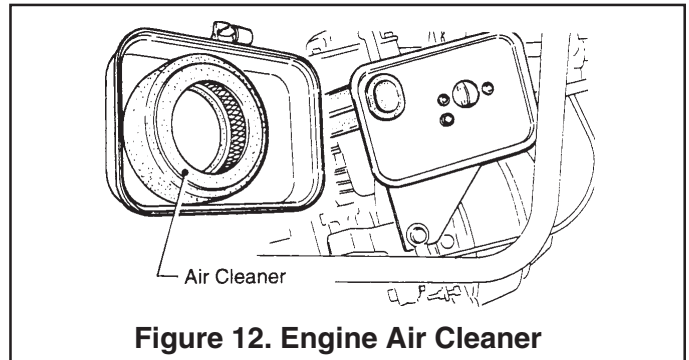

Figure 12. Engine Air Cleaner

200 - 300 HOURS (Oil Bath)

- Drain oil reservoir on foot housing (Figure 13). Refill with approximately 1.7 pt. (800cc) of 10W-30 motor oil. Oil should be midway in sight glass. Break in oil should be changed after first 50 hours.

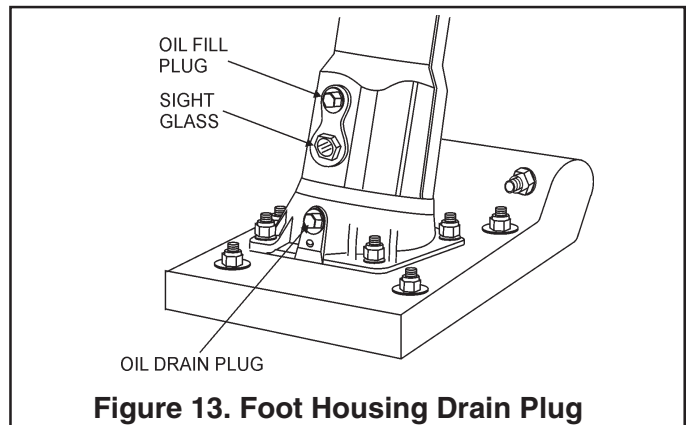

Figure 13. Foot Housing Drain Plug

Yearly

- Check the fuel line and the oil line regularly for damage and to ensure that there are no leaks.
- Replace the oil and fuel lines every two years to maintain the performance and flexibility lines.

Long Term Storage

- Drain fuel from fuel tank, fuel line and carburetor.
- Remove spark plug and pour a few drops of motor oil into cylinder. Crank engine 3 to 4 times so that oil reaches all internal parts.
- Clean exterior with a cloth soaked in clean oil.
- Store unit covered with plastic sheet in moisture free and dust free location out of direct sunlight

MT-60H/H2 — TROUBLESHOOTING GUIDE

TABLE 4. ENGINE TROUBLESHOOTING

SYMPTOM	POSSIBLE PROBLEM	SOLUTION
Difficult to start		
Fuel is available but spark plug will not ignite. (Power available at high tension cable).	Ignition plug being bridge?	Check ignition system.
	Carbon deposit at ignition?	Clean or replace ignition.
	Short circuit due to defective insulators?	Replace insulators.
	Improper spark gap?	Set spark plug gap to the correct gap.
Fuel is available but spark plug will not ignite. (Power NOT available at high tension cable).	Short circuit at stop switch?	Check stop switch circuit. Replace stop switch if defective.
	Ignition coil defective?	Replace ignition coil.
Fuel is available and spark plug ignites (compression normal).	Muffler clogged with carbon deposits?	Clean or replace muffler.
	Mixed fuel quality is inadequate?	Check fuel to oil mixture.
	Fuel in use inadequate (water, dust)?	Flush fuel sytem and replace with fresh fuel.
	Air Cleaner clogged?	Clean or replace air cleaner.
Fuel is available and spark plug ignites (compression low).	Defective cylinder head gasket?	Tighten cylinder head bolts or replace head gasket.
	Cylinder worn?	Replace cylinder.
	Spark plug loose?	Tighen spark plug.
Operation not satisfactory		
Not enough power available (compression normal, no miss-firing).	Air cleaner clogged?	
	Air in fuel line?	Bleed (remove air) from fuel line.
	Fuel level in carbureator float chamber improper?	Adjust carbureator float
	Carbon deposits in cylinder?	Clean or replace cylinder
Not enough power available (compression normal, miss-firing).	Ignition coil defective?	Flush fuel sytem and replace with fresh fuel.
	Ignition plug often shorts?	Replace ignition wires, clean ignition.
	Fuel in use inadequate (water, dust)?	Flush fuel sytem and replace with fresh fuel.
Engine overheats.	Mixed fuel quality is inadequate?	Check fuel to oil mixture.
	Excessive carbon depostion in combustion chamber?	Clean or replace crankcase.
	Exhaust or muffler clogged with carbon.	Clean or replace muffler.
	Spark plug heat value incorrect?	Replace spark plug with correct type spark plug.

MT-60H/H2 — TROUBLESHOOTING GUIDE

TABLE 4. ENGINE TROUBLESHOOTING (continued)

SYMPTOM	POSSIBLE PROBLEM	SOLUTION
Operation not satisfactory		
Rotational speed fluctuates.	Governor adjustment improper?	Adjust governor to correct lever.
	Governor spring defective?	Clean or replace ignition.
	Fuel flow erratic?	Check fuel line.
	Air taken in through suction line?	Check suction line.
Recoil starter not working properly.	Dust in rotating part?	Clean recoil starter assembly.
	Spring spring failure?	Replace sprial spring.

TABLE 5. RAMMER TROUBLESHOOTING

SYMPTOM	POSSIBLE PROBLEM	SOLUTION
Engine rotates but amplituide not uniform or does not strike.	Operating speed of throttle lever is incorrectly set?	Set throttle lever to correct position.
	Oil in excess?	Drain excess oil. Bring to correct level.
	Clutch slips?	Replace or adjust clutch.
	Spring Failure?	Replace sprial spring.
	Speed of engine improper?	Adjust engine speed to correct operating RPM setting.

MT-60H/H2— EXPLANATION OF CODE IN REMARKS COLUMN

The following section explains the different symbols and remarks used in the Parts section of this manual. Use the help numbers found on the back page of the manual if there are any questions.

The contents and part numbers listed in the parts section are subject to change **without notice**. Multiquip does not guarantee the availability of the parts listed.

Sample Parts List:

NO.	PART NO.	PART NAME	QTY.	REMARKS
1	12345	BOLT	1	INCLUDES ITEMS W/*
2*		WASHER, 1/4 IN.		NOT SOLD SEPARATELY
2*	12347	WASHER, 3/8 IN.	1	MQ-45T ONLY
3	12348	HOSE	A/R ..	MAKE LOCALLY
4	12349	BEARING	1	S/N 2345B AND ABOVE

NO. Column

Unique Symbols - All items with same unique symbol (*, #, +, %, or >) in the number column belong to the same assembly or kit, which is indicated by a note in the "Remarks" column.

Duplicate Item Numbers - Duplicate numbers indicate multiple part numbers are in effect for the same general item, such as different size saw blade guards in use or a part that has been updated on newer versions of the same machine.

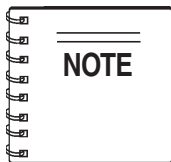

When ordering a part that has more than one item number listed, check the remarks column for help in determining the proper part to order.

PART NO. Column

Numbers Used - Part numbers can be indicated by a number, a blank entry, or TBD.

TBD (To Be Determined) is generally used to show a part that has not been assigned a formal part number at time of publication.

A blank entry generally indicates that the item is not sold separately or is not sold by Multiquip. Other entries will be clarified in the "Remarks" Column.

QTY. Column

Numbers Used - Item quantity can be indicated by a number, a blank entry, or A/R.

A/R (As Required) is generally used for hoses or other parts that are sold in bulk and cut to length.

A blank entry generally indicates that the item is not sold separately. Other entries will be clarified in the "Remarks" Column.

REMARKS Column

Some of the most common notes found in the "Remarks" Column are listed below. Other additional notes needed to describe the item can also be shown.

Assembly/Kit - All items on the parts list with the same unique symbol will be included when this item is purchased.

Indicated by:

"INCLUDES ITEMS W/(unique symbol)"

Serial Number Break - Used to list an effective serial number range where a particular part is used.

Indicated by:

"S/N XXXXX AND BELOW"

"S/N XXXX AND ABOVE"

"S/N XXXX TO S/N XXX"

Specific Model Number Use - Indicates that the part is used only with the specific model number or model number variant listed. It can also be used to show a part is NOT used on a specific model or model number variant.

Indicated by:

"XXXXX ONLY"

"NOT USED ON XXXX"

"Make/Obtain Locally" - Indicates that the part can be purchased at any hardware shop or made out of available items. Examples include battery cables, shims, and certain washers and nuts.

"Not Sold Separately" - Indicates that an item cannot be purchased as a separate item and is either part of an assembly/kit that can be purchased, or is not available for sale through Multiquip.

MT-60H/H2— SUGGESTED SPARE PARTS

MT-60H/H2 RAMMER 1 TO 3 UNITS

Qty.	P/N	Description
1	956225020	LEVER, THROTTLE
3	354030030	ELEMENT, YELLOW
3	354030040	ELEMENT, GRAY
1	361910020	CAP, FUEL TANK W/ STRAP
1	954405990	COCK, FUEL ASSY.
1	954404890	FILTER, FUEL TANK
2	301419750	FILTER, IN-LINE FUEL
3	2743261007	ELEMENT, SET ENGINE
1	066000361	BUTTON, STOP
3	0650140460	SPARK PLUG
1	954406010	STRAINER, FUEL TANK
1	956106040	THROTTLE , WIRE

MT-60H/H2 RAMMER 3 TO 5 UNITS

Qty.	P/N	Description
1	956225020	LEVER, THROTTLE
1	956106040	THROTTLE WIRE
5	354030030	ELEMENT, YELLOW
5	354030040	ELEMENT, GRAY
2	351316870	CLAMP, BELLOWS
1	353332870	BELLOWS
1	361910020	CAP, FUEL TANK W/ STRAP
1	954405990	COCK, FUEL ASSY.
2	954404890	FILTER, FUEL TANK
5	301419750	FILTER, IN-LINE FUEL
5	2743261007	ELEMENT SET ENGINE
1	0660000361	BUTTON, STOP
5	0650140460	SPARK PLUG

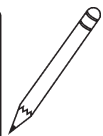
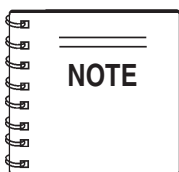

Part number on this Suggested Spare Parts List may super cede/replace the P/N shown in the text pages of this book.

MT-60H/H2 RAMMER 5 TO 10 UNITS

Qty.	P/N	Description
2	956225020	LEVER, THROTTLE
2	956106040	THROTTLE WIRE
6	354030030	ELEMENT, YELLOW
6	354030040	ELEMENT, GRAY
4	351316870	CLAMP, BELLOWS
2	353332870	BELLOWS
2	361910020	CAP, FUEL TANK W/STRAP
2	954405990	COCK, FUEL ASSY.
4	954404890	FILTER, FUEL TANK
6	301419750	FILTER, IN-LINE FUEL
3	2743261007	ELEMENT SET ENGINE
3	0660000361	BUTTON, STOP
10	0650140460	SPARK PLUG
2	954406010	STRAINER, FUEL TANK
2	2741550103	GASKET, COMPLETE HEAD
2	2303520101	GASKET, COMPLETE EXHAUST
1	2303262008	GASKET, AIR CLEANER
1	2746230100	CARBURETOR ASSEMBLY
1	050100800	O-RING, UPPER GUIDE CYLINDER
2	050100950	O-RING, MIDDLE GUIDE CYLINDER
1	050930850	O-RING, LOWER GUIDE CYLINDER
1	050100750	O-RING, FOOT PLATE GUIDE CYLINDER

MT-60H/H2 RAMMER 10+ UNITS

Qty.	P/N	Description
4	956225020	LEVER, THROTTLE
4	956106040	THROTTLE WIRE
10	354030030	ELEMENT, YELLOW
10	354030040	ELEMENT, GRAY
8	351316870	CLAMP, BELLOWS
4	353332870	BELLOWS
4	361910020	CAP, FUEL TANK W/ STRAP
4	954405990	COCK, FUEL ASSY.
6	954404890	FILTER, FUEL TANK
10	301419750	FILTER, IN-LINE FUEL
10	2743261007	ELEMENT SET ENGINE
4	0660000361	BUTTON, STOP
16	0650140460	SPARK PLUG
1	2747020101	IGNITION COIL
3	2741550103	GASKET, COMPLETE HEAD
3	2303520101	GASKET, COMPLETE EXHAUST
3	2303262008	GASKET, AIR CLEANER
1	301421363	CLUTCH ASSY
1	2746230100	CARBURETOR ASSEMBLY
1	2745020100	RECOIL STARTER ASSEMBLY
2	050100800	O-RING, UPPER GUIDE CYLINDER
4	050100950	O-RING, MIDDLE GUIDE CYLINDER
2	050930850	O-RING, LOWER GUIDE CYLINDER
2	050100750	O-RING, FOOT PLATE GUIDE CYLINDER

NAME PLATE AND DECALS

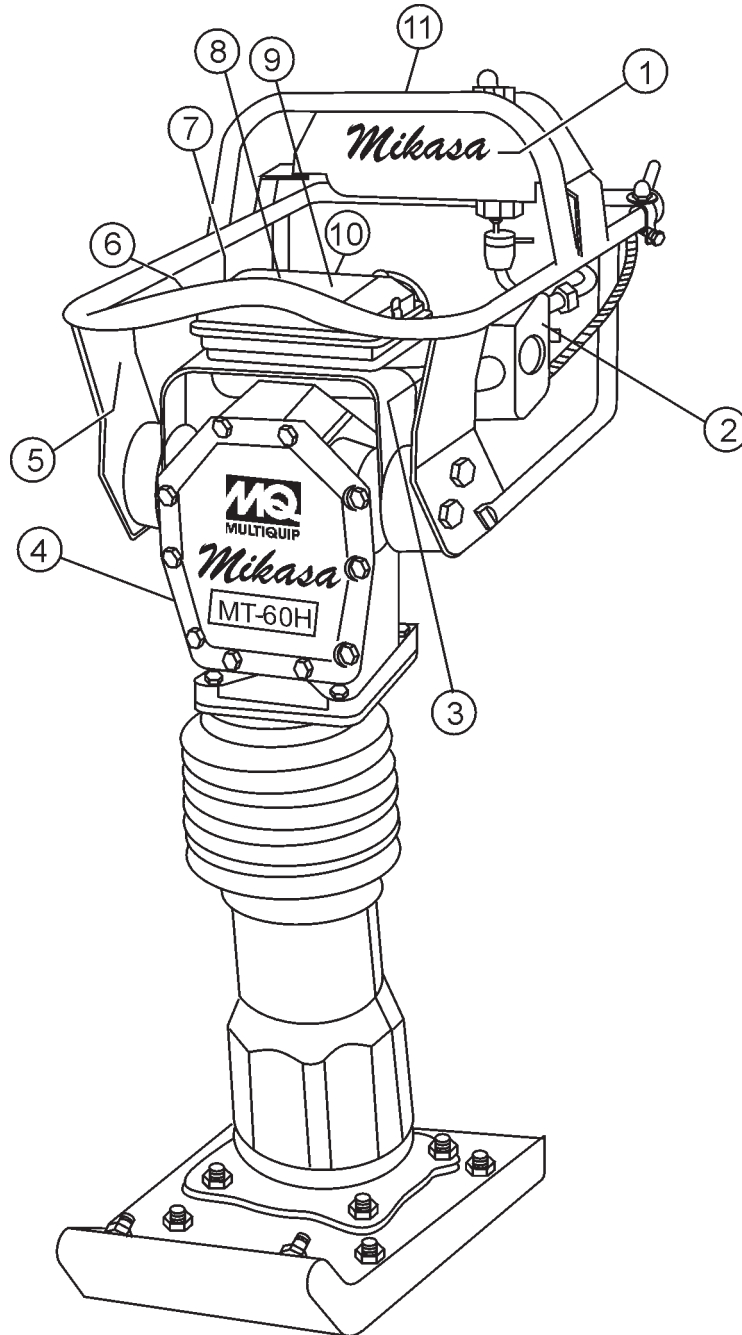

MT-60H/H2— NAMEPLATE/DECAL LOCATION

NAME PLATE AND DECALS

<u>NO.</u>	<u>PART NO.</u>	<u>PART NAME</u>	<u>QTY.</u>	<u>REMARKS</u>
1*	920106460	DECAL: MIKASA MARK	1	
2*	920203980	DECAL: ELEMENT SET	1	
3*	920203290	DECAL: READ OWNER'S MAN.	1	
4		PLATE: SERIAL NO.	1 ORDER FROM MQ SER. DEPT. W/MODEL & S/N
5*	920107000	DECAL: PRE-CLEANER / MT-W	1	
6*	920203540	DECAL ENGINE R.P.M 3850	1	
7*	920203990	DECAL: FUEL COCK	1	
8*	920200910	DECAL: CAUTION	1	
9*	920204370	DECAL: PRE CLEANER	1	
10*	920201950	DECAL MOTOR OIL	1	
11*	920200500	DECAL MIXED FUEL	1	
12	DCLMT60H2	DECAL KIT MT-60H/ 60H2	1 INCLUDES ALL ITEMS W/*

FOR DECAL ILLUSTRATIONS SEE PAGE 10.

MT-60H/H2— CRANKCASE AND ENGINE ASSY.

CRANK CASE AND ENGINE ASSY.(MT60H)

MT-60H

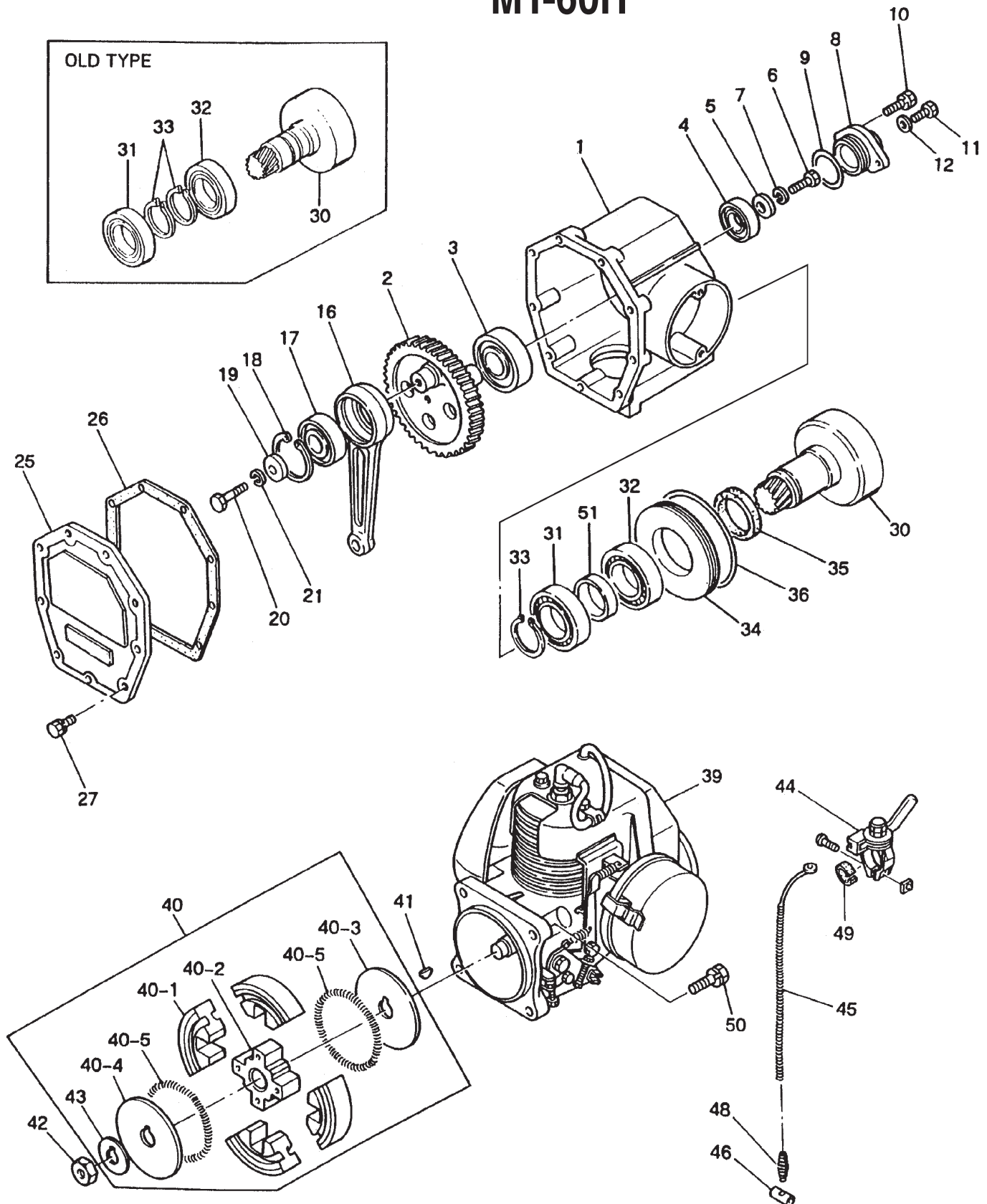

MT-60H/H2 — CRANKCASE AND ENGINE ASSY.

CRANK CASE AND ENGINE ASSY.(MT60H)

<u>NO.</u>	<u>PART NO.</u>	<u>PART NAME</u>	<u>QTY.</u>	<u>REMARKS</u>
1	351109060	CRANK CASE	1	
2	351324110	CRANK GEAR 126D-57Z	1	
3	040006305	BEARING (6305)	1	
4	042506203	BEARING (6203)	1	REPLACES 040006203
5	952401450	WASHER 8.5X22X3	1	
6	011220825	BOLT 8X25 T	1	REPLACES 001220825
7	030208200	SW M8	1	
8	351434561	BEARING COVER	1	
9	050100350	O-RING G-35	1	
10	011706020	BOLT 6X20 H, SW	2	REPLACES 002210620
11	011006010	BOLT 6X10 T	1	DC REPLACES 001220610
12	952404470	WASHER PW M6	1	DC REPLACES 031106100
16	303010060	CONNECTING ROD	1	
17	040006304	BEARING 6304	1	
18	080100520	STOP RING R-52	1	
19	952400130	WASHER 9304	1	
20	011208025	BOLT 8X25 T	1	REPLACES 001220825
21	030208200	WASHER SW M8	1	
25	351209580	FRONT COVER	1	
26	351319880	PACKING, FRONT COVER	1	
27	011706020	BOLT 6X20 H, SW	9	REPLACES 002210620
30	303010084	PINON	1	REPLACES 303010080
31	040006007	BEARING 6007	1	
32	041006007	BEARING 6007Z	1	
33	080200350	STOP RING S-35	2	QC FROM 2 TO 1
34	351421900	SPACER CLUTCH DRUM	1	
35	060404010	OIL SEAL TC-40528	1	
36	050300900	O-RING S-90	1	
39	911100840	ENGINE EC08GH	1	REPLACES 911100825
40	301421363	CLUTCH ASSY	1	INCLS. ITEMS W/* REPLACES 301421360
40-1*	943020020	CLUTCH SHOE	4	
40-2*	943050050	CLUTCH BOSS	1	
40-3*	943060010	CLUTCH GUIDE A	1	
40-4*	943060020	CLUTCH GUIDE B	1	
40-5*	943030020	CLUTCH SPRING	2	
41	0053204201	WOODRUFF KEY	1	
42	0173120010	LOCKNUT	1	
43*	301010210	LOCK WASHER , CLUTCH	1	
44	956300130	THROTTLE LEVER AY25	1	
45	501302060	THROTTLE WIRE	1	REPLACES 301312630
46	959401750	WIRE STOPPER ASSY	1	
48	402010110	RETURN SPRING	1	REPLACES 301010950
49	959403750	RUBBER SLIP STOP	1	
50	002210830	BOLT 8X30 H,SW	1	
51	351437750	SPACER 35.4-42.7-11	1	

MT-60H/H2— CRANKCASE AND ENGINE ASSY.

CRANK CASE AND ENGINE ASSY.(MT60H2)

MT-60H2

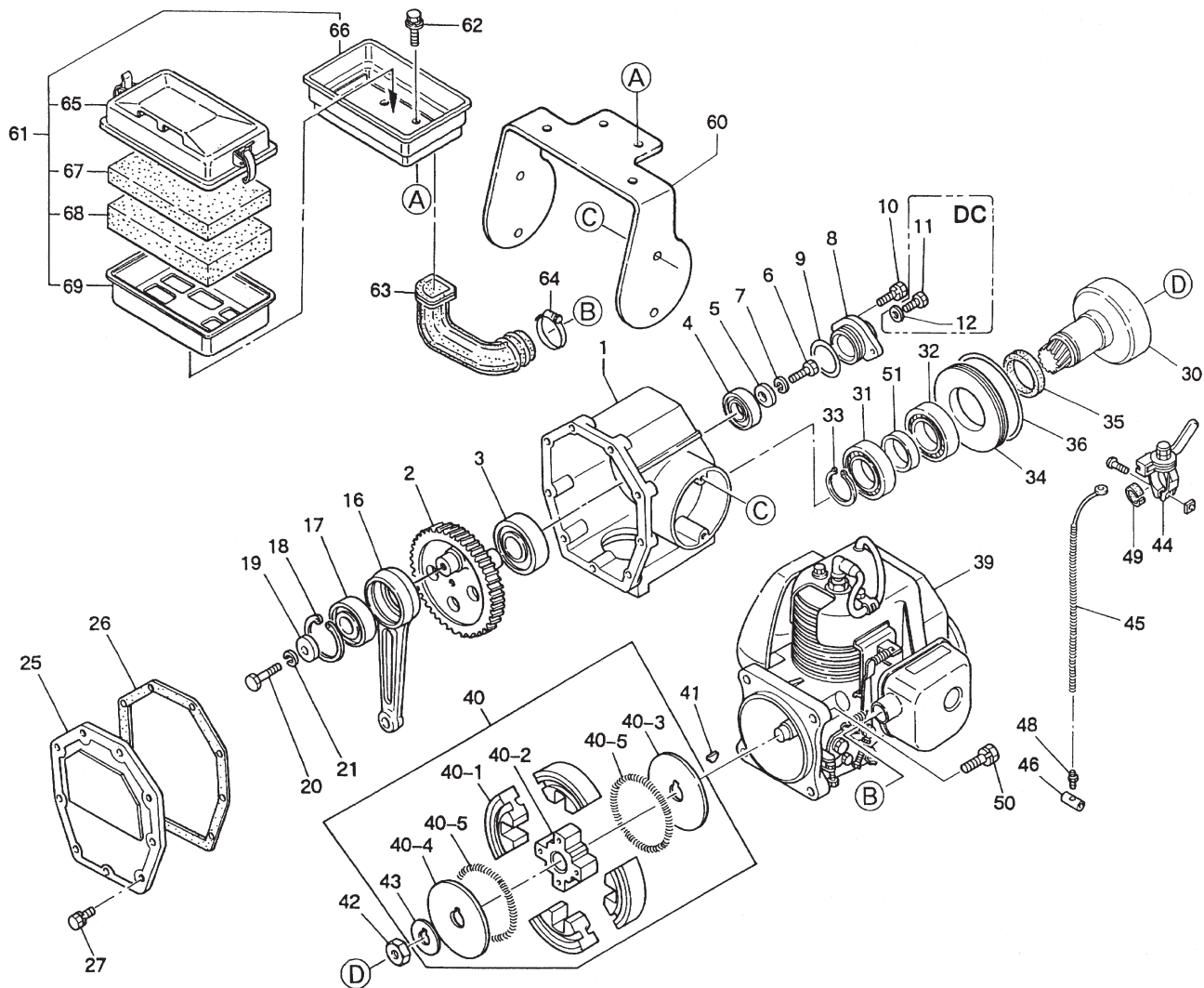

MT-60H/H2— CRANKCASE AND ENGINE ASSY.

CRANK CASE AND ENGINE ASSY.(MT60H2)

<u>NO.</u>	<u>PART NO.</u>	<u>PART NAME</u>	<u>QTY.</u>	<u>REMARKS</u>
1	351109060	CRANK CASE	1	
2	351324110	CRANK GEAR 126D-57Z	1	
3	040006305	BEARING (6305)	1	
4	042506203	BEARING (6203)	1	REPLACES 040006203
5	952401450	WASHER 8.5X22X3	1	
6	011220825	BOLT 8X25 T	1	REPLACES 001220825
7	030208200	WASHER SW M8	1	
8	351434561	BEARING COVER	1	
9	050100350	O-RING G-35	1	
10	011706020	BOLT 6X20 H,SW	2	REPLACES 002210620
11	011006010	BOLT 6X10 T	1	DC REPLACES 001220610
12	952404470	WASHER PW M6	1	DC REPLACES 031106100
16	303010060	CONNECTING ROD	1	
17	040006304	BEARING 6304	1	
18	080100520	STOP RING R-52	1	
19	952400130	WASHER 9304	1	
20	011208025	BOLT 8X25 T	1	REPLACES 001220825
21	030208200	WASHER SW M8	1	
25	351209580	FRONT COVER	1	
26	351319880	PACKING, FRONT COVER	1	
27	011706020	BOLT 6X20 H, SW	9	REPLACES 002210620
30	303010084	PINON	1	REPLACES 303010080
31	040006007	BEARING 6007	1	
32	041006007	BEARING 6007Z	1	
33	080200350	STOP RING S-35	2	QC FROM 2 TO 1
34	351421900	SPACER CLUTCH DRUM	1	
35	060404010	OIL SEAL TC-40528	1	
36	050300900	O-RING S-90	1	
39	911100822	ENGINE EC08GH MT-60H2	1	
40	301421360	CLUTCH ASSY	1	INCLUDES ITEMS W/*
40-1*	943020020	CLUTCH SHOE	4	
40-2*	943050050	CLUTCH BOSS	1	
40-3*	943060010	CLUTCH GUIDE A	1	
40-4*	943060020	CLUTCH GUIDE B	1	
40-5*	943030020	CLUTCH SPRING	2	
41	0053204201	WOODRUFF KEY	1	
42	0173120010	LOCKNUT	1	
43*	301010210	LOCK WASHER , CLUTCH	1	
44	956300130	THROTTLE LEVER ASSY. 25	1	
45	501302060	THROTTLE WIRE	1	REPLACES 301312630
46	959401750	WIRE STOPPER ASSY	1	
48	402010110	RETURN SPRING	1	REPLACES 301010950
49	959403750	RUBBER SLIP STOP	1	
50	002210830	BOLT 8X30 H,SW	1	
51	351437750	SPACER 35.4-42.7-11	1	AD *2
60	353332810	CLEANER STAY	1	
61	354211841	AIR CLEANER AY	1	INCLS. ITEMS W/#
62	011008015	BOLT 8X15 H,SW	4	REPLACES 00210815
63	354330590	INTAKE PIPE	1	
64	507010110	CLAMP TC-200	1	
65#	354030011	BODY	1	REPLACES 354030010
66#	354030020	BACK PLATE	1	
67#	354030030	ELEMENT,YELLOW	1	
68#	354030040	ELEMENT,GRAY	1	
69#	354030050	ELEMENT FRAME	1	

MT-60H/H2 — CYLINDER GUIDE AND FOOT ASSY.

CYLINDER GUIDE AND FOOT ASSY.

<u>NO.</u>	<u>PART NO.</u>	<u>PART NAME</u>	<u>QTY.</u>	<u>REMARKS</u>
61	351420390	PISTON PIN	1	
62	080100120	STOP RING R-12	2	
63	351324120	PISTON ROD	1	
64	351420400	PISTON END	1	
65	020316130	NUT M16 P1.5	1	REPLACES 02016130
66	351434200	STOPPER UPPER	1	
67	351434211	STOPPER LOWER	1	OX
68	351324140	MAIN SPRING A, B	2	
69	351324130	SPRING CYLINDER	1	
70	351209600	FOOT PLATE	1	
71	351109020	PROTECTION SLEEVE	1	
73	050100750	O-RING G-75	1	
74	050930850	O-RING JAS03085	1	
75	014210020	SOCKET HEAD BOLT 10X20 T	4	REPLACES 001521020
76	014210035	SOCKET HEAD BOLT 10X35 T	4	REPLACES 001521035
77	953405270	PLUG 1\4X14 13L	2	
78	953405260	PACKING 1\4 (CU)	2	
82	351209590	GUIDE CYLINDER	1	
83	351324300	BELLOWS (ORANGE)	1	
84	050100950	O-RING G-95	2	
85	351316870	BELLOWS CLAMP	2	
86	351433250	BAND GUIDE \ BELLOWS	2	
87	011008040	BOLT 8X40 T	2	REPLACES 001220840
87	011208035	BOLT 8X35 T	2	OO REPLACES 001220835
88	020108060	NUT M8	2	REPLACES 020308060
89	050100800	O-RING G-80	1	
90	012710040	BOLT 10X40 H, SW	4	REPLACES 002211040
100	351910130	FOOT AY	1	INCLUDES ITEMS W/* 10" (W) X 13 (L)
101*	351109030	FOOT 265W-215P	1	
102*	351109040	METAL SHEET 265W-215P-4.5	1	
103	015112060	SUNK HEAD BOLT 12 X 70 H	4	REPLACES 001611253 & 015112075
			INCLUDES ITEMS W/#
104*	015110055	SUNK HEAD BOLT 10X55	7	INCLUDES ITEMS W/%
105#	021112140	NYLON NUT M12	4	REPLACES 022711214
106	030212300	WASHER SW M12	4	
107*%	022711012	NYLON NUT M10	7	
108*	030210250	WASHER SW M12	7	
109*	352322581	FOOT FITTING	2	REPLACES 352322580
110*	301010540	WASHER 11X34X3.2	1	
112	959010150	LEVEL GAUGE PLUG TYPE	1	
113	953404670	COPPER PACKING 17X25.5X1	1	

MT-60H/H2 — TANK AND HANDLE ASSY.

TANK AND HANDLE ASSY.

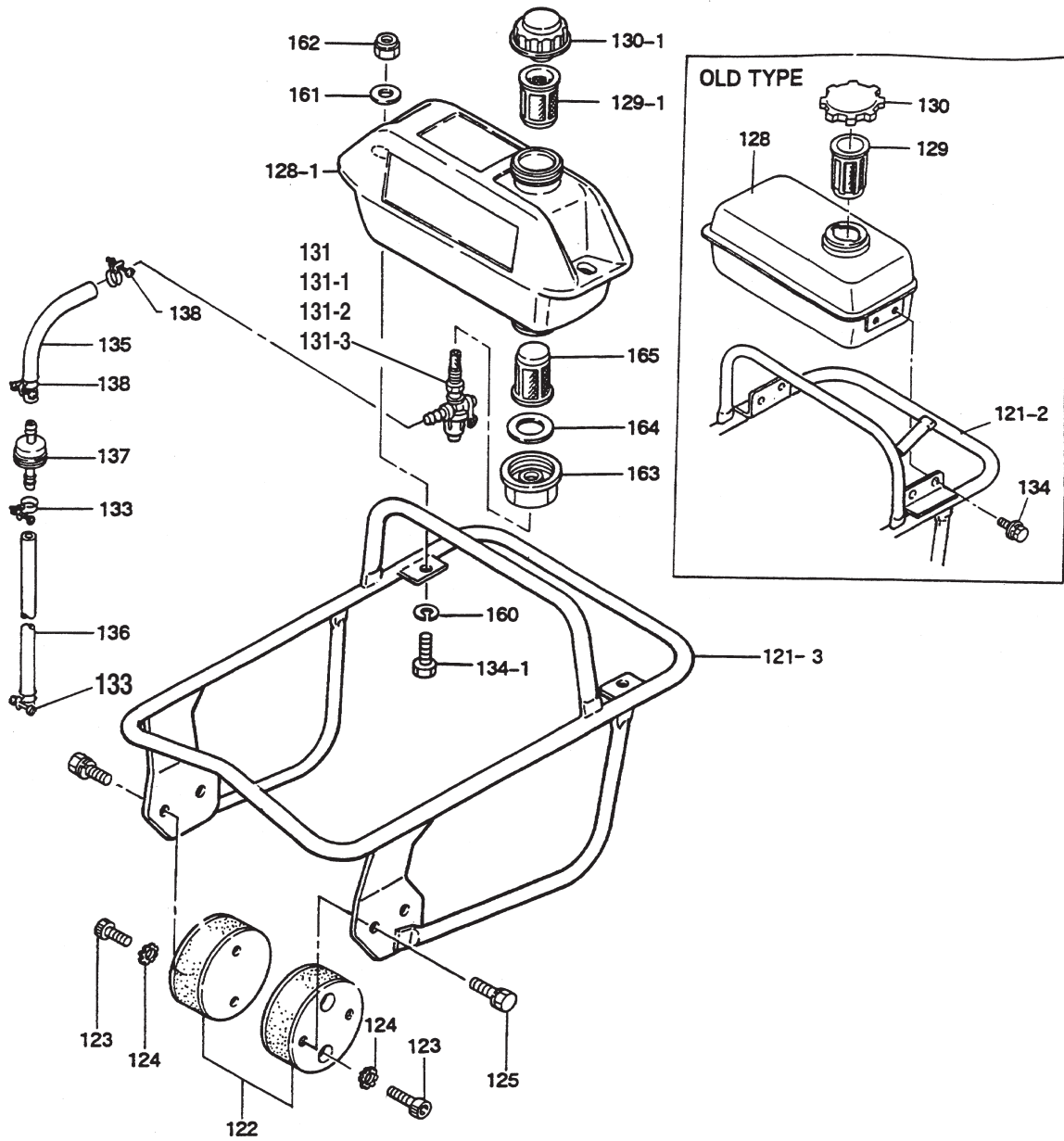

MT-60H/H2 — TANK AND HANDLE ASSY.

TANK AND HANDLE ASSY.

<u>NO.</u>	<u>PART NO.</u>	<u>PART NAME</u>	<u>QTY.</u>	<u>REMARKS</u>
121-2	351109490	HANDLE - MT-60H	1	W/OLD STYPE FUEL TANK
121-3	351111810	HANDLE - MT-60H	1	W/NEW STYLE FUEL TANK
121-3	353112620	HANDLE - MT60H2	1	
122	351319900	SHOCK ABSORBER	2	
123	014210020	SOCKET HEAD BOLT 10X20 T	4	REPLACES 001521020
124	033121009	TOOTHED LOCK WASHER M10 ...	4	REPLACES 001521020
125	002211025	BOLT 10X25 H, SH	4	
125	012210020	BOLT 10X20 H, SW	4	XX REPLACES 002211020
126	303010440	WASHER 11X22X3	4	
128	351010010	FUEL TANK 3.3 (CUBIC)	1	
128-1	351110650	FUEL TANK 3L (P)	1	
129	954405080	FUEL FILTER	1	
129-1	954404890	FILTER TANK	1	
130	0430430015	FUEL TANK CAP	1	REPLACES 953404650
130-1	0430440033	FUEL TANK CAP	1	
131	954300390	FUEL COCK AY	1	INCLUDES ITEMS W/* REPLACES 301322990
131-1*	0642001410	CUP, FUEL COCK	1	
131-2*	0642001420	STRAINER SCREEN, FUEL COCK	1	
131-3*	0642001430	RUBBER PACKING, FUEL COCK	1	
133	954404590	HOSE BAND 9.5 D	2	
134	011808015	BOLT 8X15 H, SW, PW	4	REPLACES 002410815
134-1	011208030	BOLT 8X30 T	2	REPLACES 001220830
135	351434320	FUEL HOSE R-95	1	
135	351436350	FUEL HOSE R-150	1	
136	351435160	FUEL HOSE B-95	1	
137	301419750	FUEL FILTER	1	
138	301420730	HOSE BAND (8)	2	REPLACES 94403030
160	030208200	WASHER SW M8	1	
161	952401450	WASHER 8.5X22X3	2	
162	022710809	NYLON NUT M8	2	
163	351437780	HOLDER COCK HOLDER	1	
164	351439290	PACKING, COCK HOLDER	1	
165	954405080	STRAINER (#100)	1	

MT-60H/H2 —OPTIONAL PARTS (NARROW FOOTS) ASSY.

OPTIONAL PARTS ASSY.

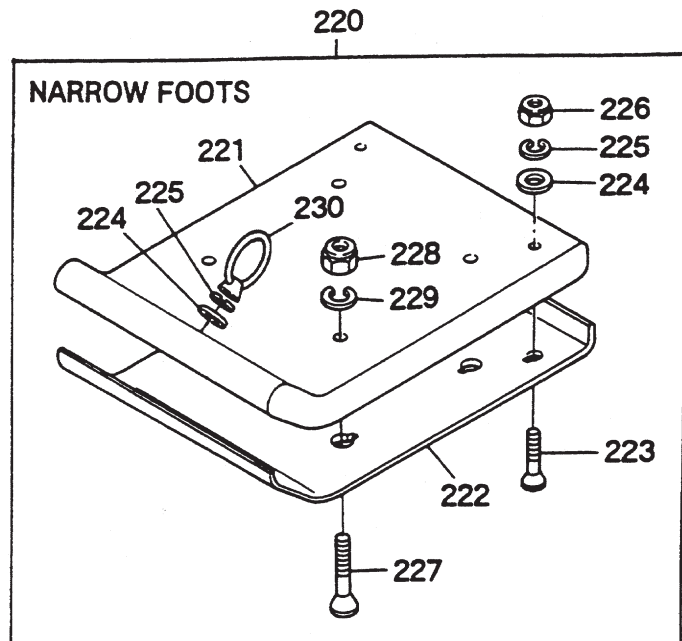
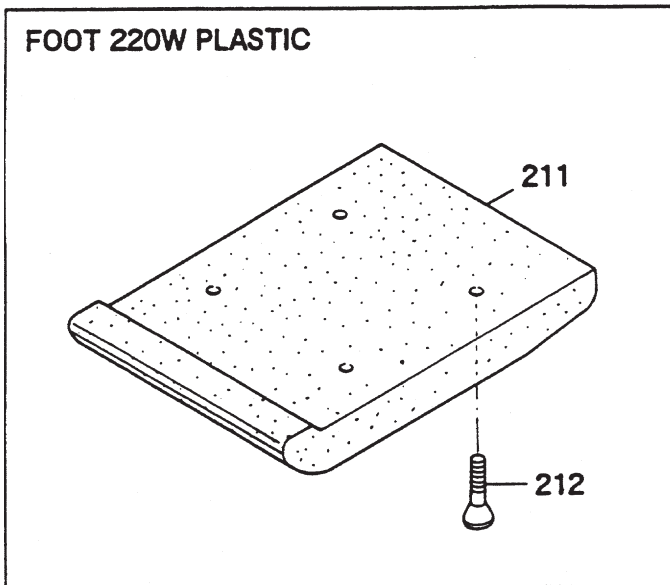

MT-60H/H2 —OPTIONAL PARTS (NARROW FOOT) ASSY.

OPTIONAL PARTS ASSY.

<u>NO.</u>	<u>PART NO.</u>	<u>PART NAME</u>	<u>QTY.</u>	<u>REMARKS</u>
211	3513-23750	FOOT 220W, PLASTIC	1	
212	0151-12080	SUNK HEAD BOLT 12X80H	4	
220	3519-10140	NARROW FOOT ASSY 170W	1	170W
220	3519-10150	NARROW FOOT ASSY 200W	1	200W
220	3519-10160	NARROW FOOT ASSY 220W	1	220W
221	3513-24240	NARROW FOOT ASSY 170W	1	170W
221	3513-24250	NARROW FOOT ASSY 200W	1	200W
221	3519-10160	NARROW FOOT ASSY 220W	1	220W
222	3513-24270	METAL SHEET ASSY 170W	1	170W
222	3513-24280	METAL SHEET ASSY 200W	1	200W
222	3513-24290	METAL SHEET ASSY 220W	1	220W
223	0151-10056	SUNK HEAD BOLT 10X56H	5	
224	3010-10540	WASHER	5	
225	0302-10250	WASHER SW M10	5	
226	0211-10120	NYLON NUT M10	4	
227	0151-12070	SUNK HEAD BOLT 12X70H	4	
228	0211-12140	NYLON NUT M12	4	
229	0302-12300	WASHER SW M12	4	
230	9590-10413	EYE NUT M10	1	

ROBIN EC-08GH ENGINE — CRANKSHAFT AND PISTON ASSY.

CRANKSHAFT AND PISTON ASSY.

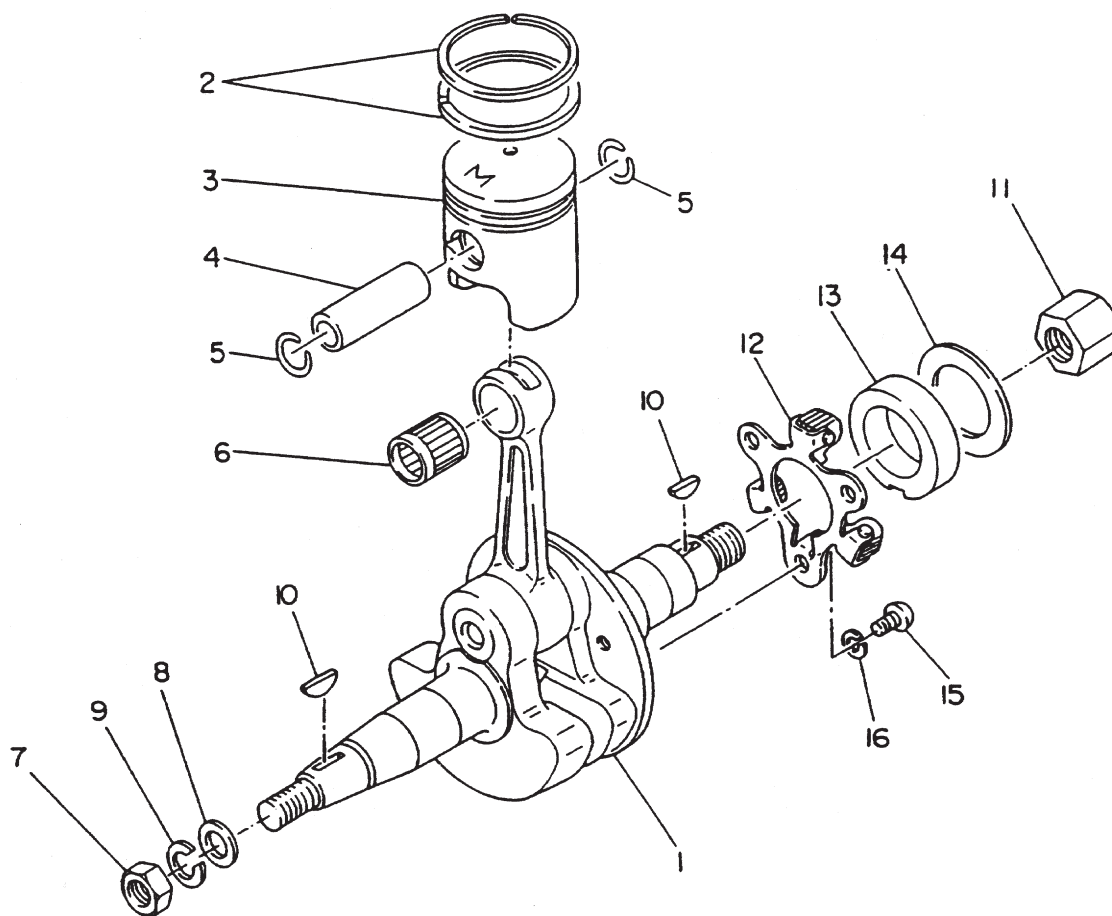

ROBIN EC-08GH ENGINE — CRANKSHAFT AND PISTON ASSY.

CRANKSHAFT AND PISTON ASSY.

<u>NO.</u>	<u>PART NO.</u>	<u>PART NAME</u>	<u>QTY.</u>	<u>REMARKS</u>
1	5802024000	CRANK SHAFT CP	1	
2	5802023000	PISTON RING	2	REPLACES 5802500500
3	5802500600	PISTON	1	
4	5802500700	PISTON PIN	1	
5	0565119990	CLIP	2	
6	0610120010	NEEDLE BEARING	1	
7	0039310000	NUT	1	REPLACES 002181000
8	030206150	WASHER	1	REPLACES 003101000
9	030210250	SPRING WASHER	1	REPLACES 003201000
10	0053204201	WOODRUFF KEY	2	
11	0173120010	ROCK NUT	1	
12	1294170322	GOVERNOR PLATE UNIT	1	
13	5514500100	GOVERNOR SLEEVE	1	
14	0230230020	SPACER	1	
15	0043105080	SCREW (PAN HEAD)	3	
16	0032005000	SPRING WASHER	3	

ROBIN EC-08GH ENGINE — CRANKCASE AND CYLINDER ASSY.

CRANKCASE AND CYLINDER ASSY.

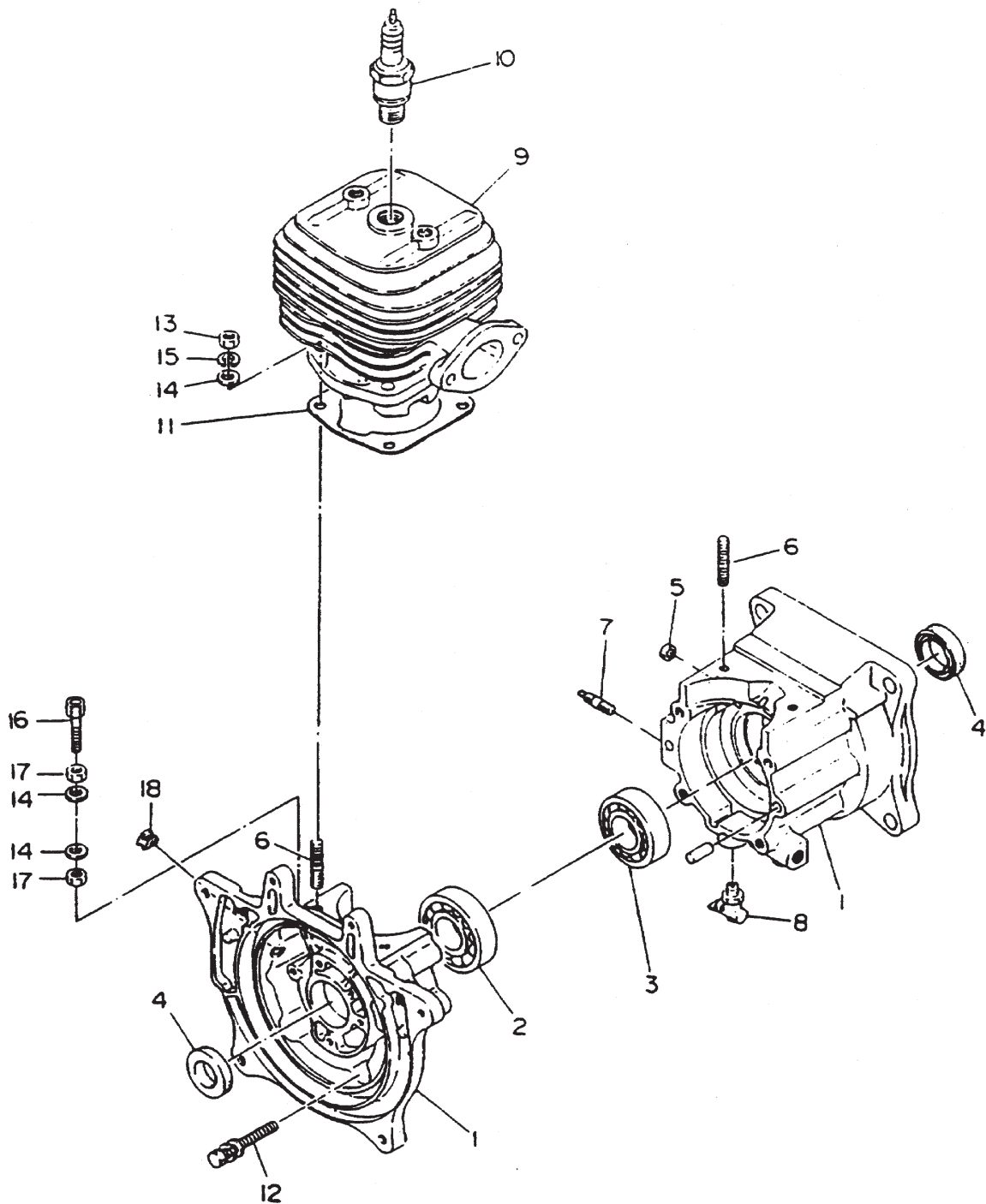

ROBIN EC-08GH ENGINE — CRANKCASE AND CYLINDER ASSY.

CRANKCASE AND CYLINDER ASSY.

<u>NO.</u>	<u>PART NO.</u>	<u>PART NAME</u>	<u>QTY.</u>	<u>REMARKS</u>
1	5801036000	CRANK CASE COMPL.....	1	INCLUDES ITEMS W/*
2*	0600200020	BALL BEARING (6204 C3)	1	
3*	0600200010	BALL BEARING (6004 C3)	1	
4*	0440200020	OIL SEAL	2	
5*	0440060010	OIL SEAL	1	
6*	0105064970	STUD	4	
7*	0105060050	STUD	1	
8	0643109980	DRAIN COCK	1	
9	5801501400	CYLINDER	1	
10	0650140031	SPARK PLUG	1	REPLACES 0650149730 B6HS
11	5801501800	GASKET CYLINDER	1	
12	0011406450	BOLT ASSY	4	
13	0021706000	NUT	4	REPLACES 0021806000
14	0031006000	WASHER	6	
15	030206150	SPRING WASHER	4	REPLACES 0032006000
16	0149069981	ADJUSTING SCREW	1	REPLACES 0149060040
17	020106050	NUT	2	REPLACES 0022706000
18	0241029990	GROMMET	1	

ROBIN EC-08GH ENGINE — GOVERNOR ASSY.

GOVERNOR ASSY.

<u>NO.</u>	<u>PART NO.</u>	<u>PART NAME</u>	<u>QTY.</u>	<u>REMARKS</u>
1	5804005000	GOVERNOR LEVER CP	1	
2	5804500800	CONTROL LEVER	1	
3	5804500900	BUSH	2	
4	5806255008	BUSH NYLON	2	REPLACES 5806083060
5	5804500600	STOP PLATE	1	
6	0230060090	SPACER	1	
7	0105050616	BOLT	1	REPLACES 6202500400
8	1294210113	GOVERNOR YOKE	1	
9	1294220103	GOVERNOR SHAFT	1	
10	1054270111	GOVERNOR ROD	1	
11	1064280113	ROD SPRING	1	REPLACES 1064280111
12	1294250111	GOVERNOR SPRING	1	
13	0170069960	U NUT	1	
14	1294500103	CLIP	1	
15	0200070010	WASHER	1	
16	0217060020	FRICTION WASHER	1	
17	0021706000	NUT	2	
18	0140039980	SCREW AY	2	
19	030206150	SPRING WASHER	1	
20	0016506400	BOLT	1	

ROBIN EC-08GH ENGINE — MUFFLER ASSY.

MUFFLER ASSY.

<u>NO.</u>	<u>PART NO.</u>	<u>PART NAME</u>	<u>QTY.</u>	<u>REMARKS</u>
1	5803032000	MUFFLER	1	
2	5803033000	MUFFLER BRACKET A	1	
3	5803034000	MUFFLER BRACKET B	1	
4	0016706200	BOLT (CYLINDER)	2	
5	0016706160	BOLT (MUFFLER)	4	
6	0031006000	WASHER	6	
7	030206150	SPRING WASHER	8	REPLACES 003200600
8	0031206000	WASHER	2	
9	5805012000	CYLINDER COVER	1	
10	1507520103	CLAMP	1	
11	5809011000	PROTECTOR COMPL.	1	
12	0011308180	BOLT AND WASHER ASSY	3	
13	1293500403	GASKET (MUFFLER)	1	
14	0170069960	U NUT	2	

ROBIN EC-08GH ENGINE — CARBURETOR AND AIR CLEANER ASSY.

CARBURETOR AND AIR CLEANER ASSY.

MT-60H

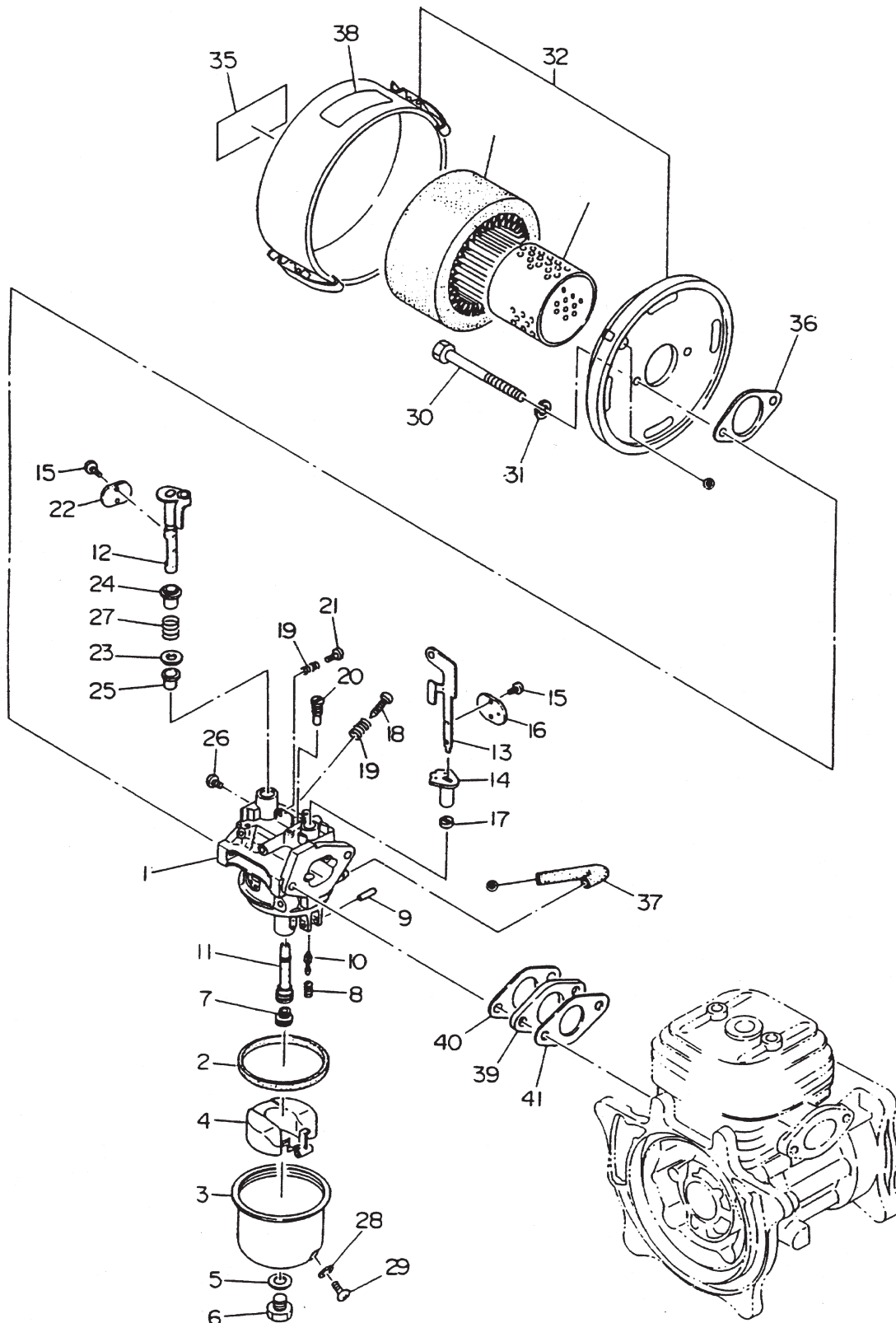

ROBIN EC-08GH ENGINE — CARBURETOR AND AIR CLEANER ASSY.

CARBURETOR AND AIR CLEANER ASSY.

<u>NO.</u>	<u>PART NO.</u>	<u>PART NAME</u>	<u>QTY.</u>	<u>REMARKS</u>
1	5806083003	CARBURETOR ASSY	1	INCLS ITEMS W/* REPLACES 5806083000
2*#	5806083340	PACKING	1	
3*	5806083010	FLOAT BODY ASSY	1	
4*	5806083350	FLOAT	1	
5*	5806083330	PACKING	1	
6*	5806083020	BOLT	1	
7*	1066240008	MAIN JET	1	REPLACES 5806083220
8*	5806083240	SPRING	1	
9*#	5416002050	PIN	1	
10*#	5806083250	NEEDLE	1	
11*	5806083260	MAIN NOZZLE	1	
12*	5806083030	THROTTLE SHAFT ASSY	1	
13*	5806083040	CHOKE LEVER	1	
14*	5806083050	RING	1	
15*	2346245008	SCREW	4	REPLACES 5806083160
16*	5806083310	CHOKE VALVE	1	
17*	5806255008	BUSH, NYLON.....	1	REPLACES 5806083060
18*#	2136239008	PILOT SCREW	1	REPLACES 5416002150
19*#	2096244508	SPRING	2	REPLACES 8046001230
20*#	2076242008	PILOT JET	1	REPLACES 5606003020
21*#	5416002230	SCREW	1	
22*	1616253508	THROTTLE VALVE	1	REPLACES 5806083110
23*	5806083230	PACKING	1	
24*	5806083120	RING	1	
25*#	5806083210	SEAL	1	
26*	5806083130	SCREW	1	
27*#	5806083140	SPRING	1	
28*#	2366254108	PACKING	1	REPLACES 5806083320
29*	5806083150	SCREW	1	
30	0011306750	BOLT	2	
31	030206150	SPRING WASHER	2	
32	5803035002	AIR CLEANER ASSY	1	INCLS. ITEMS W/+ REPLACES 5803035001
33+	5803039000	ELEMENT	1	REPLACES 5803035050
35	5803019020	LABEL , CLEANER	1	
36	5803035030	PACKING	1	
37	0851009980	RUBBER PIPE	1	
38	0736369980	LABEL	1	
39	5803501200	INSULATOR	1	
40	2363590303	GASKET 2 (INSULATOR)	1	
41	1063500103	GASKET (INSULATOR)	1	
#	5806230207	CARBURETOR KIT	1	INCLUDES ITEMS W/#

ROBIN EC-08GH ENGINE — CARBURETOR AND AIR CLEANER ASSY.

CARBURETOR AND AIR CLEANER ASSY.

MT-60H2

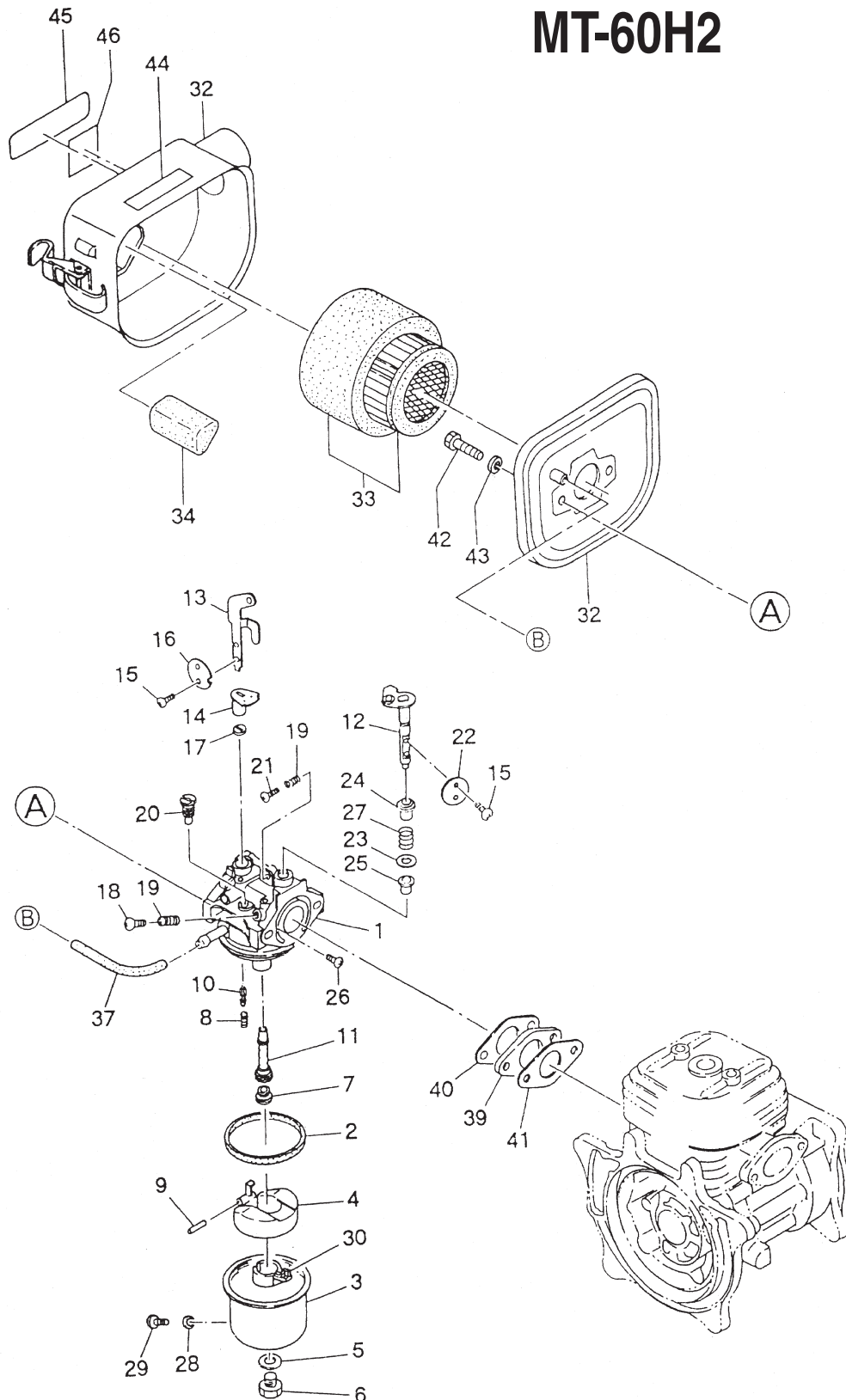

ROBIN EC-08GH ENGINE — CARBURETOR AND AIR CLEANER ASSY.

CARBURETOR AND AIR CLEANER ASSY.

<u>NO.</u>	<u>PART NO.</u>	<u>PART NAME</u>	<u>QTY.</u>	<u>REMARKS</u>
1	5806111000	CARBURETOR ASSY	1	INCLUDES ITEMS W/*
2#*	2366254008	PACKING	1	REPLACES 5806083340
3*	5806083010	FLOAT BODY ASSY	1	
4*	5806083350	FLOAT	1	
5*	5806083330	PACKING	1	
6*	5806083020	BOLT	1	
7*	1296240008	MAIN JET #77.5	1	REPLACES 1296240108
8*	2366244508	SPRING	1	REPLACES 5806083240
9#*	2146251508	PIN	1	REPLACES 5416002050
10#*	5806083400	NEEDLE	1	
11*	5806083260	MAIN NOZZLE	1	
12*	5806083030	THROTTLE SHAFT ASSY	1	
13*	5806803040	CHOKE LEVER	1	
14*	5806083050	RING	1	
15#*	2346245008	SCREW	4	REPLACES 5806083160
16*	5806083310	CHOKE VALVE	1	
17*	2266255008	BUSHING, NYLON	1	REPLACES 5806083060
18*	2136239008	PILOT SCREW	1	REPLACES 5416002150
19#*	2096244508	SPRING	2	REPLACES 8046001230
20#*	2076242008	PILOT JET	1	REPLACES 5606003020
21#*	5416002230	SCREW	1	
22*	1616253508	THROTTLE VALVE	1	REPLACES 5806083110
23*	5806083230	PACKING	1	
24*	5806083120	RING	1	
25#	5806083210	SEAL	1	
26*	5806083130	SCREW	1	
27#	5806083140	SPRING	1	
28#*	2366254108	PACKING	1	REPLACES 5806083320
29*	5806083150	SCREW	1	
30	5806083370	FLOAT STOPPER	1	
32	1063273110	AIR CLEANER ASSY	1	INCLUDES ITEMS W/+
33+	1573620101	ELEMENT SET	1	
34+	1613261008	ELEMENT	1	
37	0851009981	RUBBER PIPE	1	
39	5803501200	INSULATOR	1	
40	2363590303	GASKET 2 (INSULATOR)	1	
41	1063500103	GASKET (INSULATOR)	1	
42	0011306750	BOLT	2	
43	030206150	SPRING WASHER	2	REPLACES 0032006000
44	0732001930	LABEL (CHOKE)	1	
45	1073273308	LABEL, ELEMENT MAINTENANCE	1	
46	920203980	DECAL, ELEMENT SET	1	
	KITCARB60H2	CARBURETOR KIT	1	INCLUDES ALL ITEMS W/#

ROBIN EC-08GH ENGINE — RECOIL STARTER AND BLOWER ASSY.

RECOIL STARTER AND BLOWER ASSY.

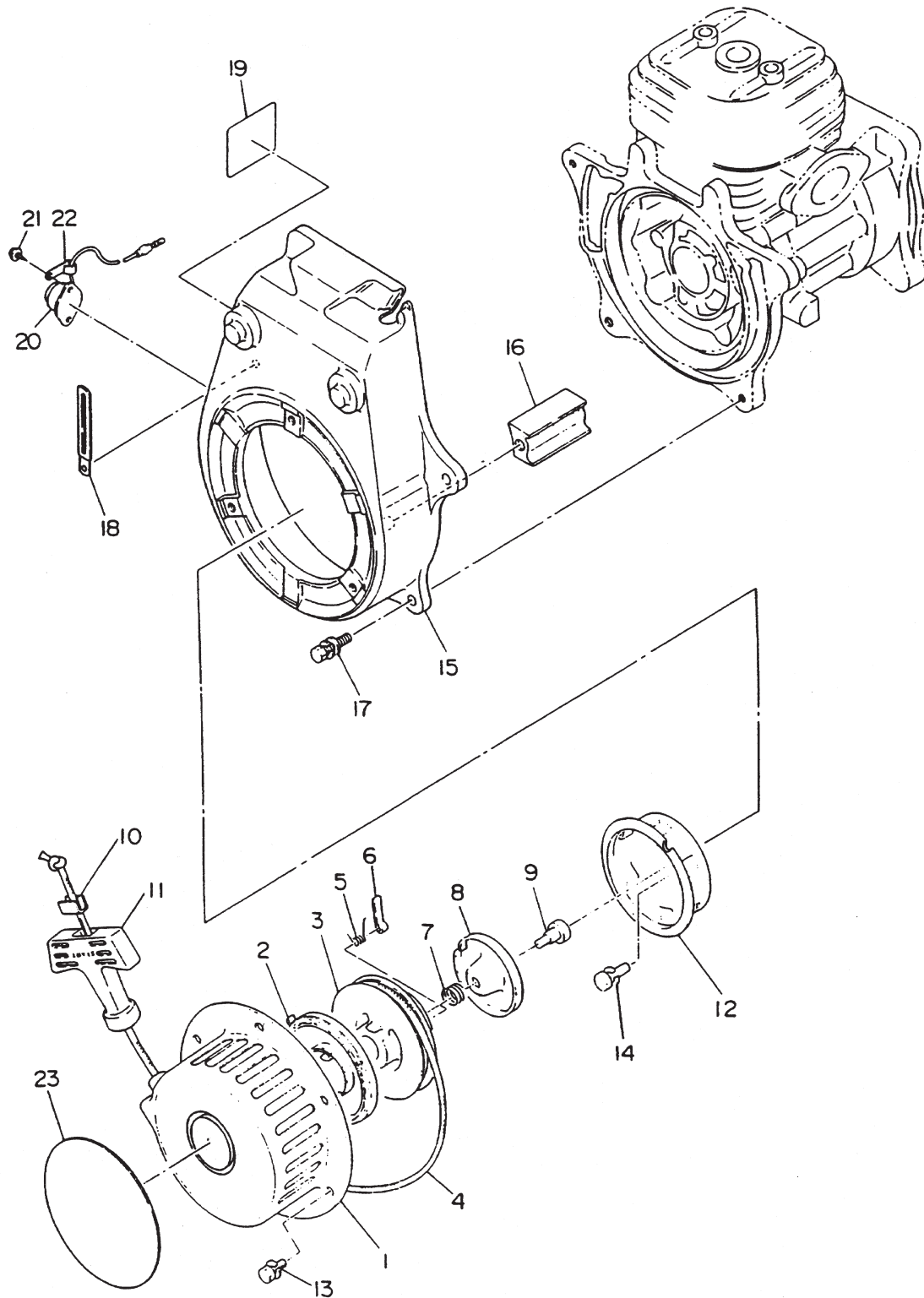

ROBIN EC-08GH ENGINE — RECOIL STARTER AND BLOWER ASSY.

RECOIL STARTER AND BLOWER ASSY.

<u>NO.</u>	<u>PART NO.</u>	<u>PART NAME</u>	<u>QTY.</u>	<u>REMARKS</u>
1	5805001000	RECOIL STARTER CP	1	INCLUDES ITEMS W/*
2*	5805004020	SPIRAL SPRING	1	
3*	5805004030	REEL	1	
4*	5805001020	STARTER ROPE	1	
5*	5805004050	RETURN SPRING	1	
6*	5805004040	RATCHET	1	
7*	5806011030	FRICTION SPRING	1	
8*	EC08A05038	FRICTION PLATE	1	REPLACES 5805004120
9*	5805011020	CENTER SCREW	1	
10*	5515005160	ROPE STOPPER	1	
11*	5805001030	STARTER HANDLE	1	
12*	EC08A050311	STARTER PULLEY	1	REPLACES 5805004140
13	0011006100	BOLT AND WASHER ASSY	3	
14	0011006140	BOLT ASSY	2	
15	5805500100	BLOWER HOUSING	1	
16	5515500200	GUIDE RUBBER	1	
17	0011106200	BOLT ASSY	4	
18	0566000250	CLAMP	1	
19	5809501000	LABEL ENGINE NAME	1	
20	0669900217	STOP BUTTON ASSY	1	REPLACES 0662009870
21	0043504060	SCREW	2	
22	0566030010	CLAMP	1	
23		DECAL	1	NOT SERVICED SEPERATELY

ROBIN EC-08GH ENGINE — MAGNETO ASSY.

MAGNETO ASSY.

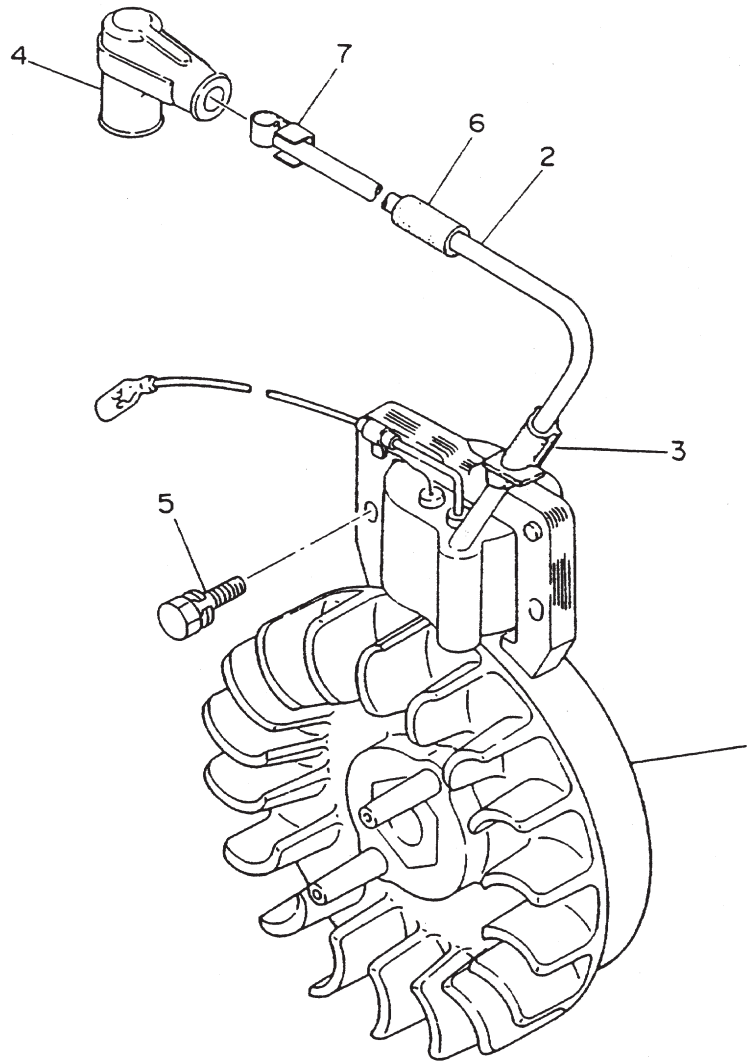

ROBIN EC-08GH ENGINE — MAGNETO ASSY.

MAGNETO ASSY.

<u>NO.</u>	<u>PART NO.</u>	<u>PART NAME</u>	<u>QTY.</u>	<u>REMARKS</u>
1	5807005001	MAGNETO CP	1	INCLUDES ITEM W/*
2*	5807007020	IGNITION COIL	1	REPLACES 5807002020
3	0241069980	GROMMET	1	
4	0655000140	SPARK PLUG CAP	1	
5	0011105250	BOLT AND WASHER ASSY	2	
6	0851029960	VINYL PIPE	1	
7	0659000010	SPARK PLUG TERMINAL	1	REPLACES 0655000100

PAYMENT TERMS

Terms of payment for parts are net 30 days.

FREIGHT POLICY

All parts orders will be shipped collect or prepaid with the charges added to the invoice. All shipments are F.O.B. point of origin. Multiquip's responsibility ceases when a signed manifest has been obtained from the carrier, and any claim for shortage or damage must be settled between the consignee and the carrier.

MINIMUM ORDER

The minimum charge for orders from Multiquip is \$15.00 net. Customers will be asked for instructions regarding handling of orders not meeting this requirement.

RETURNED GOODS POLICY

Return shipments will be accepted and credit will be allowed, subject to the following provisions:

1. A Returned Material Authorization must be approved by Multiquip prior to shipment.
2. To obtain a Return Material Authorization, a list must be provided to Multiquip Parts Sales that defines item numbers, quantities, and descriptions of the items to be returned.
 - a. The parts numbers and descriptions must match the current parts price list.
 - b. The list must be typed or computer generated.
 - c. The list must state the reason(s) for the return.
 - d. The list must reference the sales order(s) or invoice(s) under which the items were originally purchased.
 - e. The list must include the name and phone number of the person requesting the RMA.
3. A copy of the Return Material Authorization must accompany the return shipment.
4. Freight is at the sender's expense. All parts must be returned freight prepaid to Multiquip's designated receiving point.

5. Parts must be in new and resalable condition, in the original Multiquip package (if any), and with Multiquip part numbers clearly marked.
6. The following items are not returnable:
 - a. Obsolete parts. (If an item is in the price book and shows as being replaced by another item, it is obsolete.)
 - b. Any parts with a limited shelf life (such as gaskets, seals, "O" rings, and other rubber parts) that were purchased more than six months prior to the return date.
 - c. Any line item with an extended dealer net price of less than \$5.00.
 - d. Special order items.
 - e. Electrical components.
 - f. Paint, chemicals, and lubricants.
 - g. Decals and paper products.
 - h. Items purchased in kits.
7. The sender will be notified of any material received that is not acceptable.
8. Such material will be held for five working days from notification, pending instructions. If a reply is not received within five days, the material will be returned to the sender at his expense.
9. Credit on returned parts will be issued at dealer net price at time of the original purchase, less a 15% restocking charge.
10. In cases where an item is accepted, for which the original purchase document can not be determined, the price will be based on the list price that was effective twelve months prior to the RMA date.
11. Credit issued will be applied to future purchases only.

PRICING AND REBATES

Prices are subject to change without prior notice. Price changes are effective on a specific date and all orders received on or after that date will be billed at the revised price. Rebates for price declines and added charges for price increases will not be made for stock on hand at the time of any price change.

Multiquip reserves the right to quote and sell direct to Government agencies, and to Original Equipment Manufacturer accounts who use our products as integral parts of their own products.

SPECIAL EXPEDITING SERVICE

A \$35.00 surcharge will be added to the invoice for special handling including bus shipments, insured parcel post or in cases where Multiquip must personally deliver the parts to the carrier.

LIMITATIONS OF SELLER'S LIABILITY

Multiquip shall not be liable hereunder for damages in excess of the purchase price of the item with respect to which damages are claimed, and in no event shall Multiquip be liable for loss of profit or good will or for any other special, consequential or incidental damages.

LIMITATION OF WARRANTIES

No warranties, express or implied, are made in connection with the sale of parts or trade accessories nor as to any engine not manufactured by Multiquip. Such warranties made in connection with the sale of new, complete units are made exclusively by a statement of warranty packaged with such units, and Multiquip neither assumes nor authorizes any person to assume for it any other obligation or liability whatever in connection with the sale of its products. Apart from such written statement of warranty, there are no warranties, express, implied or statutory, which extend beyond the description of the products on the face hereof.

OPERATION AND PARTS MANUAL

HERE'S HOW TO GET HELP

PLEASE HAVE THE MODEL AND SERIAL
NUMBER *ON-HAND* WHEN CALLING

UNITED STATES

Multiquip Corporate Office

18910 Wilmington Ave. Tel. (800) 421-1244
Carson, CA 90746 Fax (800) 537-3927
Contact: mq@multiquip.com

Mayco Parts

800-306-2926 Fax: 800-672-7877
310-537-3700 Fax: 310-637-3284

Service Department

800-421-1244 Fax: 310-537-4259
310-537-3700

MQ Parts Department

800-427-1244 Fax: 800-672-7877
310-537-3700 Fax: 310-637-3284

Warranty Department

800-421-1244, Ext. 279 Fax: 310-537-1173
310-537-3700, Ext. 279

Technical Assistance

800-478-1244 Fax: 310-631-5032

MEXICO

MQ Cipsa

Carr. Fed. Mexico-Puebla KM 126.5 Tel: (52) 222-225-9900
Momoxpan, Cholula, Puebla 72760 Mexico Fax: (52) 222-285-0420
Contact: pmastretta@cipsa.com.mx

CANADA

Multiquip

4110 Industriel Boul. Tel: (450) 625-2244
Laval, Quebec, Canada H7L 6V3 Fax: (450) 625-8664
Contact: jmartin@multiquip.com

UNITED KINGDOM

Multiquip (UK) Limited Head Office

Hanover Mill, Fitzroy Street, Tel: 0161 339 2223
Ashton-under-Lyne, Fax: 0161 339 3226
Lancashire OL7 0TL
Contact: sales@multiquip.co.uk

BRAZIL

Multiquip

Av. Evandro Lins e Silva, 840 - grupo 505 Tel: 011-55-21-3433-9055
Barra de Tijuca - Rio de Janeiro Fax: 011-55-21-3433-9055
Contact: cnavarro@multiquip.com.br, srentes@multiquip.com.br

© COPYRIGHT 2007, MULTIQUIP INC.

Multiquip Inc, the MQ logo and the Mikasa logo are registered trademarks of Multiquip Inc. and may not be used, reproduced, or altered without written permission. All other trademarks are the property of their respective owners and used with permission.

This manual MUST accompany the equipment at all times. This manual is considered a permanent part of the equipment and should remain with the unit if resold.

The information and specifications included in this publication were in effect at the time of approval for printing. Illustrations are based on the *MQ-Mikasa MT60H/H2 Tamping Rammer*. Illustrations, descriptions, references and technical data contained in this manual are for guidance only and may not be considered as binding. Multiquip Inc. reserves the right to discontinue or change specifications, design or the information published in this publication at any time without notice and without incurring any obligations.

Your Local Dealer is:

