

PARTS AND OPERATION MANUAL



MIX N' GO MINI CONCRETE MIXER STEEL DRUM MODELS MC3SE, MC3H (HONDA)

Revision #0 (09/09/02)



MULTIQUIP INC.

18910 WILMINGTON AVE.
CARSON, CALIFORNIA 90746
310-537-3700
800-421-1244
FAX: 310-537-3927

E-mail: mq@multiquip.com • **www:** www.multiquip.com

Atlanta • Boise • Dallas • Houston • Newark
Montreal, Canada • Manchester, UK
Rio De Janeiro, Brazil • Guadalajara, Mexico

PARTS DEPARTMENT:

800-427-1244
FAX: 800-672-7877

SERVICE DEPARTMENT/TECHNICAL ASSISTANCE:

800-478-1244
FAX: 310-631-5032



WARNING



CALIFORNIA — Proposition 65 Warning

Engine exhaust and some of its constituents, and some dust created by power sanding, sawing, grinding, drilling and other construction activities contains chemicals known to the State of California to cause cancer, birth defects and other reproductive harm. Some examples of these chemicals are:

- Lead from lead-based paints.
- Crystalline silica from bricks.
- Cement and other masonry products.
- Arsenic and chromium from chemically treated lumber.

Your risk from these exposures varies, depending on how often you do this type of work. To reduce your exposure to these chemicals: **ALWAYS** work in a well ventilated area, and work with approved safety equipment, such as dust masks that are specially designed to filter out microscopic particles.

HERE'S HOW TO GET HELP

*PLEASE HAVE THE MODEL AND SERIAL NUMBER
ON-HAND WHEN CALLING*

PARTS DEPARTMENT

800-427-1244 or 310-537-3700

FAX: 800-672-7877 or 310-637-3284

SERVICE DEPARTMENT/TECHNICAL ASSISTANCE

800-478-1244 or 310-537-3700

FAX: 310- 537-4259

WARRANTY DEPARTMENT

888-661-4279, or 310-661-4279

FAX: 310- 537-1173

MAIN

800-421-1244 or 310-537-3700

FAX: 310-537-3927

Here's How To Get Help 3
 Table Of Contents 4
 Parts Ordering Procedures 5

Multiquip Mix N' Go — Mini Concrete Mixer

Safety Message Alert Symbols 6-7
 Rules For Safe Operation 8-10
 Operation and Safety Decals 11-12
 Specifications 13
 Dimensions (Mixer) 14
 Dimensions (Electric Motor) 15
 General Information 16
 Mixer Components 17
 Basic Engine 18
 Assembly Instructions 19-20
 Pre-Inspection (Gasoline Engine) 21
 Initial Start-up (Electric Motor) 22
 Initial Start-up (Gasoline Engine) 23-24
 Maintenance 25-27
 Preparation for Long-Term Storage 28
 Troubleshooting (Engine) 30
 Troubleshooting (Engine/Mixer) 31
 Explanation Of Code In Remarks Column 32
 Suggested Spare Parts 33
 Nameplate and Decals 34-35
 Mixer Assy. 36-37

Honda G100K2QA2 Engine

Air Cleaner Assy. 38-39
 Camshaft Assy. 40-41
 Carburetor Assy. 42-42
 Control Assy. 43-44
 Crankcase Cover Assy. 45-46
 Crankshaft Assy. 47-48
 Cylinder Barrel Assy. 49-50
 Fan Cover Assy. 51-52
 Flywheel Assy. 53-54
 Fuel Tank Assy. 55-56
 Gasket Kit Assy. 57-58
 Ignition Coil Assy. 60-61
 Muffler Assy. 62-63
 Piston Assy. 64-65
 Recoil Starter Assy. 66-67
 Labels Assy. 68-69

 Terms and Conditions of Sale 70

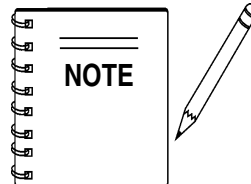

***Specification and part number
 are subject to change without
 notice.***

- Dealer account number
- Dealer name and address
- Shipping address (if different than billing address)
- Return fax number
- Applicable model number
- Quantity, part number and description of each part
- Specify preferred method of shipment:
 - UPS Ground
 - UPS Second Day or Third Day*
 - UPS Next Day*
 - Federal Express Priority One (please provide us with your Federal Express account number)*
 - Airborne Express*
 - Truck or parcel post

**Normally shipped the same day the order is received, if prior to 2PM west coast time.*

Earn Extra Discounts when you order by FAX!

All parts orders which include complete part numbers and are received by fax qualify for the following extra discounts:

<u>Number of line items ordered</u>	<u>Additional Discount</u>
1-9 items	3%
10+ items**	5%

Get special freight allowances when you order 10 or more line items via FAX! **

- UPS Ground Service at no charge for freight
- UPS Third Day Service at one-half of actual freight cost

No other allowances on freight shipped by any other carrier.

**Common nuts, bolts and washers (all items under \$1.00 list price) do not count towards the 10+ line items.

DISCOUNTS ARE SUBJECT TO CHANGE

Fax order discount and UPS special programs revised June 1, 1995

**Extra Fax Discount
for Domestic USA
Dealers Only**

**Up to 5%
extra savings!**

**UPS
Special**
For faxed orders only

**Now! Direct TOLL-FREE access
to our Parts Department!**

Toll-free nationwide:

800-421-1244

Toll-free FAX:

800/6-PARTS-7 • 800-672-7877

MIX N' GO MIXER — SAFETY MESSAGE ALERT SYMBOLS

FOR YOUR SAFETY AND THE SAFETY OF OTHERS!

Safety precautions should be followed at all times when operating this equipment. Failure to read and understand the Safety Messages and Operating Instructions could result in injury to yourself and others.

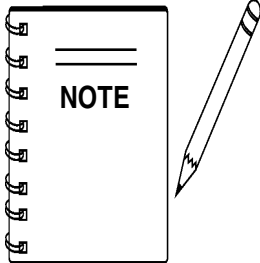

This Owner's Manual has been developed to provide complete instructions for the safe and efficient operation of the Multiquip **MIX N' GO MIXER Models MC3E, MC3B and MC3H**. Refer to the engine manufacturers instructions for data relative to its safe operation.

Before using this mixer, ensure that the operating individual has read and understands all instructions in this manual.

SAFETY MESSAGE ALERT SYMBOLS

The three (3) Safety Messages shown below will inform you about potential hazards that could injure you or others. The Safety Messages specifically address the level of exposure to the operator, and are preceded by one of three words: **DANGER**, **WARNING**, or **CAUTION**.



DANGER: You **WILL** be **KILLED** or **SERIOUSLY** injured if you do not follow directions.



WARNING: You **CAN** be **KILLED** or **SERIOUSLY** injured if you do not follow directions.

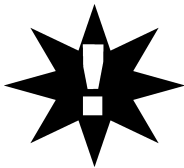

CAUTION: You **CAN** be injured if you do not follow directions.

Potential hazards associated with the MIX N' GO MIXER operation will be referenced with Hazard Symbols which appear throughout this manual, and will be referenced in conjunction with Safety Message Alert Symbols.

HAZARD SYMBOLS



Lethal Exhaust Gases



Engine exhaust gases contain poisonous carbon monoxide. This gas is colorless and odorless, and can cause death if inhaled. **NEVER** operate this equipment in a confined area or enclosed structure that does not provide ample free flow air.



Explosive Fuel

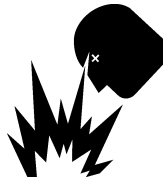

GASOLINE is extremely flammable, and its vapors can cause an explosion if ignited. **DO NOT** start the engine near spilled fuel or combustible fluids. **DO NOT** fill the fuel tank while the engine is running or hot. **DO NOT** overfill tank, since spilled fuel could ignite if it comes into contact with hot engine parts or sparks from the ignition system. Store fuel in approved containers, in well-ventilated areas and away from sparks and flames. **NEVER** use fuel as a cleaning agent.



Burn Hazards



Engine components can generate extreme heat. To prevent burns, **DO NOT** touch these areas while the engine is running or immediately after operations. Never operate the engine with heat shields or heat guards removed.



Rotating Parts



NEVER operate equipment with covers, or guards removed. Keep fingers, hands, hair and clothing away from all moving parts to prevent injury.

MIX N' GO MIXER — SAFETY MESSAGE ALERT SYMBOLS



Accidental Starting



OFF

ALWAYS place the engine or electric motor ON/OFF switch in the **OFF** position when the mixer is not in use.



Respiratory Hazard



ALWAYS wear approved respiratory protection.



Sight and Hearing hazard

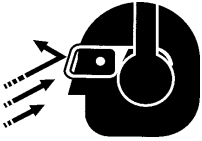

ALWAYS wear approved eye and hearing protection.



Equipment Damage Messages

Other important messages are provided throughout this manual to help prevent damage to your mixer, other property, or the surrounding environment.

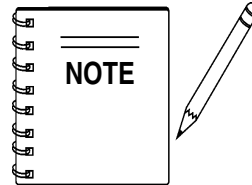

This mixer, other property, or the surrounding environment could be damaged if you do not follow instructions.

RULES FOR SAFE OPERATION

DANGER:



Failure to follow instructions in this manual may lead to serious injury or even death! This equipment is to be operated by trained and qualified personnel only! This equipment is for industrial use only.

The following safety guidelines should always be used when operating the Mix N' Go Mixer:

GENERAL SAFETY

- **DO NOT** operate or service this equipment before reading this entire manual.



- This equipment should not be operated by persons under 18 years of age.

- **NEVER** operate this equipment without proper protective clothing, shatterproof glasses, steel-toed boots and other protective devices required by the job.



- **NEVER** operate this equipment when not feeling well due to fatigue, illness or taking medicine.



- **NEVER** operate this equipment under the influence of drugs or alcohol.



- Whenever necessary, replace nameplate, operation and safety decals when they become difficult read.

- **ALWAYS** check the machine for loosened threads or bolts before starting.

- **ALWAYS** wear proper respiratory (mask) hearing and eye protection equipment when operating the mixer.



- **NEVER** touch the hot exhaust manifold, muffler or cylinder. Allow these parts to cool before servicing engine or mixer.



- **High Temperatures** – Allow the engine to cool before adding fuel or performing service and maintenance functions. Contact with *hot* components can cause serious burns.

- The engine of this mixer requires an adequate free flow of cooling air. **NEVER!** operate the roller mixer in any enclosed or narrow area where free flow of the air is restricted. If the air

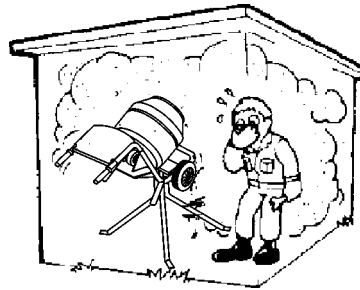

flow is restricted it will cause serious damage to the mixer or engine and may cause injury to people and property. Remember the mixer's engine (gasoline models only) gives off **DEADLY** gases.

- **ALWAYS** refuel in a well-ventilated area, away from sparks and open flames.

- **ALWAYS** use extreme caution when working with **flammable** liquids. When refueling, **stop the engine** and allow it to cool. **DO NOT** smoke around or near the machine. Fire or explosion could result from fuel vapors, or if fuel is spilled on a hot engine.

- **NEVER** operate the mixer in an explosive atmosphere or near combustible materials. An explosion or fire could result causing severe **bodily harm or even death**.

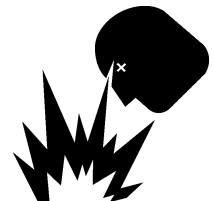

- Topping-off to filler port is dangerous, as it tends to spill fuel.

- Refer to the **Engine Owner's Manual** for engine technical questions or information.

- **NEVER** use accessories or attachments, which are not recommended by Multiquip for this equipment. Damage to the equipment and/or injury to user may result.

- Manufacturer does not assume responsibility for any accident due to equipment modifications.

RULES FOR SAFE OPERATION

- **NEVER** Run engine without air cleaner. Severe engine damage may occur.
- **ALWAYS** read, understand, and follow procedures in Operator's Manual before attempting to operate equipment.
- **ALWAYS** be sure the operator is familiar with proper safety precautions and operations techniques before using roller.
- **ALWAYS** store equipment properly when it is not being used. Equipment should be stored in a clean, dry location out of the reach of children.
- **NEVER** leave the mixer unattended, turn off engine or electric motor when unattended.
- **CAUTION** must always be observed while servicing this mixer. Rotating parts can cause injury if contacted.
- Unauthorized equipment modifications will void all warranties.
- Ensure that any trailing cable is protected against damage and not liable to be tripped over or trapped underneath the mixer.
- Ensure any extension cables must be no longer than 30 meters (100 feet) in length and that the wire section is 2.5 mm².
- **DO NOT** allow extension cord to come into contact with water or fluids.
- **DO NOT** expose power tools to *rain* or *wet* conditions.
- This mixer is intended for the production of concrete, mortar and plaster. Mixer must be used only for its intended purpose.
- This mixer is not suitable for the mixing of *flammable* or *explosive* substances.
- **NEVER** operate the mixer in an *explosive* atmosphere.
- Before starting the mixer, check that all *guards* are in position and correctly fitted.
- **DO NOT** tip mixer onto drum mouth when the motor is running.
- Keep area around the mixer *clear of obstructions* which could cause persons to fall onto *moving parts*.
- **ALWAYS** ensure mixer is on level ground before mixing.
- Become familiar with the controls of the machine before operating.
- **ALWAYS** replace any worn or damaged warning decals.
- Ensure the drum is *rotating* while filling and emptying the drum.
- **DO NOT** use mixer as a wheel barrel.
- **ALWAYS** disconnect AC power plug from power source before moving mixer (electric model only).
- **High Temperatures** – Always stop engine and allow the engine to cool before adding fuel, oil or performing service and maintenance functions. Contact with *hot* components can cause serious burns.
- **NEVER** disconnect any "*emergency or safety devices*". These devices are intended for operator safety. Disconnection of these devices can cause severe injury, bodily harm or even death! Disconnection of any of these devices will void all warranties.
- If mixer is equipped with an electric motor, operate *only* at 120 VAC, 60 Hz.
- Make sure the **OFF/ON** power switch is always in the **OFF** position before inserting the mixer's power plug into an AC receptacle (electric model only).

Maintenance Safety

- **NEVER** lubricate components or attempt service on a running machine.
- **ALWAYS** allow the machine a proper amount of time to cool before servicing.
- Keep the machinery in proper running condition.
- Fix damage to the machine immediately and always replace broken parts, or missing decals.
- Dispose of hazardous waste properly. Examples of potentially hazardous waste are used motor oil, fuel and fuel filters.
- **DO NOT** use food or plastic containers to dispose of hazardous waste.
- **DO NOT** pour waste, oil or fuel directly onto the ground, down a drain or into any water source.

Emergencies

- **ALWAYS** know the location of the nearest *fire extinguisher*.



- **ALWAYS** know the location of the nearest *first aid kit*.



- In emergencies *always* know the location of the nearest phone or **keep a phone on the job site**. Also know the phone numbers of the nearest **ambulance**, **doctor** and **fire department**. This information will be invaluable in the case of an emergency.

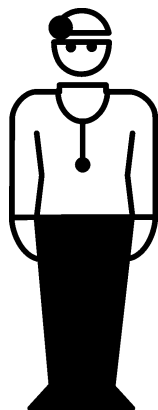
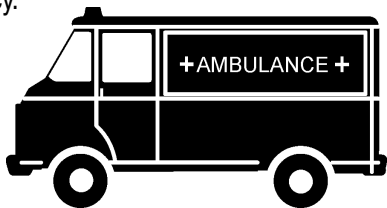

OPERATION AND SAFETY DECALS

Machine Safety Decals

The Mix N' Go mixer is equipped with a number of safety decals. These decals are provided for operator safety and maintenance information. The illustration below and on the next page shows these decals as they appear on the machine. Should any of these decals become unreadable, replacements can be obtained from your dealer.



P/N DCL251



TBD

OPERATION AND SAFETY DECALS

⚠ WARNING!	⚠ ADVERTENCIA!	⚠ AVERTISSEMENT!																																				
<ol style="list-style-type: none"> 1. Read owner's manual before operating mixer. 2. Keep unauthorized and untrained people away from mixer during operation. 3. Make sure all safety devices (guards) are in place before mixer is started. 4. Keep hands and fingers away from moving objects. 5. NEVER leave mixer unattended when operating. 6. ALWAYS check V-belt before starting mixer. 	<ol style="list-style-type: none"> 1. Lea el manual de operación antes de usar la mezcladora. 2. Mantenga personas que no estén autorizadas o capacitadas alejadas de la mezcladora durante el funcionamiento de la máquina. 3. Asegúrese que todos los aparatos de seguridad estén trabajando apropiadamente antes de usar la mezcladora. 4. Mantenga las manos y dedos alejados de objetos en movimiento. 5. NUNCA se aleje de la mezcladora mientras ésta, este trabajando! 6. SIEMPRE inspeccione la banda antes de encender la mezcladora. 	<ol style="list-style-type: none"> 1. Lisez le manuel d' utilisation avant d' utiliser le malaxeur. 2. Seul un personnel qualifié peut être autorisé à se trouver à proximité du malaxeur quand il est en opération. 3. Assurez vous que tous les dispositifs de sécurité sont en place avant de mettre le malaxeur en marche. 4. Gardez les mains et doigts loin de toute pièce en mouvement. 5. NE LAISSEZ jamais le malaxeur sans surveillance quand il est en opération. 6. VEUILLEZ toujours vérifier la courroie avant de mettre le malaxeur en marche. 																																				
<p style="text-align: center;">GASOLINE ENGINE</p> <ul style="list-style-type: none"> • Make sure engine is turned off and spark plug wire is disconnected before cleaning mixer. • DO NOT operate mixer in an enclosed area, proper ventilation is required. • ALWAYS stop the engine and allow engine to cool before adding fuel or oil. • ALWAYS check fuel, oil and air filter before starting engine. 	<p style="text-align: center;">MÁQUINAS DE GASOLINA</p> <ul style="list-style-type: none"> • Asegure que la máquina este apagada y el alambre de la bujía este desconectado antes de empezar a limpiar la mezcladora. • NO encienda la mezcladora en una área cerrada; es necesario estar en una área que tenga apropiada ventilación. • SIEMPRE apague la máquina y permita que se enfrie antes de ponerle gasolina o aceite. • SIEMPRE revise la gasolina, aceite, y el filtro del air antes de encender la máquina. 	<p style="text-align: center;">MOTEUR À ESSENCE</p> <ul style="list-style-type: none"> • Assurez vous que le moteur est arrêté et que le fil de la bougie est débranché avant de nettoyer le malaxeur. • N' UTILISEZ pas le malaxeur dans un endroit fermé, il est nécessaire de travailler dans un endroit avec une bonne aération. • VEUILLEZ toujours vérifiez la courroie avant de mettre le malaxeur en marche. • VÉRIFIEZ toujours le niveau d'essence et d'huile ainsi que le filtre à air avant de mettre le moteur en marche. 																																				
<p style="text-align: center;">ELECTRIC MOTOR</p> <ul style="list-style-type: none"> • Make sure power cord has been disconnected from power source before cleaning mixer. • This electric motor is for 115 VAC operation only. • ALWAYS use an extension cord of proper size, see chart below: <table border="1" style="width: 100%; text-align: center;"> <thead> <tr> <th colspan="4">EXTENSION CORD SIZE</th> </tr> <tr> <th>No. 12 Wire</th> <th>No. 10 Wire</th> <th>No. 8 Wire</th> <th>No. 6 Wire</th> </tr> </thead> <tbody> <tr> <td>50 feet (15.24 meters)</td> <td>75 feet (22.86 meters)</td> <td>100 feet (30.48 meters)</td> <td>200 feet (60.96 meters)</td> </tr> </tbody> </table>	EXTENSION CORD SIZE				No. 12 Wire	No. 10 Wire	No. 8 Wire	No. 6 Wire	50 feet (15.24 meters)	75 feet (22.86 meters)	100 feet (30.48 meters)	200 feet (60.96 meters)	<p style="text-align: center;">MOTOR ELÉCTRICO</p> <ul style="list-style-type: none"> • Asegúrese que el cable de corriente esté de empezar a limpiar la mezcladora. • Este motor eléctrico está solamente capacitado para corriente alterna de 115 voltios. • SIEMPRE use el tamaño de extensiones de alambre indicado como muestra el diagrama abajo: <table border="1" style="width: 100%; text-align: center;"> <thead> <tr> <th colspan="4">TAMAÑO DE EXTENSIÓN</th> </tr> <tr> <th>Alambre Número 12</th> <th>Alambre Número 10</th> <th>Alambre Número 8</th> <th>Alambre Número 6</th> </tr> </thead> <tbody> <tr> <td>50 pies (15.24 metros)</td> <td>75 pies (22.86 metros)</td> <td>100 pies (30.48 metros)</td> <td>200 pies (60.96 metros)</td> </tr> </tbody> </table>	TAMAÑO DE EXTENSIÓN				Alambre Número 12	Alambre Número 10	Alambre Número 8	Alambre Número 6	50 pies (15.24 metros)	75 pies (22.86 metros)	100 pies (30.48 metros)	200 pies (60.96 metros)	<p style="text-align: center;">MOTEUR ÉLECTRIQUE</p> <ul style="list-style-type: none"> • Assurez vous toujours que le cable a été débranché de la prise de courant avant de nettoyer le malaxeur. • Ce moteur électrique à été conçu pour opération à 115 volts seulement. • Il faut toujours utiliser une rallonge de taille appropriée, veuillez s'il vous référer au diagramme suivant: <table border="1" style="width: 100%; text-align: center;"> <thead> <tr> <th colspan="4">TAILLE DE LA RALLONGE</th> </tr> <tr> <th>Cable Numéro 12</th> <th>Cable Numéro 10</th> <th>Cable Numéro 8</th> <th>Cable Numéro 6</th> </tr> </thead> <tbody> <tr> <td>50 pieds (15.24 mètres)</td> <td>50 pieds (15.24 mètres)</td> <td>50 pieds (15.24 mètres)</td> <td>50 pieds (15.24 mètres)</td> </tr> </tbody> </table>	TAILLE DE LA RALLONGE				Cable Numéro 12	Cable Numéro 10	Cable Numéro 8	Cable Numéro 6	50 pieds (15.24 mètres)	50 pieds (15.24 mètres)	50 pieds (15.24 mètres)	50 pieds (15.24 mètres)
EXTENSION CORD SIZE																																						
No. 12 Wire	No. 10 Wire	No. 8 Wire	No. 6 Wire																																			
50 feet (15.24 meters)	75 feet (22.86 meters)	100 feet (30.48 meters)	200 feet (60.96 meters)																																			
TAMAÑO DE EXTENSIÓN																																						
Alambre Número 12	Alambre Número 10	Alambre Número 8	Alambre Número 6																																			
50 pies (15.24 metros)	75 pies (22.86 metros)	100 pies (30.48 metros)	200 pies (60.96 metros)																																			
TAILLE DE LA RALLONGE																																						
Cable Numéro 12	Cable Numéro 10	Cable Numéro 8	Cable Numéro 6																																			
50 pieds (15.24 mètres)	50 pieds (15.24 mètres)	50 pieds (15.24 mètres)	50 pieds (15.24 mètres)																																			
<div style="display: flex; justify-content: space-between;"> <div style="width: 30%;">  <p>ELECTRIC MOTOR MOTOR ELÉCTRICO MOTEUR ÉLECTRIQUE</p> </div> <div style="width: 30%;"> <p>REMOVE BOLT AND FILL WITH EP. 90 GEAR OIL REMOVER EL TORÑILLO Y LLENAR CON ACEITE DE ENGRNAJE EP. 90 ÔTEZ LE BOULON ET REMPLISSEZ AVEC DE L'HUILE EP. 90 À ENGRNAGES</p> <p>CHECK DAILY REVISAR DIARIO VÉRIFIEZ QUOTIDIENNEMENT</p> </div> <div style="width: 30%;">    </div> </div>			<p>NEVER! OPERATE MIXER WITH V-BELT COVER REMOVED. NUNCA! MANEJE LA MEZCLADORA SIN LA COBERTURA DE BANDA-V REMOVIDA. N' UTILISEZ! JAMAIS LE MALAXEUR SANS LE COUVERCLE DE LA COURROIE.</p>																																			

DCL250

P/N DCL250

MIX N' GO MIXER — SPECIFICATIONS

Table 1. Specifications (Engine & Electric Motor)

	Model	HONDA G100K2QA2	BALDOR 17LYE304
Engine/Electric Motor	Type	4-stroke, Side valve, Single Cylinder	3/4 HP, 120 VAC, Single Phase Electric Motor
	Bore X Stroke	20.5 in. X 18.1 in. (52 mm x 46 mm)	N/A
	Displacement	6.0 cu. in. (98 cc)	N/A
	Max Output	2.5 H.P. at 3,600 R.P.M.	3/4 H.P./3,450 RPM
	Standard Idle Speed	1,400 ± 100 R.P.M.	N/A
	Fuel Tank Capacity	Approx. 0.37 U.S. Gallons (1.4 Liters)	N/A
	Fuel	Unleaded Gasoline	N/A
	Lube Oil Capacity	0.48 U.S. Quarts (0.45 Liters)	N/A
	Speed Control Method	Centrifugal Fly-weight Type	N/A
	Starting Method	Recoil Start	N/A
	Dimensions (L x W x H)	10.8 x 10.6 X 13.6 in. (275 X 270 X 345 mm)	11.75 x 6.0 X 8.0 in. (298 X 152 X 203 mm)
Dry Net Weight	19.2 lbs (8.7 Kg.)	Approx. 12 lbs. (5.4 Kg.)	

Table 2. Mix N' Go Mixer Specifications

Height	34 in. (863.6 mm)
Width	23-5/8 in. (584.2 mm)
Length	48-1/2 in. (1,219.2 mm)
Stand Weight	35 lbs. (15.9 Kg)
Maximum Drum Capacity	4.5 cu. ft. (0.13 m ³)
Maximum Mixing Capacity (1/2 bag)	3.0 cu. ft. (0.08 m ³)
Unladen Weight - Electric Motor	129 lbs. (58.5 Kg)
Unladen Weight - Gasoline Engine	138 lbs. (62.6 Kg)

MIX N' GO MIXER — DIMENSIONS (MIXER)

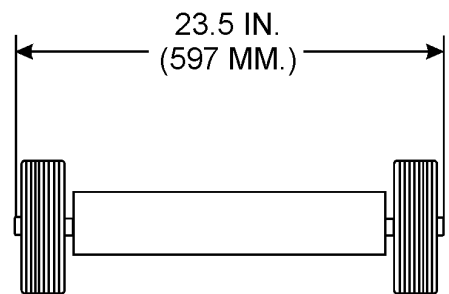
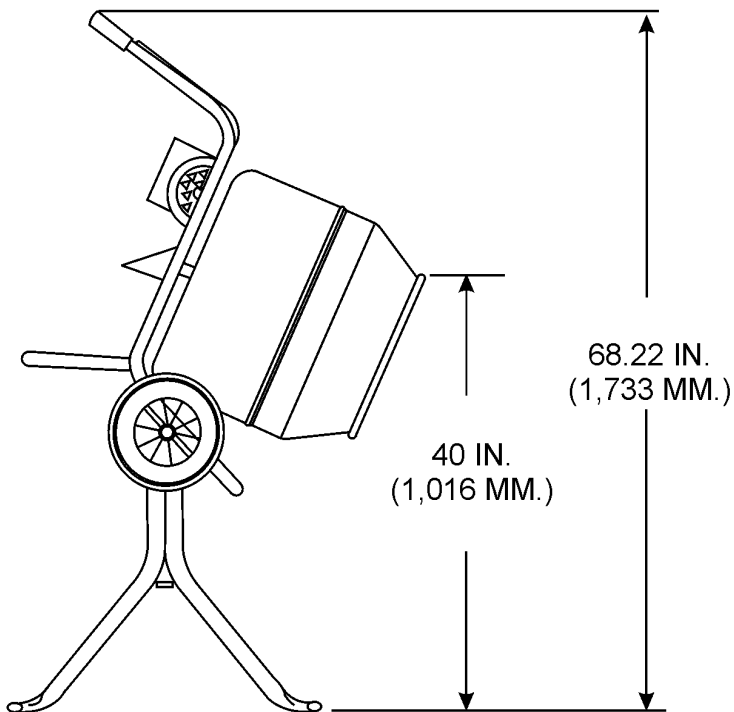
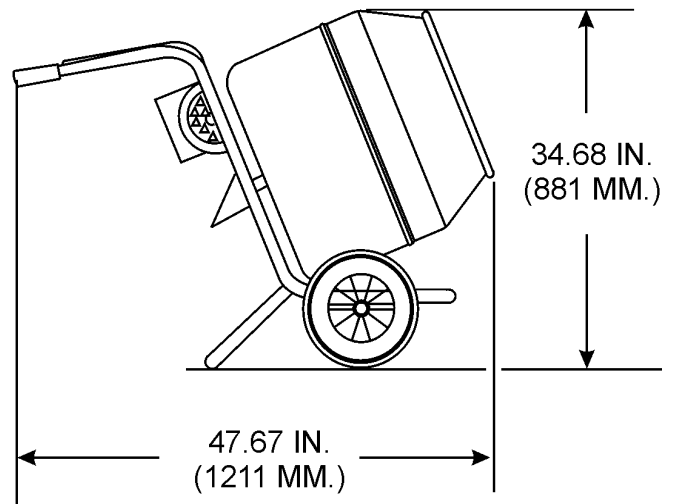
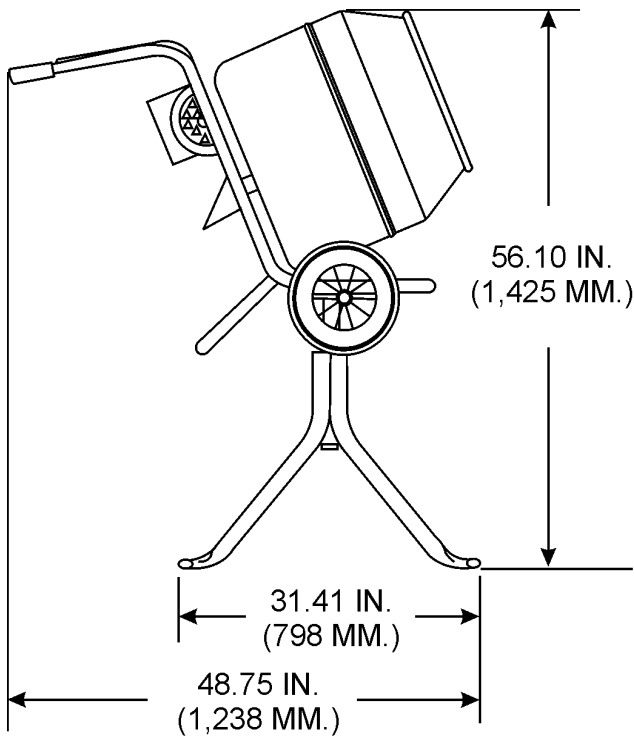

Figure 1. Mix N' Go Mixer Dimensions

MIX N' GO MIXER — DIMENSIONS (ELECTRIC MOTOR)

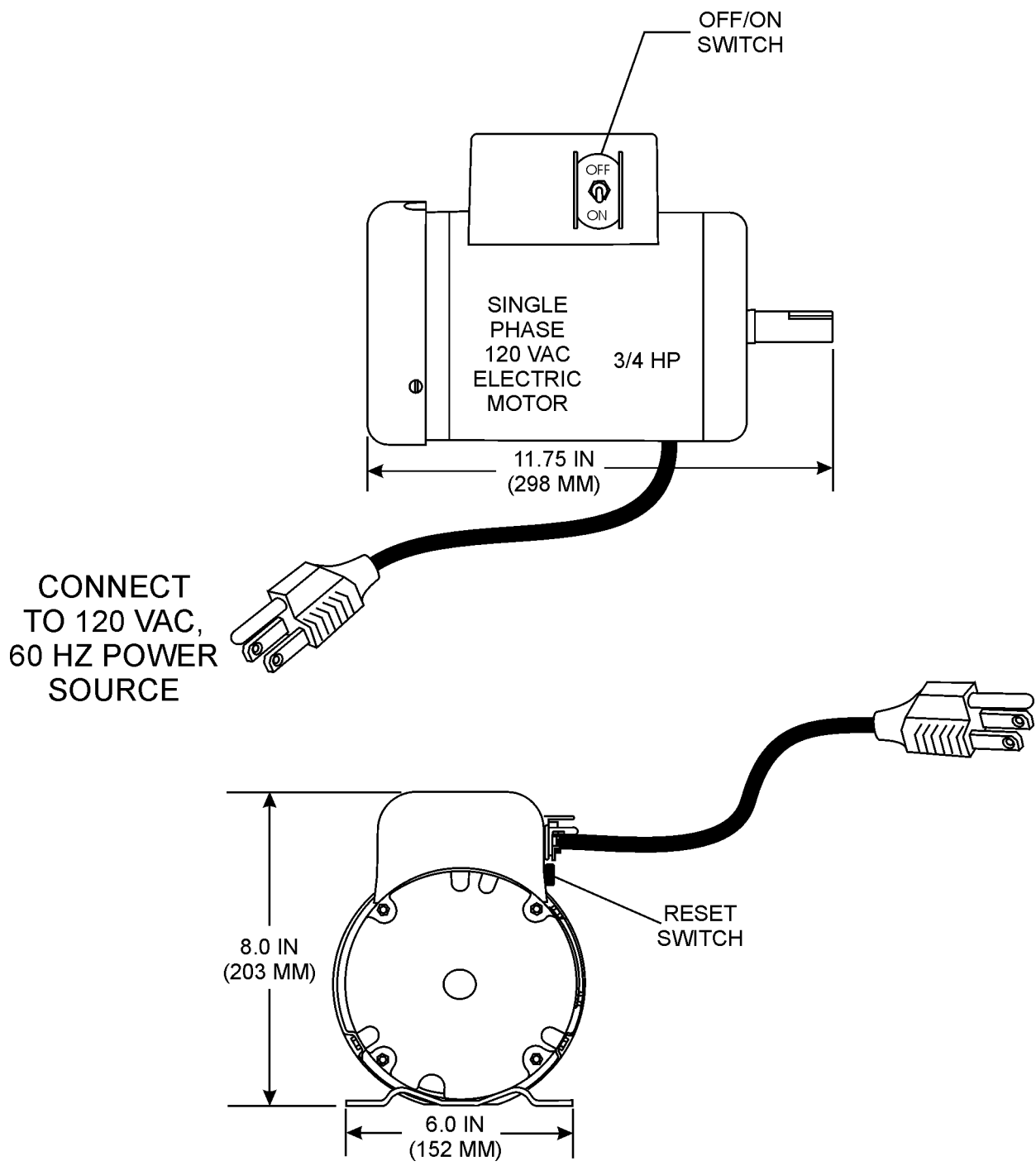

Figure 2. Electric Motor

MIX N' GO MIXER — GENERAL INFORMATION

APPLICATION

This mixer is **only** intended for the production of **concrete**, **mortar** and **plaster**. The mixer must be used for its intended purposes and is not suitable for the mixing of **flammable** or **explosive** substances. The mixer must not be used in an explosive atmosphere.

POWER PLANTS

This portable mixer is powered by either a Honda G100K2, 4-stroke, side valve, single cylinder, gasoline engine rated at 2.5 hp @3,600 rpm. or a 0.75 hp electric motor.

DRUM ASSEMBLY

The drum is instantly removable by unscrewing counter-clockwise. When inserting drum onto gearbox shaft, make sure that drum is fully screwed onto shoulder or threads may be damaged. Use extreme care when screwing on the drum, spinning drum onto the gearbox shaft too fast may damage gearbox.

ELECTRICAL

If mixer is equipped with an **electric motor**, make sure that the power being supplied to the motor corresponds to the voltage rating label on the motor. Supplying the wrong voltage to the electric motor will cause severe electrical damage to the motor.

Always make sure that **OFF/ON** switch on the electric motor is in the **OFF** position before applying power.

It is **strongly recommended** that when plugging in the mixer's power cord into a receptacle, that a G.F.C.I. (**Ground Fault Current Interrupter**) receptacle be used.

EXTENSION CABLES

The extension cable should be a 3-wire configuration that includes a ground wire that conforms to UL code. The wire cross section must be a minimum of 2.5 mm². Choose an extension cord of adequate current carrying as Reference in Table 5. Remember **distance** affects the wire size of the extension cable.

Ensure that the extension cable is carefully laid out avoiding **wet areas**, **sharp edges** and locations where vehicles might run over it. Avoid allowing the extension cable to be trapped underneath the mixer.

Unroll the extension cable fully or it will overheat and could catch fire. Make sure that all extension cable connections are dry and safe. Replace any defective or badly worn extension cable immediately.

PORTABLE GENERATORS

When using a **portable generator** it must have a minimum output of 2.5 kw and be continuous rated.

GEARBOX

The gearbox oil level has been preset at the **factory** prior to shipping. Before inspecting the gearbox oil level (Figures 30 and 31), make sure the gearbox is cold before removing the filler plug. Fill up with **EP90**. or similar gear oil.

TRANSPORTING THE MIXER

Use a ramp (Figure 3) to load and unload the mixer from the transport vehicle. Never drop the mixer onto the ground; damage to the mixer could result.

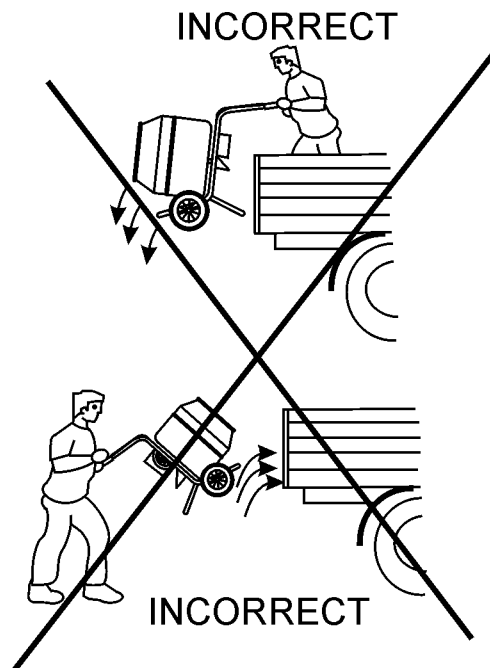
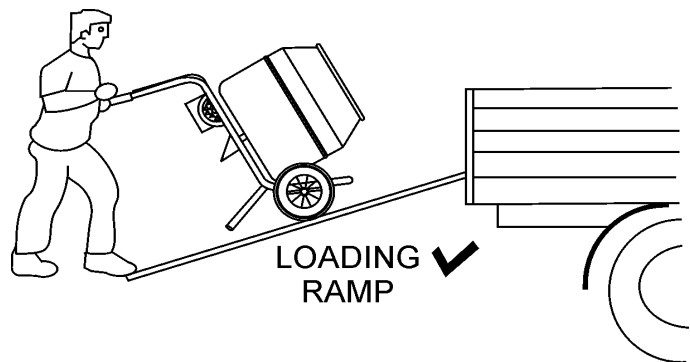

Figure 3. Mixer Loading

MIX N' GO MIXER — MIXER COMPONENTS

Figure 4 shows the basic components of the *Mix N' Go Mixer*.

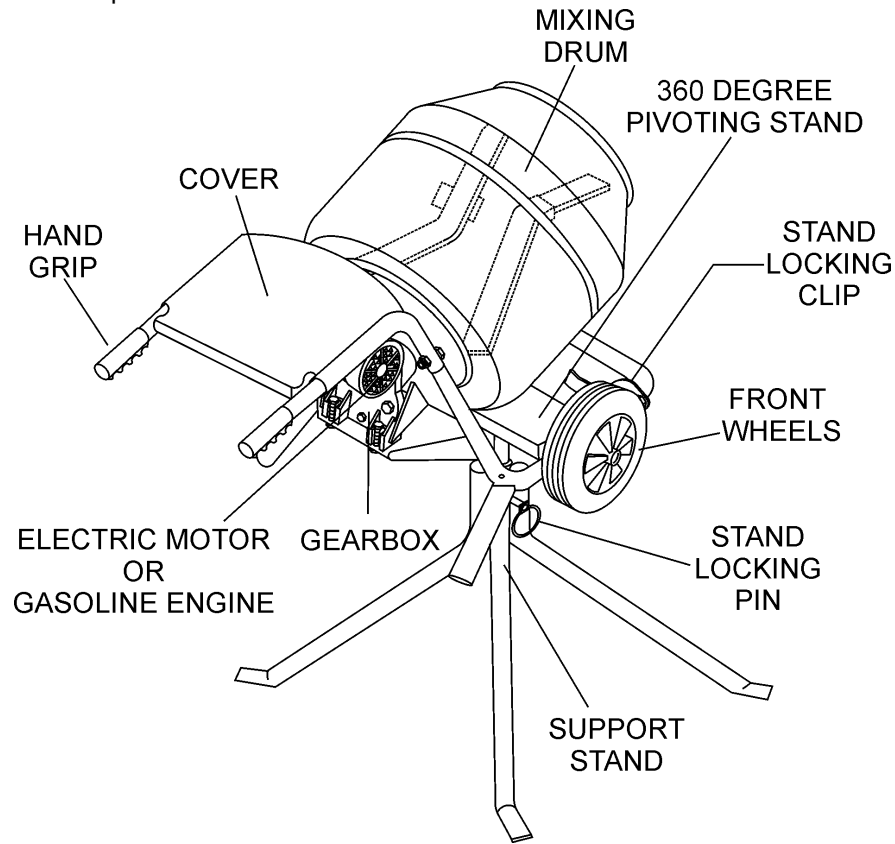

Figure 4. Mixer Components

Table 3. MIXING HINTS

APPLICATIONS	MIX RATIOS	BATCH QUANTITIES					APPROX. BATCH OUTPUT	
		CEMENT 112 lbs. (50 Kgs.) Bag	SAND		STONE			
			CU. FT.	LTR	CU. FT.	LTR	CU. FT.	LTR
Most Ordinary	1:2:4	1/2 BAG	1-1/4	35	2-1/2	71	3	85
Foundations	1:3:6	1/3 BAG	1-1/4	35	2-1/2	71	2-3/4	78
Rough Mass Concrete	1:4:8	1/4 BAG	1-1/4	35	2-1/2	71	2-3/4	78
Watertight Floors, Tanks, Pits, Etc.	1:1-1/2:3	2/3 BAG	1-1/4	35	3	71	3	85

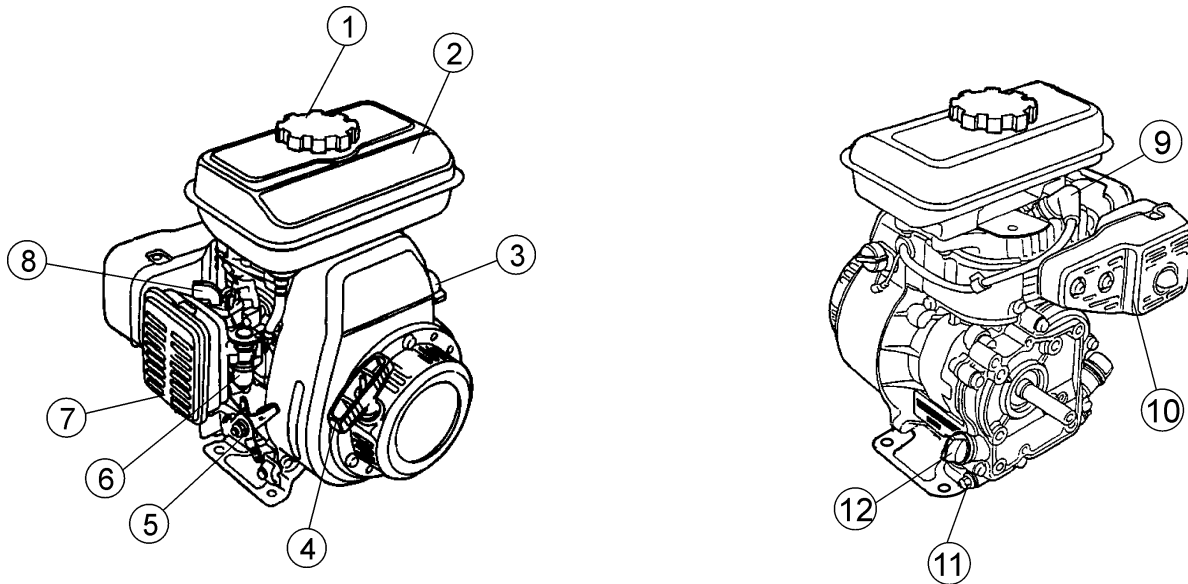

Figure 5. Engine Controls and Components

INITIAL SERVICING

The engine (Figure 5) must be checked for proper lubrication and filled with fuel prior to operation. Refer to the manufacturer's engine manual for instructions and details of operation and servicing. The engine shown above is a **HONDA** engine, operation for other types of engines may vary somewhat.

1. **Fuel Filler Cap** – Remove this cap to add unleaded gasoline to the fuel tank. Make sure cap is tightened securely. **DO NOT** over fill.



! DANGER

Adding fuel to the tank should be done only when the engine is stopped and has had an opportunity to cool down. In the event of a fuel spill, **DO NOT** attempt to start the engine until the fuel residue has been completely wiped up, and the area surrounding the engine is dry.

2. **Fuel Tank** – Holds unleaded gasoline. For additional information refer to engine owner's manual.
3. **Engine ON/OFF Switch** – **ON** position permits engine starting, **OFF** position stops engine operation.
4. **Recoil Starter (pull rope)** – Manual-starting method. Pull the starter grip until resistance is felt, then pull briskly and smoothly.
5. **Throttle Lever** – Used to adjust engine RPM speed (lever advanced forward **SLOW**, lever back toward operator **FAST**).
6. **Fuel Valve Lever** – **OPEN** to let fuel flow, **CLOSE** to stop the flow of fuel.

7. **Air Cleaner** – Prevents dirt and other debris from entering the fuel system. Remove wing-nut on top of air filter canister to gain access to filter element.
8. **Choke Lever** – Used in the starting of a cold engine, or in cold weather conditions. The choke enriches the fuel mixture.

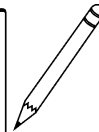
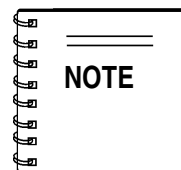

Operating the engine without an air filter, with a damaged air filter, or a filter in need of replacement will allow dirt to enter the engine, causing rapid engine wear.

9. **Spark Plug** – Provides spark to the ignition system. Set spark plug gap to 0.6 - 0.7 mm (0.024 - 0.028 inch) Clean spark plug once a week.
10. **Muffler** – Used to reduce noise and emissions.

! WARNING



Engine components can generate extreme heat. To prevent burns, **DO NOT** touch these areas while the engine is running or immediately after operating. **NEVER** operate the engine with the muffler removed.

11. **Oil Drain Plug** – Remove this plug to remove oil from the engine's crankcase.
12. **Dipstick/Oil Filler Cap** – Remove this cap to determine if the engine oil is low. Add oil through this filler port as recommended in Table 4.

MIX N' GO MIXER — ASSEMBLY INSTRUCTIONS

Assembly

1. Remove the mixer drum and associated components from the packing container (Figure 6). Match the components against the parts list to make sure that they are all accounted for.

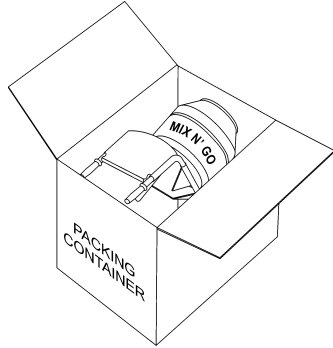

Figure 6. Packing Container

2. Place the mixer frame on a secure level surface, and attach the top cover as shown in Figure 7.

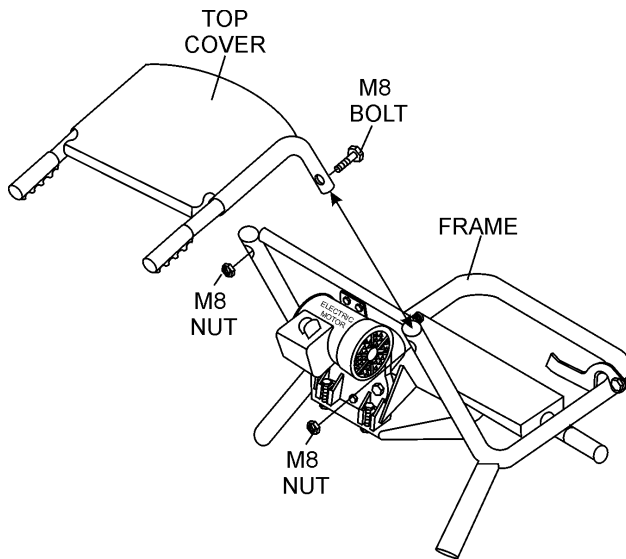

Figure 7. Top Cover Placement

3. Fit the mixing drum onto gearbox shaft as shown in Figure 8. Rotate drum in a clockwise direction, make sure the drum fits right up to the shoulder on the gearbox shaft.

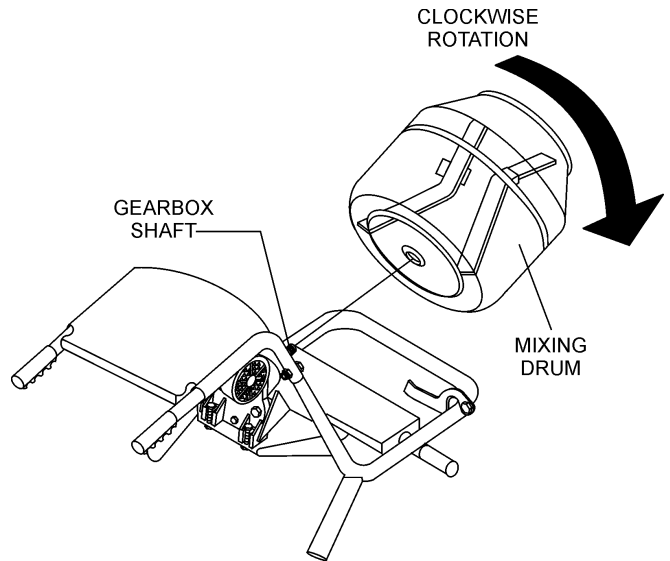

Figure 8. Mixing Drum Placement

4. Place the two halves of the support stand together (Figure 9). The left support stand fits into the center boss on the right support stand.
5. Insert the adapter pin through bosses as shown in Figure 9. Once the adapter pin has been inserted and aligned, insert the locking pin. Place the round part of the locking pin over the bottom section of the adapter pin.

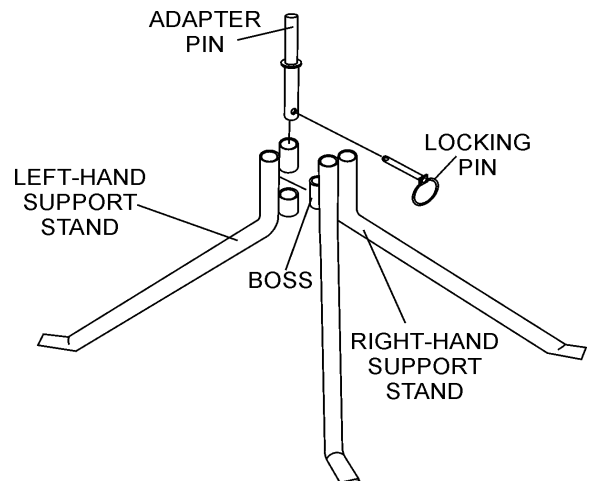
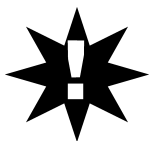

Figure 9. Support Stand

CAUTION



DO NOT *spin* the drum on fast, as this may damage the gearbox.

MIX N' GO MIXER — ASSEMBLY INSTRUCTIONS

6. Tip mixer onto mouth as shown in Figure 10, and insert support stand into frame swivel point.

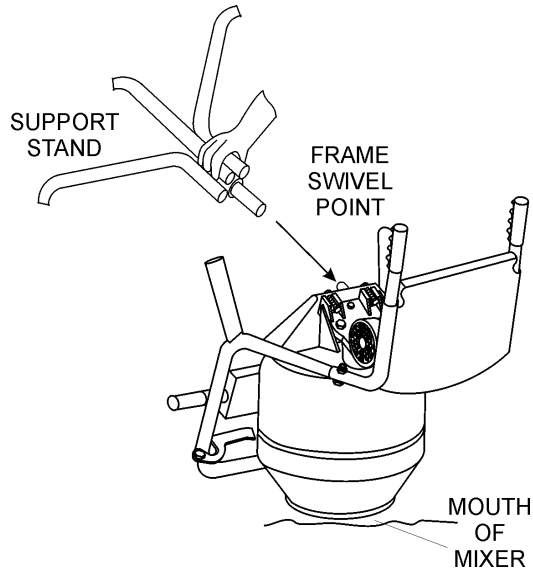

Figure 10. Attaching Support Stand

7. Remove both wheels and wheel retainers from the packing container.
8. Place one wheel on each side of the mixer's axle as shown in Figure 11. Position wheel retainer over axle to secure wheel in place. Use a rubber mallet when striking wheel retainer.

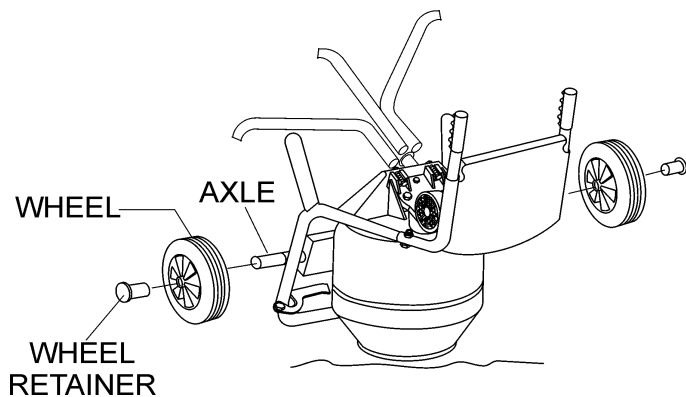

Figure 11. Wheels and Wheel Retainers

9. Before attempting to lift mixer, locate the frame locking clip. Attach the locking clip as shown in Figure 12. This will prevent the mixing drum from moving when the mixer is positioned in an upright position.

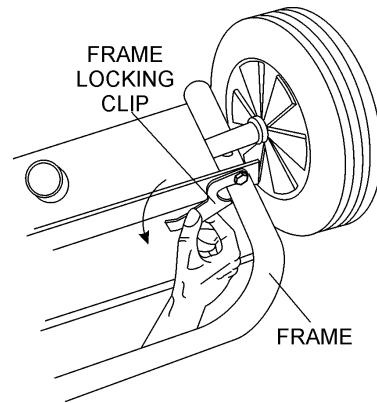

Figure 12. Frame Locking Clip

10. **DO NOT** tilt the mixer on a wet, smooth or slippery surface.



Figure 13. Slippery or Wet Surfaces

11. Once the stand has been assembled, and the locking clip has been secured, begin tilting the mixer to an upright position. Remember **always** tilt from the front of the mixer as shown in Figure 14.

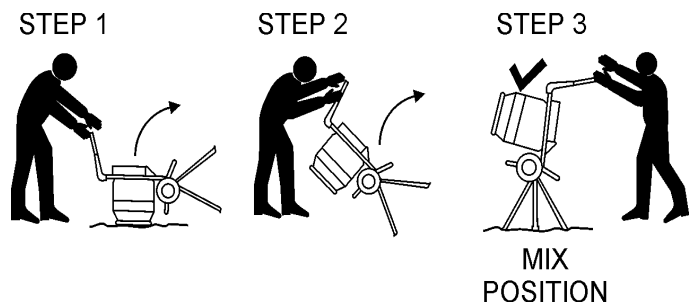
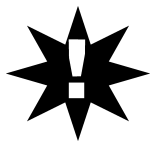

Figure 14. Tilting Mixer to Upright Position

MIX N' GO MIXER — PRE-INSPECTION (GASOLINE ENGINE)

CAUTION



NEVER operate the mixer in a confined area or enclosed area structure that does not provide ample **free flow of air**.



ALWAYS wear approved eye and hearing protection before operating the mixer.

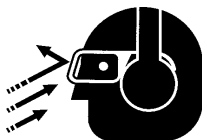

NEVER place hands inside drum while the engine is running. **ALWAYS** shut the engine down before performing any kind of maintenance service on the mixer.



Before Starting

1. Read safety instructions at the beginning of manual.
2. Clean the mixer, removing dirt and dust, particularly the engine cooling air inlet, carburetor and air cleaner.
3. Check the air filter for dirt and dust. If air filter is dirty, replace air filter with a new one as required.
4. Check carburetor for external dirt and dust. Clean with dry compressed air.
5. Check fastening nuts and bolts for tightness.

Engine Oil Check

1. To check the engine oil level, place the mixer on secure level ground with the engine stopped.
2. Remove the filler dipstick from the engine oil filler hole (Figure 15) and wipe clean.

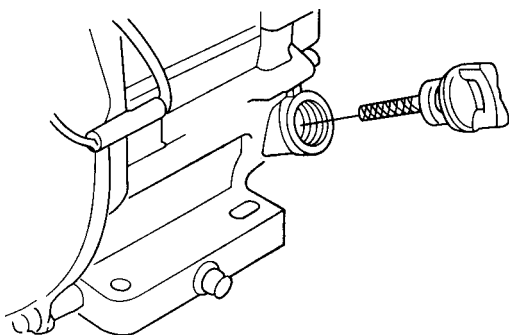

Figure 15. Engine Oil Dipstick (Removal)

3. Insert and remove the dipstick without screwing it into the filler neck. Check the oil level shown on the dipstick.
4. If the oil level is low (Figure 16), fill to the edge of the oil filler hole with the recommended oil type (Table 4). Maximum oil capacity is 0.48 quarts (.45 liters)

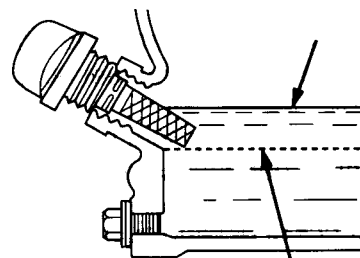

Figure 16. Engine Oil Dipstick (Oil Level)

Table 4. Oil Type

Season	Temperature	Oil Type
Summer	25°C or Higher	SAE 10W-30
Spring/Fall	25°C~10°C	SAE 10W-30/20
Winter	0°C or Lower	SAE 10W-10

Explosive Fuel



Fuel Check

Motor fuels are highly flammable and can be dangerous if mishandled. **DO NOT** smoke while refueling. **DO NOT** attempt to refuel the mixer if the engine is **hot!** or **running**.

1. Remove the gasoline cap located on top of fuel tank.
2. Visually inspect to see if fuel level is low. If fuel is low, replenish with unleaded fuel.
3. When refueling, be sure to use a strainer for filtration. **DO NOT** top-off fuel. Wipe up any spilled fuel.

V-Belt Check

A worn or damaged V-belt can adversely affect the performance of the trowel. If a V-belt is defective or worn simply replace the V-belt as outlined in the maintenance section of this manual.

MIX N' GO MIXER — INITIAL START-UP (ELECTRIC MOTOR)

Initial Start-up Instructions (Electric Motor)

Starting

CAUTION:

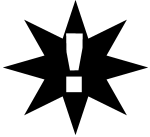

DO NOT attempt to operate the mixer until the Safety, General Information and Inspection sections have been read and understood.

1. Before starting, make sure mixer is positioned on a secure flat surface to prevent tipping.
2. Use an extension cord (see Table 5) of adequate current carrying capacity, insert the electric motor's power plug into one end of the extension cord.
3. **NEVER!** use a *worn* or *frayed* extension cord.
4. **NEVER!** operate mixer with V-belt cover removed.

Table 5. Extension Cord Size

No. 12 Wire	No. 10 Wire	No. 8 Wire	No. 6 Wire
50 (feet) (15.24 meters)	75 (feet) (22.86 meters)	100 (feet) (30.48 meters)	200 (feet) (60.96 meters)

DANGER



NEVER! touch the power cord (Figure 17) with *wet hands* or while *standing in water* when it is connected to a power source. The possibly exists of electrical shock (electrocution) even death. **NEVER!** spray water directly on the electric motor.

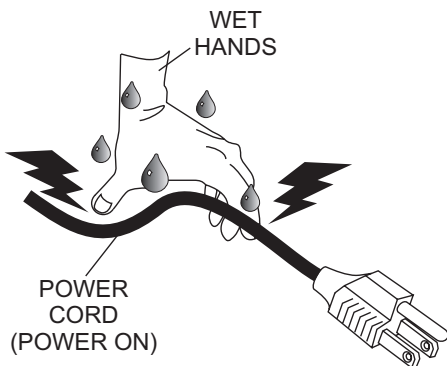

Figure 17. Extension Cord (Wet Hands)

5. Plug the other end of the extension cord into a 120 VAC G.F.C.I. protected receptacle. Remember the power requirements for this electric motor is 120 VAC, 60 Hz. The use of any other input voltage will severely damage the motor.

WARNING:



ALWAYS read the label on the electric motor before applying power. The label will indicate the proper power requirements for the motor. Remember the use of any other input voltage will severely damage the motor.

WARNING:



To prevent tripping (Figure 18) of both the mixer and personnel, position the extension cord so that it lays flat and is not curled underneath the mixer.

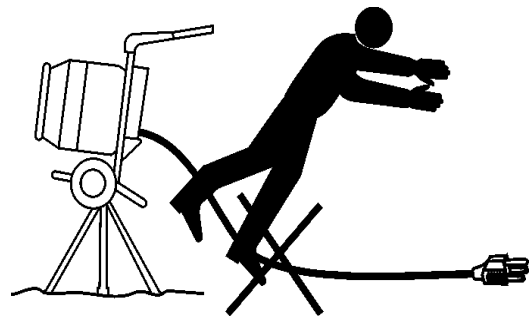

Figure 18. Mixer (Tripping)

6. The drum should be rotating allowing the mixing process to begin. Use a shovel (Figure 19) to place the cement mix inside the drum, add water as required. Be careful to only place the *tip* of the shovel inside the drum. Placing the shovel all the way inside the drum will cause the shovel to strike the blades. This condition will make the shovel rotate, and could cause injury to personnel.

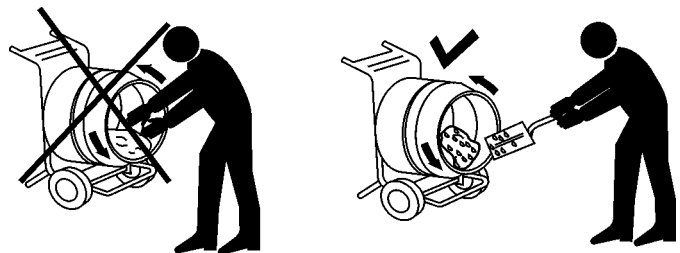

Figure 19. Mixing Drum (Placing cement Mix)

6. See Table 3 for mixing hints. **NEVER!** place hands inside the drum while the drum is rotating.

MIX N' GO MIXER — INITIAL START-UP (GASOLINE ENGINE)



DO NOT attempt to operate the mixer until the Safety, General Information and Inspection sections of this manual have been read and thoroughly understood.

This section is intended to assist the operator with the initial start-up of the walk-behind trowel. It is extremely important that this section be read carefully before attempting to use the trowel in the field.

Starting the Engine (*HONDA* engine)

1. Place the engine ***fuel valve lever*** (Figure 20) to the "**ON**" position.

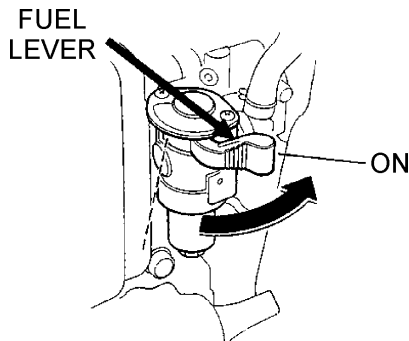

Figure 20. Engine Fuel Valve Lever (ON Position)

2. Place the trowel's ***throttle lever*** (Figure 21) to the "**IDLE**" position.

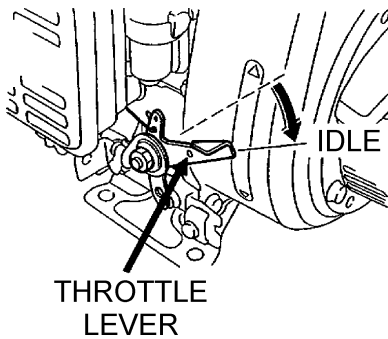

Figure 21. Throttle Lever (Idle Position)

3. Place the ***choke lever*** (Figure 22) in the "**OPEN**" position if starting a ***cold*** engine.

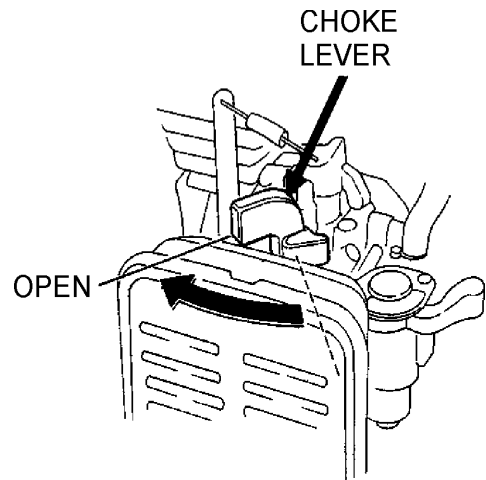

Figure 22. Engine Choke Lever (Open)

4. Place the ***choke lever*** (Figure 23) in the "**CLOSED**" position if starting a ***warm engine*** or the ***temperature is warm***.

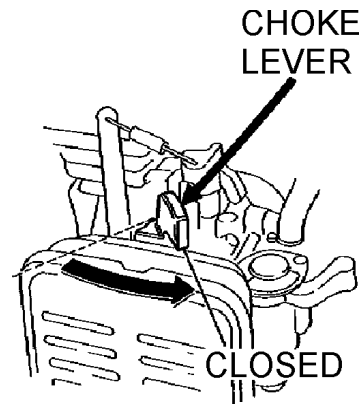

Figure 23. Engine Choke Lever (Closed)

5. Place the ***engine ON/OFF switch*** (Figure 24) in the "**ON**" position.

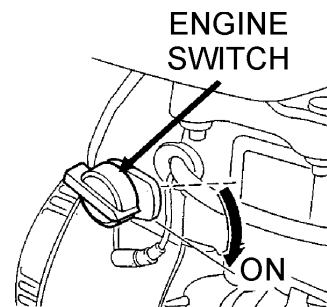

Figure 24. Engine ON/OFF Switch (ON Position)

MIX N' GO MIXER — INITIAL START-UP (GASOLINE ENGINE)

6. Grasp the starter grip (Figure 25) and slowly pull it out. The resistance becomes the hardest at a certain position, corresponding to the compression point. Pull the starter grip briskly and smoothly for starting.

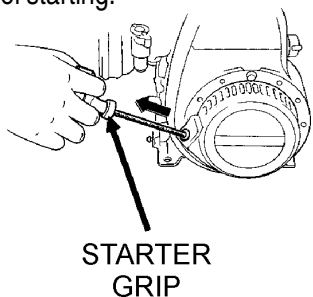

Figure 25. Starter Grip

7. If the engine has started, slowly return the choke lever (Figure 23) to the **CLOSED** position. If the engine has not started repeat steps 1 through 6.
8. Before the mixer is placed into operation, run the engine for several minutes. Check for fuel leaks, and noises that would associate with a loose V-belt cover or component.
9. To begin mixing, place the throttle lever (Figure 26) in the "**RUN**" position

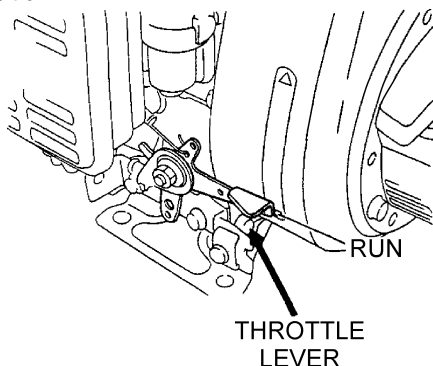

Figure 26. Throttle Lever (Run Position)

Stopping The Engine

Normal Shutdown

1. Move the throttle lever to the **IDLE** position (Figure 27) and run the engine for three minutes at low speed.

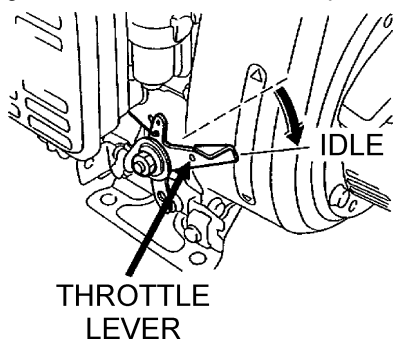

Figure 27. Throttle Lever (Idle Position)

2. After the engine **cools**, turn the engine ON/OFF switch to the "**OFF**" position (Figure 28).

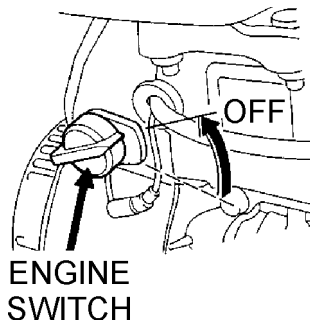

Figure 28. Engine ON/OFF Switch (OFF Position)

3. Close the **fuel shut-off valve** (Figure 29) by moving the fuel valve lever to the **OFF** position.

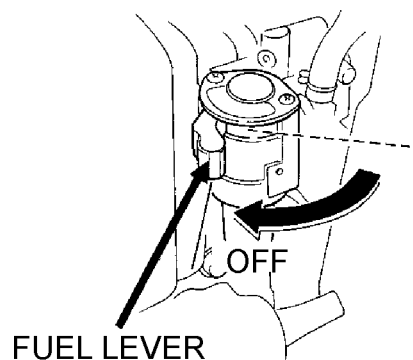

Figure 29. Fuel Valve Lever (OFF Position)

Emergency Showdown

1. Move the throttle lever quickly to the **IDLE** position, and turn the engine ON/OFF switch to the **OFF** position.

Maintenance

Gearbox Oil Check



1. Position the mixer on a level surface and place a **support block** under the front of the mixer frame as shown in Figure 30. This will level the mixer.
2. **NEVER!** check the gearbox oil level with the mixer tilted up or down. **ALWAYS** check the gearbox oil level with the mixer in a level position.

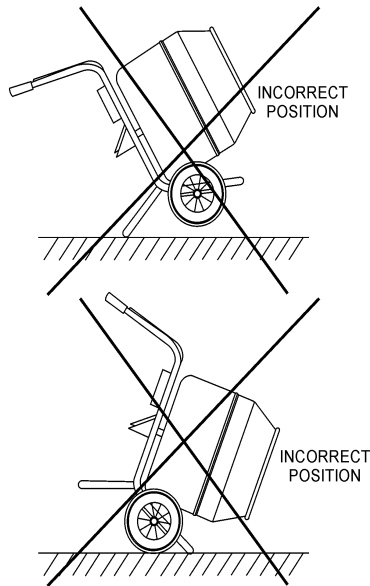
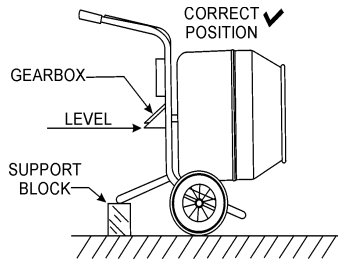
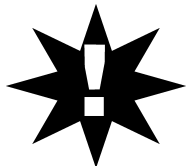

Figure 30. Mixer Positioning (Gearbox Oil Level)

CAUTION :



Check the gearbox oil level **monthly** before operating mixer. Low oil level or no oil will severely damage gearbox.

3. Before inspecting the gearbox oil level, make sure the gearbox is cold before removing the filler plug. Hot! oil can burn skin and cause injury. Let oil **cool** before checking.
4. Remove gearbox oil filler plug (Figure 31) and fill with EP90 or similar gear oil to the level of the filler plug. Replace gearbox oil every 3,000 hours. Gerabox oil capacity is **8-10 ounces**.

5. Insert oil filler plug and tighten.

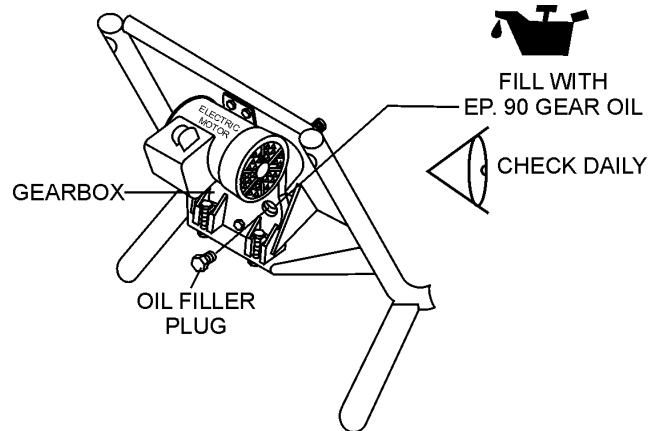
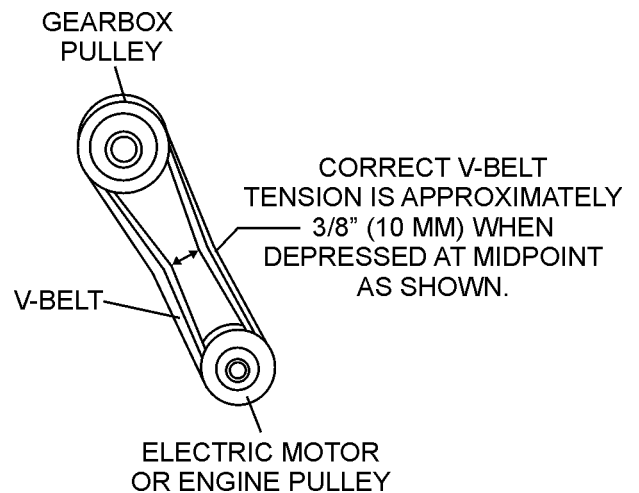

Figure 31. Gearbox Oil Level Check

V-Belt Check

1. To adjust V-belts, remove V-belt cover and loosen the main motor mount bolts, raise electric motor and retighten bolts. Belt tension should be adjusted so that the maximum deflection is approximately 3/8 inch (10 mm).
2. Replace V-belt cover.



Gerarbox Removal

1. Remove drum by turning counter-clockwise to release from gearbox shaft.
2. Remove pulley, remember the nut securing the pulley is left-hand threaded. Remove circlip, and draw out shaft.
3. Remove the 5 bolts securing rear plate.
4. Reassemble in reverse order, taking care to ensure gear teeth are meshed correctly.

MIX N' GO MIXER — MAINTENANCE (GASOLINE ENGINE)

Table 6. Engine Maintenance Schedule

DESCRIPTION (3)	OPERATION	BEFORE	FIRST MONTH OR 10 HRS.	EVERY 3 MONTHS OR 25 HRS.	EVERY 6 MONTHS OR 50 HRS.	EVERY YEAR OR 100 HRS.	EVERY 2 YEARS OR 200 HRS.
Engine Oil	CHECK	X					
	CHANGE		X				
Air Cleaner	CHECK	X					
	CHANGE			X (1)			
All Nuts & Bolts	Re-tighten If Necessary	X					
Spark Plug	CHECK-CLEAN				X		
	REPLACE						X
Cooling Fins	CHECK				X		
Spark Arrester	CLEAN					X	
Fuel Tank	CLEAN					X	
Fuel Filter	CHECK					X	
Idle Speed	CHECK-ADJUST					X (2)	
Valve Clearance	CHECK-ADJUST						X (2)
Fuel lines	CHECK	Every 2 years (replace if necessary) (2)					

(1) Service more frequently when used in **DUSTY** areas.

(2) These items should be serviced by your servic dealer, unless you have the proper tools and are mechanically proficient. Refer to the HONDA shop Manual for service procedures

(3) For commercial use, log hours of operation to determine proper maintenance intervals.

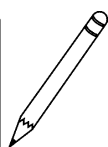
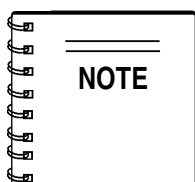

Reference manufacturer engine manual for specific servicing instructions.

MIX N' GO MIXER — MAINTENANCE (GASOLINE ENGINE)

Maintenance

Perform the scheduled maintenance procedures as defined by Table 6 and below:

DAILY

- Thoroughly remove dirt and oil from the engine and control area. Clean or replace the air cleaner elements as necessary. Check and retighten all fasteners as necessary. Check the gearbox for oil leaks. Repair or replace as needed.

WEEKLY

- Remove the fuel filter cap and clean the inside of the fuel tank.
- Remove or clean the filter at the bottom of the tank.
- Remove and clean the spark plug (Figure 32), then adjust the spark gap to 0.024 ~0.028 inch (0.6~0.7 mm). This unit has electronic ignition, which requires no adjustments.

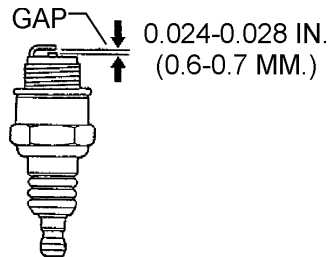

Figure 32. Spark Plug Gap

ENGINE OIL

- Drain the engine oil when the oil is **warm** as shown in Figure 33.
- Remove the oil drain bolt and sealing washer and allow the oil to drain into a suitable container.
- Replace engine oil with recommended type oil as listed in Table 4. Engine oil capacity is .48 quarts (0.45 liters). **DO NOT** overfill.
- Install drain bolt with sealing washer and tighten securely.

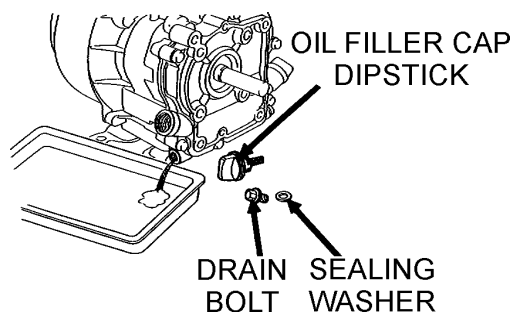
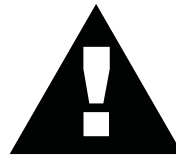

Figure 33. Engine Oil (Draining)

DANGER :



DO NOT use gasoline as a cleaning solvent, because that would create a risk of fire or explosion.

ENGINE AIR CLEANER

- Remove the air cleaner cover and foam filter element as shown in Figure 34.
- Clean foam element in warm, soapy water or nonflammable solvent. Rinse and dry thoroughly. Dip the element in clean engine oil and completely squeeze out the excess oil from the element before installing.

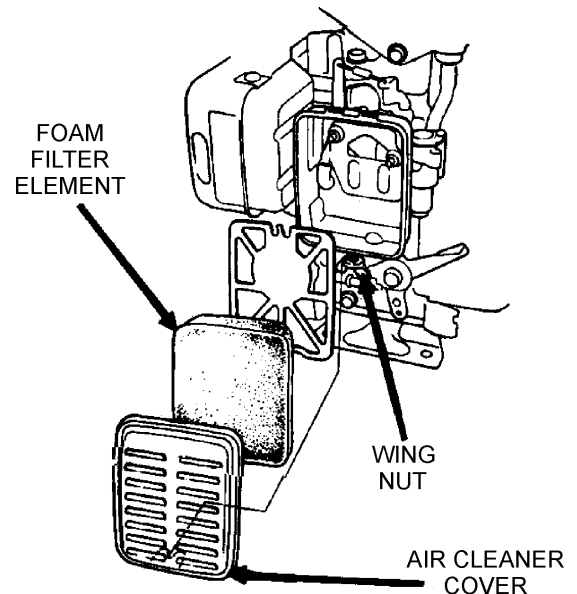

Figure 34. Engine Air Cleaner

MIX N' GO MIXER — PREPARATION FOR LONG -TERM STORAGE

Mixer Storage

For storage of the mixer for over 30 days, the following is recommended:

- Drain the fuel tank completely, or add STA-BIL to the fuel.
- Run the engine until the fuel is completely consumed.
- Completely drain used oil from the engine crankcase and fill with fresh clean oil, then follow the procedures described in the engine manual for engine storage.
- Clean the entire mixer and engine compartment.
- Cover the mixer and place it a clean dry area, that is protected from harsh elements.

MIX N' GO MIXER — TROUBLESHOOTING (ENGINE)

TABLE 7. ENGINE TROUBLESHOOTING

SYMPTOM	POSSIBLE PROBLEM	SOLUTION
Difficult to start		
Fuel is available but spark plug will not ignite. (Power available at high tension cable).	Ignition plug being bridge?	Check ignition system.
	Carbon deposit at ignition?	Clean or replace ignition.
	Short circuit due to defective insulators?	Replace insulators.
	Improper spark gap?	Set spark plug gap to the correct gap.
Fuel is available but spark plug will not ignite. (Power NOT available at high tension cable).	Short circuit at stop switch?	Check stop switch circuit. Replace stop switch if defective.
	Ignition coil defective?	Replace ignition coil.
Fuel is available and spark plug ignites (compression normal).	Muffler clogged with carbon deposits?	Clean or replace muffler.
	Fuel in use inadequate (water, dust)?	Flush fuel sytem and replace with fresh fuel.
	Air Cleaner clogged?	Clean or replace air cleaner.
Fuel is available and spark plug ignites (compression low).	Defective cylinder head gasket?	Tighten cylinder head bolts or replace head gasket.
	Cylinder worn?	Replace cylinder.
	Spark plug loose?	Tighen spark plug.
Operation not satisfactory		
Not enough power available (compression normal, no miss-firing).	Air cleaner clogged?	
	Air in fuel line?	Bleed (remove air) from fuel line.
	Fuel level in carbureator float chamber improper?	Adjust carbureator float
	Carbon deposits in cylinder?	Clean or replace cylinder
Not enough power available (compression normal, miss-firing).	Ignition coil defective?	Flush fuel sytem and replace with fresh fuel.
	Ignition plug often shorts?	Replace ignition wires, clean ignition.
	Fuel in use inadequate (water, dust)?	Flush fuel sytem and replace with fresh fuel.
Engine overheats.	Excessive carbon depostion in combustion chamber?	Clean or replace crankcase.
	Exhaust or muffler clogged with carbon.	Clean or replace muffler.
	Spark plug heat value incorrect?	Replace spark plug with correct type spark plug.

MIX N' GO MIXER — TROUBLESHOOTING (ENGINE/MIXER)

TABLE 7. ENGINE TROUBLESHOOTING (Continued)

SYMPTOM	POSSIBLE PROBLEM	SOLUTION
Operation not satisfactory		
Rotational speed fluctuates.	Governor adjustment improper?	Adjust governor to correct lever.
	Governor spring defective?	Clean or replace ignition.
	Fuel flow erratic?	Check fuel line.
	Air taken in through suction line?	Check suction line.
Recoil starter not working properly.	Dust in rotating part?	Clean recoil starter assembly.
	Spring spring failure?	Replace sprial spring.

TABLE 8. MIXER TROUBLESHOOTING

SYMPTOM	POSSIBLE PROBLEM	SOLUTION
Drum rotates rough.	Defective gearbox?	Check that the gears and bearings are not worn . Replace as necessary.
	Worn V-belt?	Replace V-belt.
	Loose pulley?	Tighten or replace pulley.
Drum does not rotate at all.	Incorrect or no voltage being supplied to electric motor?	Check that the electric motor has the correct supply voltage.
	Power to electric motor?	Inspect power source and extension cord. Push reset button on electric motor.
	Fuel?	Check level of fuel in fuel tank. Add fuel if necessary. Make sure fuel is being supplied to the engine. Check to ensure that the fuel filter is not clogged.
	Broken V-belt?	Replace V-belt.
	Defective gearbox?	Check that the gears and bearings are not broken. Replace as necessary.
	Defective motor?	Replace motor.

MIX N' GO MIXER — EXPLANATION OF CODE IN REMARKS COLUMN

How to read the marks and remarks used in this parts book.

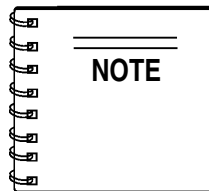

The contents of this parts catalog are subject to change without notice.

Items Found In the “Remarks” Column

Serial Numbers-Where indicated, this indicates a serial number range (inclusive) where a particular part is used.

Model Number-Where indicated, this shows that the corresponding part is utilized only with this specific model number or model number variant.

Items Found In the “Items Number” Column

All parts with same symbol in the number column, *, #, +, %, or ■, belong to the same assembly or kit.

Note: If more than one of the same reference number is listed, the last one listed indicates newest (or latest) part available.

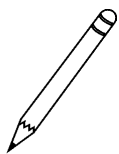
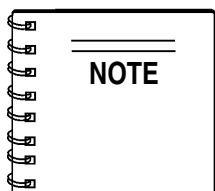

If more than one of the same reference number is listed, the last one listed indicates newest (or latest) part available.

MIX N' GO MIXER — SUGGESTED SPARE PARTS

MIX N' GO MIXER 1 TO 3 UNITS *1 to 3 Units*

Qty.	P/N	Description
2	DM1840	V-BELT, A23 (ELECTRIC MOTOR)

MIX N' GO MIXER 1 TO 3 UNITS WITH HONDA G100K2QA2, *1 to 3 Units*

Qty.	P/N	Description
2	9807354776	SPARK PLUG HONDA
2	17631ZH7003	TANK CAP (HONDA)
3	17211896000	AIR CLEANER ELEMENT (HONDA)
2	17218ZE2505	FILTER OUTER (HONDA)
4	10611	V-BELT (A-21)

MIX N' GO MIXER — NAME PLATE AND DECALS

NAME PLATE AND DECALS

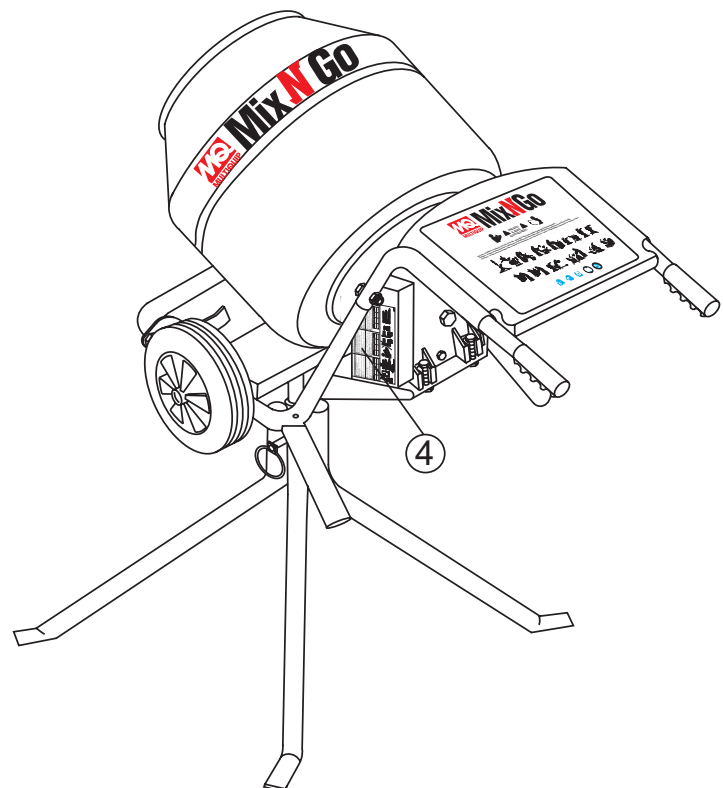
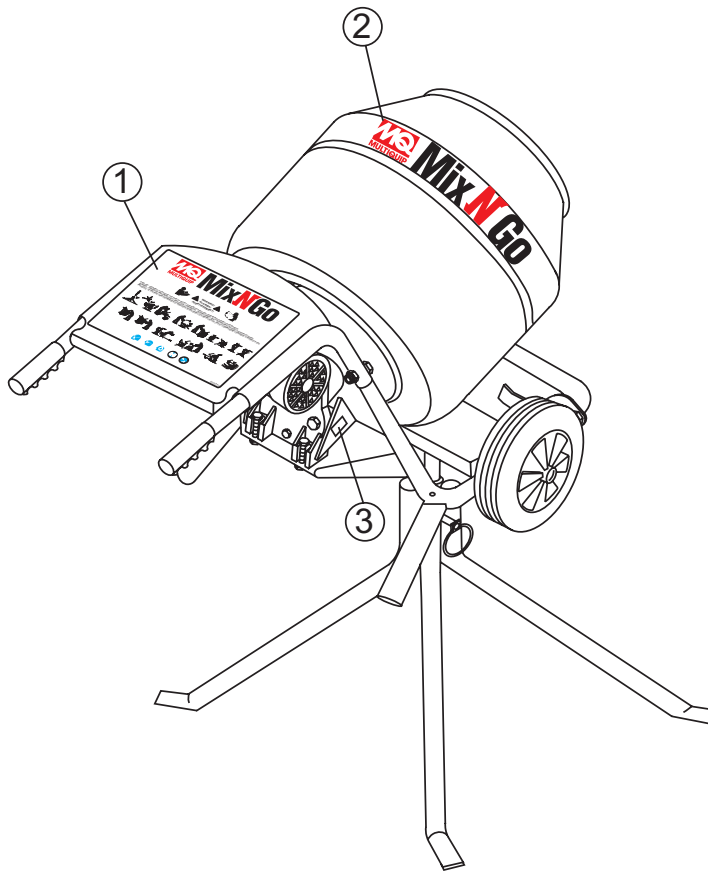

MIX N' GO MIXER — NAME PLATE AND DECALS

NAME PLATE AND DECALS

NAMEPLATE AND DECALS.

<u>NO</u>	<u>PART NO</u>	<u>PART NAME</u>	<u>QTY.</u>	<u>REMARKS</u>
1*	DCL251	DECAL: WARNING MQ	1	
2*	510165	DECAL: MQ MIX N GO	1	
3		DECAL: NAMEPLATE	1	CONTACT MQ PARTS DEPT.
4*	DCL250	DECAL: WARNING MAINTENANCE	1	

SEE DECAL ILLUSTRATIONS ON PAGES 11 AND 12.

MIX N' GO MIXER — MIXER ASSY.

MIXER ASSY.

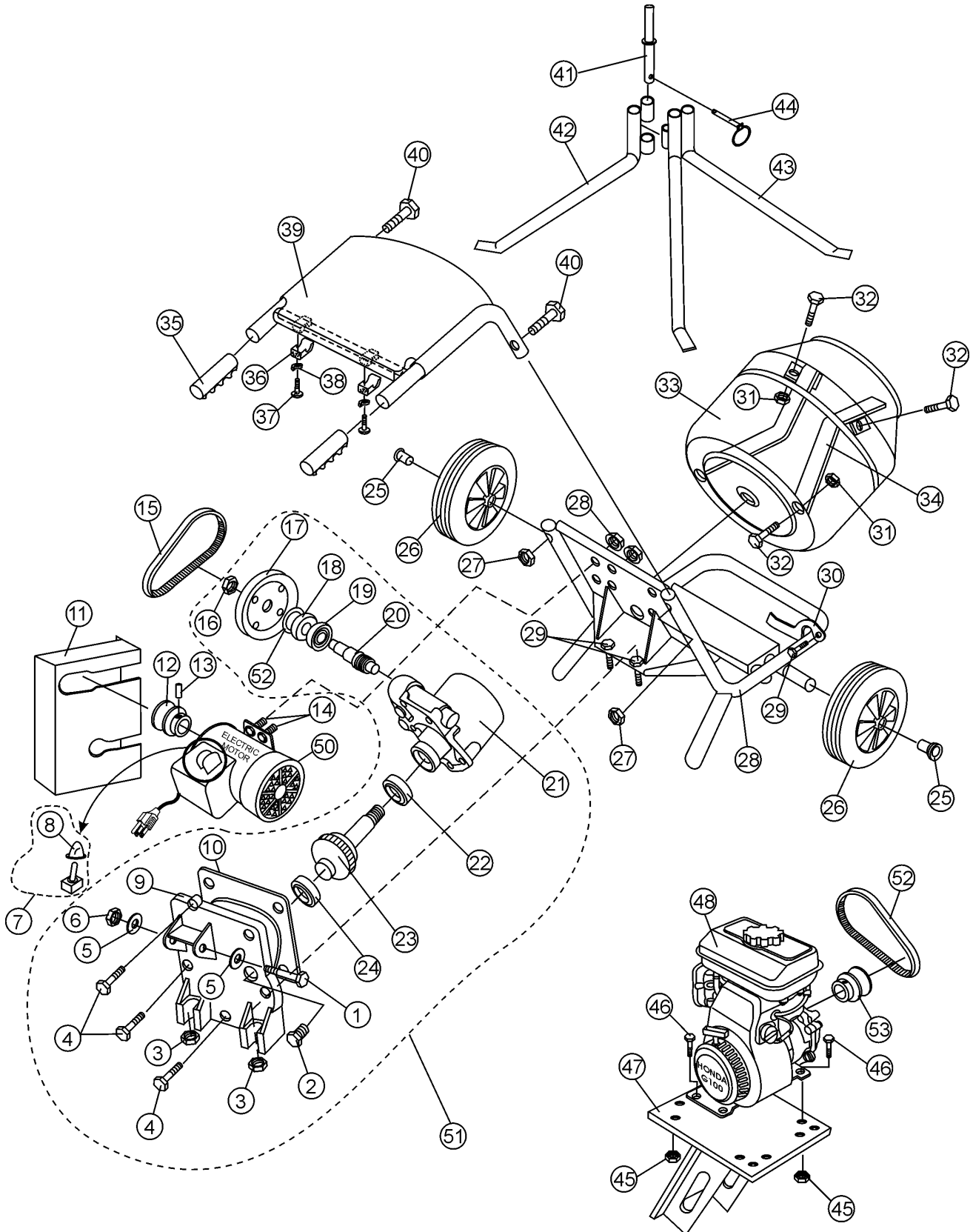

MIX N' GO MIXER — MIXER ASSY.

MIXER ASSY.

<u>NO.</u>	<u>PART NO.</u>	<u>PART NAME</u>	<u>QTY.</u>	<u>REMARKS</u>
1#	DM3150	HEX HEAD BOLT M12 x 70	1	
2#	DM1356	OIL FILLER PLUG M14 x 2 x 15L	1	
3#	DM1912	HEX NUT M10	2	
4#	DM355	HEX HEAD BOLT M8 x P1.25 x 24L	3	
5#	DM3151	FLAT WASHER M12	2	
6#	DM3152	HEX NUT M12	1	
7	SP9012	TOGGLE SWITCH	1	INCLUDES ITEM W/*
8*		SWITCH, BOOT	1	
9#	DM1320	GEAR BOX BACK COVER	1	
10#	DM1357	GEAR BOX SEAL		
11	DM1380	BELT GUARD	1	
12	DM1821	DRIVE PULLEY	1	ELECTRIC MOTOR ONLY
13	DM1822	SET SCREW M6 x 12L	1	
14	DM2020	BOLT M6 x 18	2	
15	DM1840	V-BELT, A23	1	ELECTRIC MOTOR ONLY
16#	DM1332	NUT M12	1	
17#	DM1810	GEARBOX PULLEY	1	
18#	DM1353	OIL SEAL 20 x 42.5 x 10	1	
19#	DM1352	BEARING RACE 6004	1	
20#	DM1331	WORMSHAFT	1	
21#	DM1310	GEARBOX CASE	1	
22#	DM1351	BEARING RACE 6006	1	
23#	DM1333	WORMSHAFT (DRUM)	1	
24	DM1351	BEARING RACE 6006	1	
25	DM1720	WHEEL RETAINER	2	
26	DM1711	WHEEL, RUBBER	2	
27	DM1641	HEX NUT M8	2	
28	DM2021	NUT	2	
28	DM1110	MAIN FRAME	1	
29	DM1911	HEX HEAD BOLT M10 x P1.5 x 40L	3	
30	DM1141	DRUM LOCK	1	
31	DM1527	HEX NUT M10	2	
32	DM1524	BOLT	2	
33	DM1400	STEEL DRUM	1	
34	DM1414	STEEL DRUM BLADE	2	
35	DM1613	HANDLE GRIP, RUBBER	2	
36	DM1630	TOP COVER CLAMP	2	
37	DM1631	SCREW 5.5 x 25	2	
38	DM1632	LOCK WASHER	2	
39	DM1620	TOP COVER, PLASTIC	1	
40	DM1640	BOLT M8 SPECIAL DOME HEAD	2	
41	DM1221	STAND, ADAPTER	1	
42	DM1212	STAND, BOTTOM LH (2 BOSS)	1	
43	DM1213	STAND, BOTTOM RH (1 BOSS)	1	
44	DM1231	CLIP LINCH PIN	1	
45	DM3050	NUT M8BOLT M8 x 35	4	
46	DM3051	BOLT M8 x 35	4	
47	DM3000	ENGINE MOUNT (GASOLINE)	1	
48	10649	ENGINE, 2.5 HP HONDA G100K2QA2	1	
49#	DM1358	RETAINER RING	1	
50	34579	MOTOR, ELECTRIC 3/4 H.P.	1	
51	DM1810	GEARBOX ASSEMBLY	1	INCLUDES ITEMS/#
52	MS01	V-BELT, A24	1	GASOLINE ENGINE ONLY
53	EM901006	DRIVE PULLEY	1	GASOLINE ENGINE ONLY

HONDA G100K2QA2 ENGINE — AIR CLEANER ASSY.

AIR CLEANER ASSY.

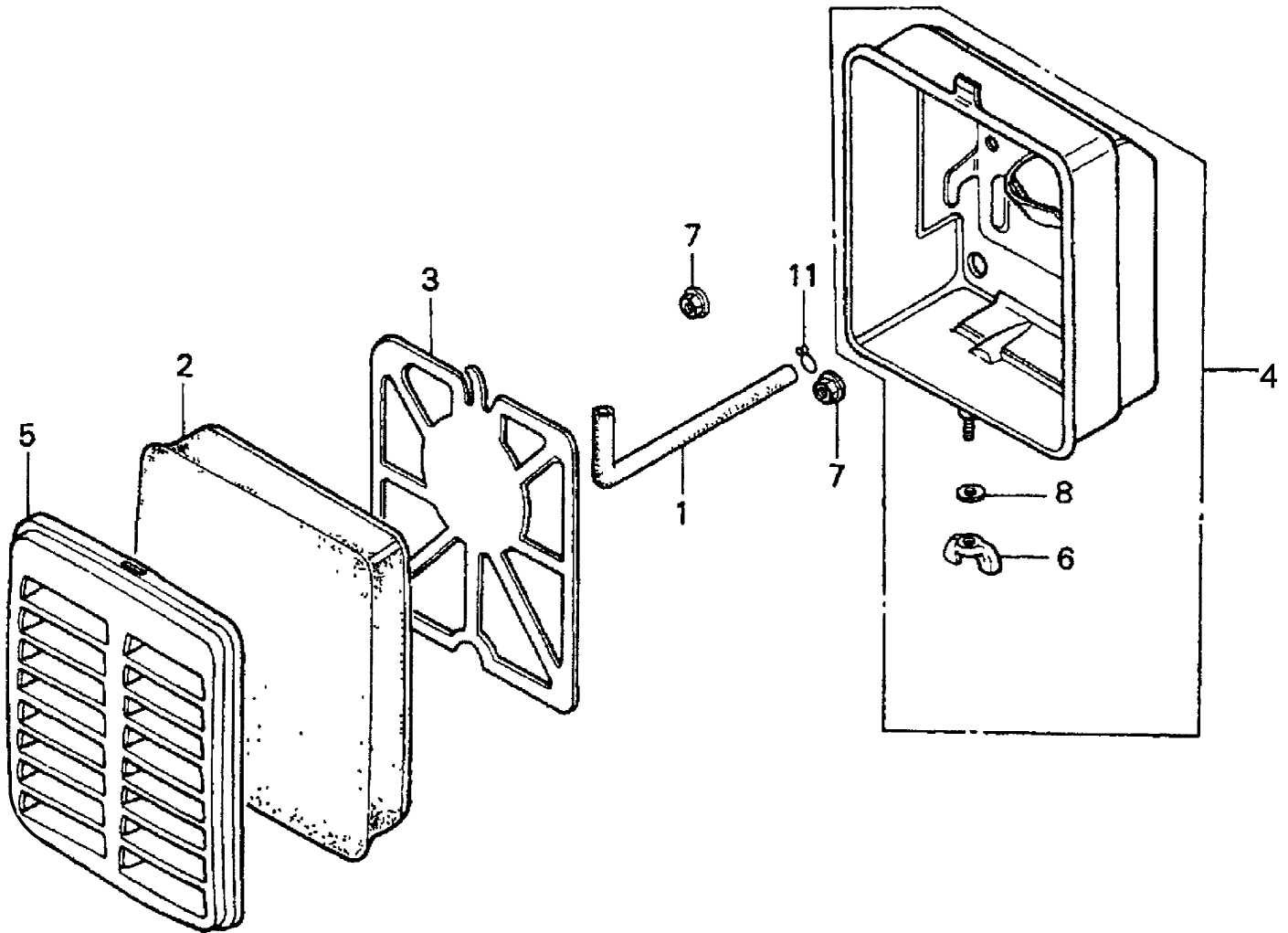

HONDA G100K2QA2 ENGINE — AIR CLEANER ASSY.

AIR CLEANER ASSY.

<u>NO.</u>	<u>PART NO.</u>	<u>PART NAME</u>	<u>QTY.</u>	<u>REMARKS</u>
1	15721896010	TUBE, BREATHER	1	
2	17211896000	ELEMENT, AIR CLEANER	1	
3	17212896000	GRID, AIR CLEANER	1	
4	17220ZG0000	HOUSING, AIR CLEANER	1 INCLUDES ITEMS W/*
5	17231ZG0000	COVER, AIR CLEANER	1	
6*	90325044000	WING NUT, TOOL BOX SETTING	1	
7	9405005000	NUT, FLANGE 5MM	2	
8*	9410106800	WASHER, PLAIN 6MM	1	

HONDA G100K2QA2 ENGINE — CAMSHAFT ASSY.

CAMSHAFT ASSY.

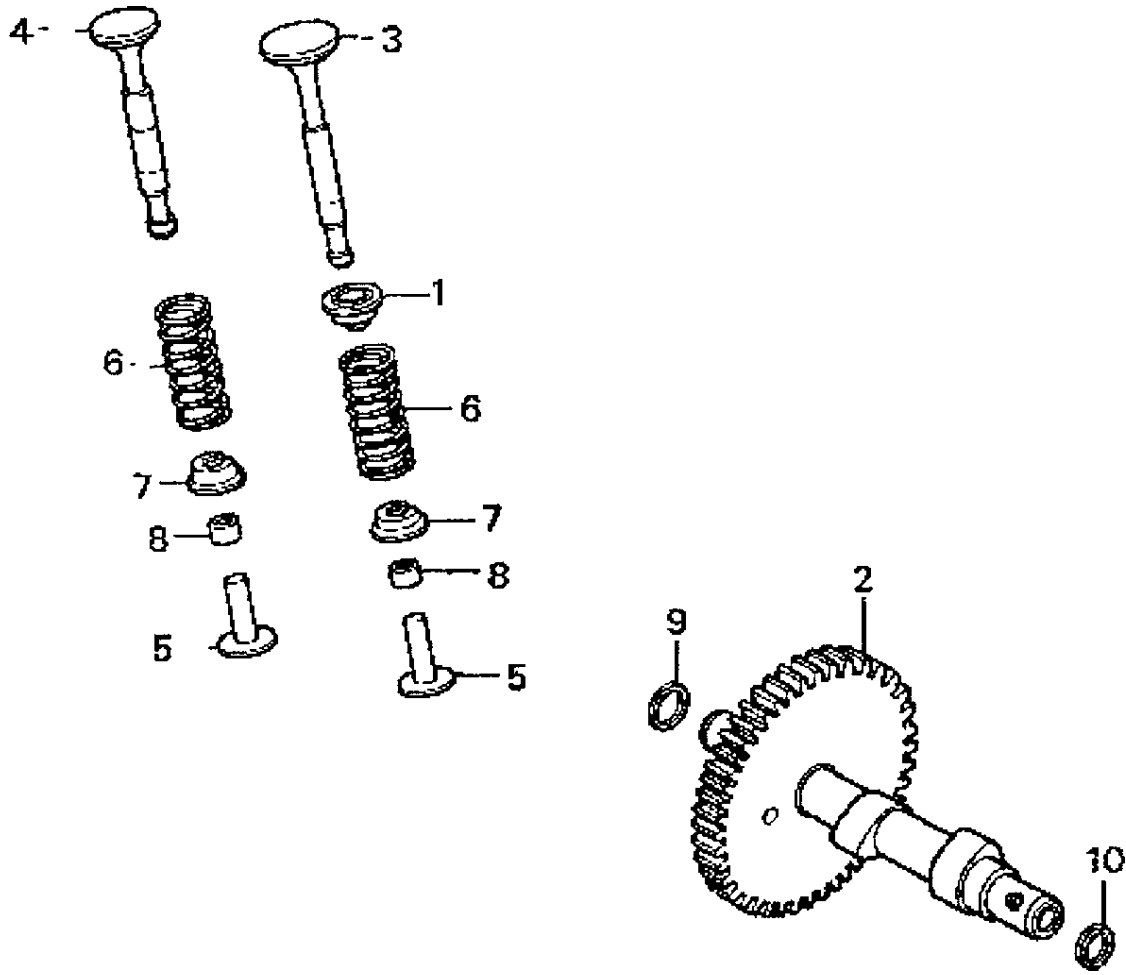

HONDA G100K2QA2 ENGINE — CAMSHAFT ASSY.

CAMSHAFT ASSY.

<u>NO.</u>	<u>PART NO.</u>	<u>PART NAME</u>	<u>QTY.</u>	<u>REMARKS</u>
1	12209ZG1H11	SEAL, VALVE STEM	1	
2	14111ZC0000	CAMSHAFT	1	
3	14711ZG1H10	VALVE, IN.	1	
4	14721ZG1H10	VALVE, EX.	1	
5	14732ZC0000	LIFTER, VALVE	2	
6	14751896000	SPRING, VALVE	2	
7	14771ZG0000	RETAINER, VALVE SPRING	2	
8	14801892000	ADJUSTER, TAPPET CLEARANCE 3.15	2	
8	14803892000	ADJUSTER, TAPPET CLEARANCE 3.25	2	
8	14806892000	ADJUSTER, TAPPET CLEARANCE 3.34	2	
8	14809892000	ADJUSTER, TAPPET CLEARANCE 3.43	2	
8	14812892000	ADJUSTER, TAPPET CLEARANCE 3.52	2	
8	14815892000	ADJUSTER, TAPPET CLEARANCE 3.61	2	
8	14818892000	ADJUSTER, TAPPET CLEARANCE 3.72	2	
8	14820892000	ADJUSTER, TAPPET CLEARANCE 3.82	2	
9	90452ZG0000	WASHER 12MM	1	
10	90452ZG0000	WASHER 12MM	1	

HONDA G100K2QA2 ENGINE — CARBURETOR ASSY.

CARBURETOR ASSY.

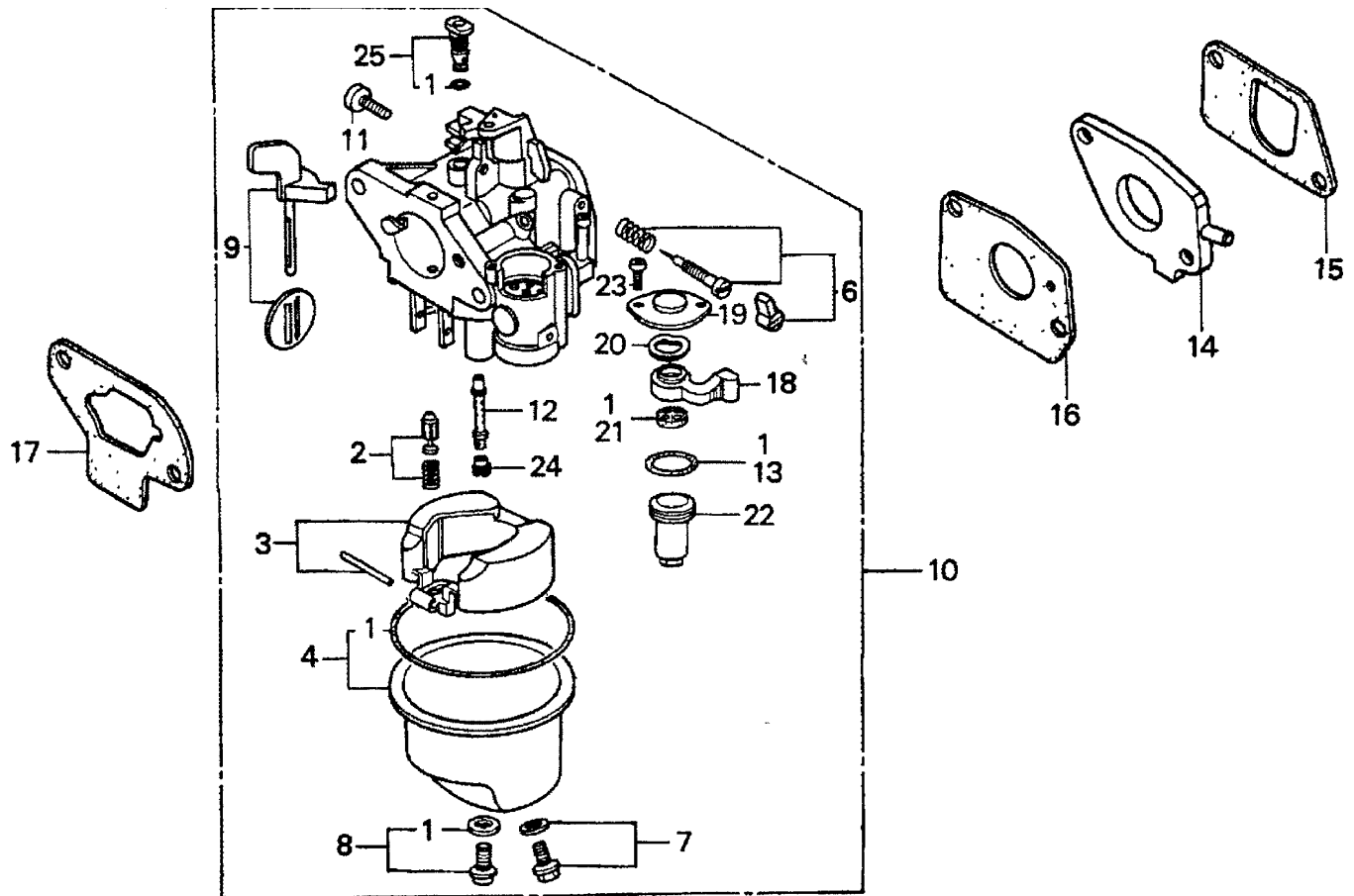

HONDA G100K2QA2 ENGINE — CARBURETOR ASSY.

CARBURETOR ASSY.

<u>NO.</u>	<u>PART NO.</u>	<u>PART NAME</u>	<u>QTY.</u>	<u>REMARKS</u>
1*	16010ZG0812	GASKET SET	1	
2*	16011ZE0005	VALVE SET, FLOAT	1	
3*	16013ZG0811	FLOAT SET	1	
4*	16015ZG0811	CHAMBER SET, FLOAT	1	
6*	16016ZG0W00	SCREW SET	1	
7*	16024ZE1811	SCREW SET, DRAIN	1	
8*	16028ZG0811	SCREW SET	1	
9*	16044ZG0W00	CHOKE SET	1	
10	16100ZG0W02	CARBURETOR ASSEMBLY BF11B B	1	INCLUDES ITEMS W/*
11*	16124ZE0005	SCREW, THROTTLE STOP	1	
12*	16166ZG0W01	NOZZLE, MAIN	1	
13*	16173ZG0811	O-RING	1	
14	16211ZG0020	INSULATOR, CARBURETOR	1	
15	16212ZG0800	GASKET, INSULATOR	1	
16	16221ZG0801	GASKET, CARBURETOR	1	
17	16269ZG0800	GASKET, AIR CLEANER	1	
18*	16953ZG0812	LEVER, VALVE	1	
19*	16954ZE1812	PLATE, LEVER SETTING	1	
20*	16956ZE1811	SPRING, VALVE LEVER	1	
21*	16957ZE1812	GASKET, VALVE	1	
22*	16967ZG0811	CUP, FUEL STRAINER	1	
23*	93500030060H	SCREW, PAN 3X6	2	
24	99101ZG00500	JET, MAIN #50 (OPTIONAL)	1	
24	99101ZG00520	JET, MAIN #52 (OPTIONAL)	1	
24*	99101ZG00550	JET, MAIN #55	1	
25*	99204ZE00350	JET SET, PILOT #35	1	

HONDA G100K2QA2 ENGINE — CONTROL ASSY.

CONTROL ASSY.

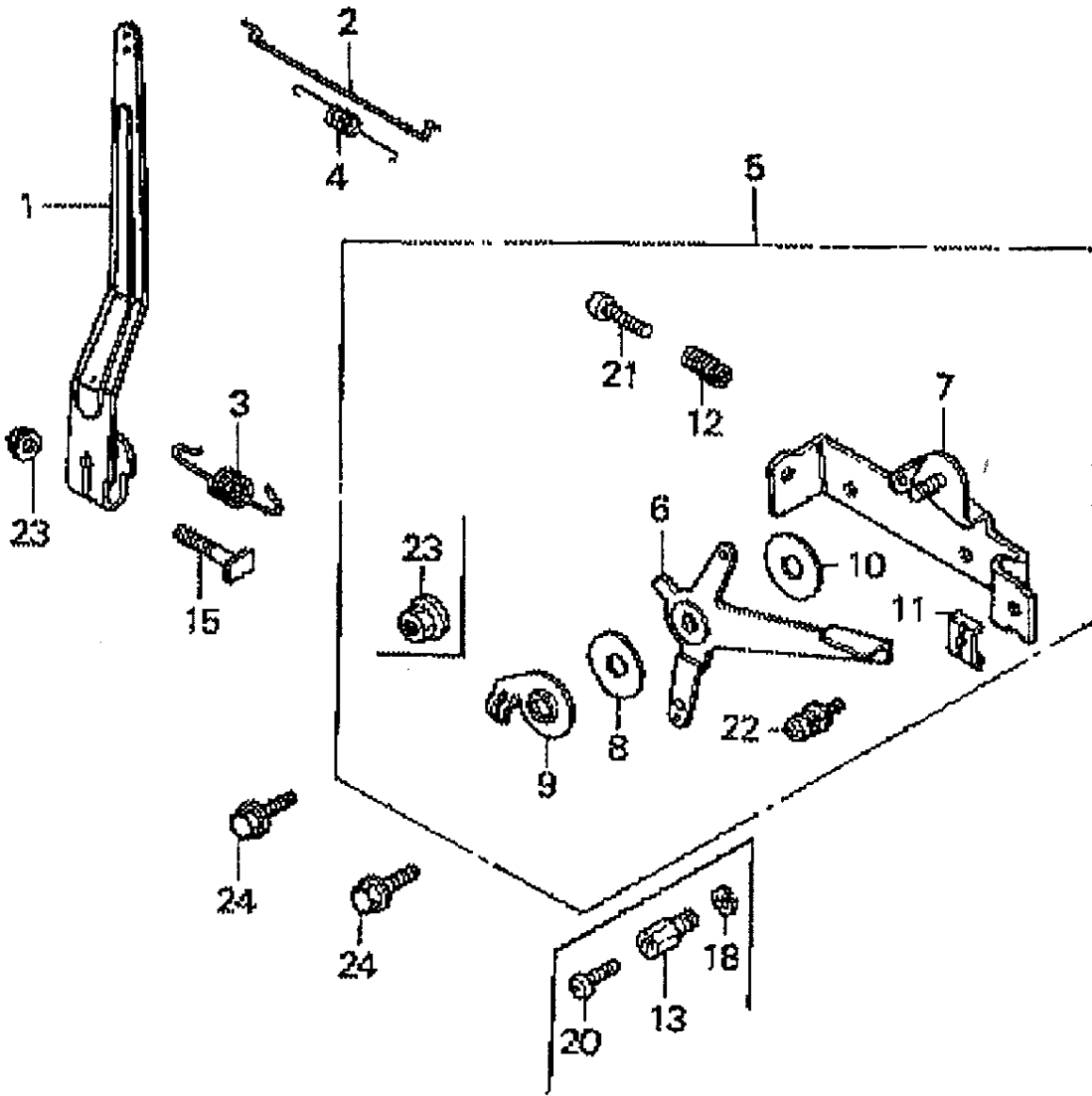

HONDA G100K2QA2 ENGINE — CONTROL ASSY.

CONTROL ASSY.

<u>NO.</u>	<u>PART NO.</u>	<u>PART NAME</u>	<u>QTY.</u>	<u>REMARKS</u>
1	16551ZG0000	ARM, GOVERNOR	1	
2	16555ZG0000	ROD, GOVERNOR	1	
3	16561ZG0000	SPRING, GOVERNOR	1	
4	16562ZG0000	SPRING, THROTTLE RETURN	1	
5	16570ZG0W00	CONTROL ASSEMBLY, STANDARD	1	INCLUDES ITEMS W/*
6*	16571ZG0000	LEVER, CONTROL (STANDARD)	1	
7*	16572ZG0000	BASE, CONTROL (STANDARD)	1	
8*	16574ZE1000	SPRING, LEVER	1	
9*	16575ZG0000	WASHER, CONTROL LEVER	1	
10*	16578ZE1000	SPACER, CONTROL LEVER	1	
11*	16576891000	HOLDER, CABLE	1	
12*	16584883300	SPRING, CONTROL ADJUSTING	1	
13	16594883010	HOLDER, WIRE (OPTIONAL)	1	
15	90015ZE5010	BOLT, GOVERNOR ARM	1	
18	90605230000	CIRCLIP 5MM (OPTIONAL)	1	
20	93500040080A	SCREW, PAN 4X8 (OPTIONAL)	1	
21*	93500050250A	SCREW, PAN 5X25	1	
22*	93500050160A	SCREW, PAN 5X16	1	
23*	9405006000	NUT, FLANGE 6MM	2	
24	90013883000	BOLT, FLANGE 6X12 (CT200)	2	

HONDA G100K2QA2 ENGINE — CRANKCASE COVER ASSY.

CRANKCASE COVER ASSY.

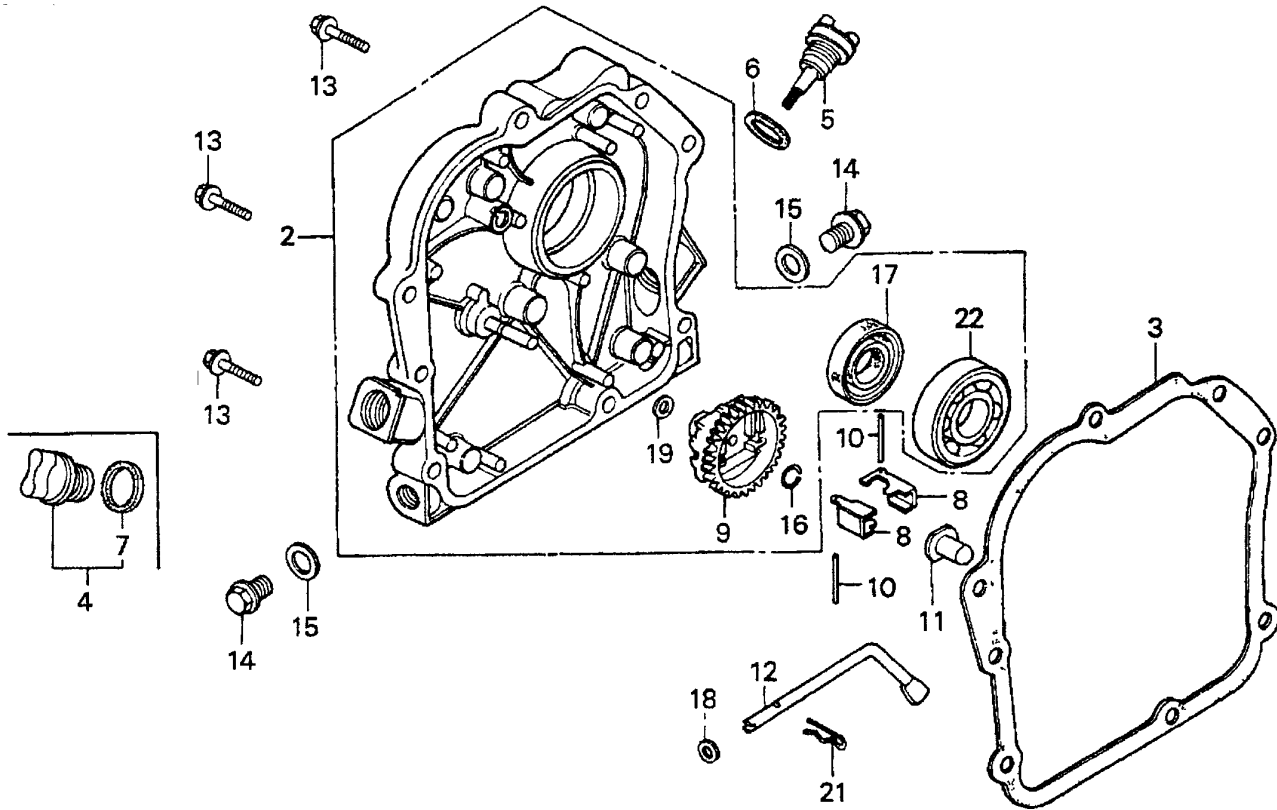

HONDA G100K2QA2 ENGINE — CRANKCASE COVER ASSY.

CRANKCASE COVER (1) ASSY.

<u>NO.</u>	<u>PART NO.</u>	<u>PART NAME</u>	<u>QTY.</u>	<u>REMARKS</u>
2	11300ZG0010	COVER ASSEMBLY, CRANKCASE	1	INCLUDES ITEMS W/*
3	11381ZG0800	GASKET, CASE COVER	1	
4	15600ZG4003	CAP ASSEMBLY, OIL FILLER	1	INCLUDES ITEMS W/#
5	15620ZG0003	CAP, OIL FILLER	1	
6	15625ZG0000	GASKET, OIL FILLER CAP	1	
7#	15625ZE1003	GASKET, OIL FILLER CAP	1	
8	16511896000	WEIGHT, GOVERNOR	2	
9*	16512ZG0000	HOLDER, GOVERNOR WEIGHT	1	
10	16513ZE1000	PIN, GOVERNOR WEIGHT	2	
11	16531ZG0000	SLIDER, GOVERNOR	1	
12	16541896000	SHAFT, GOVERNOR ARM	1	
13	90015883000	BOLT, FLANGE 6X28	6	
14	90131ZE1000	BOLT, DRAIN PLUG	2	
15	90601ZE1000	WASHER, DRAIN PLUG10.2MM	2	
16*	90602ZE1000	CLIP, GOVERNOR HOLDER	1	
17*	91202892004	OIL SEAL 17X30X6 (NOK)	1	
18	9410105000	WASHER, PLAIN 5MM	1	
19*	9410106800	WASHER, PLAIN 6MM	1	
21	9425108000	PIN, LOCK 8MM	1	
22*	961006203000	BEARING, RADIAL BALL 6203	1	

HONDA G100K2QA2 ENGINE — CRANKSHAFT ASSY.

CRANKSHAFT ASSY.

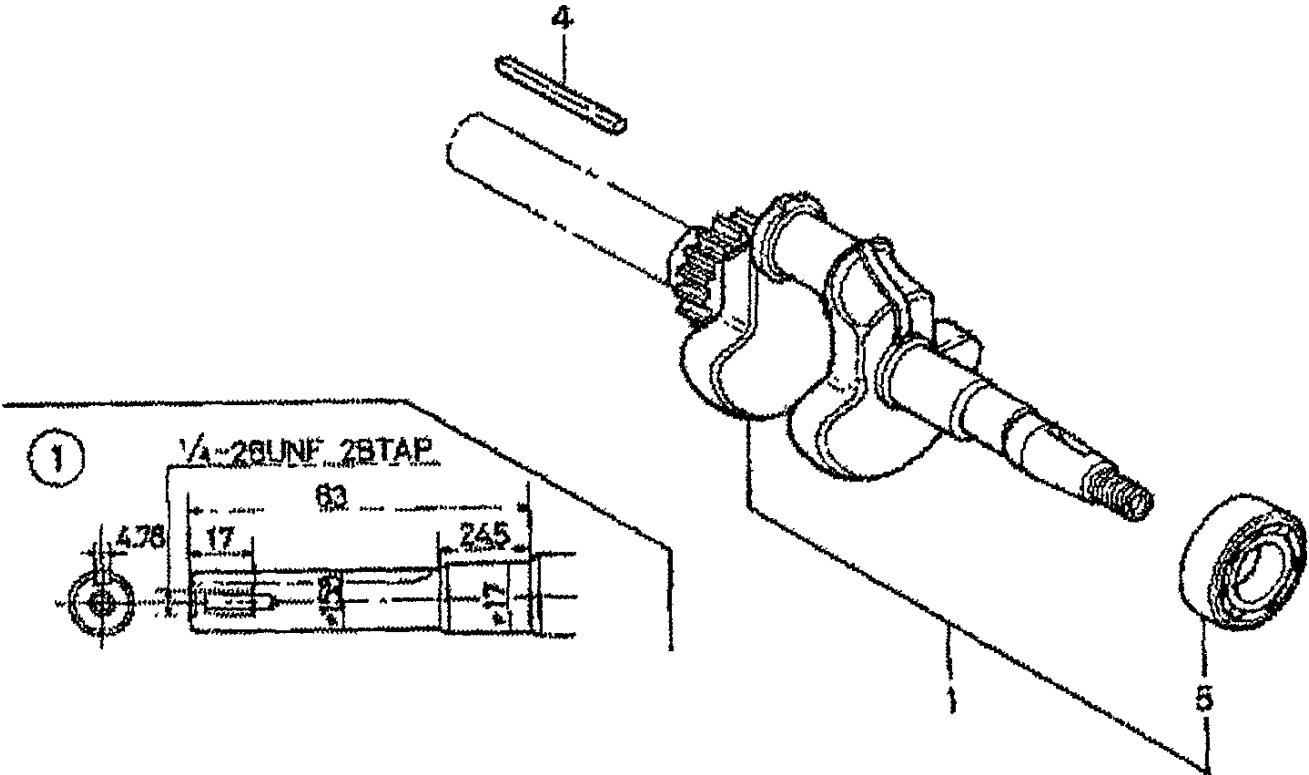

HONDA G100K2QA2 ENGINE — CRANKSHAFT ASSY.

CRANKSHAFT ASSY.

<u>NO.</u>	<u>PART NO.</u>	<u>PART NAME</u>	<u>QTY.</u>	<u>REMARKS</u>
1	13310ZG0601	CRANKSHAFT, Q-TYPE	1.....	INCLUDES ITEMS W/*
4	90745ZE1600	KEY 4.78X4.78X38	1	
5*	961006203000	BEARING, RADIAL BALL	1	

HONDA G100K2QA2 ENGINE — CYLINDER BARREL ASSY.

CYLINDER BARREL ASSY.

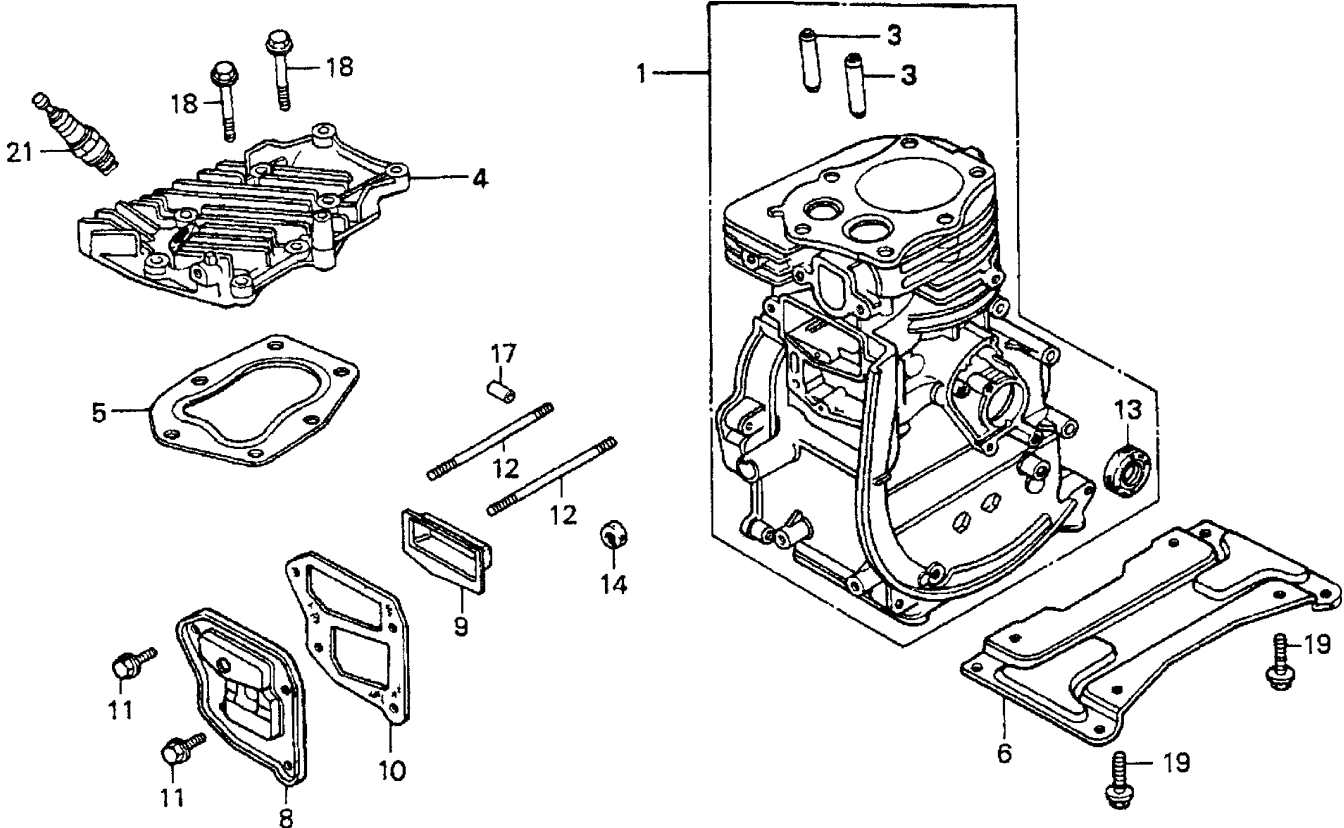

HONDA G100K2QA2 ENGINE — CYLINDER BARREL ASSY.

CYLINDER BARREL ASSY.

<u>NO.</u>	<u>PART NO.</u>	<u>PART NAME</u>	<u>QTY.</u>	<u>REMARKS</u>
1	12000ZG0020	CYLINDER ASSEMBLY	1	INCLUDES ITEMS W/*
3*	12133896306	GUIDE, VALVE OS (OPTIONAL)	2	
4	12221ZG0030	CYLINDER HEAD	1	
5	12281ZC0003	GASKET, CYLINDER HEAD	1	
6	12351ZG0810	BED, ENGINE Q-TYPE	1	
8	12361ZG0000	COVER, TAPPET ROOM	1	
9	12370ZG0000	SEPARATOR, INNER	1	
10	12375ZG0010	GASKET, TAPPET COVER	1	
11	90002892000	BOLT, FLANGE 5X10	4	
12	90041896000	BOLT, STUD 5X80	2	
13*	91202892004	OIL SEAL 17X30X6 (NOK)	1	
14	91231816000	OIL SEAL	1	
17	9430108140	PIN A, DOWEL 8X14	2	
18	958010603500	BOLT, FLANGE 6X35	6	
19	957010801800	BOLT, FLANGE 8X18	4	
21	9807354776	SPARK PLUG, BRMR4A (NGK)	1	

HONDA G100K2QA2 ENGINE — FAN COVER ASSY.

FAN COVER ASSY.

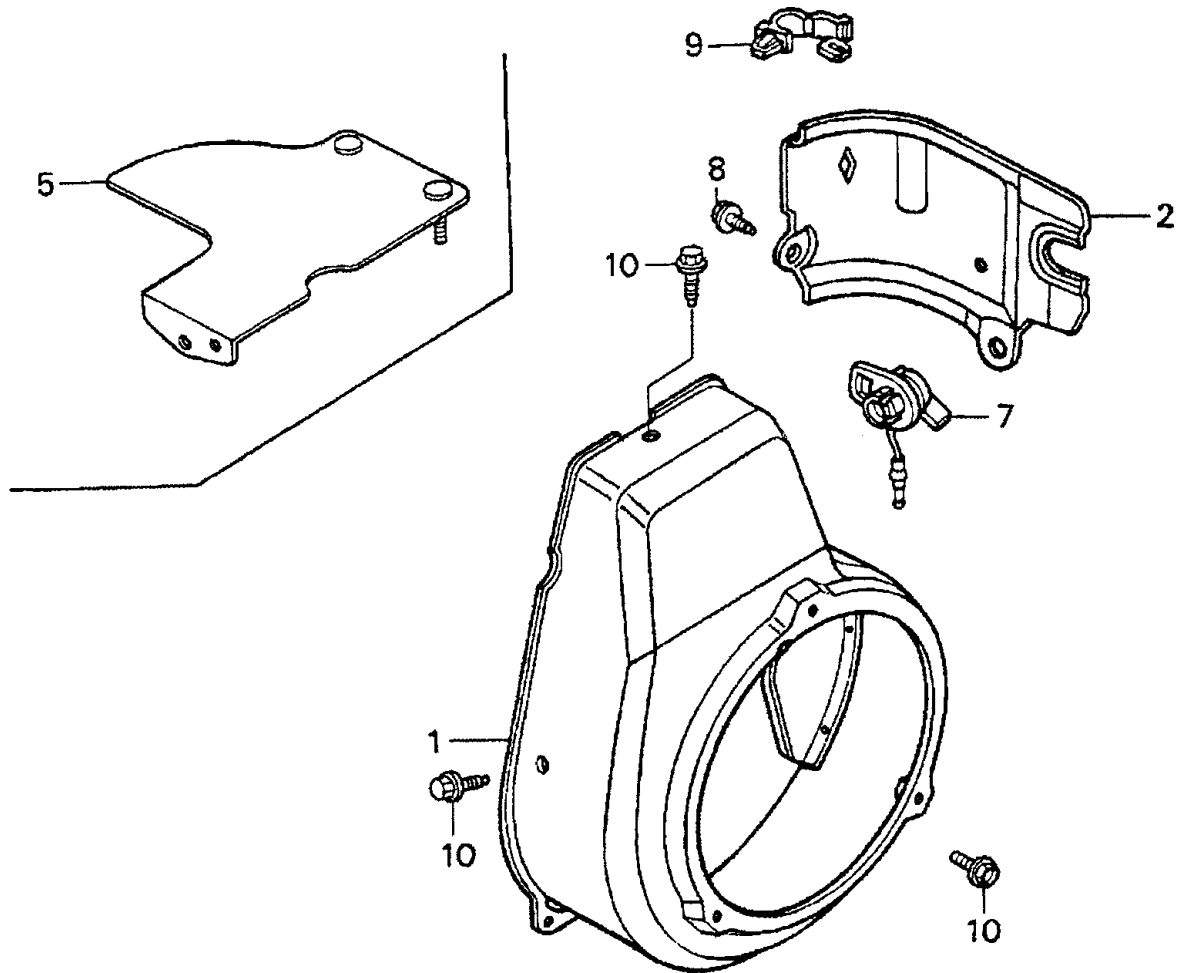

HONDA G100K2QA2 ENGINE — FAN COVER ASSY.

FAN COVER ASSY.

<u>NO.</u>	<u>PART NO.</u>	<u>PART NAME</u>	<u>QTY.</u>	<u>REMARKS</u>
1	19610ZG0W20ZB	COVER, FAN *R8* (BRIGHT RED)	1	
2	19631ZG0000	SHROUD	1	
5	19721ZG0W20	COVER, TOP	1	
7	36100ZE1015	SWITCH ASSEMBLY, ENGINE STOP	1	
8	90013883000	BOLT, FLANGE 6X12 (CT200)	2	
9	90652SB2023	CLIP, TUBE 7MM	1	
10	90013883000	BOLT, FLANGE 6X12 (CT200)	4	

HONDA G100K2QA2 ENGINE — FLYWHEEL ASSY.

FLYWHEEL ASSY.

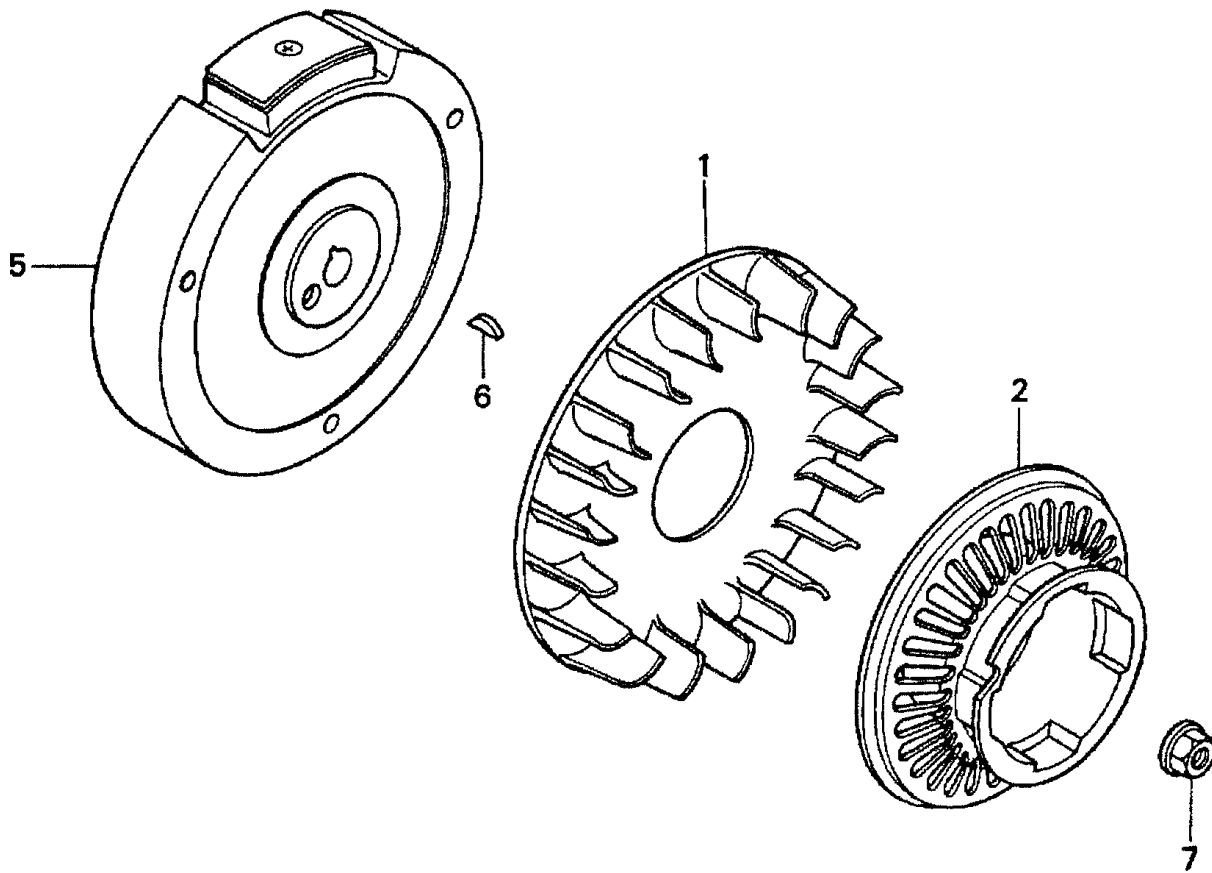

HONDA G100K2QA2 ENGINE — FLYWHEEL ASSY.

FLYWHEEL ASSY.

<u>NO.</u>	<u>PART NO.</u>	<u>PART NAME</u>	<u>QTY.</u>	<u>REMARKS</u>
1	19511ZG0W00	FAN, COOLING	1	
2	28450ZG0822	PULLEY, STARTER	1	
5	31100ZG0010	FLYWHEEL	1	
6	90741035000	KEY, WOODRUFF 3X5	1	
7	9405012000	NUT, FLANGE 12MM	1	

HONDA G100K2QA2 ENGINE — FUEL TANK ASSY.

FUEL TANK ASSY.

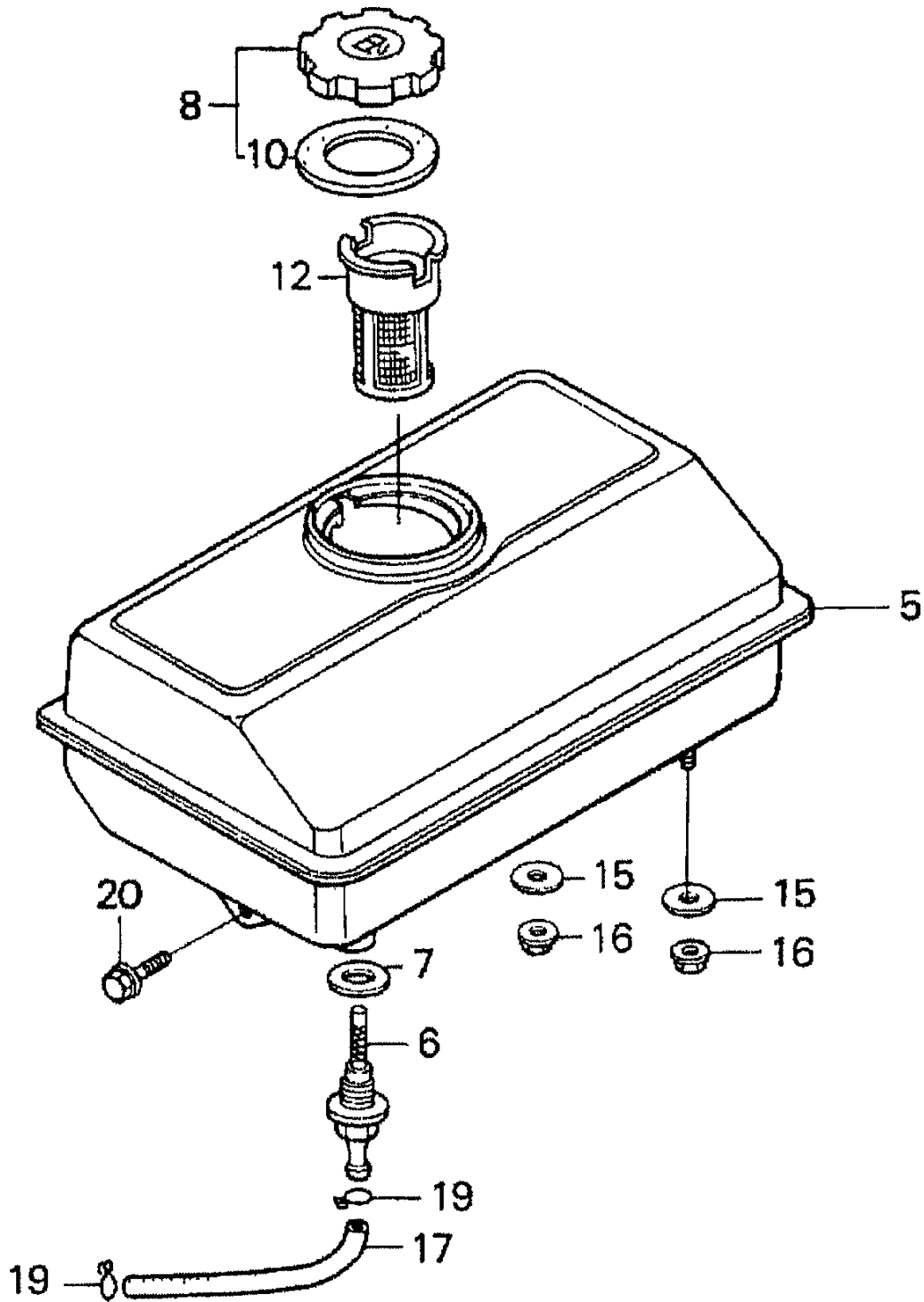

HONDA G100K2QA2 ENGINE — FUEL TANK ASSY.

FUEL TANK ASSY.

<u>NO.</u>	<u>PART NO.</u>	<u>PART NAME</u>	<u>QTY.</u>	<u>REMARKS</u>
5	17510ZGOW00ZA	TANK, FUEL *NH31* (MCKINLEY WHITE)	1	
6	16955ZE1000	JOINT, FUEL TANK	1	
7	91353671003	O-RING 13.5X1.5 (ARAI)	1	
8	17620ZH7023	CAP, FUEL FILLER	1	INCLUDES ITEMS W/*
9	17620ZE2W00	CAP, FUEL FILLER	1	
10*	17631ZH7003	GASKET, FUEL FILLER CAP	1	
12	17672ZE2W01	FILTER, FUEL	1	
16	9405006000	NUT, FLANGE 6MM	2	
17	950014500360M	BULK HOSE, FUEL (4.5X3000) (4.5X55)	1	
19	9500202080	CLIP, TUBE B8	2	
20	957010601400	BOLT, FLANGE 6X14	1	

HONDA G100K2QA2 ENGINE — GASKET KIT ASSY.

GASKET KIT ASSY.

<u>NO.</u>	<u>PART NO.</u>	<u>PART NAME</u>	<u>QTY.</u>	<u>REMARKS</u>
	061A1ZG0801	GASKET KIT	1	INCLUDES ITEMS W/*
1*	11381ZG0800	GASKET, CASE COVER	1	
2*	12281ZC0003	GASKET, CYLINDER HEAD	1	
3*	12375ZG0010	GASKET, TAPPET COVER	1	
5*	16212ZG0800	GASKET, INSULATOR	1	
7*	16221ZG0801	GASKET, CARBURETOR	1	
8*	16269ZG0800	GASKET, AIR CLEANER	1	
10*	18381ZG0800	GASKET, MUFFLER	1	

HONDA G100K2QA2 ENGINE — IGNITION COIL ASSY.

IGNITION COIL ASSY.

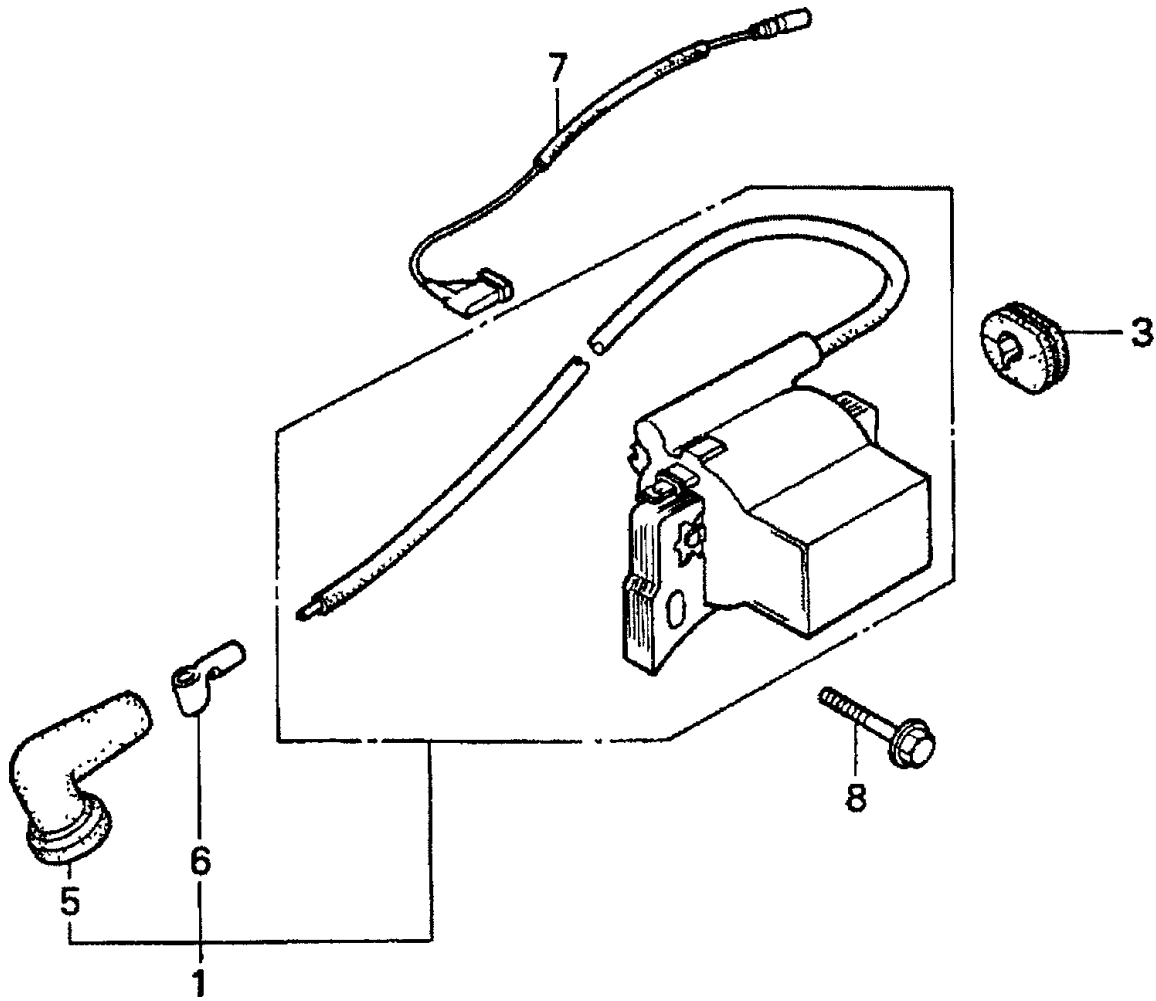

HONDA G100K2QA2 ENGINE — IGNITION COIL ASSY.

IGNITION COIL ASSY.

<u>NO.</u>	<u>PART NO.</u>	<u>PART NAME</u>	<u>QTY.</u>	<u>REMARKS</u>
1	30500ZG0W01	COIL ASSEMBLY, IGNITION	1	INCLUDES ITEMS W/*
3	30563ZG0000	GROMMET, IGNITION WIRE	1	
5*	30701888014	CAP, IGNITION (TOYO)	1	
6*	30702888003	TERMINAL, PLUG	1	
7	36101ZG0000	WIRE, STOP SWITCH	1	
8	90121952000	BOLT, FLANGE 6X25	2	

HONDA G100K2QA2 ENGINE — MUFFLER ASSY.

MUFFLER ASSY.

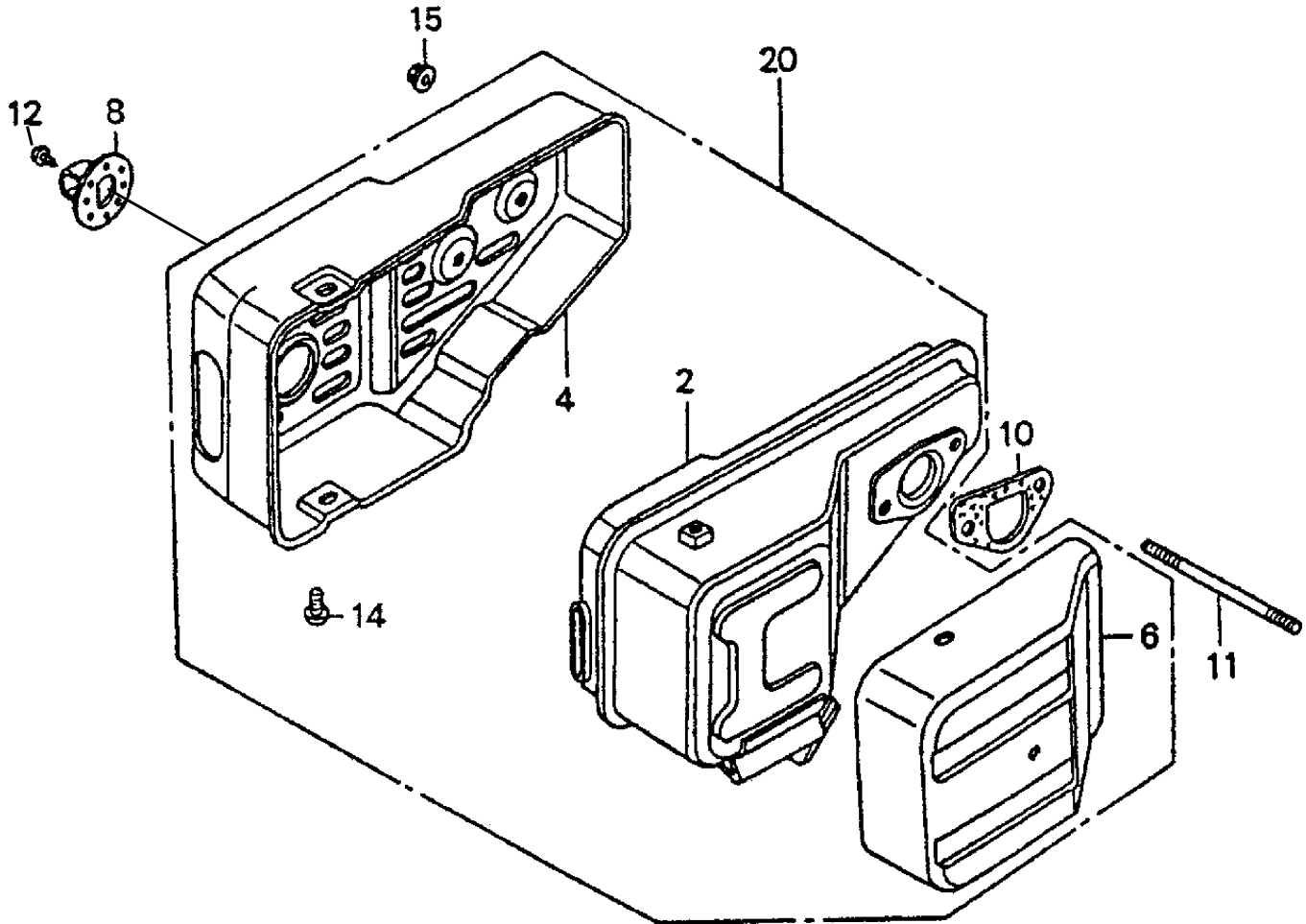

HONDA G100K2QA2 ENGINE — MUFFLER ASSY.

MUFFLER ASSY.

<u>NO.</u>	<u>PART NO.</u>	<u>PART NAME</u>	<u>QTY.</u>	<u>REMARKS</u>
2*	18310ZG0830	MUFFLER (W/PROTECTOR)	1	
4*	18320ZG0810	PROTECTOR, MUFFLER	1	
6*	18321896000	SEPARATOR, MUFFLER	1	
8	18331896620	DEFLECTOR, MUFFLER (OPTIONAL)	1	
10	18381ZG0800	GASKET, MUFFLER	1	
11	90046ZG0000	BOLT, STUD 6X50	2	
12	90002ZG0003	SCREW, TAPPING 4X8 (OPTIONAL)	2	
14*	93500060060A	SCREW, PAN 6X6	2	
15	9405006000	NUT, FLANGE 6MM	2	
20	18300ZG0U01	MUFFLER ASSEMBLY	1	INCLUDES ITEMS W/*

HONDA G100K2QA2 ENGINE — PISTON ASSY.

PISTON ASSY.

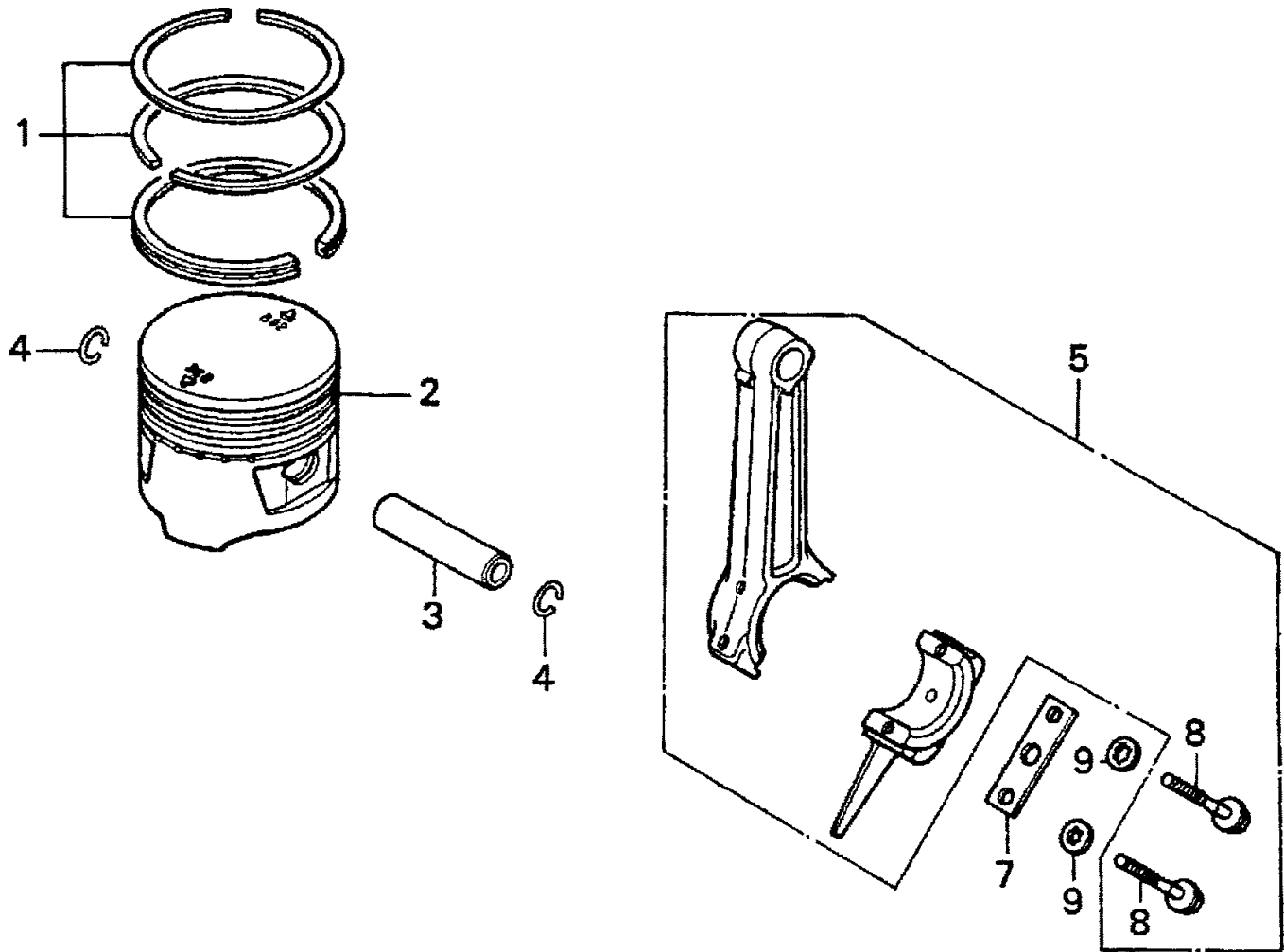

HONDA G100K2QA2 ENGINE — PISTON ASSY.

PISTON ASSY.

<u>NO.</u>	<u>PART NO.</u>	<u>PART NAME</u>	<u>QTY.</u>	<u>REMARKS</u>
1	13010ZC0003	RING SET, PISTON -STANDARD	1	
1	13011ZC0003	RING SET, PISTON - OS 0.25 (OPTIONAL)	1	
1	13012ZC0003	RING SET, PISTON - OS 0.50 (OPTIONAL)	1	
1	13013ZC0003	RING SET, PISTON - 0.75 (OPTIONAL)	1	
2	13101ZC0003	PISTON - STANDARD	1	
2	13102ZC0003	PISTON - OS 0.25 (OPTIONAL)	1	
2	13103ZC0003	PISTON- OS 0.50 (OPTIONAL)	1	
2	13104ZC0003	PISTON- 0.75 (OPTIONAL)	1	
3	13111892000	PIN, PISTON	1	
4	13115147000	CLIP, PISTON PIN 10MM	2	
5	13200ZG0000	ROD ASSY., CONNECTING STANDARD	1	INCLUDES ITEMS W/*
5	13200ZG0305	ROD ASSY., CONNECTING (UNDER SIZE) OPTIONAL	1	INCLUDES ITEMS W/*
8*	90001ZG0000	BOLT, CONNECTING ROD	2	

HONDA G100K2QA2 ENGINE — RECOIL STARTER ASSY.

RECOIL STARTER ASSY.

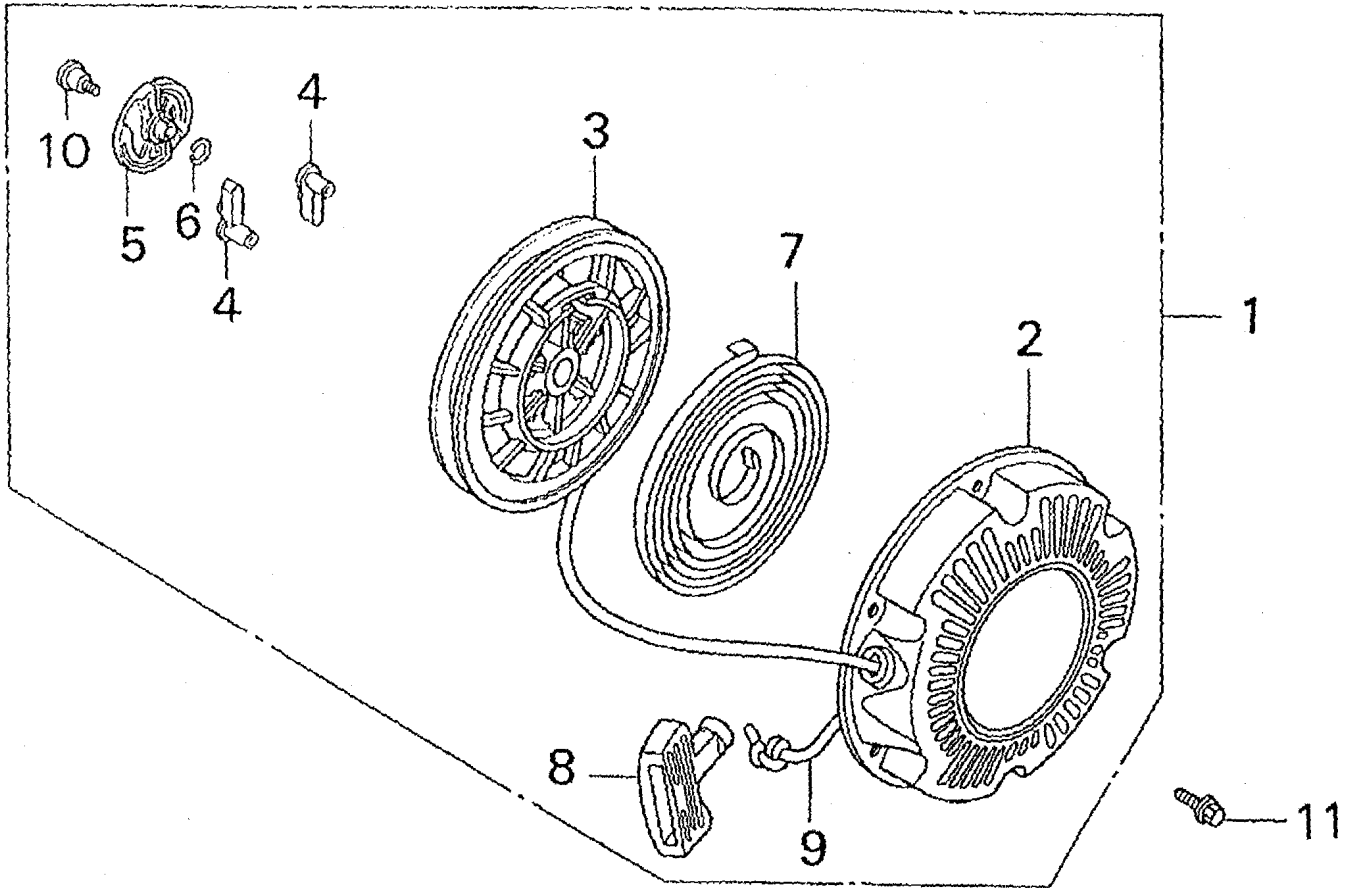

HONDA G100K2QA2 ENGINE — RECOIL STARTER ASSY.

RECOIL STARTER (3) ASSY.

<u>NO.</u>	<u>PART NO.</u>	<u>PART NAME</u>	<u>QTY.</u>	<u>REMARKS</u>
1	28400ZGOWO2ZC	STARTER ASSY., RECOIL *R8*	1	INCLUDES ITEMS W/*
2*	28410ZGOWO2ZC	CASE, RECOIL STARTER *R8*	1	
3*	28421ZGOWO2	REEL, RECOIL STARTER	1	
4*	28422ZGOWO2	RATCHET, STARTER	1	
5*	28433ZGOWO2	GUIDE, RATCHET	1	
6*	28441ZH8003	SPRING, FRICTION	1	
7*	28442ZH8003	SPRING, RECOIL STARTER	1	
8*	28461ZGOWO2	GRIP, STARTER	1	
9*	28462ZGOWO2	ROPE, RECOIL STARTER	1	
10*	9000-ZH8003	SCREW, SETTING	3	
11	957010600800	BOLT, FLANGE 6X8	1	

HONDA G100K2QA2 ENGINE — LABELS

LABELS

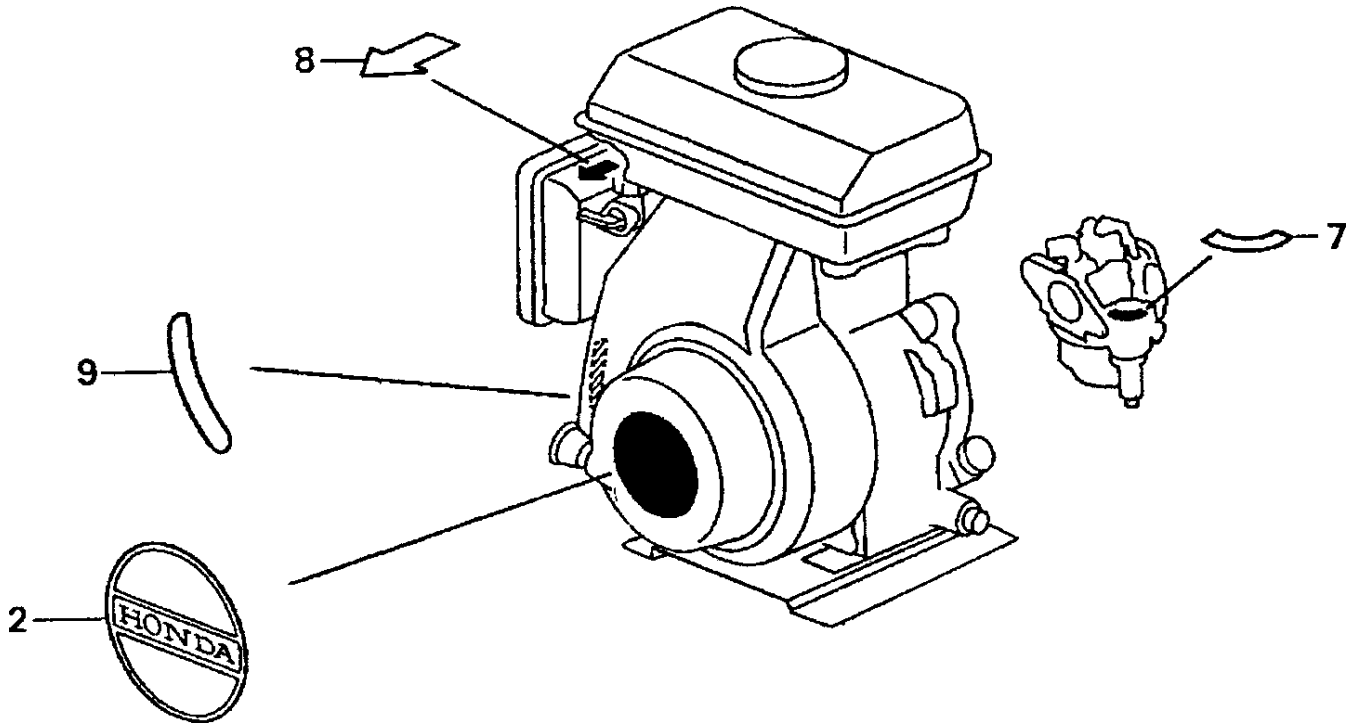

HONDA G100K2QA2 ENGINE — LABELS

LABELS

<u>NO.</u>	<u>PART NO.</u>	<u>PART NAME</u>	<u>QTY.</u>	<u>REMARKS</u>
2	87521ZG0W50	EMBLEM	1	
4	87522ZE1810	MARK, CAUTION (EXTERNAL)	1	
7	87528ZG0810	MARK, EXTERNAL	1	
8	87528883661	MARK, CHOKE	1	
9	87532ZG0810	MARK, THROTTLE(ENGLISH, FRENCH, GERMAN)	1	

PAYMENT TERMS

Terms of payment for parts are net 10 days.

FREIGHT POLICY

All parts orders will be shipped collect or prepaid with the charges added to the invoice. All shipments are F.O.B. point of origin. Multiquip's responsibility ceases when a signed manifest has been obtained from the carrier, and any claim for shortage or damage must be settled between the consignee and the carrier.

MINIMUM ORDER

The minimum charge for orders from Multiquip is \$15.00 net. Customers will be asked for instructions regarding handling of orders not meeting this requirement.

RETURNED GOODS POLICY

Return shipments will be accepted and credit will be allowed, subject to the following provisions:

1. A Returned Material Authorization must be approved by Multiquip prior to shipment.
2. To obtain a Return Material Authorization, a list must be provided to Multiquip Parts Sales that defines item numbers, quantities, and descriptions of the items to be returned.
 - a. The parts numbers and descriptions must match the current parts price list.
 - b. The list must be typed or computer generated.
 - c. The list must state the reason(s) for the return.
 - d. The list must reference the sales order(s) or invoice(s) under which the items were originally purchased.
 - e. The list must include the name and phone number of the person requesting the RMA.
3. A copy of the Return Material Authorization must accompany the return shipment.

4. Freight is at the sender's expense. All parts must be returned freight prepaid to Multiquip's designated receiving point.
5. Parts must be in new and resalable condition, in the original Multiquip package (if any), and with Multiquip part numbers clearly marked.
6. The following items are not returnable:
 - a. Obsolete parts. (If an item is listed in the parts price book as being replaced by another item, it is obsolete.)
 - b. Any parts with a limited shelf life (such as gaskets, seals, "O" rings, and other rubber parts) that were purchased more than six months prior to the return date.
 - c. Anyline item with an extended dealer net price of less than \$5.00.
 - d. Special order items.
 - e. Electrical components.
 - f. Paint, chemicals, and lubricants.
 - g. Decals and paper products.
 - h. Items purchased in kits.
7. The sender will be notified of any material received that is not acceptable.
8. Such material will be held for 5 working days from notification, pending instructions. If a reply is not received within 5 days, the material will be returned to the sender at his expense.
9. Credit on returned parts will be issued at dealer net price at time of the original purchase, less a 15% restocking charge.
10. In cases where an item is accepted for which the original purchase document can not be determined, the price will be based on the list price that was effective twelve months prior to the RMA date.
11. Credit issued will be applied to future purchases only.

PRICING AND REBATES

Prices are subject to change without prior notice. Price changes are effective on a specific date and all orders received on or after that date will be billed at the revised price. Rebates for price declines and added charges for price increases will not be made for stock on hand at the time of any price change.

Multiquip reserves the right to quote and sell direct to Government agencies, and to Original Equipment Manufacturer accounts who use our products as integral parts of their own products.

SPECIAL EXPEDITING SERVICE

A \$20.00 to \$50.00 surcharge will be added to the invoice for special handling including bus shipments, insured parcel post or in cases where Multiquip must personally deliver the parts to the carrier.

LIMITATIONS OF SELLER'S LIABILITY

Multiquip shall not be liable here under for damages in excess of the purchase price of the item with respect to which damages are claimed, and in no event shall Multiquip be liable for loss of profit or good will or for any other special, consequential or incidental damages.

LIMITATION OF WARRANTIES

No warranties, express or implied, are made in connection with the sale of parts or trade accessories nor as to any engine not manufactured by Multiquip. Such warranties made in connection with the sale of new, complete units are made exclusively by a statement of warranty packaged with such units, and Multiquip neither assumes nor authorizes any person to assume for it any other obligation or liability whatever in connection with the sale of its products. A part from such written statement of warranty, there are no warranties, express, implied or statutory, which extend beyond the description of the products on the face hereof.

PARTS AND OPERATION MANUAL

HERE'S HOW TO GET HELP

*PLEASE HAVE THE MODEL AND SERIAL NUMBER
ON-HAND WHEN CALLING*

PARTS DEPARTMENT

800-427-1244 or 310-537-3700

FAX: 800-672-7877 or 310-637-3284

SERVICE DEPARTMENT/TECHNICAL ASSISTANCE

800-478-1244 or 310-537-3700

FAX: 310- 537-4259

WARRANTY DEPARTMENT

888-661-4279, or 310-661-4279

FAX: 310- 537-1173

MAIN

800-421-1244 or 310-537-3700

FAX: 310-537-3927



MULTIQUIP INC.

POST OFFICE BOX 6254
CARSON, CA 90749
310-537-3700 • 800-421-1244
FAX: 310-537-3927
E-MAIL: mq@multiquip.com
WWW: multiquip.com

Atlanta • Boise • Dallas • Houston • Newark
Quebec, Canada • Manchester, UK • Rio De Janeiro, BR • Guadalajara, MX