

OPERATION AND PARTS MANUAL



EC-92S EC-92P ESSICK SERIES CONCRETE MIXERS

Revision #7 (12/22/06)



MULTIQUIP INC.

18910 WILMINGTON AVE.
CARSON, CALIFORNIA 90746
310-537-3700
800-421-1244
FAX: 310-537-3927

E-mail: mq@multiquip.com • **www:** www.multiquip.com

Atlanta • Boise • Dallas • Houston • Newark
Montreal, Canada • Manchester, UK
Rio De Janeiro, Brazil • Guadalajara, Mexico

PARTS DEPARTMENT:

800-427-1244
FAX: 800-672-7877
SERVICE DEPARTMENT/TECHNICAL ASSISTANCE:
800-478-1244
FAX: 310-631-5032



WARNING



CALIFORNIA — Proposition 65 Warning

Engine exhaust and some of its constituents, and some dust created by power sanding, sawing, grinding, drilling and other construction activities contains chemicals known to the State of California to cause cancer, birth defects and other reproductive harm. Some examples of these chemicals are:

- Lead from lead-based paints.
- Crystalline silica from bricks.
- Cement and other masonry products.
- Arsenic and chromium from chemically treated lumber.

Your risk from these exposures varies, depending on how often you do this type of work. To reduce your exposure to these chemicals: **ALWAYS** work in a well ventilated area, and work with approved safety equipment, such as dust masks that are specially designed to filter out microscopic particles.

EC-92P/S CONCRETE MIXER — TABLE OF CONTENTS

MQ ESSICK EC-92P/S Concrete Mixers

| | |
|---|-------|
| Here's How To Get Help | 3 |
| Table Of Contents | 4 |
| Parts Ordering Procedures | 5 |
| Specifications | 6 |
| Dimensions (Mixer) | 7 |
| Safety Message Alert Symbols | 8 |
| Rules For Safe Operation | 9-10 |
| Operation and Safety Decals | 11 |
| General Information | 12 |
| Mixer Basic Components | 13 |
| Basic Engine Components | 14 |
| Handwheel Assembly | 15 |
| Towing Guidelines | 16 |
| Safety Chain Connection | 17 |
| Electric Motor | 18-19 |
| Pre-Inspection (Gasoline Engine) | 20 |
| Initial Start-up (Gasoline Engine) | 21 |
| Initial Start-up (Electric Motor) | 22 |
| Operation | 23 |
| Maintenance (Engine) | 24-25 |
| Maintenance (Mixer) | 26-28 |
| Troubleshooting (Engine) | 30 |
| Troubleshooting (Engine/Mixer) | 31 |
| Explanation Of Code In Remarks Column | 32 |
| Suggested Spare Parts | 33 |

Componet Drawings

| | |
|--|-------|
| Nameplate and Decals | 34-35 |
| Mixer Assembly (Steel Drum) | 36-37 |
| Mixer Assembly (Plastic Drum) | 38-39 |
| Main Frame Assembly | 40-41 |
| Axle Assembly | 42-43 |
| Cabinet Assembly | 44-45 |
| Gas Engine Mounting Plate Asassembly | 46-47 |
| Electric Motor Mounting Plate Asassembly | 48-49 |

HONDA GX240K1 HA2 ENGINE

| | |
|--------------------------------|-------|
| Air Cleaner Assembly | 50-51 |
| Camshaft Assembly | 52-53 |
| Carburetor Assembly | 54-55 |
| Control Assembly | 56-57 |
| Crankcase Cover Assembly | 58-59 |
| Crankshaft Assembly | 60-61 |
| Cylinder Barrel Assembly | 62-63 |
| Cylinder Head Assembly | 64-65 |
| Fan Cover Assembly | 66-67 |
| Flywheel Assembly | 68-69 |
| Muffler Assembly | 70-71 |
| Fuel Tank Assembly | 72-73 |
| Ignition Coil | 74-75 |
| Piston Assembly | 76-77 |
| Recoil Starter | 78-79 |
| Gear Reduction Assembly | 80-81 |
| Label Assembly | 82-83 |

| | |
|------------------------------------|----|
| Terms and Conditions of Sale | 84 |
|------------------------------------|----|

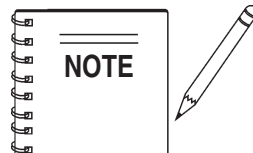

**Specification and part number
are subject to change without
notice.**

www.multiquip.com

**Ordering parts has never been easier!
Choose from three easy options:**



Order via Internet (Dealers Only):

Order parts on-line using Multiquip's SmartEquip website!

- View Parts Diagrams
- Order Parts
- Print Specification Information



If you have an MQ Account, to obtain a Username and Password, E-mail us at: parts@multiquip.com.

To obtain an MQ Account, contact your District Sales Manager for more information.

Goto www.multiquip.com and click on **Order Parts** to log in and save!

Use the **internet** and qualify for a **5% Discount** on *Standard orders* for all orders which include complete part numbers.*

Note: Discounts Are Subject To Change



Order via Fax (Dealers Only):

All customers are welcome to order parts via Fax.

Domestic (US) Customers dial:
1-800-6-PARTS-7 (800-672-7877)

Fax your order in and qualify for a **2% Discount** on *Standard orders* for all orders which include complete part numbers.*

Note: Discounts Are Subject To Change



Order via Phone: Domestic (US) Dealers Call:
1-800-427-1244

Non-Dealer Customers:

Contact your local Multiquip Dealer for parts or call 800-427-1244 for help in locating a dealer near you.



International Customers should contact their local Multiquip Representatives for Parts Ordering information.

When ordering parts, please supply:

- | | |
|---|--|
| <input type="checkbox"/> Dealer Account Number | <input type="checkbox"/> Specify Preferred Method of Shipment: |
| <input type="checkbox"/> Dealer Name and Address | <input checked="" type="checkbox"/> UPS/Fed Ex <input checked="" type="checkbox"/> DHL |
| <input type="checkbox"/> Shipping Address (if different than billing address) | <input type="checkbox"/> Priority One <input checked="" type="checkbox"/> Truck |
| <input type="checkbox"/> Return Fax Number | <input type="checkbox"/> Ground |
| <input type="checkbox"/> Applicable Model Number | <input type="checkbox"/> Next Day |
| <input type="checkbox"/> Quantity, Part Number and Description of Each Part | <input type="checkbox"/> Second/Third Day |

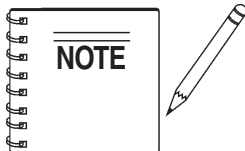

All orders are treated as *Standard Orders* and will ship the same day if received prior to 3PM PST.

WE ACCEPT ALL MAJOR CREDIT CARDS!



EC-92P/S CONCRETE MIXER — SPECIFICATIONS

Table 1. Specifications (Engines/Electric Motor)

| | Model | HONDA GX240K1HA2 | ROBIN EH-252YR000 | Baldor 35LYL229 |
|-----------------------|-----------------------|---|---|--|
| Engine/Electric Motor | Type | Air-cooled 4 stroke, Single Cylinder, OHV, Horizontal Shaft Gasoline Engine | Air-cooled 4 stroke, Single Cylinder, OHV, Horizontal Shaft Gasoline Engine | 1.5 HP, Single-phase 115/230 VAC, Electric Motor |
| | Bore X Stroke | 2.90 in. X 2.30 in. (73 mm x 58 mm) | 2.95 in. X 2.24 in. (75 mm x 57 mm) | N/A |
| | Displacement | 14.81 cc | 15.31 cc | N/A |
| | Max Output | 8.0 H.P./3600 R.P.M. | 8.5 H.P./4000 R.P.M. | 1.5 HP/1725 R.P.M. |
| | Fuel Tank Capacity | Approx. 1.59 U.S. Gallons (6 Liters) | Approx. 1.59 U.S. Gallons (6 Liters) | N/A |
| | Fuel | Unleaded Gasoline | Unleaded Gasoline | N/A |
| | Lube Oil Capacity | 2-1/3 pints | 2 pints | N/A |
| | Speed Control Method | Centrifugal Fly-weight Type | Centrifugal Fly-weight Type | N/A |
| | Starting Method | Recoil Start | Recoil Start | Electric |
| | Input Voltage | N/A | N/A | 115/230 VAC Single Phase |
| | Dimension (L x W x H) | 14.0 x 16.9 X 16.1 in. (355 X 430 X 410 mm) | 14.40 x 16.20 X 17.32 in. (366 X 412 X 440 mm) | 15.55 x 8.65 X 9.06 in. (395 X 220 X 230 mm) |
| Dry Net Weight | 55.1 lbs (25 Kg.) | 50.7 lbs (23 Kg.) | Approx. 12 lbs (5.4 kg.) | |

Table 2. EC-92P/S Specifications

| | |
|--|----------------------------|
| Height | 63 in. (1,600mm) |
| Width | 51 in. (1,295 mm) |
| Length | 86 in. (2,185 mm) |
| Maximum Drum Capacity | 12.35 cu. ft. (350 liters) |
| Maximum Mixing Capacity | 9.0 cu. ft. (255 liters) |
| Bag Capacity | 1 ~ 1.5 Bags |
| Weight - Without Engine/Electric Motor | 755 lbs. (342 Kg.) |

EC-92P/S CONCRETE MIXER — DIMENSIONS (MIXER)

See Table 2 for mixer dimensions

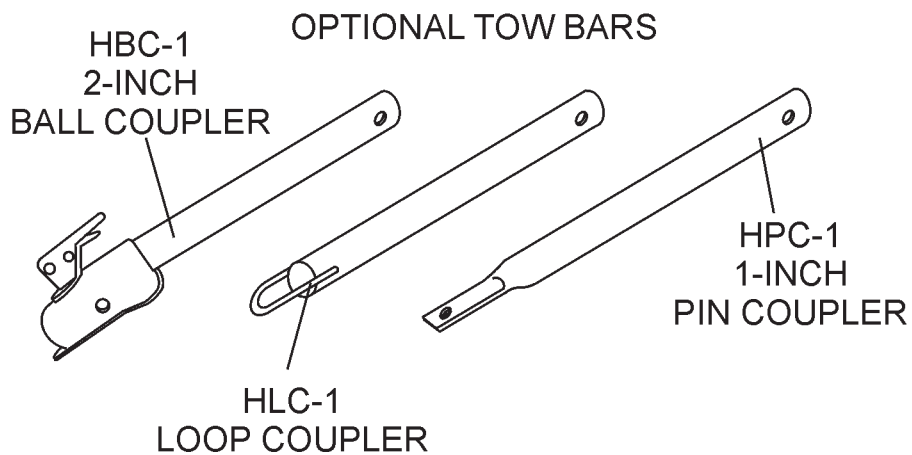
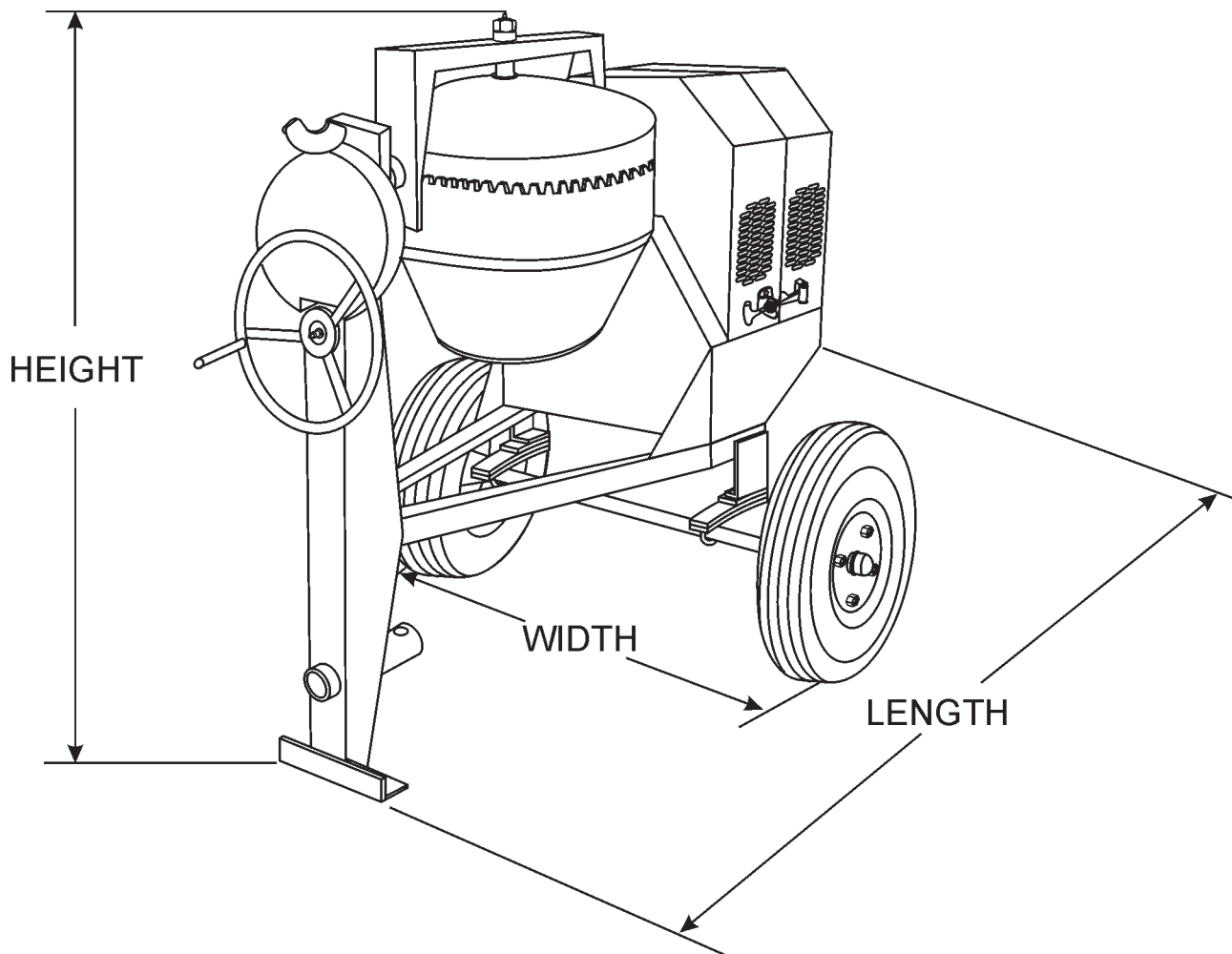
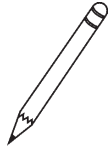
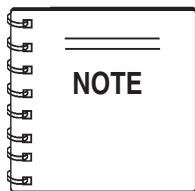

Figure 1. Mixer Dimensions

EC-92P/S CONCRETE MIXER — SAFETY MESSAGE ALERT SYMBOLS

FOR YOUR SAFETY AND THE SAFETY OF OTHERS!

Safety precautions should be followed at all times when operating this equipment. Failure to read and understand the Safety Messages and Operating Instructions could result in injury to yourself and others.



This Owner's Manual has been developed to provide complete instructions for the safe and efficient operation of the **MQ Essick Model EC-92P (Plastic) and EC-92S (Steel) Concrete Mixers.**

Before using these mixers, ensure that the operating individual has read and understands all instructions in this manual.

SAFETY MESSAGE ALERT SYMBOLS

The three (3) Safety Messages shown below will inform you about potential hazards that could injure you or others. The Safety Messages specifically address the level of exposure to the operator, and are preceded by one of three words: **DANGER**, **WARNING**, or **CAUTION**.



DANGER: You **WILL** be **KILLED** or **SERIOUSLY** injured if you do not follow directions.



WARNING: You **CAN** be **KILLED** or **SERIOUSLY** injured if you do not follow directions.



CAUTION: You **CAN** be injured if you do not follow directions.

Potential hazards associated with the MQ Essick EC-92P/EC-92S concrete mixers operation will be referenced with Hazard Symbols which appear throughout this manual, and will be referenced in conjunction with Safety Message Alert Symbols.

HAZARD SYMBOLS



Rotating Parts



NEVER operate equipment with covers, or guards removed. Keep fingers, hands, hair and clothing away from all moving parts to prevent injury.



Accidental Starting



OFF

ALWAYS place the circuit breaker or power ON/OFF switch in the **OFF** position when the pump is not in use.



Sight and Hearing hazard

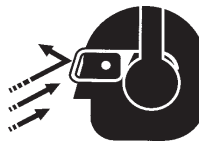

ALWAYS wear approved eye and hearing protection.



Respiratory Hazard



ALWAYS wear approved respiratory protection.



Equipment Damage Messages

Other important messages are provided throughout this manual to help prevent damage to your mixer, other property, or the surrounding environment.

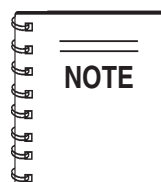

This mixer, other property, or the surrounding environment could be damaged if you do not follow instructions.

EC-92P/S CONCRETE MIXER — RULES FOR SAFE OPERATION

DANGER:



Failure to follow instructions in this manual may lead to serious injury or even death! This equipment is to be operated by trained and qualified personnel only! This equipment is for industrial use only.

The following safety guidelines should always be used when operating the **MQ Essick** EC-92P/EC-92S Concrete Mixers:

GENERAL SAFETY

- **DO NOT** operate or service this equipment before reading this entire manual.



- This equipment should not be operated by persons under 18 years of age.

- **NEVER** operate this equipment without proper protective clothing, shatterproof glasses, steel-toed boots and other protective devices required by the job.



- **NEVER** operate this equipment when not feeling well due to fatigue, illness or taking medicine.



- **NEVER** operate this equipment under the influence of drugs or alcohol.



- Whenever necessary, replace nameplate, operation and safety decals when they become difficult read.

- **ALWAYS** check the machine for loosened threads or bolts before starting.

- **ALWAYS** wear proper respiratory (mask) hearing and eye protection equipment when operating the mixer.



- **NEVER!** place hands inside the drum while the drum is rotating.

- **NEVER** touch the hot exhaust manifold, muffler or cylinder. Allow these parts to cool before servicing engine or mixer.



- **High Temperatures** – Allow the engine to cool before adding fuel or performing service and maintenance functions. Contact with *hot* components can cause serious burns.

- The engine of this mixer requires an adequate free flow of cooling air. **NEVER!** operate the mixer in any enclosed or narrow area where free flow of the air is restricted. If the air flow is restricted it will cause serious damage to the mixer or engine and may cause injury to people and property. Remember the mixer's engine (gasoline models only) gives off **DEADLY** gases.

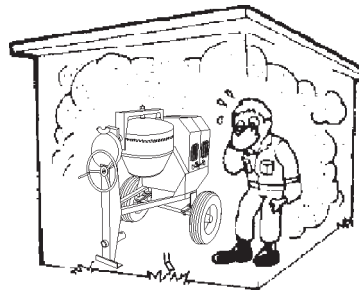

If the air flow is restricted it will cause serious damage to the mixer or engine and may cause injury to people and property. Remember the mixer's engine (gasoline models only) gives off **DEADLY** gases.

- **ALWAYS** refuel in a well-ventilated area, away from sparks and open flames.

- **ALWAYS** use extreme caution when working with **flammable** liquids. When refueling, **stop the** engine and allow it to cool. **DO NOT** smoke around or near the machine. Fire or explosion could result from fuel vapors, or if fuel is spilled on a hot engine.

- **NEVER** operate the mixer in an explosive atmosphere or near combustible materials. An explosion or fire could result causing severe **bodily harm or even death**.

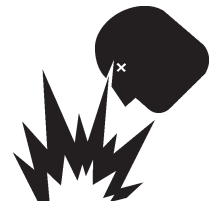

- Topping-off to filler port is dangerous, as it tends to spill fuel.

- Refer to the **Engine Owner's Manual** for engine technical questions or information.

- **NEVER** use accessories or attachments, which are not recommended by **MQ Essick** for this equipment. Damage to the equipment and/or injury to user may result.

- Manufacturer does not assume responsibility for any accident due to equipment modifications.

EC-92P/S CONCRETE MIXER — RULES FOR SAFE OPERATION

- **NEVER** run engine without air cleaner. Severe engine damage may occur.
- **ALWAYS** read, understand, and follow procedures in Operator's Manual before attempting to operate equipment.
- **ALWAYS** be sure the operator is familiar with proper safety precautions and operations techniques before using roller.
- **ALWAYS** store equipment properly when it is not being used. Equipment should be stored in a clean, dry location out of the reach of children.
- **NEVER** leave the mixer unattended, turn off engine or electric motor when unattended.
- **CAUTION** must always be observed while servicing this mixer. Rotating parts can cause injury if contacted.
- Unauthorized equipment modifications will void all warranties.
- Ensure that any extension cable is protected against damage and not liable to be tripped over or trapped underneath the mixer.
- **DO NOT** allow extension cord to come into contact with water or fluids.
- **DO NOT** spray water onto electric motor.
- This mixer is intended for the production of concrete. Mixer must be used only for its intended purpose.
- This mixer is not suitable for the mixing of **flammable** or **explosive** substances.
- **NEVER** operate the mixer in an **explosive** atmosphere.
- Before starting the mixer, check that all **guards** are in position and correctly fitted.
- Keep area around the mixer **clear of obstructions** which could cause persons to fall onto **moving parts**.
- **ALWAYS** ensure mixer is on level ground before mixing.
- Become familiar with the controls of the mixer before operating.
- **ALWAYS** replace any worn or damaged warning decals.
- Ensure the drum is **rotating** while filling and emptying the drum.
- **ALWAYS** disconnect AC power plug from power source before moving mixer (electric model only).
- **High Temperatures** – Always stop engine and allow the engine to cool before adding fuel, oil or performing service and maintenance functions. Contact with **hot** components can cause serious burns.

- **NEVER** disconnect any "**emergency or safety devices**". These devices are intended for operator safety. Disconnection of these devices can cause severe injury, bodily harm or even death! Disconnection of any of these devices will void all warranties.
- If mixer is equipped with an electric motor, operate electric motor only at the specified voltage indicated on the nameplate.
- Make sure the **OFF/ON** power switch on the electric motor is **always** in the **OFF** position before inserting the mixer's power plug into an AC receptacle (electric model only).

Maintenance Safety

- **NEVER** lubricate components or attempt service on a running machine.
- **ALWAYS** allow the machine a proper amount of time to cool before servicing.
- Keep the machinery in proper running condition.
- Fix damage to the machine immediately and always replace broken parts, or missing decals.
- Dispose of hazardous waste properly. Examples of potentially hazardous waste are used motor oil, fuel and fuel filters.
- **DO NOT** use food or plastic containers to dispose of hazardous waste.
- **DO NOT** pour waste, oil or fuel directly onto the ground, down a drain or into any water source.

Emergencies

- **ALWAYS** know the location of the nearest **fire extinguisher** and **first aid kit**.



- In emergencies **always** know the location of the nearest phone or **keep a phone on the job site**. Also know the phone numbers of the nearest **ambulance**, **doctor** and **fire department**. This information will be invaluable in the case of an emergency.



EC-92P/S CONCRETE MIXER — OPERATION AND SAFETY DECALS

Machine Safety Decals

The MQ Eccick EC-92P and EC-92S mixers are equipped with a number of safety decals (Figure 1A). These decals are provided for operator safety and maintenance information. The illustration below and on the next page shows these decals as they appear on the machine. Should any of these decals become unreadable, replacements can be obtained from your dealer.



P/N: 13118



CONTACT
MQ PARTS DEPT.



P/N: DCL151



P/N: CIPDCL160



P/N: EM510891



P/N: EM948630

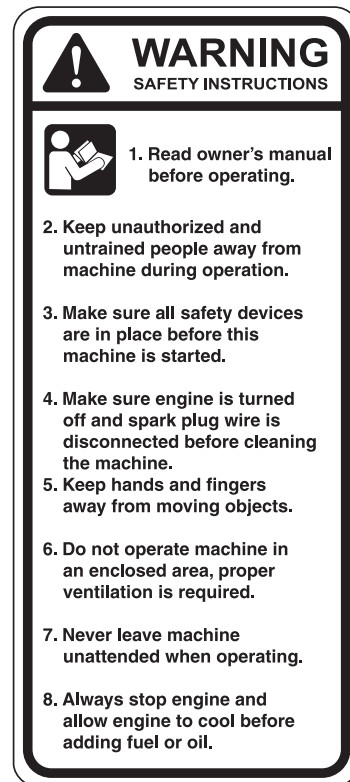

P/N: 504713

Figure 1A. EC-92P/S Mixer Decals

EC-92P/S CONCRETE MIXER — GENERAL INFORMATION

Application

This mixer is **only** intended for the production of **concrete**. The mixer must be used for its intended purpose and is not suitable for the mixing of **flammable** or **explosive** substances. The mixer **must not be used** in an explosive atmosphere. Use Table 4 (Mixing Hints) as a guide when mixing concrete for various applications.

Power Plants

The MQ Essick EC-92P and EC-92S mixers can be powered by a variety of power plants or an electric motor. Refer to Table 2 to for specific engine or electric motor data information. All engines are air-cooled, 4-stroke gasoline engines.

Electrical

If mixer is equipped with an **electric motor**, make sure that the power being supplied to the motor corresponds to the voltage rating label on the motor. Supplying the wrong voltage to the electric motor will cause severe electrical damage to the motor.

Always make sure the **OFF/ON** switch on the electric motor is in the **OFF** position before applying power.

It is **strongly recommended** when inserting the mixer's power cord into a receptacle, that a G.F.C.I. (**Ground Fault Current Interrupter**) receptacle be used (115 VAC applications).

Extension Cables

The extension cable should be a 3-wire configuration that includes a ground wire that conforms to UL code. The wire cross section must be a minimum of 2.5 mm². Choose an extension cord of adequate current carrying as Referenced in Table 6. Remember **distance** affects the wire size of the extension cable.

Ensure that the extension cable is carefully laid out avoiding **wet areas**, **sharp edges** and locations where vehicles might run over it. Avoid allowing the extension cable to be trapped underneath the mixer.

Unroll the extension cable fully or it will overheat and could catch fire. Make sure that all extension cable connections are dry and safe. Replace any defective or badly worn extension cable immediately.

Hardware

Check all hardware on the mixer before starting. Periodically inspect all hardware. Loose hardware can contribute to early component failure and poor performance. Use Table 3 as general guideline when the torqueing of mixer hardware is required. Remember to keep all mixer hardware components tight.

Table 3. Hardware Torque Recommendations

| Hardware Diameter | Torque (ft-lbs) |
|-------------------------|-----------------|
| 5/16-inch x 18 | 14 |
| 3/8-inch x 16 | 24 |
| 3/8-inch x 24 | 37 |
| 1/2-inch x 13 | 39 |
| 1/2-inch x 13 (Grade 8) | 90 |

Engine Maintenance

For basic engine maintenance, refer to the engine maintenance section in this manual. For a more detailed engine maintenance, refer to the **Honda** or **Robin** Engine Owner's manual furnished with the engine.

Table 4. MIXING HINTS

| APPLICATIONS | MIX RATIOS | BATCH QUANTITIES | | | | | APPROX. BATCH OUTPUT | |
|--------------------------------------|------------|-------------------------------|---------|-----|---------|-----|----------------------|-----|
| | | CEMENT 112 lbs. (50 Kgs.) Bag | SAND | | STONE | | | |
| | | | CU. FT. | LTR | CU. FT. | LTR | CU. FT. | LTR |
| Most Ordinary | 1:2:4 | 1/2 BAG | 1-1/4 | 35 | 2-1/2 | 71 | 3 | 85 |
| Foundations | 1:3:6 | 1/3 BAG | 1-1/4 | 35 | 2-1/2 | 71 | 2-3/4 | 78 |
| Rough Mass Concrete | 1:4:8 | 1/4 BAG | 1-1/4 | 35 | 2-1/2 | 71 | 2-3/4 | 78 |
| Watertight Floors, Tanks, Pits, Etc. | 1:1-1/2:3 | 2/3 BAG | 1-1/4 | 35 | 3 | 71 | 3 | 85 |

EC-92P/S CONCRETE MIXER — MIXER BASIC COMPONENTS

Figure 2. Mixer Major Components

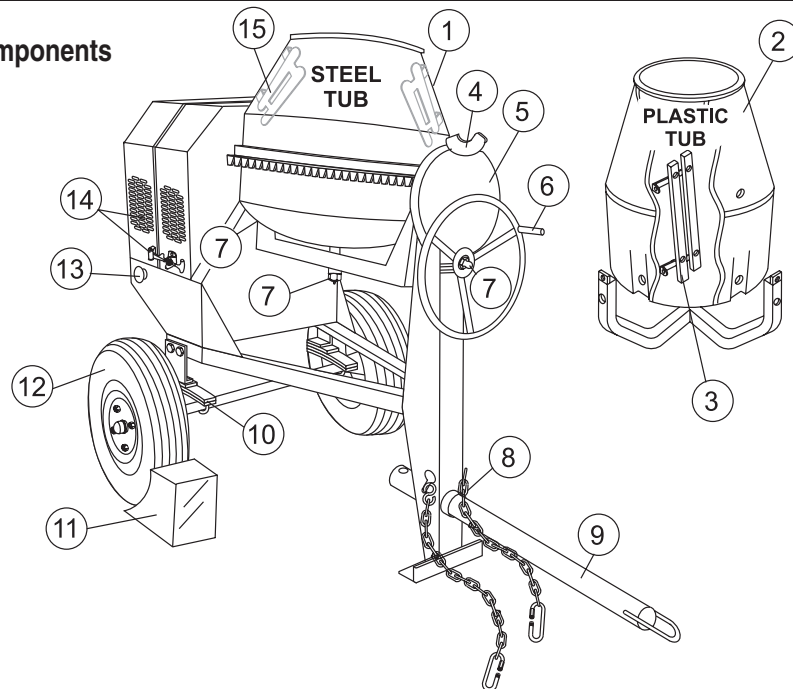

1. **Steel Mixing Drum** — The EC-92S uses a 9 cu. ft steel mixing drum. This drum is to be used for mixing of concrete. Always clean the drum after each use. **DO NOT** use this mixing drum for the mixing of volatile liquids.
2. **Plastic Mixing Drum** — The EC-92P uses a 6 cu. ft plastic mixing drum. This drum is to be used for mixing of concrete. Always clean the drum after each use. **DO NOT** use this mixing drum for the mixing of **volatile liquids**.
3. **Mixing Blades (Plastic)** — Used for the mixing concrete. Replace blades when they show signs of wear. Reference plastic mixing drum in the parts section of this manual.
4. **Dump Latch** — To rotate the mixing drum, this latch must be in the up position. To lock the drum, place the latch in the down position.
5. **Dump Gear Guard** — **NEVER** operate the mixer with this guard removed. Its purpose is to prevent dirt and debris from entering the dump gear. In addition operator clothing could become entangled in the dump gear, causing severe injury and bodily harm.
6. **Handwheel** — Turn this wheel clockwise or counter-clockwise to rotate the mixing drum. Remember the dump latch must be in the **up position** in order for the mixing drum to be rotated.
7. **Zerk Fittings** — There is, at the bottom and engine side of the **yoke**, and center of the **handwheel** grease zerk fittings. Lubricate these fittings as referenced in the maintenance section of this manual.
8. **Safety Chain** — This mixer uses a 3/16-inch thick, 72-inches long zinc-plated safety chain. **ALWAYS** connect the safety chain when towing.
9. **Tow Bar** — This mixer uses various towing bars, please reference the frame assembly drawing and parts list in this manual to determine which tow bar meets your requirements.
10. **Leaf Suspension** — This mixer uses a leaf type suspension. Check the mounting hardware for bolt hole elongation and tightness. See maintenance section of this manual for recommended maintenance.
11. **Chock Blocks** — Place these blocks (not included as part of the mixer package) under each mixer wheel to prevent rolling, when mixer is not connect to the towing vehicle.
12. **Tires Ply** — The tire ply (layers) number is rated in letters; This mixer uses 13-inch 2-ply tires. Replace with only recommended type tires.
13. **ON/OFF Switch (gasoline only)** — This switch is provided on *mixers with gasoline* engines only and is located on the side of the mixer frame. When activated it will shut down the engine. Pull out when starting the engine.
14. **Cabinet/Latch** — Encloses engine and electric motor. **NEVER** run mixer with cabinet removed. Use latches to secure engine compartment cabinet.
15. **Mixing Blades (Steel)** — Used for the mixing of concrete. When blades show signs of wear, entire steel mixing drum assembly must be replaced. See steel mixing drum assembly in the parts section of this manual.

EC-92P/S CONCRETE MIXER — BASIC ENGINE COMPONENTS

Honda GX Series Engine Shown

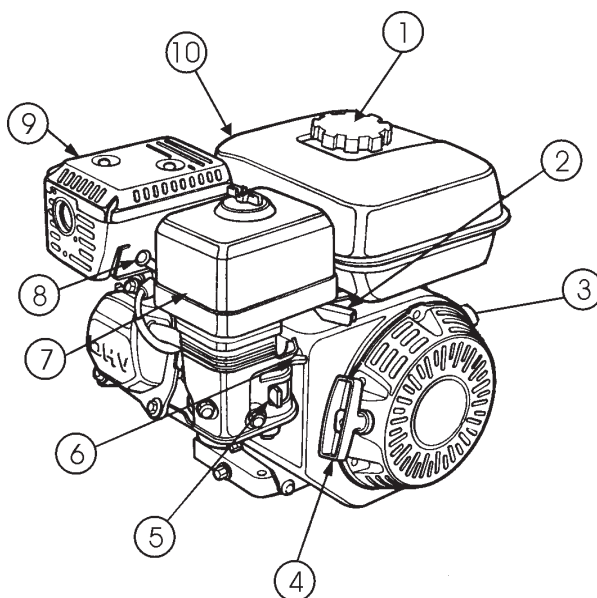

Figure 3. Engine Controls and Components

INITIAL SERVICING

The engine (Figure 3) must be checked for proper lubrication and filled with fuel prior to operation. Refer to the manufacturers Engine manual for instructions & details of operation and servicing.

1. **Fuel Filler Cap** – Remove this cap to add unleaded gasoline to the fuel tank. Make sure cap is tightened securely. **DO NOT** over fill.



WARNING

Adding fuel to the tank should be accomplished only when the engine is stopped and has had an opportunity to cool down. In the event of a fuel spill,

DO NOT attempt to start the engine until the fuel residue has been completely wiped up, and the area surrounding the engine is dry.

2. **Throttle Lever** – Used to adjust engine RPM speed (lever advanced forward **SLOW**, lever back toward operator **FAST**).
3. **Engine ON/OFF Switch** – ON position permits engine starting, OFF position stops engine operations.
4. **Recoil Starter (pull rope)** – Manual-starting method. Pull the starter grip until resistance is felt, then pull briskly and smoothly.

5. **Fuel Valve Lever** – **OPEN** to let fuel flow, **CLOSE** to stop the flow of fuel.
6. **Choke Lever** – Used in the starting of a cold engine, or in cold weather conditions. The choke enriches the fuel mixture.
7. **Air Cleaner** – Prevents dirt and other debris from entering the fuel system. Remove wing-nut on top of air filter cannister to gain access to filter element.

NOTE

Operating the engine without an air filter, with a damaged air filter, or a filter in need of replacement will allow dirt to enter the engine, causing rapid engine wear.

8. **Spark Plug** – Provides spark to the ignition system. Set spark plug gap to 0.6 - 0.7 mm (0.028 - 0.031 inch). Clean spark plug once a week.
9. **Muffler** – Used to reduce noise and emissions.



WARNING

Engine components can generate extreme heat. To prevent burns, **DO NOT** touch these areas while the engine is running or immediately after operating. **NEVER** operate the engine with the muffler removed.

10. **Fuel Tank** – Holds unleaded gasoline. For additional information refer to engine owner's manual.

EC-92P/S CONCRETE MIXER — HANDWHEEL ASSEMBLY

Assembly

The EC-92P and EC-92S concrete mixers are shipped with the handwheel detached. Attach the handwheel to the mixer as shown in Figure 4.

STEP 1.
CUT TY-BAND SECURING
DUMP LATCH AND HANDWHEEL.

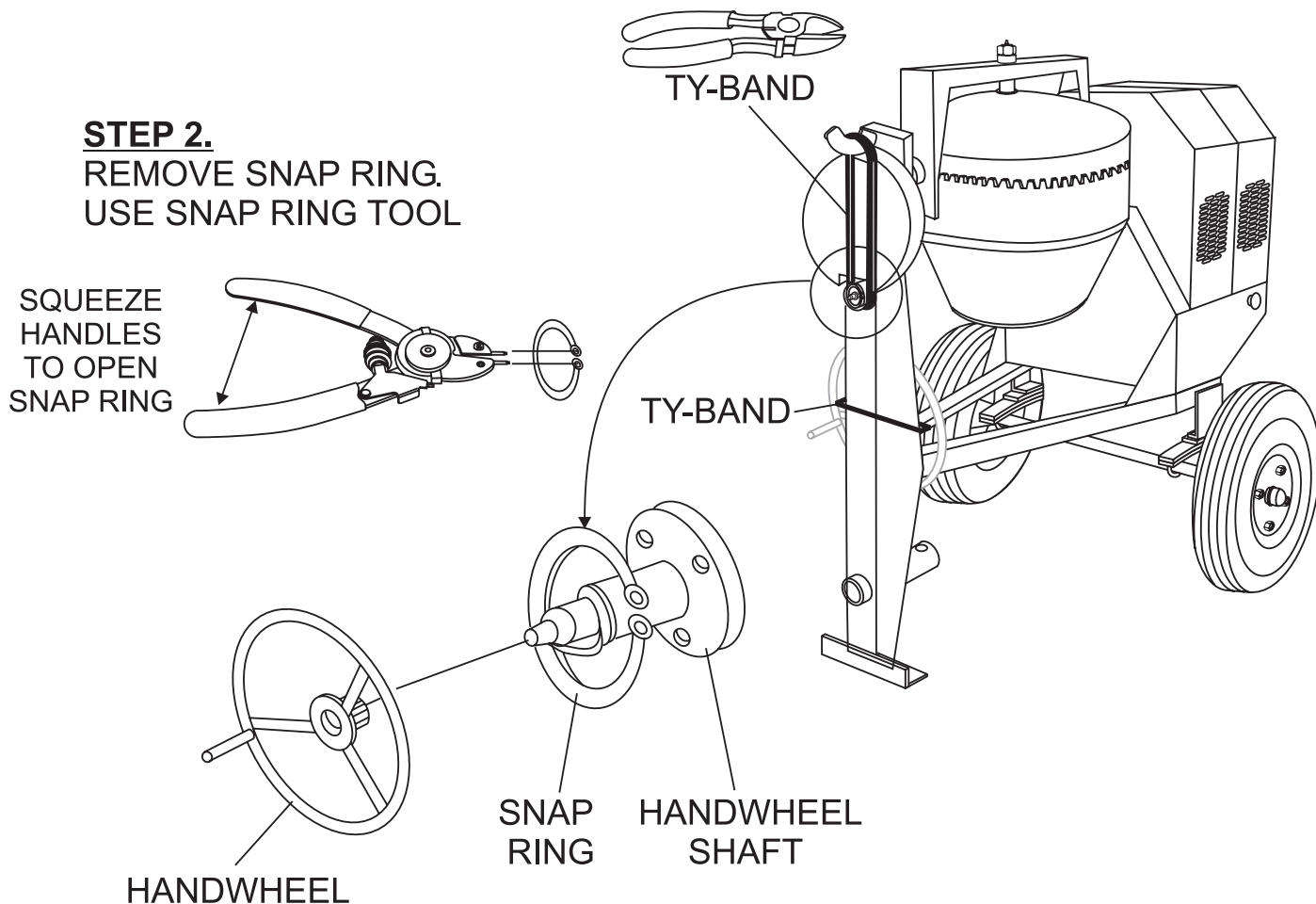

STEP 3.
PLACE HANDWHEEL
ONTO HANDWHEEL-
SHAFT.

STEP 4.
RE-INSTALL SNAP
RING BACK ONTO
HANDWHEEL SHAFT.

Figure 4. Handwheel Assembly

EC-92P/S CONCRETE MIXER — TOWING GUIDELINES

Towing Safety Precautions

CAUTION:



- Check with your county or state safety towing regulations department before towing your *mixer*.

To reduce the possibility of an accident while transporting the mixer on public roads, always make sure that the mixer towing components and the towing vehicle are in good operating condition and both units are mechanically sound.

The following list of suggestions should be used when towing the mixer:

- Make sure that the hitch and coupling of the towing vehicle are rated equal to, or greater than the trailer "gross vehicle weight rating" (GVWR).
- **ALWAYS** inspect the hitch and coupling for wear. **NEVER** tow the mixer with defective hitches, couplings, chains etc.
- **CHECK** the tire air pressure on both the towing vehicle and the trailer. Also check the tire tread wear on both vehicles.
- **ALWAYS** make sure the mixer is equipped with a "**Safety Chain**".
- **ALWAYS** attach trailer's safety chain to the frame of towing vehicle.
- **ALWAYS** make sure that the towing vehicle's directional, backup, and brake lights are working properly.
- Remember in most cases the maximum speed unless otherwise posted for highway towing is 45 MPH, however before towing your mixer, check your local state, and county vehicle towing requirements. Recommended off-road towing is not to exceed **10 MPH** or less depending on type of terrain.
- Place *chocked blocks* underneath wheels to prevent **rolling**, while parked, if disconnected from towing vehicle.
- Inflate tires to correct pressure, inspect tires for cuts, and excessive wear. See Table 16 (Tire Wear Troubleshooting).
- When towing of the mixer is required, place the drum in the up position (mouth facing upwards).
- **ALWAYS** make sure that the fuel valve lever is in the **OFF** position (gasoline models only).

- Check wheel mounting lug nuts with a **torque wrench**. Torque wheel lug nuts as described in the maintenance section of this manual.
- Check tightness of U-clamp nuts, torque suspension hardware as referenced in the maintenance section of this manual.
- Avoid sudden stops and starts. This can cause skidding, or jackknifing. Smooth, gradual starts and stops will improve gas mileage.
- Avoid sharp turns to prevent rolling.

CAUTION:

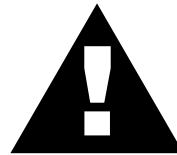

If the mixer tow bar is deformed or damaged replace entire tow bar. **NEVER** tow the mixer with a defective tow bar. There exist the possibility of the trailer separating from the towing vehicle.

Tow Bar to Vehicle Connection (Coupler Only)

1. Check the vehicle hitch ball, and mixer's coupler for signs of wear or damage. Replace any parts that are worn or damaged before towing.
2. Use only a 2-inch ball diameter (towing vehicle), this will match the mixer's 2-inch coupler. Use of any other ball diameter will create an extremely dangerous condition which can result in separation of the coupler and ball or ball failure.
3. After tow bar has been connected to mixer (see next page), attach mixer's coupler to the hitch ball on the towing vehicle securely and make sure the lock lever is in the down position (locked).

Mixer Tow Bar Vehicle Connection (Pintle and Loop)

1. Make sure the bumper on the towing vehicle is equipped to handle either a pintle or loop type tow bar configuration.
2. After tow bar has been connected to mixer (see next page), secure either type of tow bar to the towing vehicle, following state and county towing regulations.
3. As a minimum, use a 1/2-inch bolt and nylock nut grade 5 when securing either tow bar to the towing vehicle,

EC-92P/S CONCRETE MIXER — SAFETY CHAIN CONNECTION

CAUTION:



NEVER! tow the mixer with the safety chain removed. The safety chain is intended to prevent complete separation of the mixer from the towing vehicle in the event of a tow bar failure.

Reference Figure 5 for the installation of the **Safety Chain**.

Tow Bar to Mixer Connection

1. Insert the tow bar through the round opening at the bottom of the mixer stand.
Align the hole on the tow bar with the hole on the mixer frame, and insert 1/2-inch bolt through tow bar and frame. Secure tow bar to frame with 1/2-inch nylock nut. Tighten to 40 ft.-lbs.

2. Route the safety chain through the holes just above the tow bar, located on each side of the mixer stand.
Loop the chain together and place under the tow bar. Secure the loop with the connector link.
3. Extend the safety chain along the length of the tow bar, looping it through the tow bar's connector link. Remove any excess chain slack.
4. Connect the free end of (connector link) the safety chain to the towing vehicle. ***Remember it is critical that the length of the chain be properly adjusted,*** to prevent the **draw bar** and the front of the mixer stand from dropping to the the ground (contact) in the event the draw bar becomes disconnected from the towing vehicle.

Figure 5. Tow Bar and Safety Chain Installation

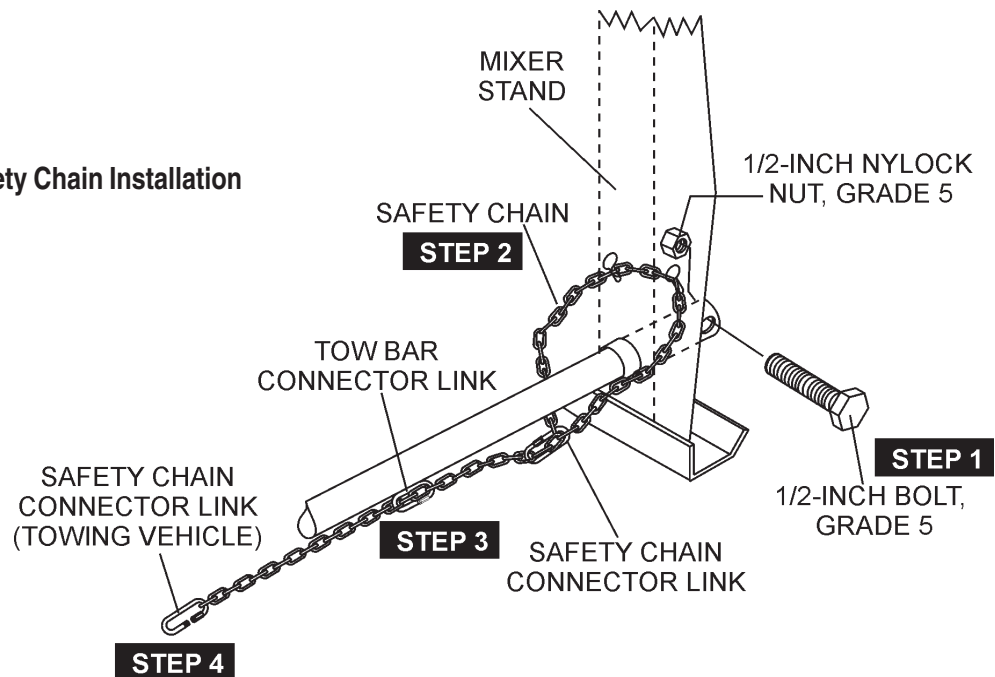

OPTIONAL TOW BARS

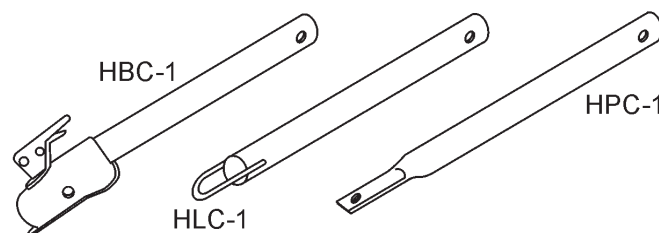

EC-92P/S CONCRETE MIXER — ELECTRIC MOTOR

Electric Motor

For maintenance care and operation of the electric motor, refer to your electric motor instruction booklet furnished with the electric motor.

Protect the electric motor from dust as much as possible and keep ventilating openings clean.

CAUTION:



- **DO NOT** spray water at any time on the **electric motor**.
- **DO NOT** operate electric motor in a explosive environment.

The electric motor used in this mixer is a single-phase 1.5 HP motor. The input voltage requirement for this motor is either 115 or 230 VAC only.

Electric Motor Connection

A 12 inch electrical cable (Figure 2) with a pigtail at one end is provided with the electrical motor for hookup to a power source. Table 1. shows the required NEMA connector for the desired motor horsepower rating. In addition, Table 2 also shows the matching NEMA approved connector for the required extension cord.

ALWAYS, make certain that the power source required for the electric motor is **correct** and always use the correct NEMA configuration plug. **Failure** to supply the correct voltage to the motor can severely damage the motor.

The electric motor supplied with the mixer is configured from the factory for 115 VAC grounded operation. Make certain that the correct size grounded (3-wires) extension cord is used. See Table 5.

Motors can burn out when the line voltage falls 10% below the voltage rating of the motor. Failure to use proper voltage will cause the motor to overheat and actuate the overload switch.

If overload protection should actuate because of improper voltage or any other malfunction, turn the main switch on the motor to the "OFF" position and correct the problem, press the reset switch button, and turn the main switch to the "ON" position.

Table 5. Recommended Extension Cord Sizes

| Electric Motor | Input Voltage | 50 ft. (15.24 m) | 75 ft. (22.86 m) | 100 ft. (30.48 m) | 200 ft. (60.96 m) |
|----------------|---------------|------------------|------------------|-------------------|-------------------|
| 1.5 HP | 115 VAC | No. 12 | No. 10 | No. 8 | No. 6 |
| | 230 VAC | No. 14 | No. 12 | No. 12 | No. 8 |

Electric Motor Voltage Change Switch

1. **ALWAYS** make certain the electric motor's **ON/OFF** switch is in the "OFF" position and the power cord has been disconnected from the power source.
2. Remove the voltage change lock-out bolt and nut (Figure 6). Change the position of the **voltage change toggle switch** from 115 VAC to 230 VAC. The mixer is factory wired for 115 VAC operation.
3. Re-install the voltage change lock-out bolt and nut.

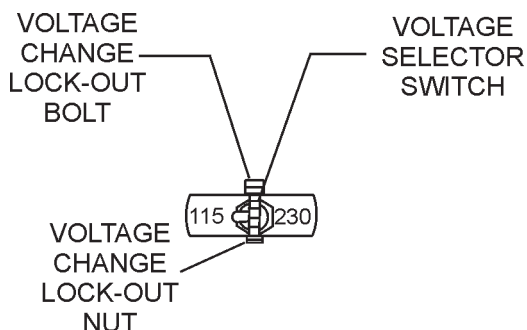
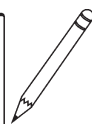
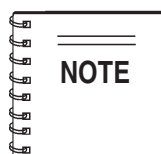

Figure 6. Voltage Change Switch

4. **Important!**, when changing the input voltage to the electric motor from 115 to 230 VAC, the **plug** on the electric motor power cord must also be changed. See Table 6 and Figure 7.

Table 6. Electric Motor Wiring Information

| Motor Horsepower Rating | 115-230 VAC - Single Phase | |
|-------------------------|----------------------------|----------------------------------|
| | NEMA Plug Connector | Mating NEMA Receptacle Connector |
| 1.5 HP (115 VAC) | L5-20P P/N EM940537 | L5-20R P/N EM940538 |
| 1.5 HP (230 VAC) | L6-20P P/N 940539 | L6-20R P/N 940540 |



NEVER! disable or disconnect the **ON/OFF** switch on the electric motor. It is provided for operator safety. Injury may result if it is disable, disconnected or improperly maintained.

EC-92P/S CONCRETE MIXER — ELECTRIC MOTOR

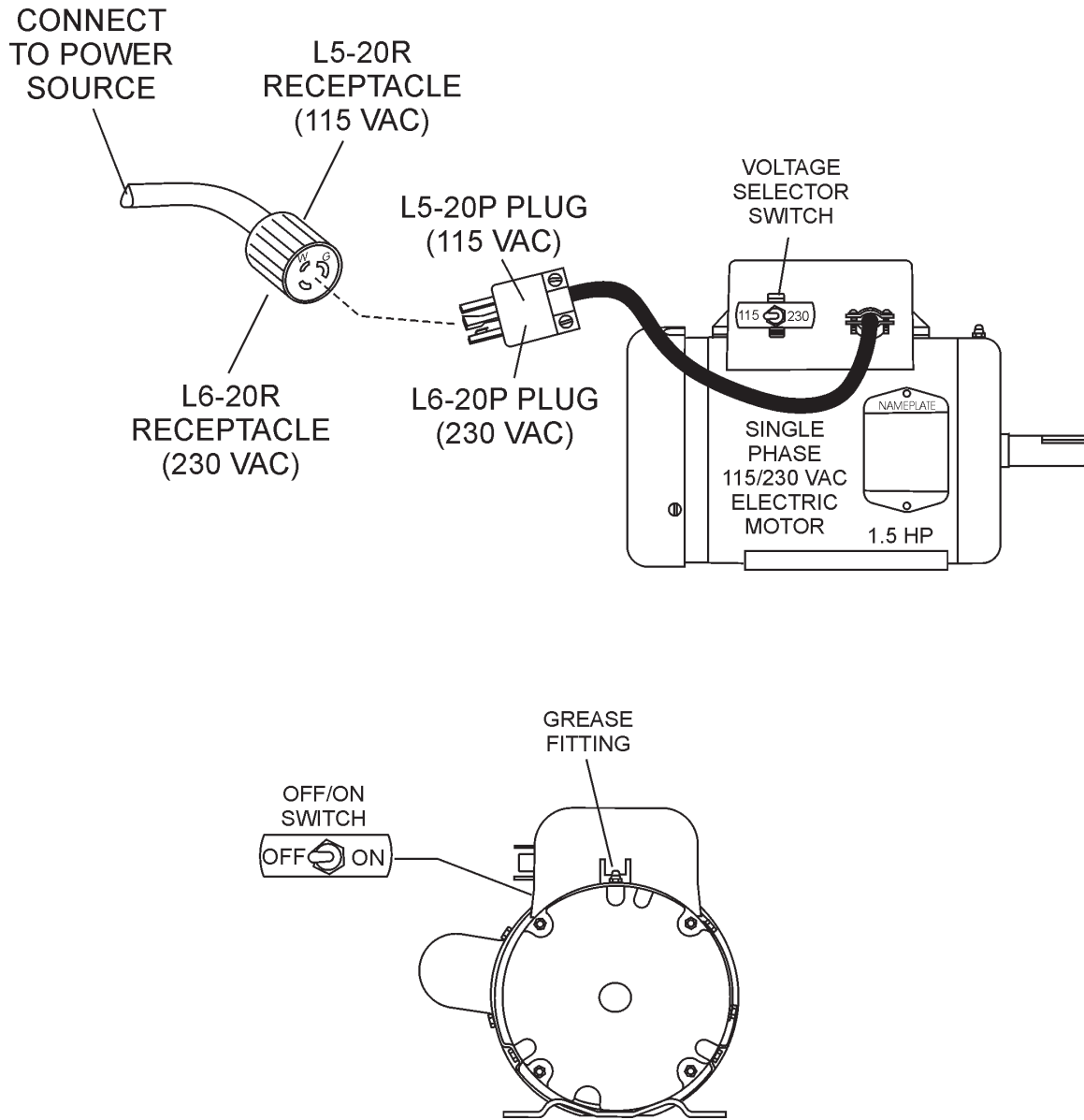

Figure 7. Single Phase Electric Motor with 12 inch Pigtail Cable

EC-92P/S CONCRETE MIXER — PRE-INSPECTION (GAS ENGINE)

Before Starting

1. Read safety instructions at the beginning of manual.
2. Clean the **mixer**, removing dirt and dust, particularly the engine cooling air inlet, carburetor and air cleaner.
3. Check the air filter for dirt and dust. If air filter is dirty, replace air filter with a new one as required.
4. Check carburetor for external dirt and dust. Clean with dry compressed air.
5. Check fastening nuts and bolts for tightness.

Engine Oil Check



1. To check the engine oil level, place the mixer on secure level ground with the engine stopped.
2. Remove the filler dipstick from the engine oil filler hole (Figure 8) and wipe it clean.

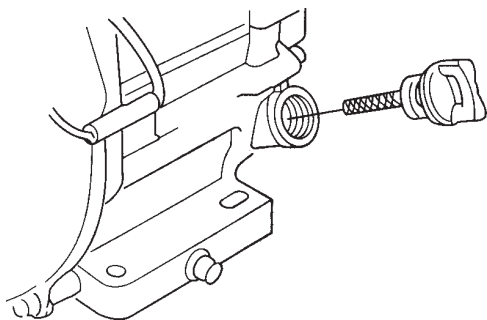

Figure 8. Engine Oil Dipstick (Removal)

3. Insert and remove the dipstick without screwing it into the filler neck. Check the oil level shown on the dipstick.
4. If the engine oil level is low (Figure 9), fill to the edge of the oil filler hole with the recommended oil type (Table 7). See Table 2 for the oil capacity of your type engine.

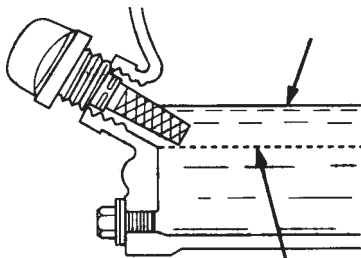

Figure 9. Engine Oil Dipstick (Oil Level)

Table 7. Oil Type

| Season | Temperature | Oil Type |
|-------------|----------------|---------------|
| Summer | 25°C or Higher | SAE 10W-30 |
| Spring/Fall | 25°C~10°C | SAE 10W-30/20 |
| Winter | 0°C or Lower | SAE 10W-10 |



Fuel Check

If your mixer has a gasoline engine, determine if the engine fuel is low. If fuel is low, remove the fuel filler cap and fill with **unleaded** gasoline. Motor fuels are highly flammable and can be dangerous if mishandled. **DO NOT** smoke while refueling. **DO NOT** attempt to refuel the trowel if the engine is **hot!** or **running**.

1. Remove the gasoline cap located on top of fuel tank.
2. Visually inspect to see if fuel level is low. If fuel is low, replenish with unleaded fuel.
3. When refueling, be sure to use a strainer for filtration. **DO NOT** top-off fuel. Wipe up any spilled fuel.

V-belt Check

A worn or damaged V-belt can adversely affect the performance of the mixer. If a V-belt is defective or worn simply replace the V-belt as outlined in the maintenance section of this manual.

Blade Check

Check for worn blades. If using a steel tub and the blades are worn, replace the entire tub assembly. Remember the blades are welded to tub.

If using a plastic tub, replace the blades using the part numbers referenced in the parts section of this manual.

Start/Stop Switches

This mixer has been equipped with a start/stop switches for both the gasoline and electric motor mixers. These switches should be tested every time the engine or motor is started.

Grease Fittings (Zerk)

Check the zerk grease fittings (Figure 27) as shown in the maintenance section of this manual. These grease fittings lubricate the **handwheel** and the **yoke mechanism**.

EC-92P/S CONCRETE MIXER — INITIAL START-UP (GAS ENGINE)

Starting the Engine (Gasoline Only)

The following steps outline the procedure for starting the engine. Depending on the type of engine employed in the mixer the steps may vary slightly. If your mixer has an electric motor disregard this section.

1. Move the fuel shut-off lever (Figure 10) to the **ON** position.

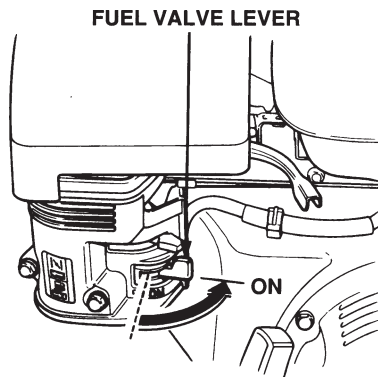

Figure 10. Fuel Shut-OFF Lever

2. To start a cold engine, move the choke lever (Figure 11) to the **CLOSED** position.

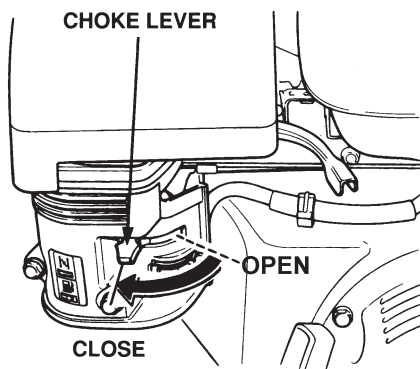

Figure 11. Choke Lever

3. Move the throttle lever (Figure 12) away from the slow position, about 1/3 of the way toward the fast position.

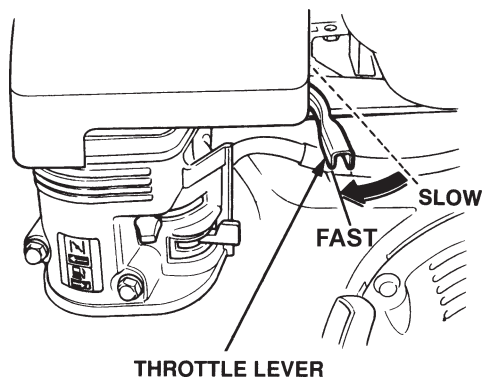

Figure 12. Throttle Lever

4. Turn the engine switch (Figure 13) to the **ON** position.

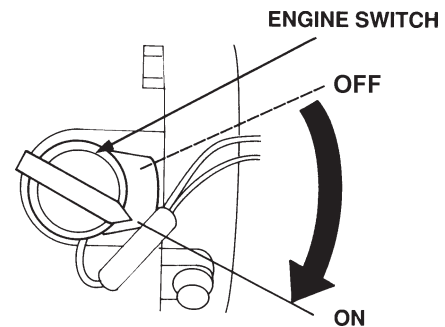

Figure 13. Engine ON/OFF Switch

5. Located at the rear of the mixer frame is the main **start/stop** button (Figure 14). Pull this button outward to start the engine.

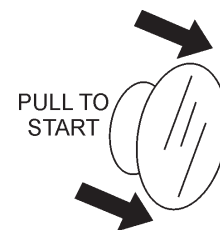

Figure 14. Engine Start/Stop Button

6. Pull the **starter grip** (Figure 15) lightly until you feel resistance, then pull briskly. The drum should be rotating at this time.

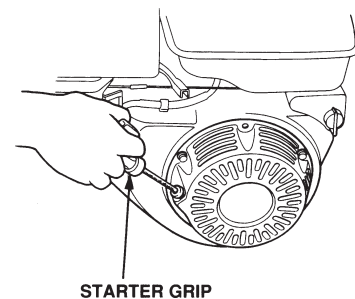

Figure 15. Starter Grip

EC-92P/S CONCRETE MIXER — INITIAL START-UP (ELECTRIC MOTOR)

Initial Start-up Instructions (Electric Motor)

Starting

CAUTION:



DO NOT attempt to operate the mixer until the Safety, General Information and Inspection sections have been read and understood.

1. Before starting, make sure mixer is positioned on a secure flat surface to prevent rolling.
2. Use an extension cord (see Table 5) of adequate current carrying capacity, insert the electric motor's power plug into one end of the extension cord.
3. **NEVER!** use a **worn** or **frayed** extension cord.
4. **NEVER!** operate mixer with V-belt cover removed.

DANGER



NEVER! touch the power cord (Figure 16) with **wet hands** or while **standing in water** when it is connected to a power source. The possibly exists of electrical shock (electrocution) even death. **NEVER!** spray water directly on the electric motor.

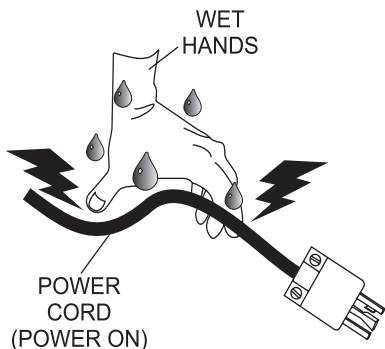
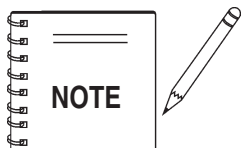

Figure 16. Extension Cord (Wet Hands)



To prevent personnel from tripping over the extension cord, position the extension cord so that it lays flat and is not curled underneath the mixer.

5. Place the voltage selector switch (Figure 17) in the position that is in accordance with voltage listed on the electric motor's nameplate. The electric motor's are shipped from the factory with the with the voltage selector switch placed in the 115 VAC position.

If 230 VAC is required, remove the locking bolt and nut and flip the voltage selector toggle switch to the 230 VAC position. Reinstall the locking bolt and nut to prevent the toggle switch from being accidentally tripped.

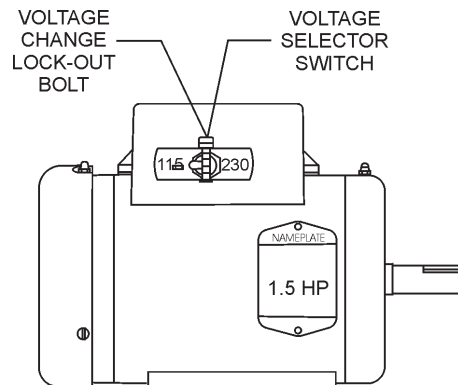

Figure 17. Voltage Change Switch (115 VAC Position)

6. Plug the other end of the extension cord into either a 115 or 230 VAC power source (look at position of voltage selector switch). Remember to read the nameplate to determine the motor's input voltage requirement.

WARNING:



ALWAYS read the label on the electric motor before applying power. The label will indicate the correct power requirements for the motor. Remember the use of an incorrect input voltage will severely damage the electric motor.

Starting the Electric Motor

1. Set the electric motor's **ON/OFF** switch (Figure 18) to the **ON** position.

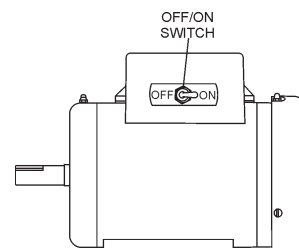

Figure 18. Electric Motor ON/OFF Switch (ON Position)

EC-92P/S CONCRETE MIXER — OPERATION

Operation

1. To position the tub, make sure the mixer is placed on firm level ground, then **pull up** on the **dump latch** (Figure 19) and turn the **hand wheel** until the tub is at the desired position. Once the tub is at the desired position, **pull down** on the dump latch to lock the tub in position.

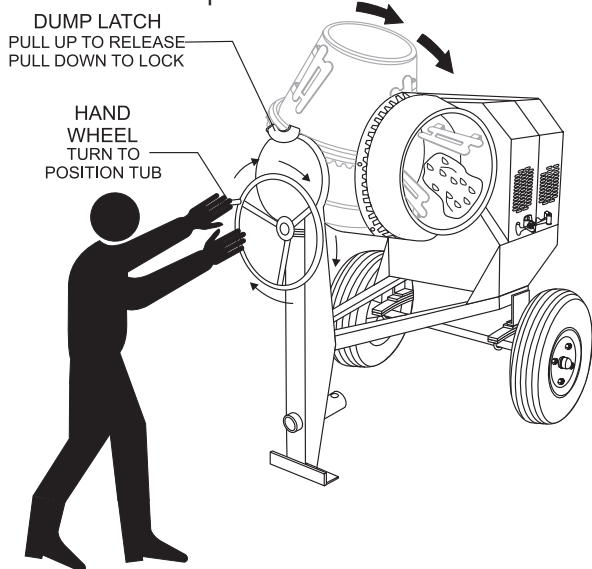

Figure 19. Mixing Drum Positioning

CAUTION:



NEVER stand in front or behind the mixing drum while it is being placed in the dump position. Stay clear of the mixing drum while it is being positioned.

2. As the drum rotates, use a shovel (Figure 20) to place the cement mix inside the drum, add water as required. Be careful to only place the **tip** of the shovel inside the drum.

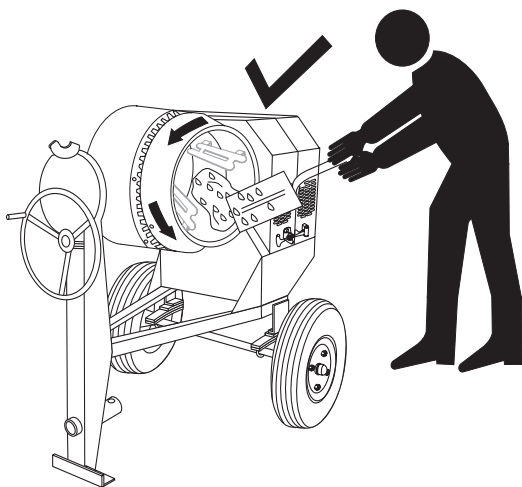
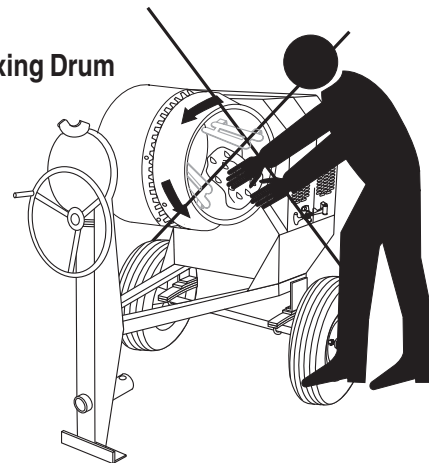

Figure 20. Filling Mixing Drum

3. Placing the shovel all the way inside the drum (Figure 21) will cause the shovel to strike the blades. This condition will make the shovel rotate, and could cause injury to personnel. **NEVER** place hands inside the mixing drum while it is rotating.

Figure 21. Filling Mixing Drum



Stopping the Mixer (Gasoline)

1. Push the main **start/stop** switch (Figure 22) inward to stop the engine.

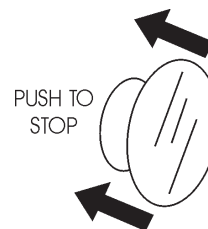

Figure 22. Start/Stop Button (Stop Position)

2. Place fuel shut-off lever in the **OFF** position.
3. Clean drum of all debris and foreign matter.

Stopping the Mixer (Electric)

1. Place the electric motor's **ON/OFF** switch (Figure 23) in the **OFF** position.

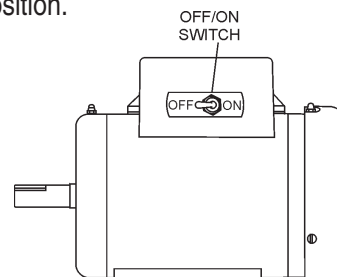

Figure 23. Electric Motor ON/OFF Switch (OFF Position)

2. Disconnect the electric motor's extension cord from its power source.
3. Clean drum of all debris and foreign matter.

EC-92P/S CONCRETE MIXER — MAINTENANCE (ENGINE)

Use Table 8 as a general maintenance guideline when servicing your engine. For more detail engine maintenance information, refer to the engine owner's manual supplied with your engine.

| Table 8. Engine Maintenance Schedule | | | | | | | |
|---|-------------------------|--|------------------------------|------------------------------------|------------------------------------|---------------------------------|------------------------------------|
| DESCRIPTION (3) | OPERATION | BEFORE | FIRST MONTH OR 10 HRS. | EVERY 3 MONTHS OR 25 HRS. | EVERY 6 MONTHS OR 50 HRS. | EVERY YEAR OR 100 HRS. | EVERY 2 YEARS OR 200 HRS. |
| Engine Oil | CHECK | X | | | | | |
| | CHANGE | | X | | | | |
| Air Cleaner | CHECK | X | | | | | |
| | CHANGE | | | X (1) | | | |
| All Nuts & Bolts | Re-tighten If Necessary | X | | | | | |
| Spark Plug | CHECK-CLEAN | | | | X | | |
| | REPLACE | | | | | | X |
| Cooling Fins | CHECK | | | | X | | |
| Spark Arrester | CLEAN | | | | | X | |
| Fuel Tank | CLEAN | | | | | X | |
| Fuel Filter | CHECK | | | | | X | |
| Idle Speed | CHECK-ADJUST | | | | | X (2) | |
| Valve Clearance | CHECK-ADJUST | | | | | | X (2) |
| Fuel lines | CHECK | Every 2 years (replace if necessary) (2) | | | | | |

(1) Service more frequently when used in **DUSTY** areas.

(2) These items should be serviced by your service dealer, unless you have the proper tools and are mechanically proficient. Refer to the HONDA or ROBIN Shop Manual for service procedures.

(3) For commercial use, log hours of operation to determine proper maintenance intervals.

EC-92P/S CONCRETE MIXER — MAINTENANCE (ENGINE)

Maintenance

Perform the scheduled maintenance procedures as defined by Table 6 and below:

DAILY

- Thoroughly remove dirt and oil from the engine and control area. Clean or replace the air cleaner elements as necessary. Check and retighten all fasteners as necessary. Check the gearbox for oil leaks. Repair or replace as needed.

WEEKLY

- Remove the fuel filter cap and clean the inside of the fuel tank.
- Remove or clean the filter at the bottom of the tank.
- Remove and clean the spark plug (Figure 24), then adjust the spark gap to 0.024 ~0.028 inch (0.6~0.7 mm). This unit has electronic ignition, which requires no adjustments.

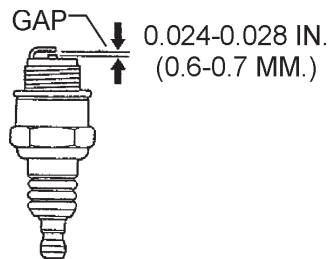

Figure 24. Spark Plug Gap

ENGINE OIL

- Drain the engine oil when the oil is **warm** as shown in Figure 25.
- Remove the oil drain bolt and sealing washer and allow the oil to drain into a suitable container.
- Replace engine oil with recommended type oil as listed in Table 7. For engine oil capacity, see Table 2 (engine specifications). **DO NOT** overfill.
- Install drain bolt with sealing washer and tighten securely.

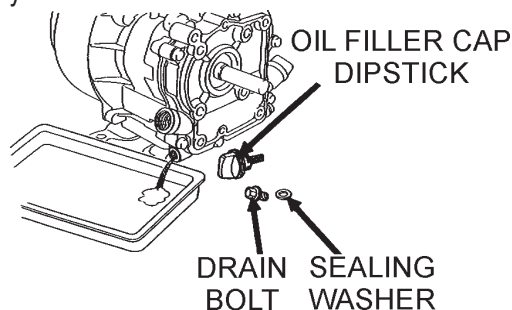

Figure 25. Engine Oil (Draining)

DANGER :



DO NOT use gasoline as a cleaning solvent, because that would create a risk of fire or explosion.

ENGINE AIR CLEANER

- Remove the air cleaner cover and foam filter element as shown in Figure 26.
- Tap the paper filter element (Figure 34) several times on a hard surface to remove dirt, or blow compressed air [not exceeding 30 psi (207 kPa, 2.1 kgf/cm²)] through the filter element from the air cleaner case side. **NEVER** brush off dirt. Brushing will force dirt into the fibers. Replace the paper filter element if it is excessively dirty.
- Clean foam element in warm, soapy water or nonflammable solvent. Rinse and dry thoroughly. Dip the element in clean engine oil and completely squeeze out the excess oil from the element before installing.

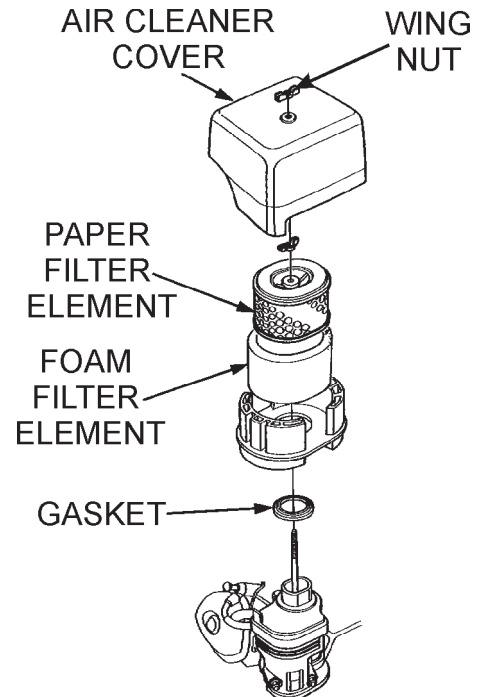

Figure 26. Engine Air Cleaner

EC-92P/S CONCRETE MIXER — MAINTENANCE (MIXER)

Ball Socket and Clamp Face Maintenance

1. If the towing vehicle is equipped with a ball socket, smear socket periodically with multi-purpose grease. This will keep the ball socket well lubricated.
2. Periodically oil **pivot points** and **clamp face** surfaces of coupler with SAE 30 WT. motor oil.
3. When parking or storing your mixer. Keep the coupler off the ground so dirt will not build up in the ball socket.

Grease Fittings (Zerk) Maintenance (Mixer)

There are 3 grease (Figure 27) fittings that will require lubrication. Lubricate these fittings **once a week**. Use lithium base grease, grade NO.1.

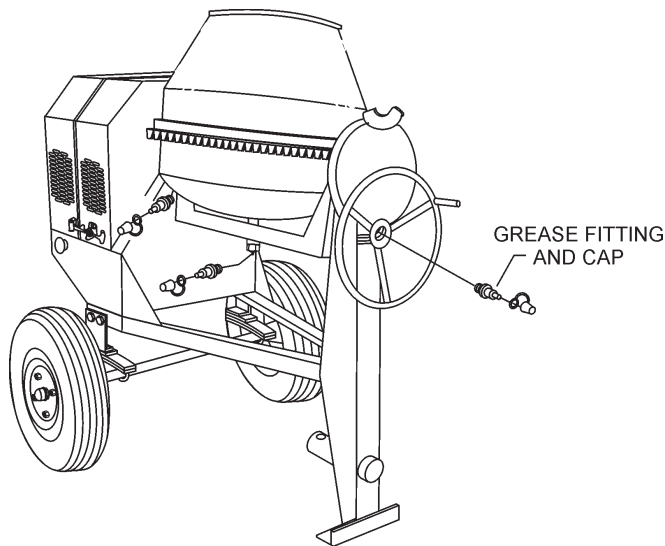

Figure 27. Grease Fittings Mixer

Grease Fittings (Zerk) Maintenance (Electric Motor)

1. There are two grease (Figure 28) fittings at each end of the electric motor that will require lubrication. Lubricate these fittings about **every 16 months**.

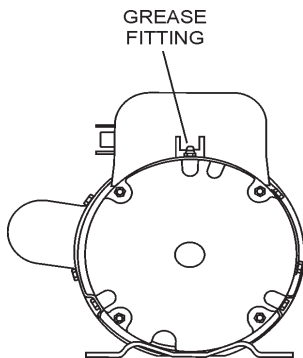

Figure 28. Grease Fittings Electric Motor

2. Use Poleyrex EM (Exxon Mobil) or equivalent lubricant. Clean grease fitting, apply grease gun to fitting (1/2 shot). Remember too much grease or injecting grease too quickly can cause premature bearing failure. Slowly apply the recommended amount of grease, taking a minute or so to apply.

Wheel Bearings

1. After every 3 months of operation, remove the hub dust cap and inspect the wheel bearings (Figure 29). Once a year, or when required, disassemble the wheel hubs remove the old grease and repack the bearings forcing grease between rollers, cone and cage with a good grade of high speed wheel bearing grease (**never** use grease heavier than 265 A.S.T.M. penetration ("No. 2."))

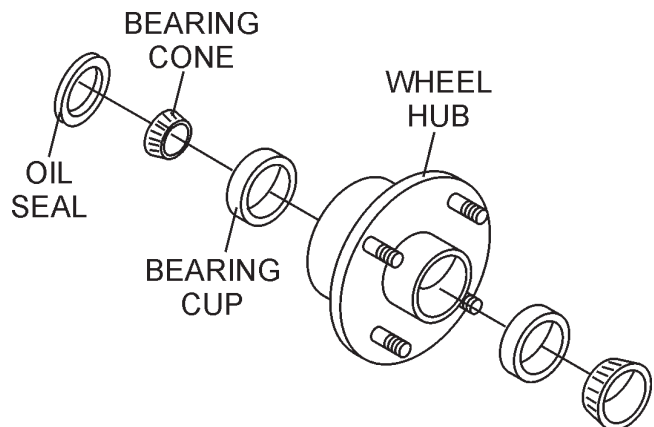

Figure 29. Wheel Hub and Bearings

2. Fill the wheel hub (Figure 29) with grease to the inside diameter of the outer races and also fill the hub grease cap. Reassemble the hub and mount the wheel. Then tighten the adjusting nut, at the same time turn the wheel in both directions, until there is a slight bind to be sure all the bearing surfaces are in contact.

Then back-off the adjusting nut 1/6 to 1/4 turn or to the nearest locking hole or sufficiently to allow the wheel to rotate freely within limits of .001" to .010" end play. Lock the nut at this position. Install the cotter pin and dust cap, and tighten all hardware.

Mixer Cleaning

1. For thorough mix and longer drum life, **always** wash drum out after each use.
2. **NEVER!** pour or spray water over the engine or electric motor.

EC-92P/S CONCRETE MIXER — MAINTENANCE (MIXER)

Tires/Wheels/Lug Nuts

Tires and wheels are a very important and critical components of the trailer. When specifying or replacing the trailer wheels it is important the wheels, tires, and axle are properly matched.

CAUTION:



DO NOT attempt to repair or modify a wheel. **DO NOT** install an inter-tube to correct a leak through the rim.

If the rim is cracked, the air pressure in the inter-tube may cause pieces of the rim to explode (break-off) with great force and can cause serious eye or bodily injury.

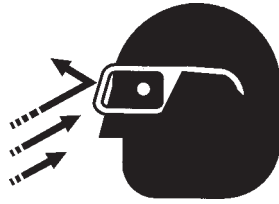

Tires Wear/Inflation

Tire inflation pressure is the most important factor in tire life. Pressure should be checked cold before operation. **DO NOT** bleed air from tires when they are hot. Check inflation pressure weekly during use to insure the maximum tire life and tread wear.

Table 9 (Tire Wear Troubleshooting) will help pinpoint the causes and solutions of tire wear problems.

CAUTION:

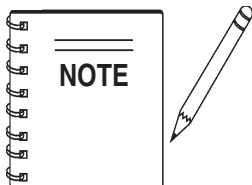
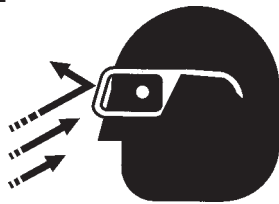

ALWAYS wear safety glasses when removing or installing force fitted parts. Failure to comply may result in serious injury.

TABLE 9. TIRE WEAR TROUBLESHOOTING

| WEAR PATTERN | CAUSE | SOLUTION | |
|--------------|-------------|---------------------------------|---|
| | Center Wear | Over Inflation | Adjust pressure to particular load per tire manufacturer. |
| | Edge Wear | Under Inflation | Adjust pressure to particular load per tire manufacturer. |
| | Side Wear | Loss of chamber or overloading. | Make sure load does not exceed axle rating. Align wheels. |
| | Toe Wear | Incorrect toe-in | Align wheels. |
| | Cupping | Out-of balance | Check bearing adjustment and balance tires. |
| | Flat Spots | Wheel lockup & tire skidding. | Avoid sudden stops when possible and adjust brakes. |

Suspension

The leaf suspension springs and associated components (Figure 30) should be visually inspected every 6,000 miles for signs of excessive wear, elongation of bolt holes, and loosening of fasteners. Replace all damaged parts (suspension) immediately. Torque locknut securing U-clamp to spring leaf between 45 and 50 ft.-lbs.

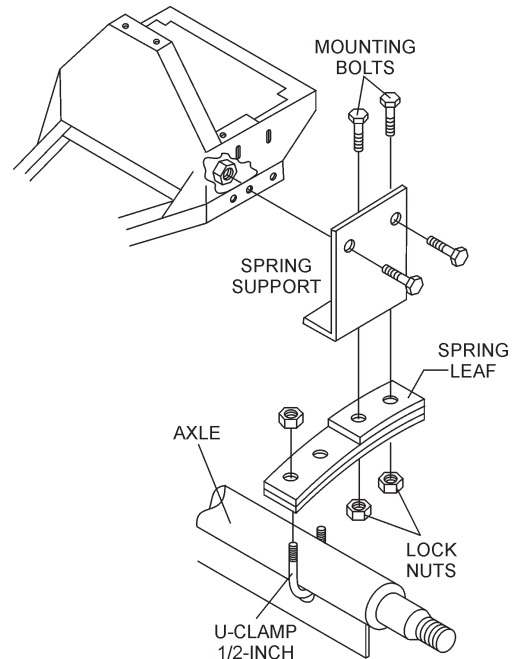
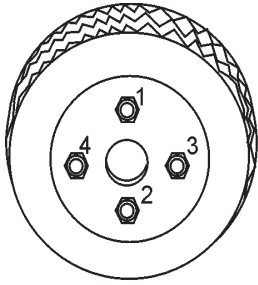
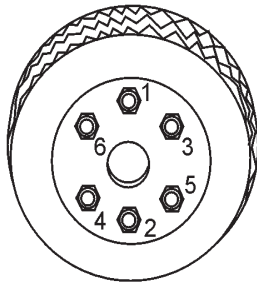

Figure 30. Suspension Components

EC-92P/S CONCRETE MIXER — MAINTENANCE (MIXER)



4-LUG NUTS



6-LUG NUTS

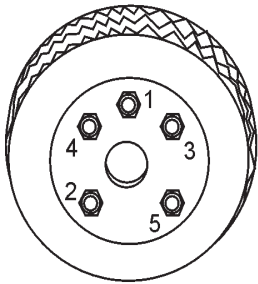

5-LUG NUTS

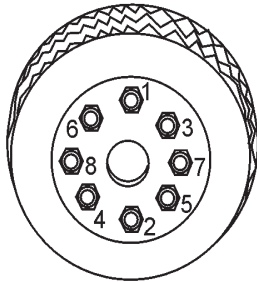

8-LUG NUTS

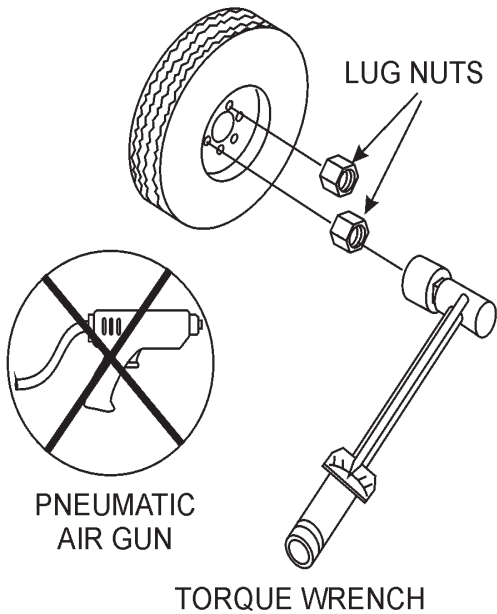
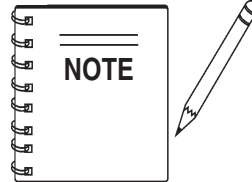

Figure 31. Wheel Lug Nuts Tightening Sequence

Lug Nut Torque Requirements

It is extremely important to apply and maintain proper wheel mounting torque on the trailer. Be sure to use only the fasteners matched to the cone angle of the wheel. Proper procedure for attachment of the wheels is as follows:

1. Start all wheel lug nuts by hand.
2. Torque all lug nuts in sequence. See Figure 31. **DO NOT** torque the wheel lug nuts all the way down. Tighten each lug nut in 3 separate passes as defined by Table 10.
3. After first road use, retorque all lug nuts in sequence. Check all wheel lug nuts periodically.



NEVER! use an pneumatic air gun to tighten wheel lug nuts.

Mixer Storage

For storage of the mixer for over 30 days, the following is recommended:

- Drain the fuel tank completely, or add STA-BIL to the fuel.
- Run the engine until the fuel is completely consumed.
- Completely drain used oil from the engine crankcase and fill with fresh clean oil, then follow the procedures described in the engine manual for engine storage.
- Clean the entire mixer and engine compartment.
- Place the mixing drum in the down position (mouth facing downward).
- Cover the mixer and place it a clean dry area, that is protected from harsh elements.

EC-92P/S CONCRETE MIXER — TROUBLESHOOTING (ENGINE)

Practically all breakdowns can be prevented by proper handling and maintenance inspections, but in the event of a breakdown, please take a remedial action following the

diagnosis based on the Troubleshooting (Tables 10 and 11) information shown below and on the next page. If the problem cannot be remedied, please leave the unit just as it is and consult our company's business office or service plant.

TABLE 10. ENGINE TROUBLESHOOTING

| SYMPTOM | POSSIBLE PROBLEM | SOLUTION |
|---|---|--|
| Difficult to start | | |
| Fuel is available but spark plug will not ignite. (Power available at high tension cable). | Ignition plug being bridge? | Check ignition system. |
| | Carbon deposit at ignition? | Clean or replace ignition. |
| | Short circuit due to defective insulators? | Replace insulators. |
| | Improper spark gap? | Set spark plug gap to the correct gap. |
| Fuel is available but spark plug will not ignite. (Power NOT available at high tension cable). | Short circuit at stop switch? | Check stop switch circuit. Replace stop switch if defective. |
| | Ignition coil defective? | Replace ignition coil. |
| Fuel is available and spark plug ignites (compression normal). | Muffler clogged with carbon deposits? | Clean or replace muffler. |
| | Fuel in use inadequate (water, dust)? | Flush fuel sytem and replace with fresh fuel. |
| | Air Cleaner clogged? | Clean or replace air cleaner. |
| Fuel is available and spark plug ignites (compression low). | Defective cylinder head gasket? | Tighten cylinder head bolts or replace head gasket. |
| | Cylinder worn? | Replace cylinder. |
| | Spark plug loose? | Tighen spark plug. |
| Operation not satisfactory | | |
| Not enough power available (compression normal, no miss-firing). | Air cleaner clogged? | |
| | Air in fuel line? | Bleed (remove air) from fuel line. |
| | Fuel level in carbureator float chamber improper? | Adjust carbureator float |
| | Carbon deposits in cylinder? | Clean or replace cylinder |
| Not enough power available (compression normal, miss-firing). | Ignition coil defective? | Flush fuel sytem and replace with fresh fuel. |
| | Ignition plug often shorts? | Replace ignition wires, clean ignition. |
| | Fuel in use inadequate (water, dust)? | Flush fuel sytem and replace with fresh fuel. |
| Engine overheats. | Excessive carbon depostion in combustion chamber? | Clean or replace crankcase. |
| | Exhaust or muffler clogged with carbon. | Clean or replace muffler. |
| | Spark plug heat value incorrect? | Replace spark plug with correct type spark plug. |

EC-92P/S CONCRETE MIXER — TROUBLESHOOTING (ENGINE/MIXER)

TABLE 10. ENGINE TROUBLESHOOTING (Continued)

| SYMPTOM | POSSIBLE PROBLEM | SOLUTION |
|--------------------------------------|------------------------------------|-----------------------------------|
| Operation not satisfactory | | |
| Rotational speed fluctuates. | Governor adjustment improper? | Adjust governor to correct lever. |
| | Governor spring defective? | Clean or replace ignition. |
| | Fuel flow erratic? | Check fuel line. |
| | Air taken in through suction line? | Check suction line. |
| Recoil starter not working properly. | Dust in rotating part? | Clean recoil starter assembly. |
| | Spring spring failure? | Replace sprial spring. |

TABLE 11. MIXER TROUBLESHOOTING

| SYMPTOM | POSSIBLE PROBLEM | SOLUTION |
|------------------------------|---|---|
| Drum rotates rough. | Defective ring gear? | Check that the ring gear and bearings are not worn . Replace as necessary. |
| | Defective pinion gear? | Check that the pinion gear and bearings are not worn . Replace as necessary. |
| | Worn V-belt? | Replace V-belt. |
| | Loose pulley? | Tighten or replace pulley. |
| Drum does not rotate at all. | Incorrect or no voltage being supplied to electric motor? | Check that the electric motor has the correct supply voltage. |
| | Power to electric motor? | Inspect power source and extension cord. Push reset button on electric motor. Make sure correct voltage is being supplied to motor. |
| | Fuel? | Check level of fuel in fuel tank. Add fuel if necessary. Make sure fuel is being supplied to the engine. Check to ensure that the fuel filter is not clogged. |
| | Broken V-belt? | Replace V-belt. |
| | Defective ring or pinion gears? | Check that the gears and bearings are not broken. Replace as necessary. |
| | Defective electric motor? | Replace electric motor. |

EC-92P/S — EXPLANATION OF CODE IN REMARKS COLUMN

The following section explains the different symbols and remarks used in the Parts section of this manual. Use the help numbers found on the back page of the manual if there are any questions.

The contents and part numbers listed in the parts section are subject to change **without notice**. Multiquip does not guarantee the availability of the parts listed.

Sample Parts List:

| NO. | PART NO. | PART NAME | QTY. | REMARKS |
|-----|----------|----------------------|------|---------------------|
| 1 | 12345 | BOLT | 1 | INCLUDES ITEMS W/* |
| 2* | | WASHER, 1/4 IN. | | NOT SOLD SEPARATELY |
| 2* | 12347 | WASHER, 3/8 IN. | 1 | MQ-45T ONLY |
| 3 | 12348 | HOSE | A/R | MAKE LOCALLY |
| 4 | 12349 | BEARING | 1 | S/N 2345B AND ABOVE |

NO. Column

Unique Symbols - All items with same unique symbol (*, #, +, %, or >) in the number column belong to the same assembly or kit, which is indicated by a note in the “Remarks” column.

Duplicate Item Numbers - Duplicate numbers indicate multiple part numbers are in effect for the same general item, such as different size saw blade guards in use or a part that has been updated on newer versions of the same machine.

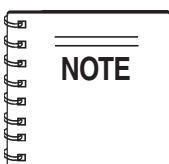

When ordering a part that has more than one item number listed, check the remarks column for help in determining the proper part to order.

PART NO. Column

Numbers Used - Part numbers can be indicated by a number, a blank entry, or TBD.

TBD (To Be Determined) is generally used to show a part that has not been assigned a formal part number at time of publication.

A blank entry generally indicates that the item is not sold separately or is not sold by Multiquip. Other entries will be clarified in the “Remarks” Column.

QTY. Column

Numbers Used - Item quantity can be indicated by a number, a blank entry, or A/R.

A/R (As Required) is generally used for hoses or other parts that are sold in bulk and cut to length.

A blank entry generally indicates that the item is not sold separately. Other entries will be clarified in the “Remarks” Column.

REMARKS Column

Some of the most common notes found in the “Remarks” Column are listed below. Other additional notes needed to describe the item can also be shown.

Assembly/Kit - All items on the parts list with the same unique symbol will be included when this item is purchased.

Indicated by:

“INCLUDES ITEMS W/(unique symbol)”

Serial Number Break - Used to list an effective serial number range where a particular part is used.

Indicated by:

“S/N XXXXX AND BELOW”

“S/N XXXX AND ABOVE”

“S/N XXXX TO S/N XXX”

Specific Model Number Use - Indicates that the part is used only with the specific model number or model number variant listed. It can also be used to show a part is NOT used on a specific model or model number variant.

Indicated by:

“XXXXX ONLY”

“NOT USED ON XXXX”

“Make/Obtain Locally” - Indicates that the part can be purchased at any hardware shop or made out of available items. Examples include battery cables, shims, and certain washers and nuts.

“Not Sold Separately” - Indicates that an item cannot be purchased as a separate item and is either part of an assembly/kit that can be purchased, or is not available for sale through Multiquip.

EC-92P/S CONCRETE MIXER — SUGGESTED SPARE PARTS

EC-92P/S CONCRETE MIXERS 1 TO 4 UNITS WITH HONDA GX240K1HA2 AND ROBIN EH25-2YR000

| Qty. | P/N | Description |
|------|-------------|-------------------------------|
| 2 | 503859 | V-BELT w/GAS ENGINE, HONDA |
| 2 | EM900267 | V-BELT w/ELECTRIC MOTOR |
| 1 | EM940734 | STOP BUTTON w/GAS ENGINE |
| 2 | 491010 | LATCH SET |
| 1 | 505390 | EXPANSION PLUG |
| 2 | EM903026 | SPINDLE BEARING CUP |
| 2 | EM903063 | SPINDLE BEARING CONES |
| 1 | EM505472 | SPACER, DRUM (STEEL BARREL) |
| 2 | 492179 | BEARING JACKSHAFT |
| 2 | EM914288 | SEAL, AXLE |
| 2 | EM903012 | BEARING CUP |
| 2 | EM903049 | BEARING CONE, 7/16" SPINDLE |
| 2 | EM903113 | BEARING CONE, 1-1/16" SPINDLE |
| 2 | 3469 | DUST CAP, AXLE |
| 4 | 17210ZE2515 | ELEMENT, AIR, HONDA |
| 4 | 9807956846 | SPARK PLUG, HONDA |
| 1 | 17620ZH7023 | CAP, FUEL TANK, HONDA |
| 1 | 28462ZE2W11 | ROPE, RECOIL, HONDA |
| 1 | 2705011008 | RECOIL ROPE, ROBIN |
| 4 | 0650140150 | SPARK PLUG, ROBIN |
| 1 | 0430430015 | CAP, FUEL TANK, ROBIN |
| 4 | 2703261008 | ELEMENT, AIR, ROBIN |

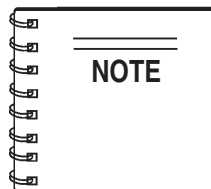

Part numbers on this Suggested Spare Parts List may supercede/replace the P/N's shown in the test pages of this manual.

EC-92P/S CONCRETE MIXER — NAME PLATE AND DECALS

NAME PLATE AND DECALS

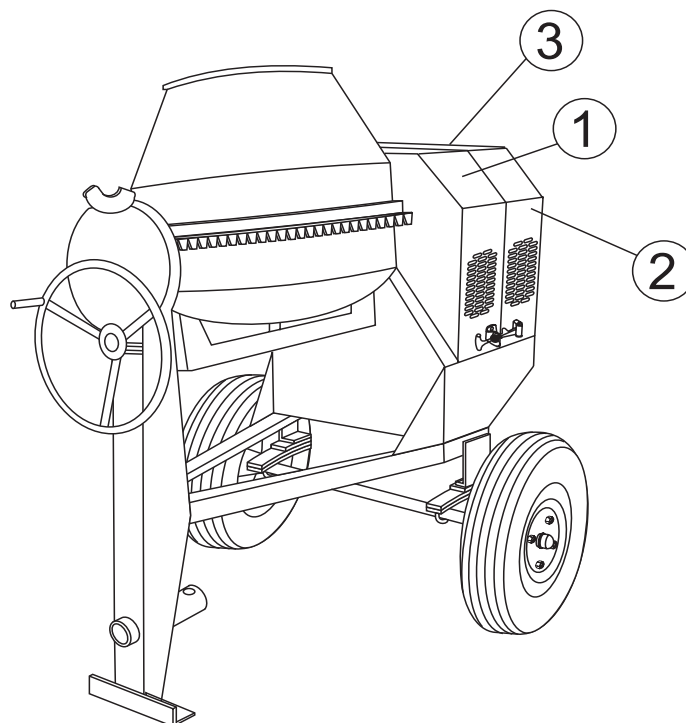
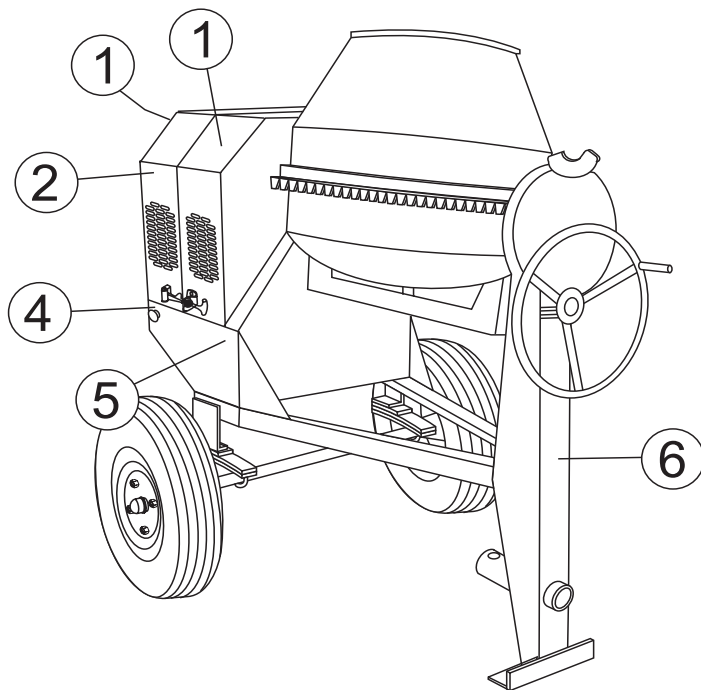

EC-92P/S CONCRETE MIXER— NAME PLATE AND DECALS

NAME PLATE AND DECALS

| <u>NO</u> | <u>PART NO</u> | <u>PART NAME</u> | <u>QTY.</u> | <u>REMARKS</u> |
|-----------|----------------|----------------------------|-------------|--------------------------------|
| 1 | EM510891 | DECAL, MQ ESSICK LOGO | 3 | |
| 2 | CIPDCL160 | DECAL, CRUSH WARNING | 2 | |
| 3 | 504713 | DECAL, SAFETY INSTRUCTIONS | 1 | |
| 4 | EM948630 | DECAL, EMERGENCY STOP | 1 | |
| 5 | DCL151 | DECAL, TOWING INSTRUCTIONS | 1 | |
| 6 | 13118 | DECAL, POWDER COATED | 1 | |
| 7 | | NAMEPLATE | 1 | CONTACT PARTS DEPARTMENT |

SEE DECAL ILLUSTRATIONS ON PAGE 11

PLASTIC BARREL ASSY.

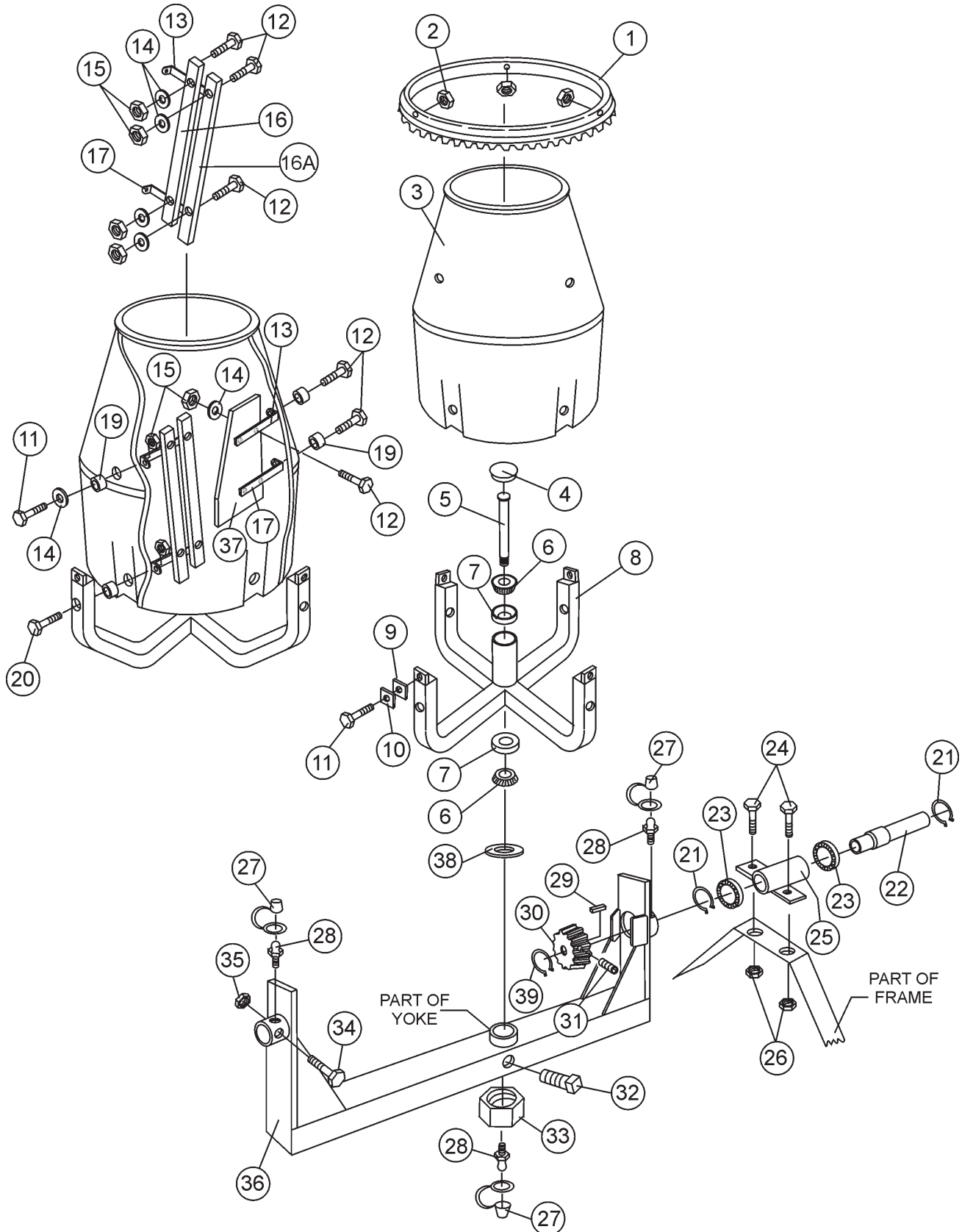

PLASTIC BARREL ASSY.

| <u>NO</u> | <u>PART NO</u> | <u>PART NAME</u> | <u>QTY.</u> | <u>REMARK</u> |
|-----------|----------------|------------------------------|-------------|---------------|
| 1 | 508529 | RING GEAR | 1 | |
| 2 | EM969013 | NUT, LOCK 3/8" NC | 4 | |
| 3 | 508492 | BARREL, PLASTIC 9 CU. FT. | 1 | |
| 4 | 505390 | PLUG, EXPANSION | 1 | |
| 5 | 508491 | KING PIN | 1 | |
| 6 | 510955 | SPINDLE BEARING CONE | 2 | |
| 7 | 510956 | SPINDLE BEARING CUP | 2 | |
| 8 | 508493 | SUPPORT SPIDER | 1 | |
| 9 | 511758 | SHIM PLASTIC #14 | AR | |
| 10 | 511759 | SHIM PLASTIC #16 | AR | |
| 11 | EM963057 | BOLT 3/8" NC 1-1/2" G5 | 8 | |
| 12 | 492378 | BOLT 3/8" NC 1-3/4" G5 | 12 | |
| 13 | 507542 | SUPPORT BRACKET, UPPER | 4 | |
| 14 | 492598 | WASHER, FLAT | 16 | |
| 15 | 492583 | NUT, HEX 3/8" NC | 16 | |
| 16 | 508497 | BLADE, VERT. LONG | 2 | |
| 16A | 508498 | BLADE, VERT. SHORT | 2 | |
| 17 | 507541 | SUPPORT BRACKET, LOWER | 4 | |
| 19 | 507538 | SPACER MC8079 | 4 | |
| 20 | 490166 | BOLT, HEX 3/8" NC X 3-1/2" G | 4 | |
| 21 | EM926036 | RING, RETENTION | 2 | |
| 22 | 502064 | DRIVE PINION SHAFT | 1 | |
| 23 | 492179 | BEARING, PINION SHAFT | 2 | |
| 24 | EM963692 | BOLT 1/2" NC X 1-1/2" G5 | 2 | |
| 25 | 503597 | HOUSING, JACKSHAFT | 1 | |
| 26 | 492584 | LOCKNUT, HEX 1/2" NC | 2 | |
| 27 | 491008 | CAP, GREASE FITTING | 3 | |
| 28 | EM916001 | GREASE FITTING 1/8" NPT | 3 | |
| 29 | 500275 | SQUARE KEY 1/4 X 35 MM | 1 | |
| 30 | 501796 | DRIVE PINION | 1 | |
| 31 | 492468 | ALLEN SCREW 5/16 NC 1/2" | 1 | |
| 32 | 492491 | SET SCREW 1/2" X 1" NC | 1 | |
| 33 | 07037-024 | NUT, HEX LOWER 1-1/2" NF | 1 | |
| 34 | 492406 | BOLT 5/8" NC X 1-1/4" NC | 1 | |
| 35 | EM969023 | LOCKNUT, HEX 5/8" | 1 | |
| 36 | 510647 | YOKE | 1 | |
| 37 | 508496 | BLADE, PLASTIC (SHOVEL) | 2 | |
| 38 | 500980 | WASHER, FLAT 1-9/16" | 1 | |
| 39 | 490961 | RING, RETENTION | 1 | |

STEEL BARREL ASSY.

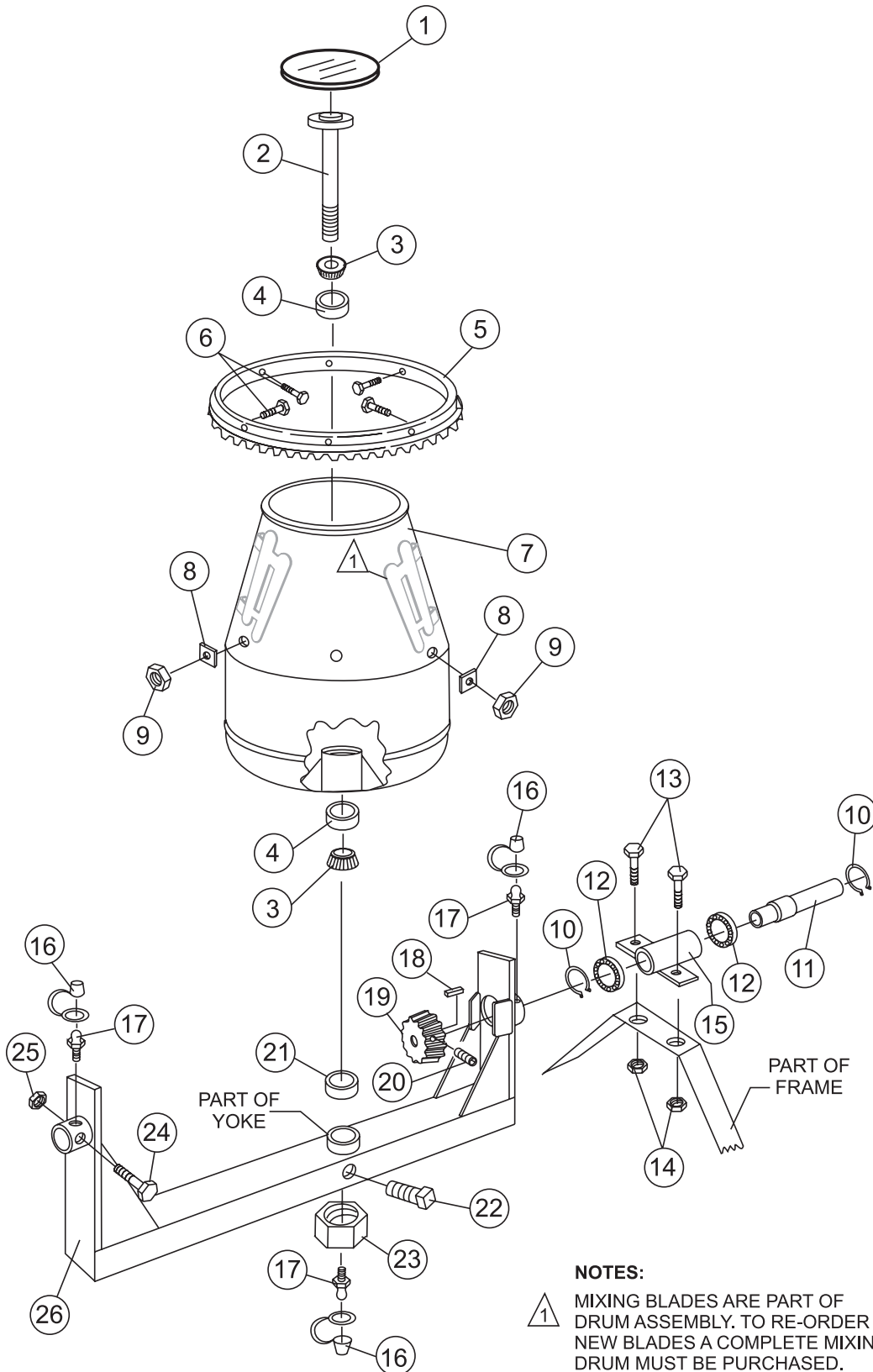

STEEL BARREL ASSY.

| <u>NO</u> | <u>PART NO</u> | <u>PART NAME</u> | <u>QTY.</u> | <u>REMARK</u> |
|-----------|----------------|--------------------------------|-------------|-----------------|
| 1 | 505390 | PLUG, EXPANSION | 1 | |
| 2 | 505469 | KING PIN | 1 | |
| 3 | 510955 | SPINDLE BEARING 5/8" CONE | 2 | |
| 4 | 510956 | SPINDLE BEARING CUP | 2 | |
| 5 | 490338 | RING GEAR | 1 | |
| 6 | EM963057 | BOLT 3/8" NC 1-1/2" G5 | 6 | |
| 7 | 505473 | BARREL, STEEL 9 CU. FT. | 1 | |
| 8 | 511729 | SHIM 0.10 THICK | AR | |
| 8 | 511730 | SHIM 0.14 THICK | AR | |
| 8 | 511731 | SHIM 0.187 THICK | AR | |
| 8 | 511732 | SHIM 0.25 THICK | AR | |
| 9 | EM969013 | NUT, LOCK 3/8" NC | 6 | |
| 10 | 490962 | RING, RETENTION | 2 | |
| 11 | 502064 | DRIVE PINION SHAFT | 1 | |
| 12 | 492179 | PINION SHAFT BEARING | 2 | |
| 13 | EM963692 | BOLT 1/2" NC X 1-1/2" G5 | 2 | |
| 14 | 492584 | LOCKNUT, HEX 1/2" NC | 2 | |
| 15 | 503597 | HOUSING, JACKSHAFT | 1 | |
| 16 | 491008 | CAP, GREASE FITTING | 3 | |
| 17 | EM916001 | GREASE FITTING 1/8" NPT | 3..... | REPLACES 491698 |
| 18 | 500275 | SQUARE KEY 1/4" X 40 MM | 1 | |
| 19 | 501796 | DRIVE PINION | 1 | |
| 20 | 492468 | ALLEN SCREW 5/16 NC 1/2" | 2 | |
| 21 | EM505472 | SPACER, BARREL | 1 | |
| 22 | 492491 | SET SCREW 1/2" X 1-1/2" NC | 1 | |
| 23 | EM968306 | NUT, HEX LOWER 1-1/2" NF | 1 | REPLACES 492579 |
| 24 | 492406 | BOLT 5/8" NC X 1-1/4" NC | 1 | |
| 25 | EM969023 | LOCKNUT, HEX 5/8" | 1 | |
| 26 | 510593 | YOKE | 1 | |
| 27 | 490961 | RING, RETENTION | 1 | |

EC-92P/S — MAIN FRAME ASSEMBLY

MAIN FRAME ASSY.

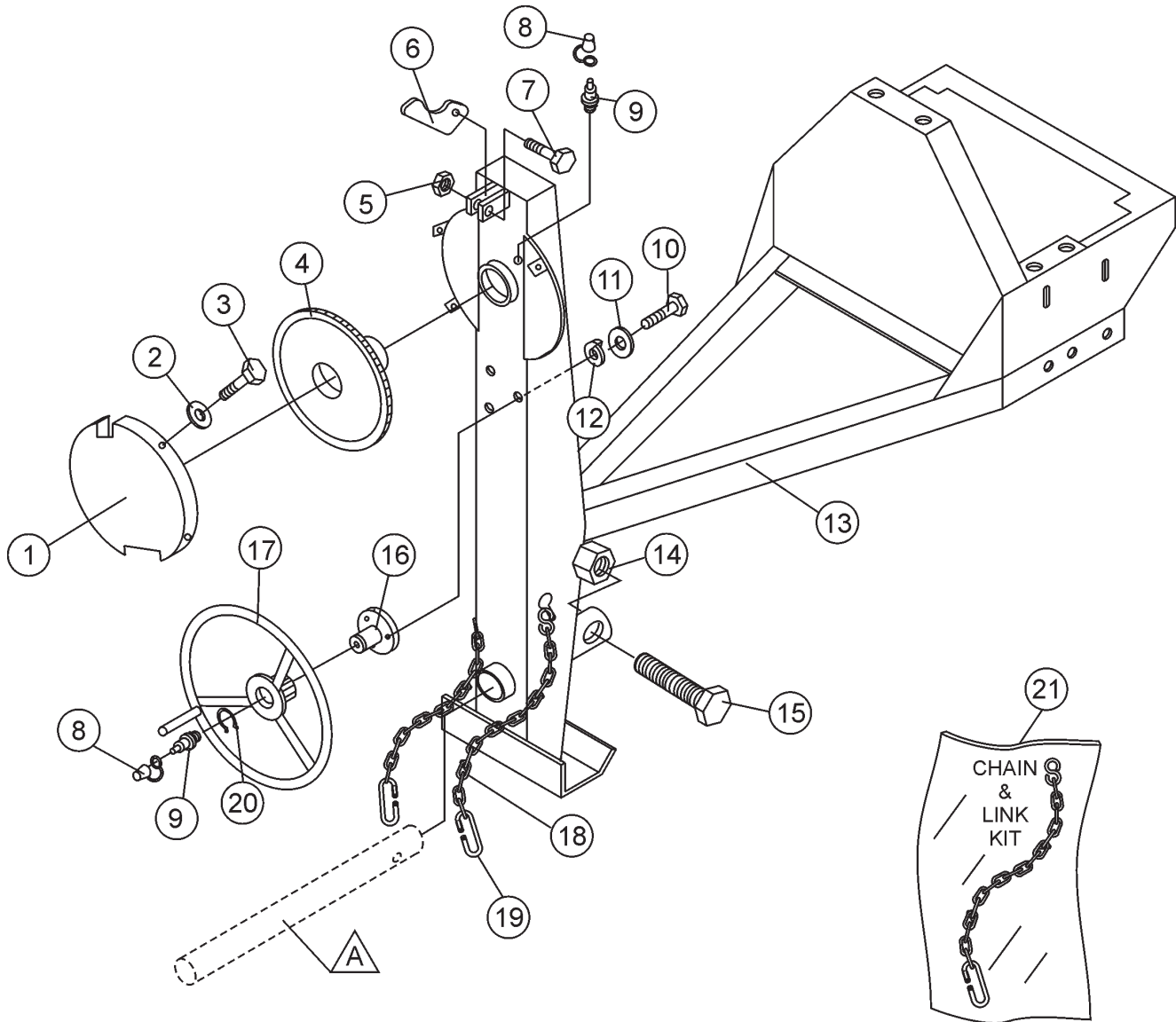

A OPTIONAL TOW BARS

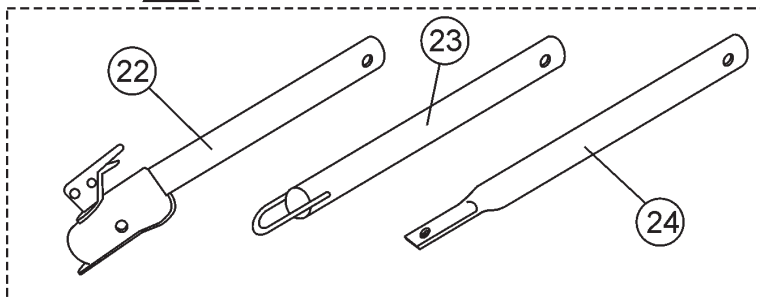

EC-92P/S — MAIN FRAME ASSEMBLY

MAIN FRAME ASSY.

| <u>NO</u> | <u>PART NO</u> | <u>PART NAME</u> | <u>QTY.</u> | <u>REMARK</u> |
|-----------|----------------|---------------------------------------|-------------|---------------------|
| 1 | 500198 | GUARD, GEAR WHEEL | 1 | |
| 2 | 2101402 | WASHER, LOCK 1/4" | 4 | |
| 3 | 492284 | ROUND HEAD BOLT 1/4" NC 3/8 G2" | 4..... | REPLACES 492279 |
| 4 | 502063 | DUMP GEAR | 1 | |
| 5 | 492584 | NUT, LOCK 1/2" NC | 1 | |
| 6 | 490895 | DUMP LATCH | 1 | |
| 7 | 492395 | BOLT 1/2" NC X 1-3/4" G5 | 1 | |
| 8 | EM916001 | GREASE FITTING 1/8" NPT | 2..... | REPLACES 491698 |
| 9 | 491008 | GREASE CAP | 2 | |
| 10 | EM963055 | BOLT 3/8" NC X 3/4" G5 | 3 | |
| 11 | 3109092 | WASHER, FLAT 3/8" | 3 | |
| 12 | 0166 A | WASHER, LOCK 3/8" | 3 | |
| 13 | 503595 | FRAME | 1 | |
| 14 | EM124 | BOLT 1/2"-13 X 4 G5 | 1 | |
| 15 | 10176 | LOCK NUT 1/2 NC | 1..... | REPLACES 492586 |
| 16 | 500167 | HANDWHEEL SHAFT | 1 | |
| 17 | 501808 | HANDWHEEL | 1 | |
| 18 * | | SAFETY CHAIN | 1 | |
| 19 * | 01004 | CONNECTOR LINK | 2 | |
| 20 | 490961 | RING RETAINING | 1 | |
| 21 | 13363KIT | CHAIN AND LINK KIT | 1 | INCLUDES ITEMS W/ * |
| 22 | HBC-1 | BALL HITCH 2-INCH | 1..... | CONTACT UNIT SALES |
| 23 | HLC-1 | LOOP HITCH | 1..... | CONTACT UNIT SALES |
| 24 | HPC-1 | PIN HITCH 1-INCH | 1..... | CONTACT UNIT SALES |

AXLE ASSY.

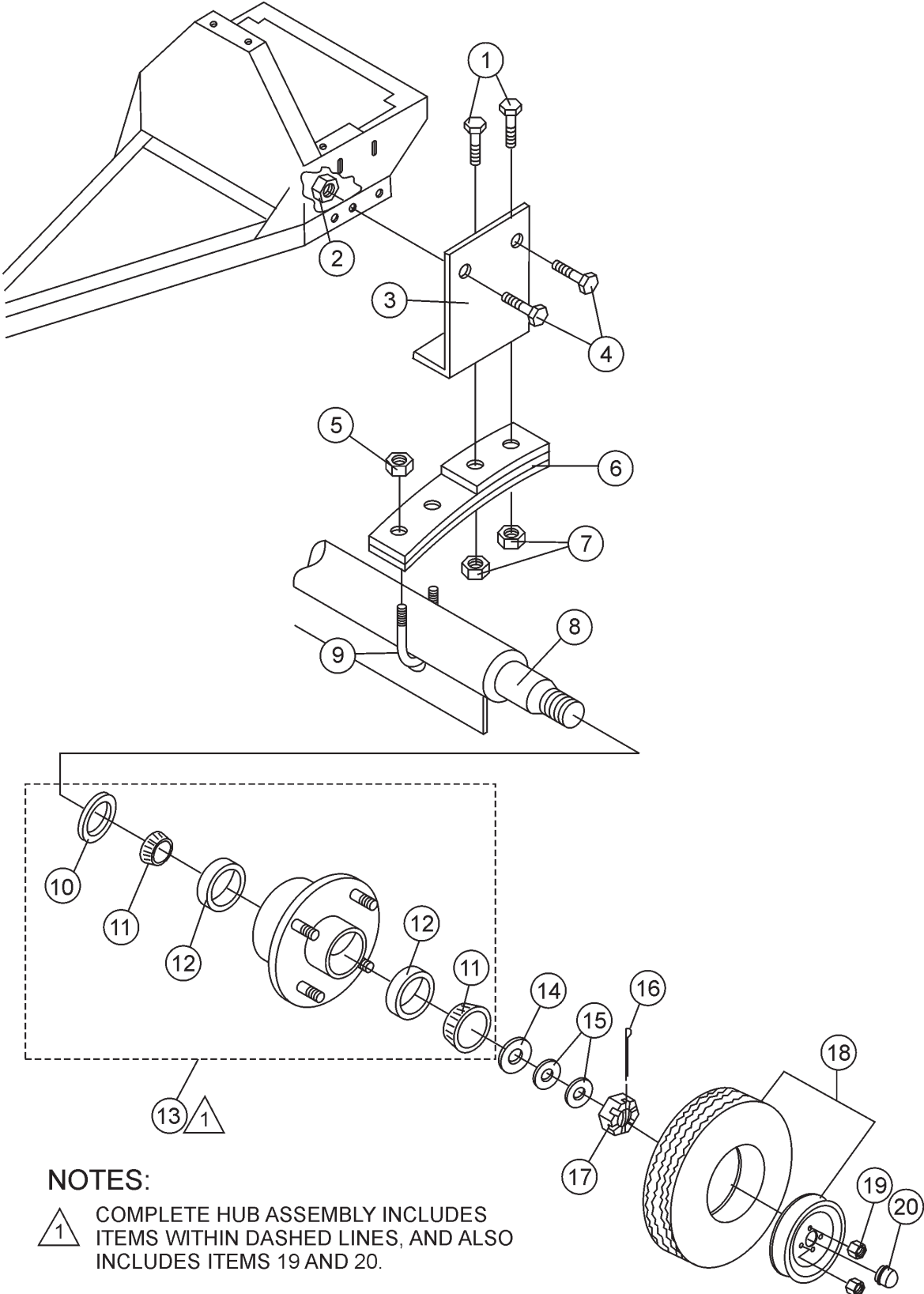

NOTES:

△ 1 COMPLETE HUB ASSEMBLY INCLUDES ITEMS WITHIN DASHED LINES, AND ALSO INCLUDES ITEMS 19 AND 20.

EC-92P/S — AXLE ASSEMBLY

AXLE ASSY.

| <u>NO</u> | <u>PART NO</u> | <u>PART NAME</u> | <u>QTY.</u> | <u>REMARK</u> |
|-----------|----------------|---|-------------|---------------------------------------|
| 1 | 492395 | BOLT 1/2" NC 1-3/4" G5 | 4 | |
| 2 | EM969023 | LOCK NUT 5/8" NC | 4 | |
| 3 | 501030 | SPRING SUPPORT | 2 | |
| 4 | 492406 | BOLT 5/8" NC 1-1/2" G5 | 4 | |
| 5 | 492589 | NUT 1/2" NF | 4 | |
| 6 | 491928 | SPRING LEAF | 2 | |
| 7 | 492584 | NUT, HEX 1/2" | 4 | |
| 8 | 511336 | AXLE 1-1/16" SPINDLE | 1 | |
| 8 | 502039 | AXLE 7/8" SPINDLE | 1 | |
| 9 | 500617 | U-CLAMP | 2 | |
| 10*# | EM914288 | OIL SEAL | 2 | |
| 11* | EM903049 | BEARING CONE, (7/8" SPINDLE) | 4 | |
| 11# | EM903113 | BEARING CONE, (1-1/16" SPINDLE) | 4 | |
| 12*# | EM903012 | BEARING CUP | 4 | |
| 13 | 3504 | HUB ASSY., 4-BOLT (7/8" SPINDLE) | 2 | INCLUDES ITEMS W/* REPLACES 493235 |
| 13 | EM941306 | HUB ASSY., 4-BOLT (1-1/16" SPINDLE) | 2 | INCLUDES ITEMS W/# |
| 14 | EM511159 | WASHER, FLAT, .087" THICKNESS | 2 | |
| 15 | EM501299 | WASHER, FLAT, .135" THICKNESS | AR | |
| 16 | 491688 | COTTER PIN 1/8" X 1-1/2' | 2 | |
| 17 | 12426 | NUT, SLOTTED HEX JAM (7/8" SPINDLE) | 2 | REPLACES 3068 |
| 17 | 8164 | NUT, SLOTTED HEX JAM (1-1/16" SPINDLE) | 2 | |
| 18 | 3005 | TIRE AND RIM, CARLISE | 2 | |
| 18 | 493236C | TIRE AND RIM, UNIROYAL | 2 | |
| 19*# | 8115 | LUG NUTS | 8 | |
| 20*# | 3469 | DUST CAP | 2 | |

CABINET ASSY.

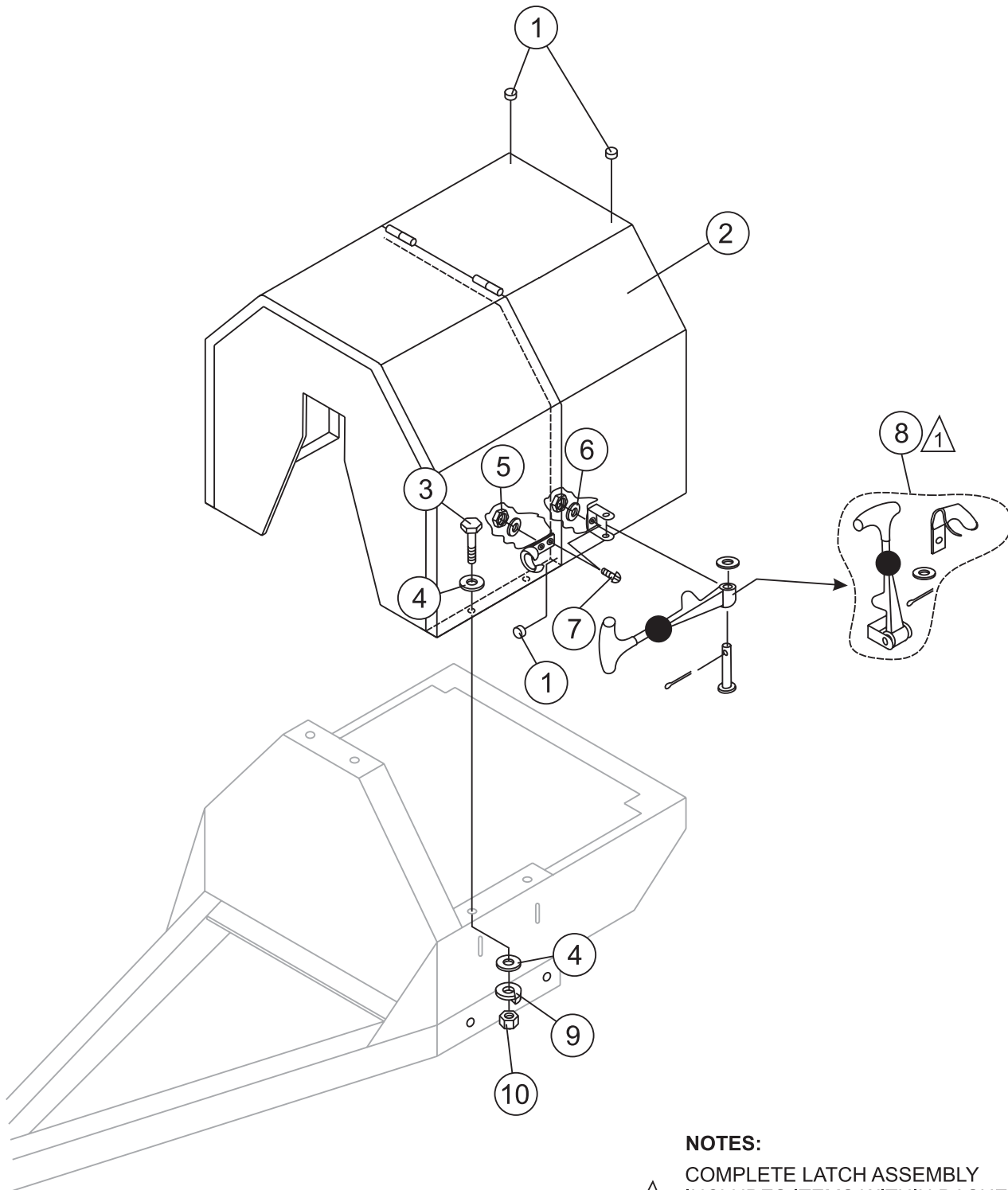

NOTES:



COMPLETE LATCH ASSEMBLY
INCLUDES ITEMS WITHIN DASHED
LINES. ITEMS CANNOT BE PURCHASED
SEPARATELY.

CABINET ASSY.

| <u>NO</u> | <u>PART NO</u> | <u>PART NAME</u> | <u>QTY.</u> | <u>REMARKS</u> |
|-----------|----------------|-------------------------------------|-------------|-----------------------|
| 1 | 490202 | RUBBER PROTECTOR | 4 | |
| 2 | 503598 | CABINET, ENGINE ASSY. | 1 | |
| 3 | 492363 | BOLT 5/16" NC X 3/4" G5 | 4 | |
| 4 | EM923023 | WASHER, FLAT 5/16" | 8 | |
| 5 | 13287 | LOCK NUT 8-32 | 6 | REPLACEMENT PART ONLY |
| 6 | 2203 | WASHER, FLAT #10 | 6 | REPLACEMENT PART ONLY |
| 7 | 1307 | RHMS 8-32 X 1/2" | 6 | REPLACEMENT PART ONLY |
| 8 | 491010 | LATCH ASSY., COMPLETE | 2 | |
| 9 | EM923343 | WASHER, LOCK 5/16" | 4 | |
| 10 | 2105164 | NUT 5/16" NC G5 | 4 | |
| 11 | EM974007 | PAINT, SPRAY CAN 12 OZ. TRAFFIC RED | AR | |

EC-92P/S — GAS ENGINE MOUNTING PLATE ASSEMBLY

GAS ENGINE MOUNTING PLATE ASSY.

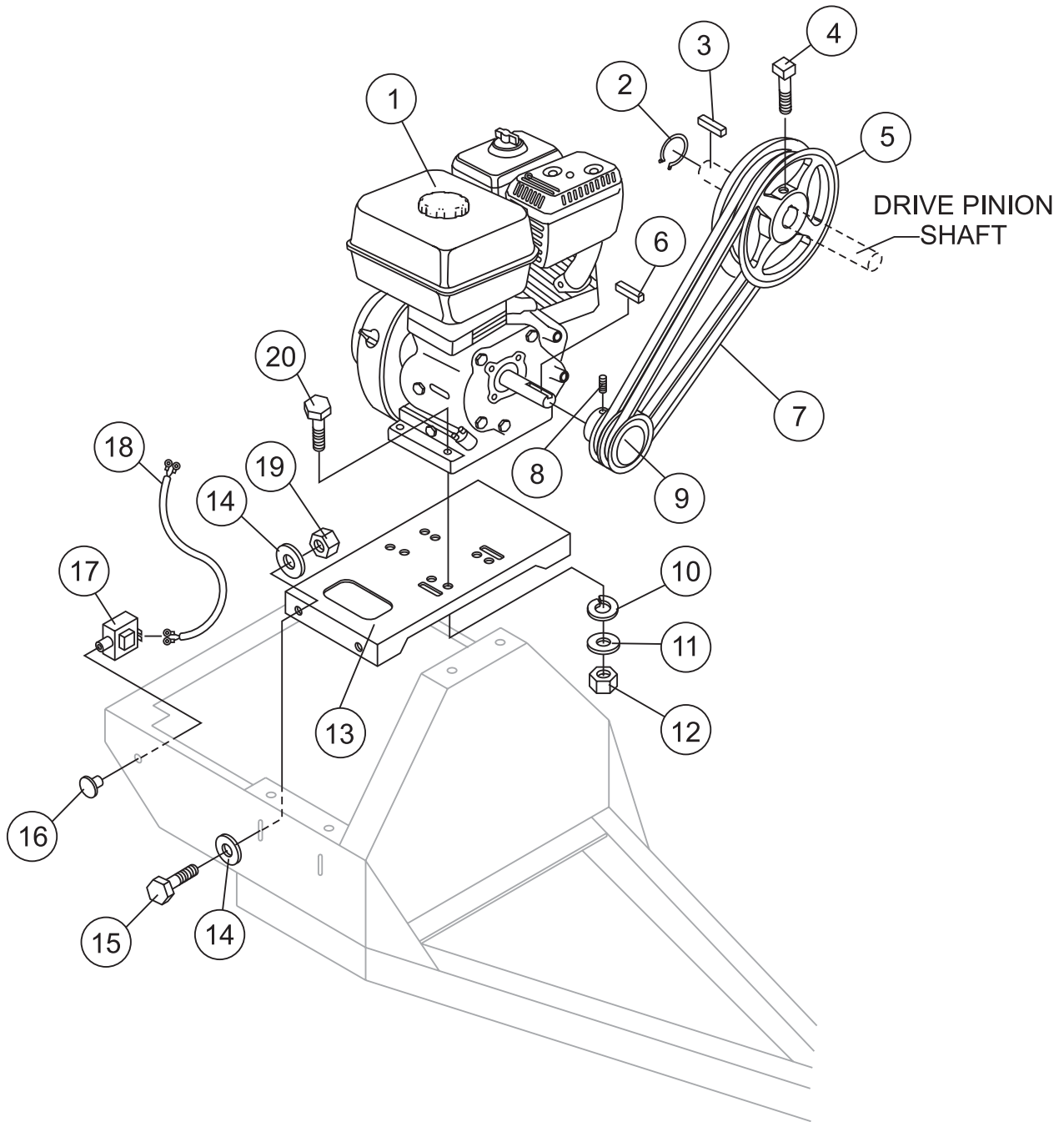

EC-92P/S — GAS ENGINE MOUNTING PLATE ASSEMBLY

GAS ENGINE MOUNTING PLATE ASSY.

| <u>NO</u> | <u>PART NO</u> | <u>PART NAME</u> | <u>QTY.</u> | <u>REMARKS</u> |
|-----------|----------------|-----------------------------|-------------|-----------------------|
| 1 | GX240K1HA2 | ENGINE, HONDA 8.0 HP | 1 | |
| 1 | EH252YR000 | ENGINE, ROBIN 8.5 HP | 1 | |
| 2 | 490956 | RING, RETAINING | 1 | |
| 3 | 500275 | SQUARE KEY | 1 | |
| 4 | 492468 | SET SCREW 5/16" NC X 3/4" | 1 | |
| 5 | 492078 | UPPER PULLEY | 1 | |
| 6 | 501019 | SQUARE KEY 3/16" X 45 MM | 1 | |
| 7 | 503859 | V-BELT A-38, HONDA | 2 | |
| 7 | 491112 | V-BELT A-40, ROBIN | 2 | |
| 8 | 492468 | ALLEN SCREW 5/16" NC X 1/2" | 1 | |
| 9 | 492075 | LOWER PULLEY | 1 | |
| 10 | EM923343 | WASHER, LOCK 5/16" | 4 | |
| 11 | EM923023 | WASHER, FLAT 5/16" | 4 | |
| 12 | 492553 | NUT, HEX 5/16 X18 NC G5 | 4 | |
| 13 | 502041 | BASE PLATE ENGINE | 1 | |
| 14 | 492600 | WASHER, FLAT 1/2" | 8 | |
| 15 | EM963692 | BOLT, HEX 1/2" NC 1-1/2" G5 | 4 | |
| 16 | 29174-001 | BUTTON, STOP | 1 | |
| 17 | EM940734 | SWITCH, STOP | 1 | REPLACES 491845 |
| 18 | 510573 | ENGINE CABLE HARNESS | 1 | |
| 19 | 492584 | LOCKNUT 1/2" | 4 | |
| 20 | 492367 | BOLT 5/16" X 1-3/4" G5 | 4 | |

EC-92P/S — ELECTRIC MOTOR MOUNTING PLATE ASSEMBLY

ELECTRIC MOTOR MOUNTING PLATE ASSY.

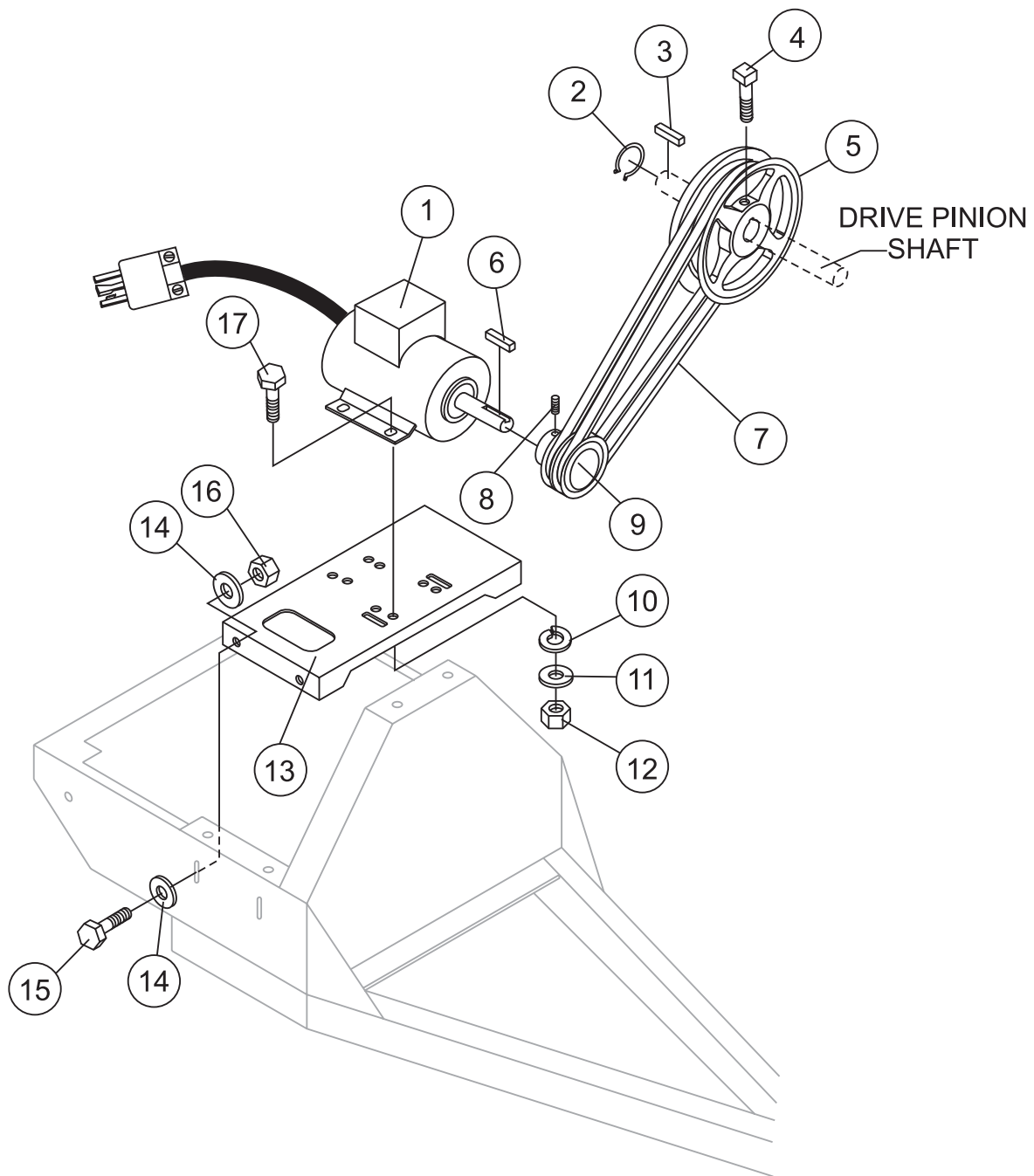

EC-92P/S — ELECTRIC MOTOR MOUNTING PLATE ASSEMBLY

ELECTRIC MOTOR MOUNTING PLATE ASSY.

| <u>NO</u> | <u>PART NO</u> | <u>PART NAME</u> | <u>QTY.</u> | <u>REMARKS</u> |
|-----------|----------------|-----------------------------|-------------|----------------|
| 1 | P145K17DB45A | MOTOR, ELECTRIC 1.5 HP | 1 | |
| 2 | 490956 | RING, RETAINING | 1 | |
| 3 | 500275 | SQUARE KEY | 1 | |
| 4 | 492468 | SET SCREW 5/16" NC X 3/4" | 1 | |
| 5 | 502210 | UPPER PULLEY | 1 | |
| 6 | 501019 | SQUARE KEY 3/16" X 45 MM | 1 | |
| 7 | EM900267 | V-BELT, A45 | 2 | |
| 8 | 492468 | ALLEN SCREW 5/16" NC X 1/2" | 1 | |
| 9 | 502213 | DRIVE PULLEY | 1 | |
| 10 | EM923343 | WASHER, LOCK 5/16" | 4 | |
| 11 | EM923023 | WASHER, FLAT 5/16" | 4 | |
| 12 | 2105164 | NUT, HEX 5/16 X18 NC G5 | 4 | |
| 13 | 503599 | BASE PLATE ENGINE | 1 | |
| 14 | 492600 | WASHER, FLAT 1/2" | 8 | |
| 15 | EM963692 | BOLT, HEX 1/2" NC 1-1/2" G5 | 4 | |
| 16 | 492584 | LOCKNUT 1/2" | 4 | |
| 17 | 0202 | BOLT 5/16" X 1" G5 | 4 | |

HONDA GX240K1HA2 ENGINE — AIR CLEANER ASSY.

AIR CLEANER ASSY.

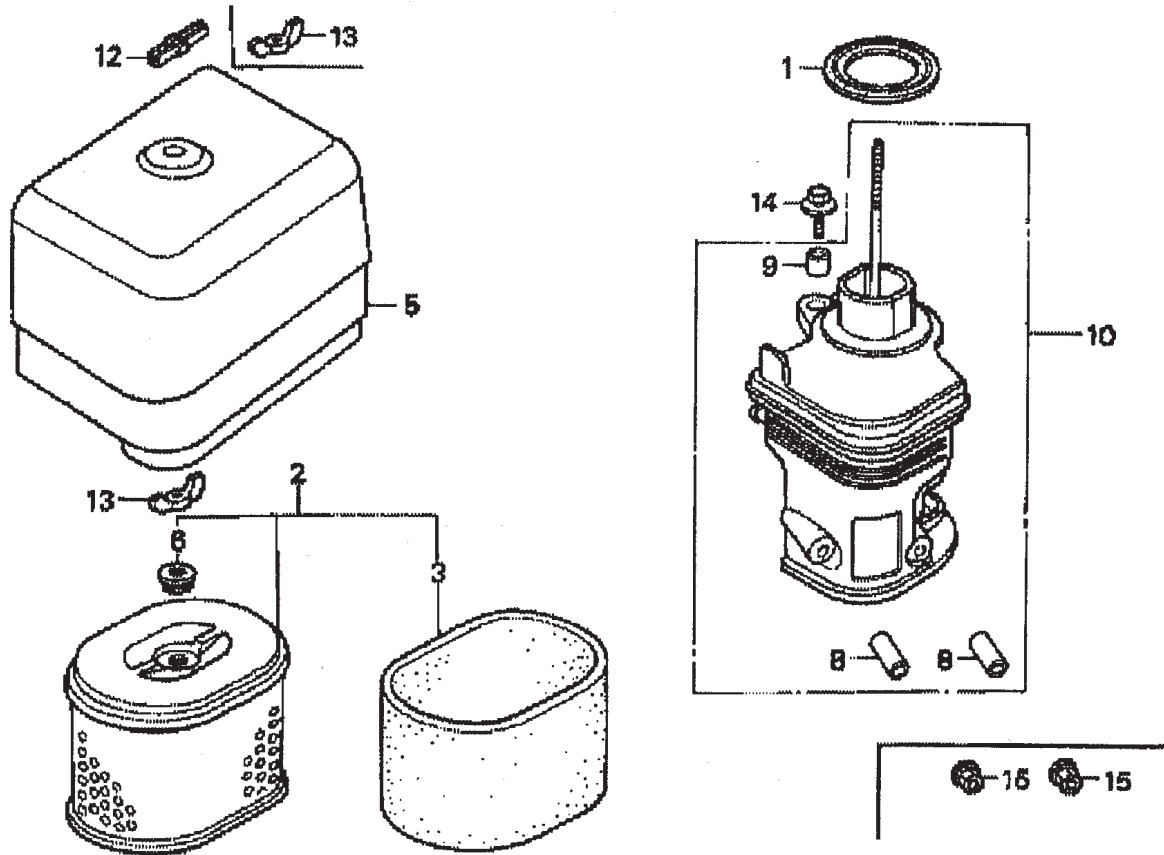

HONDA GX240K1HA2 ENGINE — AIR CLEANER ASSY.

AIR CLEANER ASSY.

| <u>NO.</u> | <u>PART NO.</u> | <u>PART NAME</u> | <u>QTY.</u> | <u>REMARKS</u> |
|------------|-----------------|--------------------------------|-------------|-------------------|
| 1 | 16271ZE2000 | GASKET, ELBOW | 1 | INCLUDES ITEM W/* |
| 2 | 17210ZE2515 | ELEMENT, AIR CLEANER, DUAL | 1 | |
| 3* | 17218ZE2505 | FILTER, OUTER | 1 | |
| 5 | 17231ZH9820 | COVER, AIR CLEANER | 1 | |
| 6 | 17232891000 | GROMMET, AIR CLEANER | 1 | |
| 8# | 17238ZE2310 | COLLAR, AIR CLEANER | 2 | |
| 9# | 17239ZE1000 | COLLAR B, AIR CLEANER | 1 | |
| 10 | 17410ZE2020 | ELBOW COMP., AIR CLEANER | 1 | INCLUDES ITEM W/# |
| 12 | 0037806000 | WINGNUT 6MM | 1 | |
| 13 | 90325044000 | WINGNUT, TOOL BOX SETTING | 2 | |
| 14 | 90009ZE2003 | BOLT- WASHER 6 X 22 | 1 | |
| 15 | 9405006000 | NUT, FLANGE 6MM | 2 | |

HONDA GX240K1HA2 ENGINE — CAMSHAFT ASSY.

CAMSHAFT ASSY.

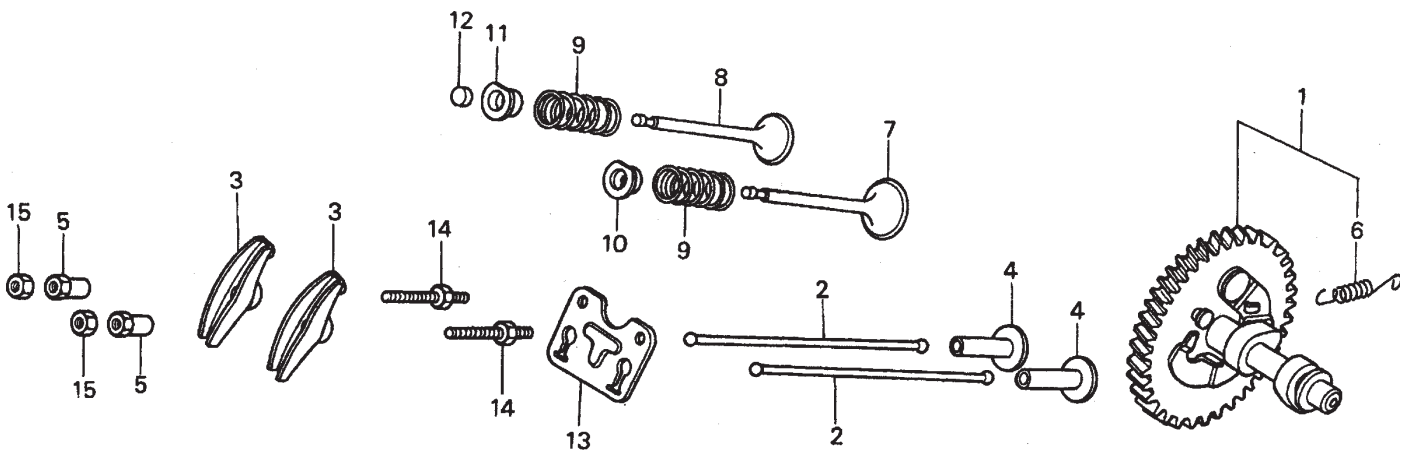

HONDA GX240K1HA2 ENGINE — CAMSHAFT ASSY.

CAMSHAFT ASSY.

| <u>NO.</u> | <u>PART NO.</u> | <u>PART NAME</u> | <u>QTY.</u> | <u>REMARKS</u> |
|------------|-----------------|----------------------------|-------------|-------------------|
| 1 | 14100ZE2W01 | CAMSHAFT ASSY. | 1 | INCLUDES ITEM W/* |
| 1 | 14100ZE2306 | CAMSHAFT | 1 | |
| 2 | 14410ZE2013 | ROD PUSH | 2 | |
| 3 | 14431ZE2010 | ARM VALVE ROCKER | 2 | |
| 4 | 14441ZE2000 | LIFTER VALVE | 2 | |
| 5 | 14451ZE1013 | PIVOT ROCKER ARM | 2 | |
| 6* | 14568ZE1000 | SPRING, WEIGHT RETURN | 1 | |
| 7 | 14711ZE2000 | VALVE, IN. | 1 | |
| 8 | 14721ZE2000 | VALVE, EX. | 1 | |
| 9 | 14751ZE2003 | SPRING, VALVE | 2 | |
| 10 | 14771ZE2000 | RETAINER, IN. VALVE SPRING | 1 | |
| 11 | 14773ZE2000 | RETAINER, EX. VALVE SPRING | 1 | |
| 12 | 14781ZE2000 | ROTATOR, VALVE | 1 | |
| 13 | 14791ZE2010 | PLATE, PUSH ROD GUIDE | 1 | |
| 14 | 90012ZE0010 | BOLT, PIVOT 8MM | 2 | |
| 15 | 90206ZE1000 | NUT, PIVOT ADJ. | 2 | |

HONDA GX240K1HA2 ENGINE — CARBURETOR ASSY.

CARBURETOR ASSY.

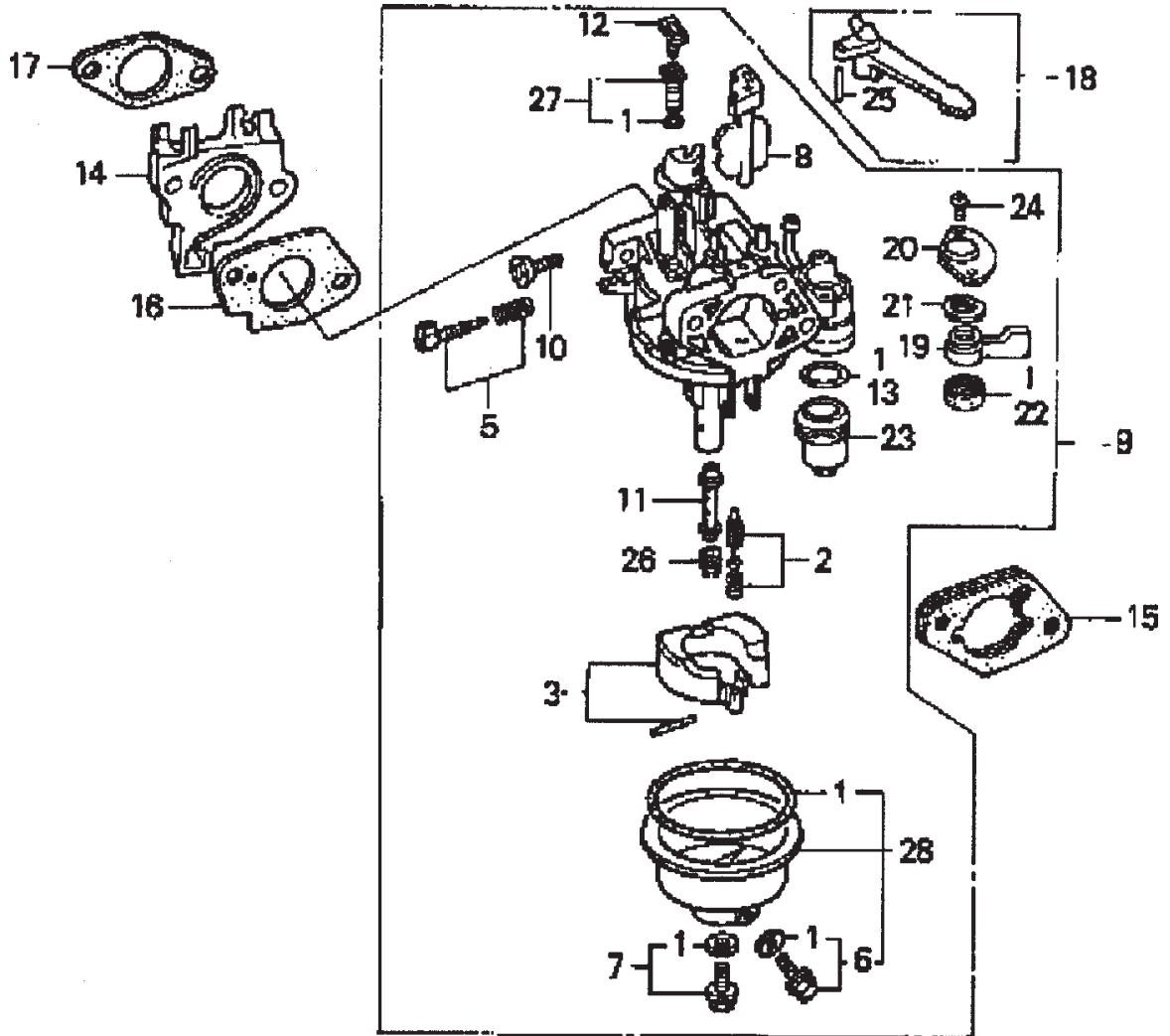

HONDA GX240K1HA2 ENGINE — CARBURETOR ASSY.

CARBURETOR ASSY.

| <u>NO.</u> | <u>PART NO.</u> | <u>PART NAME</u> | <u>QTY.</u> | <u>REMARKS</u> |
|------------|-----------------|--------------------------|-------------|--------------------|
| 1*+ | 16010ZE2812 | GASKET SET | 1 | |
| 2* | 16011ZA0931 | VALVE SET, FLOAT | 1 | |
| 3* | 16013ZA0931 | FLOAT SET | 1 | |
| 5* | 16016ZHW01 | SCREW SET | 1 | |
| 6*+ | 16024ZE1811 | SCREW SET, DRAIN | 1 | |
| 7*+ | 16028ZE0005 | SCREW SET B | 1 | |
| 8* | 16028ZE2005 | CHOKE SET | 1 | |
| 9* | 16100ZE2W71 | CARBURETOR ASSY..... | 1 | INCLUDES ITEMS W/* |
| 10* | 16124ZE0005 | SCREW, THROTTLE STOP | 1 | |
| 11* | 16166ZE2W70 | NOZZLE, MAIN | 1 | |
| 12* | 16075GHBB00 | COLLAR, SET | 1 | |
| 13* | 16075GHBB00 | O-RING | 1 | |
| 14 | 16211ZE2000 | INSULATOR, CARB. | 1 | |
| 15 | 16220ZA0702 | SPACER COMP., CARB. | 1 | |
| 16 | 16221ZA0800 | GASKET, CARBURETOR | 1 | |
| 17 | 16223ZA0800 | GASKET, INSULATOR | 1 | |
| 18 | 16610ZE1000 | LEVER COMP., CHOKE, STD. | 1 | |
| 19* | 16953ZE1812 | LEVER, VALVE | 1 | |
| 20* | 16954ZE1811 | PLATE, LEVER SETTING | 1 | |
| 21* | 16956ZE1811 | SPRING, VALVE LEVER | 1 | |
| 22* | 16957ZE1812 | GASKET, VALVE | 1 | |
| 23* | 16967ZE0811 | CUP, FUEL STRAINER | 1 | |
| 24* | 93500030060H | SCREW, PAN 3 X 6 | 2 | |
| 25 | 9430520122 | PIN, SPRING 2 X 12 | 1 | |
| 26* | 99101ZH70820 | JET, MAIN #82, OPTIONAL | 1 | |
| 26* | 99101ZH70850 | JET, MAIN #85, OPTIONAL | 1 | |
| 26* | 99101ZH80880 | JET, MAIN #88 | 1 | |
| 27* | 99204ZE20400 | JET SET, PILOT #40 | 1 | |
| 28* | 16015ZE8005 | CHAMBER SET, FLOAT | 1 | INCLUDES ITEMS W/+ |

HONDA GX240K1HA2 ENGINE — CONTROL ASSY.

CONTROL ASSY.

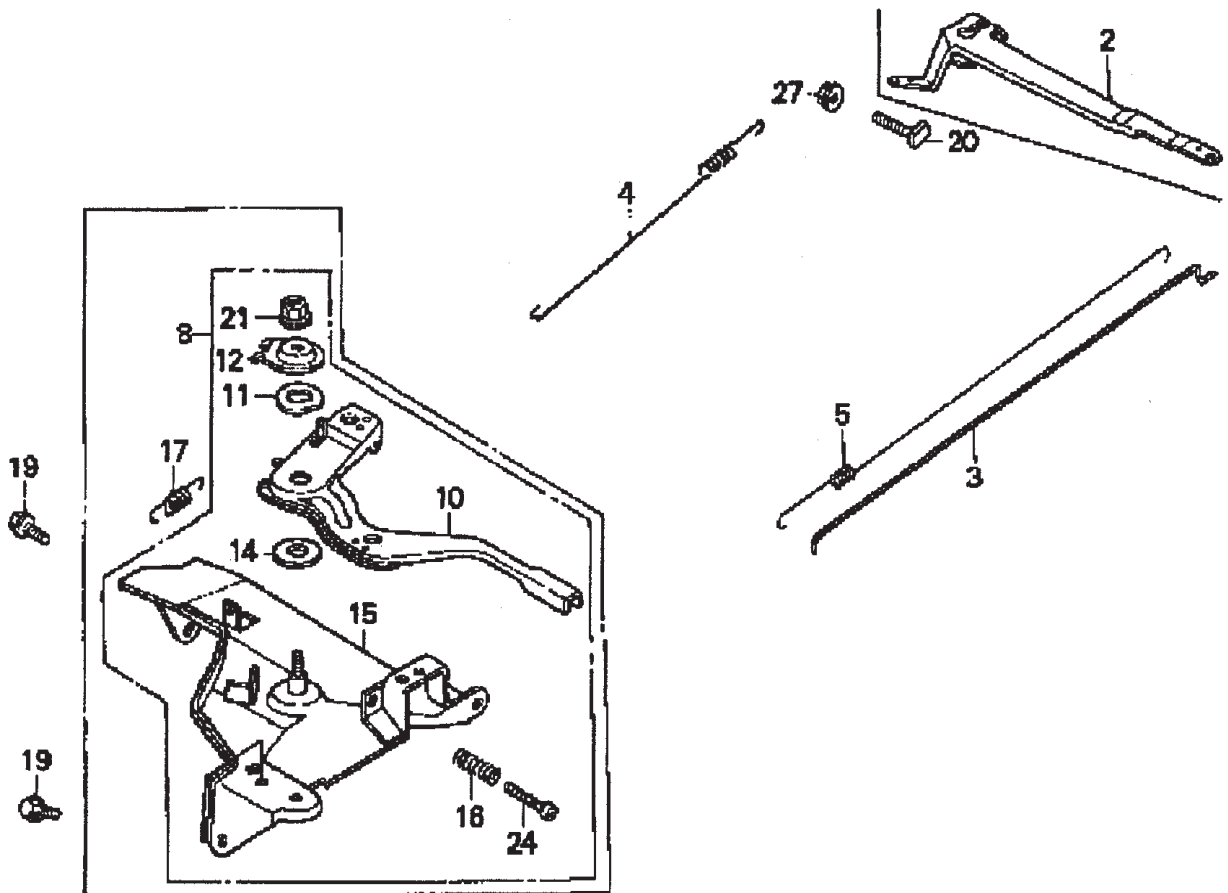

HONDA GX240K1HA2 ENGINE — CONTROL ASSY.

CONTROL ASSY.

| <u>NO.</u> | <u>PART NO.</u> | <u>PART NAME</u> | <u>QTY.</u> | <u>REMARKS</u> |
|------------|-----------------|-------------------------------|-------------|--------------------|
| 2 | 16551ZE2000 | ARM, GOVERNOR | 1 | |
| 3 | 16555ZE2000 | ROD, GOVERNOR | 1 | |
| 4 | 16561ZE2000 | SPRING, GOVERNOR | 1 | |
| 5 | 16571ZE2000 | SPRING, THROTTLE RETURN | 1 | |
| 8 | 16570ZE2W00 | CONTROL ASSEMBLY | 1 | INCLUDES ITEMS W/* |
| 10* | 16571ZE2W00 | LEVER, CONTROL | 1 | |
| 11* | 16574ZE1000 | SPRING, LEVER | 1 | |
| 12* | 16575ZE2W00 | WASHER, CONTROL LEVER | 1 | |
| 14* | 16578ZE1000 | SPACER, CONTROL LEVER | 1 | |
| 15* | 16581ZE2W00 | BASE, CONTROL | 1 | |
| 16* | 16584883300 | SPRING, CONTROL ADJUSTING | 1 | |
| 19 | 90013883000 | BOLT, FLANGE (6 X 12) (CT200) | 2 | |
| 20 | 90015ZE5010 | BOLT, GOVERNOR ARM | 1 | |
| 21* | 90114SA0000 | NUT, SELF- LOCK (6MM) | 1 | |
| 24* | 93500050280A | SCREW, PAN (5 X 28) | 1 | |
| 27 | 9405006000 | NUT, FLANGE | 1 | |

HONDA GX240K1HA2 ENGINE — CRANKCASE COVER ASSY.

CRANKCASE COVER ASSY.

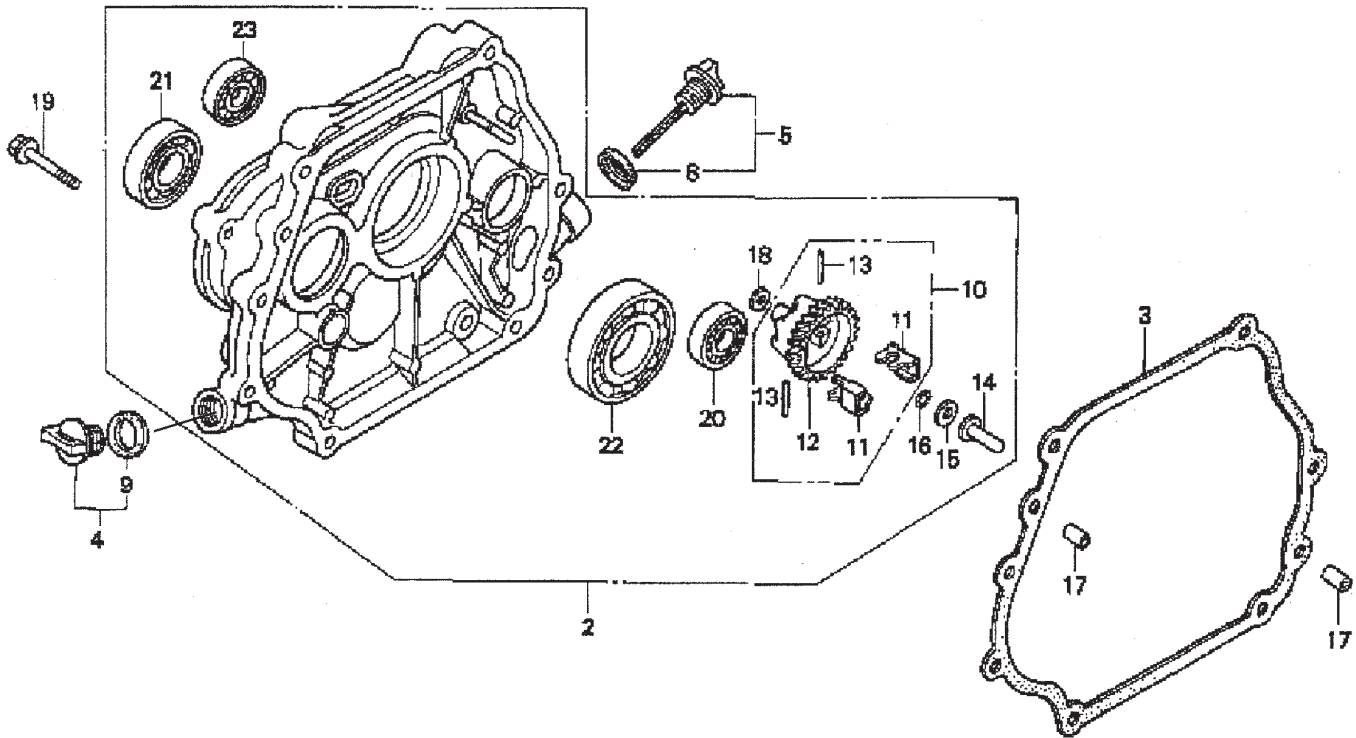

HONDA GX240K1HA2 ENGINE — CRANKCASE COVER ASSY.

CRANKCASE COVER ASSY.

| <u>NO.</u> | <u>PART NO.</u> | <u>PART NAME</u> | <u>QTY.</u> | <u>REMARKS</u> |
|------------|-----------------|---|-------------|--------------------|
| 2 | 11400ZE2621 | COVER ASSY., CRANKCASE (H-TYPE) (BALANCER) | 1 | INCLUDES ITEMS W/* |
| 3 | 11381ZE2801 | GASKET, CASE COVER | 1 | |
| 4 | 15600ZG4003 | CAP ASSY., OIL FILLER | 1 | INCLUDES ITEMS W/# |
| 5 | 15600735003 | CAP ASSY., OIL FILLER | 1 | INCLUDES ITEMS W/% |
| 8% | 15625ZE1003 | GASKET, OIL FILLER CAP | 1 | |
| 9# | 15625ZE1003 | GASKET, OIL FILLER CAP | 1 | |
| 10 | 16510ZE2811 | GOVERNOR ASSEMBLY (BALANCER) | 1 | INCLUDES ITEMS W/+ |
| 11* + | 16511ZE2000 | WEIGHT, GOVERNOR | 2 | |
| 12* + | 16512ZE2811 | HOLDER, GOVERNOR WEIGHT | 1 | |
| 13* + | 16513ZE2000 | PIN, GOVERNOR WEIGHT | 2 | |
| 14* | 16531ZE2000 | SLIDER, GOVERNOR | 1 | |
| 15* | 90473147000 | WASHER (6 X 16) | 1 | |
| 16* | 90602ZE1000 | CLIP, GOVERNOR HOLDER | 1 | |
| 17 | 90701HC4000 | PIN, DOWEL (8 X 12) | 2 | |
| 18* | 58176 | WASHER, PLAIN (6MM) | 1 | |
| 19 | 957010803500 | BOLT, FLANGE (8 X 35) | 7 | |
| 20* | 961006202000 | BEARING, RADIAL BALL (6202) | 1 | |
| 21* | 961006204000 | BEARING, RADIAL BALL (6204) | 1 | |
| 22* | 961006206000 | BEARING, RADIAL BALL (6206) | 1 | |
| 23* | 961006302000 | BEARING, RADIAL BALL (6302) | 1 | |

HONDA GX240K1HA2ENGINE — CRANKSHAFT ASSY.

CRANKSHAFT ASSY.

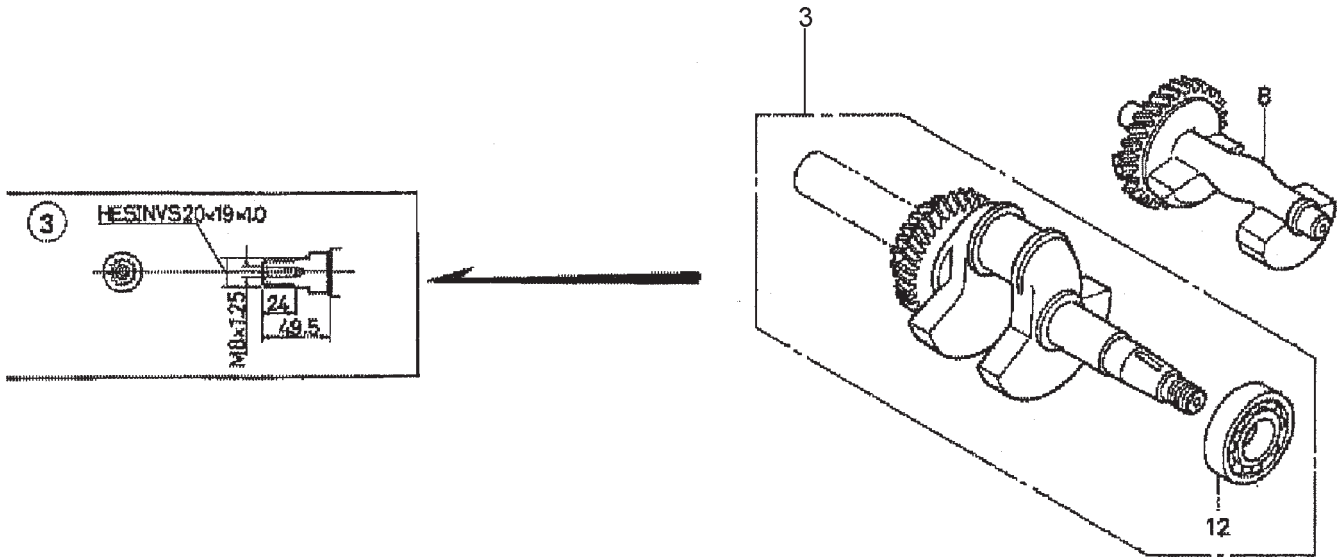

HONDA GX240K1HA2ENGINE — CRANKSHAFT ASSY.

CRANKSHAFT ASSY.

| <u>NO.</u> | <u>PART NO.</u> | <u>PART NAME</u> | <u>QTY.</u> | <u>REMARKS</u> |
|------------|-----------------|-----------------------------|-------------|-------------------|
| 3 | 13320ZE2611 | CRANKSHAFT (L- TYPE)..... | 1 | INCLUDES ITEM W/* |
| 8 | 13351ZE2010 | WEIGHT BALANCER | 1 | |
| 12* | 961006206000 | BEARING, RADIAL BALL (6206) | 1 | |

HONDA GX240K1HA2 ENGINE — CYLINDER BARREL ASSY.

CYLINDER BARREL ASSY.

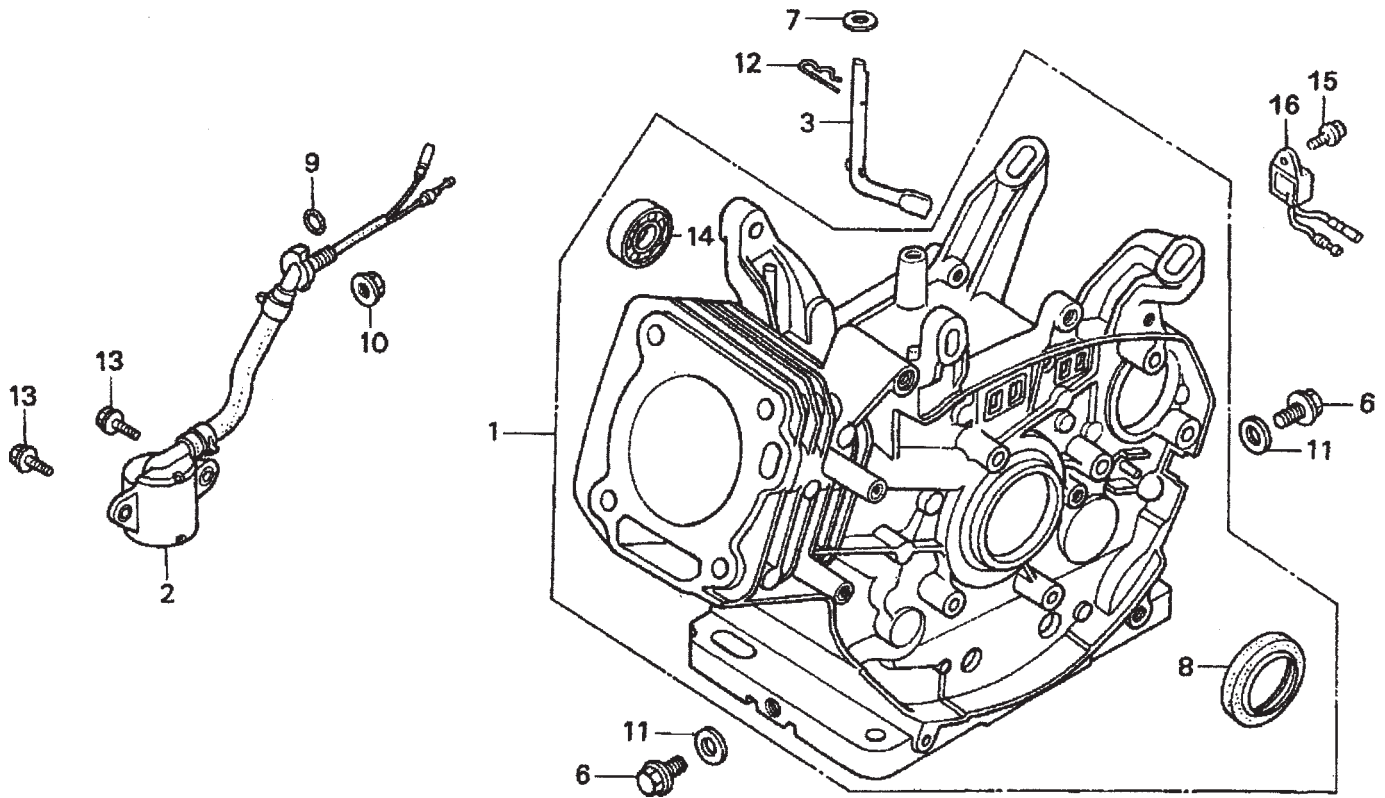

HONDA GX240K1HA2 ENGINE — CYLINDER BARREL ASSY.

CYLINDER BARREL ASSY.

| <u>NO.</u> | <u>PART NO.</u> | <u>PART NAME</u> | <u>QTY.</u> | <u>REMARKS</u> |
|------------|-----------------|--------------------------------------|-------------|--------------------|
| 1 | 12000ZE2834 | CYLINDER ASSY., BALANCER + OIL ALERT | 1 | INCLUDES ITEMS W/* |
| 2 | 15510ZE2043 | SWITCH ASSY., OIL LEVEL | 1 | |
| 3 | 16541ZE2010 | SHAFT, GOVERNOR ARM | 1 | |
| 6 | 90131896650 | BOLT, DRAIN PLUG | 2 | |
| 7 | 90446KE1000 | WASHER 8.2 X17X0.8 | 1 | |
| 8* | 91201890003 | OIL SEAL 30X46X8 | 1 | |
| 9 | 91353671003 | O-RING 14MM ARAI | 1 | |
| 10 | 9405010000 | NUT FLANGE 10MM | 1 | |
| 11 | 031112230 | WASHER, DRAIN PLUG 12MM | 2 | |
| 12 | 9425110000 | PIN, LOCK 10MM | 1 | |
| 13 | 957010601200 | BOLT, FLANGE 6X12 | 2 | |
| 14* | 961006202000 | BEARING, RADIAL BALL 6202 | 1 | |
| 15 | 90013883000 | BOLT, FLANGE 6X12 CT200 | 1 | |
| 16 | 34150ZH7003 | ALERT UNIT, OIL | 1 | |

HONDA GX240K1HA2 ENGINE — CYLINDER HEAD ASSY.

CYLINDER HEAD ASSY.

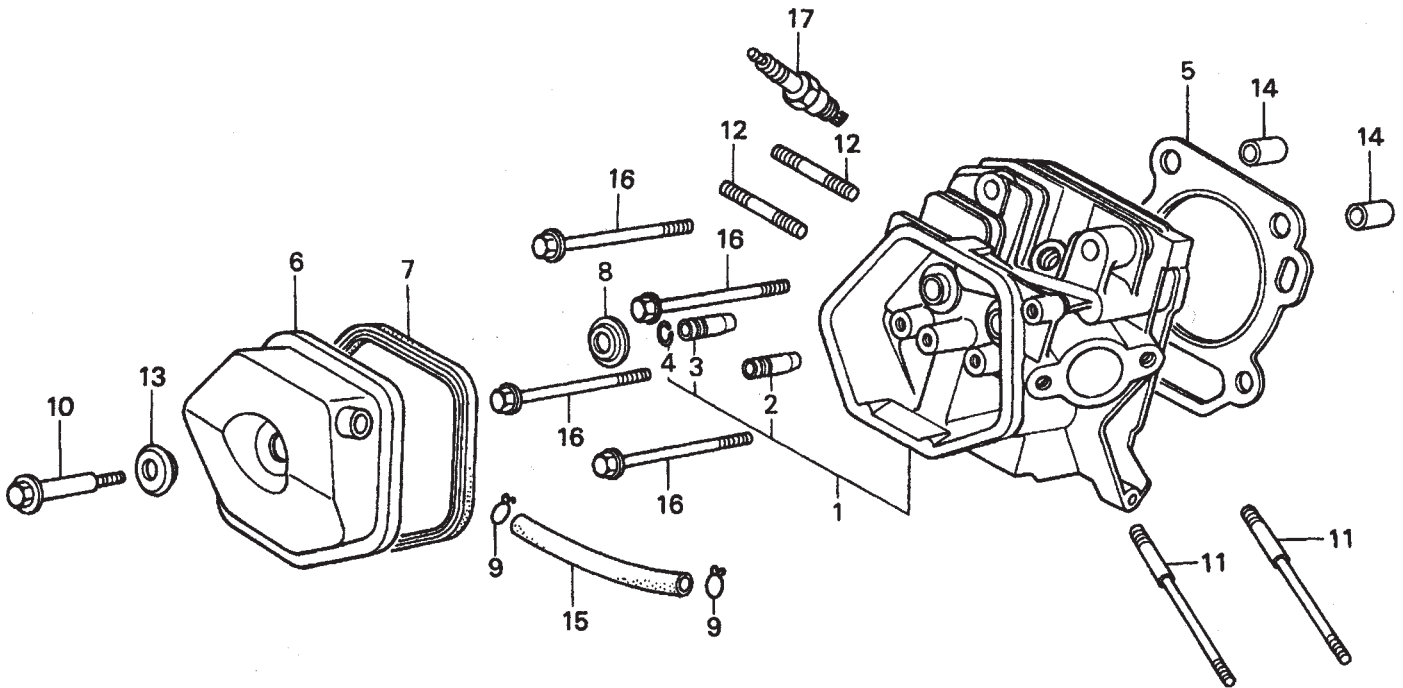

HONDA GX240K1HA2 ENGINE — CYLINDER HEAD ASSY.

CYLINDER HEAD ASSY.

| <u>NO.</u> | <u>PART NO.</u> | <u>PART NAME</u> | <u>QTY.</u> | <u>REMARKS</u> |
|------------|-----------------|-----------------------------------|-------------|--------------------|
| 1 | 12200ZH9000 | CYLINDER HEAD COMP. | 1 | INCLUDES ITEMS W/* |
| 2* | 12204ZE2306 | GUIDE, VALVE, OS, OPTIONAL | 1 | |
| 3* | 12205ZE2305 | GUIDE, EX. VALVE, OS, OPTIONAL | 1 | |
| 4* | 12216ZE2300 | CLIP, VALVE GUIDE | 1 | |
| 5 | 12251ZE2800 | GASKET, CYLINDER HEAD | 1 | |
| 6 | 12310ZE2020 | COVER COMP., HEAD | 1 | |
| 7 | 12391ZE2020 | GASKET, CYLINDER HEAD COVER | 1 | |
| 8 | 14775ZE2010 | SEAT, VALVE SPRING | 1 | |
| 10 | 90014ZE2000 | BOLT, HEAD COVER | 1 | |
| 11 | 90042ZE2000 | BOLT, STUD 8X123 | 2 | |
| 12 | 92900080320E | BOLT, STUD 8X47 | 2 | |
| 13 | 90441ZE2010 | WASHER COMP., HEAD COVER | 1 | |
| 14 | 9430112200 | PIN A, DOWEL 12X20 | 2 | |
| 15 | 950051100130M | BULK HOSE, VACUUM 11X1000, 11X100 | 1 | |
| 16 | 957011008000 | BOLT, FLANGE 10X80 | 4 | |
| 17 | 9807956846 | SPARK PLUG, BPR6ES, NGK | 1 | |
| 17 | 9807956855 | SPARK PLUG, W20EPR-U, DENSO | 1 | |

HONDA GX240K1HA2 ENGINE — FAN COVER ASSY.

FAN COVER ASSY.

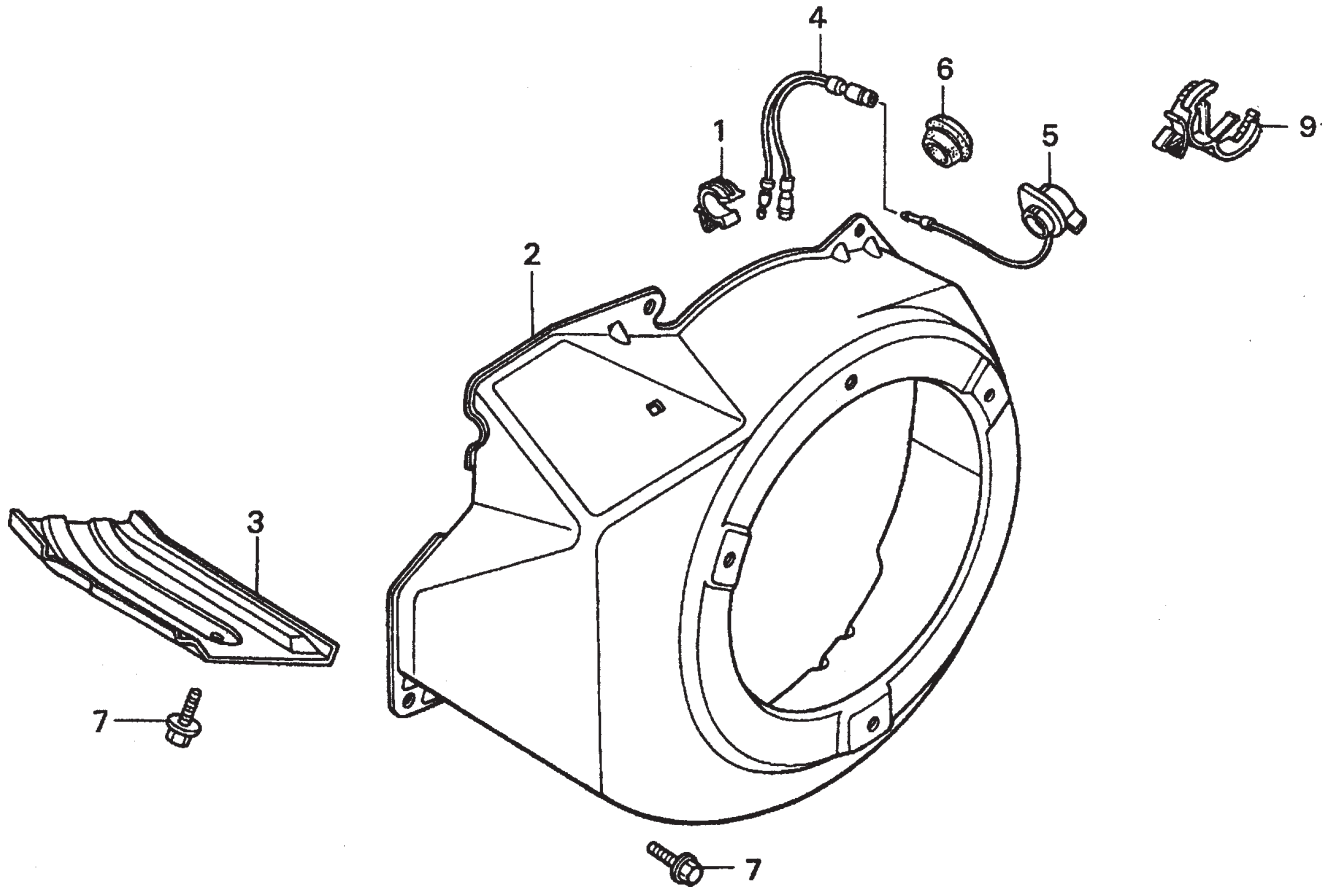

HONDA GX240K1HA2 ENGINE — FAN COVER ASSY.

FAN COVER ASSY.

| <u>NO.</u> | <u>PART NO.</u> | <u>PART NAME</u> | <u>QTY.</u> | <u>REMARKS</u> |
|------------|-----------------|------------------------------|-------------|----------------|
| 1 | 16731ZE2003 | CLIP, TUBE | 1 | |
| 2 | 19610ZE2010ZC | COVER COMP., FAN *NH1* BLACK | 1 | |
| 3 | 19631ZE2D00 | SHROUD | 1 | |
| 4 | 32197ZH8003 | SUB-HARNESS | 1 | |
| 5 | 36100ZE1015 | SWITCH ASSY., ENGINE STOP | 1 | |
| 7 | 90013883000 | BOLT, FLANGE 6X12, CT200 | 6 | |
| 9 | 90684ZA0601 | CLIP, WIRE HARNESS | 1 | |

HONDA GX240K1HA2 ENGINE — FLYWHEEL ASSY.

FLYWHEEL ASSY.

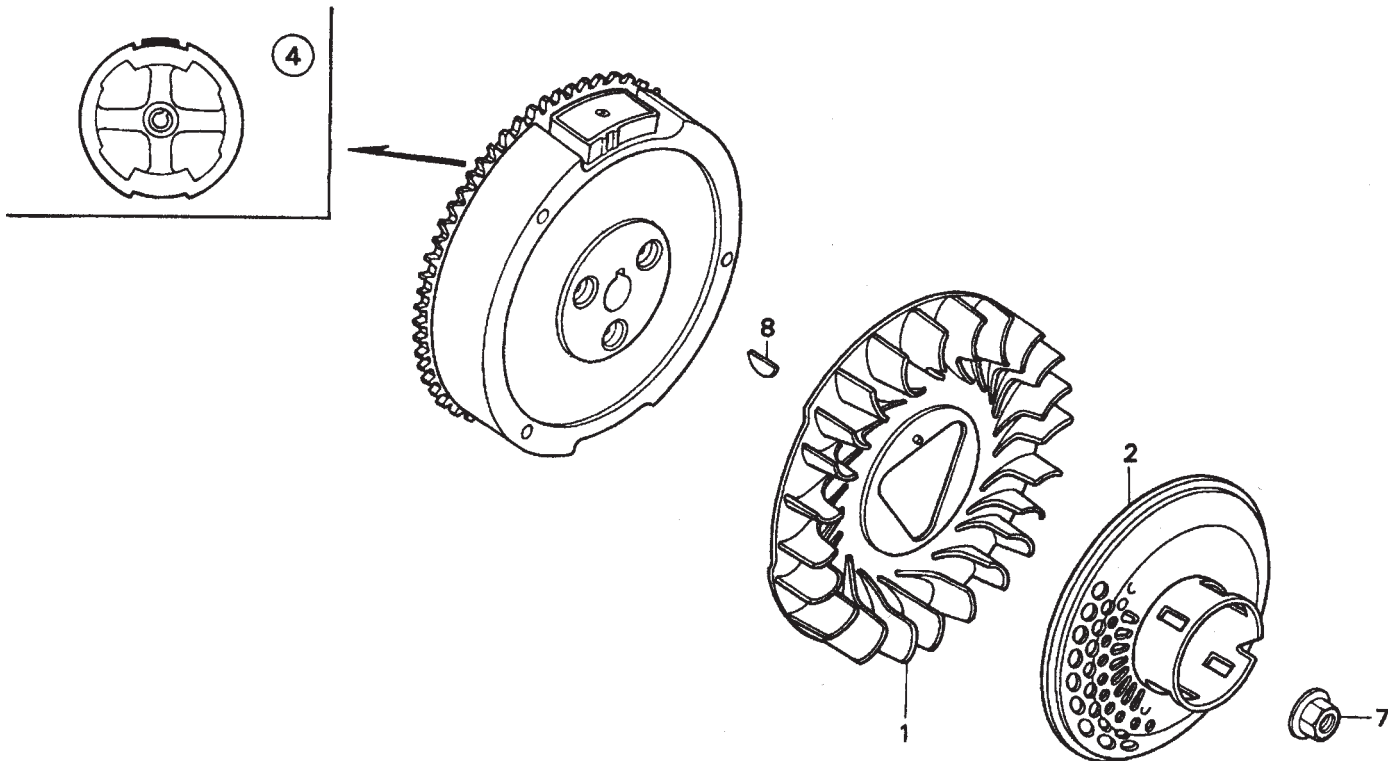

HONDA GX240K1HA2 ENGINE — FLYWHEEL ASSY.

FLYWHEEL ASSY.

| <u>NO.</u> | <u>PART NO.</u> | <u>PART NAME</u> | <u>QTY.</u> | <u>REMARKS</u> |
|------------|-----------------|------------------------------------|-------------|----------------|
| 1 | 19511ZE2000 | FAN, COOLING | 1 | |
| 2 | 28450ZE2W11 | PULLEY COMP., STARTER, SCREEN GRID | 1 | |
| 4 | 31100ZE2010 | FLYWHEEL COMP. | 1 | |
| 7 | 90201ZE3V00 | NUT, SPECIAL 16MM | 1 | |
| 8 | 90741ZE2000 | KEY, SPECIAL WOODRUFF 25X18 | 1 | |

HONDA GX240K1HA2 ENGINE — MUFFLER ASSY.

MUFFLER ASSY.

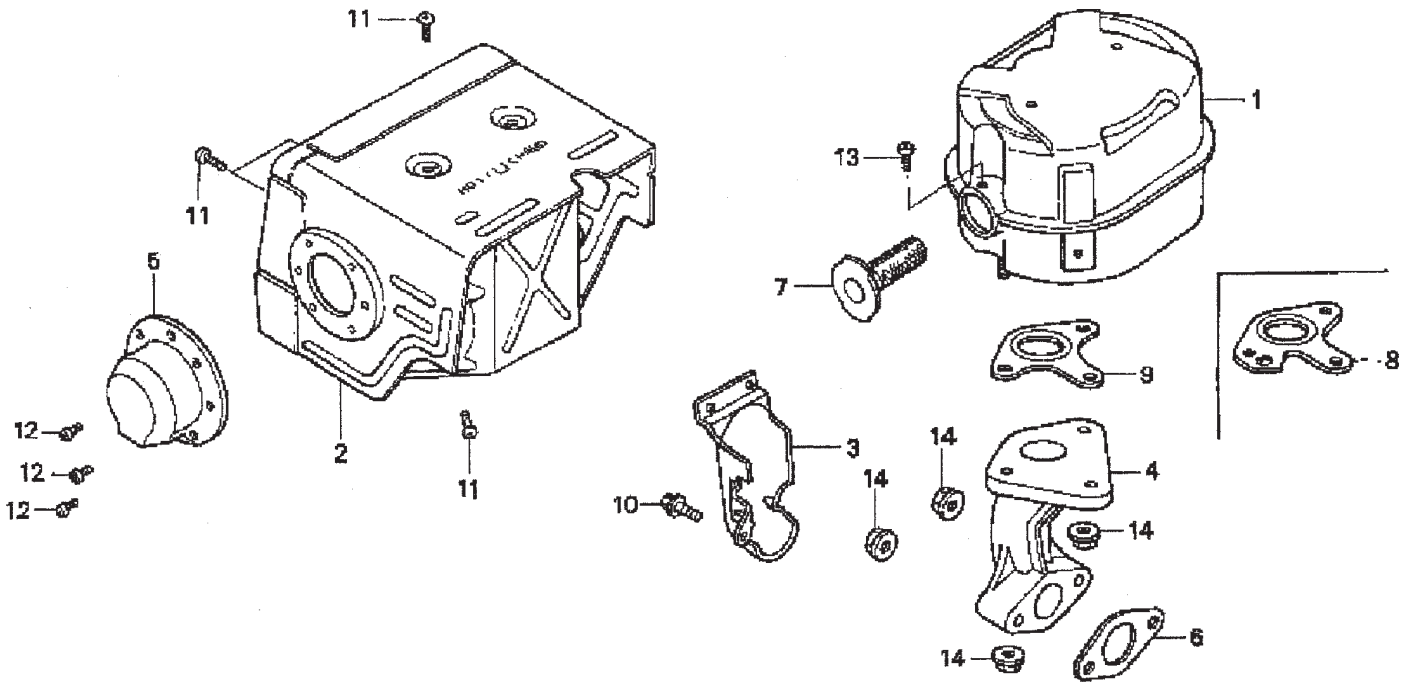

HONDA GX240K1HA2 ENGINE — MUFFLER ASSY.

MUFFLER ASSY.

| <u>NO.</u> | <u>PART NO.</u> | <u>PART NAME</u> | <u>QTY.</u> | <u>REMARKS</u> |
|------------|-----------------|-----------------------------------|-------------|----------------|
| 1 | 18310ZE2W00 | MUFFLER | 1 | |
| 2 | 18320ZE2W01 | PROTECTOR, MUFFLER | 1 | |
| 3 | 18323ZE2W00 | PROTECTOR, EX. PIPE | 1 | |
| 4 | 18330ZE2W00 | PIPE, EX. | 1 | |
| 5 | 18331ZE2810 | CAP, MUFFLER | 1 | |
| 6 | 18333ZK6Y00 | GASKET, EX. PIPE | 1 | |
| 7 | 18355ZE2010 | ARRESTER, SPARK | 1 | |
| 8 | 18381ZE2W10 | GASKET, MUFFLER (ARRESTER) | 1 | |
| 9 | 18381ZE2800 | GASKET, MUFFLER | 1 | |
| 10 | 90013883000 | BOLT, FLANGE (6 X 12) (CT200) | 1 | |
| 11 | 90050ZE1000 | SCREW, TAPPING (5 X 8) | 6 | |
| 12 | 90055ZE1000 | SCREW, TAPPING (4 X 6) | 3 | |
| 13 | 90050ZE1000 | SCREW, TAPPING (5 X 8) (OPTIONAL) | 1 | |
| 14 | 9405008000 | NUT, FLANGE (8MM) | 5 | |

HONDA GX240K1HA2 ENGINE — FUEL TANK ASSY.

FUEL TANK ASSY.

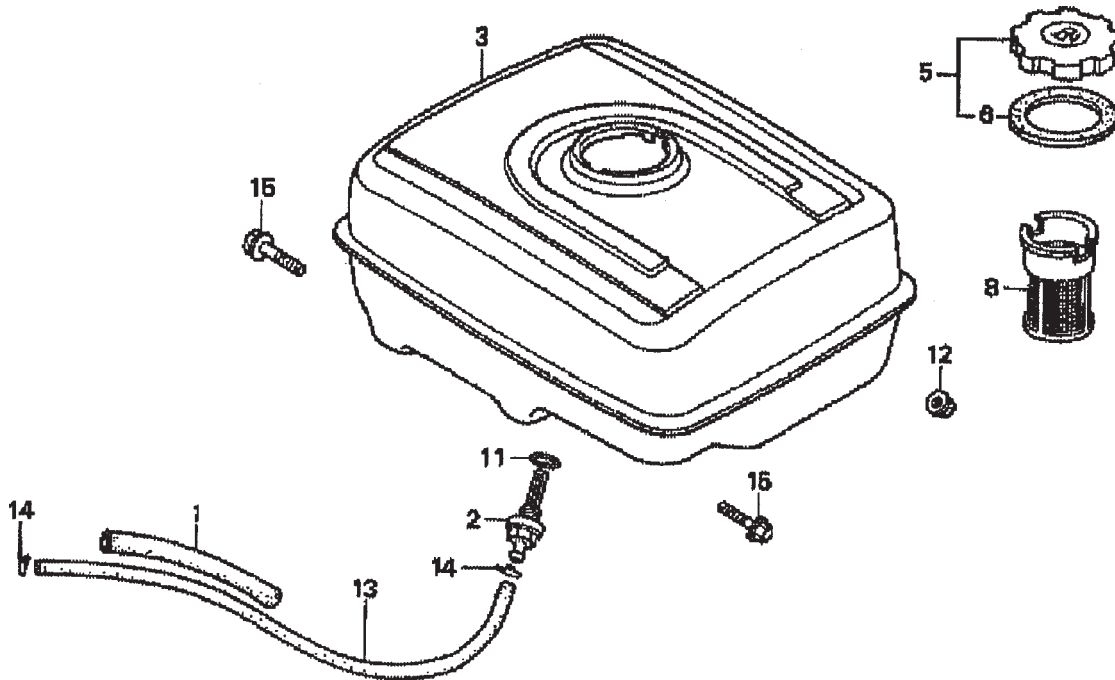

HONDA GX240K1HA2 ENGINE — FUEL TANK ASSY.

FUEL TANK ASSY.

| <u>NO.</u> | <u>PART NO.</u> | <u>PART NAME</u> | <u>QTY.</u> | <u>REMARKS</u> |
|------------|-----------------|-----------------------------------|-------------|--------------------|
| 1 | 16854ZH8000 | RUBBER SUPPORTER 107MM | 1 | |
| 2 | 16955ZE1000 | JOINT, FUEL TANK | 1 | |
| 3 | 17510ZE2010ZD | TANK COMP., FUEL *NH1*, BLACK | 1 | |
| 5 | 17620ZH7023 | CAP COMP., FUEL FILLER | 1 | INCLUDES ITEMS W/* |
| 6* | 17631ZH7003 | GASKET, FUEL FILLER CAP | 1 | |
| 8 | 17672ZE2W01 | FILTER, FUEL | 1 | |
| 11 | 91353671003 | O-RING 14MM, ARAI | 1 | |
| 12 | 9405008000 | NUT, FLANGE 8MM | 2 | |
| 13 | 950014500360M | BULK HOSE, FUEL 4.5X3000, 4.5X222 | 1 | |
| 14 | 9500202080 | CLIP, TUBE, B8 | 2 | |
| 15 | 957010802500 | BOLT, FLANGE 8X25 | 2 | |

HONDA GX240K1HA2ENGINE — IGNITION ASSY.

IGNITION COIL ASSY.

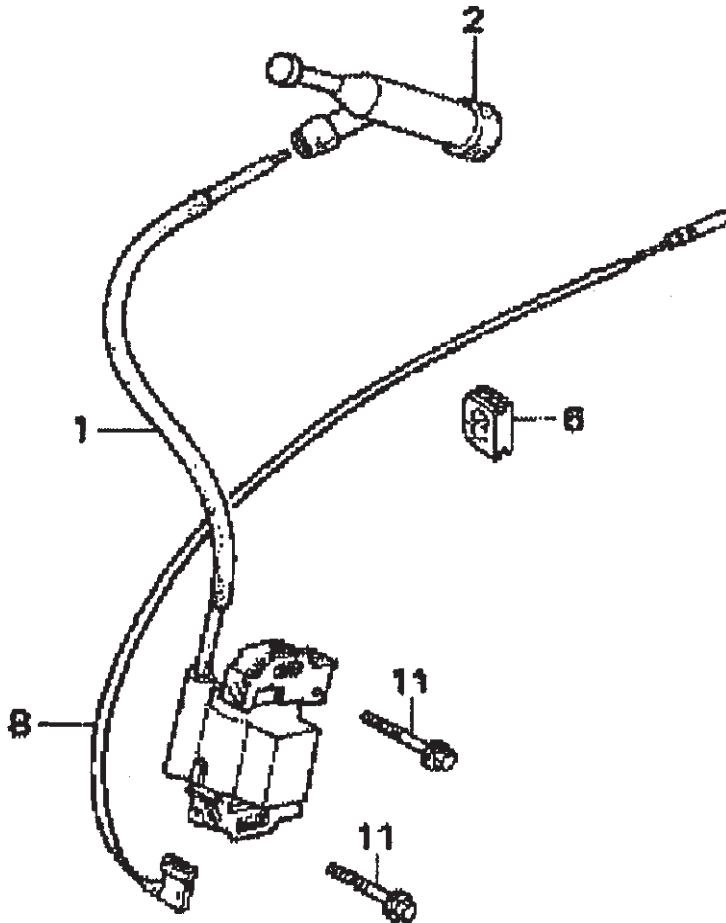

HONDA GX240K1HA2ENGINE — IGNITION ASSY.

IGNITION COIL ASSY.

| <u>NO.</u> | <u>PART NO.</u> | <u>PART NAME</u> | <u>QTY.</u> | <u>REMARKS</u> |
|------------|-----------------|-----------------------------|-------------|----------------|
| 1 | 30500ZF6W02 | COIL ASSY., IGNITION | 1 | |
| 2 | 30700ZE1013 | CAP ASSY., NOISE SUPPRESSOR | 1 | |
| 6 | 31512ZE2000 | GROMMET, WIRE | 1 | |
| 8 | 36101ZE1010 | WIRE, STOP SWITCH 370MM | 1 | |
| 11 | 90015883000 | BOLT, FLANGE 6X28 | 2 | |

HONDA GX240K1HA2 ENGINE — PISTON ASSY.

PISTON ASSY.

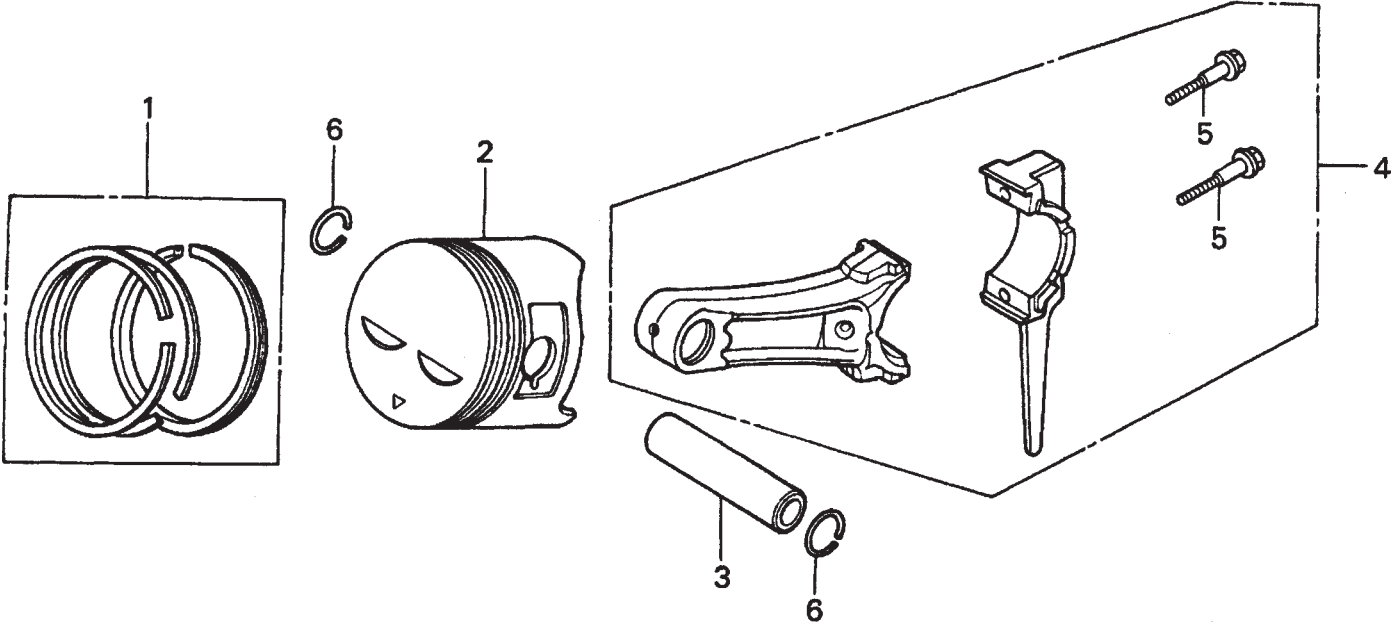

HONDA GX240K1HA2 ENGINE — PISTON ASSY.

PISTON ASSY.

| <u>NO.</u> | <u>PART NO.</u> | <u>PART NAME</u> | <u>QTY.</u> | <u>REMARKS</u> |
|------------|-----------------|--------------------------------------|-------------|--------------------|
| 1 | 13010ZE2013 | RING SET, PISTON, STD. | 1 | |
| 1 | 13011ZE2013 | RING SET, PISTON, OS 0.25, OPTIONAL | 1 | |
| 1 | 13012ZE2013 | RING SET, PISTON, OS 0.50, OPTIONAL | 1 | |
| 1 | 13013ZE2013 | RING SET, PISTON, 0.75, OPTIONAL | 1 | |
| 2 | 13101ZE2W00 | PISTON, STANDARD | 1 | |
| 2 | 13102ZE2W00 | PISTON, OS 0.25, OPTIONAL | 1 | |
| 2 | 13103ZE2W00 | PISTON, OS 0.50, OPTIONAL | 1 | |
| 2 | 13104ZE2W00 | PISTON, 0.75, OPTIONAL | 1 | |
| 3 | 13111ZE2000 | PIN, PISTON | 1 | |
| 4 | 13200ZE2000 | ROD ASSY., CONNECTING STANDARD | 1 | INCLUDES ITEMS W/* |
| 4 | 13200ZE2305 | ROD ASSY., CONNECTING, US 0.25, OPT. | 1 | |
| 5* | 90001ZE8000 | BOLT, CONNECTING ROD | 2 | |
| 6 | 90551ZE1000 | CLIP, PISTON PIN 18MM | 2 | |

HONDA GX240K1HA2 ENGINE — RECOIL STARTER ASSY.

RECOIL STARTER ASSY.

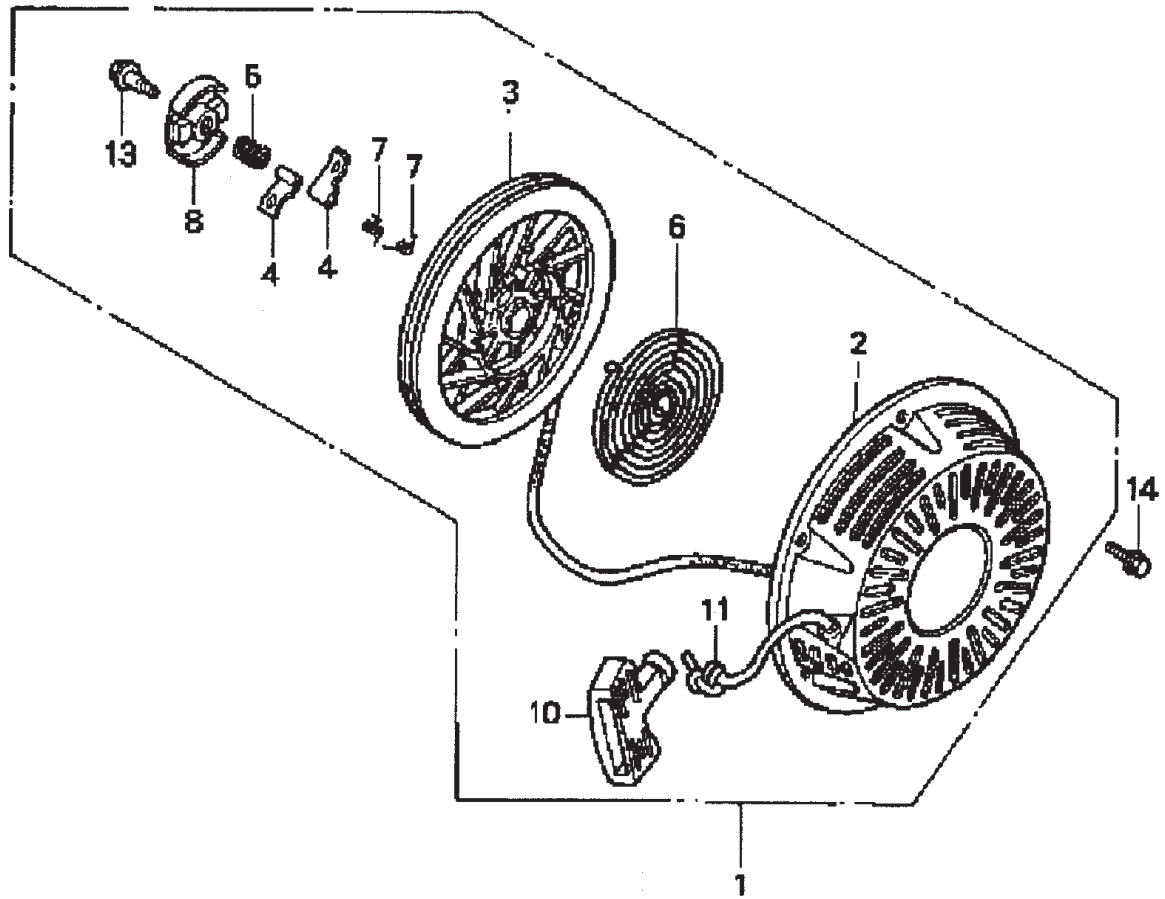

HONDA GX240K1HA2 ENGINE — RECOIL STARTER ASSY.

RECOIL STARTER ASSY.

| <u>NO.</u> | <u>PART NO.</u> | <u>PART NAME</u> | <u>QTY.</u> | <u>REMARKS</u> |
|------------|-----------------|--|-------------|--------------------|
| 1 | 28400ZE2W01ZB | STARTER ASSY., RECOIL *NH1*, BLK | 1 | INCLUDES ITEMS W/* |
| 2* | 28410ZE2W01ZB | CASE COMP., RECOIL STARTER *NH1*, BLK | 1 | |
| 3* | 28421ZE2W01 | PULLEY, RECOIL STARTER | 1 | |
| 4* | 28422ZE2W01 | RATCHET, STARTER | 2 | |
| 5* | 28441ZE2W01 | SPRING, FRICTION | 1 | |
| 6* | 28442ZE2W01 | SPRING, STARTER RETURN | 1 | |
| 7* | 28443ZE2W01 | SPRING RATCHET | 2 | |
| 8* | 28444ZE2W01 | RETAINER, SPRING | 1 | |
| 10* | 28461ZE2W02 | GRIP, STARTER | 1 | |
| 11* | 28462ZE2W11 | ROPE, RECOIL STARTER | 1 | |
| 13* | 90004ZE2W01 | SCREW, CENTER | 1 | |
| 14 | 90008ZE2003 | BOLT, FLANGE 6X10 | 3 | |

HONDA GX240K1HA2 ENGINE — GEAR REDUCTION ASSY.

GEAR REDUCTION ASSY.

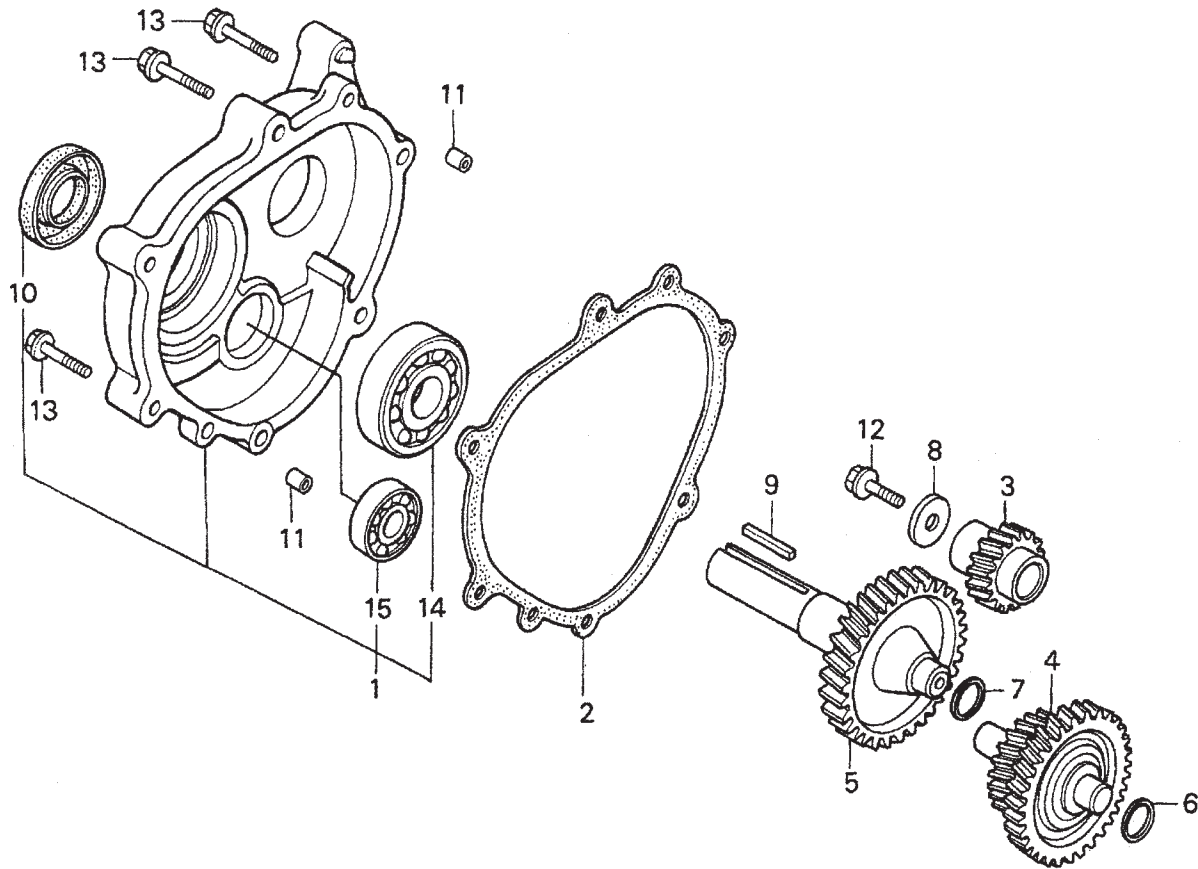

HONDA GX240K1HA2 ENGINE — GEAR REDUCTION ASSY.

GEAR REDUCTION ASSY.

| <u>NO.</u> | <u>PART NO.</u> | <u>PART NAME</u> | <u>QTY.</u> | <u>REMARKS</u> |
|------------|-----------------|----------------------------------|-------------|--------------------|
| 1 | 11500ZE2620 | COVER ASSY, REDUCTION CASE | 1 | INCLUDES ITEMS W/* |
| 2 | 11521ZE2800 | GASKET, CHAIN CASE COVER | 1 | |
| 3 | 22103ZE2620 | GEAR, PRIMARY DRIVE (17T) | 1 | |
| 4 | 23220ZE2621 | COUNTERSHAFT | 1 | |
| 5 | 23710ZE2621 | SHAFT, P.T.O. (H- TYPE) | 1 | |
| 6 | 90401ZE2620 | SHIM A (OPTIONAL) | AR | |
| 7 | 90402ZE2620 | SHIM B (OPTIONAL) | AR | |
| 8 | 90473842000 | WASHER (8MM) | 1 | |
| 9 | 90745ZE2600 | KEY (6.3 X 6.3 X 43) | 1 | |
| 10* | 91201890003 | OIL SEAL (30 X 46 X 8) | 1 | |
| 11 | 9430108140 | PIN A, DOWEL (8 X 14) | 2 | |
| 12 | 957010802500 | BOLT, FLANGE (8 X 25) | 1 | |
| 13 | 957010804000 | BOLT, FLANGE (8 X 40) | 6 | |
| 14* | 961006206000 | BEARING, RADIAL BALL (6206) | 1 | |
| 15* | 961006302000 | BEARING, RADIAL BALL (6302) | 1 | |

HONDA GX240K1HA2 ENGINE — LABEL ASSY.

LABEL ASSY.

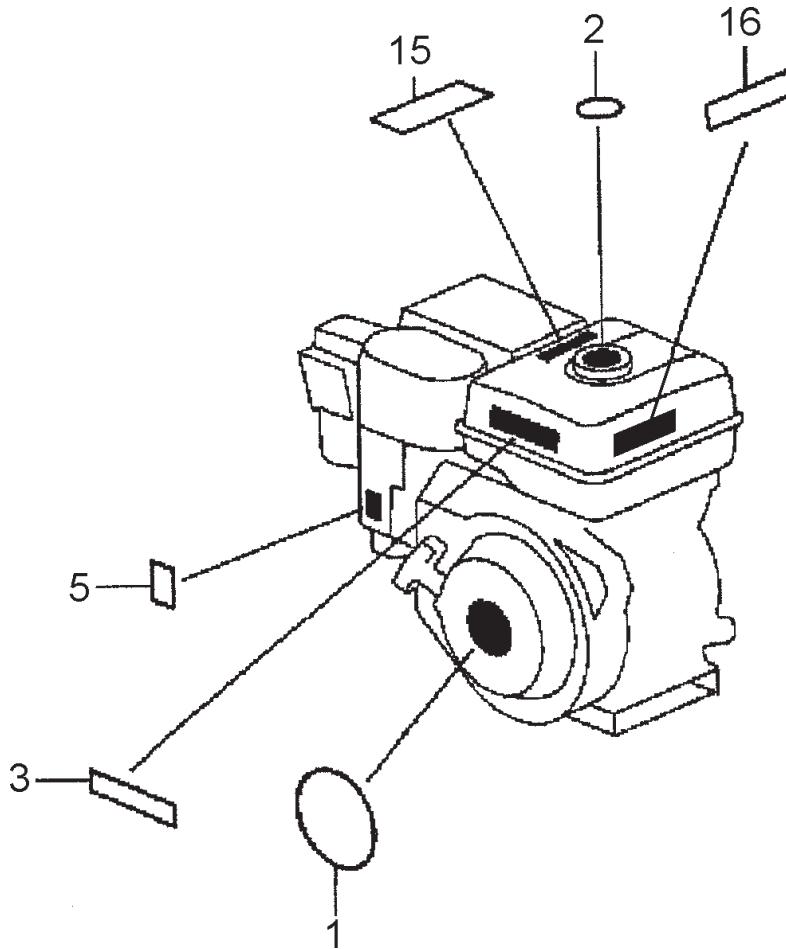

HONDA GX240K1HA2 ENGINE — LABEL ASSY.

LABELS ASSY.

| <u>NO.</u> | <u>PART NO.</u> | <u>PART NAME</u> | <u>QTY.</u> | <u>REMARKS</u> |
|------------|-----------------|-------------------------|-------------|----------------|
| 1 | 87521ZE2W01 | EMBLEM, INTERNAL | 1 | |
| 2 | 87522ZE1810 | MARK, CAUTION, EXTERNAL | 1 | |
| 3 | 87522ZH9000 | LABEL, CAUTION | 1 | |
| 5 | 87528ZE2810 | MARK, CHOKE, EXTERNAL | 1 | |
| 15 | 87586ZH7W00 | LABEL, FUEL CAUTION | 1 | |
| 16 | 87532ZH8810 | MARK, OIL ALERT | 1 | |

PAYMENT TERMS

Terms of payment for parts are net 30 days.

FREIGHT POLICY

All parts orders will be shipped collect or prepaid with the charges added to the invoice. All shipments are F.O.B. point of origin. Multiquip's responsibility ceases when a signed manifest has been obtained from the carrier, and any claim for shortage or damage must be settled between the consignee and the carrier.

MINIMUM ORDER

The minimum charge for orders from Multiquip is \$15.00 net. Customers will be asked for instructions regarding handling of orders not meeting this requirement.

RETURNED GOODS POLICY

Return shipments will be accepted and credit will be allowed, subject to the following provisions:

1. A Returned Material Authorization must be approved by Multiquip prior to shipment.
2. To obtain a Return Material Authorization, a list must be provided to Multiquip Parts Sales that defines item numbers, quantities, and descriptions of the items to be returned.
 - a. The parts numbers and descriptions must match the current parts price list.
 - b. The list must be typed or computer generated.
 - c. The list must state the reason(s) for the return.
 - d. The list must reference the sales order(s) or invoice(s) under which the items were originally purchased.
 - e. The list must include the name and phone number of the person requesting the RMA.
3. A copy of the Return Material Authorization must accompany the return shipment.
4. Freight is at the sender's expense. All parts must be returned freight prepaid to

5. Parts must be in new and resalable condition, in the original Multiquip package (if any), and with Multiquip part numbers clearly marked.
6. The following items are not returnable:
 - a. Obsolete parts. (If an item is in the price book and shows as being replaced by another item, it is obsolete.)
 - b. Any parts with a limited shelf life (such as gaskets, seals, "O" rings, and other rubber parts) that were purchased more than six months prior to the return date.
 - c. Any line item with an extended dealer net price of less than \$5.00.
 - d. Special order items.
 - e. Electrical components.
 - f. Paint, chemicals, and lubricants.
 - g. Decals and paper products.
 - h. Items purchased in kits.
7. The sender will be notified of any material received that is not acceptable.
8. Such material will be held for five working days from notification, pending instructions. If a reply is not received within five days, the material will be returned to the sender at his expense.
9. Credit on returned parts will be issued at dealer net price at time of the original purchase, less a 15% restocking charge.
10. In cases where an item is accepted, for which the original purchase document can not be determined, the price will be based on the list price that was effective twelve months prior to the RMA date.
11. Credit issued will be applied to future purchases only.

PRICING AND REBATES

Prices are subject to change without prior notice. Price changes are effective on a specific date and all orders received on or after that date will be billed at the revised price. Rebates for price declines and added charges for price increases will not be made for stock on hand at the time of any price change.

Multiquip reserves the right to quote and sell direct to Government agencies, and to Original Equipment Manufacturer accounts who use our products as integral parts of their own products.

SPECIAL EXPEDITING SERVICE

A \$35.00 surcharge will be added to the invoice for special handling including bus shipments, insured parcel post or in cases where Multiquip must personally deliver the parts to the carrier.

LIMITATIONS OF SELLER'S LIABILITY

Multiquip shall not be liable hereunder for damages in excess of the purchase price of the item with respect to which damages are claimed, and in no event shall Multiquip be liable for loss of profit or good will or for any other special, consequential or incidental damages.

LIMITATION OF WARRANTIES

No warranties, express or implied, are made in connection with the sale of parts or trade accessories nor as to any engine not manufactured by Multiquip. Such warranties made in connection with the sale of new, complete units are made exclusively by a statement of warranty packaged with such units, and Multiquip neither assumes nor authorizes any person to assume for it any other obligation or liability whatever in connection with the sale of its products. Apart from such written statement of warranty, there are no warranties, express, implied or statutory, which extend beyond the description of the products on the face hereof.

OPERATION AND PARTS MANUAL

HERE'S HOW TO GET HELP

PLEASE HAVE THE MODEL AND SERIAL
NUMBER *ON-HAND* WHEN CALLING

UNITED STATES

Multiquip Corporate Office

18910 Wilmington Ave. Tel. (800) 421-1244
Carson, CA 90746 Fax (800) 537-3927
Contact: mq@multiquip.com

Mayco Parts

800-306-2926 Fax: 800-672-7877
310-537-3700 Fax: 310-637-3284

Service Department

800-421-1244 Fax: 310-537-4259
310-537-3700

MQ Parts Department

800-427-1244 Fax: 800-672-7877
310-537-3700 Fax: 310-637-3284

Warranty Department

800-421-1244, Ext. 279 Fax: 310-537-1173
310-537-3700, Ext. 279

Technical Assistance

800-478-1244 Fax: 310-631-5032

MEXICO

MQ Cipsa

Carr. Fed. Mexico-Puebla KM 126.5 Tel: (52) 222-225-9900
Momoxpan, Cholula, Puebla 72760 Mexico Fax: (52) 222-285-0420
Contact: pmastretta@cipsa.com.mx

CANADA

Multiquip

4110 Industriel Boul. Tel: (450) 625-2244
Laval, Quebec, Canada H7L 6V3 Fax: (450) 625-8664
Contact: jmartin@multiquip.com

UNITED KINGDOM

Multiquip (UK) Limited Head Office

Hanover Mill, Fitzroy Street, Tel: 0161 339 2223
Ashton-under-Lyne, Fax: 0161 339 3226
Lancashire OL7 0TL
Contact: sales@multiquip.co.uk

BRAZIL

Multiquip

Av. Evandro Lins e Silva, 840 - grupo 505 Tel: 011-55-21-3433-9055
Barra de Tijuca - Rio de Janeiro Fax: 011-55-21-3433-9055
Contact: cnavarro@multiquip.com.br, srentes@multiquip.com.br

© COPYRIGHT 2006, MULTIQUIP INC.

Multiquip Inc, the MQ logo and the Essick logo are registered trademarks of Multiquip Inc. and may not be used, reproduced, or altered without written permission. All other trademarks are the property of their respective owners and used with permission.

This manual MUST accompany the equipment at all times. This manual is considered a permanent part of the equipment and should remain with the unit if resold.

The information and specifications included in this publication were in effect at the time of approval for printing. Illustrations are based on the *MQ Essick EC92S-P Concrete Mixer*. Illustrations, descriptions, references and technical data contained in this manual are for guidance only and may not be considered as binding. Multiquip Inc. reserves the right to discontinue or change specifications, design or the information published in this publication at any time without notice and without incurring any obligations.

Your Local Dealer is:

