

PARTS MANUAL



MODELS

MP2050E1

MP2050E3

MP2090HP

MASONRY SAWS

(5 HP 1Ø ELECTRIC MOTOR)

(5 HP 3Ø ELECTRIC MOTOR)

(9.0 HP GASOLINE ENGINE)

Revision #9 (03/29/10)

To find the latest revision of this
publication, visit our website at:
www.multiquip.com



THIS MANUAL MUST ACCOMPANY THE EQUIPMENT AT ALL TIMES.

P/N 35304



CALIFORNIA — Proposition 65 Warning

Engine exhaust and some of its constituents, and some dust created by power sanding, sawing, grinding, drilling and other construction activities contains chemicals known to the State of California to cause cancer, birth defects and other reproductive harm.

Some examples of these chemicals are:

- Lead from lead-based paints.
- Crystalline silica from bricks.
- Cement and other masonry products.
- Arsenic and chromium from chemically treated lumber.

Your risk from these exposures varies, depending on how often you do this type of work. To reduce your exposure to these chemicals: **ALWAYS** work in a well ventilated area, and work with approved safety equipment, such as dust masks that are specially designed to filter out microscopic particles.

WARNING



SILICOSIS WARNING

Grinding/cutting/drilling of masonry, concrete, metal and other materials with silica in their composition may give off dust or mists containing crystalline silica. Silica is a basic component of sand, quartz, brick clay, granite and numerous other minerals and rocks. Repeated and/or substantial inhalation of airborne crystalline silica can cause serious or fatal respiratory diseases, including silicosis. In addition, California and some other authorities have listed respirable crystalline silica as a substance known to cause cancer. When cutting such materials, always follow the respiratory precautions mentioned above.

WARNING



RESPIRATORY HAZARDS

Grinding/cutting/drilling of masonry, concrete, metal and other materials can generate dust, mists and fumes containing chemicals known to cause serious or fatal injury or illness, such as respiratory disease, cancer, birth defects or other reproductive harm. If you are unfamiliar with the risks associated with the particular process and/or material being cut or the composition of the tool being used, review the material safety data sheet and/or consult your employer, the material manufacturer/supplier, governmental agencies such as OSHA and NIOSH and other sources on hazardous materials. California and some other authorities, for instance, have published lists of substances known to cause cancer, reproductive toxicity, or other harmful effects.

Control dust, mist and fumes at the source where possible. In this regard use good work practices and follow the recommendations of the manufacturers or suppliers, OSHA/NIOSH, and occupational and trade associations. Water should be used for dust suppression when wet cutting is feasible. When the hazards from inhalation of dust, mists and fumes cannot be eliminated, the operator and any bystanders should always wear a respirator approved by NIOSH/MSHA for the materials being used.

MP2 “MASON PRO” SAW — TABLE OF CONTENTS

MP2 “MASON PRO” MASONRY SAW

Proposition 65 Warning	2
Silicosis/Respiratory Warnings	3
Table Of Contents	4
Parts Ordering Procedures	5
Explanation of Codes in Remarks	6
Suggested Spare Parts	7

COMPONENT DRAWINGS

Nameplate and Decals	8-9
Tray Assembly	10-11
Cart Assembly	12-13
Motor Plate and Blade Guard Assembly	14-15
Electric Motor Assembly	16-17
Water Pump Assembly (Electric Motors Only)	18-19
Gasoline Engine Mount Assy.	20-21
Gasoline Engine Jackshaft Assy.	22-23
Gasoline Engine Covers Assy.	24-25
Water Pump Assembly (Gasoline Engines Only) ..	26-27
Step Pedal Assembly	28-29

HONDA GX270QWH2 GASOLINE ENGINE

Air Cleaner (Cyclone) Assembly	30-31
Camshaft Assembly	32-33
Carburetor Assembly	34-35
Control Assembly	36-37
Crankcase Cover Assembly	38-39
Crankshaft Assembly	40-41
Cylinder Barrel Assembly	42-43
Cylinder Head Assembly	44-45
Fan Cover Assembly	46-47
Flywheel Assembly	48-49
Fuel Tank Assembly	50-51
Ignition Coil Assembly	52-53
Labels Assembly	54-55
Muffler Assembly	56-57
Piston Assembly	58-59
Recoil Starter Assembly	60-61

Terms and Conditions of Sale — Parts	62
--	----



Specification and part number are subject to change without notice.

PARTS ORDERING PROCEDURES

Ordering parts has never been easier! Choose from three easy options:

Effective:
January 1st, 2006

www.multiquip.com



Order via Internet (Dealers Only):

Order parts on-line using Multiquip's SmartEquip website!

- View Parts Diagrams
- Order Parts
- Print Specification Information



If you have an MQ Account, to obtain a Username and Password, E-mail us at: parts@multiquip.com.

To obtain an MQ Account, contact your District Sales Manager for more information.

Goto www.multiquip.com and click on **Order Parts** to log in and save!

Use the **internet** and qualify for a **5% Discount** on *Standard orders* for all orders which include complete part numbers.*

Note: Discounts Are Subject To Change



Order via Fax (Dealers Only):

All customers are welcome to order parts via Fax.

Domestic (US) Customers dial:
1-800-6-PARTS-7 (800-672-7877)

Fax your order in and qualify for a **2% Discount** on *Standard orders* for all orders which include complete part numbers.*

Note: Discounts Are Subject To Change



Order via Phone: Domestic (US) Dealers Call:
1-800-427-1244

Non-Dealer Customers:

Contact your local Multiquip Dealer for parts or call 800-427-1244 for help in locating a dealer near you.



International Customers should contact their local Multiquip Representatives for Parts Ordering information.

When ordering parts, please supply:

- | | |
|---|--|
| <input type="checkbox"/> Dealer Account Number | <input type="checkbox"/> Specify Preferred Method of Shipment: |
| <input type="checkbox"/> Dealer Name and Address | <input checked="" type="checkbox"/> UPS/Fed Ex <input checked="" type="checkbox"/> DHL |
| <input type="checkbox"/> Shipping Address (if different than billing address) | <input type="checkbox"/> Priority One <input checked="" type="checkbox"/> Truck |
| <input type="checkbox"/> Return Fax Number | <input type="checkbox"/> Ground |
| <input type="checkbox"/> Applicable Model Number | <input type="checkbox"/> Next Day |
| <input type="checkbox"/> Quantity, Part Number and Description of Each Part | <input type="checkbox"/> Second/Third Day |

NOTICE

All orders are treated as *Standard Orders* and will ship the same day if received prior to 3PM PST.

WE ACCEPT ALL MAJOR CREDIT CARDS!



MP2 “MASON PRO” SAW — EXPLANATION OF CODE IN REMARKS

The following section explains the different symbols and remarks used in the Parts section of this manual. Use the help numbers found on the back page of the manual if there are any questions.

NOTICE

The contents and part numbers listed in the parts section are subject to change **without notice**. Multiquip does not guarantee the availability of the parts listed.

SAMPLE PARTS LIST

NO.	PART NO.	PART NAME	QTY.	REMARKS
1	12345	BOLT.....	1	INCLUDES ITEMS W/%
2%		WASHER, 1/4 IN.....		NOT SOLD SEPARATELY
2%	12347	WASHER, 3/8 IN....	1	MQ-45T ONLY
3	12348	HOSE	A/R	MAKE LOCALLY
4	12349	BEARING	1	S/N 2345B AND ABOVE

NO. Column

Unique Symbols — All items with same unique symbol

(@, #, +, %, or >) in the number column belong to the same assembly or kit, which is indicated by a note in the “Remarks” column.

Duplicate Item Numbers — Duplicate numbers indicate multiple part numbers, which are in effect for the same general item, such as different size saw blade guards in use or a part that has been updated on newer versions of the same machine.

NOTICE

When ordering a part that has more than one item number listed, check the remarks column for help in determining the proper part to order.

PART NO. Column

Numbers Used — Part numbers can be indicated by a number, a blank entry, or TBD.

TBD (To Be Determined) is generally used to show a part that has not been assigned a formal part number at the time of publication.

A blank entry generally indicates that the item is not sold separately or is not sold by Multiquip. Other entries will be clarified in the “Remarks” Column.

QTY. Column

Numbers Used — Item quantity can be indicated by a number, a blank entry, or A/R.

A/R (As Required) is generally used for hoses or other parts that are sold in bulk and cut to length.

A blank entry generally indicates that the item is not sold separately. Other entries will be clarified in the “Remarks” Column.

REMARKS Column

Some of the most common notes found in the “Remarks” Column are listed below. Other additional notes needed to describe the item can also be shown.

Assembly/Kit — All items on the parts list with the same unique symbol will be included when this item is purchased.

Indicated by:

“INCLUDES ITEMS W/(unique symbol)”

Serial Number Break — Used to list an effective serial number range where a particular part is used.

Indicated by:

“S/N XXXXX AND BELOW”

“S/N XXXX AND ABOVE”

“S/N XXXX TO S/N XXX”

Specific Model Number Use — Indicates that the part is used only with the specific model number or model number variant listed. It can also be used to show a part is NOT used on a specific model or model number variant.

Indicated by:

“XXXXX ONLY”

“NOT USED ON XXXX”

“Make/Obtain Locally” — Indicates that the part can be purchased at any hardware shop or made out of available items. Examples include battery cables, shims, and certain washers and nuts.

“Not Sold Separately” — Indicates that an item cannot be purchased as a separate item and is either part of an assembly/kit that can be purchased, or is not available for sale through Multiquip.

MP2 "MASON PRO" SAW — SUGGESTED SPARE PARTS

MP2 "MASON PRO" SAW 1 TO 3 UNITS *Electric Motor Models*

Qty.	P/N	Description
2	20478	KNOB, COMFORT GRIP
1	23783-001	WRENCH, HEX 3/4
4	21004-005	V-BELT, ELECTRIC MOTOR AX-48
1	23843-001	WATER PUMP, ELECTRIC MOTOR
4 FT.	23867-006	VINYL WATERTUBING
1	27036-501	CONVEYOR CART ASSY.
2	23830-001	BLADE SHAFT BEARING
2	8136	BLADE SCREW
2	5054 A	WASHER, LOCK
2	23832-001	OUTER BLADE FLANGE
2	23833-001	INNER BLADE FLANGE
2	18637-001	HANDLE LOCK

MP2 "MASON PRO" SAW 1 TO 3 UNITS *Gasoline Engine Model*

Qty.	P/N	Description
2	20478	HANDLE GRIP
2	23830-001	BLADE SHAFT BEARING
2	8136	BLADE SCREW
2	5054 A	WASHER, LOCK
1	23783-001	WRENCH, HEX 3/4
4	16779-012	V-BELT, DRIVE, 3VX250
4	16779-004	V-BELT, JACK SHAFT 3VX375
1	25685-001	STRAINER
1	27036-501	CONVEYOR CART ASSY.
2	23833-001	OUTER BLADE FLANGE
2	23846-001	INNER BLADE FLANGE
2	18637-001	KNOB, LOCK
3	17210ZE1505	ELEMENT, AIR CLEANER
3	9807956846	SPARK PLUG
1	17620ZH7023	CAP, FUEL FILLER
1	28462ZE2W11	ROPE, RECOIL STARTER

MP2 "MASON PRO" SAW — NAME PLATE AND DECALS

NAMEPLATE AND DECALS

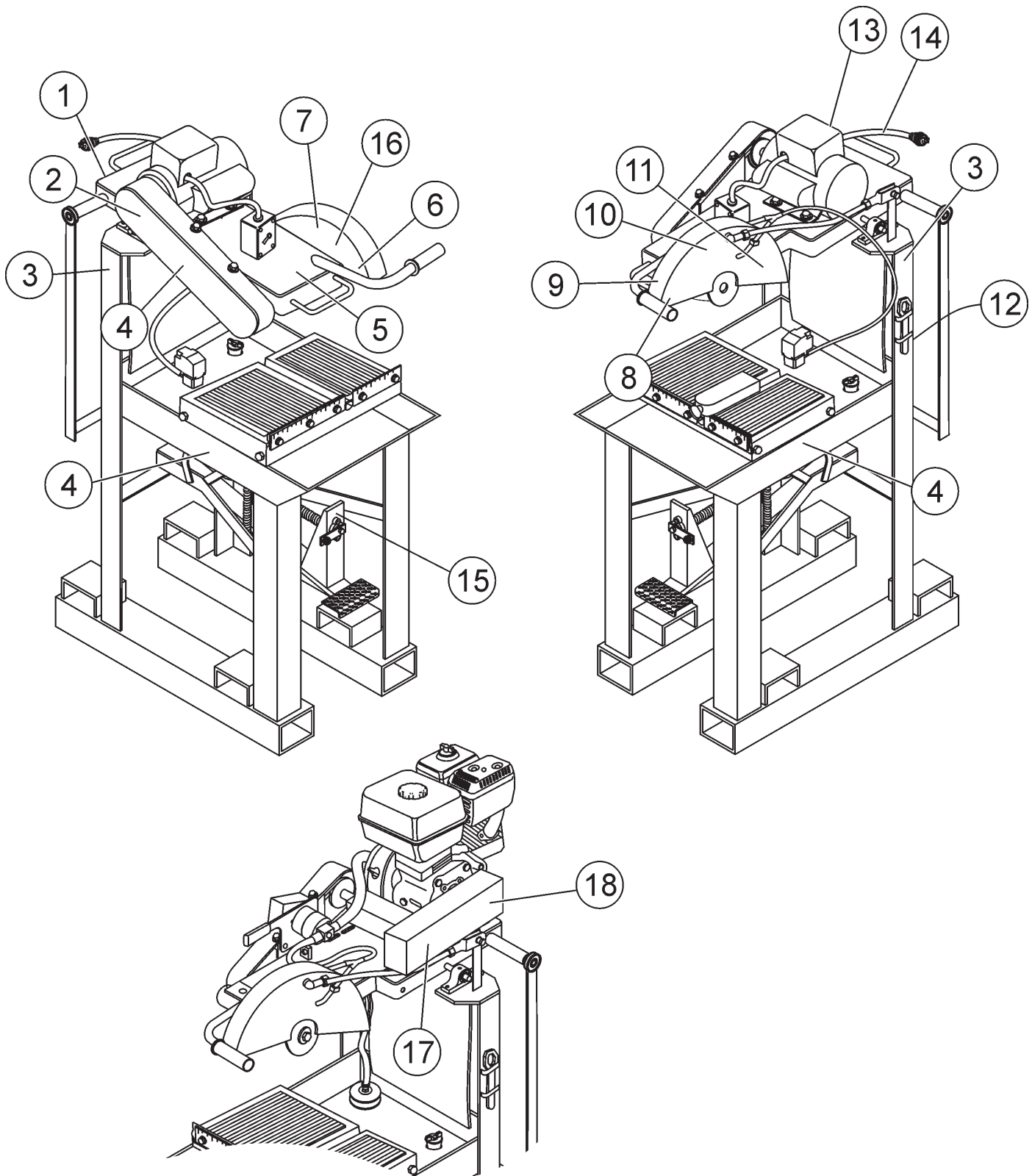

GASOLINE MODELS ONLY

MP2 “MASON PRO” SAW — NAME PLATE AND DECALS

NAMEPLATE AND DECALS

<u>NO.</u>	<u>PART NO.</u>	<u>PART NAME</u>	<u>QTY.</u>	<u>REMARKS</u>
1		PLATE, MODEL/SERIAL NUMBER	1	CONTACT PARTS DEPT.
2	21302	DECAL, BELT GUARD WARNING	1	
3	25781	DECAL, MQ DIAMONDBACK 2 x 2 IN.	2	
4	25788	DECAL, MP2 MASON SAW LOGO	3	
5	15580	DECAL, RESPIRATORY WARNING	1	
6	35137	DECAL, READ OPERATORS MANUAL	1	
7	25491	DECAL, CW ROTATION	1	
8	25249-001	DECAL, BLADE WARNING	1	
9	22122-001	DECAL, PREVENT SERIOUS INJURY	1	
10	29730	DECAL, US FLAG	1	
11	25782	DECAL, MQ DIAMONDBACK 4 x 4 IN.	1	
12	13118	DECAL, POWDER COATED	1	
13	25139-001	DECAL, EXTENSION CORD SIZE	1	ELECTRIC MODELS ONLY
14	25215-001	DECAL, ELECTRIC CORD WARNING	1	ELECTRIC MODELS ONLY
15	27082-001	DECAL, CRANK HANDLE TURN DIRECTION	1	
16	20525	DECAL, PROP 65	1	
17	25788	DECAL, MP2 MASON SAW LOGO	1	GASONLINE MODELS ONLY
18	21302	DECAL, BELT GUARD WARNING	1	GASONLINE MODELS ONLY

MP2 "MASON PRO" SAW — TRAY ASSY.

TRAY ASSY.

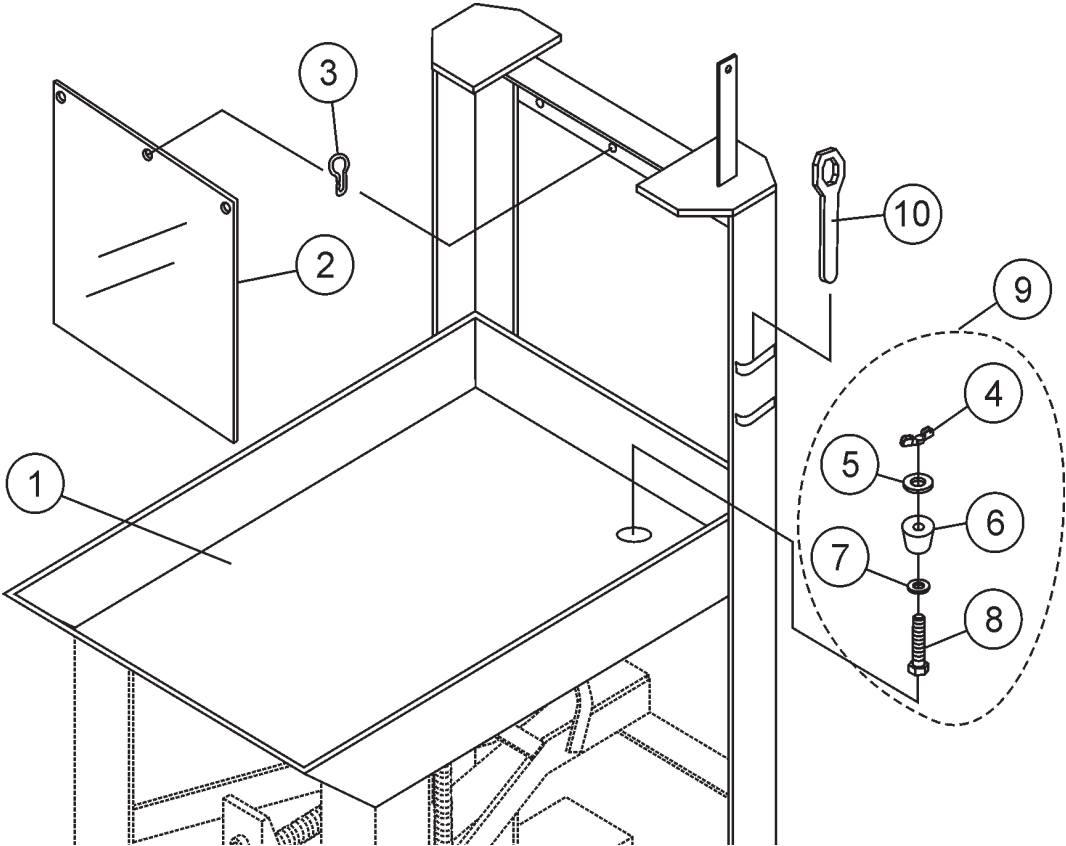

MP2 "MASON PRO" SAW — TRAY ASSY.

TRAY ASSY.

<u>NO.</u>	<u>PART NO.</u>	<u>PART NAME</u>	<u>QTY.</u>	<u>REMARKS</u>
1	26963-751	FRAME	1	RED
2	27026-001	CURTAIN, SPLASH	1	
3	23853-001	SNAP HOOK, SHOWER CURTAIN	3	
4*	2509	NUT, WING 1/4 - 20 PLTD	1	
5*	12391-004	WASHER, FLAT 1/4 AN970-4	1	
6*	23847-001	RUBBER STOPPER	1	
7*	0948	WASHER, FLAT SAE 1/4	1	
8*	5277	SCREW, HHC 1/4 - 20 X 1-1/2	1	
9	23862-501	RUBBER STOPPER ASSY.	1	INCLUDES ITEMS W/*
10	23783-001	WRENCH, HEX 3/4	1	

MP2 "MASON PRO" SAW — CART ASSY.

CART ASSY.

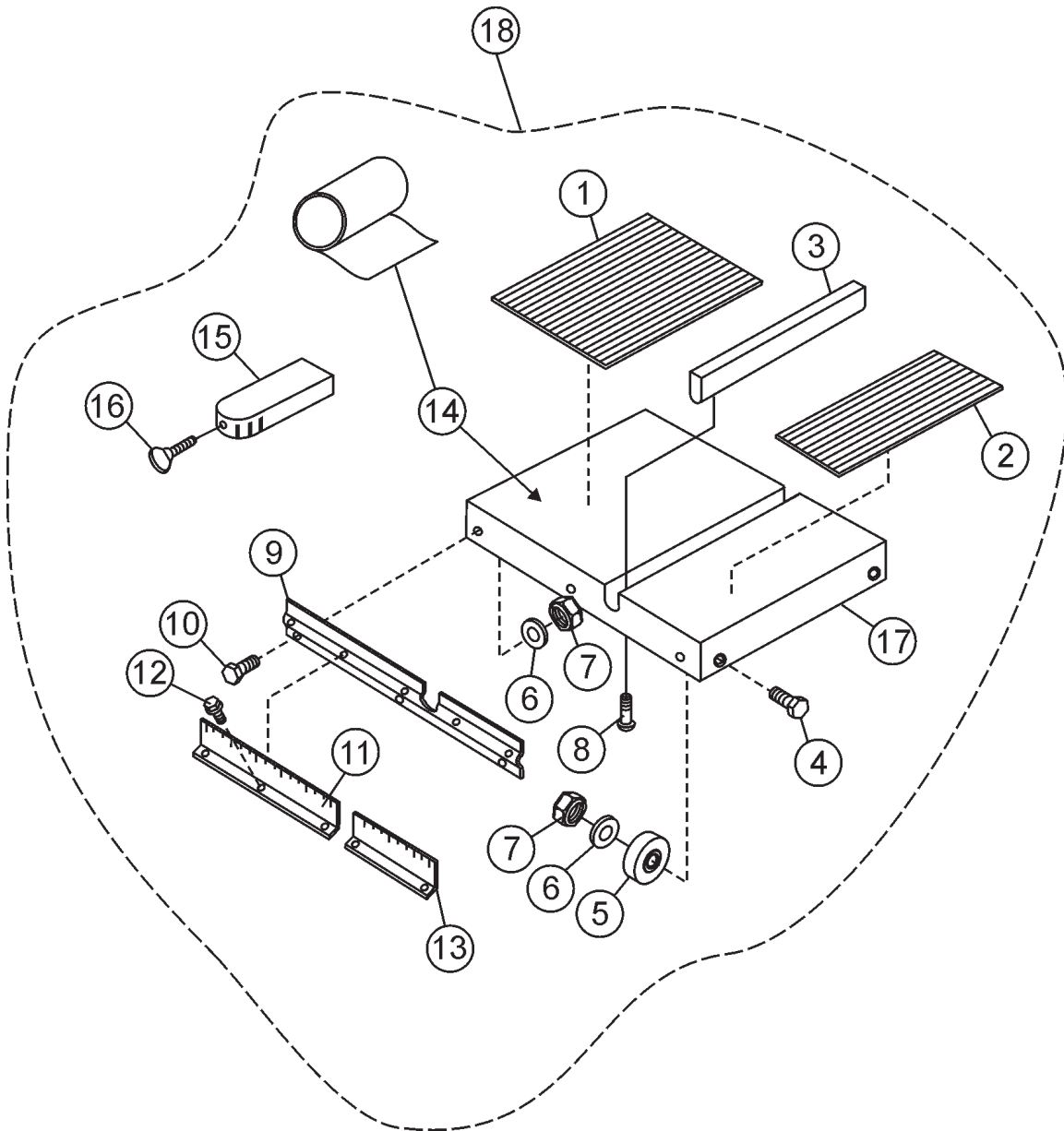

MP2 "MASON PRO" SAW — CART ASSY.

CART ASSY.

<u>NO.</u>	<u>PART NO.</u>	<u>PART NAME</u>	<u>QTY.</u>	<u>REMARKS</u>
1*	23804-003	MAT, RUBBER V-RIB 6.75 X 12.06 IN.	1	
2*	23804-004	MAT, RUBBER V-RIB 14.94 X 12.06 IN.	1	
3*	27035-001	INSERT, CONVEYOR CART	1	
4*	0730	SCREW, HHC 1/4-20 X 1 IN.	4	
5*	23793-001	WHEEL, CONVEYOR CART	4	
6*	0948	WASHER, FLAT	4	
7*	08233-004	NUT, LOCK 1/4 IN. - 20 GRIPCO	7	
8*	23796-001	SCREW, RD HD	2	
9*	27037-001	SIDE CONVEYOR	1	
10*	23866-001	SCREW, HHST, 10-32 x 1/2 IN.	5	
11*	27032-001	RULER, LONG SIDE	1	
12*	23795-008	SCREW, HHST	5	
13*	27033-001	RULER, SHORT	1	
14*	26076-301	TAPE, ROLL ADHESIVE TRNSFR	8.5 FT.	
15*	24288-001	GUIDE, CUTTING	1	
16*	08622-012	SCREW, THUMB 5/16 - 18 X 1-1/2 IN.	1	
17*	26992-351	CART, CONVEYOR	1	
18	27036-501	CART ASSEMBLY	1	INCLUDES ITEMS W/*

MP2 "MASON PRO" SAW — MOTOR PLATE & BLADE GUARD ASSY.

MOTOR PLATE & BLADE GUARD ASSY.

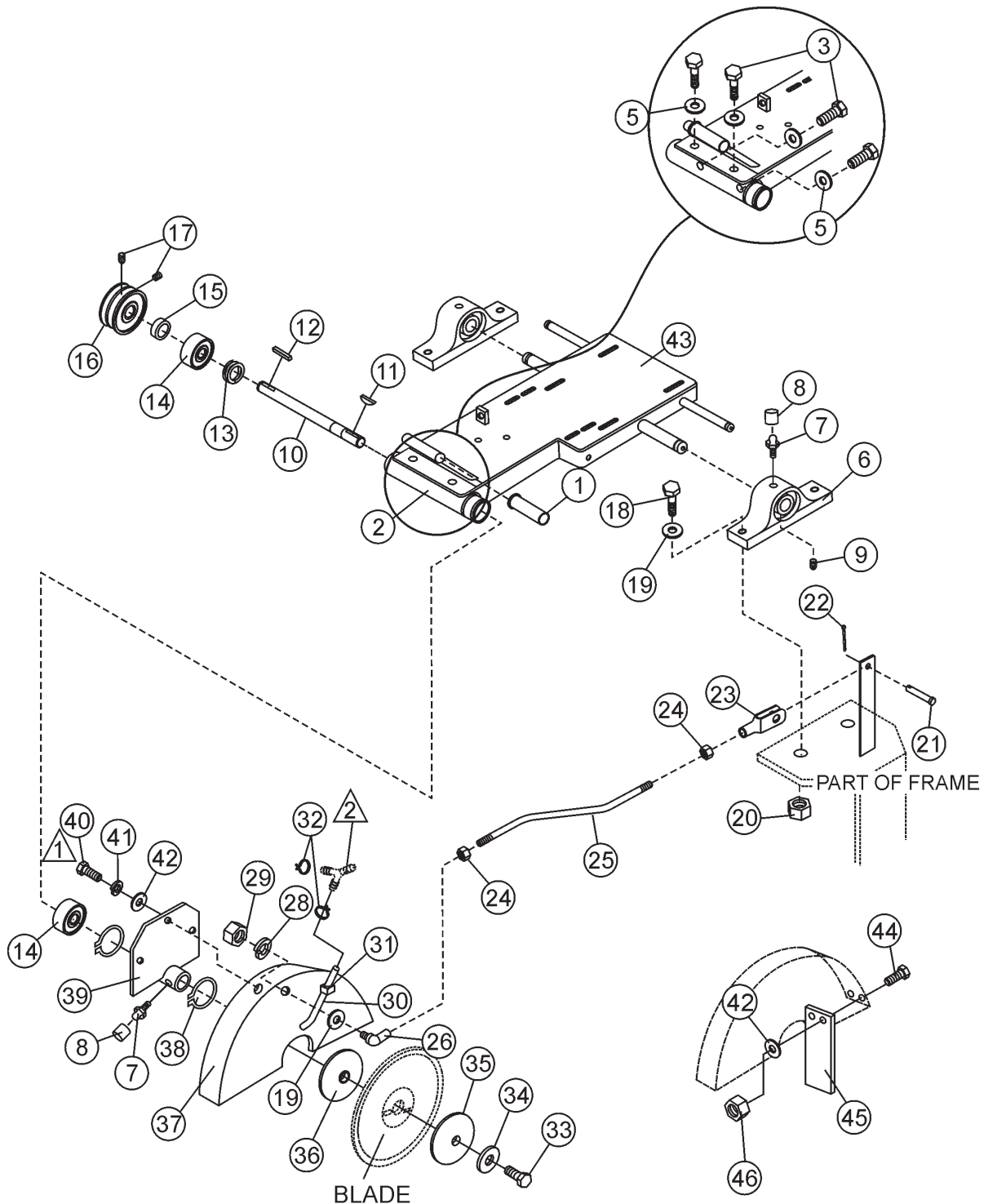

NOTES:

- ▲ USE THREADLOCK COMPOUND LOC-TITE 271 OR EQUIVALENT.
- ▲ WATER PUMP ASSY. (ELECTRIC MOTORS ONLY), ITEM 5

MP2 "MASON PRO" SAW — MOTOR PLATE & BLADE GUARD ASSY.

MOTOR PLATE & BLADE GUARD ASSY.

<u>NO.</u>	<u>PART NO.</u>	<u>PART NAME</u>	<u>QTY.</u>	<u>REMARKS</u>
1	20478	GRIP, HANDLE	1	
2	23835-702	TUBE, SPINDLE ASSY.	1	
3	16105	SCREW, HEX 5/16-24 x 3/4 IN.	4	
5	0300 B	WASHER, FLAT 5/16 IN.	4	
6	27023-001	BEARING, PILLOW BLOCK	2	INCLUDES ITEMS W/#
7	2621	ZERK FITTING	3	
8	1162 A	CAP, GREASE ZERK #2 YLW	3	
9#	TBD	SET SCREW, PILLOW BLOCK	4	
10	23834-003	SHAFT, SPINDLE	1	
11	07011-017	KEY, WOODRUFF KEY	1	
12	0627	KEY, SQUARE 3/16 x 1-1/4 IN.	1	
13	06330-006	WASHER, SPRING	1	
14	23830-001	BEARING	2	
15	23829-002	SPACER, 1/2"	1	S/N YG55003339 AND BELOW
15	23829-001	SPACER, 1/4"	1	S/N YG55003340 AND ABOVE
16	27030-001	PULLEY, SPINDLE	1	ELECTRIC MODELS ONLY
16	28324-001	PULLEY, SPINDLE	1	GASOLINE MODELS ONLY
17	10138	SET SCREW, SPINDLE PULLEY	3	
18	1284	SCREW, HEX 3/8-16 x 1-1/2 IN.	4	
19	10136	WASHER, FLAT 3/8 IN.	5	
20	10133	NUT, GRIPPO 3/8-16 IN.	4	
21	5291	PIN, CLEVIS 3/8 x 1-1/8 IN.	1	
22	0683	PIN, COTTER 3/32 DIA. x 3/4 IN.	1	
23	08327-012	YOKE END, ADJUSTABLE	1	
24	2199	NUT, JAM 3/8-24 IN.	2	
25	27021-001	TIE ROD	1	
26	27034-001	BALL JOINT, QUICK DISCONNECT	1	
28	0166 A	WASHER, LOCK 3/8 IN.	1	
29	07037-006	NUT, HEX 3/8-24 IN.	1	
30	23867-005	TUBING, VINYL	2	
31	25628-001	HOSE CLAMP, BLADE GUARD	2	
32	12694-001	HOSE CLAMP	2	
33	8136	BOLT, HEX 1/2-20 x 1-1/2 IN.	1	
34	5054 A	WASHER, LOCK	1	
35	23832-001	OUTER FLANGE	1	
36	23833-001	INNER FLANGE	1	
37	27008-751	BLADE GUARD ASSY.	1	RED
38	17510-002	SNAP RING	2	
39	23825-351	MOUNTING PLATE, BLADE GUARD	1	
40	0131 A	SCREW, HEX 1/4-20 x 3/4 IN.	3	
41	0181 B	WASHER, LOCK 1/4 IN.	5	
42	0948	WASHER, FLAT 1/4 IN.	3	
43	26984-751	MOTOR PLATE	1	RED
43	29003-751	MOTOR PLATE	1	9 HP HONDA
44	0131 A	SCREW, HHC 1/4-20 x 3/4 IN.	2	
45	27078-001	SPLASH SHIELD, BLADE GUARD	1	
46	0949	NUT, HEX 1/4-20 IN.	2	

MP2 "MASON PRO" SAW — ELECTRIC MOTOR

ELECTRIC MOTOR

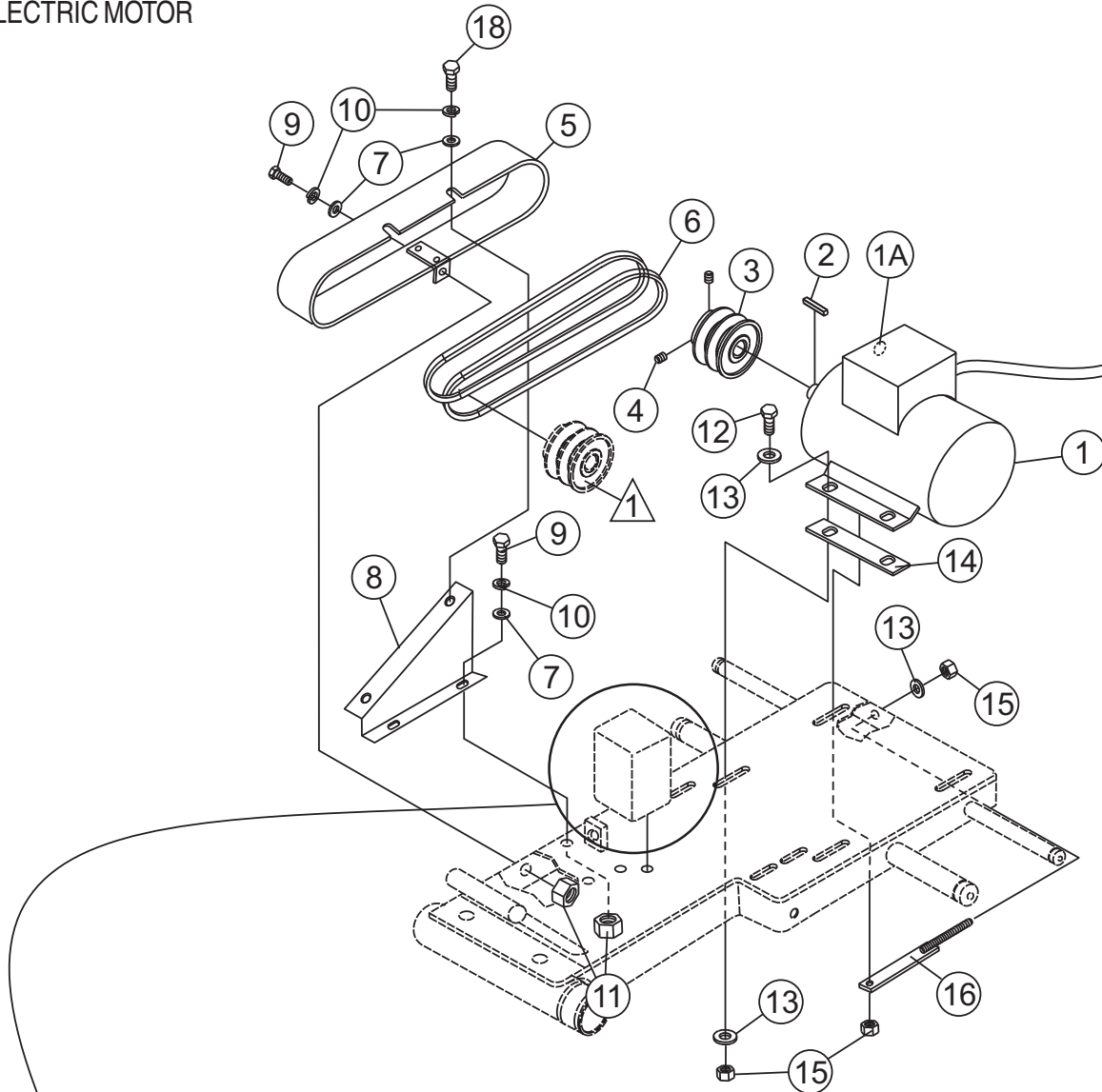

SINGLE PHASE SWITCH

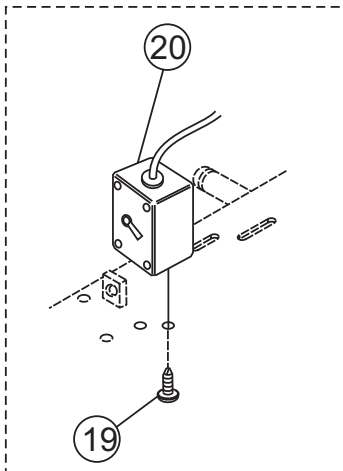

THREE PHASE SWITCH

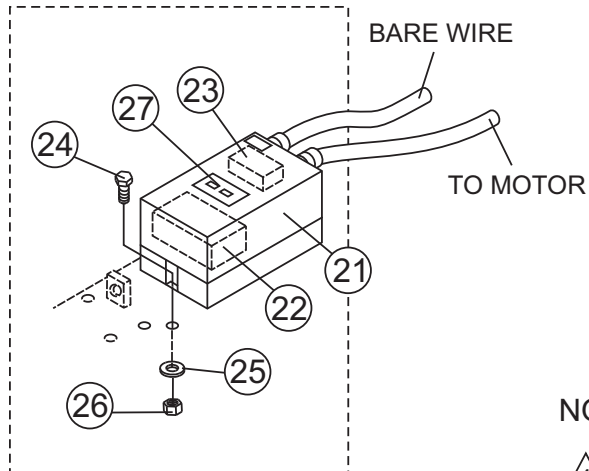

NOTES:

 MOTOR PLATE & BLADE GUARD ASSY., ITEM 16

MP2 "MASON PRO" SAW — ELECTRIC MOTOR

ELECTRIC MOTOR

<u>NO.</u>	<u>PART NO.</u>	<u>PART NAME</u>	<u>QTY.</u>	<u>REMARKS</u>
1	27022-401	ELECTRIC MOTOR, 5 HP 1Ø	1	INCLUDES ITEMS W/*
1	27090-401	ELECTRIC MOTOR, 5 HP 3Ø	1	INCLUDES ITEMS W/*
2*	6059 B	KEY, 1/4 x 2	2	
3	27029-001	PULLEY (MOTOR)	1	
4	16193-006	SCREW, SHS 5/16-18 x 3/8 IN.	2	
5	27002-751	BELT GUARD	1	
6	21004-005	BELT - AX-48	2	
7	0948	WASHER, FLAT 1/4	5	
8	29710-351	MOUNT, BELT GUARD	1	
9	0131 A	SCREW, HHC 1/4 - 20 x 1/2 IN.	3	
10	0181 B	WASHER, LOCK 1/4 IN.	5	
11	0949	NUT, HEX 1/4-20 IN.	3	
12	1023	SCREW, HHC 3/16-16 x 1-1/2 IN.	4	
13	10136	WASHER, FLAT 3/8 IN.	6	
14	27016-001	SPACER, MOTOR	2	
15	10133	NUT, NYLOC 3/8-16 IN.	6	
16	23811-354	BELT TIGHTENER	2	
18	0131 A	SCREW, HHC 1/4 - 20 x 1/2 IN.	2	
19	23865-001	SCREW, SELF-TAP	2	
20	24037-501	SWITCHBOX, 1 PHASE	1	
21	C799Mp55	SWITCHBOX, 3 PHASE	1	
22	27090-001	STARTER	1	
23	27090-003	TRIP, UNDER VOLTAGE	1	
24		BOLT	2	OBTAIN LOCALLY
25		WASHER, FLAT	2	OBTAIN LOCALLY
26		NUT, HEX	2	OBTAIN LOCALLY
27	CA302LN	SWITCH	1	

MP2 "MASON PRO" SAW — WATER PUMP ASSY. (ELECTRIC MOTORS ONLY)

WATER PUMP ASSY. (ELECTRIC MOTORS ONLY)

PLUG INTO
ELECTRIC MOTOR

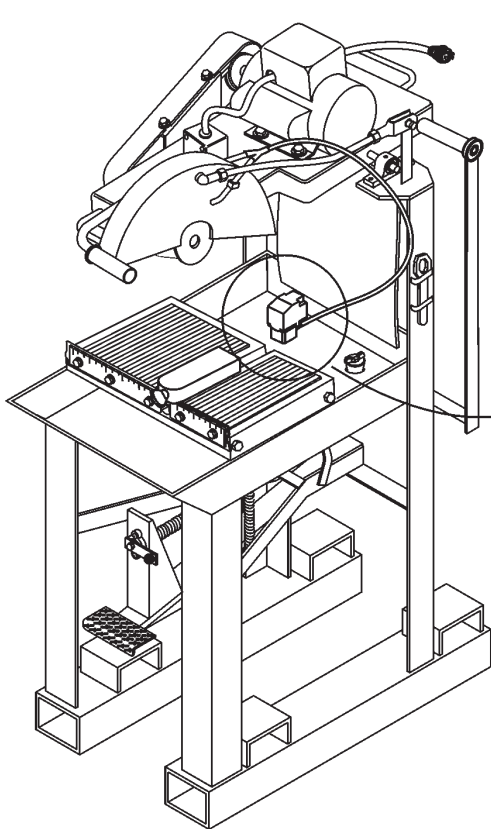
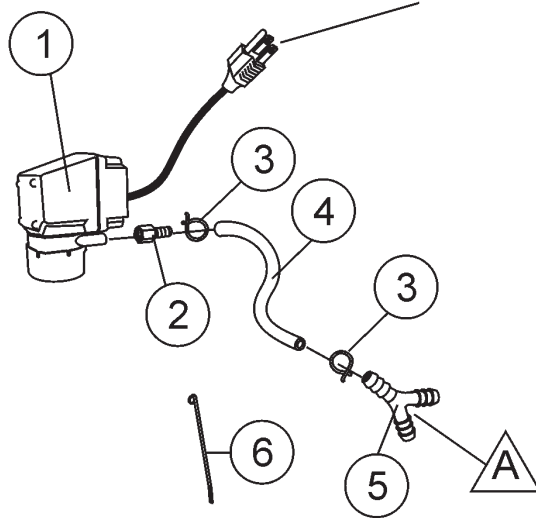

NOTES:



CONNECT TO MOTOR
PLATE & BLADE GUARD
ASSY., ITEMS 25 & 26

MP2 "MASON PRO" SAW — WATER PUMP ASSY. (ELECTRIC MOTORS ONLY)

WATER PUMP ASSY. (ELECTRIC MOTORS ONLY)

<u>NO.</u>	<u>PART NO.</u>	<u>PART NAME</u>	<u>QTY.</u>	<u>REMARKS</u>
1	23843-001	WATER PUMP, ELECTRIC	1	USE WITH SINGLE PHASE MOTORS
1	28693-501	WATER PUMP, ELECTRIC	1	USE WITH THREE PHASE MOTORS
2	26077-001	FITTING, BRASS 6 BARB 1/4FP	1	
3	12694-001	HOSE CLAMP	2	
4	23867-006	TUBING, VINYL 5/16	4	CUT TO 4 FT.
5	14233-002	Y-FITTING	1	
6	1662	TIE, CABLE	1	

MP2 "MASON PRO" SAW — GASOLINE ENGINE MOUNT ASSY.

GASOLINE ENGINE MOUNT ASSY.

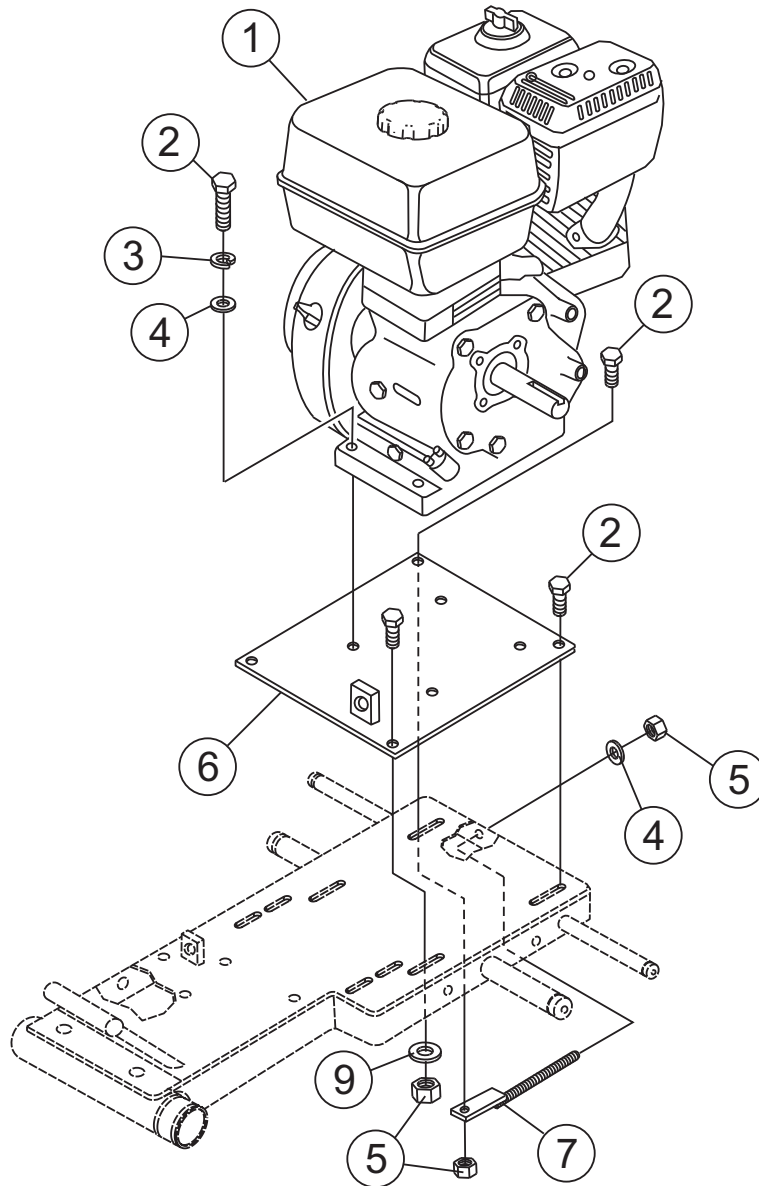

MP2 "MASON PRO" SAW — GASOLINE ENGINE MOUNT ASSY.

GASOLINE ENGINE MOUNT ASSY.

<u>NO.</u>	<u>PART NO.</u>	<u>PART NAME</u>	<u>QTY.</u>	<u>REMARKS</u>
1	15101	ENGINE, HONDA 9 H.P.	1	GX270QWH2
2	1023	SCREW, HHC 3/8-16 x 1-1/4 IN.	8	
3	0166 A	WASHER, LOCK 3/8 IN.	4	
4	10136	WASHER, FLAT 3/8 IN.	2	
5	10133	NUT, GRIPPO 3/8-16 IN.	4	
6	29004-351	BASE PLATE, ENGINE MOUNT	1	
7	23811-354	BELT TIGHTENER	2	
9	28275-001	WASHER, FLAT	2	

MP2 "MASON PRO" SAW — GASOLINE ENGINE JACKSHAFT ASSY.

GASOLINE ENGINE JACKSHAFT ASSY.

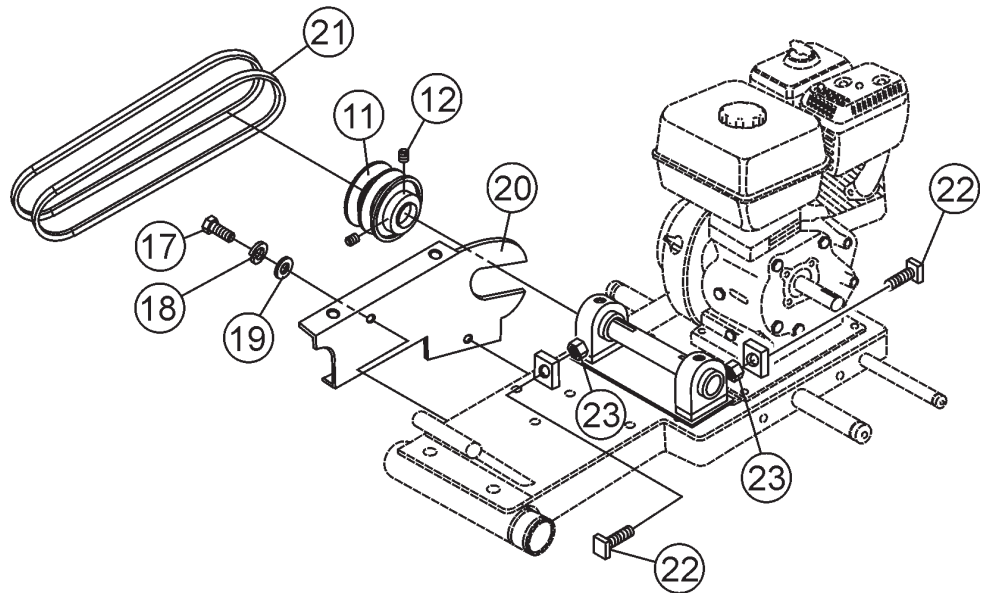
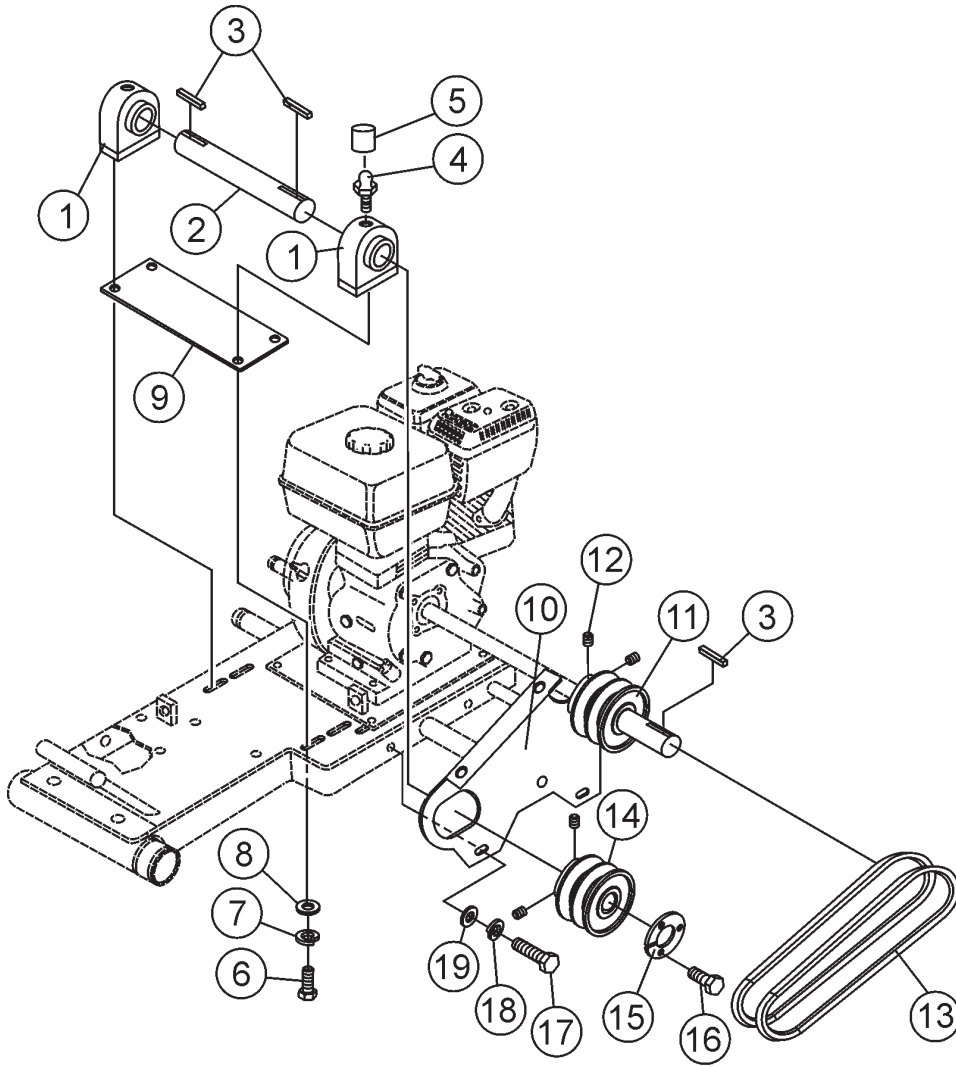

MP2 "MASON PRO" SAW — GASOLINE ENGINE JACKSHAFT ASSY.

GASOLINE ENGINE JACKSHAFT ASSY.

<u>NO.</u>	<u>PART NO.</u>	<u>PART NAME</u>	<u>QTY.</u>	<u>REMARKS</u>
1	28321-001	BEARINGS, PILLOW BLOCK	2	
2	28919-001	JACKSHAFT	1	
3	10057-011	KEY, SQUARE 1/4 X 1-1/4	3	
4	1162 A	CAP, GREASE ZERK #2 YLW	2	
5	2621	ZERK, GREASE STR 1/4-28	2	
6	1023	SCREW, HEX 3/8-16 x 1-1/4 IN.	4	
7	0166 A	WASHER, LOCK 3/8 IN.	4	
8	28275-001	WASHER, FLAT 3/8 IN.	4	
9	28844-001	SUPPORT PLATE, JACKSHAFT	1	
10	29005-351	BELT GUARD MOUNT	1	
11	28322-003	PULLEY, ENGINE/JACKSHAFT	2	
12	16193-006	SCREW, SET 5/16-18 x 3/8 IN.	4	
13	16779-012	DRIVE BELT 3VX250	2	
14	29007-001	PULLEY, JACKSHAFT	1	
15	29008-001	BUSHING, SPLIT TYPE	1	
16	0424	SCREW, 1/4-20 X 1-1/4 IN.	3	
17	0131 A	SCREW, HHC 1/4 - 20 X 3/4 IN.	4	
18	0181 B	WASHER, LOCK 1/4 IN.	4	
19	0949	WASHER, FLAT 1/4 IN.	4	
20	28769-351	MOUNTING BRACKET, BELT GUARD	1	
21	16779-004	SPINDLE V-BELT 3VX375	2	
22	27058-001	SCREW, SQ. HD 3/8-16 x 2.50 IN.	2	
23	1456	NUT, HEX 3/8-16 IN.	2	

MP2 "MASON PRO" SAW — GASOLINE ENGINE COVERS ASSY.

GASOLINE ENGINE COVERS ASSY.

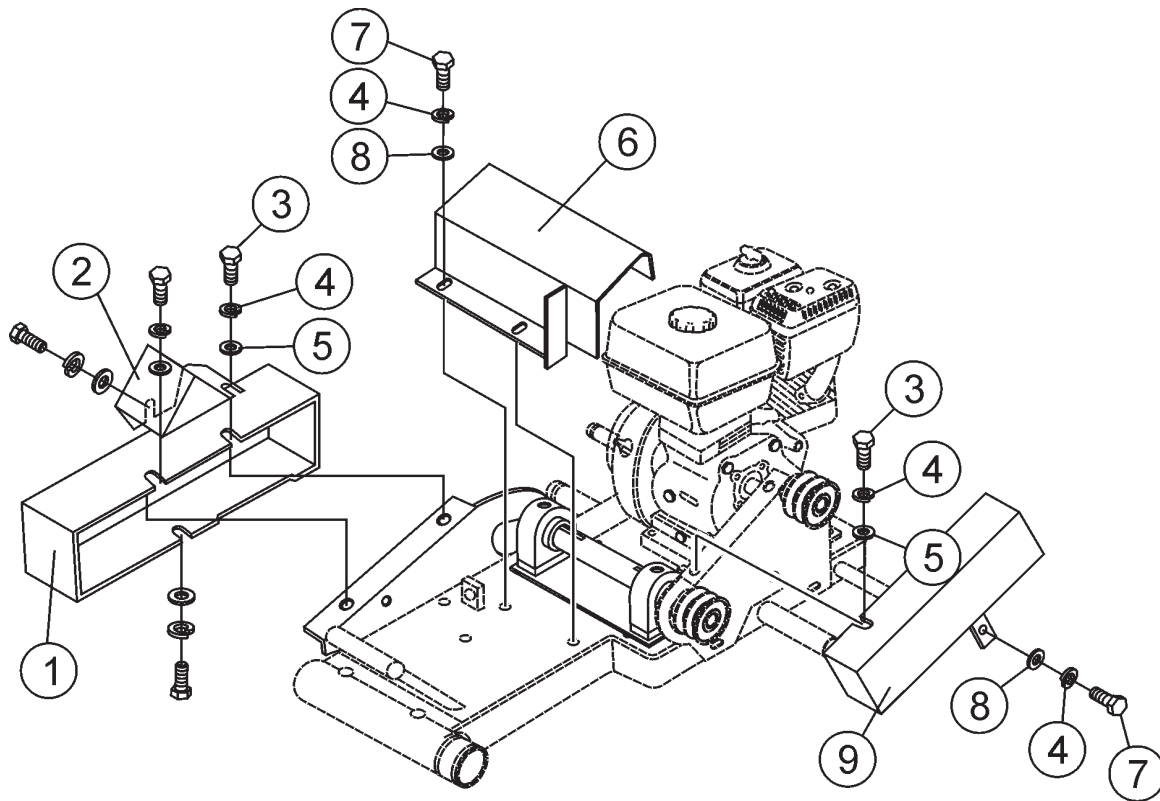

MP2 "MASON PRO" SAW — GASOLINE ENGINE COVERS ASSY.

GASOLINE ENGINE COVERS ASSY.

<u>NO.</u>	<u>PART NO.</u>	<u>PART NAME</u>	<u>QTY.</u>	<u>REMARKS</u>
1	28886-751	BELT GUARD, LEFT SIDE	1	RED
2	28178-751	COVER, WATER PUMP	1	RED
3	1579	SCREW, HEX 1/4-20 x 1/2	4	
4	0181 B	WASHER, LOCK 1/4 IN.	5	
5	0948	WASHER, FLAT 3/8 IN.	4	
6	28906-751	JACKSHAFT COVER	1	RED
7	0131 A	SCREW, HEX 1/4-20 x 3/4 IN.	2	
8	0181 B	WASHER, LOCK 1/4 IN.	2	
9	28928-751	BELT GUARD, JACKSHAFT	1	RED

MP2 "MASON PRO" SAW — WATER PUMP ASSY. (GASOLINE ENGINES ONLY)

WATER PUMP ASSY. (GASOLINE ENGINES ONLY)

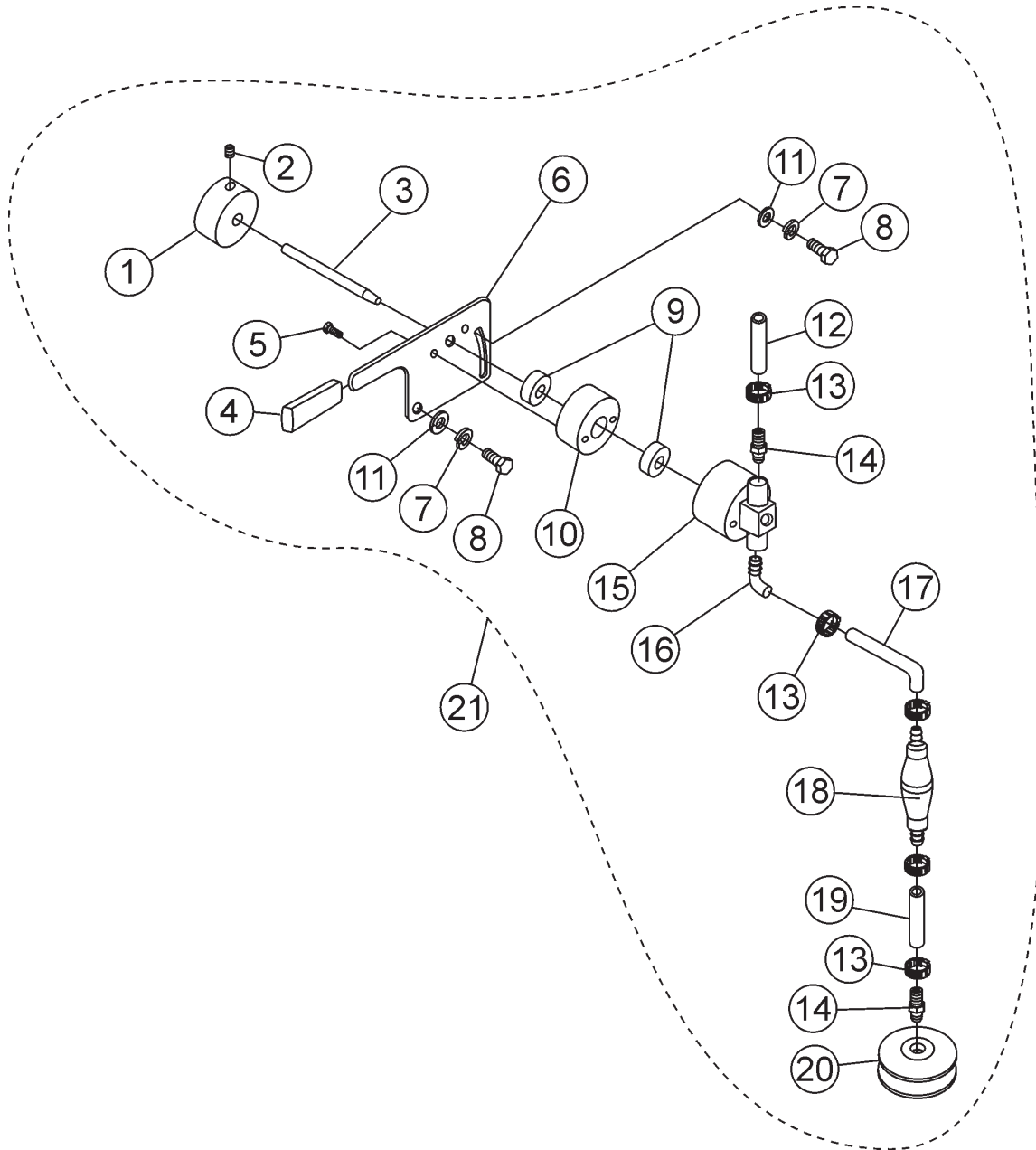

MP2 "MASON PRO" SAW — WATER PUMP ASSY. (GASOLINE ENGINES ONLY)

WATER PUMP ASSY. (GASOLINE ENGINES ONLY)

<u>NO.</u>	<u>PART NO.</u>	<u>PART NAME</u>	<u>QTY.</u>	<u>REMARKS</u>
1*	28917-002	PULLEY-WATER PUMP 2" IN.	1	
2*	10138	SCREW, SHS 1/4-20 X 1/2 IN.	4	
3*	28910-001	SHAFT, PUMP	1	
4*	3360	GRIP, PUMP HANDLE	1	
5*	10120-010	SCREW, RHM 1/4 - 20 X 5/8	2	
6*	28179-001	BRACKET, PUMP MOUNTING	1	
7*	0166 A	WASHER, LOCK, 3/8 IN.	2	
8*	0205	SCREW, HHC 3/8-16 X 1.0 IN.	2	
9*	09189-006	BEARING, BALL	2	
10*	28916-001	CAP, WATER PUMP	1	
11*	10136	WASHER, FLAT 3/8 IN.	2	
12*	60021	HOSE, BRAIDED PVC 3/8 x 5/8 IN.	2	CUT TO 24 IN.
13*	12694-001	HOSE CLAMP	4	
14*	25874-001	FITTING, PLASTIC STR 6 BARB	2	
15*	25802-001	HEAD, WATER PUMP	1	
16*	2925	FITTING, PLASTIC 90 6 BARB	1	
17*	60021	HOSE, BRAIDED PVC 3/8 x 5/8 IN.	3	CUT TO 32 IN.
18*	25875-001	BULB, PRIMER	1	
19*	60021	HOSE, BRAIDED PVC 3/8 x 5/8 IN.	1	CUT TO 8 IN.
20*	25685-001	STRAINER, INLET 3/8 IN.	1	
21	TRAK20WP	PUMP ASSY.	1	INCLUDES ITEMS W/*

MP2 "MASON PRO" SAW — STEP PEDAL ASSY.

STEP PEDAL ASSY.

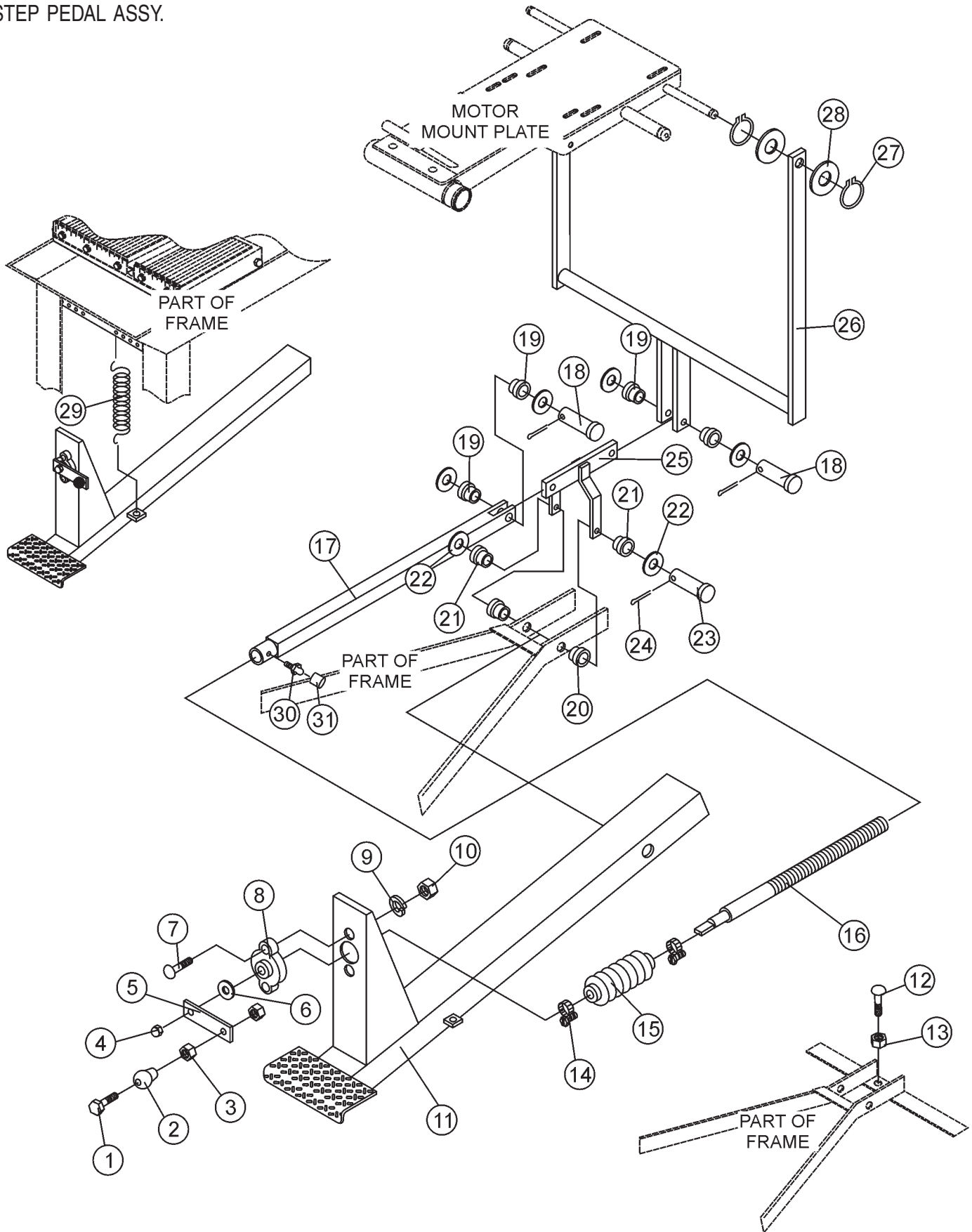

MP2 "MASON PRO" SAW — STEP PEDAL ASSY.

STEP PEDAL ASSY.

<u>NO.</u>	<u>PART NO.</u>	<u>PART NAME</u>	<u>QTY.</u>	<u>REMARKS</u>
1	06500-020	SCREW, HEX 5/16-18 x 2-1/2 IN.	1	
2	18637-001	KNOB	1	
3	0106	JAM NUT 5/16-18 IN.	2	
4	23860-001	ACORN NUT 1/2-13 IN.	1	
5	23768-001	HANDLE, BLADE HEIGHT ADJ.	1	
6	23730-001	WASHER, FLAT	1	
7	0424	SCREW, HEX 1/4-20 x 1-1/4 IN.	2	
8	23842-001	BEARING-FLANGED	1	
9	0181 B	WASHER, LOCK 1/4 IN.	2	
10	0949	NUT, HEX 1/4-20 IN.	2	
11	26976-351	FOOT PEDAL	1	
12	27017-001	BOLT, CARRIAGE 1/2-13 x 4 IN.	1	
13	968011	NUT, HEX 1/2-13	1	
14	14821-005	CLAMP	2	
15	23845-002	BELLOWS	1	
16	27076-001	ROD, BLADE HEIGHT ADJ.	1	
17	27018-351	PIVOT TUBE	1	
18	19974	CLEVIS PIN 1/2 DIA. x 1-1/2 IN.	2	
19	27025-001	BUSHING	4	
20	27024-002	BUSHING, FLANGED	2	
21	27024-001	BUSHING, FLANGED	2	
22	0447	WASHER, FLAT 1/2 IN.	6	
23	27079-002	CLEVIS PIN 1/2 DIA. x 5 IN.	1	
24	3216	COTTER PIN 1/8 DIA. x 7/8 IN.	3	
25	27012-351	PIVOT BRACKET, STEP PEDAL	1	
26	28957-351	PIVOT BRACKET, MOTOR PLATE	1	
27	10096-019	SNAP RING	4	
28	3264	WASHER, FLAT 1 IN.	4	
29	27028-001	EXTENSION SPRING	2	
30	2621	ZERK FITTING	1	
31	1162 A	CAP, GREASE ZERK #2 YLW	1	

GX270QWH2 ENGINE — AIR CLEANER ASSY.

AIR CLEANER ASSY.

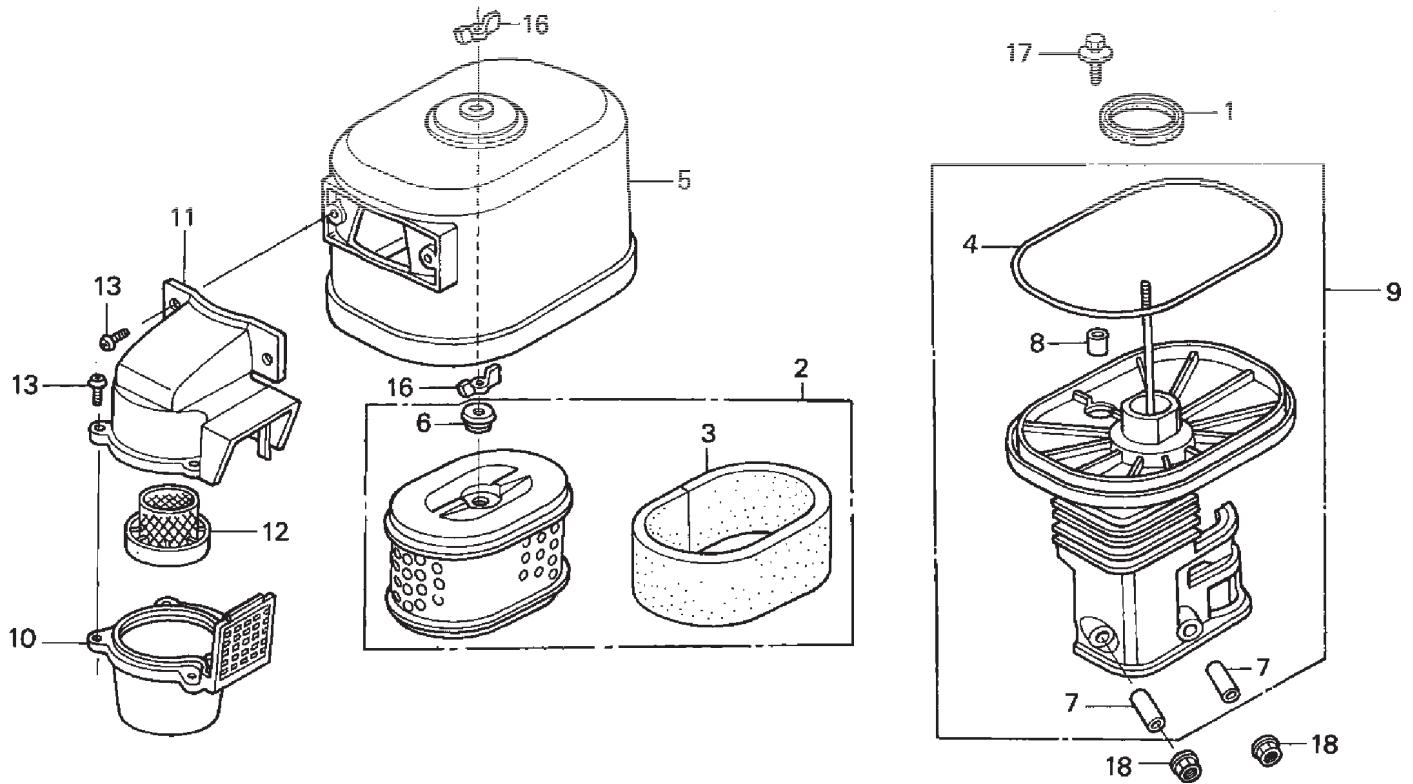

GX270QWH2 ENGINE — AIR CLEANER ASSY.

AIR CLEANER ASSY.

<u>NO.</u>	<u>PART NO.</u>	<u>PART NAME</u>	<u>QTY.</u>	<u>REMARKS</u>
1	16271ZE2000	GASKET, ELBOW	1	
2	17210ZE3010	ELEMENT, AIR CLEANER	1	INCLUDES ITEMS W/\$
2	17210ZE3505	ELEMENT, AIR CLEANER	1	INCLUDES ITEMS W/\$
3\$	17218ZE3000	FILTER (OUTER)	1	
3\$	17218ZE3505	FILTER (OUTER)	1	
4*	17219HA2405	SEAL, AIR CLEANER COVER	1	
4*	17219KL4000	SEAL, AIR CLEANER COVER	1	
5	17230ZE3841	COVER, AIR CLEANER (CYCLONE)	1	
6\$	17232891000	GROMMET, AIR CLEANER	1	
7*	17238ZE2310	COLLAR, AIR CLEANER	2	
8*	17239ZE3840	COLLAR B, AIR CLEANER	1	
9	17410ZE3840	ELBOW, AIR CLEANER	1	INCLUDES ITEMS W/*
10	17470ZE3841	CASE, PRE AIR CLEANER	1	
11	17475ZE3841	CAP, PRE AIR CLEANER	1	
12	17476ZE3841	GUIDE, PRE AIR CLEANER	1	
13	90142MB0000	SCREW, PAN (5X16.5)	5	
16	90325044000	WINGNUT, TOOL BOX SETTING	2	
17	90009ZE2003	BOLT-WASHER (6X22)	1	
18	9405006000	NUT, FLANGE (6MM)	2	

GX270QWH2 ENGINE — CAMSHAFT ASSY.

CAMSHAFT ASSY.

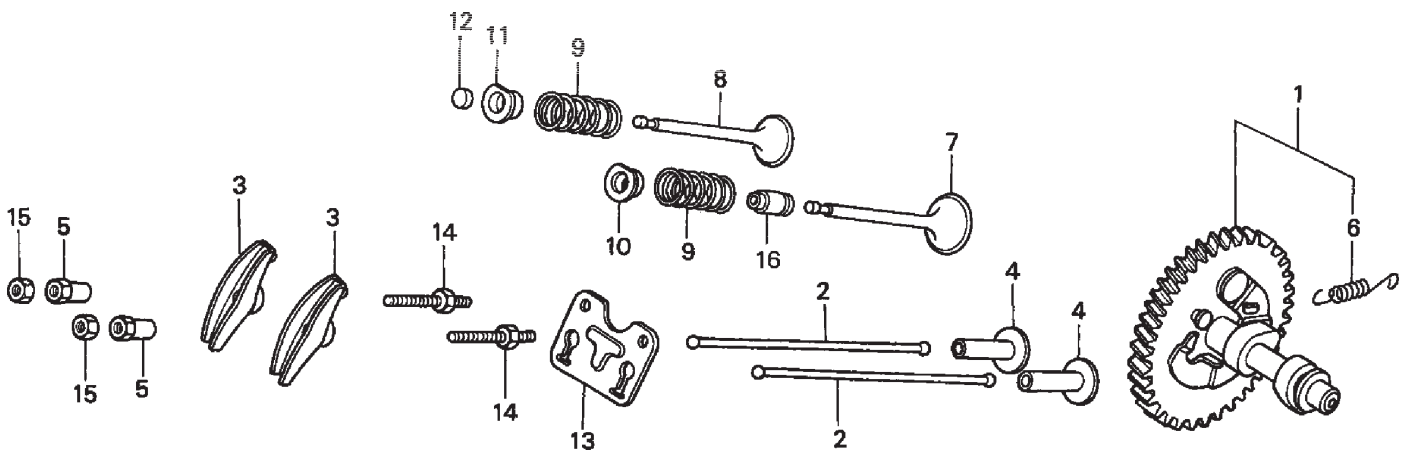

GX270QWH2 ENGINE — CAMSHAFT ASSY.

CAMSHAFT ASSY.

<u>NO.</u>	<u>PART NO.</u>	<u>PART NAME</u>	<u>QTY.</u>	<u>REMARKS</u>
1	14100ZE3020	CAMSHAFT ASSY.	1	INCLUDES ITEMS W/*
2	14410ZE2013	ROD, PUSH	2	
3	14431ZE2010	ARM, VALVE ROCKER	2	
4	14441ZE2000	LIFTER, VALVE	2	
5	14451ZE1013	PIVOT, ROCKER ARM	2	
6*	14568ZE1000	SPRING, WEIGHT RETURN	1	
7	14711ZE2000	VALVE, IN.	1	
8	14721ZE2000	VALVE, EX.	1	
9	14751ZE2003	SPRING, VALVE	2	
10	14771ZE2000	RETAINER, IN. VALVE SPRING	1	
11	14773ZE2000	RETAINER, EX. VALVE SPRING	1	
12	14781ZE2000	ROTATOR, VALVE	1	
13	14791ZE2010	PLATE, PUSH ROD GUIDE	1	
14	90012ZE0010	BOLT, PIVOT (8MM)	2	
15	90206ZE1000	NUT, PIVOT ADJ.	2	
16	12209ZE8003	SEAL, VALVE STEM	1	

GX270QWH2 ENGINE — CARBURETOR ASSY.

CARBURETOR ASSY.

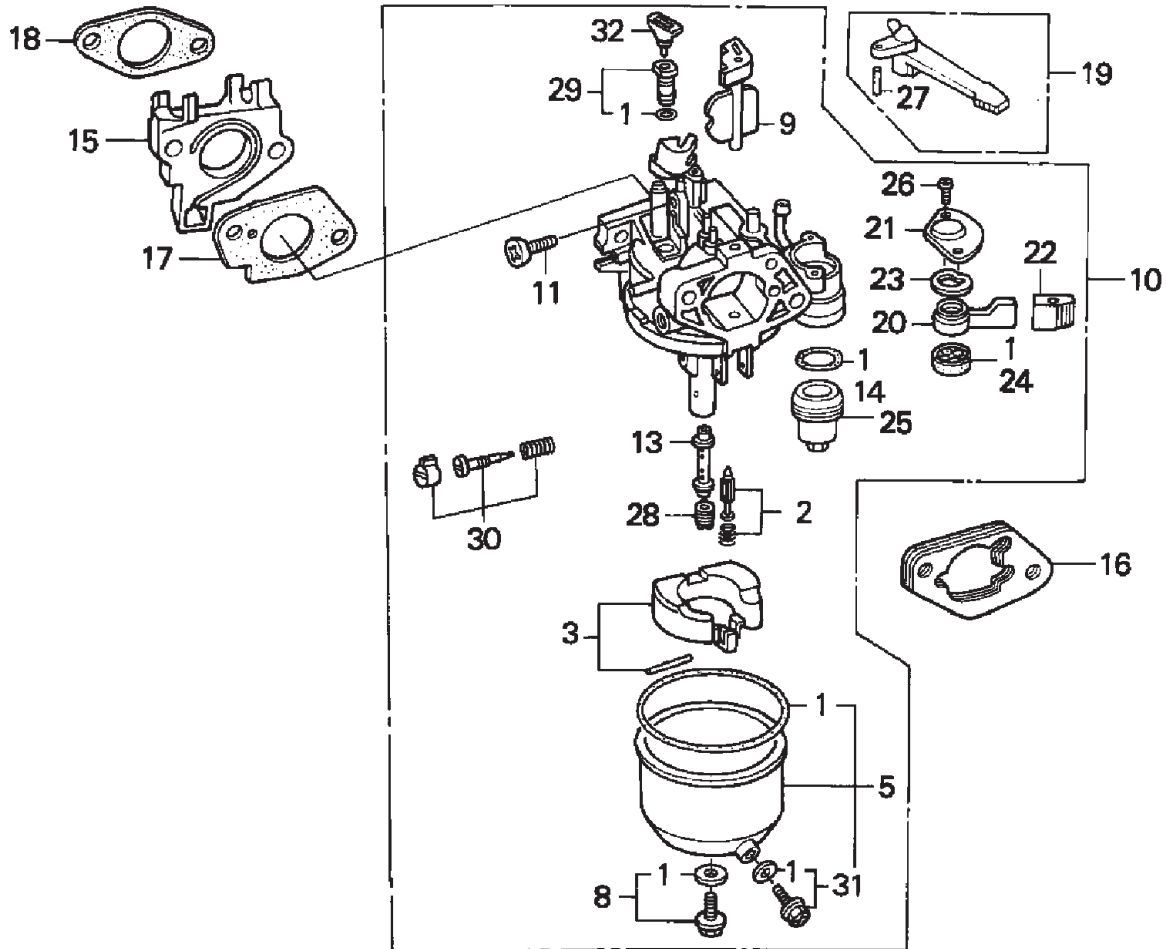

GX270QWH2 ENGINE — CARBURETOR ASSY.

CARBURETOR ASSY.

<u>NO.</u>	<u>PART NO.</u>	<u>PART NAME</u>	<u>QTY.</u>	<u>REMARKS</u>
1\$*	16010ZE2812	GASKET SET	1	
2*	16011ZA0931	VALVE SET, FLOAT	1	
3*	16013ZA0931	FLOAT SET	1	
*5	16015ZE8005	CHAMBER SET, FLOAT	1	INCLUDES ITEMS W/\$
8*	16028ZE0005	SCREW SET B	1	
9*	16044ZE2005	CHOKE SET	1	
10	16100ZH9W01	CARBURETOR ASSY. (BE75A B)	1	INCLUDES ITEMS W/*
11*	16124ZE0005	SCREW, THROTTLE STOP	1	
13*	16166ZH9W00	NOZZLE, MAIN	1	
14*	16173001004	GASKET, FUEL STRAINER CUP	1	
15	16211ZE2000	INSULATOR, CARBURETOR	1	
16	16220ZA0702	SPACER, CARBURETOR	1	
17	16221ZA0800	GASKET, CARBURETOR	1	
18	16223ZA0800	GASKET, INSULATOR	1	
19	16610ZE1000	LEVER, CHOKE (STD)	1	INCLUDES ITEMS W/+
20*	16953ZE1812	LEVER, VALVE	1	
21*	16954ZE1812	PLATE, LEVER SETTING	1	
23*	16956ZE1811	SPRING, VALVE LEVER	1	
24*	16957ZE1812	GASKET, VALVE	1	
25*	16967ZE0811	CUP, FUEL STRAINER	1	
26*	93500030060H	SCREW, PAN (3X6)	2	
27+	9430520122	PIN, SPRING (2X12)	1	
28	99101ZH80880	JET, MAIN (#88) (OPTIONAL)	1	
28	99101ZH80900	JET, MAIN (#90) (OPTIONAL)	1	
28*	99101ZH80920	JET, MAIN (#92)	1	
29*	99204ZE00350	JET SET, PILOT (#35)	1	
30*	16016ZH7W01	SCREW SET	1	
31\$*	16024ZE1811	SCREW SET, DRAIN	1	
32*	16172ZE3W10	COLLAR, SET	1	

GX270QWH2 ENGINE — CONTROL ASSY.

CONTROL ASSY.

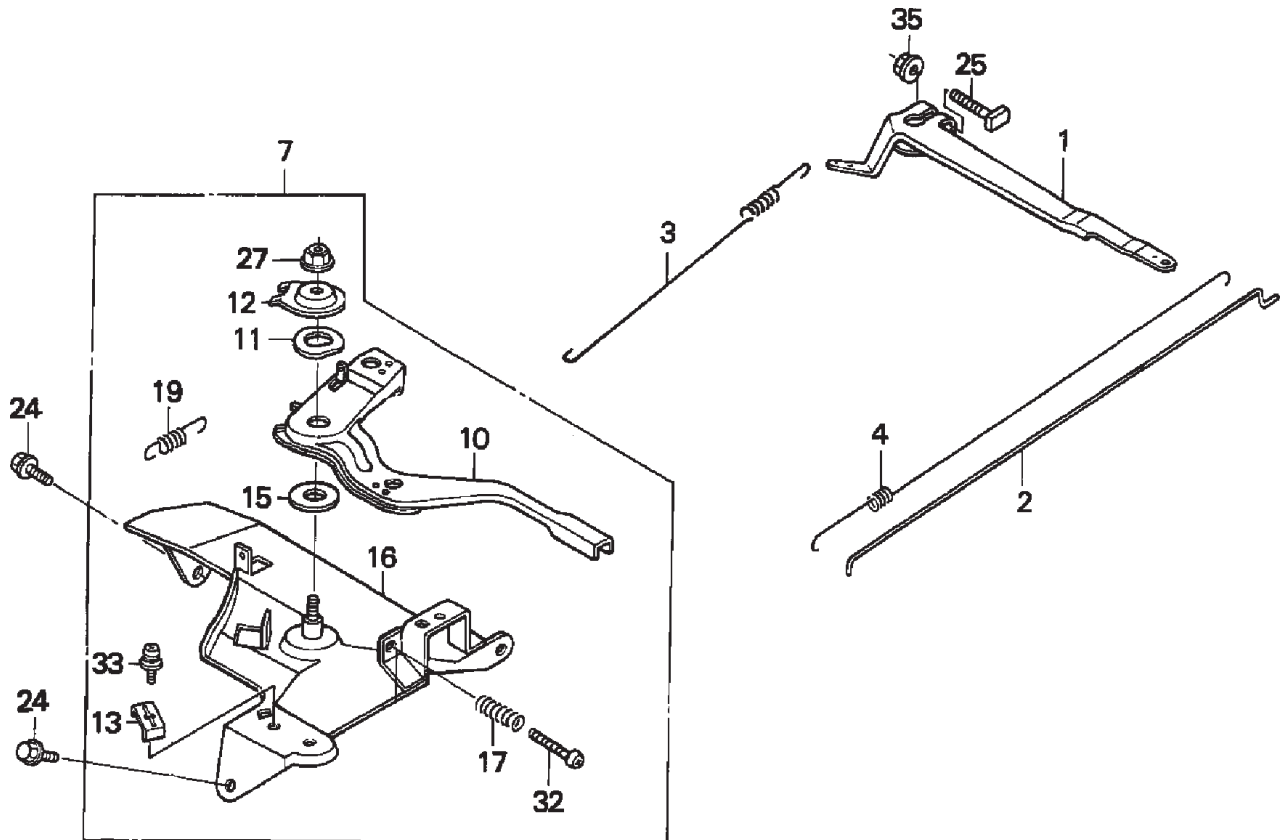

GX270QWH2 ENGINE — CONTROL ASSY.

CONTROL ASSY.

<u>NO.</u>	<u>PART NO.</u>	<u>PART NAME</u>	<u>QTY.</u>	<u>REMARKS</u>
1	16551ZE2000	ARM, GOVERNOR	1	
2	16555ZE2000	ROD, GOVERNOR	1	
3	16561ZE2000	SPRING, GOVERNOR	1	
4	16562ZE2000	SPRING, THROTTLE RETURN	1	
7	16570ZE2W20	CONTROL ASSY. (REMOTE)	1	INCLUDES ITEMS W/*
10*	16571ZE2W00	LEVER, CONTROL	1	
11*	16574ZE1000	SPRING, LEVER	1	
12*	16575ZE2W00	WASHER, CONTROL LEVER	1	
13*	16576891000	HOLDER, CABLE	1	
15*	16578ZE1000	SPACER, CONTROL LEVER	1	
16*	16581ZE2W00	BASE, CONTROL	1	
17*	16584883300	SPRING, CONTROL ADJUSTING	1	
19*	16592883310	SPRING, CABLE RETURN	1	
24	90013883000	BOLT, FLANGE (6X12) (CT200)	2	
25	90015ZE5010	BOLT, GOVERNOR ARM	1	
27*	90114SA0000	NUT, SELF-LOCK (6MM)	1	
32*	93500050280A	SCREW, PAN (5X28)	1	
33*	93500050160A	SCREW, PAN (5X16)	1	
35	9405006000	NUT, FLANGE (6MM)	1	

GX270QWH2 ENGINE — CRANKCASE COVER ASSY.

CRANKCASE COVER ASSY.

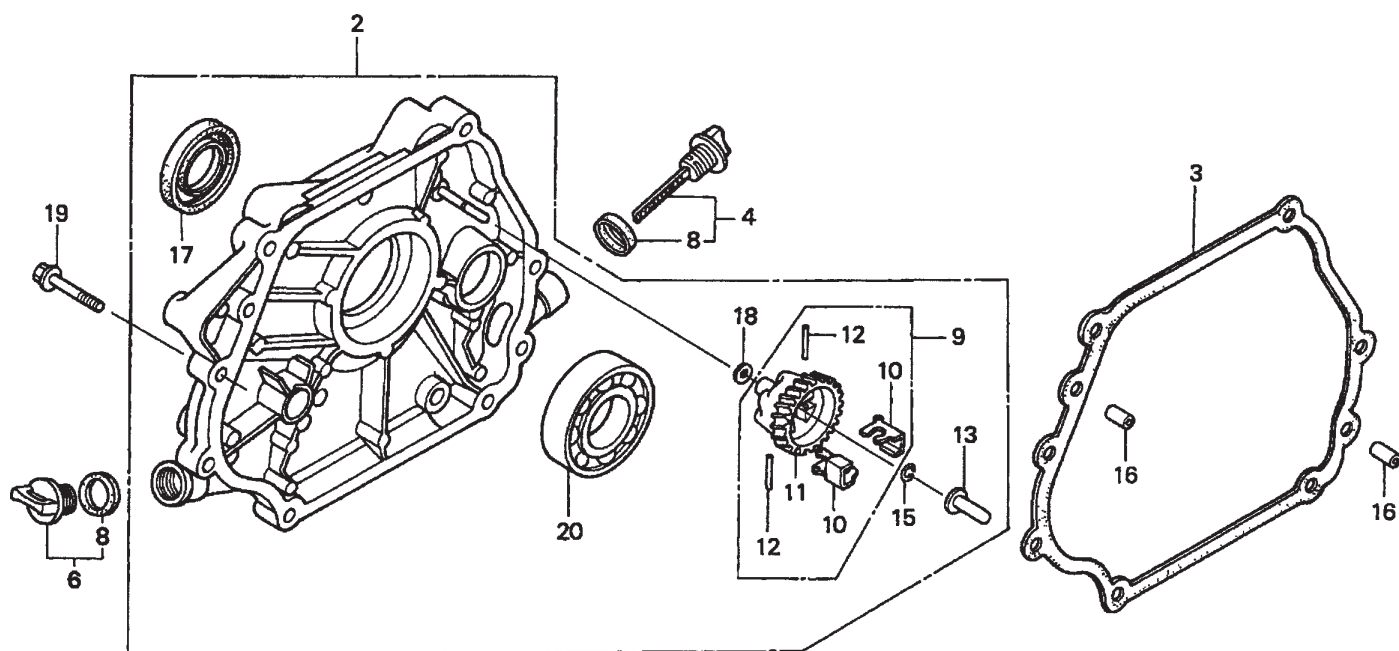

GX270QWH2 ENGINE — CRANKCASE COVER ASSY.

CRANKCASE COVER ASSY.

<u>NO.</u>	<u>PART NO.</u>	<u>PART NAME</u>	<u>QTY.</u>	<u>REMARKS</u>
2	11300ZE2602	COVER ASSY., CRANKCASE (Q-TYPE)	1	INCLUDES ITEMS W/*
3	11381ZE2801	GASKET, CASE COVER	1	INCLUDES ITEMS W/+
4	15600735003	CAP ASSY., OIL FILLER	1	INCLUDES ITEMS W/+
6	15600ZG4003	CAP ASSY., OIL FILLER	1	
8+	15625ZE1003	GASKET, OIL FILLER CAP	2	INCLUDES ITEMS W/\$
9*	16510ZE2000	GOVERNOR ASSY. (STD)	1	
10\$*	16511ZE2000	WEIGHT, GOVERNOR	2	
11\$*	16512ZE2000	HOLDER, GOVERNOR WEIGHT	1	
12\$*	16513ZE2000	PIN, GOVERNOR WEIGHT	2	
13*	16531Z0A000	SLIDER, GOVERNOR	1	
15*	90602ZE1000	CLIP, GOVERNOR HOLDER	1	
16	90701HC4000	PIN, DOWEL (8X12)	2	
17*	91201890003	OIL SEAL (30X46X8)	1	
18*	9410106800	WASHER, PLAIN (6MM)	1	
19	957010803500	BOLT, FLANGE (8X35)	7	
20*	961006206000	BEARING, RADIAL BALL (6206)	1	

GX270QWH2 ENGINE — CRANKSHAFT ASSY.

CRANKSHAFT ASSY.

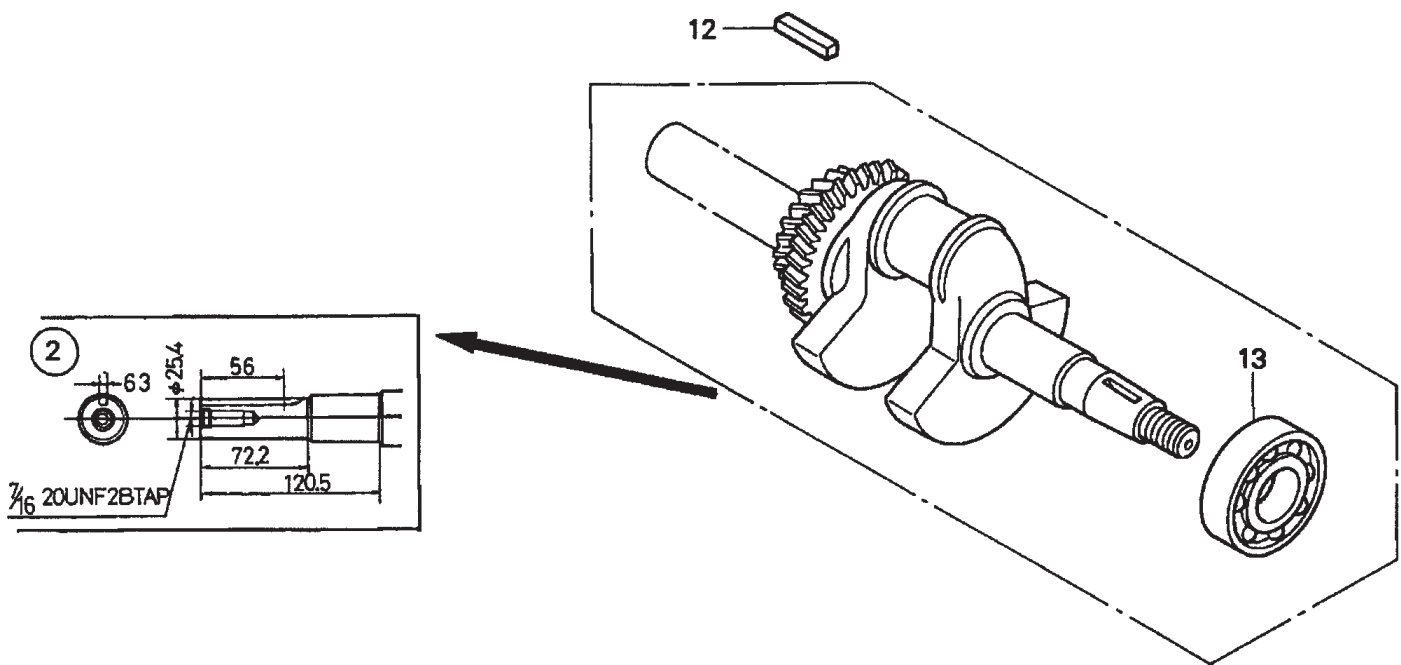

GX270QWH2 ENGINE — CRANKSHAFT ASSY.

CRANKSHAFT ASSY.

<u>NO.</u>	<u>PART NO.</u>	<u>PART NAME</u>	<u>QTY.</u>	<u>REMARKS</u>
2	13310ZH9600	CRANKSHAFT (Q-TYPE)	1	INCLUDES ITEMS W/*
12	90745ZE2600	KEY (6.3X6.3X43)	1	
13*	91001ZH9003	BEARING, RADIAL BALL (6206 SH)	1	

GX270QWH2 ENGINE — CYLINDER BARREL ASSY.

CYLINDER BARREL ASSY.

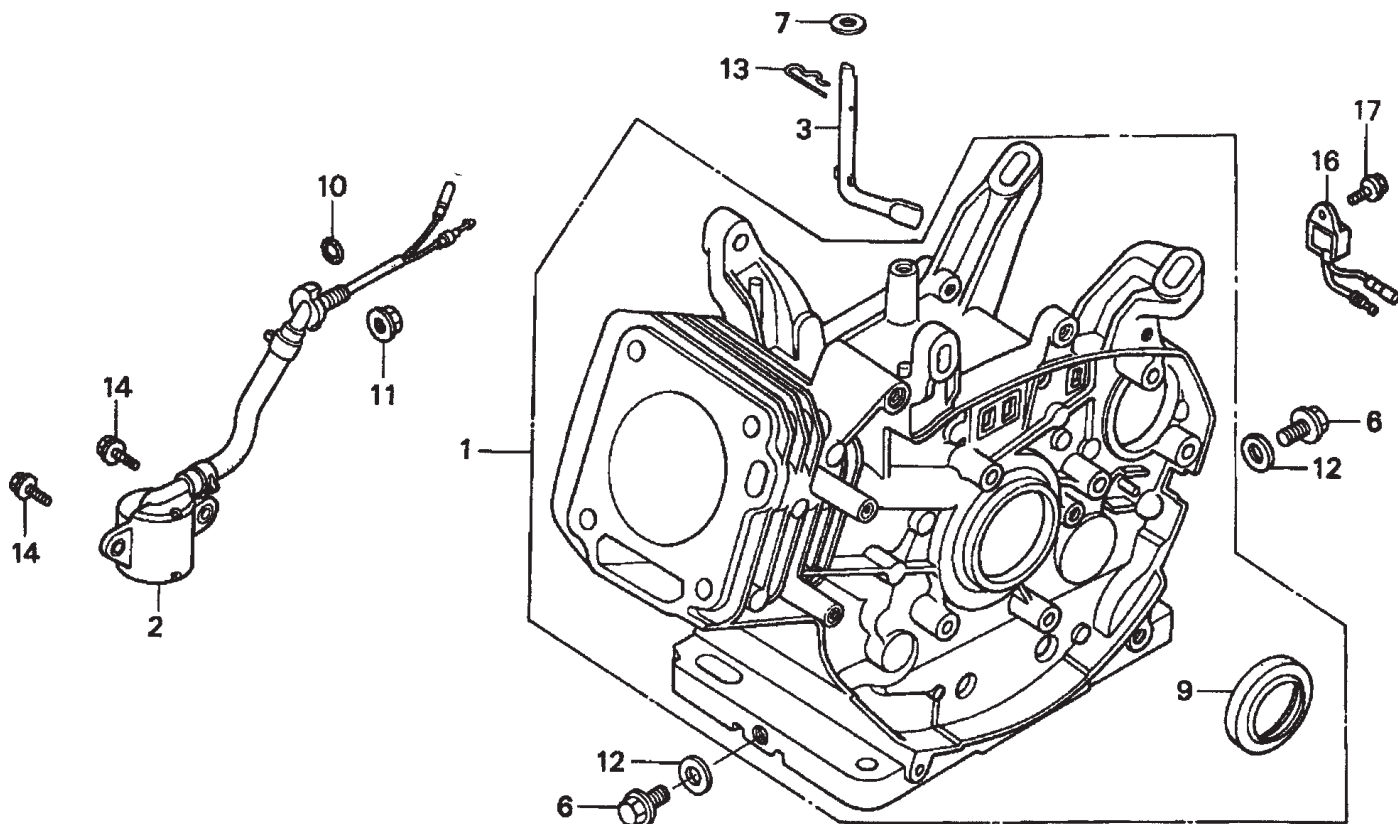

GX270QWH2 ENGINE — CYLINDER BARREL ASSY.

CYLINDER BARREL ASSY.

<u>NO.</u>	<u>PART NO.</u>	<u>PART NAME</u>	<u>QTY.</u>	<u>REMARKS</u>
1	12000ZH9802	CYLINDER ASSY. (ALERT).....	1	INCLUDES ITEMS W/*
2	15510ZE2043	SWITCH ASSY., OIL LEVER	1	
3	16541ZE2010	SHAFT, GOVERNOR ARM	1	
6	90131896650	BOLT, DRAIN PLUG	2	
7	90446KE1000	WASHER (8.2X17X0.8)	1	
9*	91201890003	OIL SEAL (30X46X8)	1	
10	91353671003	O-RING (13.5X1.5) (ARAI)	1	
11	9405010000	NUT, FLANGE (10MM)	1	
12	9410912000	WASHER, DRAIN PLUG (12MM)	2	
13	9425110000	PIN, LOCK (10MM)	1	
14	957010601200	BOLT, FLANGE (6X12)	2	
16	34150ZH7003	ALERT UNIT, OIL	1	
17	90013883000	BOLT, FLANGE (6X12) (CT200)	1	

GX270QWH2 ENGINE — CYLINDER HEAD ASSY.

CYLINDER HEAD ASSY.

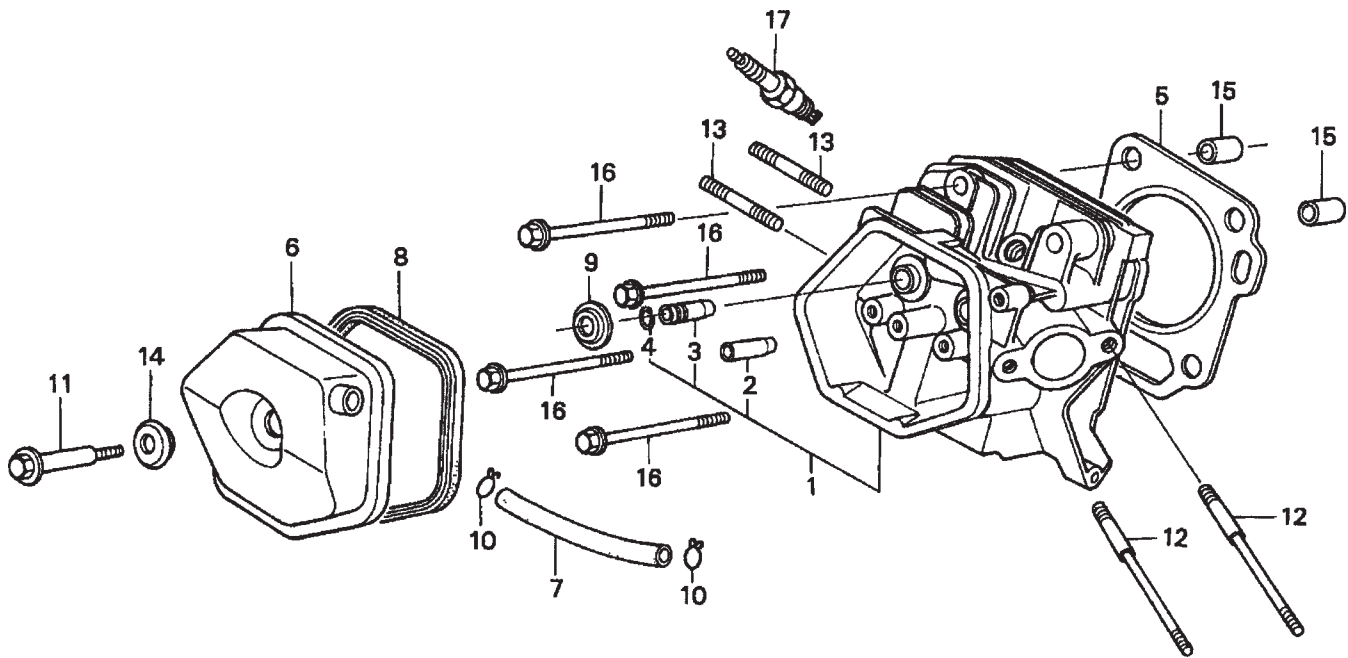

GX270QWH2 ENGINE — CYLINDER HEAD ASSY.

CYLINDER HEAD ASSY.

<u>NO.</u>	<u>PART NO.</u>	<u>PART NAME</u>	<u>QTY.</u>	<u>REMARKS</u>
1	12200ZH9000	CYLINDER HEAD	1	INCLUDES ITEMS W/*
2*	12204ZE2306	GUIDE, VALVE (OS) (OPTIONAL)	1	
3*	12205ZE2305	GUIDE, EX. VALVE (OS) (OPTIONAL)	1	
4*	12216ZE2300	CLIP, VALVE GUIDE	1	
5	12251ZH9000	GASKET, CYLINDER HEAD	1	
6	12310ZE3791	COVER, HEAD	1	
7	12315ZE3840	TUBE, BREATHER	1	
8	12391ZE2020	GASKET, CYLINDER HEAD COVER	1	
9	14775ZE2010	SEAT, VALVE SPRING	1	
10	17316611000	CLIP, BREATHER TUBE	2	
11	90014ZE2000	BOLT, HEAD COVER	1	
12	90042ZE2000	BOLT, STUD (8X123)	2	
13	92900080320E	BOLT 2, STUD (8X32)	2	
14	90441ZE2010	WASHER, HEAD COVER	1	
15	9430112200	PIN A, DOWEL (12X20)	2	
16	957011008000	BOLT, FLANGE (10X80)	4	
17	9807955846	SPARK PLUG (BPR5ES) (NGK) (OPTIONAL)	1	
17	9807955855	SPARK PLUG (W16EPR-U) (DENSO) (OPTIONAL)	1	
17	9807956846	SPARK PLUG (BPR6ES) (NGK)	1	
17	9807956855	SPARK PLUG (W20EPR-U) (DENSO)	1	

GX270QWH2 ENGINE — FAN COVER ASSY.

FAN COVER ASSY.

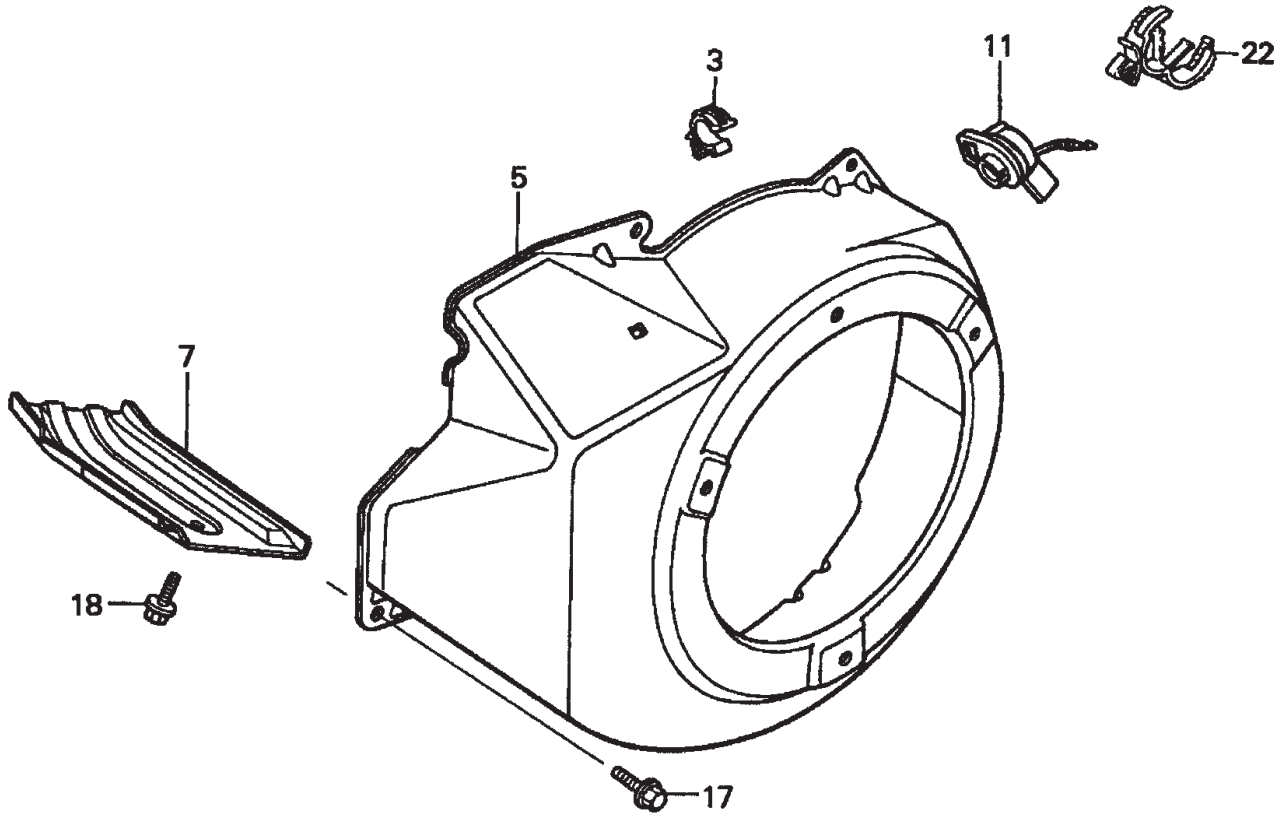

GX270QWH2 ENGINE — FAN COVER ASSY.

FAN COVER ASSY.

<u>NO.</u>	<u>PART NO.</u>	<u>PART NAME</u>	<u>QTY.</u>	<u>REMARKS</u>
3	16731ZE2003	CLIP, TUBE	1	
5	19610ZE2010ZC	COVER, FAN *NH1* (BLACK)	1	
7	19631ZE2D00	SHROUD	1	
11	36100ZH7003	SWITCH ASSY., ENGINE STOP	1	
17	90013883000	BOLT, FLANGE (6X12) (CT200)	5	
18	90013883000	BOLT, FLANGE (6X12) (CT200)	1	
22	90684ZA0601	CLIP, WIRE	1	

GX270QWH2 ENGINE — FLYWHEEL ASSY.

FLYWHEEL ASSY.

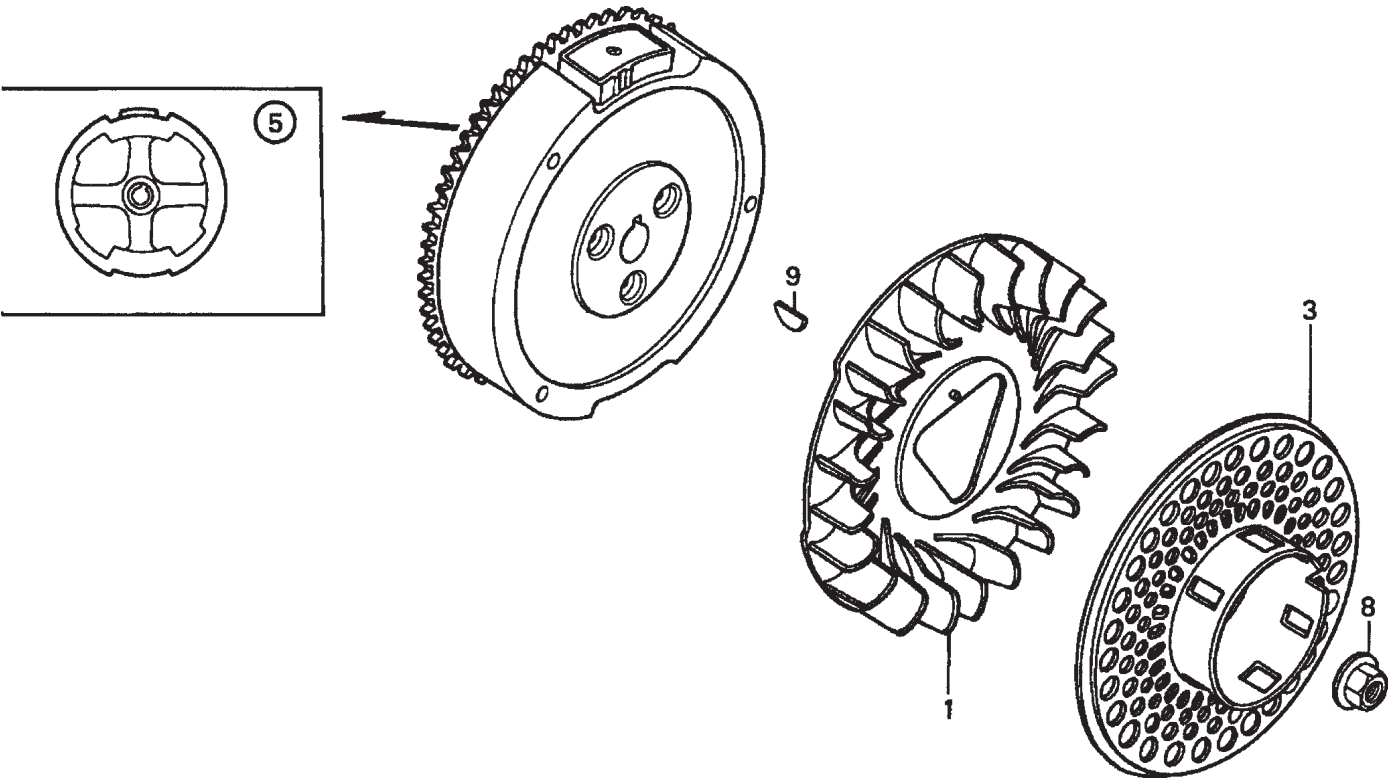

GX270QWH2 ENGINE — FLYWHEEL ASSY.

FLYWHEEL ASSY.

<u>NO.</u>	<u>PART NO.</u>	<u>PART NAME</u>	<u>QTY.</u>	<u>REMARKS</u>
1	19511ZE2000	FAN, COOLING	1	
3	28450ZE2W11	PULLEY, STARTER (SCREEN GRID)	1	
5	31100ZE2010	FLYWHEEL	1	
8	90201ZE3V00	NUT, SPECIAL (16MM) (1)	1	
9	90741ZE2000	KEY, SPECIAL WOODRUFF (25X18)	1	

GX270QWH2 ENGINE — FUEL TANK ASSY.

FUEL TANK ASSY.

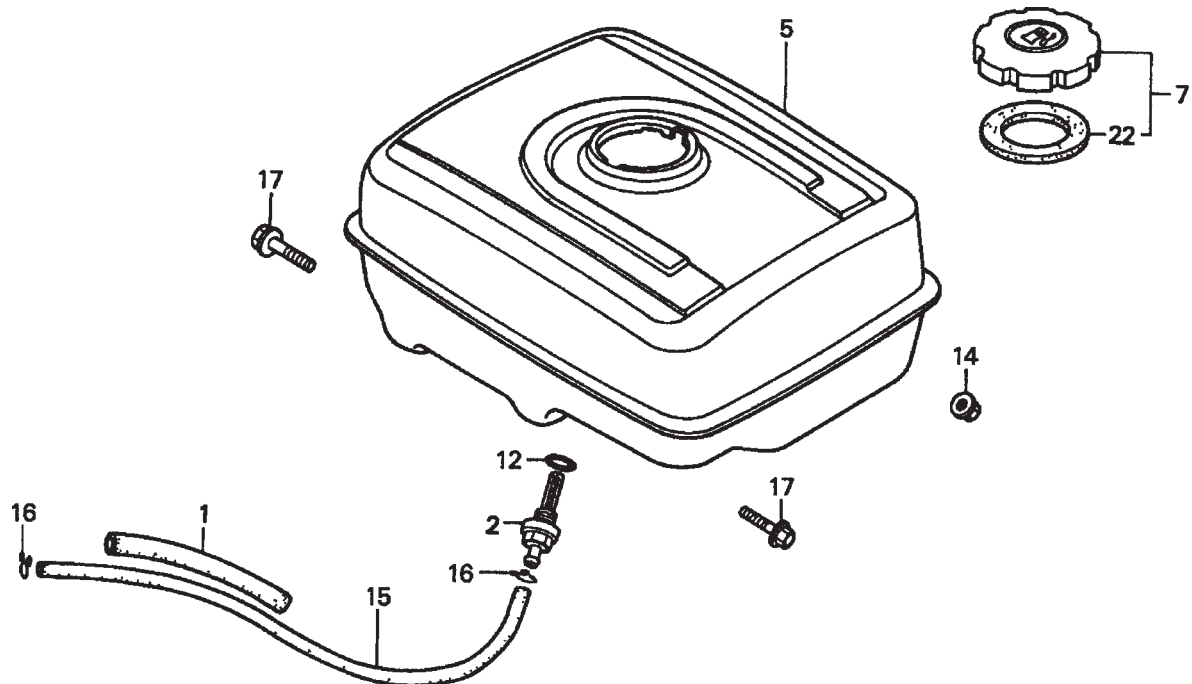

GX270QWH2 ENGINE — FUEL TANK ASSY.

FUEL TANK ASSY.

<u>NO.</u>	<u>PART NO.</u>	<u>PART NAME</u>	<u>QTY.</u>	<u>REMARKS</u>
1	16854ZH8000	RUBBER, SUPPORTER (107MM)	1	
2	16955ZE1000	JOINT, FUEL TANK	1	
5	17510ZE2010ZD	TANK, FUEL *NH1* (BLACK)	1	
7	17620ZH7023	CAP, FUEL FILLER	1.....	INCLUDES ITEMS W/*
12	91353671003	O-RING (13.5X1.5) (ARAI)	1	
14	9405008000	NUT, FLANGE (8MM)	2	
15	950014500360M	BULK HOSE, FUEL (4.5X3000) (4.5X222)	1	
16	9500202080	CLIP, TUBE (B8)	2	
17	957010802500	BOLT, FLANGE (8X25)	2	
22	17631ZH7003	GASKET, FUEL FILLER CAP	1	

GX270QWH2 ENGINE — IGNITION COIL ASSY.

IGNITION COIL ASSY.

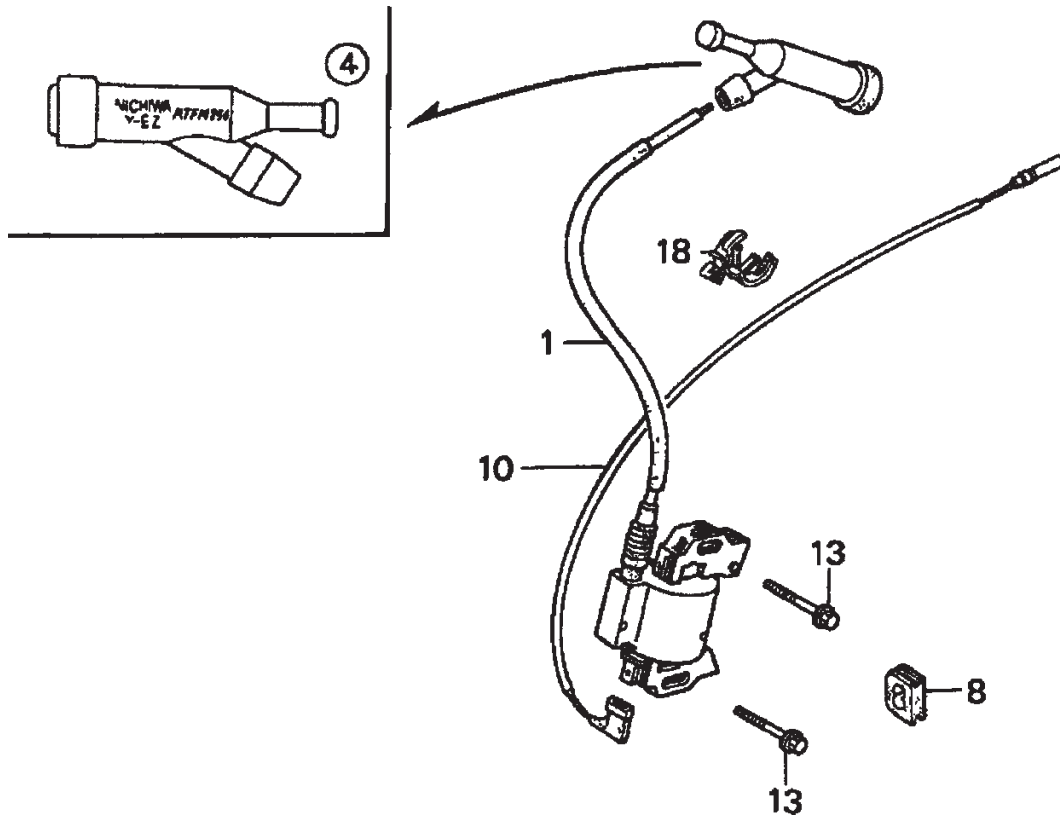

GX270QWH2 ENGINE — IGNITION COIL ASSY.

IGNITION COIL ASSY.

<u>NO.</u>	<u>PART NO.</u>	<u>PART NAME</u>	<u>QTY.</u>	<u>REMARKS</u>
1	30500ZF6W02	COIL ASSY., IGNITION	1	
4	30700ZE1013	CAP ASSY., NOISE SUPPRESSOR	1	
8	31512ZE2000	GROMMET, WIRE	1	
10	36101ZE1010	WIRE, STOP SWITCH (370MM)	1	
13	90015883000	BOLT, FLANGE (6X28)	2	
18	90684ZA0601	CLIP, WIRE HARNESS	1	

GX270QWH2 ENGINE — LABELS ASSY.

LABELS ASSY.

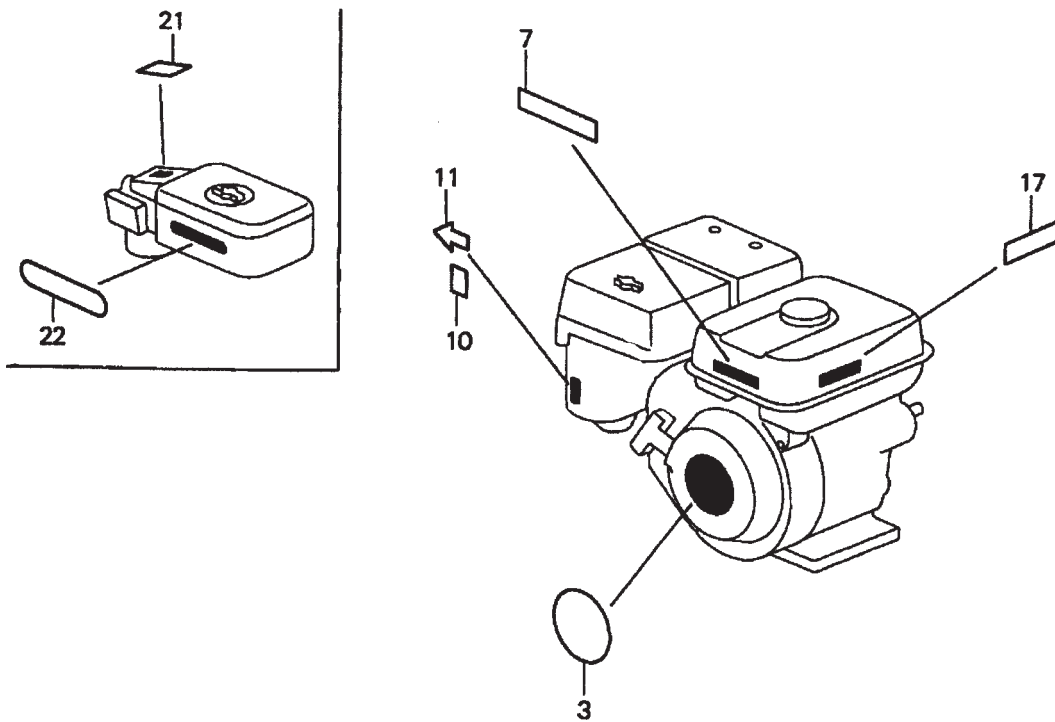

GX270QWH2 ENGINE — LABELS ASSY.

LABELS ASSY.

<u>NO.</u>	<u>PART NO.</u>	<u>PART NAME</u>	<u>QTY.</u>	<u>REMARKS</u>
3	87521ZH9020	EMBLEM (INTERNAL)	1	
7	87522ZH9010	LABEL, CAUTION	1	
10	87528ZE2810	MARK, CHOKE (EXTERNAL)	1	
17	87532ZH8810	MARK, OIL ALERT (E)	1	
21	87534ZE1841	LABEL, AIR CLEANER CAUTION	1	
22	87535ZE1840	MARK, AIR CLEANER SALES POINT	1	

GX270QWH2 ENGINE — MUFFLER ASSY.

MUFFLER (2) ASSY.

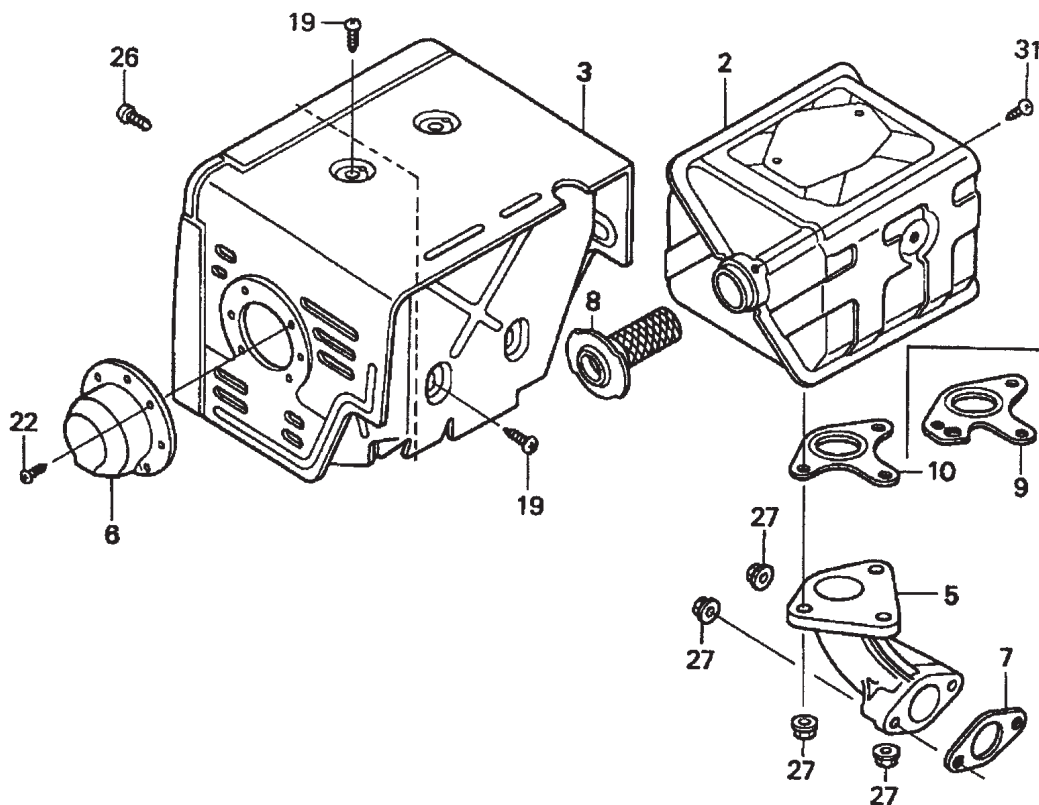

GX270QWH2 ENGINE — MUFFLER ASSY.

MUFFLER ASSY.

<u>NO.</u>	<u>PART NO.</u>	<u>PART NAME</u>	<u>QTY.</u>	<u>REMARKS</u>
2	18310ZE2W61	MUFFLER (100DB)	1	
3	18320ZE2W61	PROTECTOR, MUFFLER	1	
5	18330ZH9N00	PIPE, EX.	1	
6	18331ZE2810	CAP, MUFFLER	1	
7	18333ZF6W01	GASKET, EX. PIPE	1	
8	18355ZE2W00	ARRESTER, SPARK (OPTIONAL)	1	
9	18381ZE2W10	GASKET, MUFFLER (ARRESTER) (OPTIONAL)	1	
10	18381ZE2800	GASKET, MUFFLER	1	
19	90050ZE1000	SCREW, TAPPING (5X8)	4	
22	90055ZE1000	SCREW, TAPPING (4X6)	3	
26	90006ZE2000	SCREW, TAPPING (6X10)	1	
27	9405008000	NUT, FLANGE (8MM)	5	
31	90055ZE1000	SCREW, TAPPING (4X6) (OPTIONAL)	1	

GX270QWH2 ENGINE — PISTON ASSY.

PISTON ASSY.

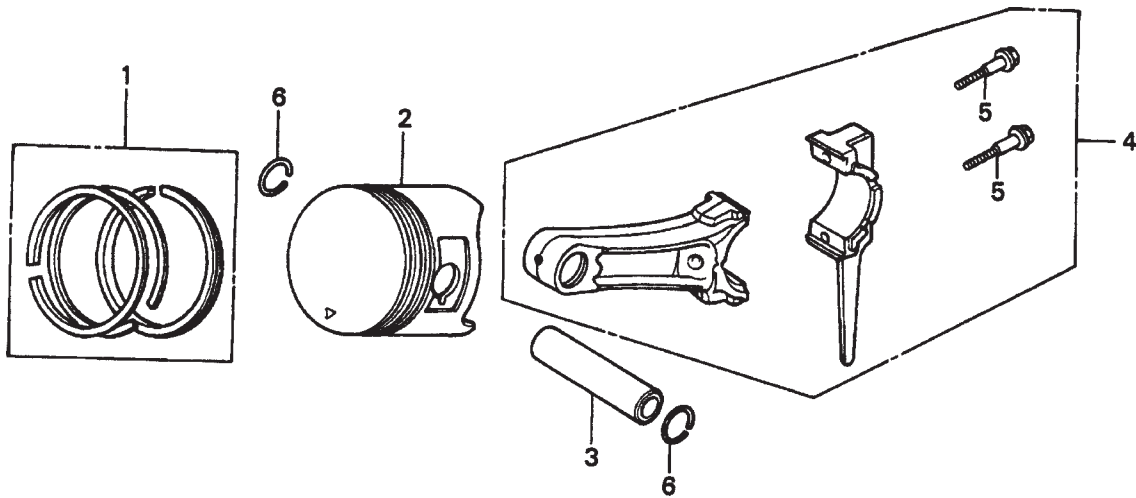

GX270QWH2 ENGINE — PISTON ASSY.

PISTON ASSY.

<u>NO.</u>	<u>PART NO.</u>	<u>PART NAME</u>	<u>QTY.</u>	<u>REMARKS</u>
1	13010ZE8601	RING SET, PISTON (STD)	1	
1	13011ZE8601	RING SET, PISTON (OS 0.25) (OPTIONAL)	1	
1	13012ZE8601	RING SET, PISTON (OS 0.50) (OPTIONAL)	1	
1	13013ZE8601	RING SET, PISTON (0.75) (OPTIONAL)	1	
2	13101ZH9000	PISTON (STD)	1	
2	13102ZH9000	PISTON (OS 0.25) (OPTIONAL)	1	
2	13103ZH9000	PISTON (OS 0.50) (OPTIONAL)	1	
2	13104ZH9000	PISTON (0.75) (OPTIONAL)	1	
3	13111ZE2000	PIN, PISTON	1	
4	13200ZE2010	ROD ASSY., CONNECTING (STD)	1	INCLUDES ITEMS W/*
4	13200ZE2305	ROD ASSY., CONNECTING (US 0.25) (OPTIONAL)	1	INCLUDES ITEMS W/*
5*	90001ZE8000	BOLT, CONNECTING ROD	2	
6	90551ZE1000	CLIP, PISTON PIN (18MM)	2	

GX270QWH2 ENGINE — RECOIL STARTER ASSY.

RECOIL STARTER ASSY.

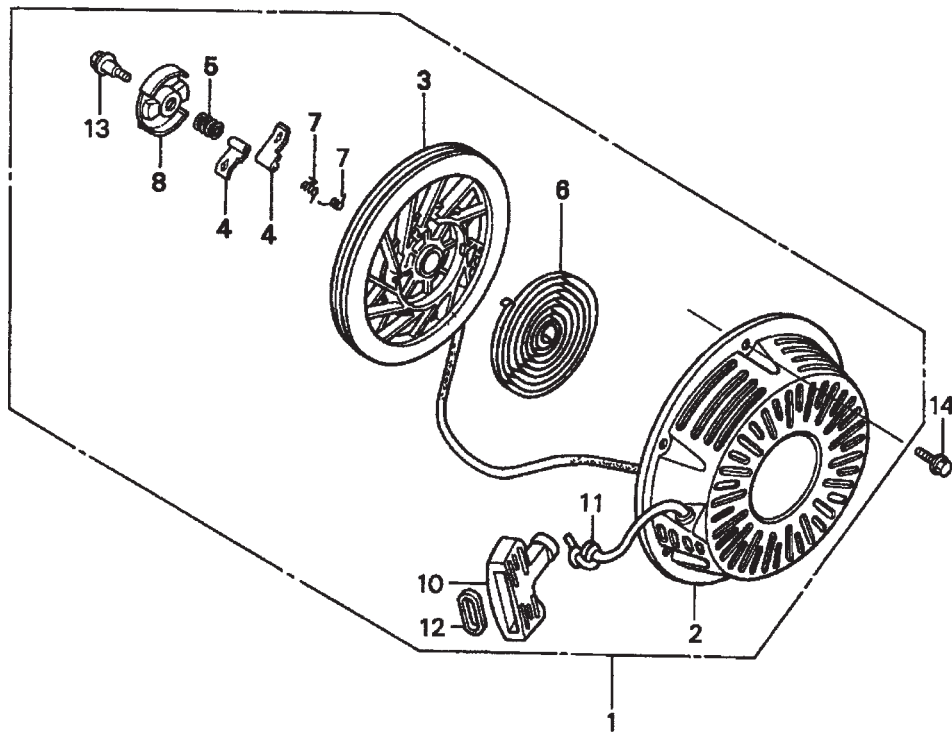

GX270QWH2 ENGINE — RECOIL STARTER ASSY.

RECOIL STARTER ASSY.

<u>NO.</u>	<u>PART NO.</u>	<u>PART NAME</u>	<u>QTY.</u>	<u>REMARKS</u>
1	28400ZE2W01ZB	STARTER ASSY., RECOIL *NH1* (BLACK).....	1	INCLUDES ITEMS W/*
2*	28410ZE2W01ZB	CASE, RECOIL STARTER *NH1* (BLACK)	1	
3*	28421ZE2W01	PULLEY, RECOIL STARTER	1	
4*	28422ZE2W01	RATCHET, STARTER	2	
5*	28441ZE2W01	SPRING, FRICTION	1	
6*	28442ZE2W01	SPRING, STARTER RETURN	1	
7*	28443ZE2W01	SPRING, RATCHET	2	
8*	28444ZE2W01	RETAINER, SPRING	1	
10*	28461ZE2W02	GRIP, STARTER	1	
11*	28462ZE2W11	ROPE, RECOIL STARTER	1	
13*	90004ZE2W01	SCREW, CENTER	1	
14	90008ZE2003	BOLT, FLANGE (6X10)	3	

TERMS AND CONDITIONS OF SALE — PARTS

PAYMENT TERMS

Terms of payment for parts are net 30 days.

FREIGHT POLICY

All parts orders will be shipped collect or prepaid with the charges added to the invoice. All shipments are F.O.B. point of origin. Multiquip's responsibility ceases when a signed manifest has been obtained from the carrier, and any claim for shortage or damage must be settled between the consignee and the carrier.

MINIMUM ORDER

The minimum charge for orders from Multiquip is \$15.00 net. Customers will be asked for instructions regarding handling of orders not meeting this requirement.

RETURNED GOODS POLICY

Return shipments will be accepted and credit will be allowed, subject to the following provisions:

1. A Returned Material Authorization must be approved by Multiquip prior to shipment.
2. To obtain a Return Material Authorization, a list must be provided to Multiquip Parts Sales that defines item numbers, quantities, and descriptions of the items to be returned.
 - a. The parts numbers and descriptions must match the current parts price list.
 - b. The list must be typed or computer generated.
 - c. The list must state the reason(s) for the return.
 - d. The list must reference the sales order(s) or invoice(s) under which the items were originally purchased.
 - e. The list must include the name and phone number of the person requesting the RMA.
3. A copy of the Return Material Authorization must accompany the return shipment.
4. Freight is at the sender's expense. All parts must be returned freight prepaid to Multiquip's designated receiving point.

5. Parts must be in new and resalable condition, in the original Multiquip package (if any), and with Multiquip part numbers clearly marked.
6. The following items are not returnable:
 - a. Obsolete parts. (If an item is in the price book and shows as being replaced by another item, it is obsolete.)
 - b. Any parts with a limited shelf life (such as gaskets, seals, "O" rings, and other rubber parts) that were purchased more than six months prior to the return date.
 - c. Any line item with an extended dealer net price of less than \$5.00.
 - d. Special order items.
 - e. Electrical components.
 - f. Paint, chemicals, and lubricants.
 - g. Decals and paper products.
 - h. Items purchased in kits.
7. The sender will be notified of any material received that is not acceptable.
8. Such material will be held for five working days from notification, pending instructions. If a reply is not received within five days, the material will be returned to the sender at his expense.
9. Credit on returned parts will be issued at dealer net price at time of the original purchase, less a 15% restocking charge.
10. In cases where an item is accepted, for which the original purchase document can not be determined, the price will be based on the list price that was effective twelve months prior to the RMA date.
11. Credit issued will be applied to future purchases only.

PRICING AND REBATES

Prices are subject to change without prior notice. Price changes are effective on a specific date and all orders received on or after that date will be billed at the revised price. Rebates for price declines and added charges for price increases will not be made for stock on hand at the time of any price change.

Multiquip reserves the right to quote and sell direct to Government agencies, and to Original Equipment Manufacturer accounts who use our products as integral parts of their own products.

SPECIAL EXPEDITING SERVICE

A \$35.00 surcharge will be added to the invoice for special handling including bus shipments, insured parcel post or in cases where Multiquip must personally deliver the parts to the carrier.

LIMITATIONS OF SELLER'S LIABILITY

Multiquip shall not be liable hereunder for damages in excess of the purchase price of the item with respect to which damages are claimed, and in no event shall Multiquip be liable for loss of profit or good will or for any other special, consequential or incidental damages.

LIMITATION OF WARRANTIES

No warranties, express or implied, are made in connection with the sale of parts or trade accessories nor as to any engine not manufactured by Multiquip. Such warranties made in connection with the sale of new, complete units are made exclusively by a statement of warranty packaged with such units, and Multiquip neither assumes nor authorizes any person to assume for it any other obligation or liability whatever in connection with the sale of its products. Apart from such written statement of warranty, there are no warranties, express, implied or statutory, which extend beyond the description of the products on the face hereof.

Effective: February 22, 2006

PARTS MANUAL

HERE'S HOW TO GET HELP

PLEASE HAVE THE MODEL AND SERIAL
NUMBER ON-HAND WHEN CALLING

UNITED STATES

Multiquip Corporate Office

18910 Wilmington Ave. Tel. (800) 421-1244
Carson, CA 90746 Fax (800) 537-3927
Contact: mq@multiquip.com

Mayco Parts

800-306-2926 Fax: 800-672-7877
310-537-3700 Fax: 310-637-3284

Service Department

800-421-1244 Fax: 310-537-4259
310-537-3700

MQ Parts Department

800-427-1244 Fax: 800-672-7877
310-537-3700 Fax: 310-637-3284

Warranty Department

800-421-1244, Ext. 279 Fax: 310-537-1173
310-537-3700, Ext. 279

Technical Assistance

800-478-1244 Fax: 310-631-5032

MEXICO

MQ Cipsa

Carr. Fed. Mexico-Puebla KM 126.5 Tel: (52) 222-225-9900
Momoxpan, Cholula, Puebla 72760 Mexico Fax: (52) 222-285-0420
Contact: pmastretta@cipsa.com.mx

UNITED KINGDOM

Multiquip (UK) Limited Head Office

Unit 2, Northpoint Industrial Estate, Tel: 0161 339 2223
Global Lane, Fax: 0161 339 3226
Dukinfield, Cheshire SK16 4UJ
Contact: sales@multiquip.co.uk

CANADA

Multiquip

4110 Industriel Boul. Tel: (450) 625-2244
Laval, Quebec, Canada H7L 6V3 Tel: (877) 963-4411
Contact: jmartin@multiquip.com Fax: (450) 625-8664

© COPYRIGHT 2010, MULTQUIP INC.

Multiquip Inc and the MQ logo are registered trademarks of Multiquip Inc. and may not be used, reproduced, or altered without written permission. All other trademarks are the property of their respective owners and used with permission.

This manual MUST accompany the equipment at all times. This manual is considered a permanent part of the equipment and should remain with the unit if resold.

The information and specifications included in this publication were in effect at the time of approval for printing. Illustrations, descriptions, references and technical data contained in this manual are for guidance only and may not be considered as binding. Multiquip Inc. reserves the right to discontinue or change specifications, design or the information published in this publication at any time without notice and without incurring any obligations.

Your Local Dealer is:

