

PARTS MANUAL



StreetPro SERIES MODEL SP1E16A PROFESSIONAL PAVEMENT SAW (5HP ELECTRIC MOTOR)

Revision #0 (05/10/10)

To find the latest revision of this
publication, visit our website at:
www.multiquip.com



THIS MANUAL MUST ACCOMPANY THE EQUIPMENT AT ALL TIMES.

PN: 38271

TABLE OF CONTENTS

SP1E16A Pavement Saw

Table Of Contents	2
Parts Ordering Procedures.....	3
Explanation Of Code In Remarks Column	4
Suggested Spare Parts	5
Nameplate And Decals Assembly.....	6-7
Frame/Undercarriage Assembly.....	8-9
Electric Motor Assembly.....	10-11
Blade And Water Assembly.....	12-13
Pointer Assembly.....	14-15
Terms And Conditions Of Sale — Parts	16

NOTICE

Part numbers are subject to change without notice.

PARTS ORDERING PROCEDURES

Ordering parts has never been easier! Choose from three easy options:

Effective:
January 1st, 2006

www.multiquip.com



Order via Internet (Dealers Only):

Order parts on-line using Multiquip's SmartEquip website!

- View Parts Diagrams
- Order Parts
- Print Specification Information



If you have an MQ Account, to obtain a Username and Password, E-mail us at: parts@multiquip.com.

To obtain an MQ Account, contact your District Sales Manager for more information.

Goto www.multiquip.com and click on **Order Parts** to log in and save!

Use the **internet** and qualify for a **5% Discount** on *Standard orders* for all orders which include complete part numbers.*

Note: Discounts Are Subject To Change

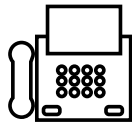

Order via Fax (Dealers Only):

All customers are welcome to order parts via Fax.

Domestic (US) Customers dial:
1-800-6-PARTS-7 (800-672-7877)

Fax your order in and qualify for a **2% Discount** on *Standard orders* for all orders which include complete part numbers.*

Note: Discounts Are Subject To Change



Order via Phone: Domestic (US) Dealers Call:
1-800-427-1244

Non-Dealer Customers:

Contact your local Multiquip Dealer for parts or call 800-427-1244 for help in locating a dealer near you.



International Customers should contact their local Multiquip Representatives for Parts Ordering information.

When ordering parts, please supply:

- | | |
|---|--|
| <input type="checkbox"/> Dealer Account Number | <input type="checkbox"/> Specify Preferred Method of Shipment: |
| <input type="checkbox"/> Dealer Name and Address | <input checked="" type="checkbox"/> UPS/Fed Ex <input checked="" type="checkbox"/> DHL |
| <input type="checkbox"/> Shipping Address (if different than billing address) | <input type="checkbox"/> Priority One <input checked="" type="checkbox"/> Truck |
| <input type="checkbox"/> Return Fax Number | <input type="checkbox"/> Ground |
| <input type="checkbox"/> Applicable Model Number | <input type="checkbox"/> Next Day |
| <input type="checkbox"/> Quantity, Part Number and Description of Each Part | <input type="checkbox"/> Second/Third Day |

NOTICE

All orders are treated as *Standard Orders* and will ship the same day if received prior to 3PM PST.

WE ACCEPT ALL MAJOR CREDIT CARDS!



EXPLANATION OF CODE IN REMARKS COLUMN

The following section explains the different symbols and remarks used in the Parts section of this manual. Use the help numbers found on the back page of the manual if there are any questions.

NOTICE

The contents and part numbers listed in the parts section are subject to change **without notice**. Multiquip does not guarantee the availability of the parts listed.

SAMPLE PARTS LIST

NO.	PART NO.	PART NAME	QTY.	REMARKS
1	12345	BOLT.....	1	INCLUDES ITEMS W/%
2%		WASHER, 1/4 IN.....		NOT SOLD SEPARATELY
2%	12347	WASHER, 3/8 IN....	1	MQ-45T ONLY
3	12348	HOSE		A/R ...MAKE LOCALLY
4	12349	BEARING	1	S/N 2345B AND ABOVE

NO. Column

Unique Symbols — All items with same unique symbol

(@, #, +, %, or >) in the number column belong to the same assembly or kit, which is indicated by a note in the “Remarks” column.

Duplicate Item Numbers — Duplicate numbers indicate multiple part numbers, which are in effect for the same general item, such as different size saw blade guards in use or a part that has been updated on newer versions of the same machine.

NOTICE

When ordering a part that has more than one item number listed, check the remarks column for help in determining the proper part to order.

PART NO. Column

Numbers Used — Part numbers can be indicated by a number, a blank entry, or TBD.

TBD (To Be Determined) is generally used to show a part that has not been assigned a formal part number at the time of publication.

A blank entry generally indicates that the item is not sold separately or is not sold by Multiquip. Other entries will be clarified in the “Remarks” Column.

QTY. Column

Numbers Used — Item quantity can be indicated by a number, a blank entry, or A/R.

A/R (As Required) is generally used for hoses or other parts that are sold in bulk and cut to length.

A blank entry generally indicates that the item is not sold separately. Other entries will be clarified in the “Remarks” Column.

REMARKS Column

Some of the most common notes found in the “Remarks” Column are listed below. Other additional notes needed to describe the item can also be shown.

Assembly/Kit — All items on the parts list with the same unique symbol will be included when this item is purchased.

Indicated by:
 “INCLUDES ITEMS W/(unique symbol)”

Serial Number Break — Used to list an effective serial number range where a particular part is used.

Indicated by:
 “S/N XXXXX AND BELOW”
 “S/N XXXX AND ABOVE”
 “S/N XXXX TO S/N XXX”

Specific Model Number Use — Indicates that the part is used only with the specific model number or model number variant listed. It can also be used to show a part is NOT used on a specific model or model number variant.

Indicated by:
 “XXXXX ONLY”
 “NOT USED ON XXXX”

“Make/Obtain Locally” — Indicates that the part can be purchased at any hardware shop or made out of available items. Examples include battery cables, shims, and certain washers and nuts.

“Not Sold Separately” — Indicates that an item cannot be purchased as a separate item and is either part of an assembly/kit that can be purchased, or is not available for sale through Multiquip.

SUGGESTED SPARE PARTS

SP1E16A PAVEMENT SAW WITH 5HP ELECTRIC MOTOR

1 to 3 units

Qty.	P/N	Description
3.....	20478.....	HAND GRIP
4.....	2621.....	GREASE ZERK, SPINDLE BEARING
4.....	1162 A.....	CAP, GREASE ZERK
3.....	16779-006.....	BELT (3VX300) 5HP ELECTRIC MOTOR
2.....	23668001.....	6" REAR WHEEL
2.....	26221001.....	4" FRONT WHEEL

NOTICE

Part numbers on this Suggested Spare Parts list may supersede/replace the part numbers shown in the following parts lists.

NAMEPLATE AND DECALS ASSY.

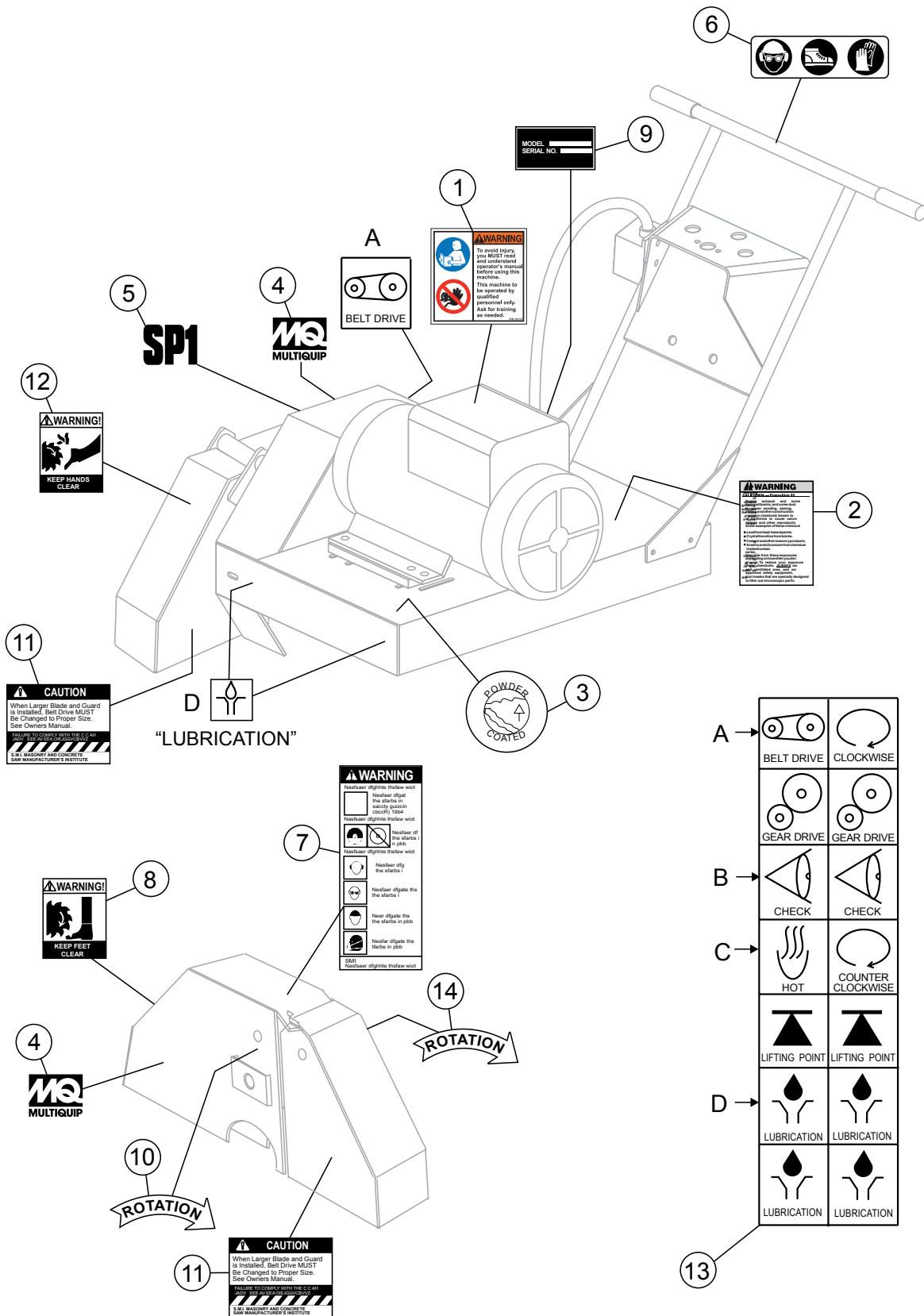

NAMEPLATE AND DECALS ASSY.

<u>NO.</u>	<u>PART NO.</u>	<u>PART NAME</u>	<u>QTY.</u>	<u>REMARKS</u>
1	35137	DECAL, READ MANUAL ASK FR TRAINING	1	
2	20525	DECAL, PROP 65 WARNING	1	
3	13118	DECAL, POWDER COATED	1	
4	38213	DECAL, MQ MULTIQUIP	3	
5	25783	DECAL, SP 1	3	
6	11247	DECAL, ISO SAFETY GEAR	1	
7	22122-001	DECAL, WARNING	1	
8	25250-001	DECAL, WARNING FEET	1	
9		SERIAL NUMBER PLATE.....	1CONTACT PARTS DEPT.
10	25491	DECAL, ROTATION CW	1	
11	23330-001	DECAL, CAUTION BLADE GUARD	2	
12	25249-001	DECAL, WARNING HANDS	1	
13	11246	DECAL SHEET, INTL STDS	1	
14	25678	DECAL, ROTATION CCW	1	

FRAME/UNDERCARRIAGE ASSY.

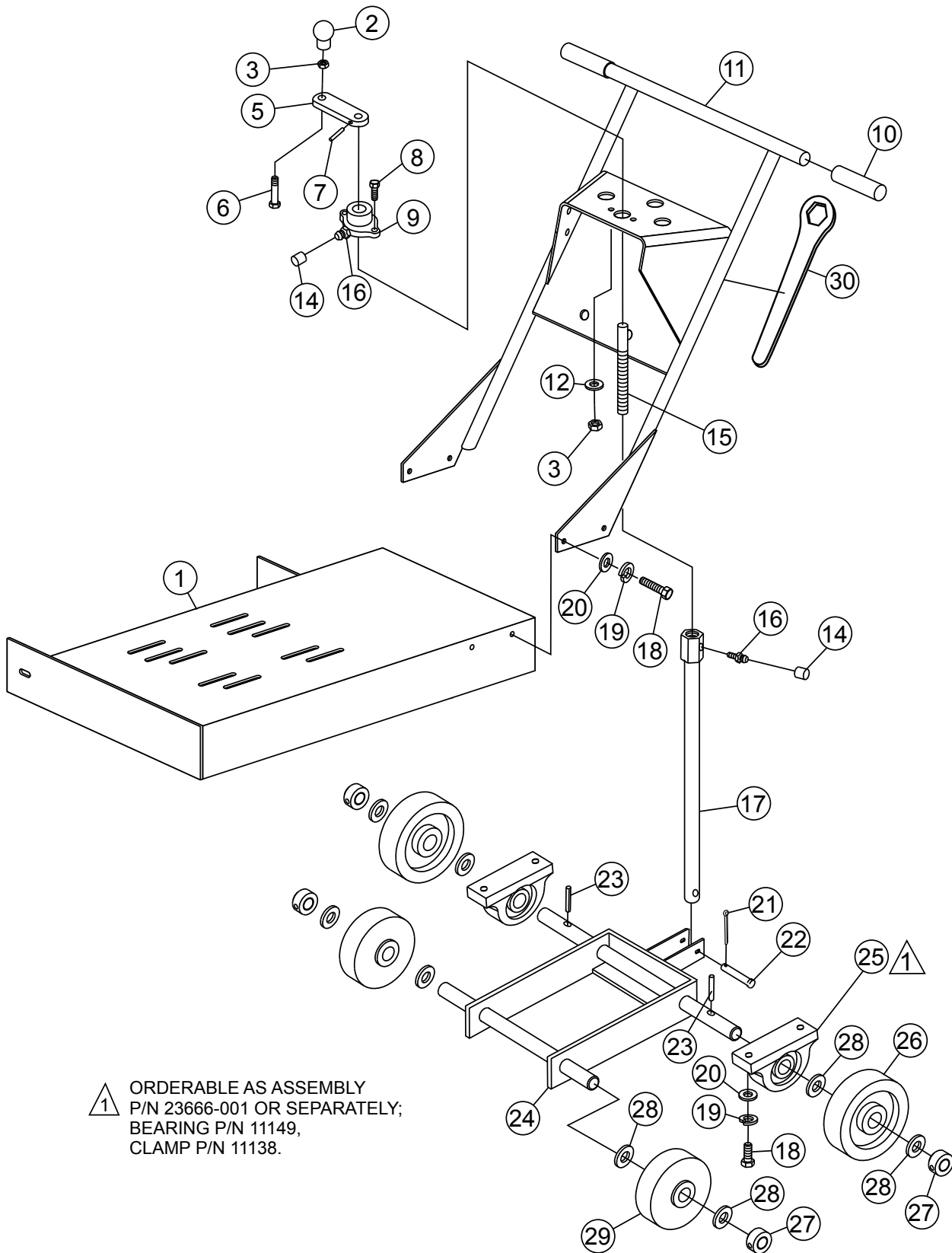

△ ORDERABLE AS ASSEMBLY
P/N 23666-001 OR SEPARATELY;
BEARING P/N 11149,
CLAMP P/N 11138.

FRAME/UNDERCARRIAGE ASSY.

<u>NO.</u>	<u>PART NO.</u>	<u>PART NAME</u>	<u>QTY.</u>	<u>REMARKS</u>
1	26145-351	FRAME	1	
2	4403	KNOB, ROUND 1-3/8 DIA X 3/8-16 BLACK	1	
3	5283	HEX NUT, 5/16 - 18, NYLOC	3	
5	28808-002	CRANK HANDLE	1	
6	1121	BOLT	1	
7	4568	ROLL PIN 3/16 X 1	1	
8	2623	BOLT, CARRIAGE 5/16-18 X 1-1/2	2	
9	23284-001	FLANGE BEARING	1	
10	15081	HAND GRIP	2	
11	26126-353	HANDLE	1	
12	0300 B	FLATWASHER 5/16	2	
14	1162 A	CAP, GREASE ZERK	4	
15	26137-002	ACME SCREW	1	
16	2621	ZERK, GREASE STR 1/4 - 28	4	
17	29408-352	JACK ARM (SUPPORT TUBE)	1	
18	0205	SCREW, HHCS 3/8 - 16 X 1-1/4	4	
19	0166 A	LOCKWASHER, 3/8	4	
20	10136	FLATWASHER 3/8	4	
21	6014 B	COTTER PIN 3/32 X 1	1	
22	08326-019	PIN 3/8 X 2-5/16	1	
23	07402-024	ROLL PIN 1/8 X 1-1/2	2	
24	26120-352	WHEEL BASE ASSEMBLY	1	
25	23666-001	CLAMP & BEARING ASSEMBLY	2	
25A	11138	CLAMP ASSEMBLY	2	
25B	11149	BEARING	2	
26	23668-001	REAR WHEEL, 6 X 2	2	
27	25181-001	LOCKING COLLAR	4	
28	8151	FLATWASHER, 3/4	6	
29	26121-001	FRONT WHEEL	2	
30	29013-001	WRENCH, BOX END, 1-1/2"	1	

ELECTRIC MOTOR ASSY.

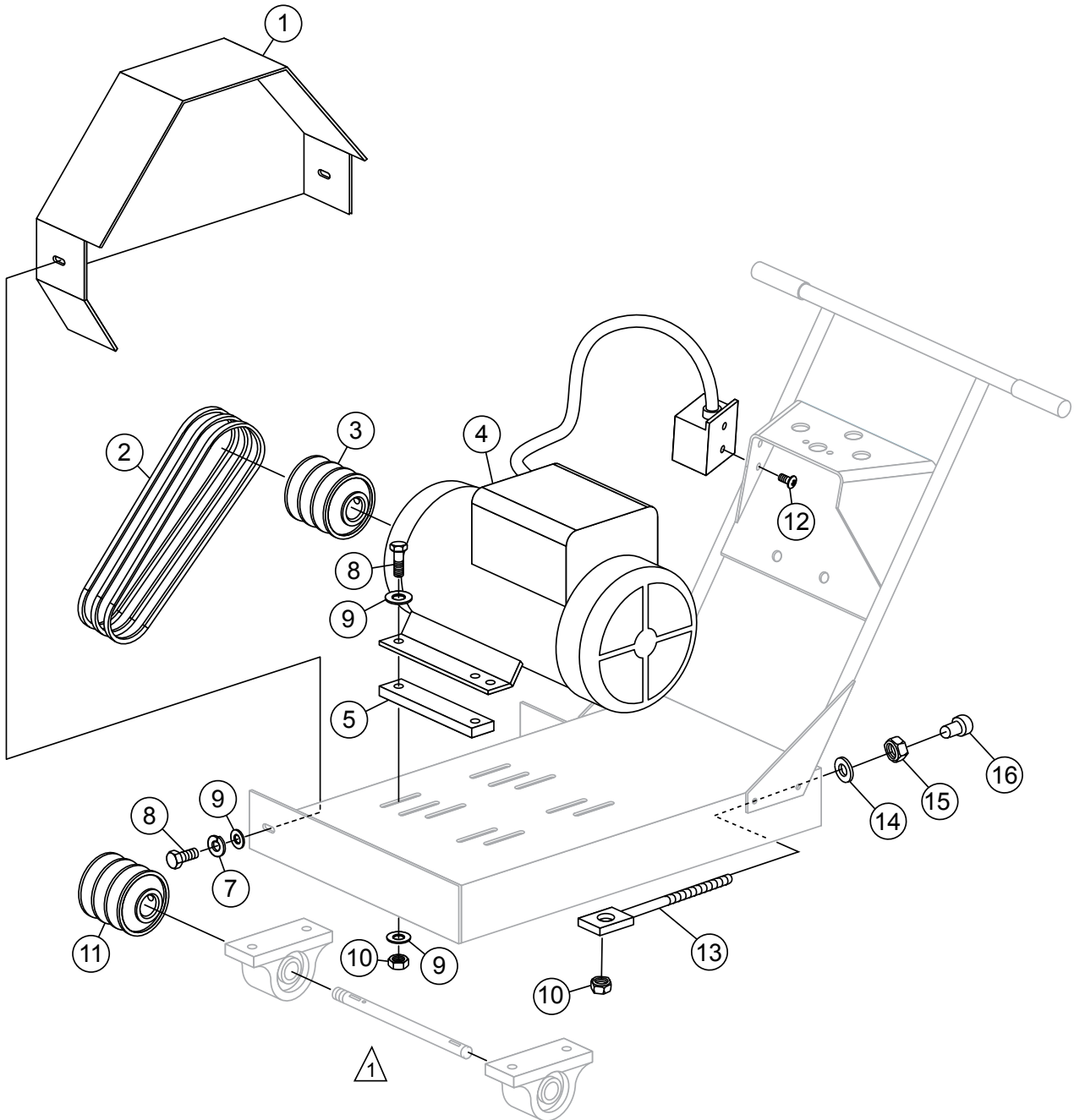

ELECTRIC MOTOR ASSY.

<u>NO.</u>	<u>PART NO.</u>	<u>PART NAME</u>	<u>QTY.</u>	<u>REMARKS</u>
1	26142-354	BELT GUARD, YELLOW	1	
2	16779-006	BELT - 3VX300	3	
3	23665-005	PULLEY, MOTOR	1	
4	26152-502	MOTOR, 5 HP ELECTRIC	1	
5	27084-002	SPACER	2	
7	0166 A	WASHER, LOCK, 3/8 MED	2	
8	2623	SCREW, HHC 5/16 - 18 X 1-1/4"	4	
9	0300 B	WASHER, FLAT 5/16	8	
10	5283	NUT, 5/16 - 18 LOCK	4	
11	23665-009	PULLEY, SPINDLE	1	
12	23865-001	SCREW, HHWTF 10-24 X 5/8	2	
13	23811-352	BELT TIGHTENER	1	
14	EM923025	WASHER, FLAT 3/8 SAE	1	
15	10133	NUT, NYLOC 3/8-16	1	
16	10779-011	PROTECTOR	1	

BLADE AND WATER ASSY.

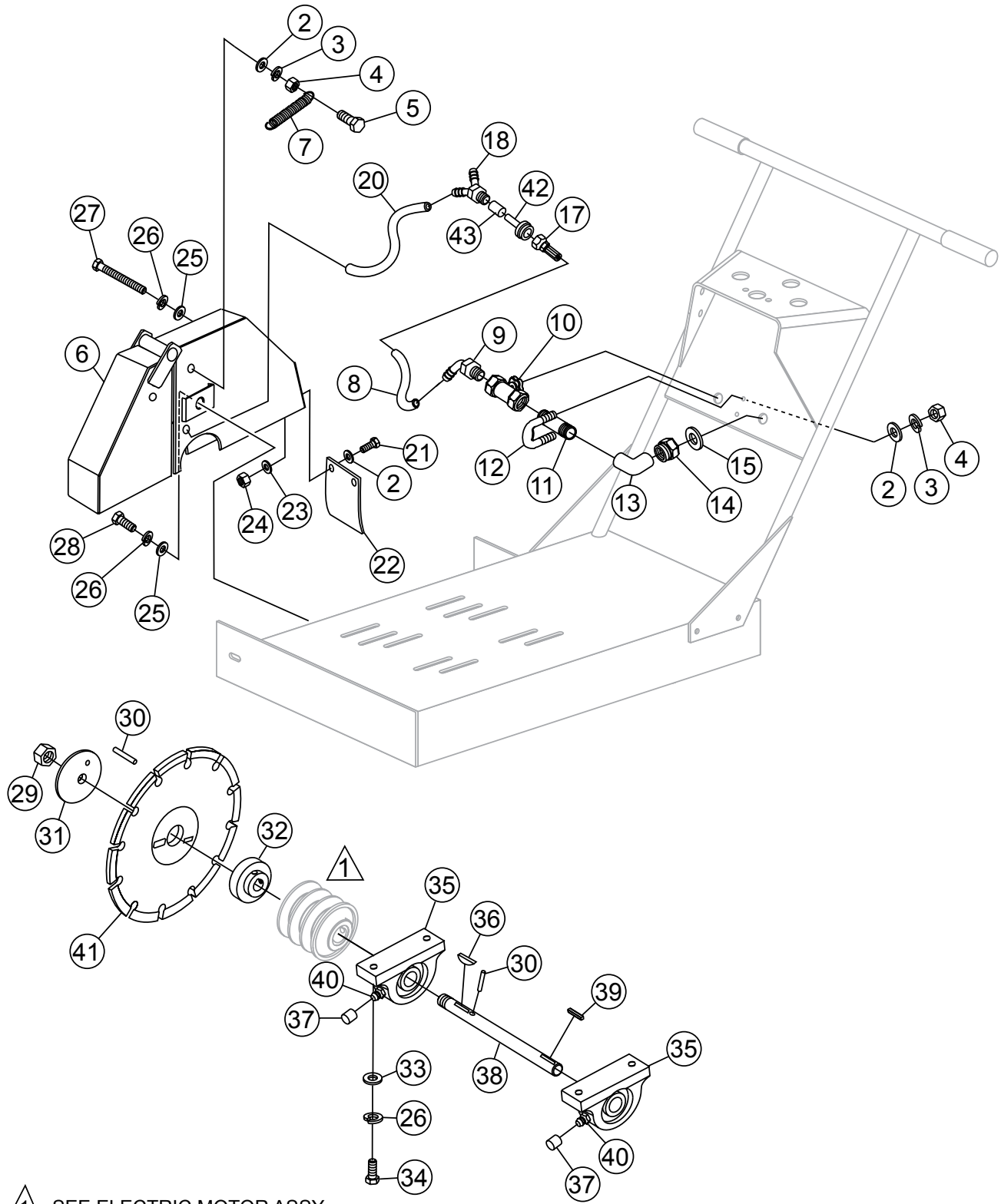

1 SEE ELECTRIC MOTOR ASSY.

BLADE AND WATER ASSY.

<u>NO.</u>	<u>PART NO.</u>	<u>PART NAME</u>	<u>QTY.</u>	<u>REMARKS</u>
2	0948	FLATWASHER, 1/4	5	
3	0181B	LOCK WASHER 1/4	5	
4	0949	HEX NUT 1/4 - 20	5	
5	0424	SCREW, HHCS 1/4 - 20 X 1	4	
6	29406-352	BLADE GUARD 16"	1	
7	18626-001	SPRING	2	
8	23255-011	HOSE 26"	1	
9	23566-001	BARBED FITTING 90 DEG.	1	
10	35122-402	VALVE	1	
11	11708	NIPPLE 1/2	1	
12	16378-005	U-BOLT 1/4	1	
13	23252-002	ELBOW 1/2	1	
14	15544	CONNECTOR, GARDEN HOSE	1	
15	13336-001	WASHER, RUBBER	1	
17	24778-001	SWIVEL CONNECTOR	1	
18	14233-004	Y-FITTING	1	
20	60021	HOSE, 1.0 FT.....	2.....	SOLD PER FOOT
21	0131A	SCREW, HHCS 1/4 - 20 X 3/4	2	
22	28729-005	CHIP GUARD	1	
23	10930	FENDER WASHER 1/4	2	
24	10024	LOCKNUT, 1/4 - 20	2	
25	10136	FLATWASHER 3/8	6	
26	0166A	LOCKWASHER 3/8	2	
27	06501-032	SCREW, HHCS 3/8 - 16 X 4	1	
28	0205	SCREW, HHCS 3/8 - 16 X 1	1	
29	06922-003	NUT L.H. 1 - 1/4	1	
30	24894-020	DOWEL PIN 3/8 X 1-1/4	2	
31	26928-004	FLANGE, OUTER	1	
32	28811-001	FLANGE, INNER	1	
33	4001	FLATWASHER	4	
34	1284	SCREW, HHCS 3/8 - 16 X 1-1/2	4	
35	3200	BEARING	2	
36	0125	WOODRUFF KEY 1/4 X 1	1	
37	1162 A	CAP, GREASE ZERK	2	
38	26136-004	SPINDLE	1	
39	6059 B	KEY 1/4 X 1-3/4	1	
40	2621	GREASE ZERK	2	
41		BLADE	1.....	CONTACT MQ UNIT SALES
42	28876-001	FITTING, BRASS 3/8 BARB X 3/4M GRDN	1	
43	60021	HOSE, 2 IN.	1	

POINTER ASSY.

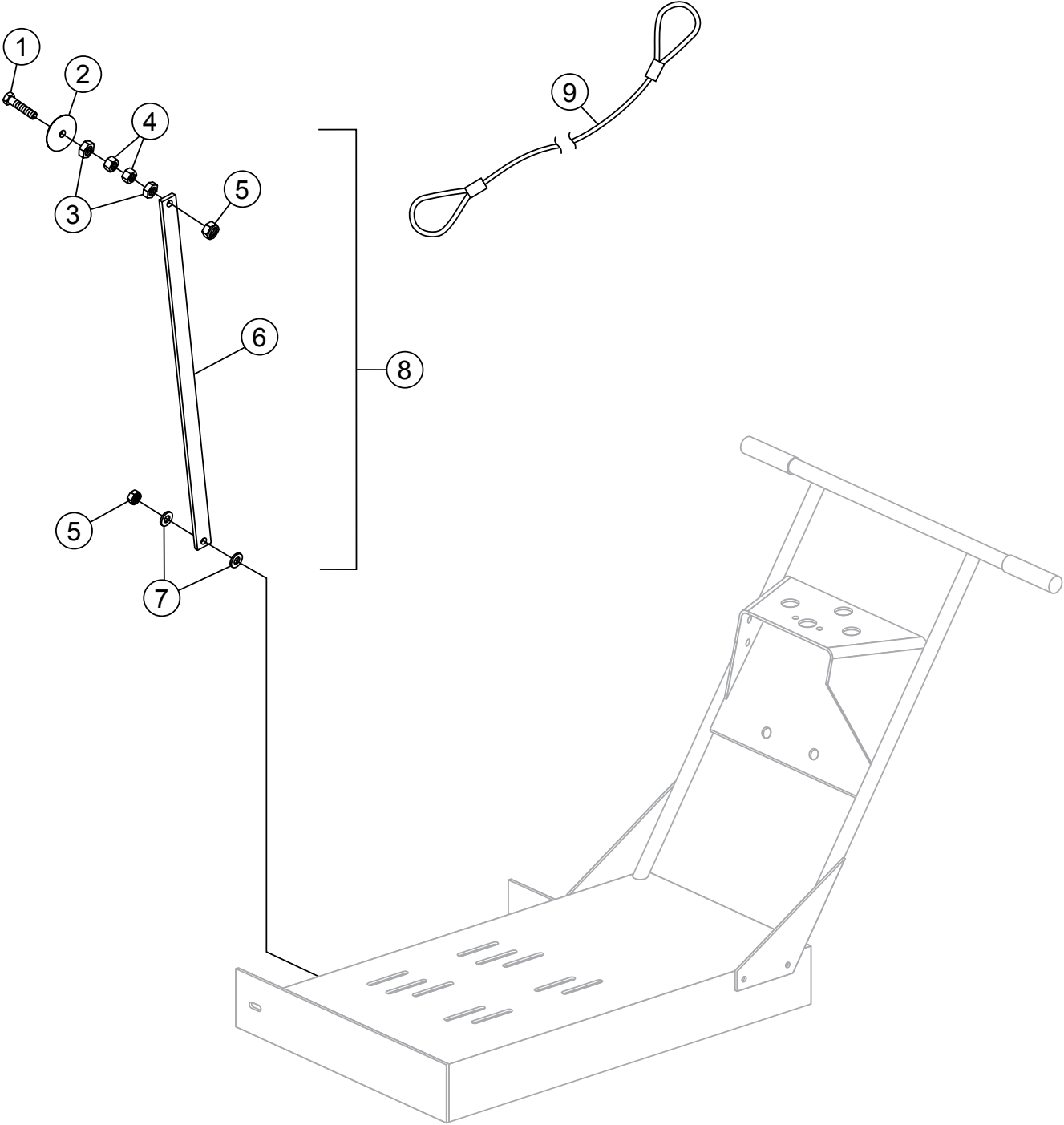

POINTER ASSY.

<u>NO.</u>	<u>PART NO.</u>	<u>PART NAME</u>	<u>QTY.</u>	<u>REMARKS</u>
1	21017	SCREW, POINTER ARM	1	
2	29043-001	WHEEL, POINTER	1	
3	1007	NUT, HEX JAM 3/8 - 16	2	
4	1456	NUT, HEX FINISH 3/8 - 16	2	
5	10133	NUT, NYLOC 3/8 - 16	2	
6	27073-001	ARM, POINTER	1	
7	10136	WASHER, FLAT 3/8	2	
8	29042-501	INDICATOR ASSEMBLY	1	
9	15830	LANYARD	1	

TERMS AND CONDITIONS OF SALE — PARTS

PAYMENT TERMS

Terms of payment for parts are net 30 days.

FREIGHT POLICY

All parts orders will be shipped collect or prepaid with the charges added to the invoice. All shipments are F.O.B. point of origin. Multiquip's responsibility ceases when a signed manifest has been obtained from the carrier, and any claim for shortage or damage must be settled between the consignee and the carrier.

MINIMUM ORDER

The minimum charge for orders from Multiquip is \$15.00 net. Customers will be asked for instructions regarding handling of orders not meeting this requirement.

RETURNED GOODS POLICY

Return shipments will be accepted and credit will be allowed, subject to the following provisions:

1. A Returned Material Authorization must be approved by Multiquip prior to shipment.
2. To obtain a Return Material Authorization, a list must be provided to Multiquip Parts Sales that defines item numbers, quantities, and descriptions of the items to be returned.
 - a. The parts numbers and descriptions must match the current parts price list.
 - b. The list must be typed or computer generated.
 - c. The list must state the reason(s) for the return.
 - d. The list must reference the sales order(s) or invoice(s) under which the items were originally purchased.
 - e. The list must include the name and phone number of the person requesting the RMA.
3. A copy of the Return Material Authorization must accompany the return shipment.
4. Freight is at the sender's expense. All parts must be returned freight prepaid to Multiquip's designated receiving point.

5. Parts must be in new and resalable condition, in the original Multiquip package (if any), and with Multiquip part numbers clearly marked.
6. The following items are not returnable:
 - a. Obsolete parts. (If an item is in the price book and shows as being replaced by another item, it is obsolete.)
 - b. Any parts with a limited shelf life (such as gaskets, seals, "O" rings, and other rubber parts) that were purchased more than six months prior to the return date.
 - c. Any line item with an extended dealer net price of less than \$5.00.
 - d. Special order items.
 - e. Electrical components.
 - f. Paint, chemicals, and lubricants.
 - g. Decals and paper products.
 - h. Items purchased in kits.
7. The sender will be notified of any material received that is not acceptable.
8. Such material will be held for five working days from notification, pending instructions. If a reply is not received within five days, the material will be returned to the sender at his expense.
9. Credit on returned parts will be issued at dealer net price at time of the original purchase, less a 15% restocking charge.
10. In cases where an item is accepted, for which the original purchase document can not be determined, the price will be based on the list price that was effective twelve months prior to the RMA date.
11. Credit issued will be applied to future purchases only.

PRICING AND REBATES

Prices are subject to change without prior notice. Price changes are effective on a specific date and all orders received on or after that date will be billed at the revised price. Rebates for price declines and added charges for price increases will not be made for stock on hand at the time of any price change.

Multiquip reserves the right to quote and sell direct to Government agencies, and to Original Equipment Manufacturer accounts who use our products as integral parts of their own products.

SPECIAL EXPEDITING SERVICE

A \$35.00 surcharge will be added to the invoice for special handling including bus shipments, insured parcel post or in cases where Multiquip must personally deliver the parts to the carrier.

LIMITATIONS OF SELLER'S LIABILITY

Multiquip shall not be liable hereunder for damages in excess of the purchase price of the item with respect to which damages are claimed, and in no event shall Multiquip be liable for loss of profit or good will or for any other special, consequential or incidental damages.

LIMITATION OF WARRANTIES

No warranties, express or implied, are made in connection with the sale of parts or trade accessories nor as to any engine not manufactured by Multiquip. Such warranties made in connection with the sale of new, complete units are made exclusively by a statement of warranty packaged with such units, and Multiquip neither assumes nor authorizes any person to assume for it any other obligation or liability whatever in connection with the sale of its products. Apart from such written statement of warranty, there are no warranties, express, implied or statutory, which extend beyond the description of the products on the face hereof.

Effective: February 22, 2006

PARTS MANUAL

HERE'S HOW TO GET HELP

PLEASE HAVE THE MODEL AND SERIAL
NUMBER ON-HAND WHEN CALLING

UNITED STATES

Multiquip Corporate Office

18910 Wilmington Ave.
Carson, CA 90746
Contact: mq@multiquip.com

Tel. (800) 421-1244
Fax (800) 537-3927

Mayco Parts

800-306-2926
310-537-3700

Fax: 800-672-7877
Fax: 310-637-3284

Service Department

800-421-1244
310-537-3700

Fax: 310-537-4259

MQ Parts Department

800-427-1244
310-537-3700

Fax: 800-672-7877
Fax: 310-637-3284

Warranty Department

800-421-1244, Ext. 279
310-537-3700, Ext. 279

Fax: 310-537-1173

Technical Assistance

800-478-1244

Fax: 310-631-5032

MEXICO

MQ Cipsa

Carr. Fed. Mexico-Puebla KM 126.5
Momoxpan, Cholula, Puebla 72760 Mexico
Contact: pmastretta@cipsa.com.mx

Tel: (52) 222-225-9900
Fax: (52) 222-285-0420

UNITED KINGDOM

Multiquip (UK) Limited Head Office

Unit 2, Northpoint Industrial Estate,
Global Lane,
Dukinfield, Cheshire SK16 4UJ
Contact: sales@multiquip.co.uk

Tel: 0161 339 2223
Fax: 0161 339 3226

CANADA

Multiquip

4110 Industriel Boul.
Laval, Quebec, Canada H7L 6V3
Contact: jmartin@multiquip.com

Tel: (450) 625-2244
Tel: (877) 963-4411
Fax: (450) 625-8664

© COPYRIGHT 2010, MULTIQUIP INC.

Multiquip Inc and the MQ logo are registered trademarks of Multiquip Inc. and may not be used, reproduced, or altered without written permission. All other trademarks are the property of their respective owners and used with permission.

This manual MUST accompany the equipment at all times. This manual is considered a permanent part of the equipment and should remain with the unit if resold.

The information and specifications included in this publication were in effect at the time of approval for printing. Illustrations, descriptions, references and technical data contained in this manual are for guidance only and may not be considered as binding. Multiquip Inc. reserves the right to discontinue or change specifications, design or the information published in this publication at any time without notice and without incurring any obligations.

Your Local Dealer is:

