

PARTS AND OPERATION MANUAL



WRS-5200 Ride-On Roller Screed (CHINA)

© COPYRIGHT 2001, MULTIQUIP INC.

Revision #1 (12/14/01)



MULTIQUIP INC.

18910 WILMINGTON AVE.
CARSON, CALIFORNIA 90746
310-537-3700
800-421-1244
FAX:310-537-3927

E-mail:mq@multiquip.com • **www:**www.multiquip.com

PARTS DEPARTMENT:

800-427-1244
FAX: 800-672-7877
SERVICE DEPARTMENT/TECHNICAL ASSISTANCE:
800-478-1244
FAX:310-631-5032

Atlanta • Boise • Dallas • Houston • Newark
Montreal, Canada • Manchester, UK
Rio De Janiero, Brazil • Guadalajara, Mexico



WARNING



CALIFORNIA — Proposition 65 Warning

Engine exhaust and some of its constituents, and some dust created by power sanding, sawing, grinding, drilling and other construction activities contains chemicals known to the State of California to cause cancer, birth defects and other reproductive harm. Some examples of these chemicals are:

- Lead from lead-based paints.
- Crystalline silica from bricks.
- Cement and other masonry products.
- Arsenic and chromium from chemically treated lumber.

Your risk from these exposures varies, depending on how often you do this type of work. To reduce your exposure to these chemicals: **ALWAYS** work in a well ventilated area, and work with approved safety equipment, such as dust masks that are specially designed to filter out microscopic particles.

HERE'S HOW TO GET HELP

*PLEASE HAVE THE MODEL AND SERIAL NUMBER
ON-HAND WHEN CALLING*

PARTS DEPARTMENT

800/427-1244 or 310/537-3700

FAX: 800/672-7877 or 310/637-3284

SERVICE DEPARTMENT

800/478-1244 or 310/537-3700

FAX: 310 - 537-4259

WARRANTY DEPARTMENT

800/421-1244, EXT. 279 or 310/537-3700

FAX: 310 - 537-1173

MAIN

800/421-1244 or 310/537-3700

FAX: 310 - 537-3927

**WRS-5200 RIDE-ON ROLLER
SCREED.**

Here's How To Get Help 3
 Table Of Contents 4
 Training Checklist 5
 Daily Pre-Operational Checklist 6
 Parts Ordering Procedures 7
 Operation and Safety Decals 8
 Specifications 9
 Safety Message Alert Symbols 10-11
 Rules for Safe Operation 12-13
 Features 14
 Assembly Instructions 15-21
 Machine Controls 22-23
 Machine Start-up and Operation 24-25
 Maintenance and Adjustment Procedures 26-27
 Suggested Training 28-29
 Form Specifications 30
 Screed Rails 31
 18 and 22 Foot Screed Lengths 32
 26 and 28 Foot Screed Lengths 33
 30 and 32 Foot Screed Lengths 34
 36 and 40 Foot Screed Lengths 35
 44 Foot Screed Lengths 36
 48 and 52 Foot Screed Lengths 37

Assembly Drawings

Frame Asssembly (Operator End) 38-39
 Frame Asssembly (Engine End) 40-43
 Control Panel Asssembly 44-47
 Engine Assembly 48-51
 Frame Assembly 52-55
 Hydraulic Assembly 56-59
 Pressure Washer Assembly 60-61

Wiring Diagram

Wiring Diagram 62-63

Terms and Conditions Of Sale — Parts 64

NOTE

*Specification and part number
are subject to change without
notice.*

TRAINING CHECKLIST

TRAINING CHECKLIST			
NO.	DESCRIPTION	OK?	DATE
1	Read Operator's Manual completely.		
2	Machine layout, location of components, checking of engine and gearbox oil levels.		
3	Fuel system, refueling procedure.		
4	Operation of spray and lights (if equipped).		
5	Operation of controls (machine not running).		
6	Safety controls, seat kill switch operation.		
7	Emergency stop procedures.		
8	Chain adjustment procedures.		
9	Chain changing procedures.		
10	Startup of machine, engine choke throttle.		
11	Maneuvering with drive tubes.		
12	Strike tube operation.		
13	Adjustment of crown and camber turnbuckles.		
14	Shutdown procedure.		
15	Lifting of machine (lift loops).		
16	Machine transport and storage.		
17	Operation of pressure washer.		
18	Cleanup procedure.		

Operator _____ Trainee _____

COMMENTS:

DAILY PRE-OPERATION CHECKLIST

DAILY PRE-OPERATION CHECKLIST						
DAY	ENGINE OIL	FILL GAS TANK	OPERATION HOURS	OPERATOR (INITIALS)	CLEANED BY (INITIALS)	COMMENTS
1						
2						
3						
4						
5						
6						
7						
8						
9						
10						
11						
12						
13						
14						
15						
16						
17						
18						
19						
20						
21						
22						
23						
24						
25						
26						
27						
28						
29						
30						
31						

Operator _____ Trainee _____

COMMENTS:

- Dealer account number
- Dealer name and address
- Shipping address (if different than billing address)
- Return fax number
- Applicable model number
- Quantity, part number and description of each part
- Specify preferred method of shipment:
 - UPS Ground
 - UPS Second Day or Third Day*
 - UPS Next Day*
 - Federal Express Priority One (please provide us with your Federal Express account number)*
 - Airborne Express*
 - Truck or parcel post

**Normally shipped the same day the order is received, if prior to 2PM west coast time.*

Earn Extra Discounts when you order by FAX!

All parts orders which include complete part numbers and are received by fax qualify for the following extra discounts:

<u>Number of line items ordered</u>	<u>Additional Discount</u>
1-9 items	3%
10+ items**	5%

Get special freight allowances when you order 10 or more line items via FAX!**

- UPS Ground Service at no charge for freight
- PS Third Day Service at one-half of actual freight cost

No other allowances on freight shipped by any other carrier.

**Common nuts, bolts and washers (all items under \$1.00 list price) do not count towards the 10+ line items.

DISCOUNTS ARE SUBJECT TO CHANGE

Fax order discount and UPS special programs revised June 1, 1995

**Extra Fax Discount
for Domestic USA
Dealers Only**

**Up to 5%
extra savings!**

**UPS
Special**
For faxed orders only

**Now! Direct TOLL-FREE access
to our Parts Department!**

Toll-free nationwide:

800-421-1244









Toll-free FAX:

800/6-PARTS-7 • 800-672-7877

OPERATION AND SAFETY DECALS

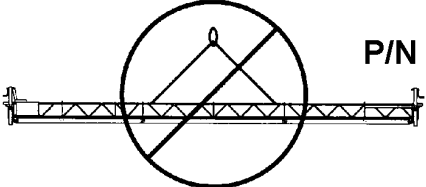
Machine Safety Decals

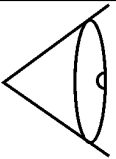
The WRS-5200 Ride-On Roller Screed is equipped with a number of safety decals. These decals are provided for operator safety and maintenance information. The illustration below and on the next page shows these decals as they appear on the machine. Should any of these decals become unreadable, replacements can be obtained from your dealer.

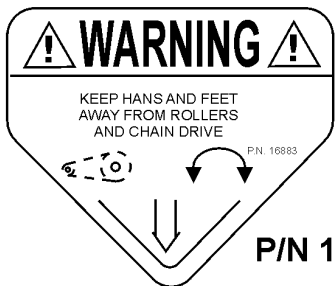
OPERATION AND SAFETY DECALS	
	<p>Symbol for CAUTION. When this symbol is displayed in the manual or on the machine be aware that there is a potential for personal injury or damage to the equipment. Always follow instructions for safe operation and use.</p>
	<p>Symbol indicates that it is mandatory to wear safety glasses, safety helmet and ear protection.</p> <p>P/N 11247 (Part of decal kit 12620)</p>
	<p>Symbol indicates that it is mandatory to wear gloves.</p> <p>P/N 11247 (Part of decal kit 12620)</p>
	<p>Symbol indicates that it is mandatory to wear safety shoes, with extra protection (steel toed).</p> <p>P/N 11247 (Part of decal kit 12620)</p>
<p style="text-align: center;">CONTACT MULTIQUIP SERVICE DEPT.</p> <div style="border: 1px solid black; width: 100px; margin: auto; padding: 5px;"> <p style="text-align: center; margin: 0;">NAMEPLATE</p> <hr style="border: 0; border-top: 1px solid black; margin: 2px 0;"/> <hr style="border: 0; border-top: 1px solid black; margin: 2px 0;"/> <hr style="border: 0; border-top: 1px solid black; margin: 2px 0;"/> </div>	
 <p style="text-align: right;">P/N 16880</p> <p>LIFTING STRAPS SHOULD NEVER BE ATTACHED TO CENTER SECTIONS OF THE SCREED. LIFTING POINTS ARE INDICATED AT EACH END OF THE SCREED.</p>	<div style="border: 1px solid black; padding: 10px; margin-bottom: 10px;">  <p>Lift point symbol. Symbol indicates where machine should be lifted.</p> <p>P/N 11246 (Part of decal kit 12620)</p> </div> <div style="border: 1px solid black; padding: 10px; margin-bottom: 10px;">  <p>Lubrication symbol. Know that wherever you see this symbol on the machine, a lubrication point will be called out.</p> <p>P/N 11246 (Part of decal kit 12620)</p> </div> <div style="border: 1px solid black; padding: 10px; margin-bottom: 10px;">  <p>Symbol for examining or checking of the machine. Mostly used for maintenance.</p> <p>P/N 11246 (Part of decal kit 12620)</p> </div> <div style="border: 1px solid black; padding: 10px; margin-bottom: 10px;">  <p>Radiating heat symbol. Symbol indicates equipment is hot.</p> <p>P/N 11246 (Part of decal kit 12620)</p> </div> <div style="border: 1px solid black; padding: 10px; margin-bottom: 10px;">  <p style="text-align: right;">P/N 16883</p> </div> <p>LOCATED ON EACH END OF THE ROLLER SCREED ARE CHAIN DRIVES AND DRIVE ROLLERS THAT MOVE FORWARD AND BACKWARD. KEEP PEOPLE AWAY FROM THESE AREAS.</p>

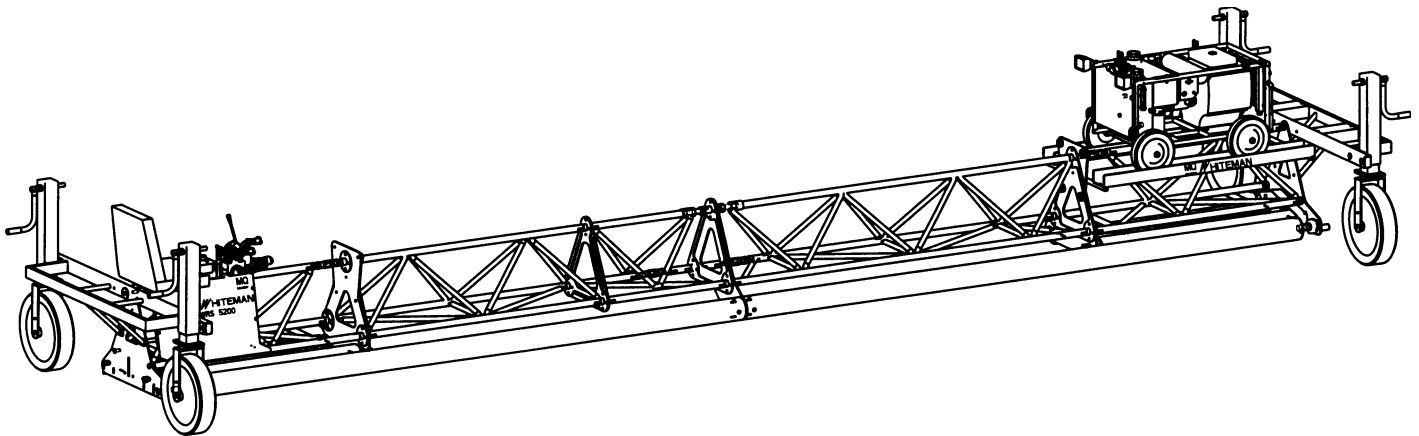

Figure 1. WRS-5200 Ride-On Roller Sced

TABLE 1. ROLLER SCRED SPECIFICATIONS	
Length (Max 9 Sections)	52 FT. (15.84 meters)
Width (At Ends)	7 FT. (2.1meters)
Weight (Max. Length)	1,500 LBS (680 kg.)
Weight (Power Unit)	500 LBS. (227 kg)
Strike Tube Speed	Max 450 RPM
Drive Tube Speed	Max. 150 RPM
Hydraulic Operating Pressure	Max. 2000 PSI
Hydraulic Oil	AW MV ISO 46
Engine	20 HP Onan
Fuel	Unleaded Gasoline

WMS MULTI-USE SCREED — SAFETY MESSAGE ALERT SYMBOLS

FOR YOUR SAFETY AND THE SAFETY OF OTHERS!

Safety precautions should be followed at all times when operating this equipment. Failure to read and understand the Safety Messages and Operating Instructions could result in injury to yourself and others.

NOTE

This Owner's Manual has been developed to provide complete instructions for the safe and efficient operation of the Multiquip Model WRS-5200 Ride-On Roller Screed. Refer to the engine manufacturers instructions for data relative to its safe operation.

Before using this mini-screed, ensure that the operating individual has read and understands all instructions in this manual.

SAFETY MESSAGE ALERT SYMBOLS

The three (3) Safety Messages shown below will inform you about potential hazards that could injure you or others. The Safety Messages specifically address the level of exposure to the operator, and are preceded by one of three words: **DANGER**, **WARNING**, or **CAUTION**.



DANGER: You **WILL** be **KILLED** or **SERIOUSLY** injured if you do not follow directions.



WARNING: You **CAN** be **KILLED** or **SERIOUSLY** injured if you do not follow directions.



CAUTION: You **CAN** be injured if you do not follow directions.

Potential hazards associated with WRS-5200 Ride-On Roller Screed operation will be referenced with Hazard Symbols which appear throughout this manual, and will be referenced in conjunction with Safety Message Alert Symbols.

HAZARD SYMBOLS



Engine exhaust gases contain poisonous carbon monoxide. This gas is colorless and odorless, and can cause death if inhaled. **NEVER** operate this equipment in a confined area or enclosed structure that does not provide ample free flow air.



Explosive Fuel

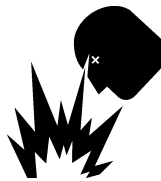

GASOLINE is extremely flammable, and its vapors can cause an explosion if ignited. **DO NOT** start the engine near spilled fuel or combustible fluids. **DO NOT** fill the fuel tank while the engine is running or hot. **DO NOT** overfill tank, since spilled fuel could ignite if it comes into contact with hot engine parts or sparks from the ignition system. Store fuel in approved containers, in well-ventilated areas and away from sparks and flames. **NEVER** use fuel as a cleaning agent.



Burn Hazards



Engine components can generate extreme heat. To prevent burns, **DO NOT** touch these areas while the engine is running or immediately after operations. Never operate the engine with heat shields or heat guards removed.



Rotating Parts



NEVER operate equipment with covers, or guards removed. Keep fingers, hands, hair and clothing away from all moving parts to prevent injury.

WMS MULTI-USE SCREED — SAFETY MESSAGE ALERT SYMBOLS



Accidental Starting



OFF

ALWAYS place the engine ON/OFF switch in the **OFF** position, and remove the ignition key when the machine is not in use.



Respiratory Hazard



ALWAYS wear approved respiratory protection.



Sight and Hearing hazard

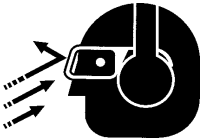

ALWAYS wear approved eye and hearing protection.



Equipment Damage Messages

Other important messages are provided throughout this manual to help prevent damage to your trash pump, other property, or the surrounding environment.

NOTE

This mini-screed, other property, or the surrounding environment could be damaged if you do not follow instructions.

CAUTION:



Failure to follow instructions in this manual may lead to serious injury or even death! This equipment is to be operated by trained and qualified personnel only! This equipment is for industrial use only.

The following safety guidelines should always be used when operating the WRS-5200 Ride-On Roller Screed.

GENERAL SAFETY

- **DO NOT** operate or service this equipment before reading this entire manual.



- This equipment should not be operated by persons under 18 years of age.

- **NEVER** operate this equipment without proper protective clothing, shatterproof glasses, steel-toed boots and other protective devices required by the job.



- **NEVER** operate this equipment when not feeling well due to fatigue, illness or taking medicine.



- **NEVER** operate this equipment under the influence of drugs or alcohol.



- **NEVER** use accessories or attachments, which are not recommended by Multiquip for this equipment. Damage to the equipment and/or injury to user may result.

- Manufacturer does not assume responsibility for any accident due to equipment modifications.

- Whenever necessary, replace nameplate, operation and safety decals when they become difficult read.

- **ALWAYS** check the machine for loosened threads or bolts before starting.

- **ALWAYS** try to do most work during daylight hours or with sufficient artificial lighting. Visibility must be good for this machine to be used effectively and safely.

- Check the safety kill switch. It is recommended to test the engine kill switch prior to each use to ensure the switch is operating properly.

- **NEVER** touch the hot exhaust manifold, muffler or cylinder. Allow these parts to cool before servicing engine or trowel.



- **High Temperatures** – Allow the engine to cool before adding fuel or performing service and maintenance functions. Contact with *hot* components can cause serious burns.

- The power unit's engine requires an adequate free flow of cooling air. **NEVER** operate the screed in any enclosed or narrow area where free flow of the air is restricted. If the air flow is restricted it will cause serious damage to the machine or engine and may cause injury to people. Remember the machine's engine gives off **DEADLY** carbon monoxide gas.

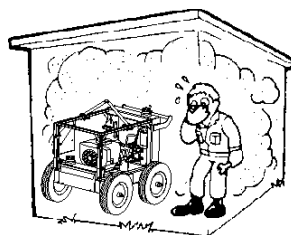

- **ALWAYS** refuel in a well-ventilated area, away from sparks and open flames.

- **ALWAYS** use extreme caution when working with flammable liquids. When refueling, stop the engine and allow it to cool. **DO NOT** smoke near the screed. Fire or explosion could result from fuel vapors, or if fuel is spilled on a hot engine.

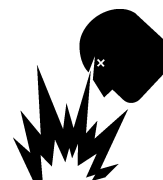

- **NEVER** operate the screed in an explosive atmosphere or near combustible materials. An explosion or fire could result causing severe *bodily harm or even death*.

- Topping-off to filler port is dangerous, as it tends to spill fuel.

- **NEVER** store the machine with fuel in the tank for an extended period of time. Always clean up spilled fuel immediately!

WRS-5200 — RULES FOR SAFE OPERATION

The following safety guidelines should always be used when operating the WRS-5200 Screed:

GENERAL SAFETY

- **DO NOT** operate this equipment unless all guards and safety devices are attached and in place.
- Use proper heavy lifting techniques when moving equipment. This screed is very heavy. It should be lifted only with a lifting device (i.e. crane, forklift, etc.) with a lifting capacity of at least one ton.
- Check to make sure that the operating area is clear before starting the engine.
- **ALWAYS** have throttle at idle position while starting the engine.
- **ALWAYS** keep clear of rotating or moving parts while operating this equipment.
- **NEVER** leave the machine **unattended** while running.
- Refuel in a well-ventilated area, away from sparks and open flames.
- **Moving Parts** - Shut down the engine and disconnect battery before performing service or maintenance functions. Contact with moving parts can cause serious injury.
- Unauthorized equipment modifications will void all warranties.
- Disconnect battery and spark plug wires before attempting service.

CAUTION: Temperatures



- **High Temperatures** – Allow the machine and engine to cool before adding fuel or performing service and maintenance functions. Contact with **hot** components can cause serious burns.

CAUTION: Emergencies



- Always know the location of the nearest **fire extinguisher** and **first aid kit**. Know the location of the nearest telephone. Also know the phone numbers of the nearest **ambulance**, **doctor** and **fire department**. This information will be invaluable in the case of an emergency.

MAINTENANCE SAFETY

- Disconnect the battery and spark plug wires before attempting any type of service.
- Securely support any machine components that must be raised.
- **NEVER** lubricate components or attempt service on a running machine.
- Allow the machine a proper amount of time to cool before servicing.
- Keep the machinery in proper running condition.
- Make sure that there is no buildup of concrete, grease, oil or debris on the machine.
- Fix damage to the machine immediately and always replace broken parts.
- Dispose of hazardous waste properly. Examples of potentially hazardous waste are used motor oil, fuel and fuel filters.
- **DO NOT** use food or plastic containers to dispose of hazardous waste.
- **DO NOT** pour waste, oil or fuel directly onto the ground, down a drain or into any water source.

Lifting the Screed and Power unit **DANGER:**

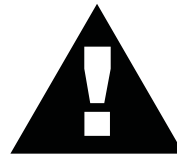

- When lifting of the screed or power unit is required, **NEVER** stand underneath the screed or power unit. The possibility exist that severe bodily harm or even death may occur.

- Use straps of adequate lifting capacity to lift the drive roller and strike tube.
- To lift the power unit, attach a crane or lifting device of adequate lifting capacity to the power unit's lifting bail.

A. DESIGN

- ⇒ Ride-on design for easy maneuverability on the job.
- ⇒ Designed to meet tight paving specifications.
- ⇒ Hydraulic power for easy operation.
- ⇒ 20 HP gasoline engine.
- ⇒ Rubber coated drive tubes controlled independently of each other for simple alignment corrections.
- ⇒ Crown and camber adjustments that are easily adjusted.
- ⇒ Powder coated paint finish for longer life, professional appearance and easy clean up.

B. FLEXIBILITY

- ⇒ Screed bays from 15 to 50 feet wide using a combination of strike tubes. Comes complete with six tubes (two 18 ft.; two 14 ft.; one 16 ft.; one 8 ft.).
- ⇒ Ideal for handling low slump concrete.

C. QUALITY

- ⇒ Assists in achieving optimum F-numbers using standard finishing techniques.
- ⇒ Produces a floor with excellent surface aggregate consolidation, resulting in a harder, longer wearing surface finish.

D. PRODUCTIVITY

- ⇒ Ride-on design for easy maneuverability on the job. Strikes off over 10,000 square feet per hour.
- ⇒ Instant forward/reverse screeding action. Strikes off concrete more quickly than conventional methods.

WRS-5200 — ASSEMBLY INSTRUCTIONS

A. ROLLER SCREED PARTS ILLUSTRATION

See Figure 2 below for general parts location.

B. PUTTING INTO SERVICE

The purpose of the instructions section of this manual is to explain the intended setup, use and maintenance procedures recommended by Whiteman Industries.

Before packaging and shipment, this Whiteman Ride-on Roller Screed was run and tested at the factory. If there are ANY problems, please contact the Multiquip Service Department.

Make sure that all manuals and instructions are read carefully before putting your new Whiteman Roller Screed into service. Improper setup, use or maintenance of this equipment could result in personnel injury or damage to the equipment. Listed in Figure 2, are the location of main parts described in the next section.

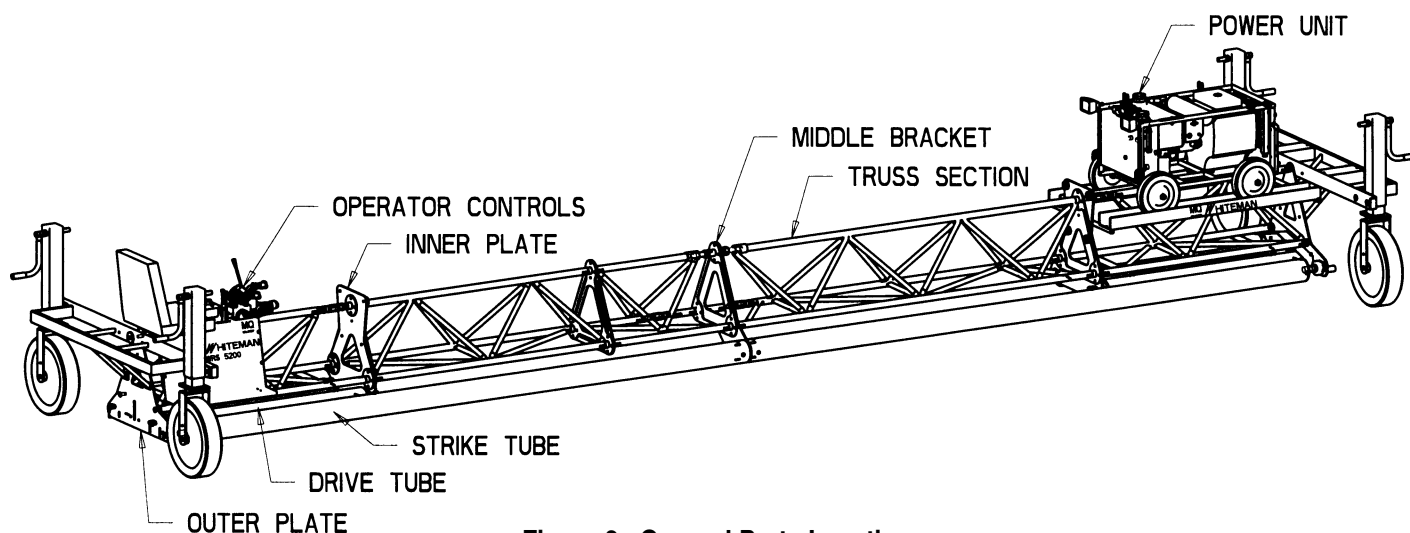

Figure 2. General Parts Location

C. POWER UNIT ASSEMBLY

The power unit comes completely assembled. However, before operating the screed, the hydraulic strike tube motor from the power unit must be bolted to the motor mount, which comes with the screed, as shown in Figure 3. This takes two bolts, 1/2 X 1-1/2.

IMPORTANT: If you change power units, leave the strike tube motor mount with the roller screed for the next power unit.

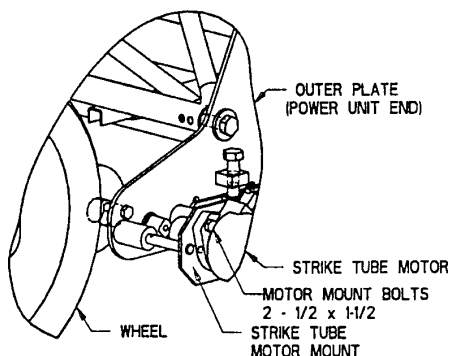

Figure 3. Strike Tube Motor Assembly

Table 2 shows the different combination of truss sections and strike tube lengths to get the desired roller screed length. Dimensions are in feet

Table 2. ROLLER SCREED ASSEMBLY

LENG.(FT)* SECTION	TRUSS SECTION (FT)** STRIKE TUBE(FT)	LETTER CODE ON TRUSS
18	5,8,5 L,RM8,R	18
22	5,9,3,5 L,L14,R8,R	14,8
26	5,4,9,3,5 L,L18,L14,R8,R	18,8
28	5,9,3,6,5 L,L14,R8,R14,R	14,14
30	5,9,8,3,5 L,L14,RM8,R8,R	14,16
32	5,9,3,6,4,5 L,L14,R8,R14,R18,R	14,18
36	5,9,8,3,6,5 L,L14,RM8,R8,R14,R	14,8,14
40	5,9,8,3,6,4,5 L,L14,RM8,R8,R14,R18,R	14,8,18
44	5,9,8,8,3,6,5 L,L14,LM8,RM8,R8,R14,R	14,16,14
44	5,4,9,8,3,6,4,5 L,L18,L14,RM8,R8,R14,R18,R	18,8,18
48	5,9,8,8,3,6,4,5 L,L14,LM8,RM8,R8,R14,R18,R	14,16,18
52	5,4,9,8,8,3,6,4,5 L,L18,L14,LM8,RM8,R8,R14,R18,R	18,16,18

* Actual concrete form width should be at least 2 foot less than screed length.

** Left side of Table 1 in the truss section represents the power unit end

D. ROLLER SCREED ASSEMBLY

2. Description

The WRS 5200 Ride-On Roller Screed is made up of truss sections (Figure 4) which vary in length from 3 to 9 feet. These truss sections support the 6 inch tubing (strike tube) which runs along the front of the machine. This strike tube comes in four different lengths, 8, 14, 16 and 18 feet. By coordinating the truss section and strike tube lengths, various roller screed lengths can be assembled.

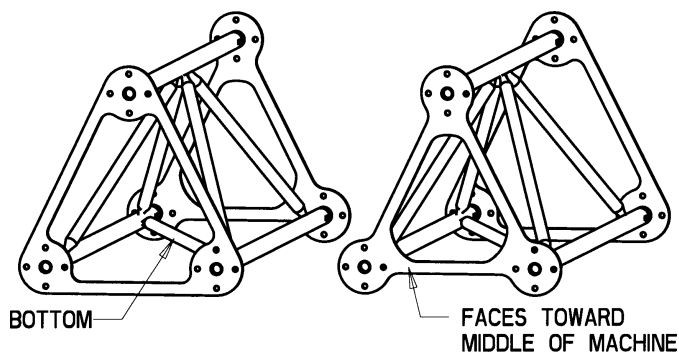

Figure 4. Truss End Plate

WRS-5200 — ASSEMBLY INSTRUCTIONS

It is important in the assembly of the roller screed to keep truss sections on the appropriate side. To help with this, each truss section is stamped with a letter and a number. This stamping is located on the top pipe of each section.

For example, L14, would represent left or the power unit end and combine this section (9 feet) with the end section (5 feet), gives you 14 feet. This is the strike tube length. The stamping on the 9 foot truss section would be L14. Examples of the assembly for different screed lengths are shown in Appendix C.

2. Assembly of the Roller Screed

To begin with, bolt together truss sections that match the length of the strike tubes desired. Find the length of roller screed wanted in the Appendix C and match the strike tubes and truss sections. Use 1-1/2" long bolts where 2 joints come together and 1-3/4" long bolts where 3 joints meet. Don't bolt truss sections from other strike tube lengths together yet.

As an example, the assembly of a 44' roller screed is shown. First check the Appendix C and find the length of screed wanted. Lay the parts as shown in the drawing out in the assembly area. Assemble the truss sections to match the strike tube lengths. For this screed, the strike tube lengths are 14', 16' and 14'.

As an example, the assembly of a 44' roller screed is shown. First check the Appendix C and find the length of screed wanted. Lay the parts as shown in the drawing out in the assembly area. Assemble the truss sections to match the strike tube lengths. For this screed, the strike tube lengths are 14', 16' and 14'. The following Figures, 4, 5 and 6, are the truss sections assembled to match the strike tubes.

Task 1.

Assemble right, left and middle truss sections. See Figures 5, 6, and 7.

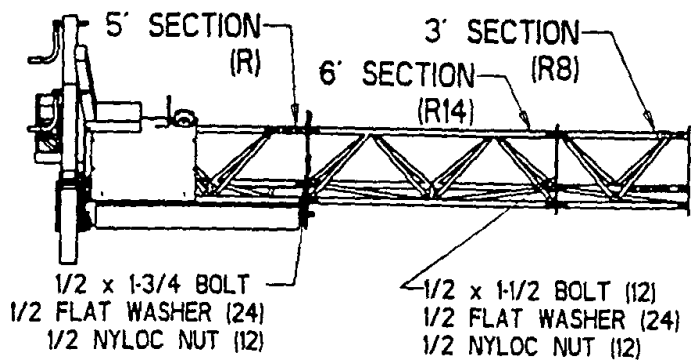

Figure 5. Right Section 14 Feet

WRS-5200 — ASSEMBLY INSTRUCTIONS

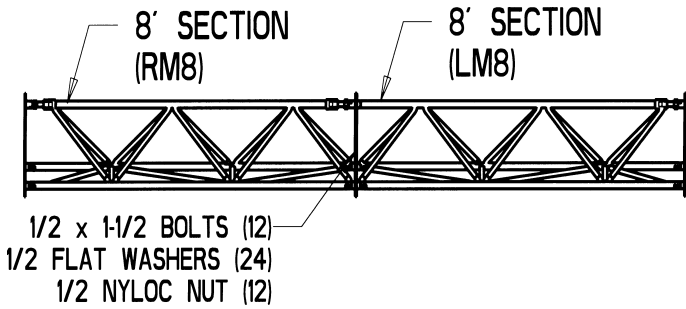

Figure 6. Middle Section 16 Feet

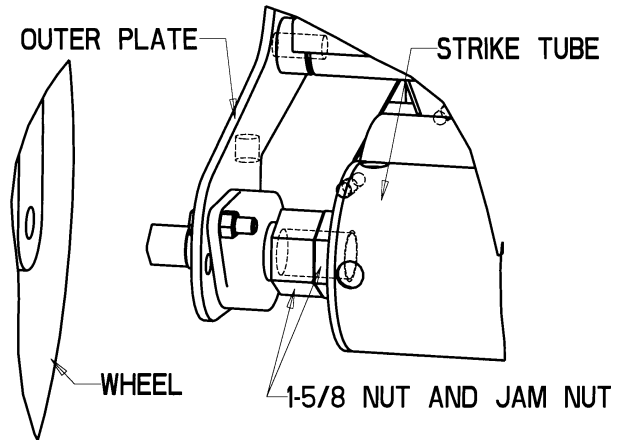

Figure 8. Strike Tube Mount

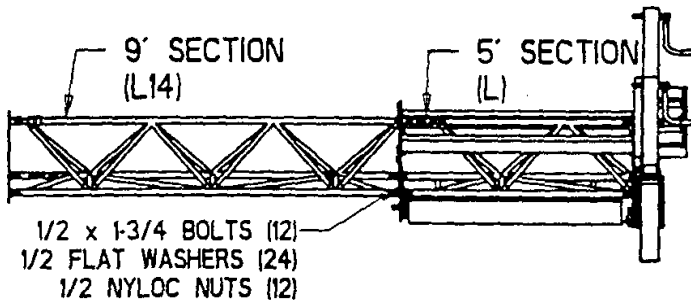

Figure 7. Left Section 14 Feet

Task 2.

Once the assemblies mentioned above are finished, start on one end, take the strike tube and insert it into the 1-3/8 bearing mounted on the outer plate as shown in Figure 8. The 1-5/8 nut and jam nut should be turned in until they are against the strike tube hub.

Task 3.

Take the middle bracket and insert the splined shaft of it into the other end of the strike tube as shown in Figure 9. Slide the middle bracket pins into the section just made.

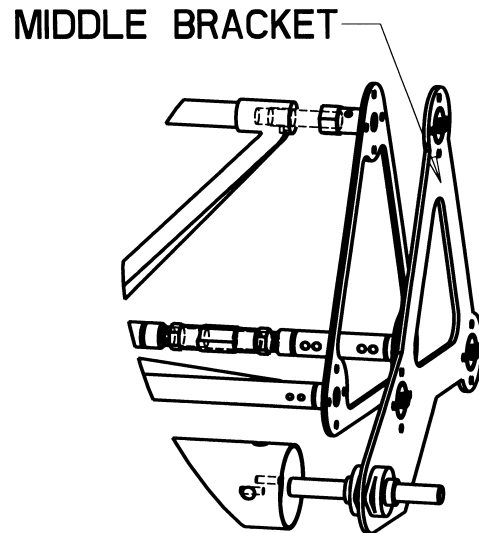

Figure 9. Middle Bracket Mount

Task 4.

If another middle bracket is not required, go to the next paragraph. Two middle brackets are required for three strike tubes, one for two strike tubes. If another middle bracket is required, insert the middle strike tube into the splined shaft of the middle bracket mentioned above. Assemble the truss sections and middle bracket using the $\frac{1}{2}$ X 1-3/4 bolts. Working your way across, take the next middle bracket and insert the splined shaft into the middle strike tube as shown in Figure 9 & 10.

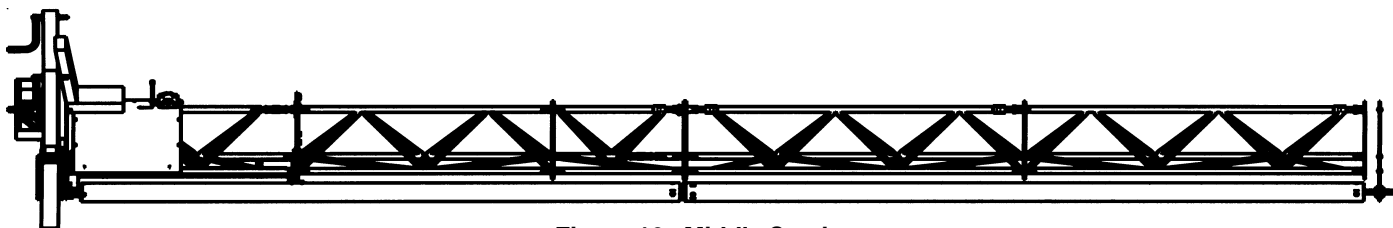

Figure 10. Middle Section

Task 5

Now go to the other end of the roller screed, take the strike tube there and insert it into the second middle bracket's splined shaft. As you pull the last 14' section (Figure 7) into place, insert the end of the strike tube into the bearing as you did in Figure 7. Use $\frac{1}{2}$ x 1-3/4 bolts to bolt the two truss sections and the middle bracket together.

The middle tarp (16') has a place for the truss joint right in the middle.

The left tarp (13'5") has one truss joint located 4 foot in from the end. For this set-up, the 4 foot section will be folded back under the 9 foot.

Task 6.

Once the truss sections are together, string the four long hydraulic hoses through the middle of the trusses. Two male and two female quick connects are required at the other end, one male and female of the 5/8" hose and the same for the $\frac{1}{2}$ " hose.

The buckles on the tarp should be on the back side (strike tube is on front side) and the tarp drain hole on the bottom when finished.

Task 7.

Put the tarps on the appropriate section. The section of the tarp where two nylon straps are close together should fit over a truss joint. All tarps were made to full length per section.

Task 8.

Two more items need to be added on the outside of the tarps. These are the 50 foot electric cord and the pump lever cable. Before buckling the tarp, put the cable and cord behind enough buckles to hold them in place.

The tarp for the right section (13'11") will have two places for the truss joint. It will have a 4 foot section (which for this set-up will be folded back under the next section of tarp) and a 6 and 3 foot section.

Task 9.

Adjust the 1-5/8" nuts on the strike tubes next to the outer plates so the other end of the strike tube next to the middle bracket is spaced from 1/16 to 1/8."

Task 10.

Place the power unit on the appropriate end and the roller screed is ready to use.

D. HANDLING

1. Moving the Machine

WARNING!



DO NOT ATTEMPT TO LIFT THE SCREED FROM THE MIDDLE SECTIONS.

Your Whiteman roller screed was designed to be moved and handled in several ways. Casters that can be lowered are provided to move the machine on and off forms and for moving short distances. When using the casters and moving short distances, the power unit may be left on the roller screed.

If lifting the roller screed is planned for transporting or other reasons, some precautions should be followed.

WARNING!



NEVER TRANSPORT SCREED WITH THE POWER UNIT ON THE MACHINE.

- ⇒ When lifting the roller screed to load for transporting or other purposes, the power unit should be taken off.
- ⇒ Care should be taken to lift the machine correctly. With a fork lift, one end at a time can be lifted onto the transport. Lifting straps should be placed around the top pipe in the 5' end sections. Figure 10 illustrates the recommended lifting points.
- ⇒ Care should These lifting positions are the same for both ends. Attach a lifting strap to one of these points. The safety snap pins in the top turnbuckles of the truss sections are not designed to carry the weight of the machine during lifting. The top of the truss sections should always be kept in compression. Lifting with straps or forks from center sections may damage the machine or bend these pins. Figure 11 shows lifting points A & B. Lifting point "B" can be used with any screed length while lifting point "A" should only be used for screed lengths longer than 32 feet.

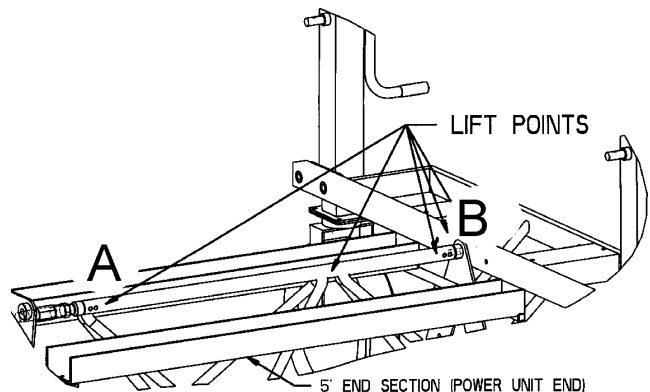

Figure 11. Lifting Points

2. Strike Tube Handling

The strike tubes are a critical component of the roller screed. If the strike tubes are damaged, it is possible they will not turn true. Care should be taken to store extra tubes on a fully supported level surface. Never lift the unit from the strike tubes.

E. Removable Components

The seat section and power unit are removable. Having these pieces removable means you can easily take most of the critical components from the machine with you. This provides a way to better care for your equipment between jobs.

To remove the seat, undo the cord and cable from the power unit and the quick connect hydraulic lines from the stack valve. Windup the cord and cable.

To remove the power unit, attach lifting straps, front-left and back-right and lift with fork lift.

Operators Position)

1. Electric Box (Figure 12).

WARNING!



NEVER DISABLE OR DISCONNECT THE EMERGENCY KILL SWITCH.

Your Whiteman Ride-On Roller Screed is equipped with a safety emergency kill switch. Note: It is provided for operator safety and injury may result if it is disabled, disconnected or improperly maintained.

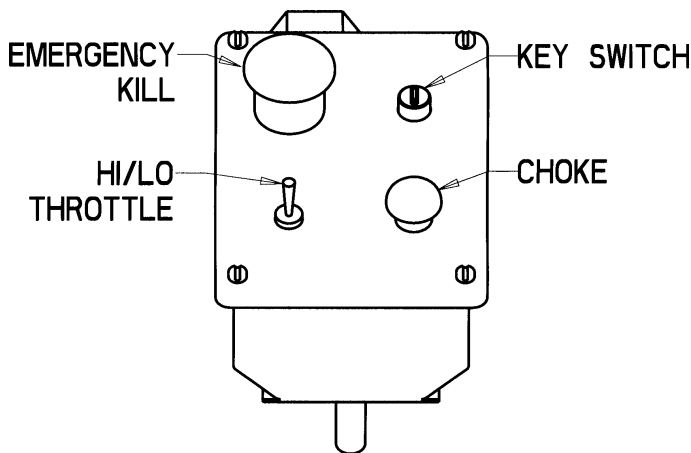

Figure 12. Electric Box

The key switch, shown in Figure 12, is located to the right of the kill switch. The key switch should not work if the kill switch is in the down "Down" position.



THE THROTTLE CONTROL CANNOT BE USED TO STOP THE ENGINE.

WARNING!



THE THROTTLE CONTROL CANNOT BE USED TO STOP THE ENGINE.

Below the kill switch is the "High/Low" toggle switch. This throttle switch has only two positions.

The choke button is to the right of the Hi/Low switch. To activate this switch, you must hold it down.

2. Light Switch.

The light switch is located on the fuse box which is mounted on the radiator end of the power unit.

3. Drive Tube Speed Control Lever (Figure 13).

Located on the far left, above the electric box, this long handle controls the variable speed of the drive tubes. This lever should be in the "Straight Up" position when starting the engine.

4. Drive Tube Direction Control Levers (Figure 13).

Located in the center, these two levers control the direction of travel for the drive tubes. They are independent of each other, so one end can travel forward while the other travels back. Using the levers in this way lets you steer the roller screed.

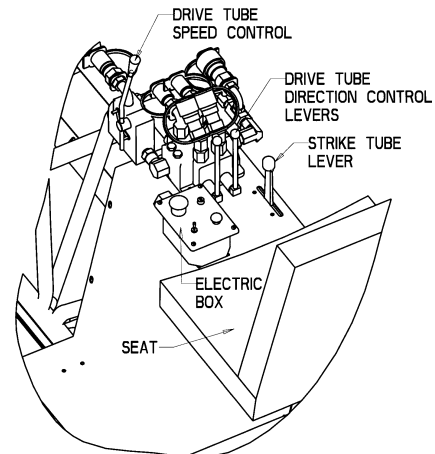

Figure 13. Operator Controls

In order for the drive tubes to move the screed, the “Screed Operation” valve lever on the power unit must be engaged.

5. Strike Tube Control Lever (Figure 13)

On the far right is the strike tube cable control. Pushing the lever to the center is the “Neutral Position”. Shifting the lever either direction determines which way the strike tube turns. The farther you push/pull the lever, the faster the strike tubes turn.

6. Form Specifications

Refer to Appendix B for more information on the recommended type of concrete form to be used.

WRS-5200 — MACHINE START-UP AND OPERATION

A. START-UP

The following steps are intended as a basic guide to machine start-up and operation. Following these procedures will help preserve and maintain the life of this equipment.

- ⇒ Check oil levels in engine and hydraulic reservoir.
- ⇒ Check to make sure there is a full tank of fuel before starting.
- ⇒ On the power unit, put the screed operation valve lever in the “Screed Operation” position.
- ⇒ Put the two drive tube direction control levers shown in Figure 12 in the “Middle” position.
- ⇒ Adjust the drive tube speed control lever shown in Figure 12 to the “Straight Up” position.
- ⇒ Put throttle switch in “Low,” the “Kill Switch” in the “Up” position, and depress the “Choke Switch”, if necessary, while turning the key.
- ⇒ While sitting in the seat, turn the key and start the engine.
- ⇒ Once the engine is warm, put the toggle switch on throttle control to the “High” position to begin operation.

B. CLEANUP

Never allow any concrete to harden on the roller screed.

Immediately after use, wash any concrete off the screed. Be careful not to spray water on the engine while it is still hot.

To operate the pressure washer, attach a garden hose to the pump and turn on the water. Next plug in the quick connect hoses from the pressure washer to the power unit, adjust the three way valve on the power unit as indicated by the decal to the “Pressure Washer” position.

“Clean out” plates for the ends of the center strike tubes (8’ and 16’ tubes) should be removed and the ends cleaned after each use.

Back off the 1-5/8 nut and jam nut on the outside strike tubes next to the outer plate. Slide the strike tube away from the middle bracket and clean the ends.

The solid scraper bars that prevent build-up on the drive tubes should be removed and cleaned as well as the strike tube wipers mounted in front of the 5 foot sections.

WARNING!

PETROLEUM PRODUCTS ARE FLAMMABLE.

Never fill the gas tank while the engine is running or hot. Petroleum products can cause damage to the environment so spills should be cleaned up immediately.

C. MAINTENANCE

Note: See the engine manual supplied with your machine for appropriate engine maintenance schedules and troubleshooting guide for problems.

There is a "Daily Preparation Checklist" in the front section of this manual. Please feel free to make copies of it and use it on a daily basis.

WARNING!



DISCONNECT BATTERY CABLES AND SPARK PLUG WIRES BEFORE ATTEMPTING ANY SERVICE OR MAINTENANCE ON THIS MACHINE.

D. MAINTENANCE SCHEDULE

Daily (8-10 Hours)

⇒ Check the fluid levels in the engine and hydraulic reserve, fill as necessary.

⇒ Lubricate all grease zerks after cleaning the machine while the chain guards are off, including bearings on the middle brackets which hold the splined shafts.

Weekly (30-40 Hours)

⇒ Check and clean or replace the engine air filter as necessary.

⇒ Replace the engine oil and filter as necessary, see engine manual.

⇒ Check bolts for tightness on truss sections.

Monthly (100-125 Hours)

⇒ Check air pressure in tires.

Yearly (500-600 Hours)

⇒ Replace hydraulic fluid and filters.

⇒ Check set screws on the middle bracket bearings which hold the splined shaft in place. If loose, add some liquid locking agent to the set screws and re-tighten. A "stop" inside the strike tube prevents the splined shafts from ever moving too far.

⇒ Note: After the first 100 hours, replace the hydraulic filter cartridges.

WRS-5200 — MAINTENANCE AND ADJUSTMENT PROCEDURES

WARNING!



DO NOT AT ANY TIME MAKE ADJUSTMENTS TO THE ROLLER SCREED WITHOUT STOPPING THE ENGINE AND DISCONNECTING THE SPARK PLUG WIRE.

A. ADJUSTING STRIKE TUBE HEIGHT

Strike tube height is adjusted by raising or lowering the height of the drive tubes. Figure 14 illustrates this. The chain idler will also need adjusting in the same direction of travel as the drive tubes. Loosen the two bolts which hold each drive tube bearing and adjust the $\frac{3}{4}$ " bolt to desired height. Tighten the bearing bolts and chain idler adjustment when finished. Adjust the strike tube so it is just clearing the concrete form.

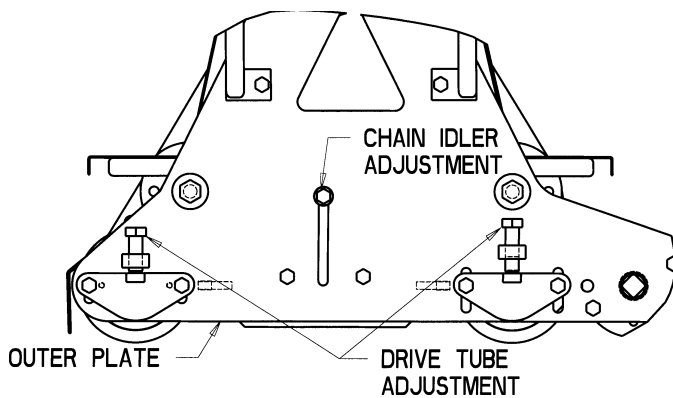

Figure 14. Strike Tube Adjustment

B. CROWN ADJUSTMENT

To adjust the crown, pull the $\frac{3}{8}$ " safety snap pin and adjust the screw with the wrench provided. Shown in Figure 15.

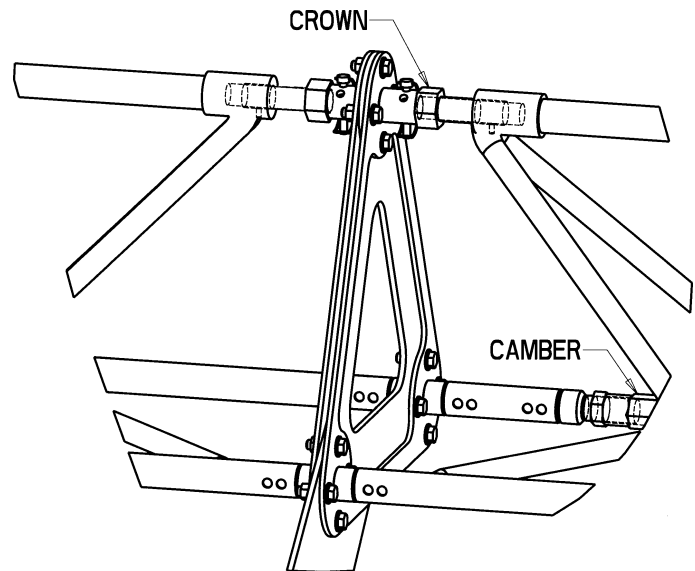

Figure 15. Crown and Camber Adjustment

C. CAMBER ADJUSTMENT

To modify the camber in the screed, adjust the turnbuckle which is shown in Figure 15. Loosen the two jam nuts and adjust the screw with the wrenches provided. A plum line stretched along the front of the machine will help to adjust straightness to.

D. STRAIGHTNESS OF STRIKE TUBES

Should strike tubes begin turning unevenly, contact your local Multiquip representative for information on strike tube straightening procedures.

To determine if a strike tube is turning uneven, place a 2 x 4 stud on the ground in the center of the strike tube as it sits on the machine. Slide it close to the strike tube. Take the strike tube motor off the end. Spin the strike tube by hand. If a gap of over 1/8 inch shows up, contact your representative.

E. AUXILIARY HUB

An auxiliary hub, shown in Figure 16, for use with different strike tubes is provided. Using the hub provides additional combinations of roller screed lengths. Two 1/2 x 2-1/4 bolts are provided for the purpose of bolting the hub to the strike tube end.

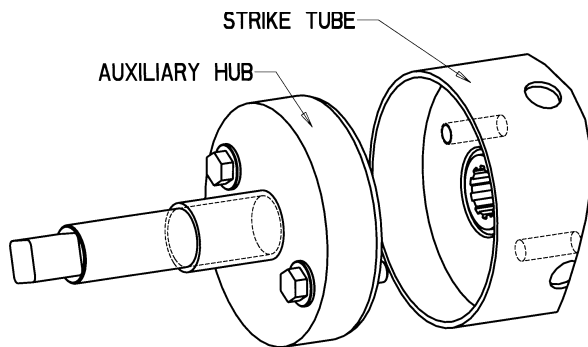

Figure 16. Auxiliary Hub

F. CHANGING THE HYDRAULIC FILTER

Usually the hydraulic filter and oil will be changed at the same time. If not, creating a back suction on the hydraulic tank will stop the flow of hydraulic oil when changing the filters.

G. SCRAPER AND WIPER BAR ADJUSTMENT

Scraper bars should be adjusted to approximately 1/8" distance from the drive tubes.

Wiper bars should be adjusted to approximately 1/8" distance from the strike tube. The turnbuckle in the top pipe of the 5' section is also an adjustment for the wiper bar. This adjustment can be used when the end of the wiper bar is too close to the strike tube. **IMPORTANT:** Never let anything rub grooves into the strike tube(i.e. wiper bars, concrete forms, bolts, etc.) because those grooves in the strike tube will be transferred into the concrete.

H. STRIKE TUBE ADJUSTMENT NUT

The strike tube adjustment nut, shown in Figure 8, should be adjusted so the inner edge of the strike tube next to the middle bracket is spaced at about 1/16 to 1/8". Note: The strike tube will bottom out on the splined shaft when 1/16" is left and further adjustment will bend the outer plate.

I. SPLINED SHAFT SET SCREWS

Each roller screed comes with two middle brackets as shown in Figure 9. Bearings mounted on the middle bracket hold the splined shaft. The set screws in the bearings should be checked for tightness occasionally.

J. REVERSING END CASTER BRACKETS

Figure 17 illustrates how end caster brackets can be reversed. This allows the roller screed to fit into areas close to walls and columns.

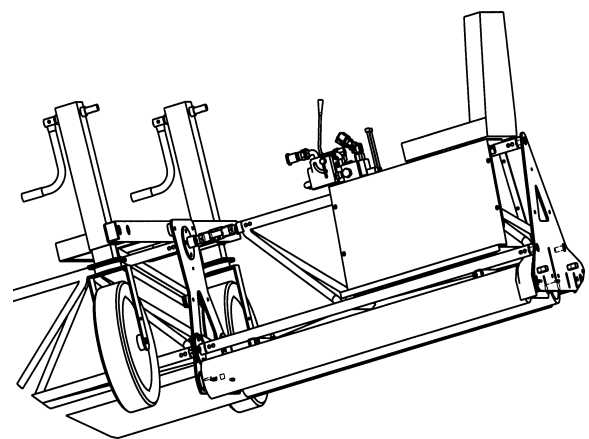

Figure 17. Reversing Caster Brackets

WARNING!

READ THE INSTRUCTION MANUAL COMPLETELY BEFORE ATTEMPTING MACHINE OPERATION!



The following steps are intended as a basic guide to help in the operation of this equipment.

A. FAMILIARIZATION WITH EQUIPMENT

Take a walk around the machine. Take notice of all the major components on the machine like the control handles, the engine, the strike tubes and the truss sections. Look at the machine construction. Check the fuel and hydraulic system. Look at the engine and find the oil dipstick. Check the oil levels in the engine and hydraulic tank. Make sure the machine has fuel enough for the planned operation.

While seated in the operator's position, note the locations of the controls. On the left is the electric box with four switches which were described in the startup section of this manual. Just above the electric box on the left is the speed control lever for the drive tubes.

In the center are the levers of the stack valve which operate the drive tubes forward and reverse on both ends and finally on the right side is the lever for running the strike tubes. The speed of the strike tubes depends on the how far you push/pull the lever. The cable from this lever is attached to the hydraulic pump lever on the power unit.

B. FIRST MACHINE OPERATION

Now, following the startup procedure found in the "Machine Start-up and Operation" section of this manual, start the engine and let it warm up. Remember that when warming up an engine, let the engine idle. When the engine is warm, test the kill switch. The engine should die and the key should not crank the engine with the emergency kill switch down.

Restart the engine. Before operating the roller screed, check for people around the machine. As a suggestion, imagine a rectangle that envelopes the entire machine. Never let anyone into that rectangle while you are operating the machine. Always be aware of your surroundings.

Practice running the roller screed in a straight line. As you become comfortable maneuvering the roller screed, try turning off one side of the drive tubes and then the other. This adjusts how parallel the screed moves with the forms, and also allows you to steer around the columns.

C. CONCEPTS FOR USE OF ROLLER SCREED

The purpose of the roller screed is to strike off the surface of the concrete at a predetermined grade. The quality of screeding has a big effect on floor levelness and flatness.

This machine was designed to be able to go back and forth on the forms, working the concrete to the desired grade. The strike tube rotation should always push the concrete forward into the areas that don't have concrete yet.

Depending on the slump of the concrete, several passes might be required for the right strike off grade. On the last pass over the concrete, rotate the strike tube in the opposite direction and go slowly forward. This leaves a thin layer which can be easily bull floated.

WRS-5200 — SUGGESTED TRAINING

A pressure washer is available as an option with this machine. Figure 18 shows the components that come with this option. This is a hydraulic-motor driven pump pressure washer which is connected to the power unit with quick connect fittings. The pressure washer runs at 1500 psi and comes complete with a 50 foot pressure wash hose, trigger gun with insulated wand and a turbo nozzle.

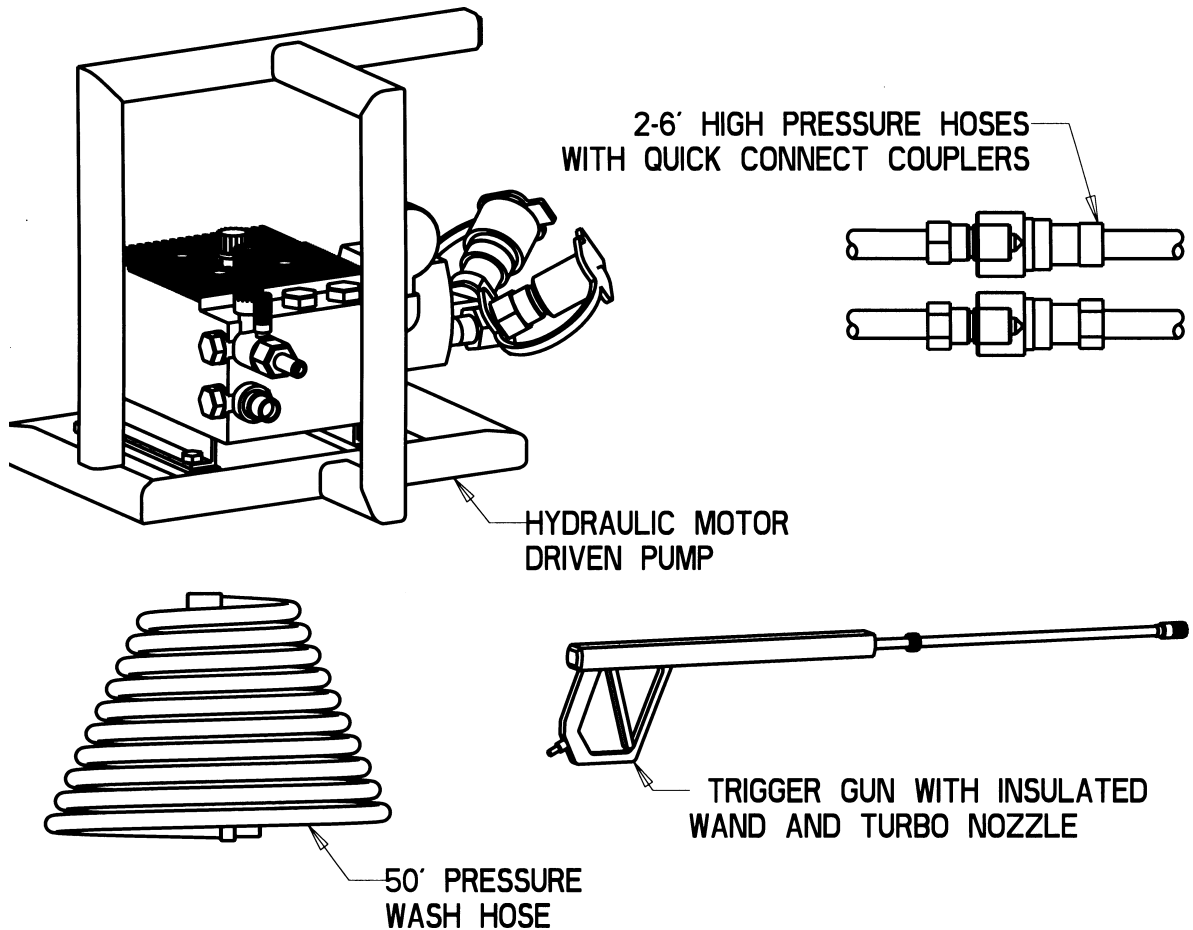

Figure 18. Pressure Washer

The Whiteman WRS-5200 roller screed provides all of the benefits of labor savings, high productivity and enhanced floor flatness/levelness qualities. To order to maximize these benefits, care must be taken to insure a successful application. Inadequate substrate and form support can lead to form failure causing unnecessary job delays, and expenses while contributing to poor floor flatness and floor levelness ratings. The intent of these specifications is to establish minimum guidelines to help the contractor choose the most economical and effective form work/support system to fit any job site needs.

It is recommended that at least the day prior to the concrete pour, a dry run be accomplished to test the load capacity of the forms and substrate. Proper job planning is essential to a successful application.

The WRS-5200 weighs approximately 4000 lbs (at 52 feet of screed) approx. 2000 lbs. per side. Any screed support (forms, rails, rail supports and substrate) must withstand 2000 lb. "point load" at a 2:1 safety factor.

SUBGRADE/DECK FORMS-

Subgrade must be sound enough to support slab edge forms and bracing as well as the load imposed by the screed and its supports. Potential deflection, as in the case with metal and plywood decks, should be considered when determining brace and support spacing. Soil subgrades must be well compacted and must be able to support bearing pressures greater than or equal to those imposed by the screed supports and the slab forming. For proper bearing support, shims should be used to adequately distribute loads where grade is not level or is soft. Use standard ACI concrete form pressures when calculating lateral loads on slab edge forms

WOOD FORMS-

Wood forms are **NOT** a preferred method of screed support. Because of the concentrated bearing loads by the screed, wood is not a good support material. Nominal 2x (1-1/2" No.2 Douglas fir is calculated to support a maximum of 1000 lb. The grain could crush and splinter causing level variations and potential failure. 4x (3-1/2") lumber for edge form should be acceptable.

SCREED RAILS AND SUPPORT-

Screed rails (Figure 19) and supports, independent of slab edge forming are a preferred method. Due to strength, deflection and traction considerations, 2.5" x 2.5" x 875 (3/16") wall structural steel tubing with adjustable supports spaced as shown in the attached drawings. Standard deflection with a 3/16" wall thickness for the above configuration is 1/6" in 4 ft. Refer to standard material charts for other configurations.

STEEL FORMS-

Paving forms with 90° lip-edge at bottom with stake pockets is preferred. If soft or unlevelled subgrade is encountered, a 2x bearing pad and/or shims should be used under the steel forms for additional bearing support. Depending on slab thickness and subgrade, forms may require diagonal bracing.

These specifications are provided as a service to illustrate the application of MQ - WHITEMAN products only and are not intended to be fully directive or cover all engineering details, MQ - WHITEMAN will not be responsible for the improper application of its products.

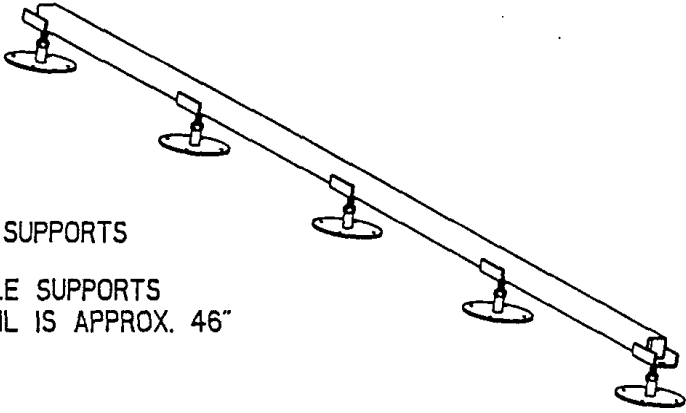
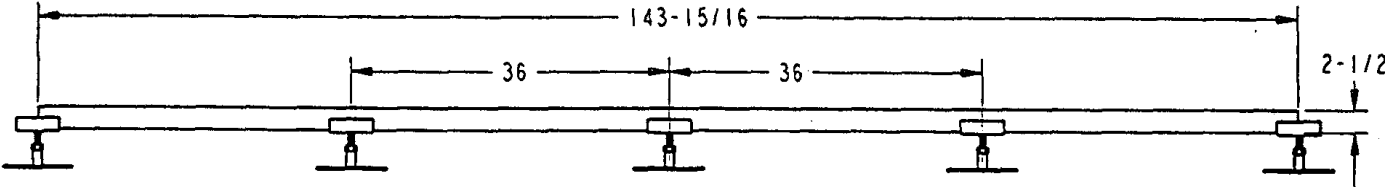

SCREED RAILS AND SADDLE SUPPORTS
MAXIMUM SPACING OF SADDLE SUPPORTS
FOR 1/16" DEFLECTION IN RAIL IS APPROX. 46"

Figure 19. Screed Rails

WRS-5200 — 18 AND 22 FOOT SCREED LENGTHS

1	1	TUBE, STRIKE 18'
2	1	FRAME, 8' (RM8)
3	1	HUB, AUX. (BOLT ON)
4	1	FRAME, 5' OPERATOR END
5	1	FRAME, 5' POWER UNIT END

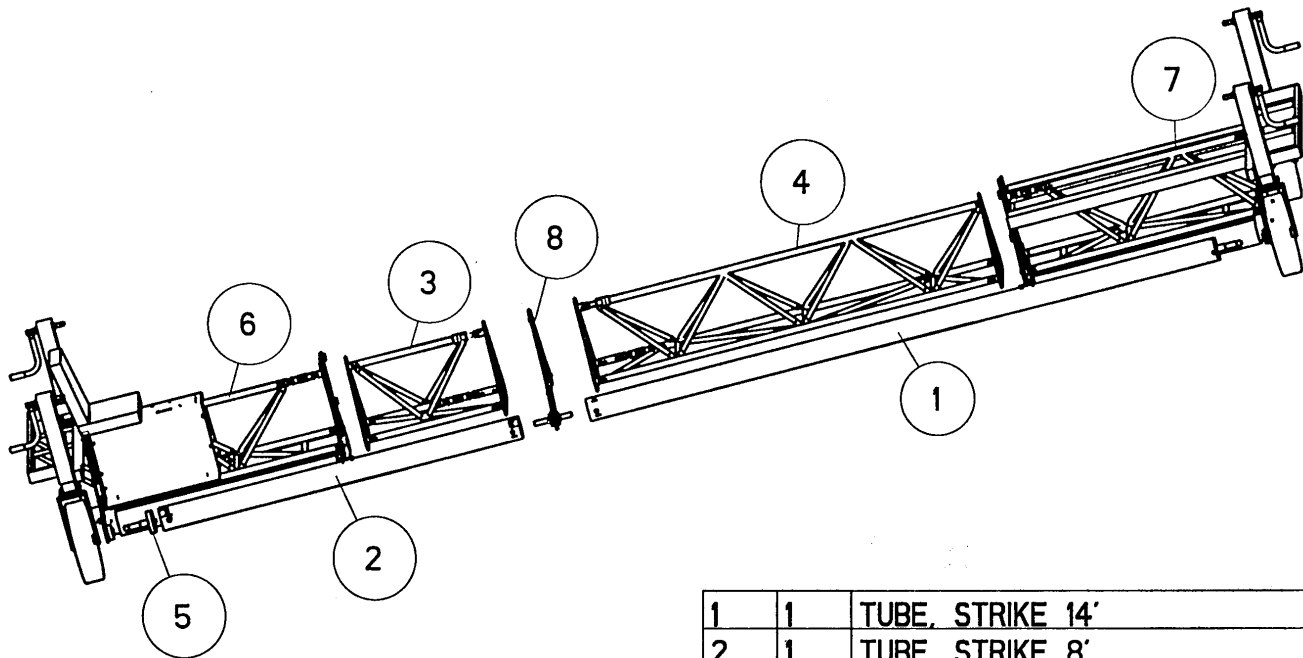
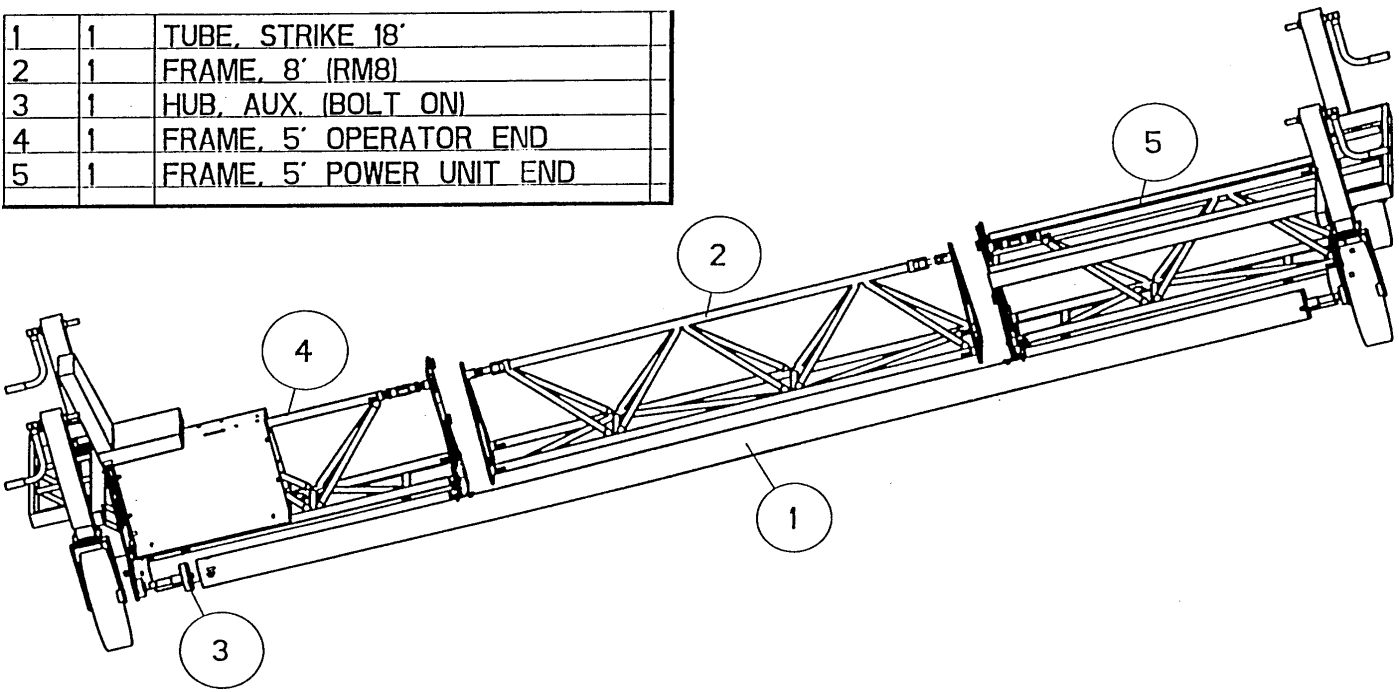

1	1	TUBE, STRIKE 14'
2	1	TUBE, STRIKE 8'
3	1	FRAME, 3' (R8)
4	1	FRAME, 9' (L14)
5	1	HUB, AUX. (BOLT ON)
6	1	FRAME, 5' OPERATOR END
7	1	FRAME, 5' POWER UNIT END
8	1	BRACKET, MIDDLE

WRS-5200 — 26 AND 28 FOOT SCREED LENGTHS

1	1	TUBE, STRIKE 18'
2	1	TUBE, STRIKE 8'
3	1	FRAME, 3' (R8)
4	1	FRAME, 4' (L&R18)
5	1	FRAME, 9' (L14)
6	1	HUB, AUX. (BOLT ON)
7	1	FRAME, 5' OPERATOR END
8	1	FRAME, 5' POWER UNIT END
9	1	BRACKET, MIDDLE

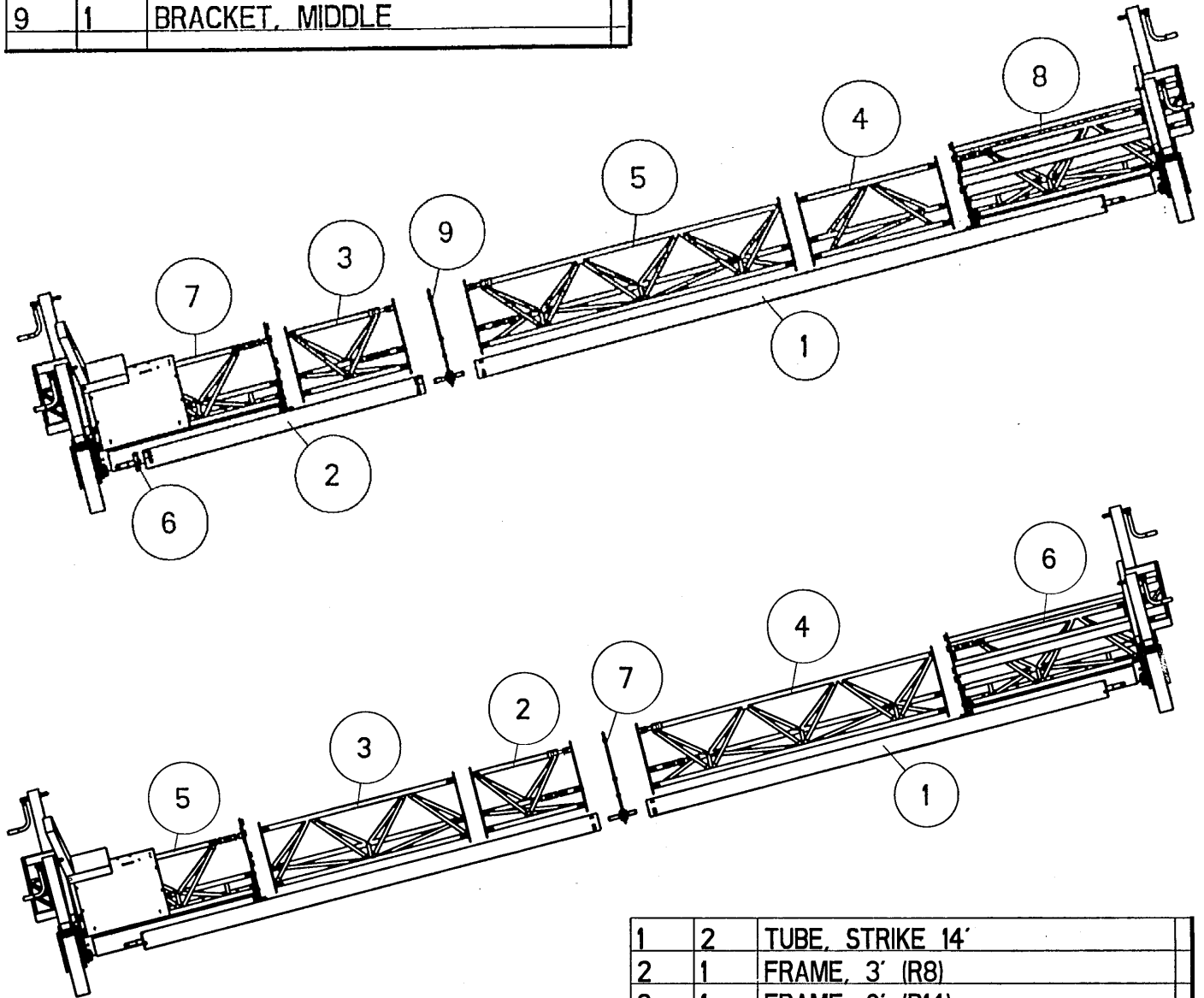

1	2	TUBE, STRIKE 14'
2	1	FRAME, 3' (R8)
3	1	FRAME, 6' (R14)
4	1	FRAME, 9' (L14)
5	1	FRAME, 5' OPERATOR END
6	1	FRAME, 5' POWER UNIT END
7	1	BRACKET, MIDDLE

WRS-5200 — 30 AND 32 FOOT SCREED LENGTHS

1	1	TUBE, STRIKE 14'
2	1	TUBE, STRIKE 16'
3	1	FRAME, 3' (R8)
4	1	FRAME, 8' (LM8)
5	1	FRAME, 9' (L14)
6	1	HUB, AUX. (BOLT ON)
7	1	FRAME, 5' OPERATOR END
8	1	FRAME, 5' POWER UNIT END
9	1	BRACKET, MIDDLE

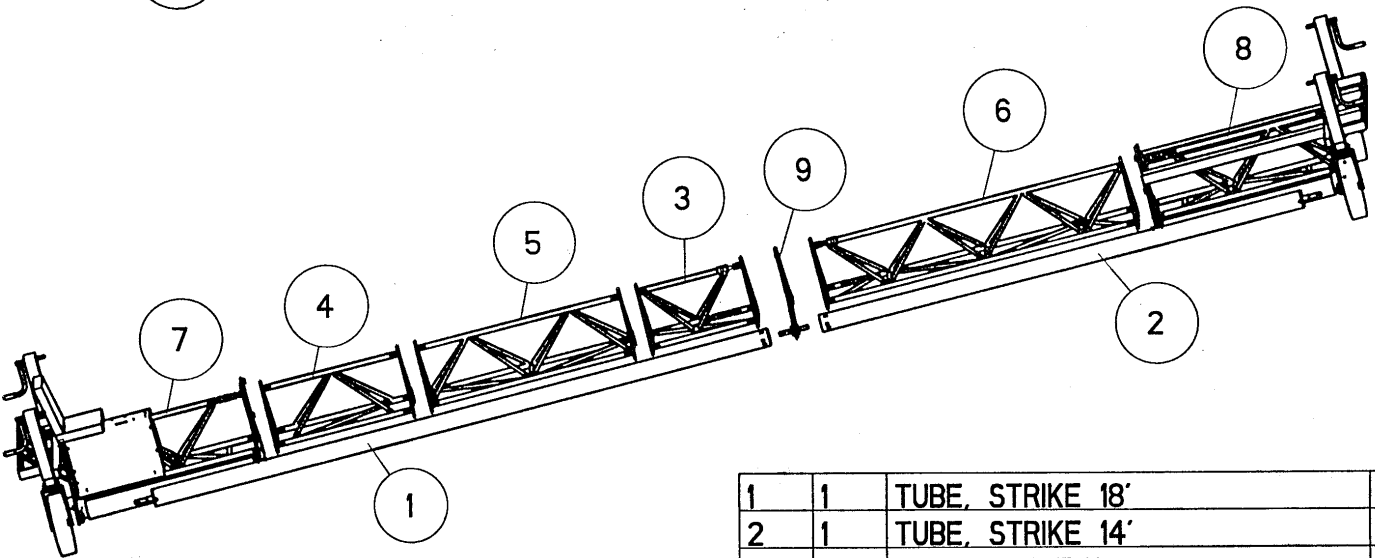
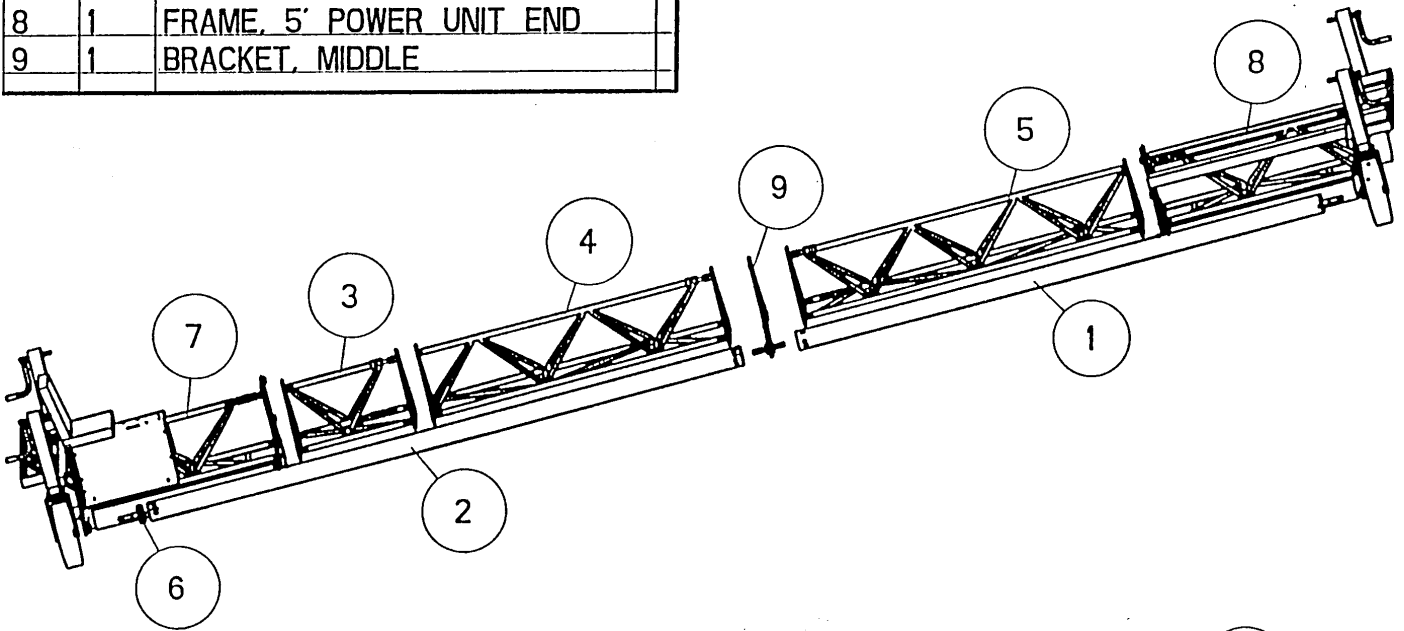

1	1	TUBE, STRIKE 18'
2	1	TUBE, STRIKE 14'
3	1	FRAME, 3' (R8)
4	1	FRAME, 4' (L&R18)
5	1	FRAME, 6' (R14)
6	1	FRAME, 9' (L14)
7	1	FRAME, 5' OPERATOR END
8	1	FRAME, 5' POWER UNIT END
9	1	BRACKET, MIDDLE

WRS-5200 — 36 AND 40 FOOT SCREED LENGTHS

1	2	TUBE, STRIKE 14'
2	1	TUBE, STRIKE 8'
3	1	FRAME, 3' (R8)
4	1	FRAME, 6' (R14)
5	1	FRAME, 8' (RM8)
6	1	FRAME, 9' (L14)
7	1	FRAME, 5' OPERATOR END
8	1	FRAME, 5' POWER UNIT END
9	2	BRACKET, MIDDLE

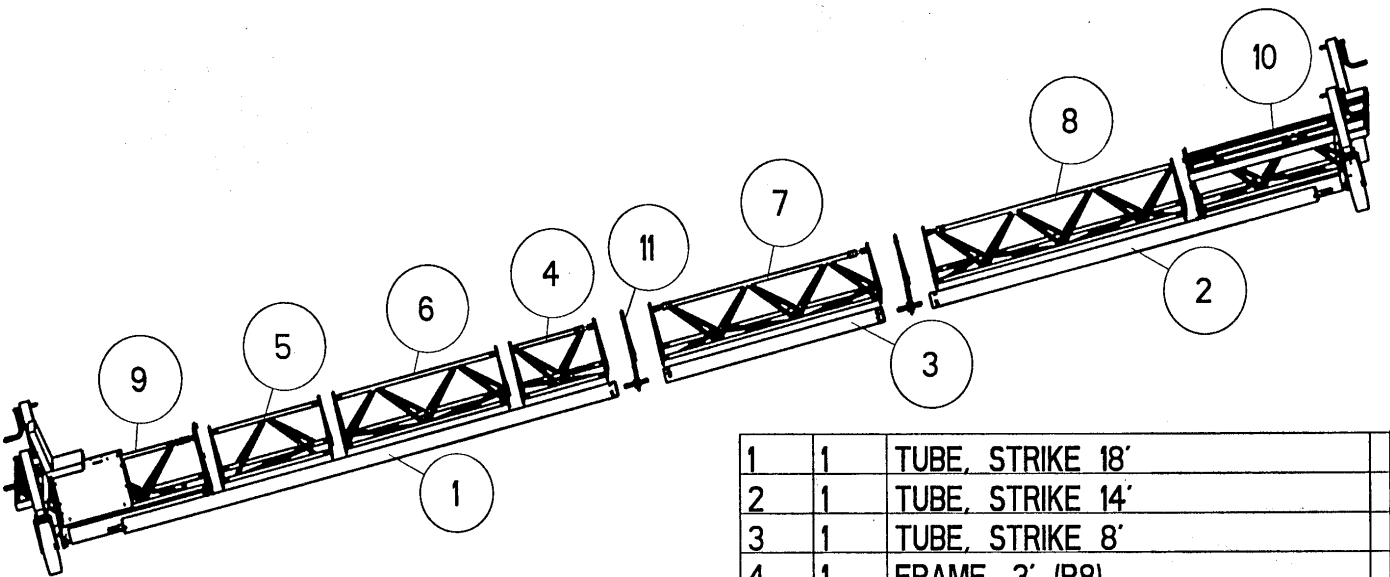
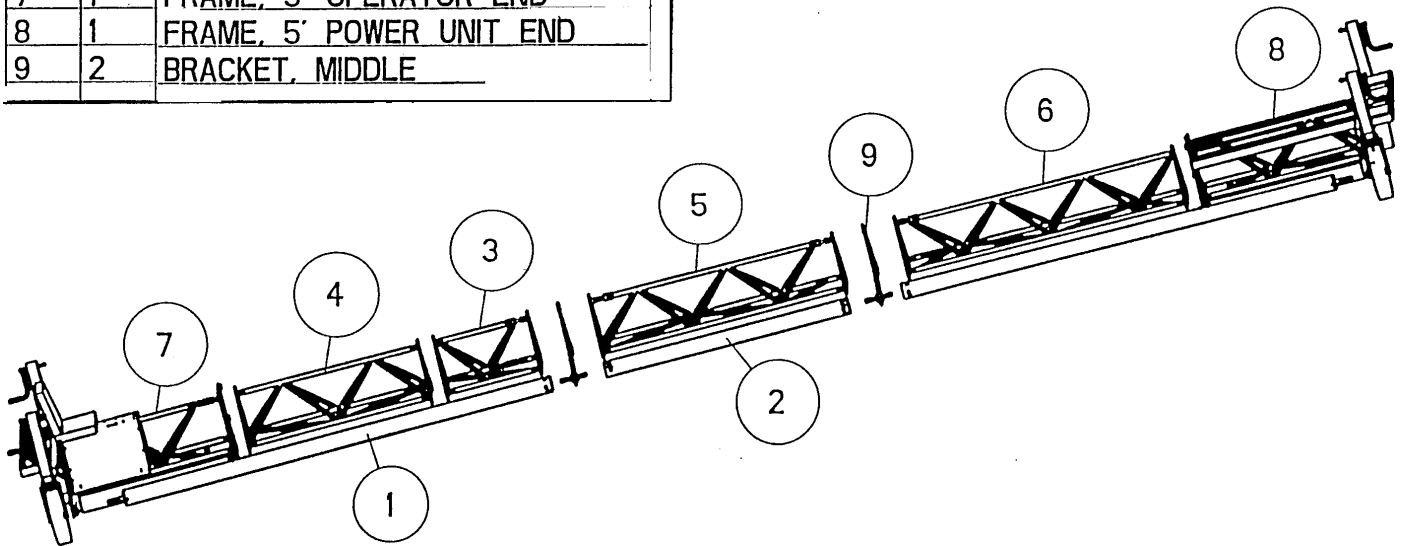

1	1	TUBE, STRIKE 18'
2	1	TUBE, STRIKE 14'
3	1	TUBE, STRIKE 8'
4	1	FRAME, 3' (R8)
5	1	FRAME, 4' (L&R18)
6	1	FRAME, 6' (R14)
7	1	FRAME, 8' (RM8)
8	1	FRAME, 9' (L14)
9	1	FRAME, 5' OPERATOR END
10	1	FRAME, 5' POWER UNIT END
11	2	BRACKET, MIDDLE

WRS-5200 — 44 FOOT SCREED LENGTHS

1	2	TUBE, STRIKE 14'
2	1	TUBE, STRIKE 16'
3	1	FRAME, 3' (R8)
4	1	FRAME, 6' (R14)
5	1	FRAME, 8' (RM8)
6	1	FRAME, 8' (LM8)
7	1	FRAME, 9' (L14)
8	1	FRAME, 5' OPERATOR END
9	1	FRAME, 5' POWER UNIT END
10	2	BRACKET, MIDDLE

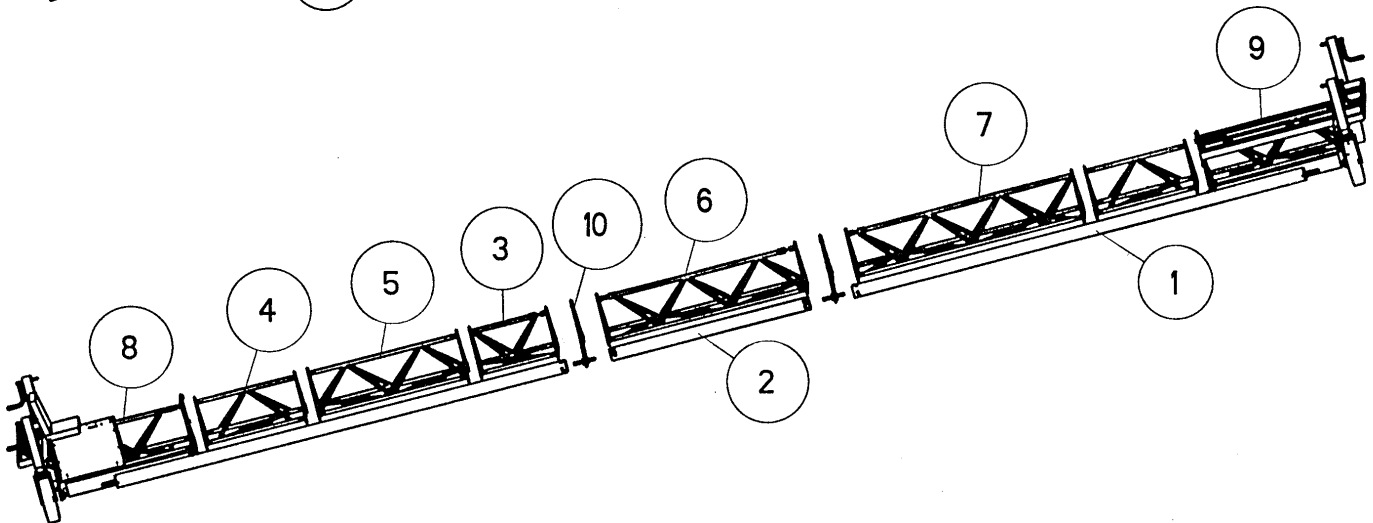
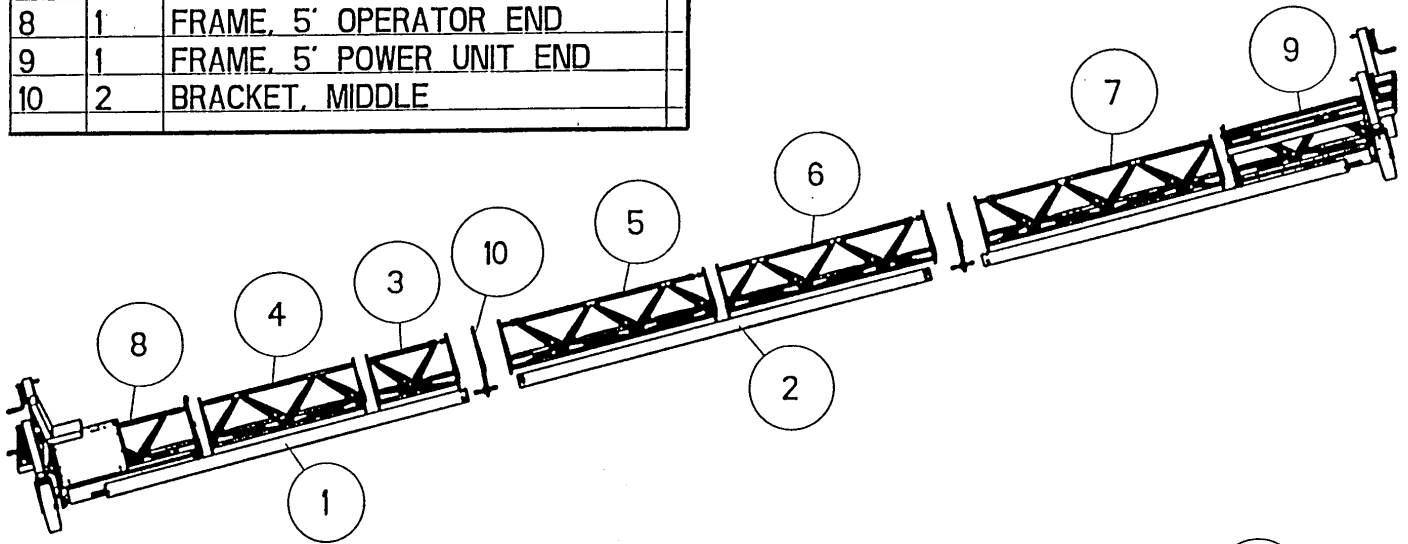

1	2	TUBE, STRIKE 18'
2	1	TUBE, STRIKE 8'
3	1	FRAME, 3' (R8)
4	2	FRAME, 4' (L&R18)
5	1	FRAME, 6' (R14)
6	1	FRAME, 8' (RM8)
7	1	FRAME, 9' (L14)
8	1	FRAME, 5' OPERATOR END
9	1	FRAME, 5' POWER UNIT END
10	2	BRACKET, MIDDLE

WRS-5200 — 48 AND 52 FOOT SCREED LENGTHS

1	1	TUBE, STRIKE 18'
2	1	TUBE, STRIKE 14'
3	1	TUBE, STRIKE 16'
4	1	FRAME, 3' (R8)
5	1	FRAME, 4' (L&R18)
6	1	FRAME, 6' (R14)
7	1	FRAME, 8' (RM8)
8	1	FRAME, 8' (LM8)
9	1	FRAME, 9' (L14)
10	1	FRAME, 5' OPERATOR END
11	1	FRAME, 5' POWER UNIT END
12	2	BRACKET, MIDDLE

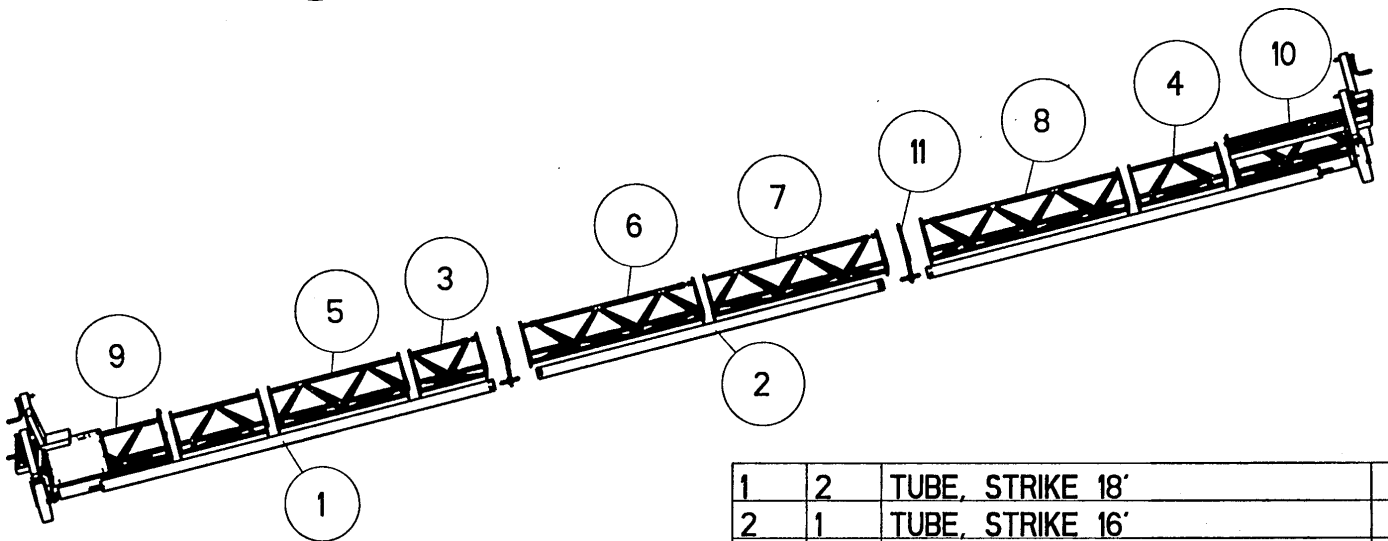
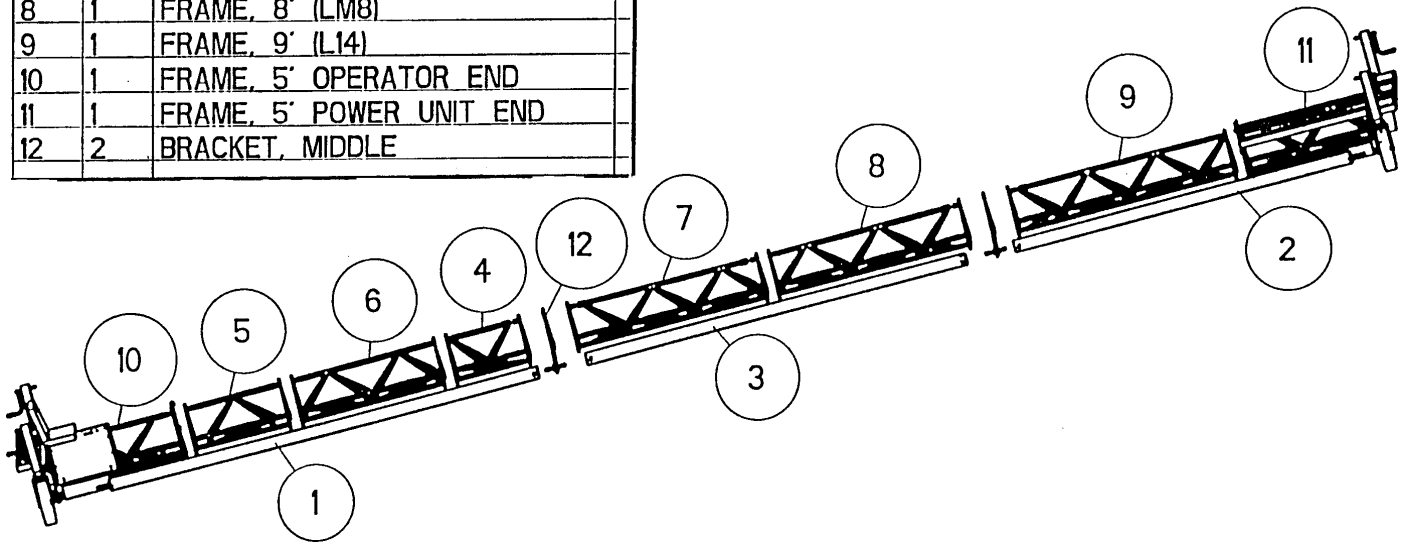

1	2	TUBE, STRIKE 18'
2	1	TUBE, STRIKE 16'
3	1	FRAME, 3' (R8)
4	2	FRAME, 4' (L&R18)
5	1	FRAME, 6' (R14)
6	1	FRAME, 8' (RM8)
7	1	FRAME, 8' (LM8)
8	1	FRAME, 9' (L14)
9	1	FRAME, 5' OPERATOR END
10	1	FRAME, 5' POWER UNIT END
11	2	BRACKET, MIDDLE

WRS-5200 — FRAME ASSEMBLY (OPERATOR END)

FRAME ASSEMBLY (OPERATOR END)

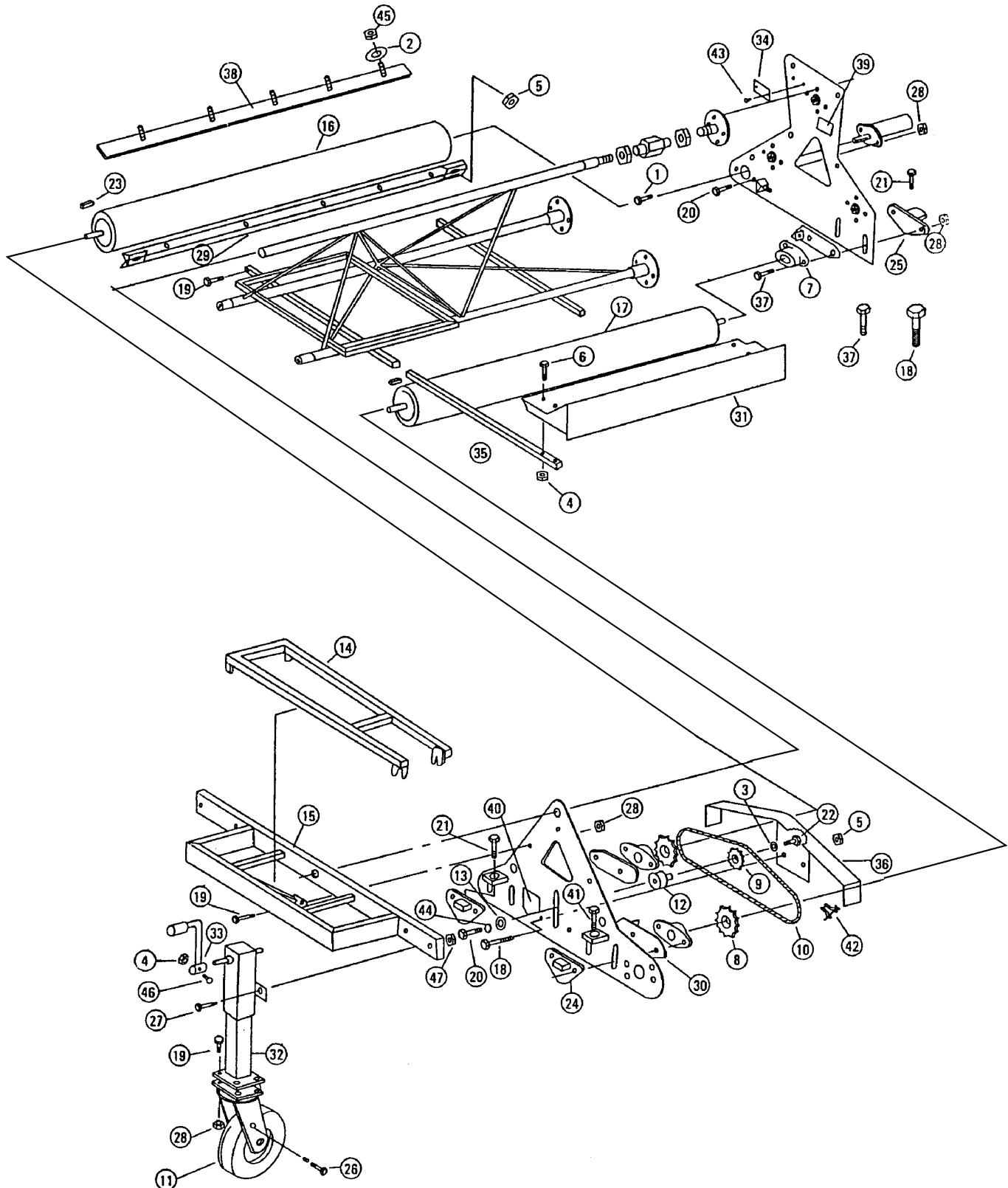

WRS-5200 — FRAME ASSEMBLY (OPERATOR END)

FRAME ASSEMBLY (OPERATOR END)

<u>NO</u>	<u>PART NO</u>	<u>PART NAME</u>	<u>QTY.</u>	<u>REMARKS</u>
1	0166	Screw, HHC 3/8-16 x 7/8	1	
2	0300 B	Washer, Flat, 7/16 SAE	10	
3	0448	Washer, Flat, 7/16 SAE	1	
4	10133	Nut, Nyloc 3/8-16	6	
5	10176	Nut, Nyloc 1/2-13	6	
6	1284	Screw, HHC 3/8-16 x 1-1/2	4	
7	16223	Bearing, 1-3/8	3	
8	16225	Sprocket	2	
9	16226	Sprocket, Idler	1	
10	16227	Chain, Roller	1	
11	16231	Caster, (includes wheels and bracket)	2	
12	16303	Mount, Idler Sprocket	1	
13	16372	Spacer, 1/4	1	
14	16378	Pull Handle W/A	1	
15	16469	Bracket, Caster W/A OPER End	1	
16	16492	Tube, Drive Rear W/A	1	
17	16493	Tube, Drive Front W/A	1	
18	16521	Screw, HHCS 1/2-13 x 4 GD 8	4	
19	16524	Screw, HHCS 1/2-13 x 1-1/4 GD 8	12	
20	16525	Screw, HHCS 1/2-13 x 1-1/2 GD 8	3	
21	16529	Screw, HHCS 3/4-10 x 2 GD 8	3	
22	16530	Screw, HHC 7/16-14 x 1	1	
23	16533	Key, 5/16 x 5/16 x 7/8	2	
24	16538	Bearing Adjustment W/A Short	2	
25	16539	Bearing Adjustment W/A Long	1	
26	16627	Bolt, Shoulder 5/8 x 3/4 PLTD	4	
27	16628	Bolt, Shoulder 3/4 x 2-1/4 PLT	4	
28	16629	Nut, Nyloc 1/2-13 GD 8	18	
29	16658	Wiper, Solid W/A	2	
30	16659	Mount, Solid Wiper W/A	3	
31	16681	Mount, Wiper Right	1	
32	16683	Jack, Screed W/A	2	
33	16685	Handle, Jack W/A	2	
34	16689	Name Plate, Screed	1	
35	16695	Arm, Wiper W/A	2	
36	16703	Guard, Chain W/A Control End	1	
37	16781	Screw, HHCS 1/2 - 13 x 2. 1/4 GD 8	8	
38	16868	Bar, Scraper W/A	2	
39	16880	Decal, Lifting Warning	1	
40	16883	Decal, Chain Drive Warning	1	
41	16890	Screw, HHC 3/4 x 2-1/2 GD 5	1	
42	16927	Chain, Roller Offset	1	
43	4014	Screw, 2-3/16 P-K Type U Drive	2	
44	5054 A	Washer, Lock, 1/2 Medium	1	
45	5283	Nut, Nyloc 5/16-18	10	
46	9154	Screw, HHC 3/8-16 x 1-3/4	2	
47	9503	Nut, Nyloc 5/8-11	4	

WRS-5200 — FRAME ASSEMBLY (ENGINE END)

FRAME ASSEMBLY (ENGINE END)

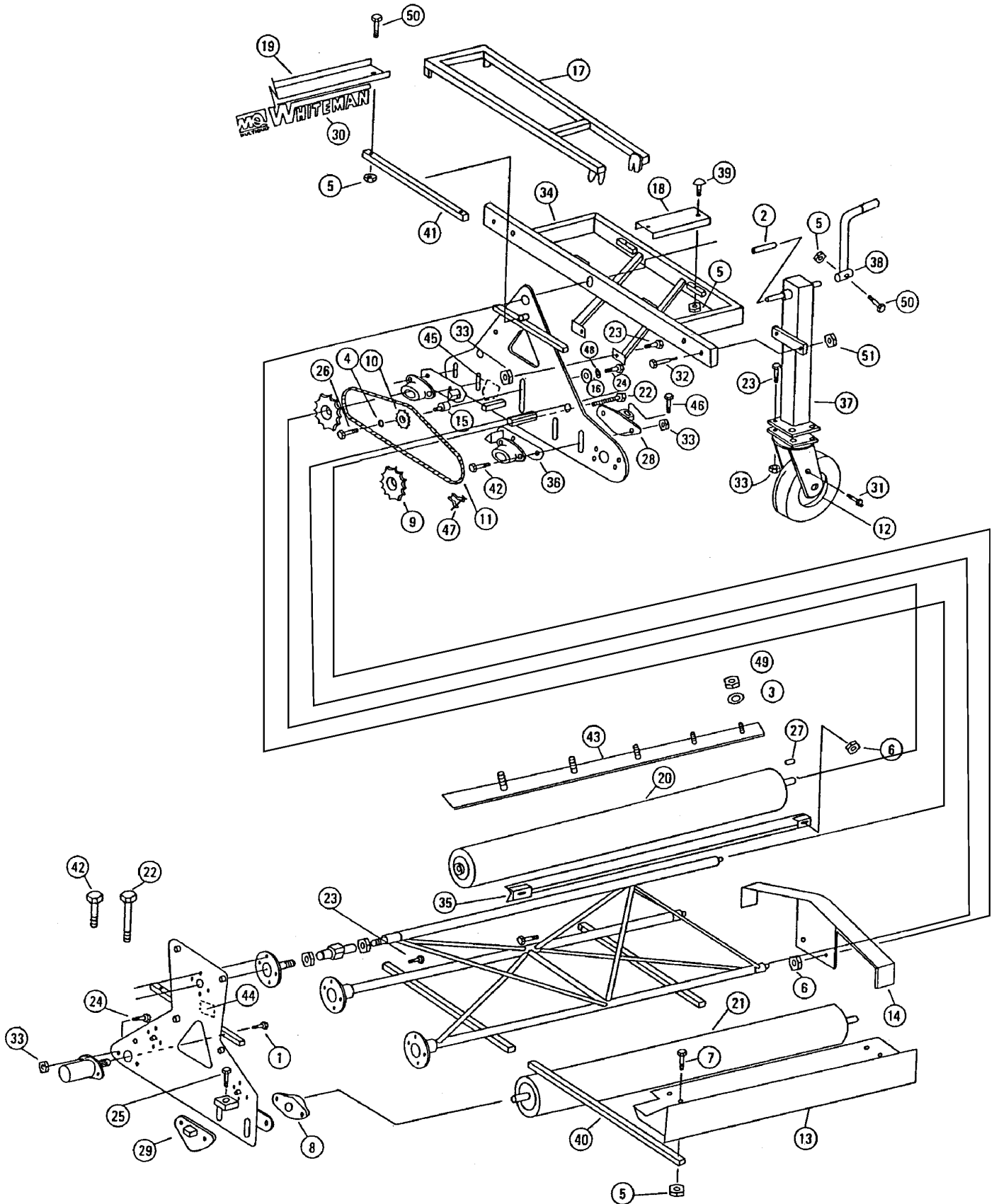

WRS-5200 — FRAME ASSEMBLY (ENGINE END)

FRAME ASSEMBLY (ENGINE END)

NO	PART NO	PART NAME	QTY.	REMARKS
1	0166	Screw, HHC 3/8 - 16 x 7/8	1	
2	0189	Grip, Handle	2	
3	0300 B	Washer, Flat, 5/16 SAE	10	
4	0448	Washer, Flat, 7/16 SAE	1	
5	10133	Nut, Nyloc 3/8 -16	14	
6	10176	Nut, Nyloc 1/2 -13	6	
7	1284	Screw, HHC 3/8 -16 x 1-1/2	4	
8	16223	Bearing, 1-3/8	3	
9	16225	Sprocket	2	
10	16226	Sprocket, Idler	1	
11	16227	Chain, Roller	1	
12	16231	Caster, (includes wheels & bracket)	2	
13	16270	Scraper Bar W/A	1	
14	16273	Chain Guard W/A	1	
15	16303	Mount, Idler Sprocket	1	
16	16372	Spacer, 1/4	1	
17	16378	Pull Handle W/A	1	
18	16442	Mount, Power, Unit Short	2	
19	16446	Mount, Power, Unit Long	2	
20	16492	Tube, Drive Rear W/A	1	
21	16493	Tube, Drive Front W/A	1	
22	16521	Screw, HHCS 1/2 -13 x 4 GD 8	4	
23	16524	Screw, HHC 1/2-13 x 1. IA GD 8	12	
24	16525	Screw, HHC 1/2 -13 x 1. 1/2 GD 8	3	
25	16529	Screw, HHC 3/4 -10 x 2 GD 8	3	

WRS-5200 — FRAME ASSEMBLY ENGINE END (CONT.)

FRAME ASSEMBLY ENGINE END (CONT.)

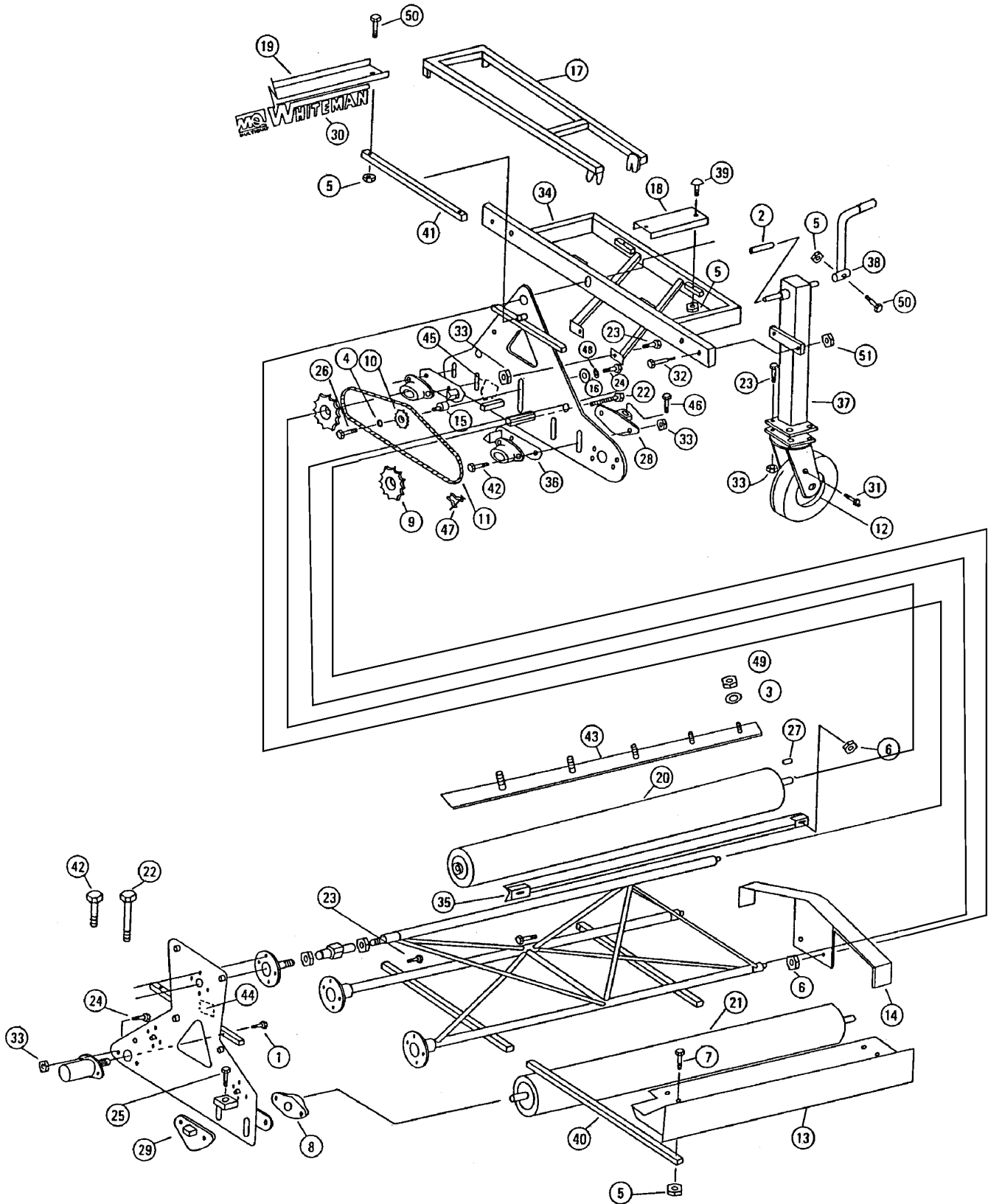

WRS-5200 — FRAME ASSEMBLY ENGINE END (CONT).

FRAME ASSEMBLY ENGINE END (CONT.)

<u>NO</u>	<u>PART NO</u>	<u>PART NAME</u>	<u>QTY.</u>	<u>REMARKS</u>
26	16530	Screw, HHC 7/16 -14 x 1	1	
27	16533	Key, 5/16 x 5/16 x 7/8	2	
28	16538	Bearing Adjustment W/A Short	2	
29	16539	Bearing Adjustment W/A Long	1	
30	16563	Decal MQ Multiquip Whiteman	2	
31	16627	Bolt, Shoulder 5/8 x ~A PLTD	4	
32	16628	Bolt, Shoulder 3/4 x - 2 1/4 PLT	4	
33	16629	Nut, Nyloc 1/2-13 GD 8	18	
34	16632	Bracket, Caster W/A (power unit end)	1	
35	16658	Wiper, Solid W/A	2	
36	16659	Mount, Solid Wiper W/A	3	
37	16683	Jack, Screed W/A	2	
38	16685	Handle, Jack W/A	2	
39	16693	Bolt, Carriage 3/8-16 x 2	4	
40	16695	Arm, Wiper W/A	2	
41	16751	Arm, Power Unit Outer Plate	1	
42	16781	Screw, HHCS 1/2-13 x 2.1/4 GD 8	8	
43	16868	Bar, Scraper W/A	2	
44	16880	Decal, Lifting Warning	1	
45	16883	Decal, Chain Drive Warning	1	
46	16890	Screw, HHC 3/4 x 2-1/2 GD5	1	
47	16927	Chain, roller Offset	1	
48	5054 A	Washer, Lock, 1/2 Medium	1	
49	5283	Nut, Nyloc 5/16-18	10	
50	9154	Screw, HHC 3/8-16 x 1-3/4	6	
51	9503	Nut, Nyloc 5/8-11	4	

WRS-5200 — CONTROL PANEL ASSY.

CONTROL PANEL ASSEMBLY

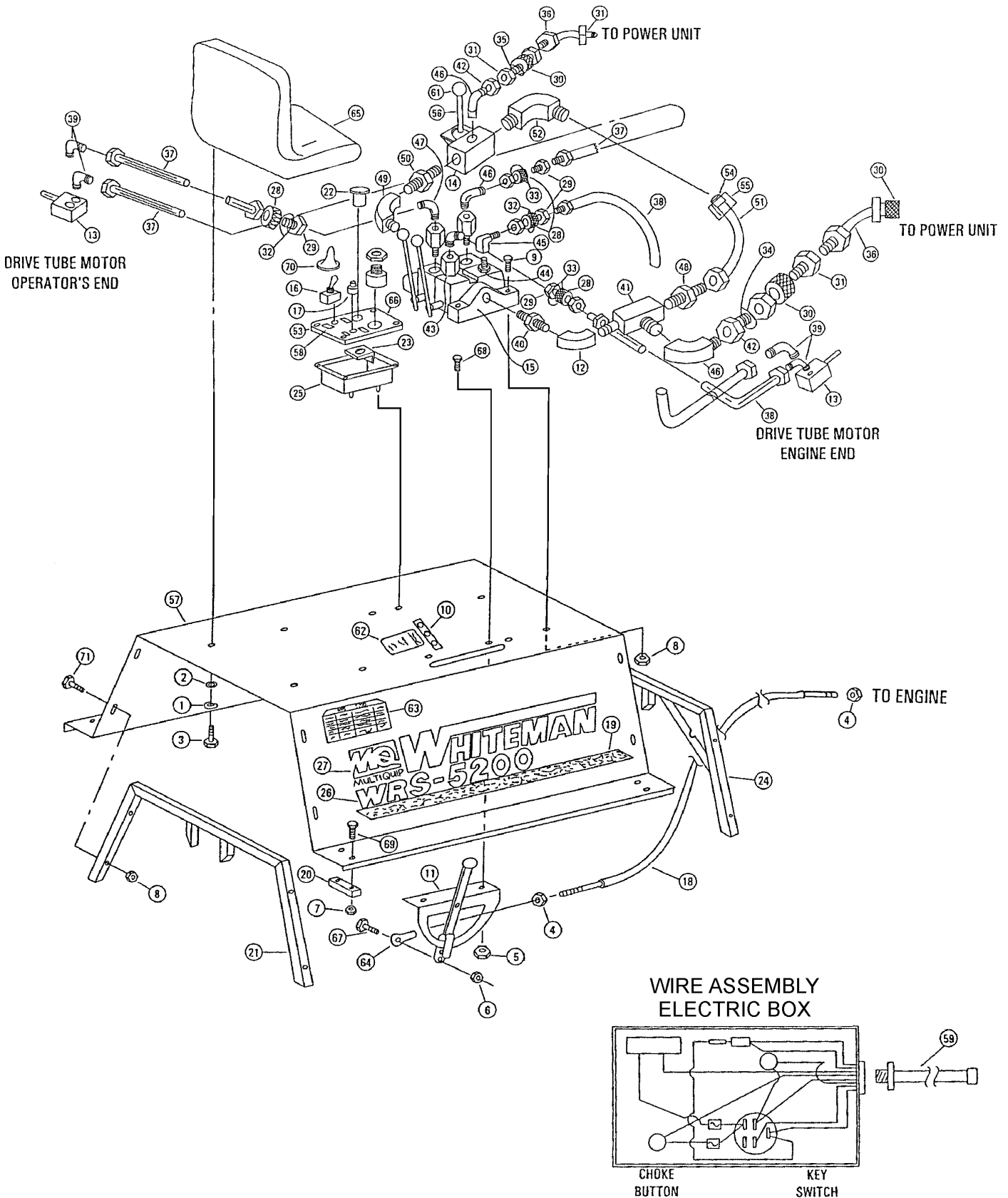

WRS-5200 — CONTROL PANEL ASSY.

CONTROL PANEL ASSEMBLY

<u>NO</u>	<u>PART NO</u>	<u>PART NAME</u>	<u>QTY.</u>	<u>REMARKS</u>
1	0161 C	Washer, Lock 5/16 Medium	4	
2	0300 B	Washer, Flat, 5/16 SAE	4	
3	0655	Screw, HHC 5/16-18 x 3/4	4	
2	0937	Nut, Hex 10-32	2	
5	0949	Nut, Flex Finish 1/4-20	2	
6	10019	Nut, Nyloc 10-32	1	
7	10024	Nut, Nyloc 1/4-20	8	
8	10133	Nut, Nyloc 3/8-16	11	
9	1023	Screw, HHC 3/8-16 x 1-1/4	3	
10	11247	Decal Set, Safety Clothing	1	
11	11379	Hand Throttle Control	1	
12	11718	Fitting, 1/2" Female Pipe 90 ELL	1	
13	16219	Motor, Drive Tube	2	
14	16220	Valve, Flow Control	1	
15	16221	Value, Stack	1	
16	16389	Switch, Toggle	1	
17	16391	Switch, Button	1	
18	16394	Cable, Tube Speed	1	
19	16402	Grid, Non-Skid	2	
20	16504	Stabilizer, Operator	4	
21	16506	Mount, Operator Guard W/A	1	
22	16510	Switch, Kill	1	
23	16511	Block, Contact	1	
24	16536	Mount, Operator Guard W/A (ENG END)	1	
25	16537	Box, Electric W/A	1	
26	16562	Decal, WRS-5200	2	
27	16563	Decal, MQ Multiquip Whiteman	2	
28	16564	Fitting, 1/2 Female QC	4	
29	16565	Fitting, 1/2 Male QC	4	
30	16566	Fitting, 3/4 Female QC	3	
31	16567	Fitting, 3/4 Male QC	3	
32	16568	1/2" Female Cover	2	
33	16569	1/2" Male Cover	2	
34	16570	3/4" Female Cover	1	
35	16571	3/4" Male Cover	1	
36	16577	Hose, 606" OAL 1/2 Hose-12NP x 12NP	2	
37	16578	Hose, 594" OAL 1/2 Hose-SNP x 8FJ	2	
38	16579	Hose, 60" OAL 1/2 Hose-SFJ x 8NP	2	
39	16580	Fitting, 10 BOSS O-R x 8MJ 45EL	4	
40	16582	Fitting, 12 BOSS O-R x 8MJ 1/2MP	1	

WRS-5200 — CONTROL PANEL ASSY. (CONT.)

CONTROL PANEL ASSEMBLY (CONT.)

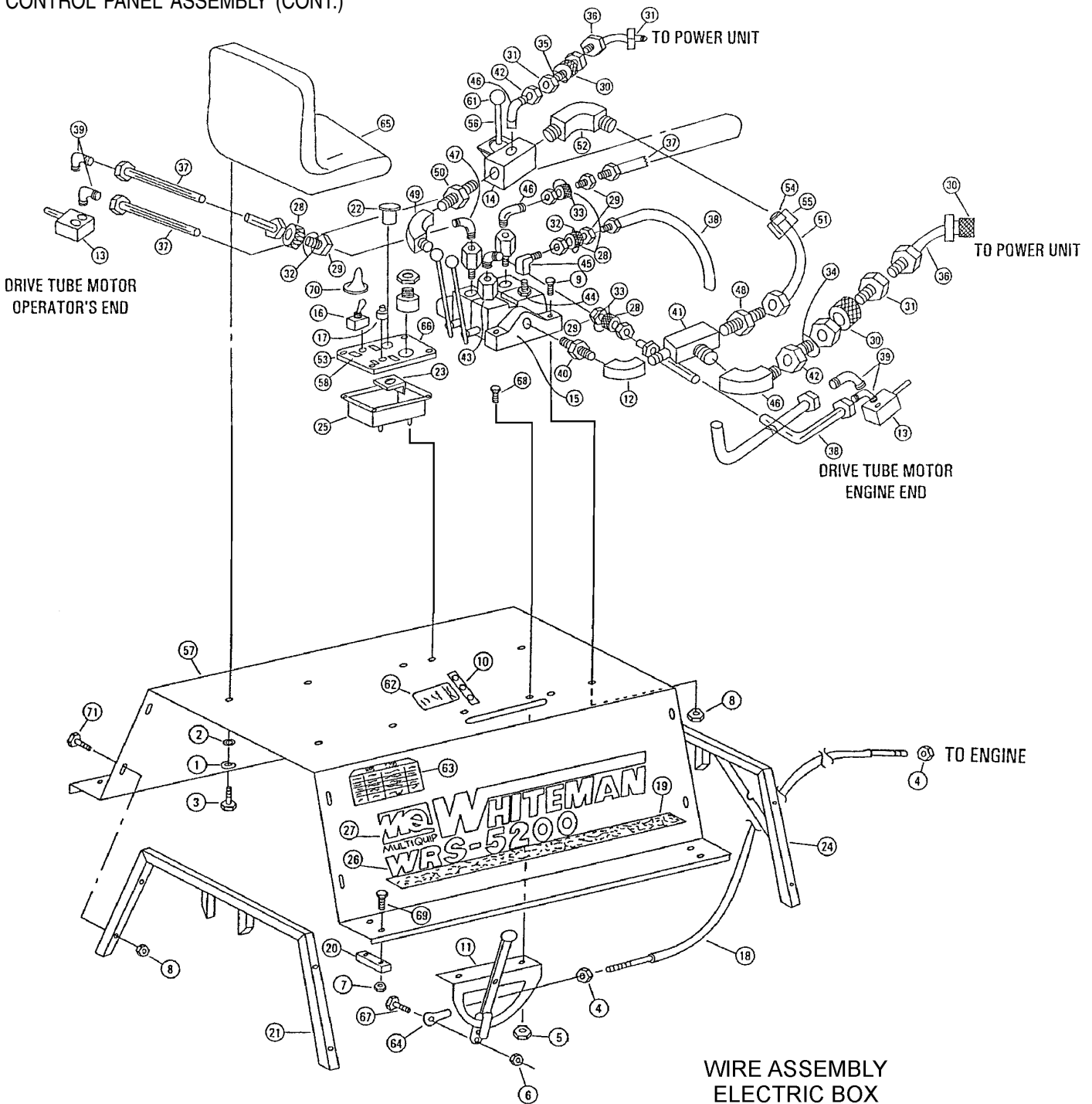

WIRE ASSEMBLY
ELECTRIC BOX

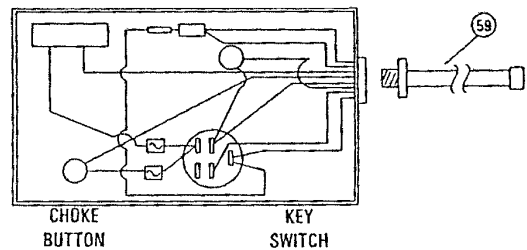

WRS-5200 — CONTROL PANEL ASSY. (CONT.)

CONTROL PANEL ASSEMBLY (CONT.)

<u>NO</u>	<u>PART NO</u>	<u>PART NAME</u>	<u>QTY.</u>	<u>REMARKS</u>
41	16583	Fitting, 1/2 Male Run TE x 1/2 FP	1	
42	16585	Fitting, Bushing 1/2 FP x 3/4 MP	2	
43	16586	Fitting, 8 BOS O-R x 1/2 FP RIG	3	
44	16587	Fitting, STRT, 80-Rx 10MJ	1	
45	16588	Fitting, 90SWVL, 10FJ x 1/2 MP	1	
46	16589	Fitting, 1/2MP x 1/2MP 90 EL	3	
47	16590	Fitting, 1/2MP x 1/2MP 45 EL	2	
48	16591	Fitting, 1/2MP x 5/SMJ	1	
49	16592	Fitting, 12 BOS O-R x 3/4 FP 90L	1	
50	16596	Fitting, 3/4MP x 1/2MP HEX NIPP	1	
51	16599	Tube, HYD STL (Stack Valve)	1	
52	16606	Fitting, 1/2MP x 5/SMJ 90 EL	1	
53	16636	Box, Electric Lid	1	
54	16717	Fitting, Ferrule 5/8 Tube HYD	1	
55	16718	Fitting, Nut 5/8 Tube HYD	1	
56	16730	Handle, Speed Control	1	
57	16748	Guard, Rider W/A	1	
58	16758	Decal, Sheet WRS-5200	1	
59	16779	Wire Asm, Control End	1	
60	16780	Wire Asm, Electric Box	1	
61	16788	Handle, Tapered	1	
62	16882	Decal, Injury Warning	1	
63	16926	Decal, Screed Set Up	1	
64	2153	Rod End, 10-32 Female RH	1	
65	2351	Seat, High Back	1	
66	2815	Harness, Onan-not for service	1	
67	3513	Screw, HHC 10-32 x 1	1	
68	4514	Screw, HHC 1/4-20 x 5/8	2	
69	5277	Screw, HHC 1/4-20 x 1-1/2	8	
70	8381	Boot, Toggle Switch	1	
71	9154	Screw, HHC 3/8-16 x 1-3/4	8	

ENGINE ASSEMBLY

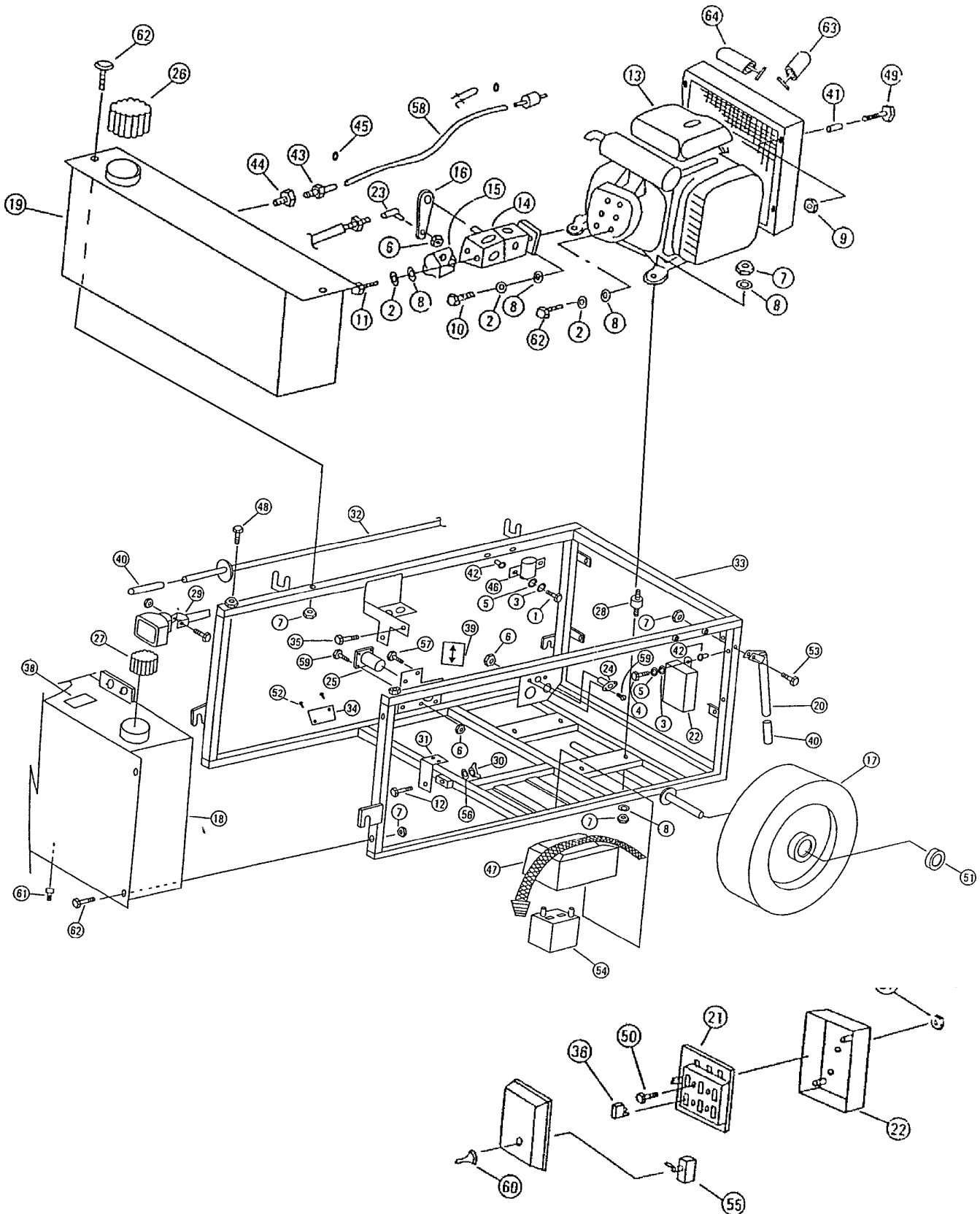

ENGINE ASSEMBLY

<u>NO</u>	<u>PART NO</u>	<u>PART NAME</u>	<u>QTY.</u>	<u>REMARKS</u>
1	0131 A	Screw, HHC 1/4-20 x 3/4	2	
2	0166 A	Washer, Lock 3/8 Medium	8	
3	0181 B	Washer, Lock 1/4 Medium	4	
4	0730	Screw, HHC 1/4-20 x 1	2	
5	0948	Washer, Flat 1/4 SAE	4	
6	10019	Nut, Nyloc 10-32	7	
7	10133	Nut, Nyloc 3/8-16	16	
8	0136	Washer, Flat 3/8 SAE	16	
9	10176	Nut, Nyloc 1/2-13	4	
10	1023	Screw, HHC 3/8-16 x 1-1/4	2	
11	1284	Screw, HHC 3/8-16 x 1-1/2	2	
12	13178	Screw, HHC 1/2-13 x 2-1/4	1	
13	16212	Engine Onan 20 HP P220G	1	
14	16214	Pump, Piston	1	
15	16215	Pump, Gear	1	
16	16216	Lever, Pump	1	
17	16233	Wheel	4	
18	16317	Tank, HYD W/A	1	
19	16320	Tank, Gas W/A	1	
20	16354	Handle, W/A	2	
21	16390	Block, Terminal	1	
22	16393	Box, Fuse	1	
23	16396	Pin, Lever Detachable	1	
24	16397	Socket, 4-Way	1	
25	16399	Socket, 9-Way	1	
26	16403	Cap, Gas	1	
27	16405	Cap, Hyd	1	
28	16406	Isolators, Vibration	4	
29	16499	Light Fixture, W/A	2	
30	16500	Nut, Wing 1/2-13	1	

WRS-5200 — ENGINE ASSY. (CONT.)

ENGINE ASSEMBLY (CONT.)

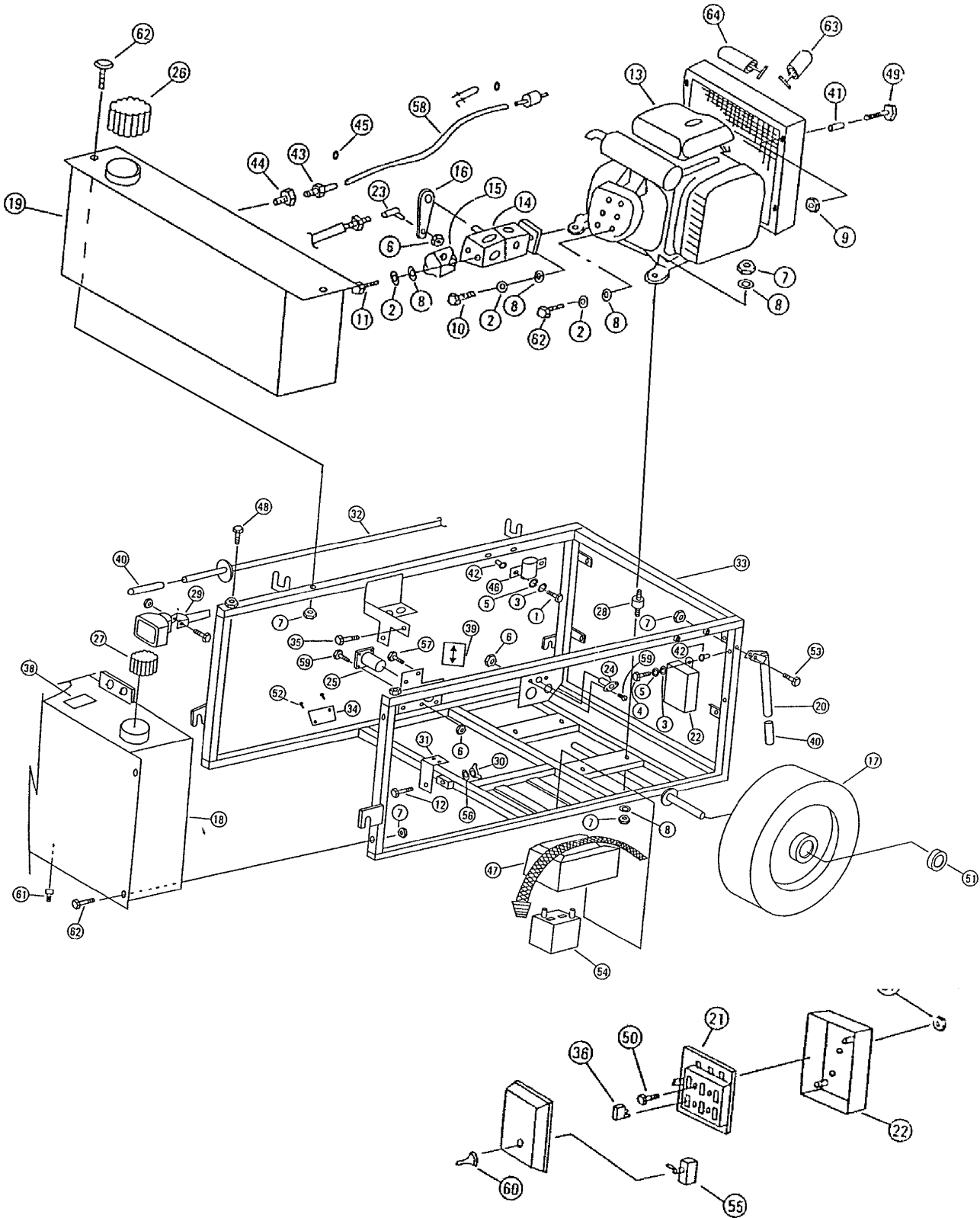

WRS-5200 — ENGINE ASSY. (CONT.)

ENGINE ASSEMBLY (CONT.)

<u>NO</u>	<u>PART NO</u>	<u>PART NAME</u>	<u>QTY.</u>	<u>REMARKS</u>
31	16501	Mount, Cable	1	
32	16535	Bar, Lift W/A	1	
33	16560	Power Unit W/A	1	
34	16689	Name Plate, Screed	1	
35	16721	Screw, HHC 3/8-24 x 1-3/4	2	
36	16722	Fuse, 20 AMP Flat Type	2	
37	16723	Nut, Hex Fin 8-32	2	
38	16882	Decal, Injury Warning	1	
39	16908	Decal, Pressure Washer	1	
40	1724	Grip, Handle QP	4	
41	19251	Spacer, 5/8 x 1/2 x 9/16 Long	4	
42	19266	Nut, Blind 1/4-20 x 10GA	4	
43	19316	Fitting, 1/4MPT x 5/16 Hose, Brass	1	
44	19317	Bushing, Reducer 3/8 x 1/4, Brass	1	
45	19473	Clamp, Worm Hose, #4 (1/4-5/8)	2	
46	2207	Solenoid, 12V	1	
47	2449	Battery Box	1	
48	2691	Screw, HHC 1/2-13 x 1	2	
49	3242	Screw, HHC 1/2-13 x 1-3/4	4	
50	3458	Screw, RMIVI 8-32 x 1	2	
51	3615	Set Collar, 3/4 id	4	
52	4014	Screw, 2-3/16 P-K Type U Drive	2	
53	4370	Screw, HHC 3/8-16 x 2-1/4	2	
54	4671	Battery, GR. UI, Wet, W/Tag	1	
55	4682	Switch, Light	1	
56	5054A	Washer, Lock, 1/2 medium	1	
57	5277	Screw, HHC 1/4-20 x 1-1/2	3	
58	60028	Hose, .312id Rubber Fuel	2	
59	8133	Screw, RHM 10-32 x 3/4	6	
60	8381	Boot, Toggle Switch	1	
61	911329	Plug, Pipe, 3/SMag. SQ Head	1	
62	9154	Screw, HHC 3/8-16 x 1-3/4	10	
63	167001	Solenoid, Choke	1	
64	16701	Solenoid, Hi/Lo	1	

WRS-5200 — FRAME ASSY.

FRAME ASSEMBLY

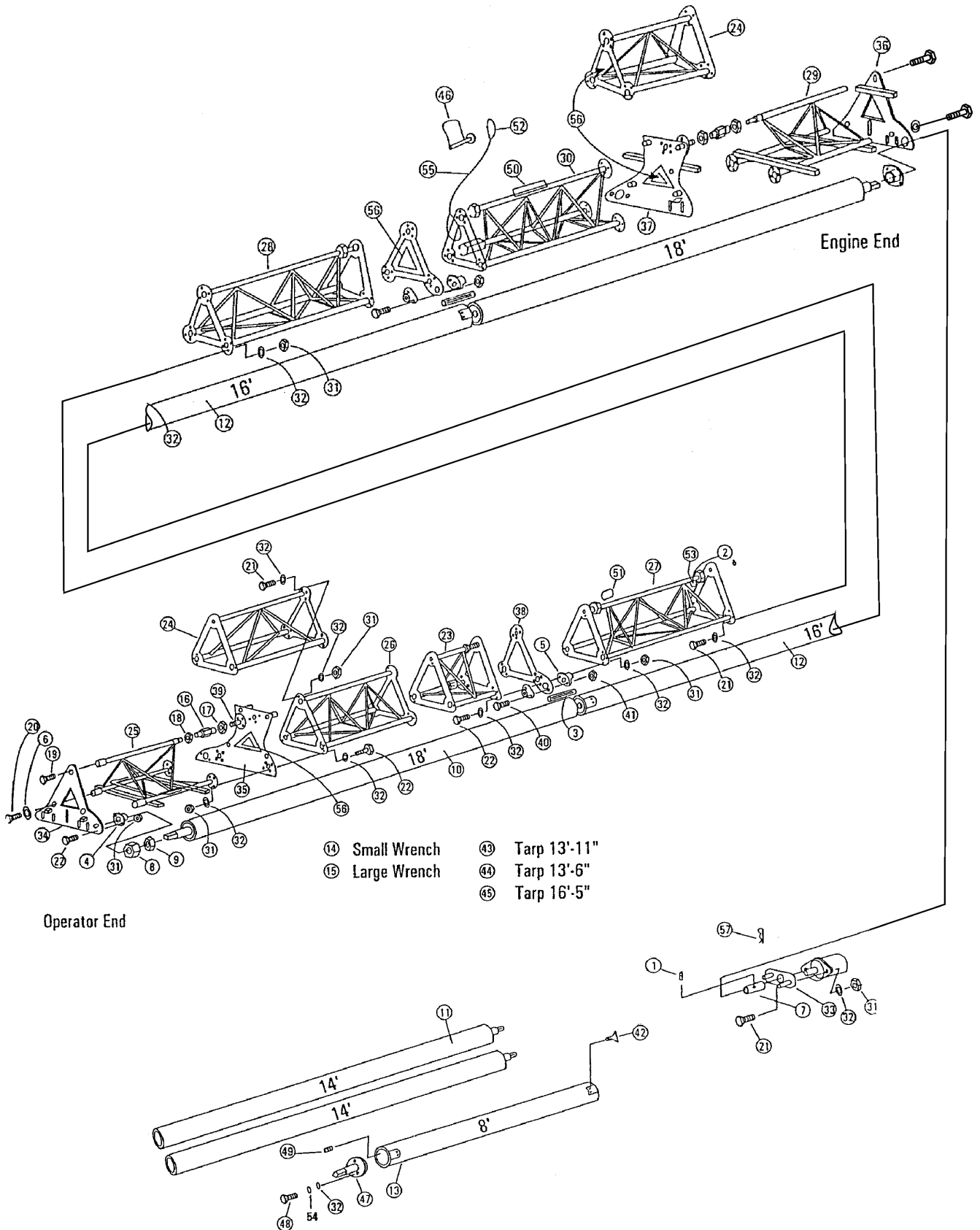

FRAME ASSEMBLY

<u>NO</u>	<u>PART NO</u>	<u>PART NAME</u>	<u>QTY.</u>	<u>REMARKS</u>
1	10138	Screw, SHS 1/4-20 x 1/2	1	
2	1162A	Cap, Grease Zerk, #2 Yellow	11	
3	16222	Shaft, Splined	2	
4	16223	Bearing, 1-3/8	2	
5	16224	Bearing, 1-1/4	4	
6	16255	Mount, Axle Power Unit	6	
7	16298	Coupling, Striker Tube	1	
8	16458	Nut, 1-5/8-12 GD 8	4	
9	16459	Nut, Jam 1-5/8-12 GD 8	4	
10	16482	Tube, Strike 18' W/A	2	
11	16483	Tube, Strike 14' W/A	2	
12	16484	Tube, Strike 16' W/A	1	
13	16485	Tube, Strike 8' W/A	1	
14	16496	Wrench, Small Double	1	
15	16497	Wrench, Large Double	2	
16	16514	Turnbuckle, 1-5/16-16	2	
17	16515	Nut, JAM 1-5/16-16 Right Hand	2	
18	16516	Nut, JAM 1-5/16-16 Left Hand	2	
19	16522	Screw, HHC 3/4-10 x 3-1/2 GD 8	2	
20	16523	Screw, HHC 3/4-10 x 3-1/2 GD 8	6	
21	16525	Screw, HHC 1/2-13 x 1-1/2 GD 8	50	
22	16526	Screw, HHC 1/2-13 x 1-3/4 GD 8	52	
23	16544	Frame, 3' W/A	1	
24	16546	Frame, Section 4' Operator End	2	
25	16547	Frame, Section 5' Operator End	1	

WRS-5200 — FRAME ASSY. (CONT)

FRAME ASSEMBLY (CONT.)

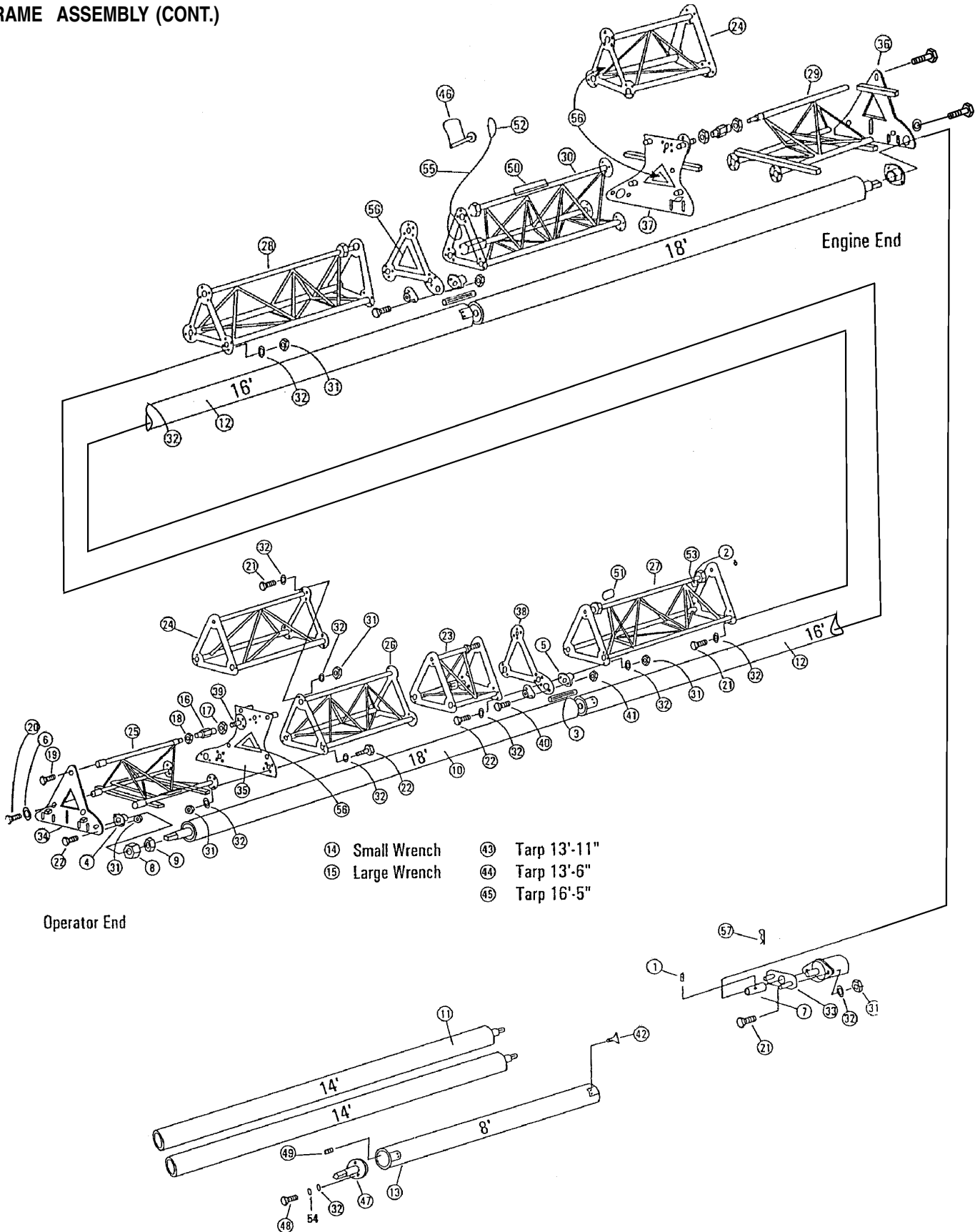

FRAME ASSEMBLY (CONT.)

<u>NO</u>	<u>PART NO</u>	<u>PART NAME</u>	<u>QTY.</u>	<u>REMARKS</u>
26	16548	Frame, Section 6'	1	
27	16549	Frame, Section 8' Oper End	1	
28	16550	Frame, Section 8' Engine End	1	
29	16551	Frame, Section 5' Engine End	1	
30	16552	Frame, Section 9'	1	
31	16629	Nut, Nyloc 1/2-13 GD 8	102	
32	16630	Washer, Flat, 1/2 Hardened PLT	196	
33	16631	Mount, Strike Tube Motor	1	
34	16633	Plate, Outer W/A Oper End	1	
35	16634	Plate, Inner W/A Oper End	1	
36	16648	Plate Outer W/A Engine End	1	
37	16649	Plate, Inner W/A Engine End	1	
38	16653	Bracket, Middle W/A	2	
39	16667	Turnbuckle, Drive Tube W/A	2	
40	16676	Screw, HHC 7/16-14 x 2" GD 8	4	
41	16677	Nut, Nyloc 7/16-14 GD 8	4	
42	16699	Screw, FHM 1/4-20 x 1/2 PLTD	8	
43	16727	Tarp, 13'-11"	1	
44	16728	Tarp, 13'-6"	1	
45	16729	Tarp, 16'-5"	1	
46	16743	Pin, Section Safety Snap	5	
47	16756	Hub, Strike Tube Aux.	1	
48	16781	Screw, HHCS 1/2-13 x 2. 1/4 GD 8	2	
49	16786	Screw, SHS 1/2-13 x 3/4	16	
50	16880	Decal, Lifting Warning	5	
51	16925	Decal, Lube and Lifting	1	
52	19485	Ferrule, Copper 1/6	10	
53	2621	Fitting, Grease, Strt, IA-28	5	
54	5054 A	Washer, Lock, V2 Medium	2	
55	60035	Wire Rope, 1/16dia Galvanized	2	
56	60055	Trim Edge, 1-1/4", (BLT 1/4)	23	
57	7170	Pin, Hitch Clip, 5/32 x 3-5/16	1	

WRS-5200 — HYDRAULIC ASSY.

HYDRAULIC ASSEMBLY

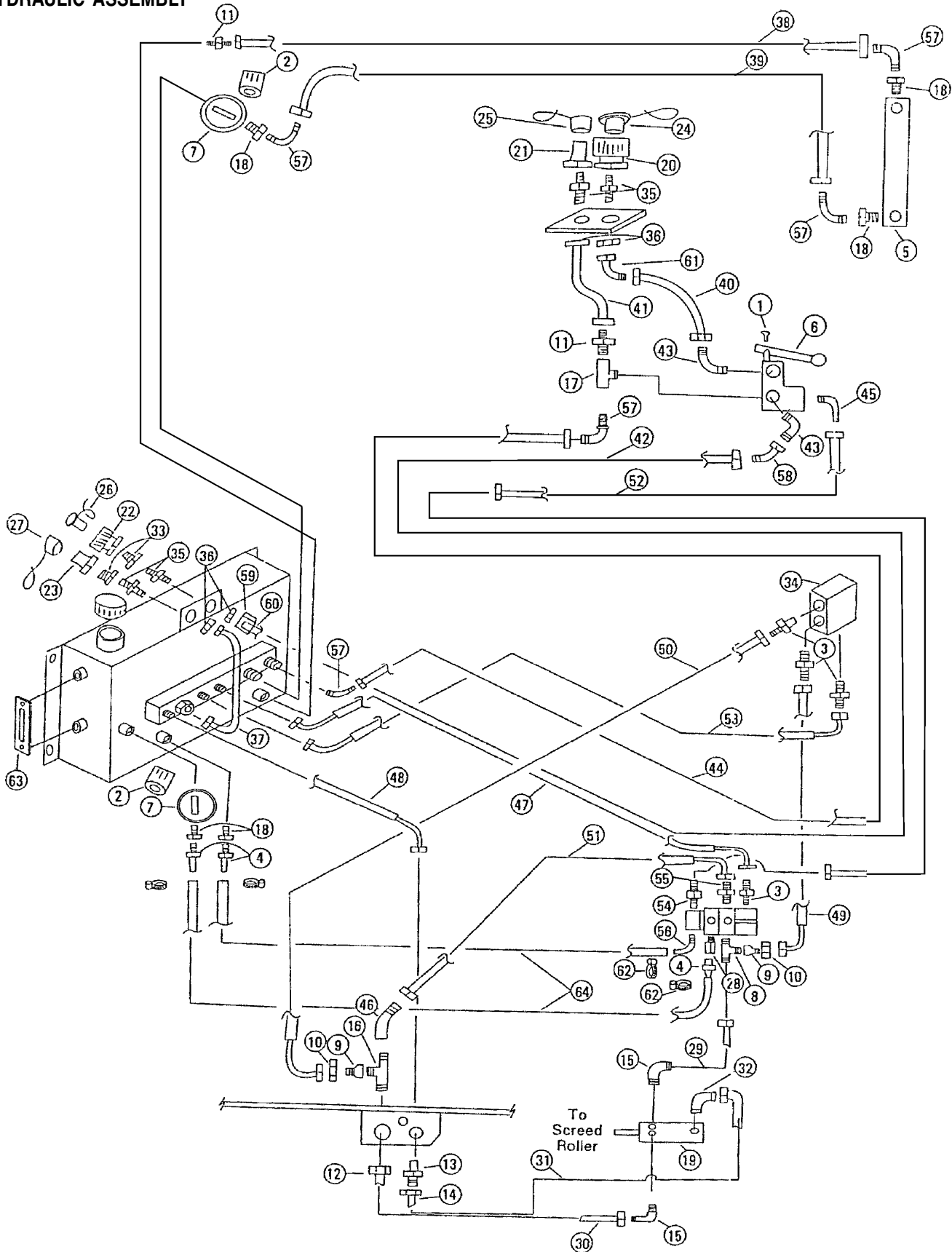

HYDRAULIC ASSEMBLY

<u>NO</u>	<u>PART NO</u>	<u>PART NAME</u>	<u>QTY.</u>	<u>REMARKS</u>
1	0786	Screw, BHC 1/4-20 x 3/8 Nyloc	1	
2	11402	Filter, Hyd Oil	2	
3	11721	Fitting-06MO-R x -06MJIC	4	
4	13220	Fitting, Strt, 3/4 MPT x 3/4 Barb	3	
5	16213	Cooler, Hyd Oil	1	
6	16217	Valve, Selector, 3-way	1	
7	16218	Filter, Head	2	
8	16327	Fitting, 3/4 BOS Run J Tee	1	
9	16328	Fitting, 3/4 FJ x 3/8 MJ Reducer	2	
10	16329	Fitting, 3/4JFX x Tube Nut	2	
11	16331	Fitting, 3/4 MP x 5/8J	2	
12	16332	Fitting, Bulkhead Nut, 5/8	1	
13	16333	Fitting, 3/8J x 3/8J	1	
14	16334	Fitting, Bulkhead Nut, 3/8	1	
15	16336	Fitting, 10 BOS O-R x 10MJ 45EL	2	
16	16340	Tee, Bulkhead 3/4 Run	1	
17	16344	Fitting, Tee 3/4 MP x 3/4 FP	1	
18	16346	Bushing, 1-3/4	5	
19	16409	Motor, Strike Tube	1	
20	16564	Fitting, 1/2 Female QC	1	
21	16565	Fitting, 1/2 Male QC	1	
22	16566	Fitting, 3/4 Female QC	1	
23	16567	Fitting, 3/4 Male QC	1	
24	16568	1/2" Female Cover	1	
25	16569	1/2" Male Cover	1	
26	16570	3/4" Female Cover	1	
27	16571	3/4" Male Cover	1	
28	16572	Fitting, 8 BOSS O-Ring x 3/4 FPT (RIGID)	1	
29	16574	Hose, 80" OAL 5/8 Hose-10 FJ x 12 FJ	1	
30	16575	Hose, 75" OAL 5/8 Hose-10 FJ x 12 FJ	1	

WRS-5200 — HYDRAULIC ASSY. (CONT)

HYDRAULIC ASSEMBLY (CONT.)

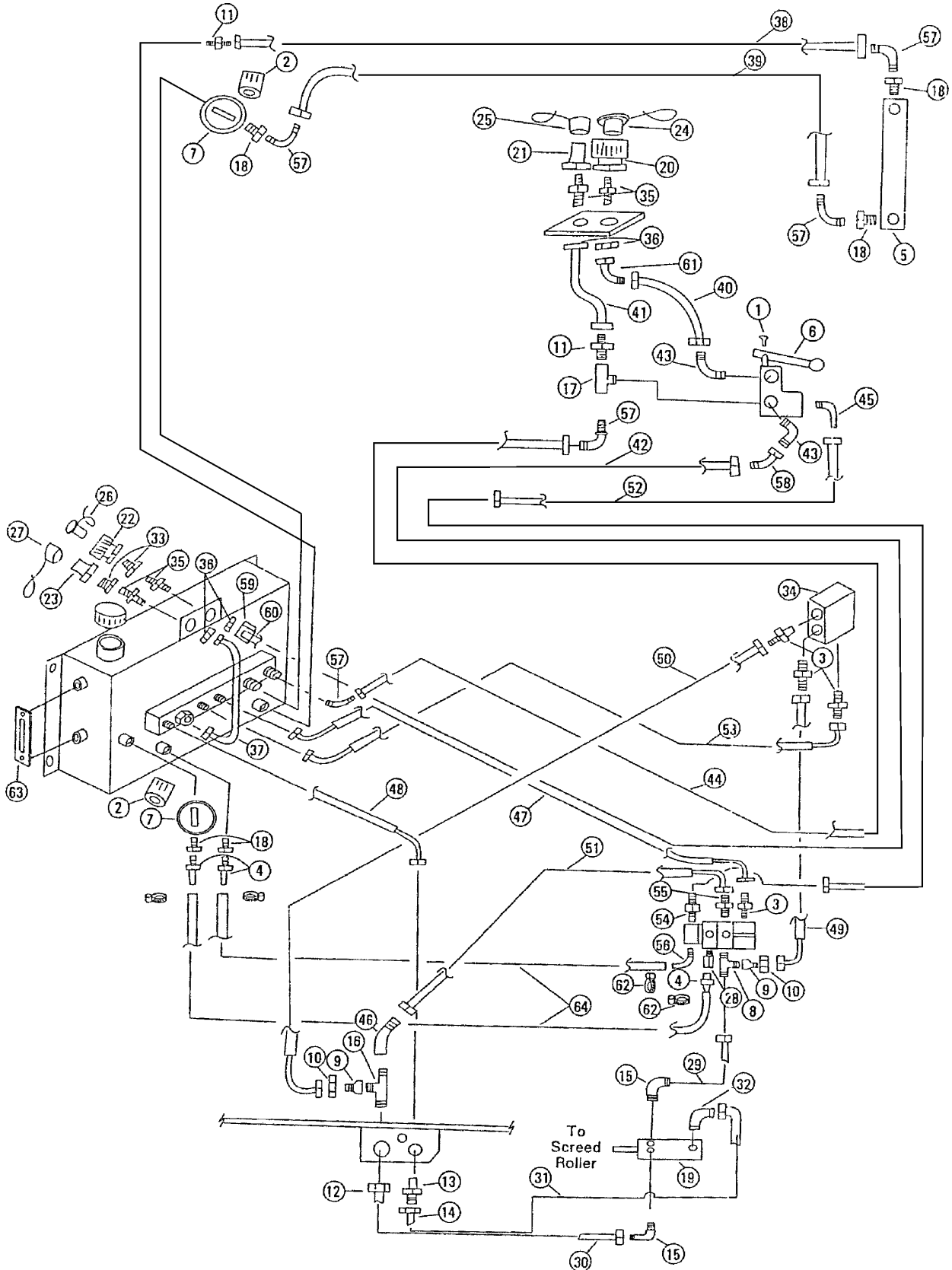

WRS-5200 — HYDRAULIC ASSY. (CONT)

HYDRAULIC ASSEMBLY (CONT.)

<u>NO</u>	<u>PART NO</u>	<u>PART NAME</u>	<u>QTY.</u>	<u>REMARKS</u>
31	16576	Hose, 75" OAL 3/8 Hose-3/8 FJ x 3/8 FJ	1	
32	16581	Fitting, 4 BOSS O-R x 6 MJ 90 ELB	1	
33	16585	Fitting, Bushing 1/2 FP x 3/4 MP	2	
34	16594	Valve, Loop Flushing	1	
35	16597	Fitting, 1/2 MP x 5/8 MJ Bulkhead	4	
36	16598	Nut, 5/8 Bulkhead	4	
37	16660	Tube, HYD Steel (Manifold to HYD Tank)	1	
38	16601	Tube, HYD Steel (PAD. Return)	1	
39	16602	Tube, HYD Steel (PAD. Supply)	1	
40	16603	Tube, HYD Steel (Valve to Female QC)	1	
41	16604	Tube, HYD Steel (Valve to Male QC)	1	
42	16605	Tube, HYD Steel (Valve to Tank)	1	
43	16606	Fitting, 1/2 MP x 5/8 MJ 90 EL	2	
44	16607	Tube, HYD Steel (Valve to Manifold)	1	
45	16608	Fitting, 3/4 MP x 8 MJ 90 EL	1	
46	16609	Fitting, 12 FJ (SWIV) x 12 MJ 45 EL	1	
47	16610	Hose, 6C2AT-69FJX-64FJX	1	
48	16611	Hose, 6C2AT-6FJX-64FJX	1	
49	16612	Hose, 6C2AT-6FJX-69FJX	1	
50	16613	H6se, 6C2AT-6FJX-69FJX	1	
51	16614	Hose, 12C2AT-129FJX-12FJX	1	
52	16615	Hose, 8C2AT-89FJX-SFJX	1	
53	16616	Hose, 6C2AT-6FJX-69FJX	1	
54	16617	Fitting, 10 BOS O-Rx 8 MJ	1	
55	16618	Fitting, 12 BOS O-R x 12 MJ Strt	1	
56	3461	Fitting, 12 BOS O-RxV4Bar90EL	1	
57	3368	Fitting, 3/4 MP x 5/8 MJ 90 EL	5	
58	16698	Fitting, 5/8 FJ x 5/8 MJ 45 EL	1	
59	16717	Fitting, Ferrule 5/8 Tube HYD	7	
60	16718	Fitting, Nut 5/8 Tube HYD	7	
61	16846	Fitting, 5/8 FJ x5/8 MJ 90 Elbow	1	
62	3333	Clamp, 1-1/4 Hose	4	
63	3336	Gauge, Temp Sight	1	
64	3462	Hose, Suction	2	

WRS-5200 — PRESSURE WASHER ASSY.

PRESSURE WASHER ASSEMBLY

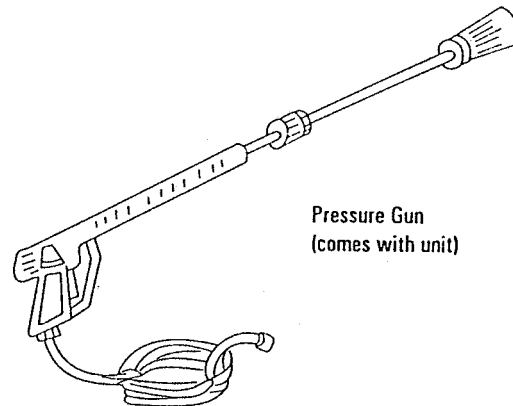
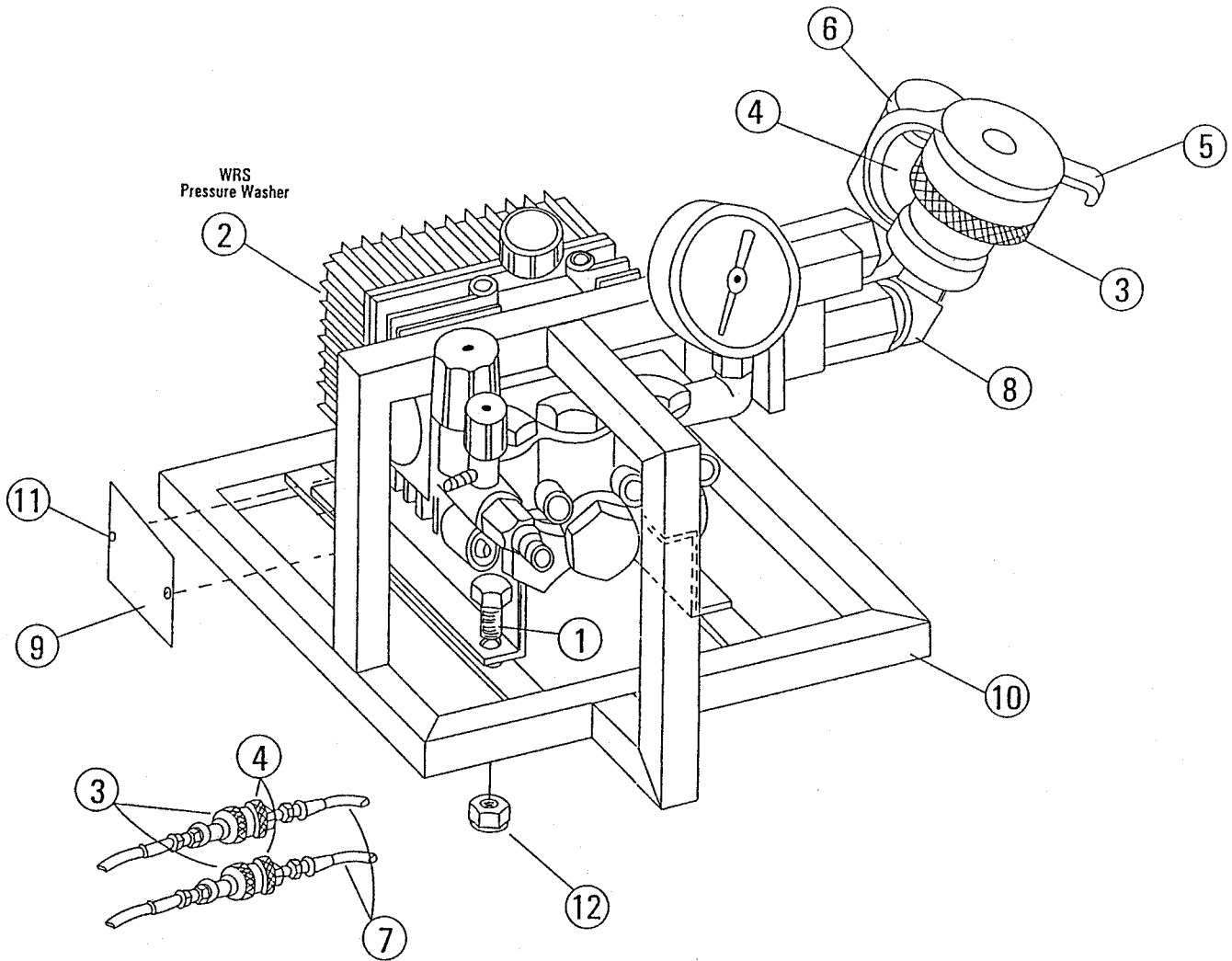

WRS-5200 — PRESSURE WASHER ASSY.

PRESSURE WASHER ASSEMBLY

<u>NO</u>	<u>PART NO</u>	<u>PART NAME</u>	<u>QTY.</u>	<u>REMARKS</u>
1	0655	Screw, HHC 5/16-18 x 3/4	4	
2	16407	Washer, Pressure	1	
3	16564	Fitting, 1/2 Female QC	3	
4	16565	Fitting, 1/2 Male QC	3	
5	16568	1/2" Female Cover	1	
6	16569	1/2" Male Cover	1	
7	16573	Hose, OAL 74", 1/2 Hose-SMNP x 8MNP	2	
8	16590	Fitting, 1/2 MP x 1/2 MP 45 EL	2	
9	16689	Name Plate, Screed	1	
10	16741	Pressure Washer W/A	1	
11	4014	Screw, 2-3/16 P-K Type U Drive	2	
12	5283	Nut, Nyloc 5/16-18	4	

WIRE ASSEMBLY

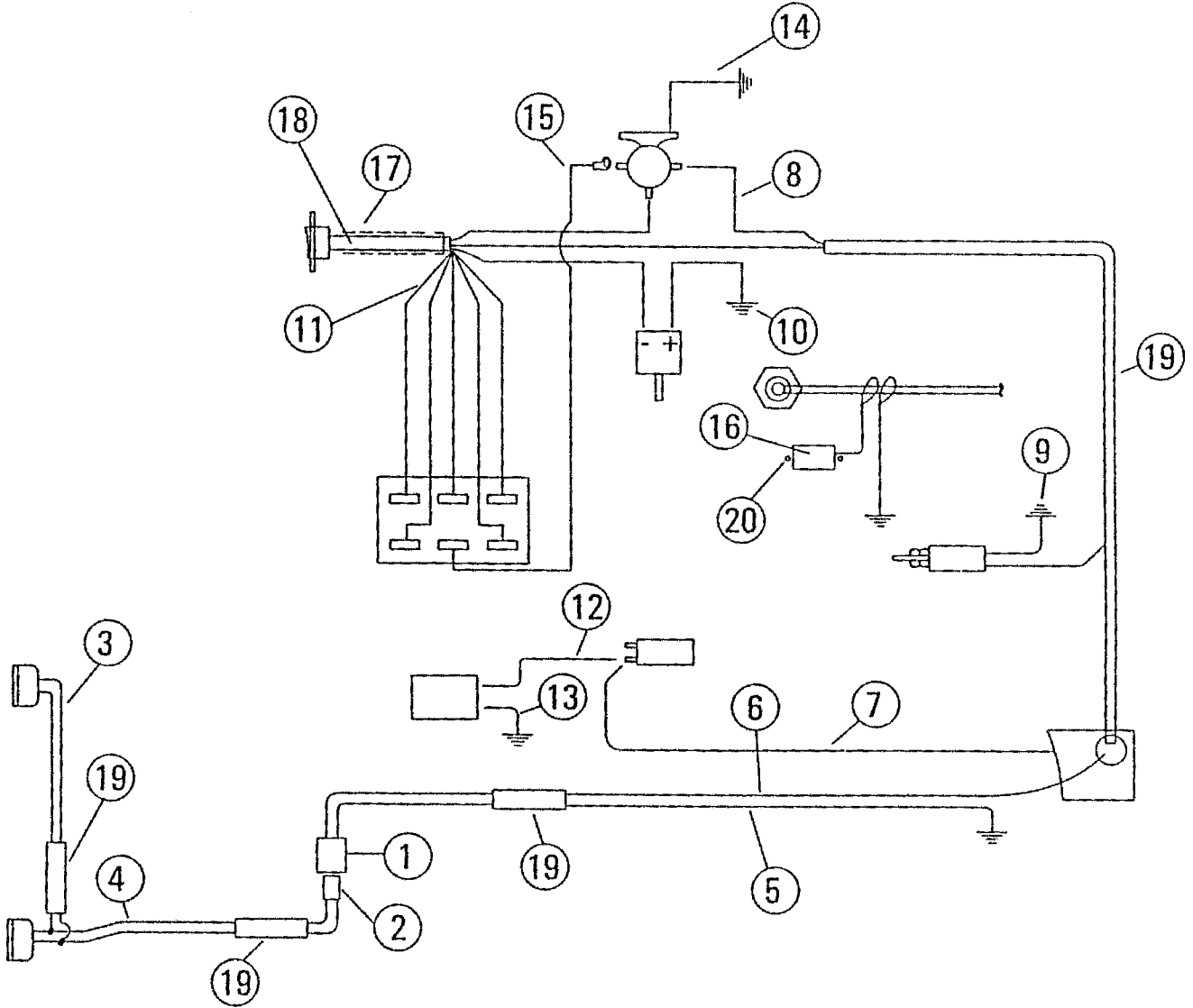

WIRE ASSEMBLY

<u>NO</u>	<u>PART NO</u>	<u>PART NAME</u>	<u>QTY.</u>	<u>REMARKS</u>
1	16397	Socket, 4-Way	1	
2	16398	Plug, 4-Way	1	
3	16759	Wire, Lite to Lite Power Unit	2	
4	16760	Wire, Lite to Socket Power Unit	2	
5	16761	Wire, Grd to 4 SCK Power Unit	1	
6	16762	Wire, Socket to Fuse Power Unit	1	
7	16763	Wire, SOL to Fuse Power Unit	1	
8	16764	Wire, Start SOL-Fuse Power Unit	1	
9	16776	Wire, Choke to GRD Power Unit	1	
10	16777	Wire, HI/LO to BATT Power Unit	1	
11	16778	Main Wire ASM, Power Unit	1	
12	16782	Wire, SOL to GILD Power Unit	1	
13	16783	Wire, BATT to GILD Power Unit	1	
14	16784	Wire, ST Rel to GRD Power Unit	1	
15	16785	Wire, ST Rel to Junc Power Unit	1	
16	2655	Hour meter	1	
17	60037	Loom, 5/8 dia HI Temp, Black	3	
18	60056	12/16 Sow	4	
19	60221	Loom, .375 Split	9	
20	8239	Rivet, Pop 1/8 x .400	2	

TERMS AND CONDITIONS OF SALE — PARTS

PAYMENT TERMS

Terms of payment for parts are net 10 days.

FREIGHT POLICY

All parts orders will be shipped collect or prepaid with the charges added to the invoice. All shipments are F.O.B. point of origin. Multiquip's responsibility ceases when a signed manifest has been obtained from the carrier, and any claim for shortage or damage must be settled between the consignee and the carrier.

MINIMUM ORDER

The minimum charge for orders from Multiquip is \$15.00 net. Customers will be asked for instructions regarding handling of orders not meeting this requirement. If possible, additional fast moving parts will be added to the order to total \$15.00 minimum.

RETURNED GOODS POLICY

Return shipments will be accepted and credit will be allowed, subject to the following provisions:

1. A Returned Material Authorization must be approved by Multiquip prior to shipment. A copy of the Authorization must accompany the shipment to the designated Warehouse. A copy of the original Multiquip invoice to the customer must also accompany the shipment.
2. Parts being returned must be listed as currently supplied on the current parts list.
3. Parts must be in new and resalable condition, in the original Multiquip package, with Multiquip part numbers clearly marked.

4. Any item with a list price of \$1.00 or less will not be accepted.
5. Any parts with a limited shelf life (such as gaskets, seals, "O" rings, filters, etc.) that are over six months old will not be accepted.
6. Special order items are not returnable for credit.
7. Engine parts other than 2-cycle engine parts will not be accepted.
8. Credit on returned parts will be issued at dealer net price at time of original purchase, less a 15% restocking charge.
9. Credit issued will be applied to future purchases only.
10. All parts must be returned freight prepaid to Multiquip's designated receiving point. Freight is at the sender's expense.

The sender will be notified of any material received not meeting the above provisions. Such material will be held for 30 days from notification, pending instructions. If a reply is not received within 30 days, the material will be returned to the seller at his expense.

PRICING AND REBATES

Prices are subject to change without prior notice.

Price changes are effective on a specific date and all shipments on or after that date will be billed at the revised price.

Rebates for price declines and added charges for price increases will not be made for stock on hand at the time of any price change.

Multiquip reserves the right to quote and sell direct to Government agencies, and to Original Equipment Manufacturer accounts who use our products as integral parts of their own products.

SPECIAL EXPEDITING SERVICE

A \$20.00 to \$50.00 surcharge will be added to the invoice for special handling including bus shipments, insured parcel post or in cases where Multiquip must personally deliver the parts to the carrier.

LIMITATION OF SELLER'S LIABILITY

Multiquip shall not be liable hereunder for damages in excess of the purchase price of the item with respect to which damages are claimed, and in no event shall Multiquip be liable for loss of profit or good will or for any other special, consequential or incidental damages.

LIMITATION OF WARRANTIES

No warranties, express or implied, are made in connection with the sale of parts or trade accessories nor as to any engine not manufactured by Multiquip. Such warranties made in connection with the sale of new, complete units are made exclusively by a statement of warranty packaged with such units, and Multiquip neither assumes nor authorizes any person to assume for it any other obligation or liability whatever in connection with the sale of its products. Apart from such written statement of warranty, there are no warranties, express, implied or statutory, which extend beyond the description of the products on the face hereof.

PARTS MANUAL

HERE'S HOW TO GET HELP

*PLEASE HAVE THE MODEL AND SERIAL NUMBER
ON-HAND WHEN CALLING*

PARTS DEPARTMENT

800/427-1244 or 310/537-3700

FAX: 800/672-7877 or 310/637-3284

SERVICE DEPARTMENT

800/478-1244 or 310/537-3700

FAX: 310 - 537-4259

WARRANTY DEPARTMENT

800/421-1244, EXT. 279 or 310/537-3700

FAX: 310 - 537-1173

MAIN

800/421-1244 or 310/537-3700

FAX: 310 - 537-3927



MULTIQUIP INC.

POST OFFICE BOX 6254

CARSON, CA 90749

310-537-3700 • 800-421-1244

FAX: 310-537-3927

E-MAIL: mq@multiquip.com

WWW: multiquip.com

Atlanta • Boise • Dallas • Houston • Newark
Quebec, Canada • Manchester, UK • Rio De Janeiro, BR • Guadalajara, MX