

# OPERATION MANUAL



***WHITEMAN* SERIES**  
**MODEL CA4-4HM**  
**WALK-BEHIND TROWEL**  
**(HONDA GASOLINE ENGINE)**

**PRELIMINARY**

Revision #2 (09/06/04)

**THIS MANUAL MUST ACCOMPANY  
THE EQUIPMENT AT ALL TIMES.**



# WARNING



## **CALIFORNIA — Proposition 65 Warning**

Engine exhaust and some of its constituents, and some dust created by power sanding, sawing, grinding, drilling and other construction activities contains chemicals known to the State of California to cause cancer, birth defects and other reproductive harm. Some examples of these chemicals are:

- Lead from lead-based paints.
- Crystalline silica from bricks.
- Cement and other masonry products.
- Arsenic and chromium from chemically treated lumber.

Your risk from these exposures varies, depending on how often you do this type of work. To reduce your exposure to these chemicals: **ALWAYS** work in a well ventilated area, and work with approved safety equipment, such as dust masks that are specially designed to filter out microscopic particles.

## **HERE'S HOW TO GET HELP**

PLEASE HAVE THE MODEL AND SERIAL  
NUMBER *ON-HAND* WHEN CALLING

### ***MULTIQUIP'S MAIN PHONE NUMBERS***

800-421-1244      FAX: 310-537-3927  
310-537-3700

### ***PARTS DEPARTMENT***

800-427-1244      FAX: 800-672-7877  
310-537-3700      FAX: 310-637-3284

### ***MAYCO PARTS***

800-306-2926      FAX: 800-672-7877  
310-537-3700      FAX: 310-637-3284

### ***SERVICE DEPARTMENT***

800-478-1244      FAX: 310-537-4259  
310-537-3700

### ***MQ POWER SERVICE DEPARTMENT***

800-835-2551      FAX: 310-638-8046  
310-537-3700

### ***TECHNICAL ASSISTANCE***

800-478-1244      FAX: 310-631-5032

### ***WARRANTY DEPARTMENT***

800-421-1244, EXT. 279      FAX: 310-537-1173  
310-537-3700, EXT. 279

Your Local Dealer is:



## MQ WHITEMAN CA4-4HM WALK-BEHIND TROWEL

Here's How To Get Help .....	3
Table Of Contents .....	4
Dimensions .....	5
Specifications .....	6
Training Checklist .....	8
Daily Pre-Operation Checklist .....	9
Safety Message Alert Symbols .....	10-11
Rules For Safe Operation .....	12-13
Operation And Safety Decals .....	14
General Information .....	15
Controls and Components .....	16
Basic Engine .....	17
Assembly .....	18
Pre-Inspection .....	19-20
Initial Start-Up .....	21-22
Operation .....	23-24
Options .....	25
Maintenance .....	26-31
Troubleshooting (Trowel) .....	33-34
Troubleshooting (Engine) .....	35
Terms and Condition Of Sale — Parts .....	37

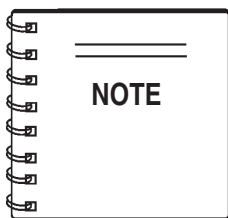

***Specifications and part numbers are subject to change without notice.***

# CA4-4HM TROWEL— DIMENSIONS

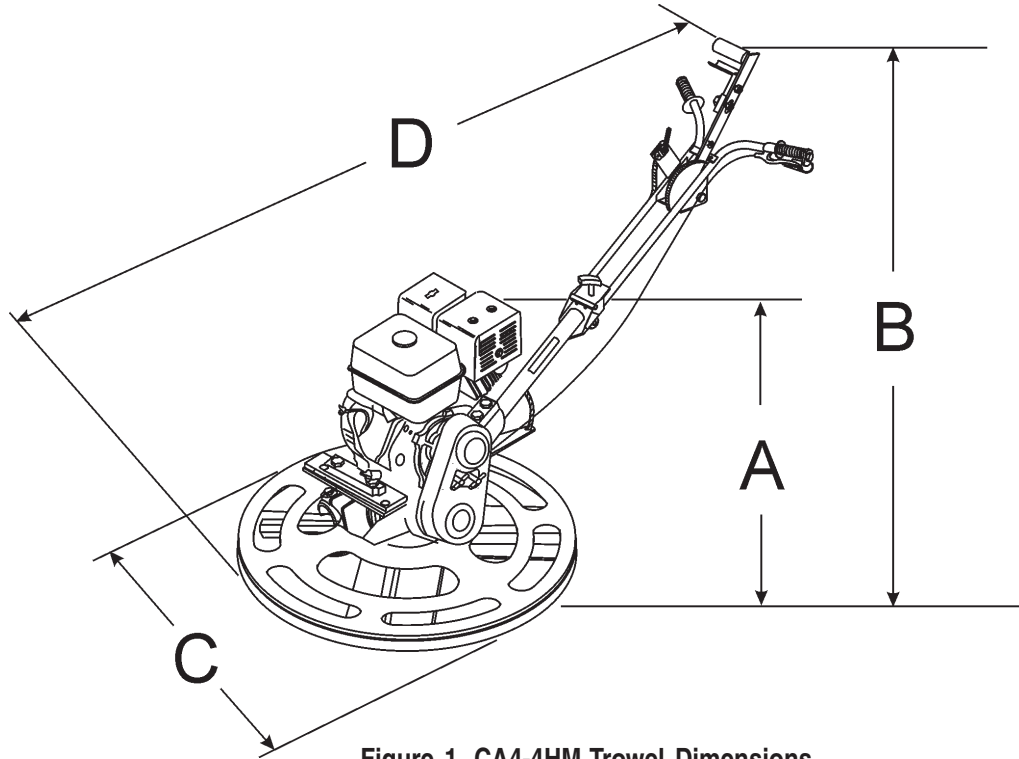

Figure 1. CA4-4HM Trowel Dimensions

**Table 1. CA4-4HM Trowel Dimensions & Weight**

A-Height (Lifting Bale)	711 mm (28.0 in.)
B - Height (Engagement Lever)	921 mm (36.25 in.)
C - Width	610 mm (24 in.)
D - Length	1.55 m (5.08 ft.)
Weight	57 kg (125 lbs.)

# CA4-4HMTROWEL— SPECIFICATIONS

## Table 2. CA4-4HM Trowel Specifications

Number of Blades	4
Ring Diameter	24.0 in. (61 cm.)
Rotor	70-130 RPM
Path Width	24 in. (61 cm.)
Vibration (Hand/Arm) <sup>1</sup>	18.9 m/s <sup>2</sup>
Sound Pressure (A-Weighted) <sup>2</sup>	83.5 dB(A)
Sound Pressure (Peak, C-Weighted)	90.5 dB(C)
Sound Power Level (A-Weighted)	97 dB(A)

### NOTE:

1. The vibration level indicated is the maximum RMS (Root Mean Square) value obtained at the handle grip while operating the walk-behind trowel at full throttle on steel plate with blades partially pitched.
2. Sound pressure is a weighted measure. It is measured at the operator's ear position while the walk-behind trowel is operating at full throttle on concrete in a manner most often experienced in "**normal**" circumstances. Sound pressure may vary depending upon the condition of the concrete.

## Table 3. Engine Specifications

<b>Engine</b>	<b>Model</b>	<b>HONDA GX120K1QX2</b>
	Type	4-stroke, Overhead valve, Single Cylinder
	Bore X Stroke	2.4 in. X 1.7 in. (60 mm x 42 mm)
	Displacement	7.3 cu. in. (119 cc)
	Max Output	3.9 H.P. (2.9 kW, 4.0 PS) at 3,600 R.P.M.
	Fuel Tank Capacity	Approx. 0.66 U.S. Gallons (2.5 Liters)
	Standard Idle Speed	1,400 +200/-150 R.P.M.
	Fuel	Unleaded Gasoline
	Lube Oil Capacity	0.63 U.S. Quarts (0.60 Liters)
	Speed Control Method	Centrifugal Fly-weight Type
	Starting Method	Recoil Start
<b>Dimension (L x W x H)</b>	11.7 x 13.4 X 12.5 in. (297 X 341 X 318 mm)	
<b>Dry Net Weight</b>	28.7 lbs. (13.0 Kg.)	



# CA4-4HM TROWEL— TRAINING CHECKLIST

## TRAINING CHECKLIST

This checklist will lists some of the minimum requirements for machine maintenance and operation. Please feel free to detach it and make copies. Use this checklist whenever a new operator is to be trained or it can be used as a review for more experienced operator's.

TRAINING CHECKLIST			
NO.	DESCRIPTION	OK?	DATE
1	Read Operator's Manual completely.		
2	Machine layout, location of components, checking of engine and gearbox fluid level.		
3	Fuel system, refueling procedure.		
4	Operation of controls (machine not running).		
5	Safety controls, clutch operation.		
6	Emergency stop procedures.		
7	Startup of machine.		
8	Maneuvering.		
9	Pitching.		
10	Concrete finishing techniques.		
11	Shutdown of machine.		
12	Lifting of machine.		
13	Machine transport and storage.		

Operator \_\_\_\_\_ Trainee \_\_\_\_\_

COMMENTS:

# CA4-4HMTROWEL— DAILY PRE-OPERATION CHECKLIST

## DAILY PRE-OPERATION CHECKLIST

DAILY PRE-OPERATION CHECKLIST		✓	✓	✓	✓	✓	✓
1	Engine Oil Level.						
2	Gearbox Fluid Level.						
3	Condition of Blades.						
4	Blade Pitch Operation.						
5	Clutch Operation.						

COMMENTS:

# CA4-4HM TROWEL— SAFETY MESSAGE ALERT SYMBOLS

## FOR YOUR SAFETY AND THE SAFETY OF OTHERS!

Safety precautions should be followed at all times when operating this equipment. Failure to read and understand and comply with the Safety Messages and Operating Instructions could result in injury to yourself and others.

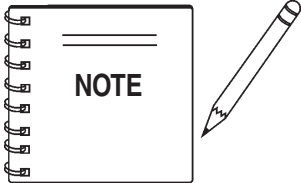

This Owner's Manual has been developed to provide complete instructions for the safe and efficient operation of the MQ Whiteman CA4-4HM TROWEL. For engine maintenance information, please refer to the engine manufacturer's instructions for data relative to its safe operation.

**Before using this WALK-BEHIND TROWEL, ensure that the operating individual has read, understands, and complies with all instructions in this manual.**

## SAFETY MESSAGE ALERT SYMBOLS

The three (3) Safety Messages shown below will inform you about potential hazards that could injure you or others. The Safety Messages specifically address the level of exposure to the operator, and are preceded by one of three words: **DANGER**, **WARNING**, or **CAUTION**.

### **DANGER**

You **WILL** be **KILLED** or **SERIOUSLY INJURED** if you **DO NOT** follow these directions.

### **WARNING**

You **CAN** be **KILLED** or **SERIOUSLY INJURED** if you **DO NOT** follow these directions.

### **CAUTION**

You **CAN** be **INJURED** if you **DO NOT** follow these directions.

Potential hazards associated with trowel operation will be referenced with Hazard Symbols which appear throughout this manual, and will be referenced in conjunction with Safety Message Alert Symbols.

## HAZARD SYMBOLS



### Lethal Exhaust Gases



Engine exhaust gases contain poisonous carbon monoxide. This gas is colorless and odorless, and can cause death if inhaled. **NEVER** operate this equipment in a confined area or enclosed structure that does not provide ample free flow air.



### Explosive Fuel

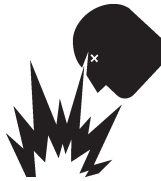

Gasoline is extremely flammable, and its vapors can cause an explosion if ignited. **DO NOT** start the engine near spilled fuel or combustible fluids. **DO NOT** fill the fuel tank while the engine is running or hot. **DO NOT** overfill tank, since spilled fuel could ignite if it comes into contact with hot engine parts or sparks from the ignition system. Store fuel in approved containers, in well-ventilated areas and away from sparks and flames. **NEVER** use fuel as a cleaning agent.



### Burn Hazards



Engine components can generate extreme heat. To prevent burns, **DO NOT** touch these areas while the engine is running or immediately after operations. **NEVER** operate the engine with heat shields or heat guards removed.



### Rotating Parts



**NEVER** operate equipment with covers, or guards removed. Keep **fingers, hands, hair** and **clothing** away from all moving parts to prevent injury.

# CA4-4HM TROWEL— SAFETY MESSAGE ALERT SYMBOLS



## Accidental Starting



**ALWAYS** place the engine **ON/OFF** switch in the **OFF** position, when the trowel is not in use.



## Respiratory Hazard



**ALWAYS** wear approved respiratory protection.



## Over Speed Conditions



**NEVER** tamper with the factory settings of the engine governor or settings. Personal injury and damage to the engine or equipment can result if operating in speed ranges above maximum allowable.



## Sight and Hearing hazard

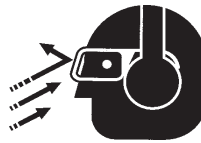

**ALWAYS** wear approved eye and hearing protection.



## Equipment Damage Messages

Other important messages are provided throughout this manual to help prevent damage to your trowel, other property, or the surrounding environment.



## CAUTION

This walk-behind trowel, other property, or the surrounding environment could be damaged if you do not follow instructions.

# CA4-4HM TROWEL — RULES FOR SAFE OPERATION

## RULES FOR SAFE OPERATION

### **WARNING**

Failure to follow instructions in this manual may lead to serious injury or even death! This equipment is to be operated by trained and qualified personnel only! This equipment is for industrial use only.

The following safety guidelines should always be used when operating the CA4-4HM.

### SAFETY

- **DO NOT** operate or service this equipment before reading this entire manual. The manual must be kept available and accessible to the operator. 
- This equipment should not be operated by persons under the minimum statutory age limit.
- **NEVER** use this machine for any purpose other than those described in this manual.
- **NEVER** operate the trowel without proper protective clothing, shatterproof glasses, steel-toed boots and other protective devices required for the job.





- **NEVER** use accessories or attachments which are not recommended by Multiquip for this equipment. Damage to the equipment and/or injury to user may result.
- Manufacturer does not assume responsibility for any accident due to equipment modifications. Unauthorized equipment modification will void all warranties. Any modification which could lead to a change in the original characteristics of the machine should be made only by the manufacturer who shall confirm that the machine is in conformity with appropriate safety regulations.

- **NEVER** operate this equipment when not feeling well due to fatigue, illness or taking medicine.
- **NEVER** operate the trowel under the influence of drugs or alcohol.
- Replace nameplate, operation and safety decals when they become difficult to read.
- **ALWAYS** check the trowel for loosened hardware such as nuts and bolts before starting.
- **NEVER** touch the hot exhaust manifold, muffler or cylinder. Allow these parts to cool before servicing the trowel. 

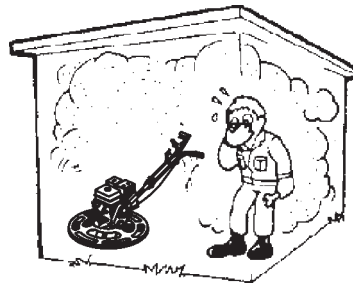
- **High Temperatures** – Allow the engine to cool before adding fuel or performing service and maintenance functions. Contact with **hot!** components can cause serious burns.
- The engine of this trowel requires an adequate free flow of cooling air. **NEVER** operate the trowel in any enclosed or narrow area where free flow of the air is restricted. If the air flow is restricted it will cause serious damage to the engine and may cause injury to people. Remember the engine gives off **DEADLY** carbon monoxide gas.

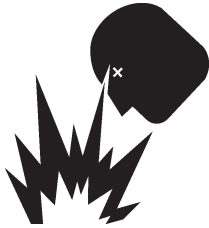

- **ALWAYS** refuel in a well-ventilated area, away from sparks and open flames.
- **ALWAYS** use extreme caution when working with **flammable** liquids. When refueling, **STOP** the engine and allow it to cool.
- **NEVER** operate the trowel in an explosive atmosphere where fumes are present, or near combustible materials. An explosion or fire could result in severe **bodily harm or even death**. 

- **NEVER** **smoke** around or near the machine. Fire or explosion could result from **fuel vapors**, or if fuel is spilled on a **hot!** engine. 
- Topping-off to filler port is dangerous, as it tends to spill fuel.
- **NEVER** use fuel as a cleaning agent.

# CA4-4HM TROWEL — RULES FOR SAFE OPERATION

- **NEVER** Run engine without air filter. Severe engine damage may occur. Service air filter frequently to prevent carburetor malfunction.
- **NEVER** place your **feet** or **hands** inside the guard rings while starting or operating this equipment.
- **AVOID** wearing jewelry or loose fitting clothing that may snag on the controls or moving parts as this can cause a serious injury.
- **ALWAYS** keep clear of **rotating** or **moving parts** while operating the trowel.
- **Moving Parts** – Shut down the engine before performing service or maintenance functions. Contact with moving parts can cause serious injury.
- **ALWAYS** check to make sure that the operating area is clear before starting the engine.
- **NEVER** leave the machine **unattended** while running.
- **ALWAYS** be sure the operator is familiar with proper safety precautions and operations techniques before using trowel.
- **ALWAYS** keep the work area well organized.
- **ALWAYS** clear the work area of any debris, tools, etc. that would constitute a hazard while the trowel is in operation.

## **WARNING**

**ALWAYS** check to make sure that the operating area is clear before starting the engine.

- No one other than the operator is to be in the working area when the trowel is in operation.
- Always observe all applicable compulsory regulations relevant to environmental protection, especially, fuel storage, the handling of hazardous substances, and the wearing of protective clothing and equipment. Instruct the user as necessary, or, as the user, request this information and training.
- **ALWAYS** store equipment properly when it is not being used. Equipment should be stored in a clean, dry location out of the reach of children.

## Transporting

- **ALWAYS** shutdown engine before transporting.
- Tighten fuel tank cap securely and close fuel cock to prevent fuel from spilling.
- Drain fuel when transporting trowel over long distances or bad roads.

- When placing the trowel inside a truck-bed for transport, always tie-down the trowel.
- **ALWAYS** use proper lifting techniques when moving the trowel.

## Maintenance Safety

- **NEVER** lubricate components or attempt service on a running trowel.
- **ALWAYS** allow the trowel a proper amount of time to cool before servicing.
- Keep the trowel in proper running condition.
- Fix damage to the trowel immediately and always replace broken parts.
- Dispose of hazardous waste properly. Examples of potentially hazardous waste are used motor oil, fuel and fuel filters.
- **DO NOT** use food or plastic containers to dispose of hazardous waste.

## Emergencies

- **ALWAYS** know the location of the nearest **fire extinguisher**.



- **ALWAYS** know the location of the nearest **first aid kit**.



- In emergencies **always** know the location of the nearest phone or **keep a phone on the job site**. Also know the phone numbers of the nearest **ambulance, doctor** and **fire department**. This information is invaluable in the case of an emergency and could keep a serious situation from becoming a tragic one.



# CA4-4HM TROWEL— OPERATION AND SAFETY DECALS

## OPERATION AND SAFETY DECALS

The CA4-4HM walk-behind trowel is equipped with a number of operation, safety and maintenance decals. Should any of these decals become unreadable, replacements can be obtained from your dealer.



P/N 1848



P/N 20936



CONTACT  
SERVICE  
DEPARTMENT



P/N: 13118



P/N 11092



P/N 36099 (ISO Blue)



P/N: 21455



P/N 35168

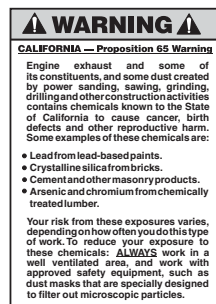

P/N 20525



P/N 2942 WHITE TEXT 13"

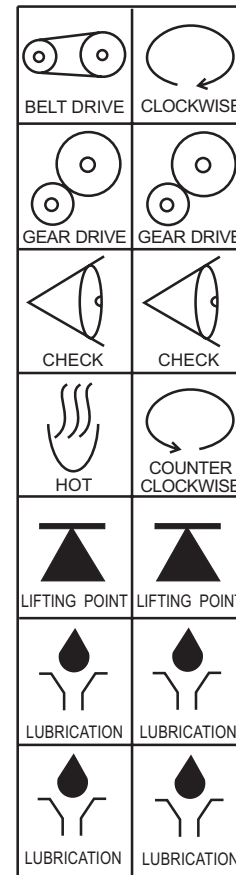

P/N: 11246

**ATTENTION**

PUSH PITCH CONTROL TO FULL FORWARD POSITION BEFORE FOLDING HANDLE

P/N 10732 (WHITE TEXT)

# CA4-4HM TROWEL— GENERAL INFORMATION

## Intended Use

Operate the CA4-4HM Trowel, tools and components in accordance with the manufacturer's instructions. Use of any other tools for stated operation is considered contrary to designated use. The risk of such use lies entirely with the user. The manufacturer cannot be held liable for damages as a result of misuse.

## CA4-4HM Trowel Familiarization

This walk-behind trowel is designed for the **floating** and **finishing** of concrete slabs.

Take a walk around the trowel. Take notice of all the major components (see Figure 2) like the engine, blades, Quick Pitch™ handle, clutch lever, etc. Check that there is always oil in the engine.

**Read** all the safety instructions carefully. Safety instructions will be found throughout this manual and on the trowel. Keep all safety information in good, readable condition. Operators should be well trained on the operation and maintenance of the trowel.

Before using your trowel, test it on a flat watered down section of finished concrete that is free of any debris and other objects.

This trial test run will increase your confidence in using the trowel and at the same time it will familiarize you with the trowel's controls. In addition you will understand how the trowel handles under actual conditions.

## Engine

This trowel is available with an 4 HP **HONDA** gasoline engine. Refer to the engine owner's manual for instructions regarding the operation and maintenance of your engine. Please contact your nearest Multiquip Dealer for a replacement should the original manual disappear or otherwise become unusable.

## Drive System

Power is transferred from the engine to the gearbox input shaft via a V-belt pulley drive system. The pulley engages using a manual clutch. See Parts section of this manual.

## Gearbox

The **gearbox** is located beneath the engine and transfers power to the **spider** assembly. The gearbox controls the rotational speed of the trowel and is equipped with two shafts (input and output).

## Spider

The vertical output shaft of the gearbox connects to a cast hub called the **spider**. The spider has 4 arms that extend outward that are used for attachment of blades or other accessories. Remember as the gearbox output shaft rotates so does the spider assembly.

## Guard Ring

This unit is equipped with a special rotating guard ring. It is designed to allow the operator to run the machine alongside walls, pipes, and obstructions without marring the surface.

## Blades

The blades of the trowel finish the concrete as they are rotated around the surface. This trowel comes equipped with four **combination** (8 in./203mm wide) **blades** per rotor equally spaced in a radial pattern and attached to vertical rotating shaft by means of a **spider assembly**.

## Manual Clutch

In the event of a trowel runaway condition (operator releases the handle), a **manual clutch** will stop the engine and bring the trowel to a halt.

## CAUTION

**NEVER** attempt to **lift** the trowel by yourself. **ALWAYS** get the assistance of another person to help lift the trowel .

## Training

For proper training, please use the "**TRAINING CHECKLIST**" located in the front of this manual (Page 8). This checklist will provide an outline for an experienced operator to provide training to a new operator

# CA4-4HMTROWEL— CONTROLS AND COMPONENTS

Figure 2. Controls and Components

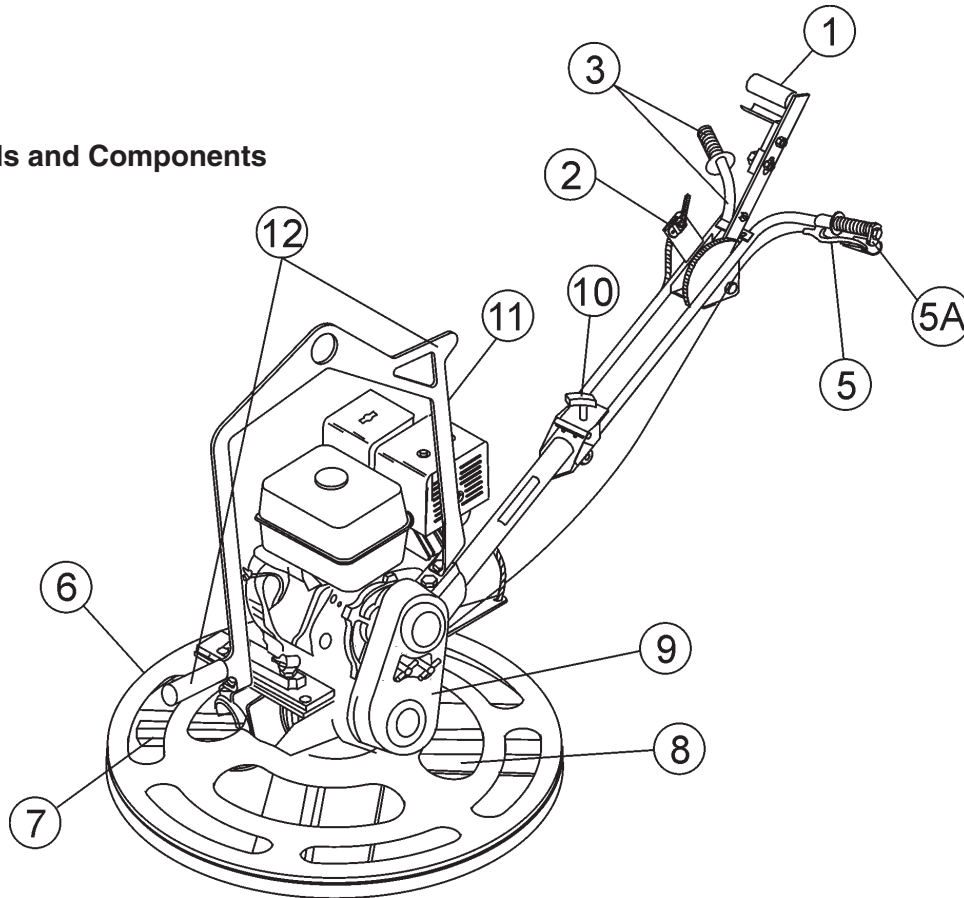

Figure 2 shows the location of the basic controls or components, for the **CA4-4HMTROWEL**. Listed below is a brief explanation of each control or component

- 1. Quick Pitch™ Control Handle** – To adjust the pitch of the blades, grasp the handle then squeeze and either move the handle forward or backward to achieve the desired blade pitch.
- 2. Throttle Control Lever** – Controls the speed of the engine. Move the hand lever towards the operator to increase engine speed (high), away from the operator to decrease engine speed (low).
- 3. Hand Grip/Handle Bar** – When operating the trowel, place both hands on each grip to maneuver the trowel. Replace hand grips when they become worn or damaged.
- 4. Engine** – This trowel uses a Honda GX120 4 H.P. gasoline engine.
- 5. Clutch Lever** - Clutch engagement lever. When this lever is engaged, the blades will begin to rotate.
- 5A. Clutch Lever Retainer**- Assists the operator in holding down the clutch lever.
- 6. Rotating Guard Ring**- **NEVER** put hands or feet inside guard ring. **NEVER** attempt to lift trowel by the guard ring.
- 7. Trowel Arm** – **NEVER** operate the trowel with a bent, broken or out of adjustment trowel arm. If the blades show uneven wear patterns or some blades wear out faster than others, the trowel arm may need to be replaced.
- 8. Blades** – This trowel is equipped with special combination blades. Designed specifically for edging. In addition float discs can be attached to the trowel arms that will allow the trowel to float on "**wet**" concrete.
- 9. V-Belt Cover** – Remove this cover to gain access to the V-belt. **NEVER** operate the trowel with this cover removed.
- 10. T-Handle Release Knob** – Turn this handle counter-clockwise to release the upper handle and place in either down position or operate position. Turn handle clockwise to lock upper handle in place.
- 11. Lifting Bale** – Trowel can be lifted and moved either by crane or by two people using the two handles on the bale.
- 12. Lifting Handle** – For use when two people are lifting the trowel. Always make sure the folding handle is secure when lifting. Never attempt to lift the trowel by the guard ring.

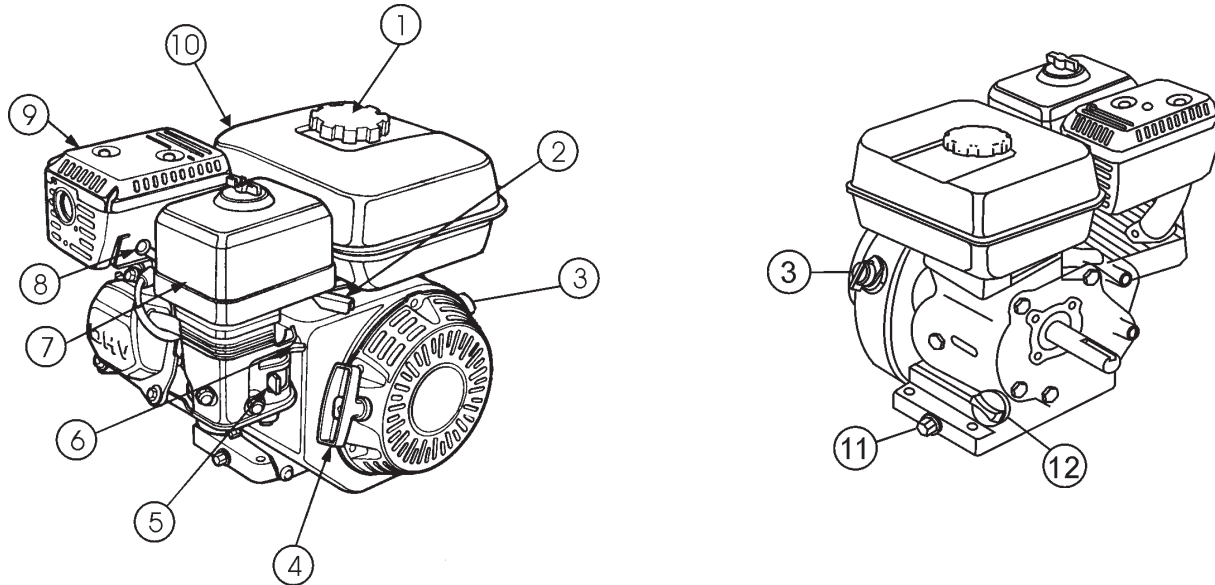

Figure 3. Honda GX120K1QX2 Engine Controls and Components

## INITIAL SERVICING

The engine (Figure 3) must be checked for proper lubrication and filled with fuel prior to operation. Refer to the manufacturer's engine manual for instructions & details of operation and servicing. The engine shown above is a **HONDA** engine, operation for other types of engines may vary somewhat.

1. **Fuel Filler Cap** – Remove this cap to add unleaded gasoline to the fuel tank. Make sure cap is tightened securely. **DO NOT** over fill.

### DANGER

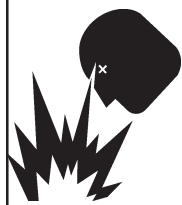

Adding fuel to the tank should be done only when the engine is stopped and has had an opportunity to cool down. In the event of a fuel spill, **DO NOT** attempt to start the engine until the fuel residue has been completely wiped up, and the area surrounding the engine is dry.

2. **Throttle Lever** – Used to adjust engine RPM speed (lever advanced forward **SLOW**, lever back toward operator **FAST**).
3. **Engine ON/OFF Switch** – **ON** position permits engine starting, **OFF** position stops engine operation.
4. **Recoil Starter (pull rope)** – Manual-starting method. Pull the starter grip until resistance is felt, then pull briskly and smoothly.

5. **Fuel Valve Lever** – **OPEN** to let fuel flow, **CLOSE** to stop the flow of fuel.
6. **Choke Lever** – Used in the starting of a cold engine, or in cold weather conditions. The choke enriches the fuel mixture.
7. **Air Cleaner** – Prevents dirt and other debris from entering the fuel system. Remove wing-nut on top of air filter canister to gain access to filter element.

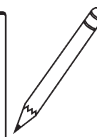
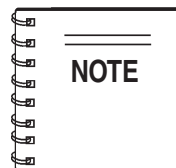

Operating the engine without an air filter, with a damaged air filter, or a filter in need of replacement will allow dirt to enter the engine, causing rapid engine wear.

8. **Spark Plug** – Provides spark to the ignition system. Set spark plug gap according to engine manufacturer's instructions. Clean spark plug once a week.
9. **Muffler** – Used to reduce noise and emissions.
10. **Fuel Tank** – Holds unleaded gasoline. For additional information refer to engine owner's manual.
11. **Oil Drain Plug** – Remove this plug to remove oil from the engine's crankcase.
12. **Dipstick/Oil Filler Cap** – Remove this cap to determine if the engine oil is low. Add oil through this filler port as recommended in Table 3.

# CA4-4HM TROWEL — ASSEMBLY

## Quick Pitch™ Handle Assembly

The CA4-4HM TROWEL is equipped with a folding upper handle (Figure 4). It was assembled at the factory and shipped in its folded or stow position. You will need to unfold and adjust the trowel handle to the upright position prior to operation.

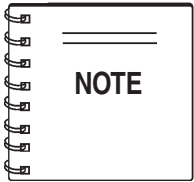

Considerable force may be required when moving the **Quick Pitch™ handle** forward or backward.

## Unfolding the Trowel for Operation

1. Make sure that the **Quick Pitch™ handle** has been attached to the upper handle bar and the pitch control cable has slack. Remove the **T-handle knob** from the swing bolt on the top side of the upper handle bar, by rotating the knob counter-clockwise. Move the **Quick Pitch™ handle** toward's the operator's position and unfold the upper handle bar away from the engine into the **upright** position. Re-insert the swing bolt so that it fits through the slot in the hinge plate. Turn the T-handle knob counter-clockwise securely to hold upper handle bar in place.

## CAUTION

**DO NOT** operate unless T-Handle Knob is securely in place.

2. When folding the handle assembly, remember to move the **Quick Pitch™ handle** forward first to avoid stretching the throttle cable.

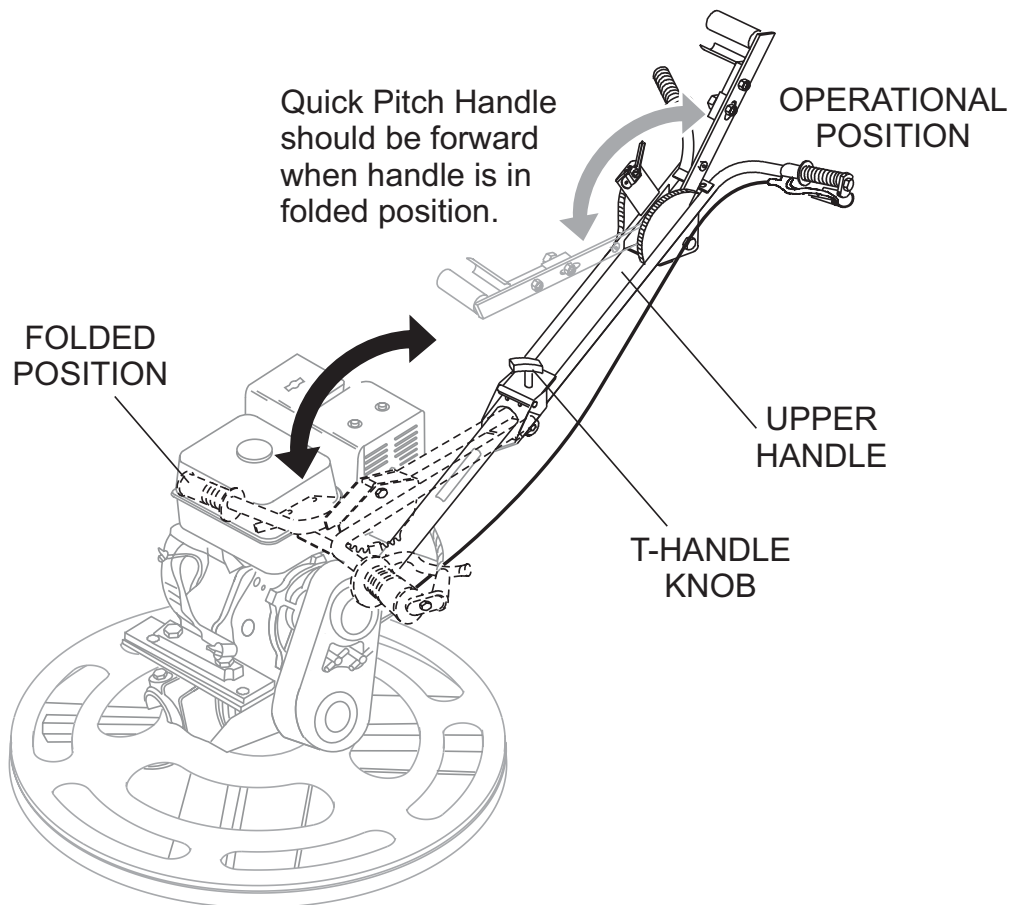
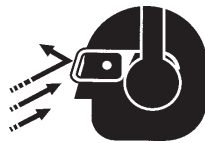

Figure 4. Trowel Folded and Operational Positions

## CAUTION

**ALWAYS** wear approved eye and hearing protection before operating the trowel.



**NEVER** place hands or feet inside the guard rings while the engine is running. **ALWAYS** shut the engine down before performing any kind of maintenance service on the trowel.



### Before Starting

1. Read safety instructions at the beginning of manual.
2. Clean the trowel, removing dirt and dust, particularly the engine cooling air inlet, carburetor and air cleaner.
3. Check the air filter for dirt and dust. If air filter is dirty, replace air filter with a new one as required.
4. Check carburetor for external dirt and dust. Clean with dry compressed air.
5. Check fastening nuts and bolts for tightness.

### Engine Oil Check

1. To check the engine oil level, place the trowel on secure level ground with the engine stopped.
2. Remove the filler dipstick from the engine oil filler hole (Figure 5) and wipe clean.

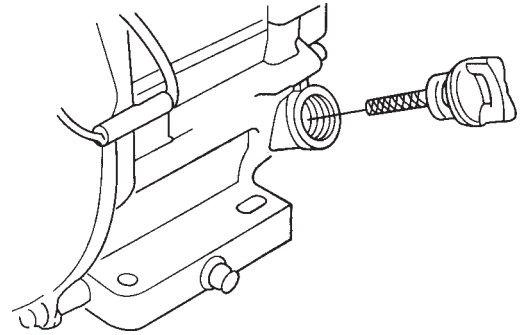
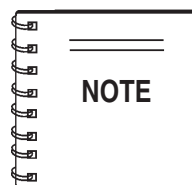

Figure 5. Engine Oil Dipstick (Removal)

3. Insert and remove the dipstick without screwing it into the filler neck. Check the oil level shown on the dipstick.
4. If the oil level is low (Figure 6), fill to the edge of the oil filler hole with the recommended oil type (Table 3). Maximum oil capacity is 0.48 quarts (.45 liters).



Reference manufacturer engine manual for specific servicing instructions.

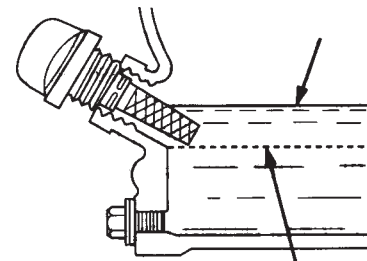

Figure 6. Engine Oil Dipstick (Oil Level)

Table 4. Oil Type

Season	Temperature	Oil Type
Summer	25°C or Higher	SAE 10W-30
Spring/Fall	25°C~10°C	SAE 10W-30/20
Winter	0°C or Lower	SAE 10W-10

## **!** DANGER

### **EXPLOSIVE FUEL!**

Motor fuels are highly flammable and can be dangerous if mishandled. **DO NOT** smoke while refueling. **DO NOT** attempt to refuel the trowel if the engine is *hot!* or *running.*



### Fuel Check

1. Remove the gasoline cap located on top of fuel tank.
2. Visually inspect to see if fuel level is low. If fuel is low, replenish with unleaded fuel.
3. When refueling, be sure to use a strainer for filtration. **DO NOT** top-off fuel. Wipe up any spilled fuel.

### Gearbox Oil

1. Determine if the **gearbox** oil is low by removing the oil plug located on the side of the gearbox. This plug will be marked by the "**check**" decal. See Figure 7. The correct level of the lubrication oil should be to the bottom of the fill plug.

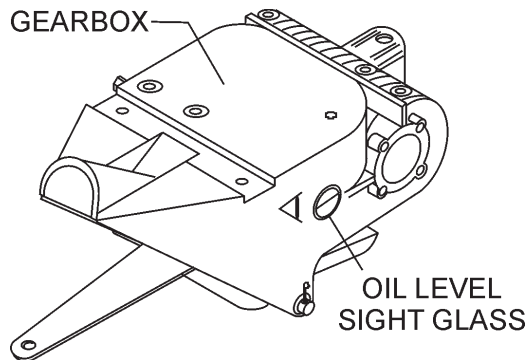

**Figure 7. Gearbox**

2. If lubrication oil begins to seep out as the drain plug is being removed, then it can be assumed that the gearbox has a sufficient amount of oil.
3. If lubrication oil does not seep out as the drain plug is being removed, fill with **type ISO 680 (P/N 10139)** gearbox lubricant oil until the oil filler hole overflows.

## **!** CAUTION

Disconnect the spark plug wire from the spark plug and secure away from the engine before performing maintenance or adjustments on the machine.

### V-Belt Check

A worn or damaged V-belt can adversely affect the performance of the trowel. If a V-belt is defective or worn simply replace the V-belt as outlined in the maintenance section of this manual.

### Belt Guard Check

Check for damage, loose or missing hardware.

### Blade Check

Check for worn or damaged blades. Check to see if one blade is worn out while the others look new. If this is the case there could be a blade pitch problem. Refer to the maintenance section of this manual for blade pitch adjustment procedure. Replace any worn blades.

### Hand Clutch

This finisher model is equipped with a **hand operated clutch**. The unit automatically stops rotating when the clutch lever is released. Clutch operation should be tested each time the machine is started.

**DO NOT** let the machine sit unused with the engine at high speed for an extended period of time. It will cause premature belt wear or may destroy the belt. Always set the engine speed to idle when the hand clutch is disengaged.

## **!** WARNING

**NEVER** attempt to override the manual clutch by using tape or other means to hold down the clutch lever. Doing so may cause **SEVERE INJURY.**

# CA4-4HM TROWEL — INITIAL START-UP

This section is intended to assist the operator with the initial start-up of the walk-behind trowel. It is extremely important that this section be read carefully before attempting to use the trowel in the field.

**DO NOT** use your trowel until this section is thoroughly understood

## Lifting the Trowel Onto a Slab

Extra care should be taken when lifting the trowel off the ground. Serious damage to the machine or personal injury could be caused by dropping a trowel.

### **WARNING**

**NEVER** attempt to lift this machine alone. **NEVER** lift the trowel by the guard ring as it may rotate and cause injury.

**ALWAYS** make certain the folding handle is secure and use only the manufacturer's approved lifting points. The trowel may be lifted at the center lifting bale by crane or other lifting device of adequate capacity.

### **CAUTION**

**DO NOT** attempt to operate the trowel until the Safety, General Information and Inspection sections of this manual have been read and thoroughly understood.

## Starting the Engine

1. Place the engine **fuel valve lever** (Figure 8) to the "ON" position.

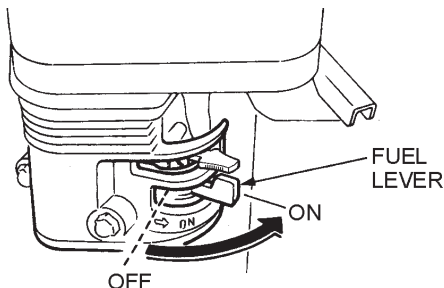

Figure 8. Engine Fuel Valve Lever

2. Place the trowel's **throttle lever** (Figure 9) to the "IDLE" position.

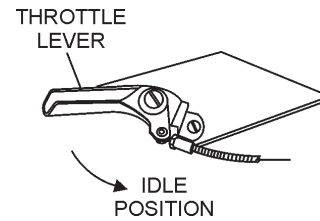

Figure 9. Throttle Lever (Idle Position)

3. Place the **choke lever** (Figure 10) in the "CLOSED" position if starting a **cold engine**.

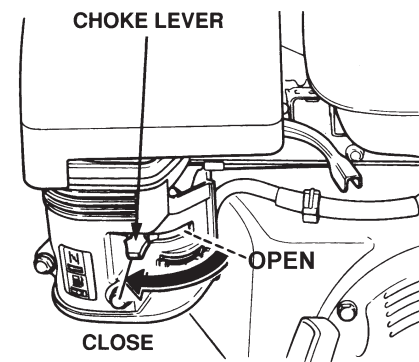

Figure 10. Engine Choke Lever

4. Place the **choke lever** (Figure 11) in the "OPEN" position if starting a **warm engine** or the **temperature is warm**.

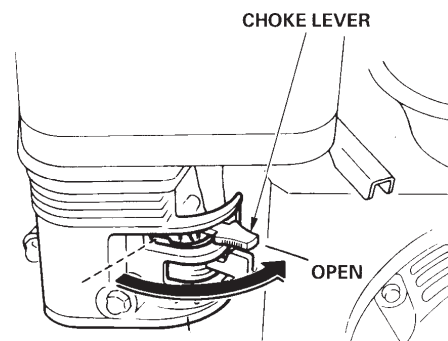

Figure 11. Engine Choke Lever (Open)

5. Place the **engine ON/OFF switch** (Figure 12) in the "ON" position.

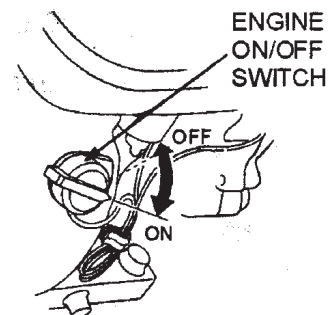

Figure 12. Engine ON/OFF Switch

## CA4-4HM TROWEL — INITIAL START-UP

6. Grasp the starter grip (Figure 13) and slowly pull it out. The resistance becomes the hardest at a certain position, corresponding to the compression point. Pull the starter grip briskly and smoothly for starting.

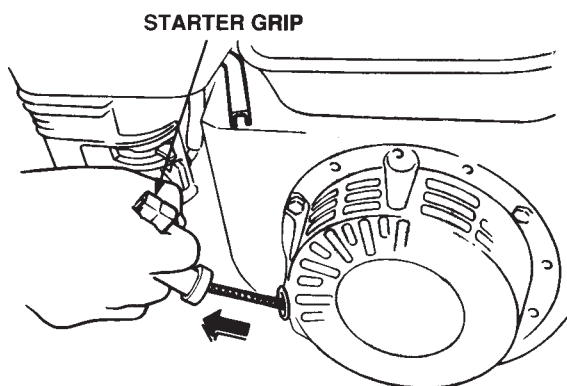

Figure 13. Starter Grip

7. If the engine has started, slowly return the choke lever (Figure 11) to the **OPEN** position. If the engine has not started repeat steps 1 through 6.
8. Before the trowel is placed into operation, run the engine for several minutes. Check for fuel leaks, and noises that would associate with a loose V-belt cover or component.
9. To begin troweling, move the throttle lever (Figure 14) toward the "**FAST**" position.

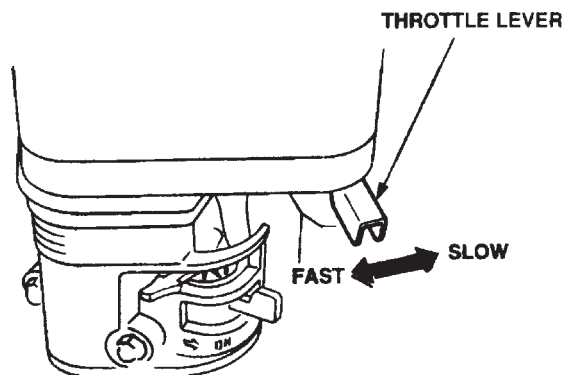

Figure 14. Throttle Lever (Run Position)

### Stopping The Engine

1. Move the throttle lever to the **IDLE** or **SLOW** position (Figure 14) and run the engine for three minutes at low speed.

2. After the engine **cools**, turn the engine start/stop switch to the "**OFF**" position (Figure 15).

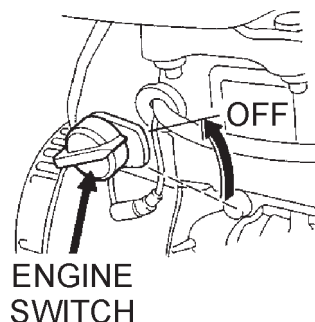

Figure 15. Engine ON/OFF Switch (OFF Position)

3. Close the **fuel shut-off valve** (Figure 16) by moving the fuel valve lever to the **OFF** position.

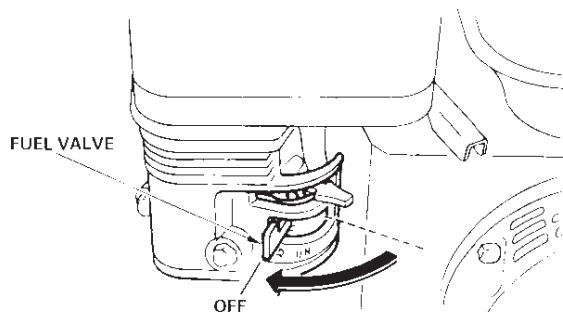

Figure 16. Fuel Valve Lever (OFF Position)

## CA4-4HM TROWEL — OPERATION

The following steps are intended as a basic guide to machine operation, and are not to be considered a complete guide to concrete finishing. We suggest that all operators (experienced and novice) read “*Slabs on Grade*” published by the **American Concrete Institute, Detroit, Michigan**. Read the “Training” section of this manual for more information.

### Pitching The Blades - Quick Pitch Handle

1. To pitch the blades upwards using the “**Quick Pitch™ handle**,” (Figure 17) simply squeeze the trigger lock and pull the handle towards the operator. Pushing the handle towards the engine will cause the blades to lay flat.

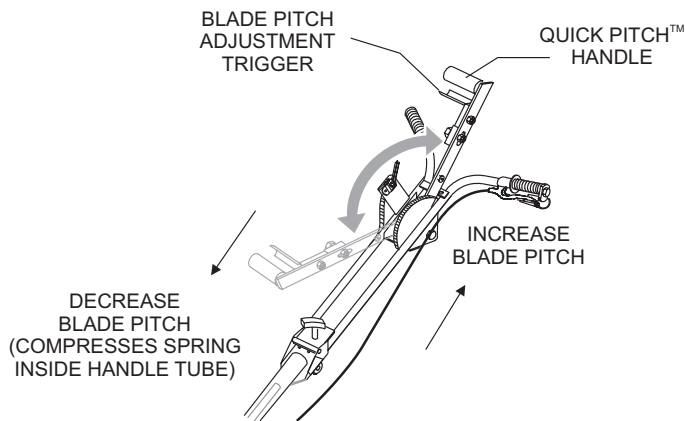

Figure 17. Quick Pitch™ Handle

### Maneuvering the Trowel

1. Get into the operator's position behind the handle. With a secure foothold and a firm grasp on the handles slowly increase the engine speed until the desired blade speed is obtained.

Set engine speed with the throttle, then pull on the hand clutch lever to start the blades turning. Adjust the blade speed after the hand clutch is fully engaged.

2. To maneuver the trowel, gently lift up on or press down on the main trowel handle. To move the machine to the operator's left, **lift up** on the handle, to move machine to the right, **push down** on the handle.

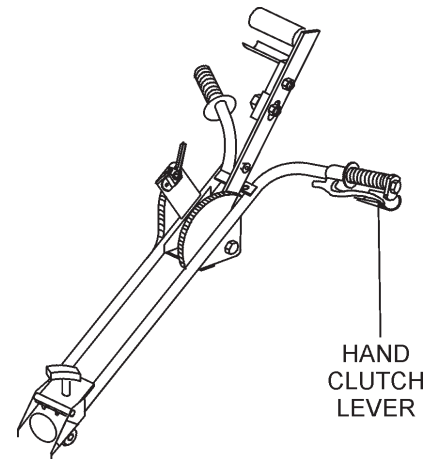

Figure 18. Hand Clutch Lever

3. The best method for finishing concrete is to slowly walk backwards (Figure 19) with the trowel, guiding the trowel from side to side. This will cover all footprints on wet concrete.
4. Remember that if you let go of the trowel, just step away and let the trowel come to a complete stop before trying to recover the trowel.
5. Check the manual clutch occasionally for proper operation. Checking operation of the manual clutch at the beginning of operation and periodically serves as a safety check verification.

## CA4-4HM TROWEL — OPERATION

Figure 19 below illustrates a typical walk-behind trowel application. Practice maneuvering the trowel. The trick is to let the trowel do the work.

Continue to practice maneuvering the trowel. Try to practice as if you were finishing a slab of concrete. Practice edging and covering a large area. Remember a good finishing technique is to work backwards. Be careful when moving backwards so that hazards can be avoided. The best way to get accustomed to the trowel is repeated use.

To move the trowel to the operator's left, **lift up** on the handle, to move the trowel to the right **push down** on the handle.

**Remember!** that if you let go of the trowel, just **step away** and let the trowel come to a complete **STOP** before trying to recover the trowel.

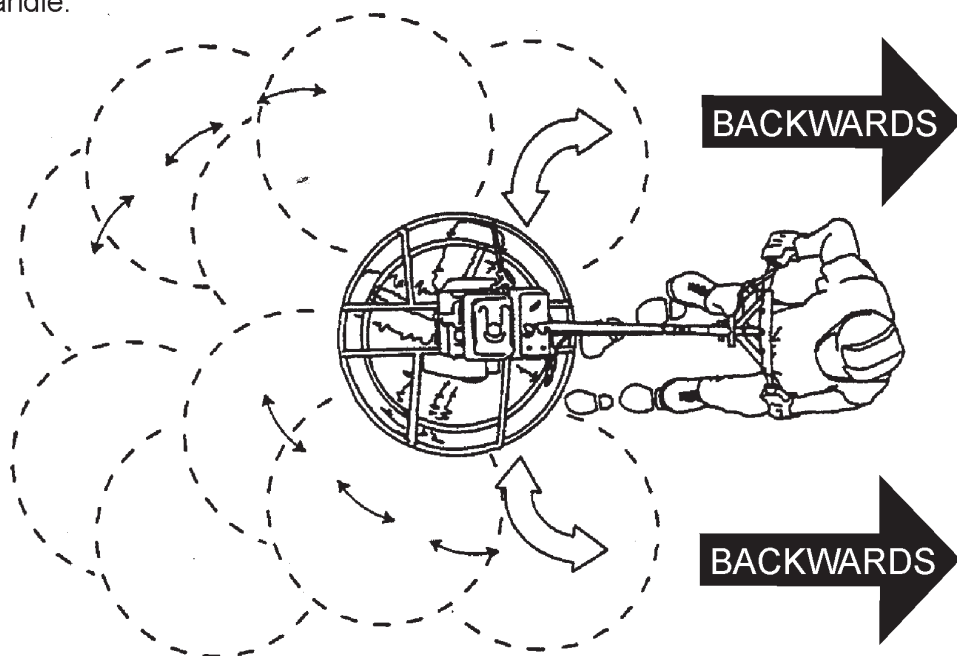

The best method for finishing concrete is to slowly walk **backwards** with the trowel, guiding the trowel from side to side. This will cover all footprints on wet concrete.

Figure 19. Maneuvering The Trowel

### CAUTION

**NEVER** place your **feet** or **hands** inside the guard rings while starting or operating this equipment.

### CAUTION

**ALWAYS** keep clear of **rotating** or **moving** parts while operating this equipment.

## Blades

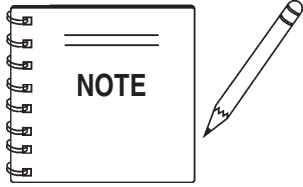

Blades should be changed when they fail to finish concrete in a satisfactory manner.

Blades are a vital part of finishing concrete. This finisher has been designed to finish concrete and is built to stringent quality standards out of the finest trowel steel. If you need replacement blades, consult your parts list in this manual for part numbers and order them from your Multiquip parts dealer or importer.

## Combo Blades

This trowel was equipped with **combination type** (Figure 20) blades as original equipment. These blades have been designed for optimum performance in both the floating and finishing of concrete. These blades are versatile and should take care of most troweling needs.

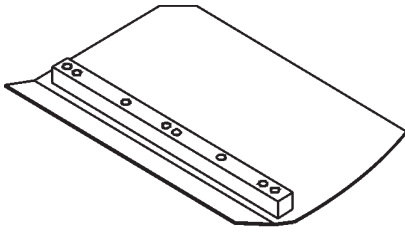

Figure 20. Combination Blade

## Optional Float Discs (Pans)

These round discs (Figure 21) attach to the spiders and allow the machine to “float” on “wet” concrete. The disc design allows early floating and easy movement from wet to dry areas. They are also very effective in embedding large aggregates and surface hardeners.

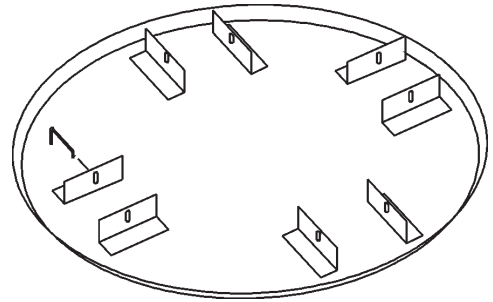
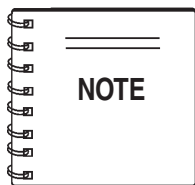

Figure 21. Float Disk (Pan)



# CA4-4HM TROWEL — MAINTENANCE



See the engine manual supplied with your machine for appropriate engine maintenance schedule and troubleshooting guide for problems.

At the front of the book (Page 9) there is a “**Daily Pre-Operation Checklist**”. Make copies of this checklist and use it on a daily basis.

**CAUTION**

**ALWAYS** allow the engine to cool before servicing. **NEVER** attempt any maintenance work on a **hot!** engine.



**CAUTION**

Disconnect the spark plug wire from the spark plug and secure away from the engine before performing maintenance or adjustments on the machine.

## MAINTENANCE SCHEDULE

### Daily (8-10 Hours)

1. Check the oil level in the engine crankcase and gear box, fill as necessary.
2. Check V-belt.

### Weekly (50-60 Hours)

1. Relube arms, thrust collar and clutch
2. Replace blades if necessary.
3. Check and clean or replace the engine air filter as necessary.
4. Replace engine oil and filter as necessary, see engine manual.

### Monthly (200-300 Hours)

1. Remove, clean, reinstall and relube the arms and thrust collar. Adjust the blade arms.
2. Remove, clean, reinstall clutch.

### Yearly (2000-2500 Hours)

1. Check and replace if necessary the arm bushings, thrust collar bushings and shaft seals.
2. Check pitch control cables for wear.
3. Adjust blade speed.

## Trowel Arm Adjustment Procedure

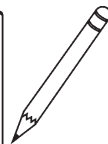
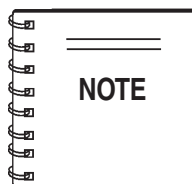

The following procedure should be followed to adjust trowel arms when it becomes apparent that the trowel is finishing poorly or in need of routine maintenance.

A **level**, clean area to test the trowel prior to and after is essential. Any unlevel **spots** in the floor or debris under the trowel blades will give an incorrect perception of adjustment. Ideally, a 5" x 5" (127mm x 127mm), 0.75 inch (19 mm) thick **flat** steel plate should be used for testing.

1. To determine which blades need adjustment, place the trowel in the test area (0.75 inch [19 mm] thick plate) and look for the following conditions:
  - Pitch the blades as flat as possible and look at the **adjustment bolts**. They should all just make contact with the **lower wear plate** on the spider. If you can see that one of them is not making contact, some adjustment will be necessary.
  - Is the machine wearing out blades unevenly (i.e. one blade is completely worn out while the others look new)?

Figure 22 below illustrates “**worn spider or bent trowel arms**”. Check to see that adjustment bolt is barely touching (0.10" max. clearance) lower wear plate. All alignment bolts should be spaced the same distance from the lower wear plate.

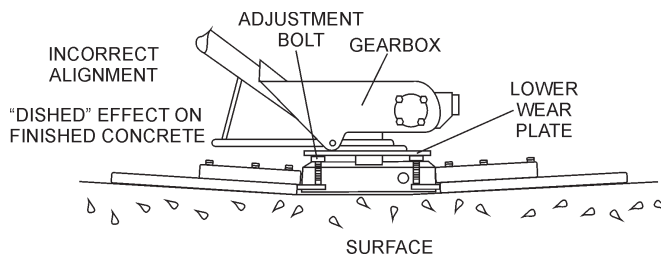

Figure 22 Worn Spider Plate

Figure 23 below illustrates the “**correct alignment**” for a spider plate (as shipped from the factory).

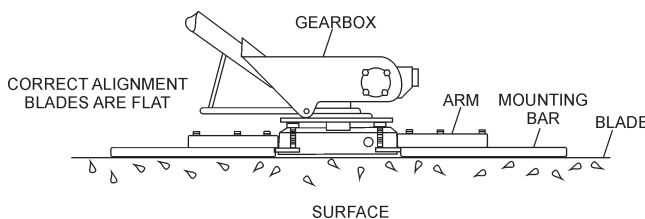

Figure 23. Correct Spider Plate Alignment

# CA4-4HM TROWEL — MAINTENANCE

2. Start engine, and bring trowel blades up to full speed and look for the following conditions:
  - Does the trowel have a perceived rolling or bouncing motion when in use?
  - Look at the trowel while it is running, does the guard ring “rock up and down” relative to the ground?

## Spider Removal

1. Once it is determined that an adjustment is required, remove the spider assembly from the gearbox shaft as follows:
  - a. Remove the zerk fitting and allen head screw designated by the letter “S” (Figure 24). In addition, on the opposite side of the spider block there is another zerk fitting and allen head screw, remove both of these components.

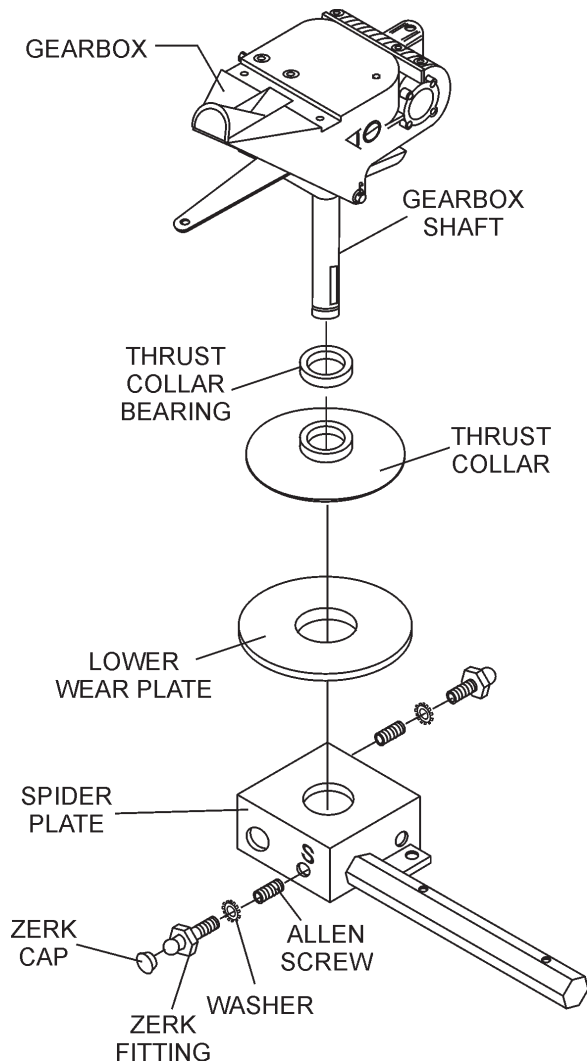

Figure 24. Spider/Gearbox Removal

- b. Lift the upper trowel assembly off the spider assembly. A slight tap with a rubber mallet may be necessary to dislodge the spider from the main shaft of the gearbox.

## Trowel Arm Removal

1. Remove the two remaining zerk fittings and allen head screws from the spider assembly (Figure 25).

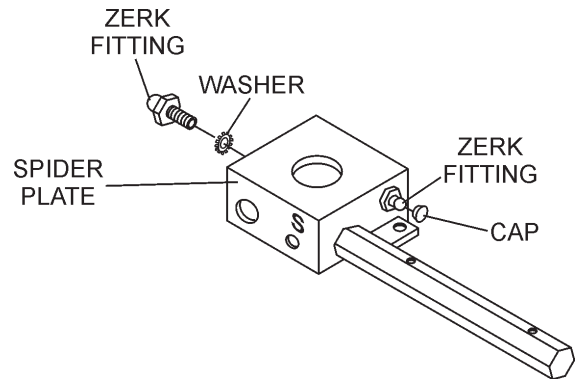

Figure 25. Trowel Arms Removal

## Trowel Blade Removal

**CAUTION**

Disconnect the spark plug wire from the spark plug and secure away from the engine before performing maintenance or adjustments on the machine.

1. Remove the trowel blades from the trowel arm by removing the two hex head bolts (Figure 26) from the trowel arm. Set blades aside.

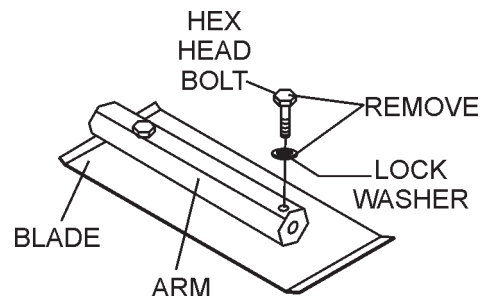

Figure 26. Trowel Blades

2. **Wire brush** any build-up of concrete from all six sides of the trowel arm. Repeat this for the remaining three arms.

# CA4-4HM TROWEL — MAINTENANCE

## Checking Trowel Arm Straightness

Trowel arms can be damaged by rough handling, (such as dropping the trowel on the pad), or by striking exposed plumbing, forms, or rebar while in operation. A bent trowel arm will not allow the trowel to operate in a smooth fluid rotation. If bent trowel arms are suspect, check for flatness as follows, refer to Figures 27 and 28:

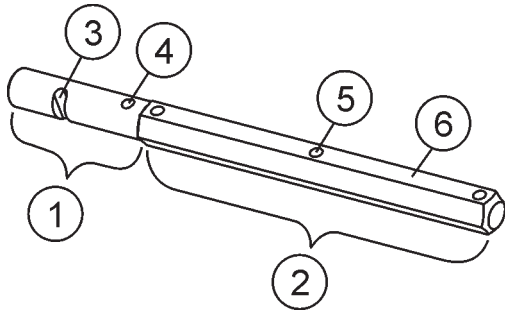

- 1 Trowel Arm Round Shaft Section
- 2 Trowel Arm Hexagonal (Hex) Shaft Section
- 3 Lever Mounting Slot (Left Arm Shown)
- 4 Roll Pin Hole
- 5 Blade Attachment Bolt Hole (One of Three)
- 6 Flat of Hexagonal Shaft (Top of Arm)

**Figure 27. Trowel Arm**

1. Use a thick steel plate, granite slab or any surface which is **true** and **flat**, to check all **six sides** of each trowel arm for flatness.
2. Check each of the six sides of the trowel arm (hex section). A feeler gauge of .004" (0.10 mm) should not pass between the flat of the trowel arm and the test surface along its length on the test surface. (Figure 28 item 3).

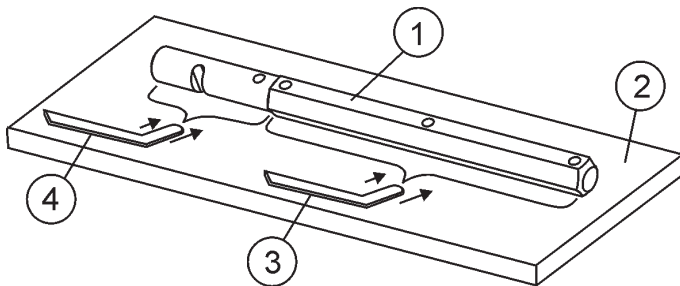

- 1 Trowel Arm
- 2 Flat Test Surface
- 3 Feeler Gauge (.004 in. / 0.10 mm)
- 4 Feeler Gauge (.005 in. / 0.127 mm)

**Figure 28. Checking Trowel Arm Flatness**

3. Next, check the clearance between the round shaft and the test surface as one of the flat hex sections of the arm rests on the test surface. Rotate the arm to each of the flat hex sections and check the clearance of the round shaft. Use a feeler gauge of .005" (0.127 mm). Each section should have the **same clearance** between the round of the trowel arm shaft and the test surface.
4. If the trowel arm is found to be **uneven** or **bent**, replace the trowel arm.

## Trowel Arm Adjustment

Shown in (Figure 31) is the adjustment fixture with a trowel arm inserted. As each trowel arm is locked into the fixture, the arm bolt is adjusted to where it contacts a stop on the fixture. This will consistently adjust all of the trowel arms, keeping the finisher as flat and evenly pitched as possible.

1. Locate the trowel arm adjustment tool P/N 9177.

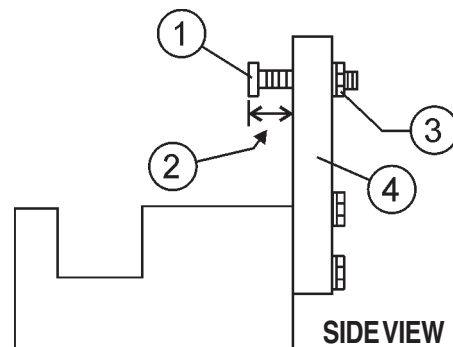

- 1 Adjustment Bolt
- 2 "Distance"
- 3 Locking Nut
- 4 Fixture Arm

**Figure 29. Trowel Arm Adjustment Tool Side View**

2. Ensure the fixture arm is in the proper setting (up or down) for your trowel arm rotation as shown in Figure 30.

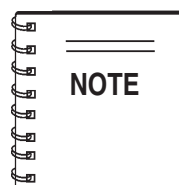

Arms with **CLOCK-WISE** blade rotation use the fixture arm in the **UP** position (A in Figure 30). Arms with **COUNTER CLOCK-WISE** blade rotation use the fixture with the fixture arm in the **DOWN** position. (B in Figure 30).

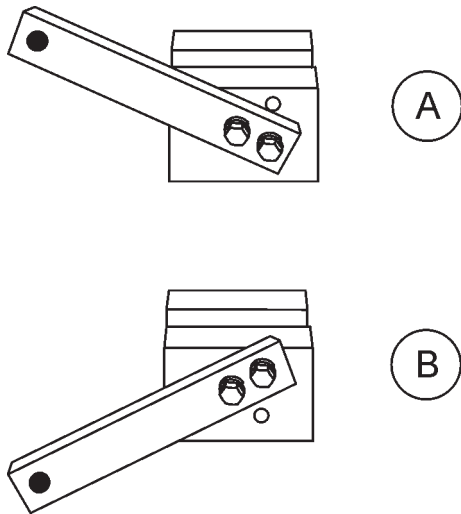

**Figure 30. Trowel Arm Adjustment Setup**

3. Unscrew the locking bolts on the adjustment tool and place the trowel arm into the fixture channel as shown in Figure 31. A **thin shim** may be required to cover the blade holes on the trowel arm. Make sure to align the **trowel** adjustment bolt with the **fixture** adjustment bolt.

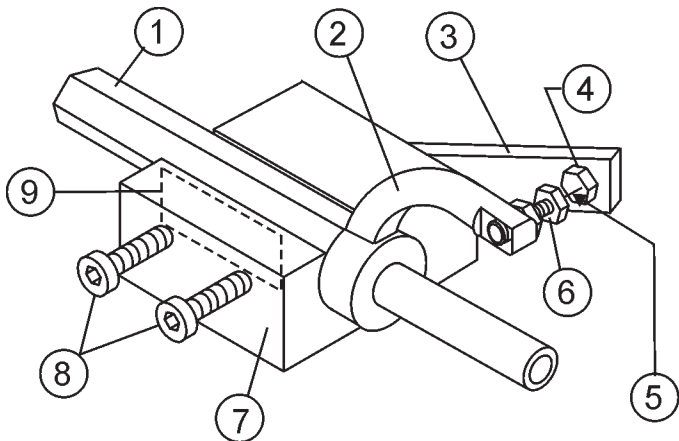

- |   |                               |
|---|-------------------------------|
| 1 | Arm                           |
| 2 | Trowel Arm Lever              |
| 3 | Fixture Arm                   |
| 4 | Adjustment Bolt               |
| 5 | Distance = .010 Inch          |
| 6 | Adjustment Bolt               |
| 7 | Trowel Arm Adjustment Fixture |
| 8 | Locking Bolts                 |
| 9 | Shim                          |

**Figure 31. Trowel Arm Adjustment Fixture Components**

4. Use an allen wrench to tighten the locking bolts securing the trowel arm in place.
5. Adjust the bolt "distance" shown in Figure 29 to match one of the arms. The other arms will be adjusted to match this distance.
6. Loosen the locking nut on the trowel arm lever, then turn the trowel arm adjusting bolt until it barely touches (.010") the fixture adjusting bolt.
7. Once the correct adjustment is made, tighten the lock nut on the trowel arm to lock in place.
8. Loosen locking nuts on the adjustment fixture, and remove trowel arm.
9. Repeat steps for the remaining trowel arms.

## Re-Assembly

1. Clean and examine the upper/lower wear plates and thrust collar. Examine the entire spider assembly. Wire brush any concrete or rust build-up. If any of the spider components are found to be damaged or out of round, replace them.
2. Make sure that the bronze trowel arm bushing is not damage or out of round. Clean the bushing if necessary. If the bronze bushing is damaged or worn, replace it.
3. Reinstall bronze bushing onto trowel arm.
4. Repeat steps 2 -3 for each trowel arm.
5. Make sure that the spring tensioner is in the correct position to exert tension on the trowel arm.
6. Insert all trowel arms with levers into spider plate (with bronze bushing already installed) using care to align grease hole on bronze bushing with grease hole fitting on spider plate.
7. Lock trowel arms in place by tightening the hex head bolt with zerk grease fitting and jam nut.
8. Re-install the blades onto the trowel arms.
9. Install stabilizer ring onto spider assembly.
10. Lubricate all grease points (zerk fittings) with premium "**Lithum 12**" based grease, conforming to NLG1 Grade #2 consistency.

## Changing a Blade

We recommend that **all the blades be changed at the same time**. The machine may wobble or bounce if only some of the blades are changed at one time.

1. Place the machine on a flat, level surface. Adjust the blade pitch control to make the blades as flat as possible. Note the blade orientation on the trowel arm.

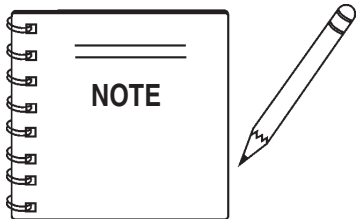

Before removing the blades, please note the orientation of the blade on the trowel arm.

1. Remove the two bolts and lock washers that secure the blade to the trowel arm. Remove the blade.
2. Using a wire brush, scrape all concrete particles and foreign debris from the trowel arm.
3. Install the new trowel blade onto the trowel arm. Make sure blade is installed correctly, maintaining the proper orientation for direction of rotation.
4. Reinstall the two bolts and lock washers that secure the blade to the trowel arm. Tighten both bolts securely.
5. Repeat steps 1 - 4 for all remaining blades.

## Hand Clutch Adjustment

This trowel is equipped with a hand-operated clutch that is a belt-tightener type clutch. It operates by removing **slack** in the V-belt which then transmits power from the engine to the gearbox.

There are two reasons to adjust the hand clutch: 1) operator comfort; 2) initial belt stretch and break-in.

The easiest and most simple adjustment is to adjust the clutch cable housing using the adjustment nut (Figure 32) located on the clutch lever. Rotating the nut provides either more or less (depending upon the direction of rotation) clutch engagement.

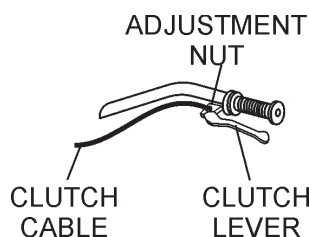
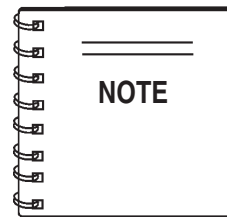

Figure 32. Trowel Arm Adjustment Tool



Check the manual clutch occasionally for proper operation. Checking operation of the manual clutch at the beginning of operation and periodically serves as a safety check verification.

## Hand Clutch Disengagement

1. Start the trowel as outlined in the "**Initial Start-up**" section in this manual. Move the throttle lever so that the engine is running about 1/4 to 1/3 of full speed.
2. Grip the trowel handle firmly and carefully engage the clutch by squeezing the clutch lever toward the handle with your left hand. After the trowel is stabilized and you feel comfortable with its operation, use your right hand to adjust the housing adjustment nut.
3. Rotating the nut so that it backs out of the lever housing increases the engagement and also the squeezing force required to keep it engaged.

Too much squeezing force may cause premature hand fatigue. Too little squeezing force may cause belt slippage and premature belt wear. Each operator should experiment with the adjustment to get the optimum combination of squeeze force and belt grip.

4. After initial break-in (approximately 8 hours) the above procedure should be repeated to attain optimum operator comfort and belt wear.
5. After considerable belt wear, the adjustments mentioned above may have a little or no effect on clutch engagement. If this is the case, the belt should be replaced.

## WARNING

**NEVER** attempt to override the manual clutch by using tape or other means to hold down the clutch lever. Doing so may cause **SEVERE INJURY**.

## Installing Pans Onto Finisher Blades



1. Lift trowel just enough to slide pan under blades. Lower finisher onto pan with blades (item #1) adjacent to Z-Clips (item #4).
2. Rotate blades into position under Z-Clips. Ensure that the blades are rotated in the direction of travel when the machine is in operation or use the engine to rotate the blades into position.
3. Attach the blade tie-downs (item #3) to the far side of the Z-Clip brackets (item #4) with tie-down knobs (item #2) as shown in figure 33.
4. Check to make certain that the blade edges are secured under the Z-Clips and the tie-downs are secured completely over the edges of the blade bar before the machine is put back into operation.

Refer to Figure 33 when installing pans onto finisher blades.

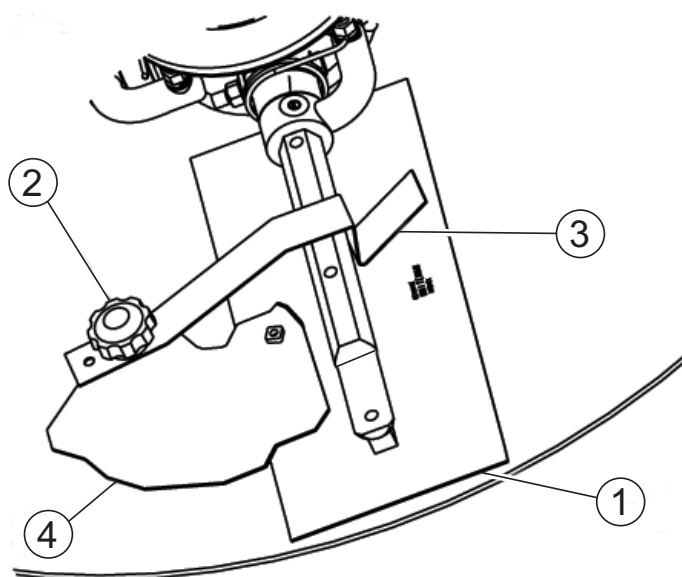

- |   |                            |
|---|----------------------------|
| 1 | BLADE ASSEMBLY             |
| 2 | KNOB, TIE DOWN Z-CLIP PANS |
| 3 | TIED OWN, BLADE            |
| 4 | Z-CLIP, PAN                |

Figure 33. Pan Installation

## Decommissioning Trowel/Components

Decommissioning is a controlled process used to safely retire a piece of equipment that is no longer serviceable. If the equipment poses an unacceptable and unreparable safety risk due to wear or damage or is no longer cost effective to maintain, (beyond life-cycle reliability) and is to be decommissioned, (demolition and dismantlement), the following procedure must take place:

1. Drain all fluids completely. These may include oil, gasoline, hydraulic oil and antifreeze. Dispose of properly in accordance with local and governmental regulations. Never pour on ground or dump down drains or sewers.
2. The remainder can be brought to a salvage yard or metal reclamation facility for further dismantling.



# CA4-4HM TROWEL — TROUBLESHOOTING (TROWEL)

**TABLE 5. TROUBLESHOOTING**

SYMPTOM	POSSIBLE PROBLEM	SOLUTION
Engine running rough or not at all.	Engine ON/OFF Switch in "OFF" position or malfunctioning?	Make sure that the Engine ON/OFF Switch is ON or replace switch if necessary.
	Fuel?	Look at the fuel system. Make sure there is fuel being supplied to the engine. Check to ensure that the fuel filter is not clogged.
	Ignition?	Check to ensure that the ignition switch has power and is functioning correctly.
	Loose wire connections?	Check wiring. Replace or repair as necessary.
	Bad contacts in ON/OFF switch?	Replace ON/OFF switch.
If trowel "bounces, rolls concrete, or makes uneven swirls in concrete".	Blades?	Make certain blades are in good condition, not excessively worn. Finish blades should measure no less than 2" (50mm) from the blade bar to the trailing edge, combo blades should measure no less than 3.5" (89mm). Trailing edge of blade should be straight and parallel to the blade bar.
	Pitch adjustment?	Check that all blades are set at the same pitch angle as measured at the spider. A field adjustment tool is available for height adjustment of the trowel arms. (Contact Parts Dept.)
	Bent trowel arms?	Check the spider assembly for bent trowel arms. If one of the arms is even slightly bent, replace it immediately.
	Spider?	Check fit of arms in spider. This can be done by moving the trowel arms up and down. If there is more than 1/8" (3.2 mm) of travel at the tip of the arm, the spider and arms should be replaced.
	Thrust collar?	Check the flatness of the thrust collar by rotating it on the spider. If it varies by more than 0.02" (0.5 mm) replace the thrust collar.
	Thrust collar?	Check the thrust collar by rocking it on the spider. If it can tilt more than 3/32" (2.4 mm) [as measured at the thrust collar O.D.], replace the thrust collar.
	Thrust bearing worn?	Check the thrust bearing to see that it is spinning free. Replace if necessary.
Machine has a perceptible rolling motion while running.	Main shaft?	The main output shaft of the gearbox assembly should be checked for straightness. The main shaft must run straight and cannot be more than 0.003" (0.08 mm) out of round at the spider attachment point.
	Yoke?	Check to make sure that both fingers of the yoke press evenly on the wear cap. Replace yoke as necessary.
	Blade Pitch?	Check to ensure that each blade is adjusted to have the same pitch as all other blades. Adjust per maintenance section in manual.

# CA4-4HM TROWEL — TROUBLESHOOTING (TROWEL)

TABLE 5. TROUBLESHOOTING (CONTINUED)

SYMPTOM	POSSIBLE PROBLEM	SOLUTION
Clutch slipping or sluggish response to engine speed change.	Worn V-belts?	Replace V-belt.
	Hand clutch out of adjustment?	Adjust per instructions in maintenance section of this manual.
	Worn or defective hand clutch parts?	Replace parts as necessary.
	Worn bearings in gearbox?	Rotate input shaft by hand. If shaft rotates with difficulty, check the input and output shaft bearings. Replace as necessary.
	Worn or broken gears in gearbox?	Verify that the gearbox shaft rotates when the input shaft is rotated. Replace both the worm and worm gear as a set.

# CA4-4HMTROWEL — TROUBLESHOOTING (ENGINE)

**TABLE 6. TROUBLESHOOTING (ENGINE)**

SYMPTOM	POSSIBLE CAUSE	SOLUTION
Difficult to start, "fuel is available, but no SPARK at spark plug".	Spark plug bridging?	Check gap, insulation or replace spark plug.
	Carbon deposit on spark plug?	Clean or replace spark plug.
	Short circuit due to deficient spark plug insulation?	Check spark plug insulation, replace if worn.
	Improper spark plug gap?	Set to proper gap.
Difficult to start, "fuel is available, and SPARK is present at the spark plug".	ON/OFF switch is shorted?	Check switch wiring, replace switch.
	Ignition coil defective?	Replace ignition coil.
	Improper spark gap, points dirty?	Set correct spark gap and clean points.
	Condenser insulation worn or short circuiting?	Replace condenser.
	Spark plug wire broken or short circuiting?	Replace defective spark plug wiring.
Difficult to start, "fuel is available, spark is present and compression is normal".	Wrong fuel type?	Flush fuel system, and replace with correct type of fuel.
	Water or dust in fuel system?	Flush fuel system.
	Air cleaner dirty?	Clean or replace air cleaner.
	Choke Open? (Engine cold)	Close Choke.
	Choke Closed? (Engine warm)	Open Choke.
Difficult to start, "fuel is available, spark is present and compression is low".	Suction/exhaust valve stuck or protruded?	Re-seat valves.
	Piston ring and/or cylinder worn?	Replace piston rings and or piston.
	Cylinder head and/or spark plug not tightened properly?	Torque cylinder head bolts and spark plug.
	Head gasket and/or spark plug gasket damaged?	Replace head and spark plug gaskets.
No fuel present inside priming bulb.	Fuel not available in fuel tank?	Fill with correct type of fuel.
	Fuel filter clogged?	Replace fuel filter.
	Fuel tank cap breather hole clogged?	Clean or replace fuel tank cap.
	Air in fuel line?	Bleed fuel line.



**PAYMENT TERMS**

Terms of payment for parts are net 10 days.

**FREIGHT POLICY**

All parts orders will be shipped collect or prepaid with the charges added to the invoice. All shipments are F.O.B. point of origin. Multiquip's responsibility ceases when a signed manifest has been obtained from the carrier, and any claim for shortage or damage must be settled between the consignee and the carrier.

**MINIMUM ORDER**

The minimum charge for orders from Multiquip is \$15.00 net. Customers will be asked for instructions regarding handling of orders not meeting this requirement.

**RETURNED GOODS POLICY**

Return shipments will be accepted and credit will be allowed, subject to the following provisions:

1. A Returned Material Authorization (RMA) must be approved by Multiquip prior to shipment.
2. To obtain a Return Material Authorization, a list must be provided to Multiquip Parts Sales that defines item numbers, quantities, and descriptions of the items to be returned.
  - a. The parts numbers and descriptions must match the current parts price list.
  - b. The list must be typed or computer generated.
  - c. The list must state the reason(s) for the return.
  - d. The list must reference the sales order(s) or invoice(s) under which the items were originally purchased.
  - e. The list must include the name and phone number of the person requesting the RMA.
3. A copy of the Return Material Authorization must accompany the return shipment.
4. Freight is at the sender's expense. All parts must be returned freight prepaid to Multiquip's designated receiving point.

5. Parts must be in new and resalable condition, in the original Multiquip package (if any), and with Multiquip part numbers clearly marked.
6. The following items are not returnable:
  - a. Obsolete parts. (If an item is in the price book and shows as being replaced by another item, it is obsolete.)
  - b. Any parts with a limited shelf life (such as gaskets, seals, "O" rings, and other rubber parts) that were purchased more than six months prior to the return date.
  - c. Any line item with an extended dealer net price of less than \$5.00.
  - d. Special order items.
  - e. Electrical components.
  - f. Paint, chemicals, and lubricants.
  - g. Decals and paper products.
  - h. Items purchased in kits.
7. The sender will be notified of any material received that is not acceptable.
8. Such material will be held for five working days from notification, pending instructions. If a reply is not received within five days, the material will be returned to the sender at his expense.
9. Credit on returned parts will be issued at dealer net price at time of the original purchase, less a 15% restocking charge.
10. In cases where an item is accepted for which the original purchase document can not be determined, the price will be based on the list price that was effective twelve months prior to the RMA date.
11. Credit issued will be applied to future purchases only.

**PRICING AND REBATES**

Prices are subject to change without prior notice. Price changes are effective on a specific date and all orders received on or after that date will be billed at the revised price. Rebates for price declines and added charges for price increases will not be made for stock on hand at the time of any price change.

**PRICING AND REBATES**

Prices are subject to change without prior notice. Price changes are effective on a specific date and all orders received on or after that date will be billed at the revised price. Rebates for price declines and added charges for price increases will not be made for stock on hand at the time of any price change.

Multiquip reserves the right to quote and sell direct to Government agencies, and to Original Equipment Manufacturer (OEM) accounts who use our products as integral parts of their own products.

**SPECIAL EXPEDITING SERVICE**

A \$35.00 surcharge will be added to the invoice for special handling including bus shipments, insured parcel post or in cases where Multiquip must personally deliver the parts to the carrier.

**LIMITATIONS OF SELLER'S LIABILITY**

Multiquip shall not be liable hereunder for damages in excess of the purchase price of the item with respect to which damages are claimed, and in no event shall Multiquip be liable for loss of profit or good will or for any other special, consequential or incidental damages.

**LIMITATION OF WARRANTIES**

No warranties, expressed or implied, are made in connection with the sale of parts or trade accessories nor as to any engine not manufactured by Multiquip. Such warranties made in connection with the sale of new, complete units are made exclusively by a statement of warranty packaged with such units, and Multiquip neither assumes nor authorizes any person to assume for it any other obligation or liability whatever in connection with the sale of its products. Apart from such written statement of warranty, there are no warranties, expressed, implied or statutory, which extend beyond the description of the products on the face hereof.

# OPERATION MANUAL

## **HERE'S HOW TO GET HELP**

PLEASE HAVE THE MODEL AND SERIAL  
NUMBER *ON-HAND* WHEN CALLING

### **MULTIQUIP'S MAIN PHONE NUMBERS**

800-421-1244      FAX: 310-537-3927  
310-537-3700

### **PARTS DEPARTMENT**

800-427-1244      FAX: 800-672-7877  
310-537-3700      FAX: 310-637-3284

### **MAYCO PARTS**

800-306-2926      FAX: 800-672-7877  
310-537-3700      FAX: 310-637-3284

### **SERVICE DEPARTMENT**

800-478-1244      FAX: 310-537-4259  
310-537-3700

### **MQ POWER SERVICE DEPARTMENT**

800-835-2551      FAX: 310-638-8046  
310-537-3700

### **TECHNICAL ASSISTANCE**

800-478-1244      FAX: 310-631-5032

### **WARRANTY DEPARTMENT**

Your Local Dealer is:



**MULTIQUIP INC.**  
POST OFFICE BOX 6254  
CARSON, CA 90749  
310-537-3700 • 800-421-1244  
FAX: 310-537-3927  
E-MAIL: [mq@multiquip.com](mailto:mq@multiquip.com)  
WWW: [multiquip.com](http://multiquip.com)

Atlanta • Boise • Newark  
Montreal, Canada • Manchester, UK • Rio De Janeiro, BR • Guadalajara, MX