

# OPERATION AND PARTS MANUAL



## **CV-SERIES VIBRATOR MOTOR**

**MODEL CV-1  
MODEL CV-2  
MODEL CV-2E  
MODEL CV-3  
MODEL CV-3E**

Revision #1 (06/13/07)

To find the latest revision of this  
publication, visit our website at:  
[www.multiquip.com](http://www.multiquip.com)



**THIS MANUAL MUST ACCOMPANY THE EQUIPMENT AT ALL TIMES.**

**P/N 36686**



## WARNING



### **CALIFORNIA — Proposition 65 Warning**

Engine exhaust and some of its constituents, and some dust created by power sanding, sawing, grinding, drilling and other construction activities contains chemicals known to the State of California to cause cancer, birth defects and other reproductive harm. Some examples of these chemicals are:

- Lead from lead-based paints.
- Crystalline silica from bricks.
- Cement and other masonry products.
- Arsenic and chromium from chemically treated lumber.

Your risk from these exposures varies, depending on how often you do this type of work. To reduce your exposure to these chemicals: **ALWAYS** work in a well ventilated area, and work with approved safety equipment, such as dust masks that are specially designed to filter out microscopic particles.

## **WARNING**



### **SILICOSIS WARNING**

Grinding/cutting/drilling of masonry, concrete, metal and other materials with silica in their composition may give off dust or mists containing crystalline silica. Silica is a basic component of sand, quartz, brick clay, granite and numerous other minerals and rocks. Repeated and/or substantial inhalation of airborne crystalline silica can cause serious or fatal respiratory diseases, including silicosis. In addition, California and some other authorities have listed respirable crystalline silica as a substance known to cause cancer. When cutting such materials, always follow the respiratory precautions mentioned above.

## **WARNING**

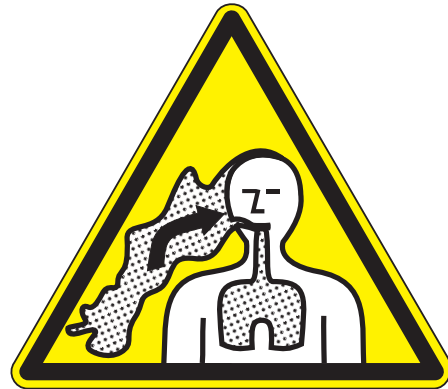

### **RESPIRATORY HAZARDS**

Grinding/cutting/drilling of masonry, concrete, metal and other materials can generate dust, mists and fumes containing chemicals known to cause serious or fatal injury or illness, such as respiratory disease, cancer, birth defects or other reproductive harm. If you are unfamiliar with the risks associated with the particular process and/or material being cut or the composition of the tool being used, review the material safety data sheet and/or consult your employer, the material manufacturer/supplier, governmental agencies such as OSHA and NIOSH and other sources on hazardous materials. California and some other authorities, for instance, have published lists of substances known to cause cancer, reproductive toxicity, or other harmful effects.

Control dust, mist and fumes at the source where possible. In this regard use good work practices and follow the recommendations of the manufacturers or suppliers, OSHA/NIOSH, and occupational and trade associations. Water should be used for dust suppression when wet cutting is feasible. When the hazards from inhalation of dust, mists and fumes cannot be eliminated, the operator and any bystanders should always wear a respirator approved by NIOSH/MSHA for the materials being used.

## MQ MULTIQUIP — CV-SERIES VIBRATOR MOTOR

Proposition 65 Warning .....	2
Silicosis/Respiratory Warnings .....	3
Table Of Contents .....	4
Parts Ordering Procedures .....	5
Safety Message Alert Symbols .....	6
Rules For Safe Operation .....	7-9
Specifications .....	10
Decals .....	11
Preparation .....	12
Operation .....	13
Maintenance .....	14-16
Troubleshooting .....	17
Vibrator Motor Housing .....	18-19
Vibrator Motor Assembly .....	20-21
Terms and Conditions of Sale .....	22

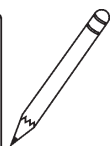
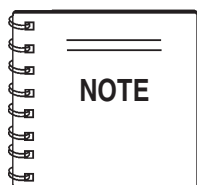

Specifications and part numbers are subject to change without notice.

www.multiquip.com

**Ordering parts has never been easier!  
Choose from three easy options:**



**Order via Internet (Dealers Only):**

Order parts on-line using Multiquip's SmartEquip website!

- View Parts Diagrams
- Order Parts
- Print Specification Information



If you have an MQ Account, to obtain a Username and Password, E-mail us at: [parts@multiquip.com](mailto:parts@multiquip.com).

To obtain an MQ Account, contact your District Sales Manager for more information.

Goto [www.multiquip.com](http://www.multiquip.com) and click on

**Order Parts** to log in and save!

Use the **internet** and qualify for a **5% Discount** on *Standard orders* for all orders which include complete part numbers.\*

Note: Discounts Are Subject To Change



**Order via Fax (Dealers Only):**

All customers are welcome to order parts via Fax.

**Domestic (US) Customers dial:**  
1-800-6-PARTS-7 (800-672-7877)

**Fax** your order in and qualify for a **2% Discount** on *Standard orders* for all orders which include complete part numbers.\*

Note: Discounts Are Subject To Change



**Order via Phone: Domestic (US) Dealers Call:**  
1-800-427-1244

**Non-Dealer Customers:**

Contact your local Multiquip Dealer for parts or call 800-427-1244 for help in locating a dealer near you.



**International Customers** should contact their local Multiquip Representatives for Parts Ordering information.

**When ordering parts, please supply:**

- |   |  |
|---|--|
| <input type="checkbox"/> Dealer Account Number                                | <input type="checkbox"/> Specify Preferred Method of Shipment:                         |
| <input type="checkbox"/> Dealer Name and Address                              | <input checked="" type="checkbox"/> UPS/Fed Ex <input checked="" type="checkbox"/> DHL |
| <input type="checkbox"/> Shipping Address (if different than billing address) | <input type="checkbox"/> Priority One <input checked="" type="checkbox"/> Truck        |
| <input type="checkbox"/> Return Fax Number                                    | <input type="checkbox"/> Ground  |
| <input type="checkbox"/> Applicable Model Number                              | <input type="checkbox"/> Next Day  |
| <input type="checkbox"/> Quantity, Part Number and Description of Each Part   | <input type="checkbox"/> Second/Third Day  |

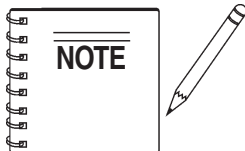

All orders are treated as *Standard Orders* and will ship the same day if received prior to 3PM PST.

**WE ACCEPT ALL MAJOR CREDIT CARDS!**



# CV-SERIES — SAFETY MESSAGE ALERT SYMBOLS

## FOR YOUR SAFETY AND THE SAFETY OF OTHERS!

Safety precautions should be followed at all times when operating this equipment. Failure to read, understand and comply with the Safety Messages and Operating Instructions could result in injury to yourself and others.

This Operation Manual has been developed to provide instructions for the safe and efficient operation of the CV - Series Vibrator Motor.



**Before using this Vibrator Motor, ensure that the operating individual has read, understands, and complies with all instructions in this manual.**

## SAFETY MESSAGE ALERT SYMBOLS

The three (3) Safety Messages shown below will inform you about potential hazards that could injure you or others. The Safety Messages specifically address the level of exposure to the operator, and are preceded by one of three words: **DANGER**, **WARNING**, or **CAUTION**.

### **DANGER**

You **WILL** be **KILLED** or **SERIOUSLY INJURED** if you **DO NOT** follow these directions.

### **WARNING**

You **CAN** be **KILLED** or **SERIOUSLY INJURED** if you **DO NOT** follow these directions.

### **CAUTION**

You **CAN** be **INJURED** if you **DO NOT** follow these directions.

Potential hazards associated with vibrator motor operation will be referenced with Hazard Symbols which appear throughout this manual, and will be referenced in conjunction with Safety Message Alert Symbols.

## HAZARD SYMBOLS

### **Accidental Starting**

Accidental starts can cause severe injury or death. **ALWAYS** place the ON/OFF switch in the OFF position when the Vibrator Motor is not in use.

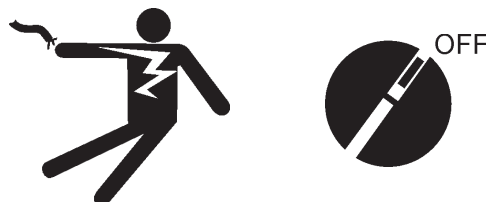

### **Explosive Fuel**



Gasoline is extremely flammable, and its vapors can cause an explosion if ignited. **DO NOT** start the Vibrator Motor near spilled fuel or combustible fluids. **NEVER** operate the Vibrator Motor in an explosive atmosphere or near combustible materials. An explosion or fire could result causing severe **bodily harm or even death**.

### **Burn Hazards**



Engine components can generate extreme heat. To prevent burns, **DO NOT** touch these areas while the engine is running or immediately after operations. **NEVER** operate the engine with heat shields or heat guards removed.

### **Rotating Parts**



**NEVER** operate equipment with covers, or guards removed. Keep **fingers, hands, hair** and **clothing** away from all moving parts to prevent injury.

### **Sight and Hearing hazard**

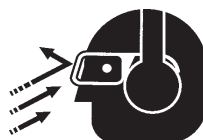

**ALWAYS** wear approved eye and hearing protection.

# CV-SERIES — RULES FOR SAFE OPERATION

## RULES FOR SAFE OPERATION

### **WARNING**

Failure to follow instructions in this manual may lead to serious injury or even death! This equipment is to be operated by trained and qualified personnel only! This equipment is for industrial use only.

The following safety guidelines should always be used when operating the CV-SERIES Vibrator Motor.

### GENERAL SAFETY RULES

- **DO NOT** operate or service this equipment before you read, understand, and comply with all safety messages in this manual. The manual must be kept available and accessible to the operator. 
- This equipment should not be operated by persons under the minimum statutory age limit.
- Keep untrained personnel away. **DO NOT** let visitors contact the vibrator unit. All visitors should be kept away from the work area.
- **NEVER** operate a vibrator motor while under the influence of drugs, alcohol, or medications that may impair the senses or reactions.
- **NEVER** use this machine for any purpose other than those described in this manual.
- Dress properly. Wear appropriate clothing and protective safety equipment. Wear clothing that will not likely become caught in the equipment or snag on the forms. Eye, hand, hearing, and foot safety equipment is required.



- **NEVER** use accessories or attachments which are not recommended by the manufacturer for this equipment. Damage to the equipment and/or injury to user may result.

- Manufacturer does not assume responsibility for any accident due to equipment modifications. Unauthorized equipment modification will void all warranties. Any modification which could lead to a change in the original characteristics of the machine should be made only by the manufacturer who shall confirm that the machine is in conformity with appropriate safety regulations.
- Replace nameplate, operation and safety decals when they become difficult to read.
- Always observe all applicable compulsory regulations relevant to environmental protection, especially, fuel storage, the handling of hazardous substances, and the wearing of protective clothing and equipment. Instruct the user as necessary, or, as the user, request this information and training.

### VIBRATOR MOTOR OPERATION SAFETY RULES

- Keep work area well lit.
- Keep work area clean and well organized. A cluttered area invites injuries.
- **ALWAYS** clear the work area of any debris, tools, etc. that would constitute a hazard while the vibrator motor is in operation.
- **ALWAYS** be sure the operator is familiar with proper safety precautions and operations techniques before using vibrator motor.
- **DO NOT** overreach. Keep proper footing and balance at all times.
- Secure forms. Make sure the form work is well made and braced to withstand the stresses made by vibration.
- **ALWAYS** check the vibrator motor for loosened hardware such as nuts and bolts before starting.
- Keep vibrator motor clean for better and safer operation.
- Inspect motor cord periodically and if damaged, have it repaired by an authorized service facility.
- Before each use **ALWAYS** check the motor to make certain there are no damaged parts, and that all parts function properly, (examples: switch, cord housing). If any damage or malfunctioning parts are found, have them repaired or replaced by an authorized service facility.
- Use only factory authorized identical **replacement parts**.

# CV-SERIES — RULES FOR SAFE OPERATION

- Before plugging the motor into a power source, **ALWAYS** remove any wrenches or other tools from the motor, shaft, and head that were used for assembly.
- Be sure switch is in the "OFF" position before plugging the motor into a power source.
- **DO NOT** carry plugged-in motor with finger on the switch.
- **NEVER** use the motor with a defective switch. If the switch does not turn the motor "ON" or "OFF", have it replaced before using the motor.
- **NEVER** carry the motor by the cord. Use the carrying frame.
- Keep the cord from heat, oil, and sharp objects.
- **DO NOT** overload the motor. It will do a better and safer job at the rate for which it was designed.
- **DO NOT** force the motor and head to do the job of a larger motor and head.
- **DO NOT** expose vibrator motor to rain.
- **DO NOT** use vibrator motor in damp or wet locations without proper electrical circuits.

- **NEVER** operate the vibrator motor in an explosive atmosphere where fumes are present, or near combustible materials. An explosion or fire could result in severe **bodily harm or even death**.

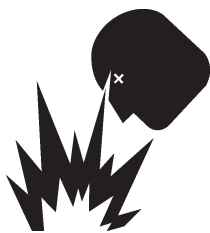

- **ALWAYS** keep clear of **rotating** or **moving parts** while operating the vibrator motor.
- **NEVER** leave the machine **unattended** while running.
- **ALWAYS** turn the motor off and unplug the power cord before performing service or maintenance functions.
- **DO NOT** yank the cord to disconnect it from the receptacle. Grasp the plug itself to disconnect it.
- **ALWAYS** disconnect the motor from the power source when not in use, before servicing, and when changing flexible shafting and vibrator heads.

- Allow the vibrator motor to cool before servicing. Contact with **hot!** components can cause serious burns.



- Store idle vibrator motor. When not in use, motor should be stored in a dry, safe storage area.

## VIBRATOR MOTOR ELECTRICAL SAFETY RULES

### **WARNING**

When using electric tools, basic safety precautions **MUST** be followed to reduce the risk of fire and electric shock.



1. Know your concrete vibrator. Read this instruction manual. Learn the vibrator's applications, limitations, and specific potential hazards peculiar to this tool.
  2. Guard against electrical shock.
  3. Prevent body contact with grounded surfaces. (For example: pipes, reinforcing bar, etc.)
- Use a protection wiring device, such as a Ground Fault Circuit Interrupter, for the protection of personnel.
  - This concrete vibrator motor is equipped with a 3-conductor cord, and a 3-prong grounding type plug to fit the proper grounding type receptacle. The green conductor in the cord is the ground wire. **NEVER** connect the green wire to a live terminal. See (Figure 1) for proper grounding methods.

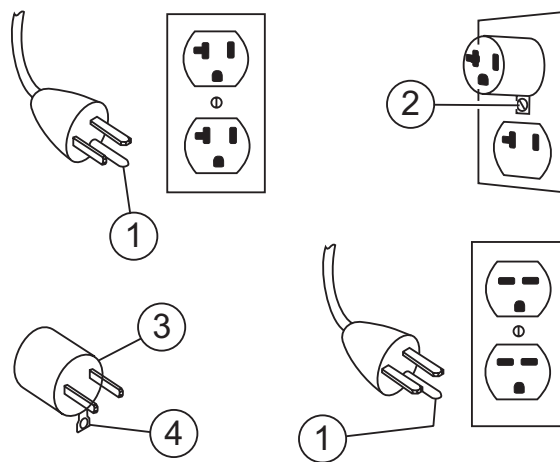

1. Grounding Pin
2. Metal Screw
3. Adapter
4. Grounding Means

Figure 1. Grounding Methods (Typical)

# CV-SERIES — RULES FOR SAFE OPERATION

## WARNING

**ALWAYS** use a grounded 3-wire extension cord that has a 3-prong grounding plug, and a 3-pole receptacle that accepts the plug on the concrete vibrator motor. **DO NOT REMOVE THE GROUNDING PIN FROM THE PLUG!**

## WARNING

**MAKE CERTAIN** the motor is connected to a **GROUND FAULT CIRCUIT INTERRUPTER** to protect the operator from possible electric shock.

### 4. Use of extension cords.

- **MAKE CERTAIN** the power cord/extension cord is free from damage, and that the grounding circuit is operational. Repair or replace all damaged cords and grounding units.
- When extending the cord, **DO NOT** submerge the connection in water. Avoid the possibility of electric shock by **ALWAYS** making water-tight connections.

TABLE 1. Extension Cord Sizes

Ampere Rating Range	Volts	Length of Cord in Feet					
	115V	25 Ft.	50 Ft.	100 Ft.	150 Ft.	200 Ft.	250 Ft.
		230V	50 Ft.	100 Ft.	200 Ft.	300 Ft.	400 Ft.
0 - 2	18	18	18	16	16	14	
2 - 3	18	18	16	14	14	12	
3 - 4	18	18	16	14	12	12	
4 - 5	18	18	14	12	12	10	
5 - 6	18	16	14	12	10	10	
6 - 8	18	16	12	10	10	8	
8 - 10	18	14	12	10	8	8	
10 - 12	16	14	10	8	8	6	
12 - 14	16	12	10	8	6	6	
14 - 16	16	12	10	8	6	6	
16 - 18	14	12	8	8	6	4	
18 - 20	14	12	8	6	6	4	

- Use only extension cords that are intended for outdoor use and so marked.
- Use only the gauge wire and length of cord recommended for the motor size. If in doubt, go to the next heavier gauge. (The smaller the gauge number, the heavier the cord.)
- See (Table 1) for recommended extension cord sizes.

## CAUTION

Use of an extension cord with a wire gauge smaller than, or length longer than that stated previously could result in reduced motor performance and/or damage to the motor or extension cord due to overheating.

### Emergencies

- **ALWAYS** know the location of the nearest **fire extinguisher**.



- **ALWAYS** know the location of the nearest **first aid kit**.



- Know the phone numbers of the nearest **ambulance, doctor** and **fire department**. Ensure that a phone or radio is readily available at the jobsite. If this is not possible, know the location of the nearest phone. This information will be invaluable in the event of an emergency.



# CV-SERIES— SPECIFICATIONS (VIBRATOR MOTOR)

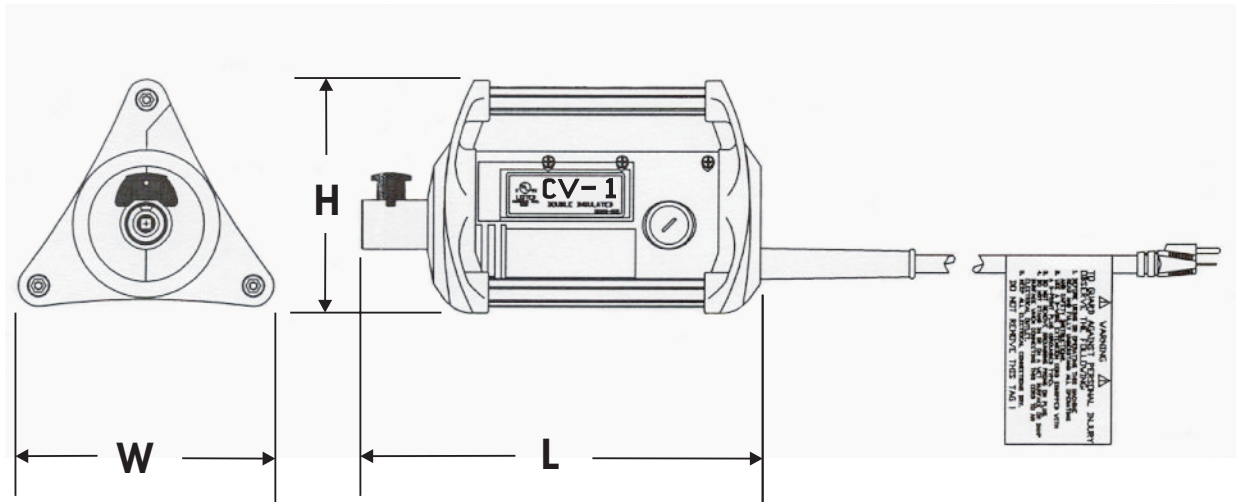

Figure 2. Dimensions

TABLE 2. SPECIFICATIONS

Model	CV-1	CV-2/CV-2E		CV-3/CV-3E	
Horsepower	1HP (0.746 kW)	2HP (1.492 kW)		3HP (2.238 kW)	
Length	13.5" (343mm)	13.5" (343mm)		13.5" (343mm)	
Width	8.75" (222.25mm)	8.75" (222.25mm)		8.75" (222.25mm)	
Height	7.75" (196.85mm)	7.75" (196.85mm)		7.75" (196.85mm)	
Weight	11 LBS. (4989.5g)	12.5 LBS. (5669.9g)		13.5 LBS. (6123.5g)	
RPM (No Load)	22,000 RPM	22,000 RPM		22,000 RPM	
Volts	115VAC	115VAC	230VAC	115VAC	230VAC
Amps	10A	15A	7.5A	20A	10A
Hertz	50/60Hz	50/60Hz		50/60Hz	

# CV-SERIES — OPERATION AND SAFETY DECALS

## Machine Safety Decals

The CV-SERIES VIBRATOR MOTOR is equipped with a number of operation and safety decals. These decals are provided for operator safety and maintenance information. Should any of these decals become unreadable, replacements can be obtained from your dealer.



P/N 00100-57



P/N 00100-59



P/N 00100-62



P/N 00100-61



P/N 00100-63



P/N 00100-46

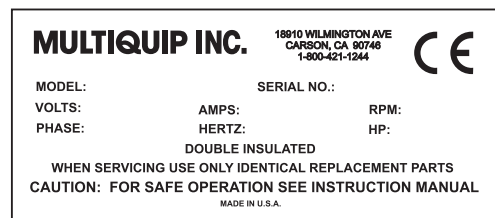

CONTACT SERVICE DEPARTMENT



P/N 00100-44

Figure 3. Decals

# CV-SERIES — PREPARATION AND OPERATION

Before using your Vibrator Motor, read and fully understand all of the safety and operating instructions not only for the motor, but also for the flexible shafting and the head that will be used with the motor.



1. The vibrator motor, flexible shafting, and heads are shipped from the factory ready to use. Connect per instruction bulletins.
2. Use only the combination of flexible shafting and heads shown below in Table 3.

MODEL	SHAFT	HEAD SIZE	MAX. SHAFT LENGTH
SVA-1	314V	900 1000 1300	21 FT.
SVA-2	382V	1400 1700	28 FT.
		2100	21 FT.
SVA-3	382V	1400 1700 2100 2600	35 FT.

3. To connect the 314V or 382V flexible shafting to the vibrator motor see illustration (Figure 4).

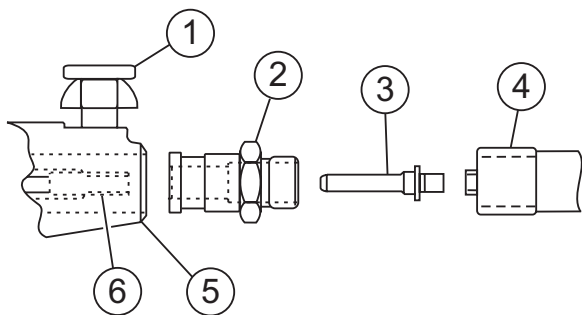

1. Lock Assembly
2. Shaft Coupling Quick Disconnect
3. Spindle Shaft
4. Core Fitting
5. Motor
6. Drive Coupler Quick Disconnect

Figure 4. Motor-to-Shaft Connection

## ! WARNING

**MAKE CERTAIN** the motor is disconnected from the power source and the switch is in the "OFF" position.

4. Slide the core out of the casing far enough to thread the spindle (Item 3 Fig. 4) into the core fitting and tighten. A pair of pliers and a wrench can be used to tighten the connection. It is important that this connection is tight. If it is not, the torque of the motor plus the load of the head will jam the two fittings together making it extremely hard to loosen them for disassembly.
5. Thread the shaft coupling (Item 2 Fig. 4) into the casing ferrule and tighten.
6. Pull up on the lock pin and slide the shaft assembly into the front motor bearing housing and release the lock pin. Give the shaft assembly a twist to make sure that the lock pin is seated in the lock groove of the shaft coupling.
7. Clean the mating parts threads with Locquic Primer "T". Allow to dry several minutes before applying a ring of Loctite No. 271 or equivalent to the middle of the casing threads. Screw the head tightly to the casing and wait 1 hour before using. Threads are **left-hand**; turn **counter-clockwise** to tighten.

## ! CAUTION

If the shaft begins to helix (buckle) excessively during operation, stop and investigate. This is an indication of an overload condition.

## ! CAUTION

The vibrator head is cooled by the concrete. Operation of the vibrator head in air longer than 2 minutes at a time will cause overheating of the bearings which will result in premature head failure.

## ! CAUTION

Visually inspect the air intake and exhaust frequently to make sure the motor has sufficient air for cooling.

**CV-Series Vibrator Motor Familiarization**

This **VIBRATOR MOTOR** is designed for the **compaction** of concrete by removal of air pockets and voids.

The action of vibration is to set the particles in the fresh concrete in motion, thereby reducing the friction between the particles and giving the mixture the mobile quality of a thick fluid so gravity and the displacement of entrapped air will cause it to settle easily into place.

By consolidating the concrete quickly, "stiffer" or "drier" mixes can be poured than would otherwise be possible. It has been proven that (up to a point) the drier the concrete, (that is, the less water in it), the better the quality throughout and the greater the strength.

Drier mixes also make the concrete more water tight, increase resistance to weathering, and create a better bond between concrete and reinforcement. Because vibration causes much of the entrapped air in the concrete to rise to the surface, honeycombing is prevented. Vibration also eliminates most of the air pockets between the concrete and the vertical forms.

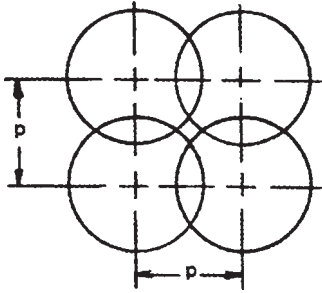

**Figure 5. Compaction Coverage with 50% Radial Overlap**

**CV-SERIES VIBRATOR MOTOR OPERATION**

**Read** all the safety instructions carefully. Safety instructions will be found throughout this manual and on the Vibrator Motor. Keep all safety information in good, readable condition.

1. Make certain that the flexible shaft is properly attached to the motor and the head to the flexible shaft.
2. Use the flexible shaft in as straight a position as possible.
3. **DO NOT** bend the flexible shaft sharply at any point. Sharp bends may cause a permanent kink, requiring early replacement of the flexible shaft.
4. With the vibrator motor properly plugged into the correct power source, turn the **ON/OFF** switch to the "ON" position and proceed to insert the vibrator into the concrete. 
5. The concrete is normally placed in the forms in layers about 12 to 18 inches thick in a manner which forms a fairly level surface. The vibrator head is inserted vertically into the top of the pile.
6. **DO NOT** insert the head into the side of the pile to make the concrete flow as this practice can cause segregation of the aggregate from the mortar. When the surface has become fairly level, the head should be immersed and generally moved in the pattern shown in Figure 5.

Table 4. Compaction Coverage							
Head	900	1000	1300	1400	1700	2100	2600
P-Dimension	4"	5-1/2"	8"	8"	12"	14"	18"

7. Immerse the head for 5 to 10 seconds, (until air stops rising), and then withdraw it slowly to let the concrete fill the void left by the head.
8. The head should be completely below the surface when vibrating to keep the head cool.
9. When vibrating a thin horizontal slab, the head can be used in a horizontal position.

## MAINTENANCE

### CAUTION

Before performing any maintenance on this unit, **ALWAYS MAKE CERTAIN** that the switch is in the "OFF" position and the power cord is disconnected from the power source.

This is a universal motor and it will run at approximately its rated speed if the motor and its attached equipment are properly operated and maintained.

1. Have repair work performed by an authorized service facility, using identical or manufacturer approved replacement parts.
2. This motor uses sealed bearings and does not require lubrication.
3. Visually inspect the motor daily before use for defective or missing parts, and have repairs made before use.
4. Inspect brushes frequently and replace when they become worn to a length of 3/8". (See Length A in Figure 6).

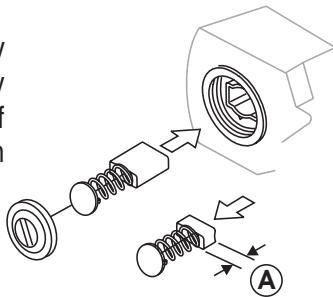

**Figure 6. Brush Length**

5. Keep air inlet and air exit louvers clean and free of concrete and debris. Failure to do so will result in rapid motor overheating and parts failure.
6. Clean air filter as needed. If unit is used in high dust areas, filter will have to be cleaned more often.
7. Use a screw driver to tighten brush caps. **DO NOT OVERTIGHTEN**. The brush cap must be tight enough that the brush holder does not move.
8. The 314V and 382V flexible shafts require cleaning and relubrication every 100 hours of operation. Refer to flexible shafting operating instructions for maintenance instructions.
9. Vibrator heads should be inspected and relubricated every 100 hours of operation. Follow the instructions for vibrator heads.

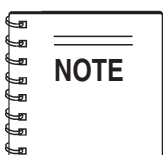

Heat should be used to break down the threadlock (loctite) while you unthread the head from the shaft. This will help prevent damage to the threads.

### Bronze Wear Bushing Replacement

Refer to Figure 7 and the following steps for removal and replacement of the bronze wear bushing.

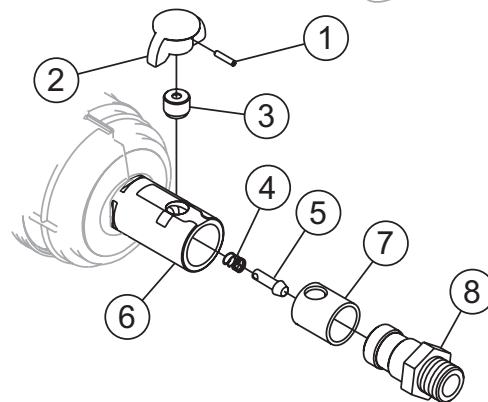
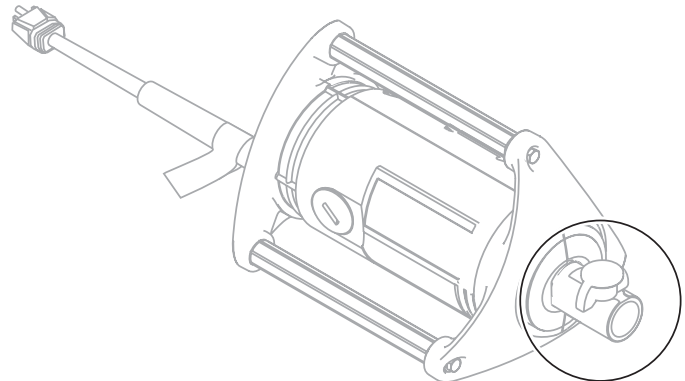

1. Slotted Spring Pin
2. Quick Disconnect Knob
3. Spring Housing
4. Compression Spring
5. Lock Pin
6. Output Endbell Shaft
7. Bronze Wear Bushing
8. Shaft Coupling

**Figure 7. Bronze Wear Bushing**

1. If installed, remove head assembly and shaft coupling (item 8, Figure 7).
2. Remove pin (item 1, Figure 7) using hammer and punch of appropriate size.
3. Once the pin is removed, the knob, spring and lock pin can easily be removed. (items 2, 4, and 5)

4. Using channel lock style pliers with soft jaws, unscrew the spring housing (item 3). Heat may need to be applied to break down the old threadlock to prevent damage to the threads on the spring housing.
5. After the spring housing is removed, use a 3-jaw bearing puller to remove the bronze wear bushing, (item 7).
6. To install a new bronze wear bushing, first align the hole in the new bushing with the spring housing hole. Press the bushing straight and evenly into place using a block of wood or soft aluminum and a mallet. Bushing should be flush with the end of the shaft when fully seated.
7. Clean all old threadlock from the spring housing and apply new threadlock (Loctite blue 242 or equivalent).
8. Screw the spring housing firmly into place using channel lock style pliers with soft jaws.
9. Reinstall the lock pin, spring and knob and secure with pin.
10. Verify the Quick Disconnect Knob operates freely and snaps back into position. If the knob stays in the up position there is binding occurring between the knob, spring, or lock pin.

## Motor Reassembly

If the motor required disassembly for servicing, reinstalling the assembly back into the case will be much easier if all internal components are reassembled as a unit first.

Refer to Figure 8 or the Vibrator Motor Assembly illustration on page 22 when performing the following steps.

1. Place the Brush Endbell (item 1, Figure 8) on work surface with bearing pocket up.
2. Place two plastic insulators (items 2) in the holes on the endbell.
3. Slide the Field Assembly (item 4), with the leads toward the endbell, into place ensuring the plastic insulators engage into the field holes.
4. Plug the brush flag leads (see Figure 9, Field Orientation) into the top of the brush holders toward the output shaft end. (See Figure 10).
5. Install the Armature/bearings Assembly (item 5) and Wave Spring (item 3) through the Field and into the endbell bearing pocket.
6. Place the remaining two plastic insulators (items 6) into the holes of the Output Endbell (item 7).

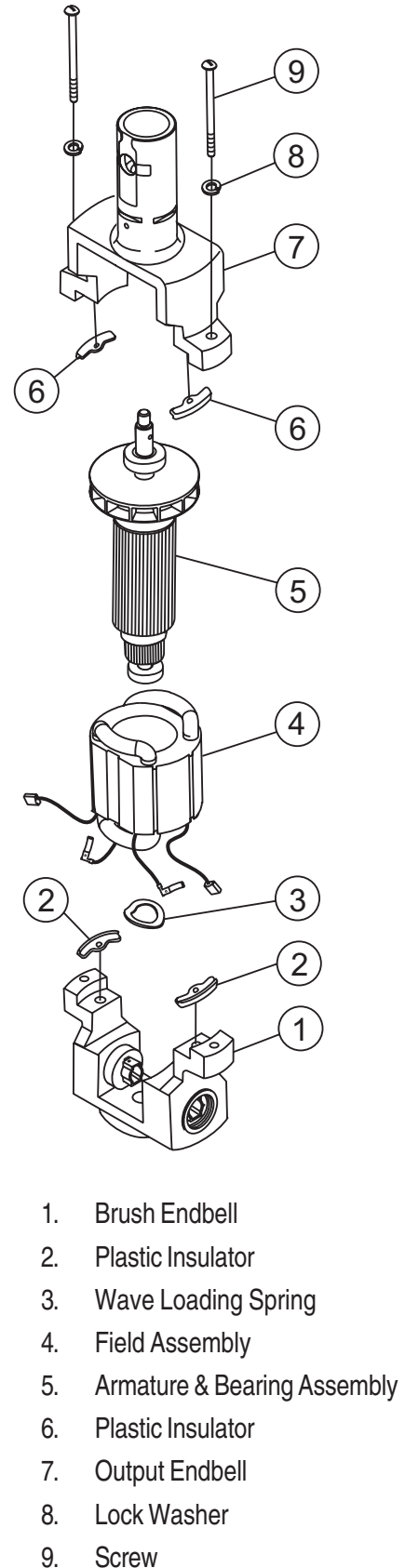

1. Brush Endbell
2. Plastic Insulator
3. Wave Loading Spring
4. Field Assembly
5. Armature & Bearing Assembly
6. Plastic Insulator
7. Output Endbell
8. Lock Washer
9. Screw

**Figure 8. Motor Assembly**

7. Slide the Output Endbell (item 7) down onto the Armature/Bearing Assembly (item 5) so the bearing engages the bearing pocket of the endbell and insulators seat properly on the Field.
8. Install the lockwashers and long screws through both endbells as shown and torque to 50-70 in. lbs. (5.65 N-m to 7.91 N-m).
9. Place the motor assembly into the plastic housing half that has the threaded inserts. (item 1 Figure 11)

**Field Orientation (Figure 9) (when viewed from the rear of the motor)**

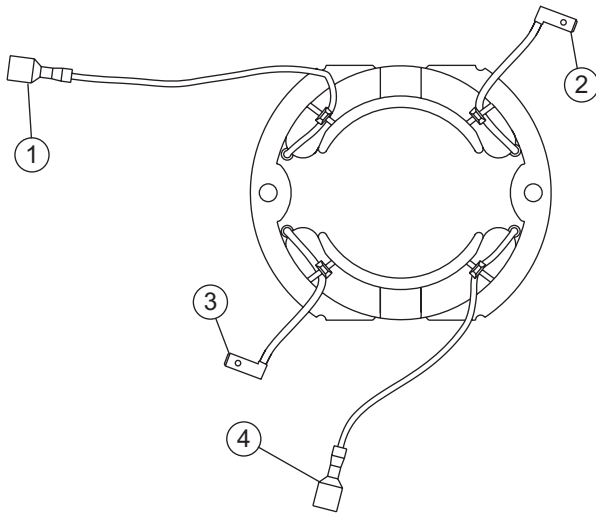

1. Lead to Switch
2. Lead to Brush Holder (Right Housing)
3. Lead to Brush Holder (Left Housing)
4. Lead to Switch

**Figure 9. Field Orientation**

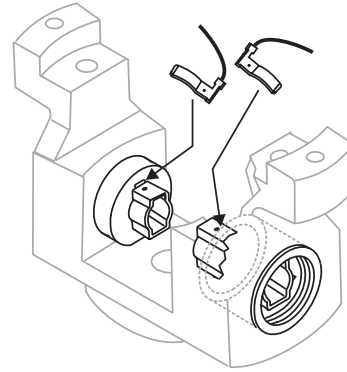

**Figure 10. Brush Leads**

10. Plug the Motor Power Leads (Items 5) to the spade terminals of the Power Switch Terminal (item 4) shown in Figure 11. Tuck the leads out of the way so they will not rub on the rotating armature assembly and to prevent them from getting pinched between the plastic housing halves.
11. Plug the Powercord Leads (items 3) to the Power Switch Terminal as shown in Figure 11.
12. Attach Ground Wire (item 2) from powercord to rear of brush endbell using screw and star washer.
13. Fit powercord into slot in housing half and place switch plate, filter and plastic filter cover into slot on housing half. Use illustration on page 20 for reference.
14. Assemble top plastic housing half (without the inserts) to the bottom plastic housing half and snap together. (the lip around the housing should "pop" as it aligns).
15. Install housing screws and lockwashers shown in illustration. Torque screws to 30-50 in-lbs, (3.39 N-m to 5.65 N-m).
16. Assemble the rubber TPR end caps and extruded tube handles onto plastic housing assembly using screws and washers shown in illustration.

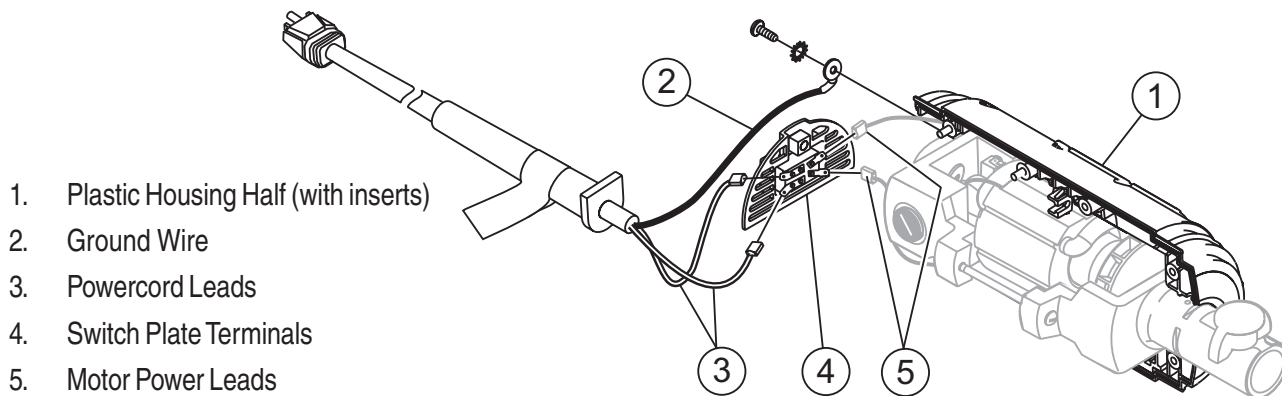

**Figure 11. Powercord hookup**

**TABLE 5. TROUBLESHOOTING**

SYMPTOM	POSSIBLE PROBLEM	SOLUTION
Motor does not start.	<p>No power to motor.</p> <p>Burnt out switch (rare). One or more internal connections open.</p>	<p>Verify unit is plugged in to proper outlet. Verify extension cords are properly plugged in and are not cut or pinched. Verify power is available at outlet. (check main switch or breaker.)</p> <p>Replace or complete connections as needed.</p>
Housing halves do not seat together properly	<p>Pinched wire.</p> <p>Switch Plate or Filter Cover not seated properly.</p> <p>Power Cord Grommet not seated properly.</p>	<p>Use screw driver to adjust wires. MAKE CERTAIN not to damage the insulation on the wires.</p> <p>Seat Switch Plate properly in Housing slot.</p> <p>Seat grommet in Housing slot.</p>
Rattling/growling noise from rear of housing area.	Rear bearing failure.	Replace bearing.
Rattling/growling noise from forward housing area.	<p>Worn coupler.</p> <p>Forward bearing failure.</p>	<p>Disconnect coupler and turn motor on. If noise goes away replace coupler. If noise remains, check forward bearing.</p> <p>Replace bearing.</p>

# CV-SERIES — VIBRATOR MOTOR HOUSING ASSY.

VIBRATOR MOTOR HOUSING ASSY.

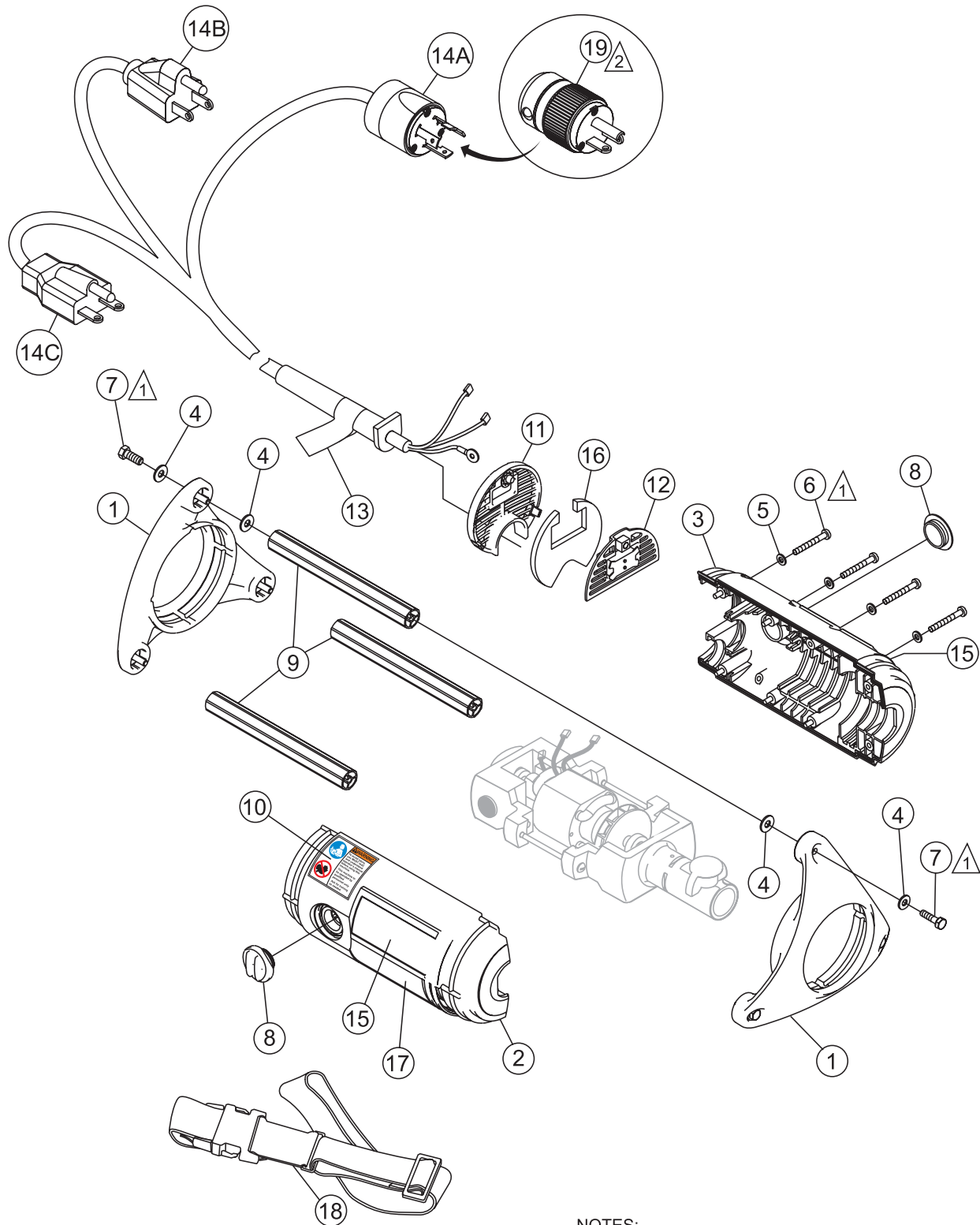

NOTES:

- △1 TORQUE TO 30-50 IN.-LBS. (3.39 N-m to 5.65 N-m)
- △2 OPTIONAL PLUG FOR CV3

## CV-SERIES — VIBRATOR MOTOR HOUSING ASSY.

### VIBRATOR MOTOR HOUSING ASSY.

<u>NO.</u>	<u>PART NO.</u>	<u>PART NAME</u>	<u>QTY.</u>	<u>REMARKS</u>
1	50125-03	END CAP, RUBBER	2	
2	50125-07	HOUSING, PLASTIC WITH INSERTS	1	
3	50125-08	HOUSING, PLASTIC WITHOUT INSERTS	1	
4	52003-04	WASHER, FLAT 1/4"	12	
5	52003-10	WASHER, LOCK M5	8	
6	53701-01	SCREW, PAN HEAD M5 X 40MM	8	
7	53701-02	SCREW, M6 X 1 X 16MM	6	
8	57001-04	CAP, BRUSH ACCESS	2	
9	65001-21	HANDLE TUBE EXTRUSION	3	
10	00100-46	DECAL, SAFETY .....	1	SAFETY ITEM
11	8200-002	COVER, PLASTIC FILTER ASSY.	1	
12	8200-003	SWITCH PLATE ASSY.	1	
13	00100-44	DECAL, WARNING .....	1	SAFETY ITEM
14A	8006-010	POWER CORD, 3HP 115V NEMA L5-20P .....	1	REPLACES 44000-08
14B	8006-011	POWER CORD, 1HP/2HP 115V NEMA 5-15P .....	1	REPLACES 44000-09
14C	8006-012	POWER CORD, 2HP/3HP 230V NEMA 6-15P .....	1	REPLACES 44000-10
15	00100-57	DECAL, CV-1 115V	2	
15	00100-59	DECAL, CV-2 115V	2	
15	00100-61	DECAL, CV-2 230V	2	
15	00100-62	DECAL, CV-3 115V	2	
15	00100-63	DECAL, CV-3 230V	2	
16	50000-03	AIR FILTER	1	
17		TAG, SERIAL NUMBER .....	1	CONTACT SALES DEPT.
18	CS-1	CARRYING STRAP .....	1	OPTIONAL EQUIPMENT
19	7196K34	PLUG W/O CORD 5-20P .....	1	CV3 ONLY, OPTIONAL

# CV-SERIES — VIBRATOR MOTOR ASSY.

## VIBRATOR MOTOR ASSY.

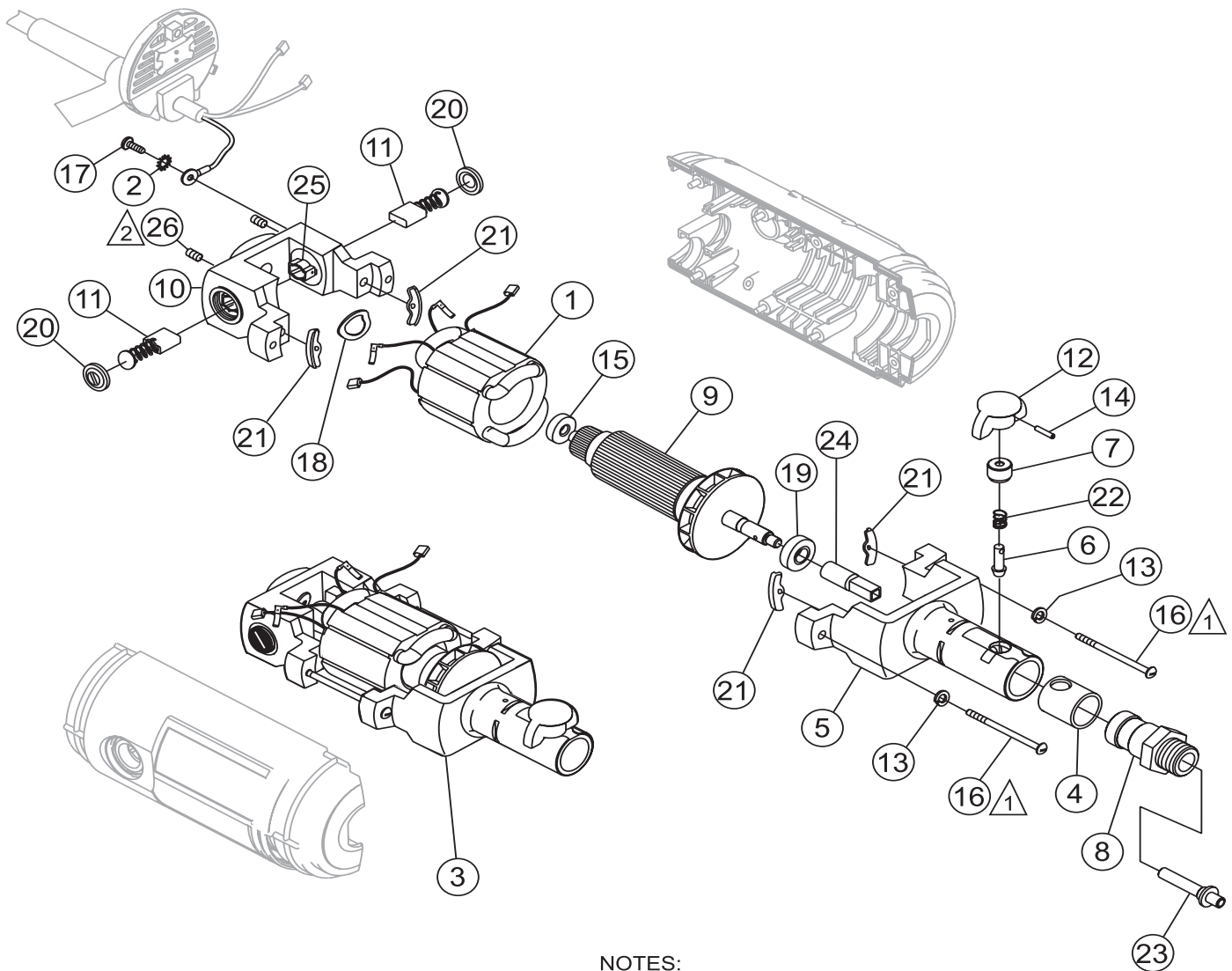

### NOTES:

- 1** TORQUE TO 50-70 IN.-LBS. (5.65 N-m to 7.91 N-m)
- 2** TORQUE TO 4-6 IN.-LBS. (.5 N-m to .7 N-m).  
TO REMOVE SET SCREW, USE A 3/32 ALLEN WRENCH.  
WHEN REPLACING SET SCREW, ADD 2-3 DROPS OF  
#680 LOCTITE (GREEN) IN SET SCREW HOLE.

## CV-SERIES — VIBRATOR MOTOR ASSY.

### VIBRATOR MOTOR ASSY.

<u>NO.</u>	<u>PART NO.</u>	<u>PART NAME</u>	<u>QTY.</u>	<u>REMARKS</u>
1	3061-045	FIELD ASSY, 1HP 115V CV-1	1	
1	3061-044	FIELD ASSY, 2HP 115V CV-2	1	
1	3061-047	FIELD ASSY, 2HP 230V CV-2	1	
1	3061-043	FIELD ASSY, 3HP 115V CV-3	1	
1	3061-046	FIELD ASSY, 3HP 230V CV-3	1	
2	52003-12	WASHER, STAR #10	2	
3	1000-060	MOTOR ASSY, 1HP 115V CV-1	1	
3	1000-061	MOTOR ASSY, 2HP 115V CV-2	1	
3	1000-062	MOTOR ASSY, 2HP 230V CV-2	1	
3	1000-063	MOTOR ASSY, 3HP 115V CV-3	1	
3	1000-064	MOTOR ASSY, 3HP 230V CV-3	1	
4	6100-003	BUSHING, BRONZE WEAR	1	
5	8100-015	END BELL ASSY, OUTPUT 1HP	1	
5	8100-016	END BELL ASSY, OUTPUT 2HP	1	
5	8100-017	END BELL ASSY, OUTPUT 3HP	1	
6	7200-001	LOCK PIN, QUICK DISCONNECT	1	
7	7200-002	HOUSING, SPRING	1	
8	7200-004	SHAFT COUPLING, QD 314V (CV-1)	1	
8	7200-003	SHAFT COUPLING, QD 382V (CV-2/2E-3/3E)	1	
9	8001-045	ARMATURE & BEARING ASSY, 1HP 115V CV-1	1	
9	8001-044	ARMATURE & BEARING ASSY, 2HP 115V CV-2	1	
9	8001-047	ARMATURE & BEARING ASSY, 2HP 230V CV-2	1	
9	8001-043	ARMATURE & BEARING ASSY, 3HP 115V CV-3	1	
9	8001-046	ARMATURE & BEARING ASSY, 3HP 230V CV-3	1	
10	8005-030	END BELL ASSY, COMM.	1	
11	43000-03	BRUSH ASSY, CARBON	2	
12	50125-04	KNOB, PLASTIC QUICK DISCONNECT	1	
13	52003-05	WASHER, LOCK #10	2	
14	53002-09	PIN, SLOTTED PIN 5/32 X 1	1	
15	55005-03	BEARING, REAR	1	
16	53001-14	SCREW, #10-32 X 4.00	2	
17	53101-04	SCREW, GROUND 10 - 32 X .375	1	
18	56000-06	WAVE SPRING	1	
19	55008-03	BEARING, FRONT	1	
20	57001-02	CAP, BRUSH	2	
21	59001-06	INSULATOR, PLASTIC FIELD	4	
22	59999-08	SPRING, COMPRESSION	1	
23	90004-03	SHAFT, SPINDLE 314V CV-1	1	
23	90004-01	SHAFT, SPINDLE 382V CV-2/2E-3/3E	1	
24	90004-02	DRIVE COUPLER, QUICK DISCONNECT	1	
25	57000-03	BRUSH HOLDER	2	
26	53051-01	BRUSH HOLDER SET SCREW #10-32 X .375	2	

**PAYMENT TERMS**

Terms of payment for parts are net 30 days.

**FREIGHT POLICY**

All parts orders will be shipped collect or prepaid with the charges added to the invoice. All shipments are F.O.B. point of origin. Multiquip's responsibility ceases when a signed manifest has been obtained from the carrier, and any claim for shortage or damage must be settled between the consignee and the carrier.

**MINIMUM ORDER**

The minimum charge for orders from Multiquip is \$15.00 net. Customers will be asked for instructions regarding handling of orders not meeting this requirement.

**RETURNED GOODS POLICY**

Return shipments will be accepted and credit will be allowed, subject to the following provisions:

1. A Returned Material Authorization must be approved by Multiquip prior to shipment.
2. To obtain a Return Material Authorization, a list must be provided to Multiquip Parts Sales that defines item numbers, quantities, and descriptions of the items to be returned.
  - a. The parts numbers and descriptions must match the current parts price list.
  - b. The list must be typed or computer generated.
  - c. The list must state the reason(s) for the return.
  - d. The list must reference the sales order(s) or invoice(s) under which the items were originally purchased.
  - e. The list must include the name and phone number of the person requesting the RMA.
3. A copy of the Return Material Authorization must accompany the return shipment.
4. Freight is at the sender's expense. All parts must be returned freight prepaid to Multiquip's designated receiving point.

5. Parts must be in new and resalable condition, in the original Multiquip package (if any), and with Multiquip part numbers clearly marked.
6. The following items are not returnable:
  - a. Obsolete parts. (If an item is in the price book and shows as being replaced by another item, it is obsolete.)
  - b. Any parts with a limited shelf life (such as gaskets, seals, "O" rings, and other rubber parts) that were purchased more than six months prior to the return date.
  - c. Any line item with an extended dealer net price of less than \$5.00.
  - d. Special order items.
  - e. Electrical components.
  - f. Paint, chemicals, and lubricants.
  - g. Decals and paper products.
  - h. Items purchased in kits.
7. The sender will be notified of any material received that is not acceptable.
8. Such material will be held for five working days from notification, pending instructions. If a reply is not received within five days, the material will be returned to the sender at his expense.
9. Credit on returned parts will be issued at dealer net price at time of the original purchase, less a 15% restocking charge.
10. In cases where an item is accepted, for which the original purchase document can not be determined, the price will be based on the list price that was effective twelve months prior to the RMA date.
11. Credit issued will be applied to future purchases only.

**PRICING AND REBATES**

Prices are subject to change without prior notice. Price changes are effective on a specific date and all orders received on or after that date will be billed at the revised price. Rebates for price declines and added charges for price increases will not be made for stock on hand at the time of any price change.

Multiquip reserves the right to quote and sell direct to Government agencies, and to Original Equipment Manufacturer accounts who use our products as integral parts of their own products.

**SPECIAL EXPEDITING SERVICE**

A \$35.00 surcharge will be added to the invoice for special handling including bus shipments, insured parcel post or in cases where Multiquip must personally deliver the parts to the carrier.

**LIMITATIONS OF SELLER'S LIABILITY**

Multiquip shall not be liable hereunder for damages in excess of the purchase price of the item with respect to which damages are claimed, and in no event shall Multiquip be liable for loss of profit or good will or for any other special, consequential or incidental damages.

**LIMITATION OF WARRANTIES**

No warranties, express or implied, are made in connection with the sale of parts or trade accessories nor as to any engine not manufactured by Multiquip. Such warranties made in connection with the sale of new, complete units are made exclusively by a statement of warranty packaged with such units, and Multiquip neither assumes nor authorizes any person to assume for it any other obligation or liability whatever in connection with the sale of its products. Apart from such written statement of warranty, there are no warranties, express, implied or statutory, which extend beyond the description of the products on the face hereof.



# OPERATION AND PARTS MANUAL

## HERE'S HOW TO GET HELP

PLEASE HAVE THE MODEL AND SERIAL  
NUMBER *ON-HAND* WHEN CALLING

### UNITED STATES

#### ***Multiquip Corporate Office***

18910 Wilmington Ave. Tel. (800) 421-1244  
Carson, CA 90746 Fax (800) 537-3927  
Contact: mq@multiquip.com

#### ***Mayco Parts***

800-306-2926 Fax: 800-672-7877  
310-537-3700 Fax: 310-637-3284

#### ***Service Department***

800-421-1244 Fax: 310-537-4259  
310-537-3700

#### ***MQ Parts Department***

800-427-1244 Fax: 800-672-7877  
310-537-3700 Fax: 310-637-3284

#### ***Warranty Department***

800-421-1244, Ext. 279 Fax: 310-537-1173  
310-537-3700, Ext. 279

#### ***Technical Assistance***

800-478-1244 Fax: 310-631-5032

### MEXICO

#### ***MQ Cipsa***

Carr. Fed. Mexico-Puebla KM 126.5 Tel: (52) 222-225-9900  
Momoxpan, Cholula, Puebla 72760 Mexico Fax: (52) 222-285-0420  
Contact: pmastretta@cipsa.com.mx

### CANADA

#### ***Multiquip***

4110 Industriel Boul. Tel: (450) 625-2244  
Laval, Quebec, Canada H7L 6V3 Fax: (450) 625-8664  
Contact: jmartin@multiquip.com

### UNITED KINGDOM

#### ***Multiquip (UK) Limited Head Office***

Hanover Mill, Fitzroy Street, Tel: 0161 339 2223  
Ashton-under-Lyne, Fax: 0161 339 3226  
Lancashire OL7 0TL  
Contact: sales@multiquip.co.uk

### BRAZIL

#### ***Multiquip***

Av. Evandro Lins e Silva, 840 - grupo 505 Tel: 011-55-21-3433-9055  
Barra de Tijuca - Rio de Janeiro Fax: 011-55-21-3433-9055  
Contact: cnavarro@multiquip.com.br, srentes@multiquip.com.br

© COPYRIGHT 2007, MULTIQUIP INC.

Multiquip Inc and the MQ logo are registered trademarks of Multiquip Inc. and may not be used, reproduced, or altered without written permission. All other trademarks are the property of their respective owners and used with permission.

This manual MUST accompany the equipment at all times. This manual is considered a permanent part of the equipment and should remain with the unit if resold.

The information and specifications included in this publication were in effect at the time of approval for printing. Illustrations are based on the *CV Series Vibrator Motor*. Illustrations, descriptions, references and technical data contained in this manual are for guidance only and may not be considered as binding. Multiquip Inc. reserves the right to discontinue or change specifications, design or the information published in this publication at any time without notice and without incurring any obligations.

Your Local Dealer is:

