

# OPERATION AND PARTS MANUAL



## **MODEL MQ41TDH DIESEL POWERED TRASH PUMP (HATZ 1D81Z DIESEL ENGINE)**

Revision #3 (04/02/07)

To find the latest revision of this  
publication, visit our website at:  
[www.multiquip.com](http://www.multiquip.com)



**THIS MANUAL MUST ACCOMPANY THE EQUIPMENT AT ALL TIMES.**



**WARNING**



**CALIFORNIA — Proposition 65 Warning**

**Diesel engine exhaust and some of its constituents are known to the State of California to cause cancer, birth defects and other reproductive harm.**



# TRAINING CHECKLIST

## TRAINING CHECKLIST

This checklist will lists some of the minimum requirements for machine maintenance and operation. Please detach it and make copies. Use this checklist whenever a new operator is to be trained or it can be used as a review for more experienced operator's.

TRAINING CHECKLIST			
NO.	DESCRIPTION	OK?	DATE
1	Read Operator's Manual completely.		
2	Machine layout, location of components, checking of engine and oil levels.		
3	Fuel system, refueling procedure.		
4	Pump priming procedure.		
5	Emergency stop procedures.		
6	Engine start-up procedure.		
7	Lifting of machine (lift loops)		
8	Pump applications (lift, uses etc.)		
9	Suction strainer placement.		
10	Hose connections.		
11	Pump placement.		
12	Trailer safety guidelines.		
13	Protective clothing guidelines.		
14	Vacuum test procedure.		
15	Machine transport and storage.		
16	Clean out pump cavity procedure.		

Operator \_\_\_\_\_ Trainee \_\_\_\_\_

COMMENTS:



# DAILY PRE-OPERATION CHECKLIST

## DAILY PRE-OPERATION CHECKLIST

DAILY PRE-OPERATION CHECKLIST	
1	Check engine oil level.
2	Check fuel level (and for clean fuel).
3	Check cooling fins and cooling air flow.
4	Check engine air cleaner blockage indicator.
5	Check engine air cleaner.
6	Check engine battery and cable connections.
7	Check pump volute.
8	Check pump impeller.
9	Check pump seal.
10	Check pump casing for cracks.
11	Check trailer wheel lug nuts for tightness.
12	Check trailer wheel bearings.
13	Check trailer hitch and ball.
14	Check trailer springs and hardware (jack stand).
15	Check trailer tire pressure.
16	Check trailer lights.

COMMENTS:

Proposition 65 Warning .....	2
Training Checklist .....	4
Daily Pre-Operation Checklist .....	5
Table Of Contents .....	6
Parts Ordering Procedures .....	7
Rules For Safe Operation .....	8-9
Operation and Safety Decals .....	10
Specifications .....	11
Components .....	12
General Information .....	13

## Multiquip MQ41TDH — Diesel Powered Trash Pump

Application .....	14
Pre-Setup (Pump) .....	15
Initial Start-Up (Engine) .....	16-18
Maintenance .....	19-22
Preparation For Long Term Storage .....	23
Troubleshooting (Pump) .....	24
Troubleshooting (Engine) .....	25-26
Explanation Of Codes In Remarks Column .....	28
Suggested Spare Parts .....	29
Name Plate And Decals .....	30-31
Pump Assy. ....	32-35
Skid Assy. ....	36-37
Trailer-10 Assy. ....	38-39
Trailer-1 Kit Assy. ....	40-41
Whl-2 Kit Assy. ....	42-43
TNKZZ Assy. (Optional Fuel Tank) .....	44-45

## Hatz 1D81Z Diesel Engine

Crankcase Assembly .....	46-47
Crankcase Assembly (External Parts) .....	48-49
Crankshaft Assembly .....	50-51
Camshaft Assembly .....	52-53
Piston/Rings Assembly .....	54-55
Cylinder Head Assembly .....	56-59
Flywheel Assembly .....	60-61
Oil Pump Assembly .....	62-63
Timing Cover Assembly .....	64-65
Fuel Device .....	66-67
Air Ducting Assembly .....	68-69
Breather Assembly .....	70-71
Fuel Tank Assembly .....	72-73
Fuel Pump Assembly .....	74-75
Air Filter Assembly .....	76-77
Exhaust Silencer .....	78-79
Starter/Alternator Assembly .....	80-81
Instrument Box Assembly .....	82-83
Lifting Magnet/Stop Device .....	84-85
Terms and Conditions Of Sale — Parts .....	86

### NOTE

*Specification and part number  
are subject to change without  
notice.*

www.multiquip.com

**Ordering parts has never been easier!  
Choose from three easy options:**



**Order via Internet (Dealers Only):**

Order parts on-line using Multiquip's SmartEquip website!

- View Parts Diagrams
- Order Parts
- Print Specification Information



If you have an MQ Account, to obtain a Username and Password, E-mail us at: [parts@multiquip.com](mailto:parts@multiquip.com).

To obtain an MQ Account, contact your District Sales Manager for more information.

Goto [www.multiquip.com](http://www.multiquip.com) and click on **Order Parts** to log in and save!

Use the **internet** and qualify for a **5% Discount** on *Standard orders* for all orders which include complete part numbers.\*

Note: Discounts Are Subject To Change



**Order via Fax (Dealers Only):**

All customers are welcome to order parts via Fax.

**Domestic (US) Customers dial:**  
1-800-6-PARTS-7 (800-672-7877)

**Fax** your order in and qualify for a **2% Discount** on *Standard orders* for all orders which include complete part numbers.\*

Note: Discounts Are Subject To Change



**Order via Phone: Domestic (US) Dealers Call:**  
1-800-427-1244

**Non-Dealer Customers:**

Contact your local Multiquip Dealer for parts or call 800-427-1244 for help in locating a dealer near you.



**International Customers** should contact their local Multiquip Representatives for Parts Ordering information.

**When ordering parts, please supply:**

- |  |  |
|--|--|
| <ul style="list-style-type: none"> <li><input type="checkbox"/> Dealer Account Number</li> <li><input type="checkbox"/> Dealer Name and Address</li> <li><input type="checkbox"/> Shipping Address (if different than billing address)</li> <li><input type="checkbox"/> Return Fax Number</li> <li><input type="checkbox"/> Applicable Model Number</li> <li><input type="checkbox"/> Quantity, Part Number and Description of Each Part</li> </ul> | <ul style="list-style-type: none"> <li><input type="checkbox"/> Specify Preferred Method of Shipment:           <ul style="list-style-type: none"> <li><input checked="" type="checkbox"/> UPS/Fed Ex      <input checked="" type="checkbox"/> DHL</li> <li><input type="checkbox"/> Priority One      <input checked="" type="checkbox"/> Truck</li> <li><input type="checkbox"/> Ground</li> <li><input type="checkbox"/> Next Day</li> <li><input type="checkbox"/> Second/Third Day</li> </ul> </li> </ul> |
|--|--|

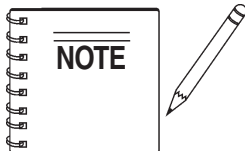

All orders are treated as *Standard Orders* and will ship the same day if received prior to 3PM PST.

**WE ACCEPT ALL MAJOR CREDIT CARDS!**



# RULES FOR SAFE OPERATION

## CAUTION:



Failure to follow instructions in this manual may lead to serious injury or even death! This equipment is to be operated by trained and qualified personnel only! This equipment is for industrial use only.

The following safety guidelines should always be used when operating the MQ41TDH Trash Pump:

### GENERAL SAFETY

- **DO NOT** operate or service this equipment before reading this entire manual.



- This equipment should not be operated by persons under 18 years of age.

- **NEVER** operate this equipment without proper protective clothing, shatterproof glasses, steel-toed boots and other protective devices required by the job.



- **NEVER** operate this equipment when not feeling well due to fatigue, illness or taking medicine.



- **NEVER** operate this equipment under the influence of drugs or alcohol.



- **NEVER** use accessories or attachments, which are not recommended by Multiquip for this equipment. Damage to the equipment and/or injury to user may result.

- Manufacture does not assume responsibility for any accident due to equipment modifications.

- Whenever necessary, replace nameplate, operation and safety decals when they become difficult to read.

- Always check the machine for loosened threads or bolts before starting.

- **NEVER** touch the hot exhaust manifold, muffler or cylinder. Allow these parts to cool before servicing engine or pump.



- **High Temperatures** – Allow the engine to cool before adding fuel or performing service and maintenance functions. Contact with *hot* components can cause serious burns.

- The air-cooled diesel engine of this pump requires an adequate free flow of cooling air. Never operate the pump in any enclosed or narrow area where free flow of the air is restricted. If the air flow is restricted it will cause serious damage to the pump or engine and may cause injury to people and property. Remember the pump's diesel engine gives off **DEADLY** gases.

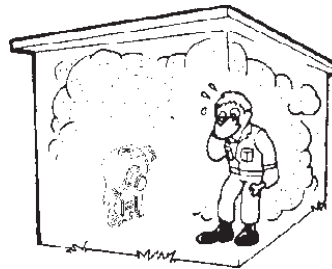

- Always refuel in a well-ventilated area, away from sparks and open flames.



- Always use extreme caution when working with **flammable** liquids. When refueling, **stop the engine** and allow it to cool. **DO NOT** smoke around or near the machine. Fire or explosion could result from fuel vapors, or if fuel is spilled on a hot engine.

- **NEVER** operate the pump/engine in an explosive atmosphere or near combustible materials. An explosion or fire could result causing severe *bodily harm or even death*.

- Topping-off to filler port is dangerous, as it tends to spill fuel.

## RULES FOR SAFE OPERATION

- **NEVER** use accessories or attachments, which are not recommended by Multiquip for this equipment. Damage to the equipment and/or injury to user may result.
- **NEVER** pump volatile, flammable or low flash point fluids. These fluids could ignite or explode.
- **NEVER** pump corrosive chemicals or water containing toxic substances. These fluids could create serious health and environmental hazards. Contact local authorities for assistance.
- **NEVER** open the priming plug when pump is hot. Hot water inside could be pressurized much like the radiator of an automobile. Allow pump to cool to the touch before loosening plug.
- **NEVER** open the pump housing during operation or start the pump with the cover off. The rotating impeller inside the pump can cut or sever objects caught in it.
- **NEVER** block or restrict flow from discharge hose. Remove kinks from discharge line before starting pump. Operation with a blocked discharge line can cause water inside pump to overheat.
- **NEVER** Run engine without air cleaner. Severe engine damage may occur.
- Check the **air cleaner blockage indicator** daily. If the rubber bellows is pulled inwards this indicates restricted air flow, replace air cleaner.
- Always read, understand, and follow procedures in **Hatz Engine Operator's Manual** before attempting to operate equipment.
- Always be sure the operator is familiar with proper safety precautions and operations techniques before using pump.
- Always store equipment properly when it is not being used. Equipment should be stored in a clean, dry location out of the reach of children.
- Refer to the **Hatz Engine Owner's Manual** for engine technical questions or information.
- Always fill the pump casing with water before starting the engine. Failure to maintain water inside the pump housing will cause severe damage to the pump.
- In winter drain water from pump housing to prevent freezing.
- Always make sure pump is correctly secured to the trailer. Check all supports attaching the pump to the trailer and make sure they are tight.
- Always make sure that the pump's trailer is placed on solid level ground so that it cannot slide or shift around, endangering workers. Place blocks under the trailer's bumper to make it level (prevents tipping), and use a chocked block underneath the wheels to prevent rolling. Also keep the immediate area free of bystanders.
- **High Temperatures** – Allow the engine to cool before adding fuel or performing service and maintenance functions. Contact with *hot* components can cause serious burns.

### Emergencies

- Always know the location of the nearest **fire extinguisher** and **first aid kit**. Know the location of the nearest telephone. Also know the phone numbers of the nearest **ambulance, doctor** and **fire department**. This information will be invaluable in the case of an emergency.

### Maintenance Safety

- **NEVER** lubricate components or attempt service on a running machine.
- Always allow the machine a proper amount of time to cool before servicing.
- Keep the machinery in proper running condition.
- Fix damage to the machine immediately and always replace broken parts.
- Dispose of hazardous waste properly. Examples of potentially hazardous waste are used motor oil, fuel and fuel filters.
- **DO NOT** use food or plastic containers to dispose of hazardous waste.
- **DO NOT** pour waste, oil or fuel directly onto the ground, down a drain or into any water source.

# OPERATION AND SAFETY DECALS

## Machine Safety Decals

The MQ41TDH Centrifugal Trash pump is equipped with a number of safety decals. These decals are provided for operator safety and maintenance information. The illustration below shows these decals as they appear on the machine. If any of these decals become unreadable, replacements can be obtained from your dealer.



P/N 5349

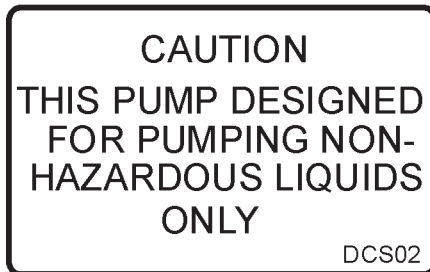

P/N DCS02

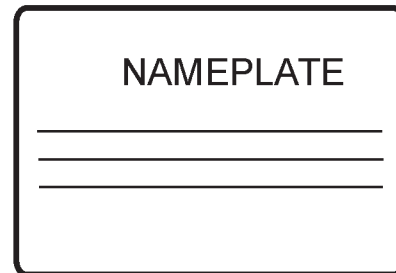

P/N CONTACT MULTIQUIP  
SERVICE DEPT.

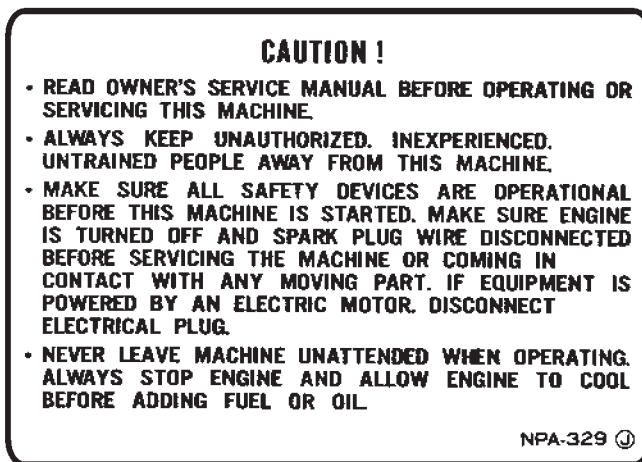

P/N 920203290



P/N 7005000

**TABLE 1. Engine Specifications**

Engine Make	HATZ
Engine Model	1D81Z
Engine Type	Air Cooled 4-Stroke Diesel
Number Of Cylinders	1
Bore/Stroke	88/85 mm
Combustion Method	Direct Fuel Injection
Oil Grade	See Table 3, pg 17
Oil Capacity	.5 gal/1.9 liters
Fuel Type	Diesel
Fuel Tank Capacity	1.85 gal/7.0 liters
Weight	91 kg/201 lbs
Starting Method	Electric Start

**TABLE 2. Pump Specifications**

Maximum Pumping Capacity	611 gpm (2, 313 lpm)
Maximum Suction Lift*	25 FT. (7.6 meters)
Maximum Total Head	90 FT. (27 meters)
Maximum Pressure	38.96 psi
Maximum Solids	2 in. (50 mm)
Suction and Discharge Diameter	4 in. (101 mm)
Dimensions (LxWxH)	48 x 36 x 46 in. (122 x 91 x142 cm)
Weight	200 lbs (90 kg.)

\* Based on pump operating at sea level. Maximum suction lift will be less at higher altitudes.

## SOUND MEASUREMENTS

The required sound specifications, per Appendix 1, paragraph 1.7.4.f of the EC-Machine Regulations, are defined as follows:

The sound pressure level at the operator's location (L) = 87 dB (A)

The sound power level (L) = 97 dB (A)

These sound values are determine according to ISO 3744 for the sound power level (L) and ISO 6081 for the sound pressure level (L) at the operator's location.

The sound measurements were obtained with the unit operation on pavement at nominal speed.

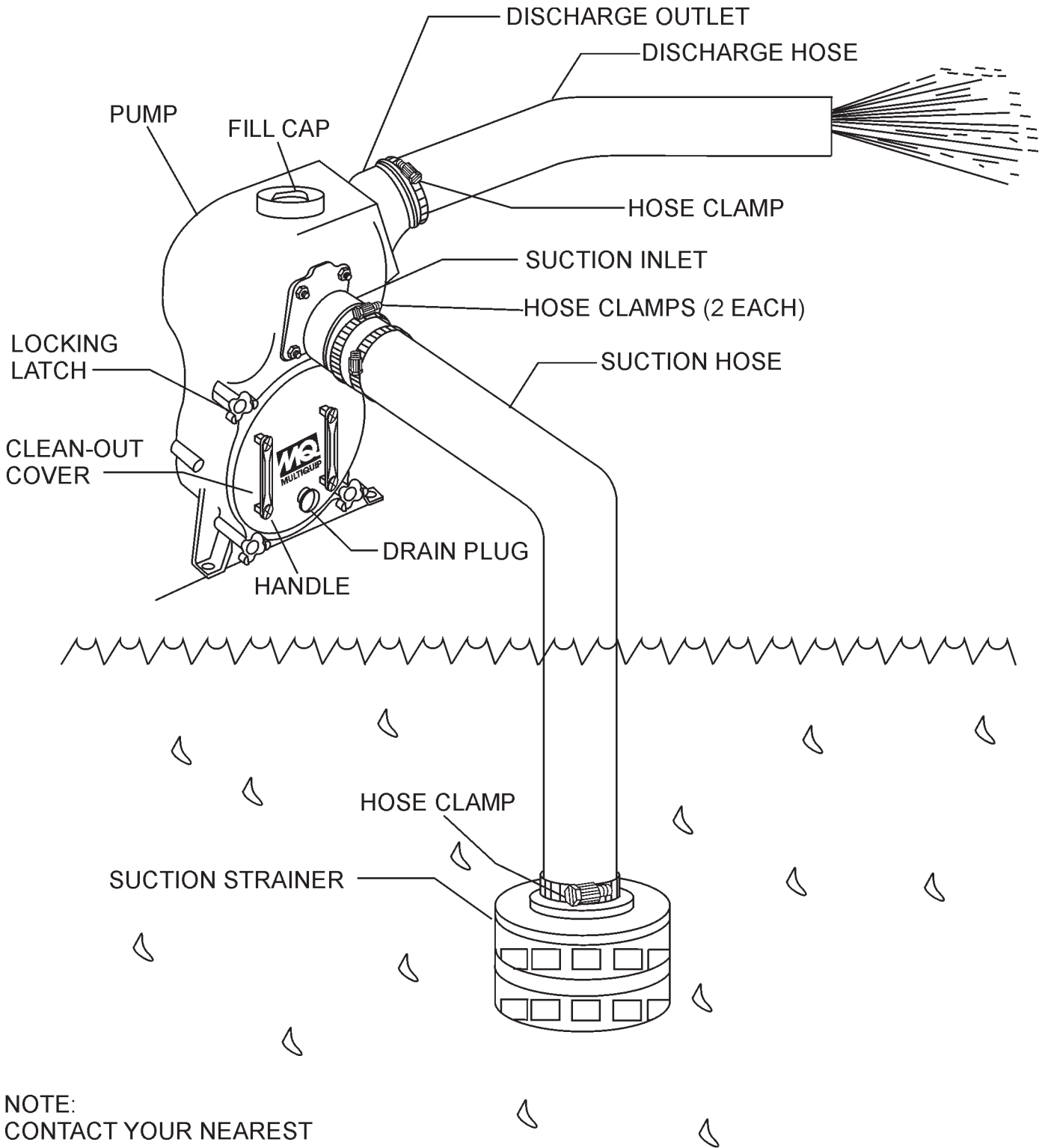

NOTE:  
CONTACT YOUR NEAREST  
MULTIQUIP DEALER FOR  
QUICK DISCONNECT HOSES  
AND FITTINGS.

**Figure 1. Pump Components**

The MQ41TDH Trash Pump is a self-priming centrifugal trash pump powered by a 15 horsepower air-cooled four stroke HATZ diesel engine. Both the intake (suction) and discharge ports on the MQ41TDH incorporate a 4-inch diameter opening, which allows the pump to pump at a rate of approximately 611 gpm or 2,313 lpm.

## Trash Pump

Trash pumps derive their name from their ability to handle a greater amount of debris and solids than standard centrifugal pumps. These pumps generally handle solids up to 1/2 the size of the discharge opening making them less likely to clog. Also trash pumps are capable of handling water with 25% solids by weight.

The advantage of using a trash pump is that it can be quickly and easily disassembled in the field to remove debris in the event the pump becomes clogged.

## Suction Lift

This pump is intended to be used for dewatering applications and is capable of suction lifts up to 25 feet at sea level. For optimal suction lift performance keep the suction hose or line as short as possible. In general always put the pump as close to the water as possible.

## Pump Support

The pump should always be placed on solid stationary ground in a level position. To prevent the trailer from tipping, place blocks under the trailer's bumper. In addition, place chock blocks behind each wheel to prevent the trailer from rolling.

**NEVER** place the pump on **soft soil**. The suction hose or pipe connection should always be checked for tightness and leaks. A small suction leak in the hose or fittings could prevent the pump from priming.

## Elevation

Elevations over 3,000 feet will effect the performance of the pump. Due to less atmospheric pressure at higher altitudes, pumps **DO NOT** have the priming ability that they have at sea level.

A general rule of thumb is that for every 1,000 feet of elevation above sea level a pump will lose one foot of priming ability.

For example, in Flagstaff, Arizona where the elevation is approximately 7,000 feet, the pump would have a suction lift of only 18 feet rather than the 25 feet at sea level.

## Pump Clean-out

The clean-out cover on the MQ41TDH has been design for easy removal that allows for easy access to the volute and impeller for cleaning and servicing.

## Spark Arresters

State Health Safety Codes and Public Resources Codes specify that in certain locations spark arresters be used on internal combustion engines that use hydrocarbon fuels. A spark arrester is a device designed to prevent accidental discharge of sparks or flames from the engine exhaust. Spark arresters are qualified and rated by the United States Forest Service for this purpose.

In order to comply with local laws regarding spark arresters, consult the engine distributor or the local Health and Safety Administrator.

## Mechanical Seal Lubrication

The pump uses a water-cooled mechanical seal to prevent water from seeping into the engine. The passage of water through the pump casing lubricates the seal and prevents it from overheating. Never operate the pump without water in the casing as this will cause the seal to fail.

## Engine Safety

Internal combustion engines present special hazards during operation and fueling! Failure to follow the safety guidelines described in the Rules for Safe Operation section of this manual and the Hatz Engine Operator's Manual could result in severe injury or death.

## Accessories

Multiquip offers a complete line of fittings, hoses, and clamps to properly connect the pump to match various job conditions. Refer to the part list in section 2 of this manual for a complete list of accessories

# MQ41TDH — APPLICATION

Figure 2 below shows a typical application using the MQ41TH Centrifugal Trash pump. Please note that this pump is intended for the removal of clean water and water containing some debris and solids. Maximum size of solids should not exceed 2 inches (50 mm) in diameter. **DO NOT** set strainer on bottom of water bed. Placing the strainer above the water bed will prevent the pump from drawing in excessive amounts of sand and foreign debris.

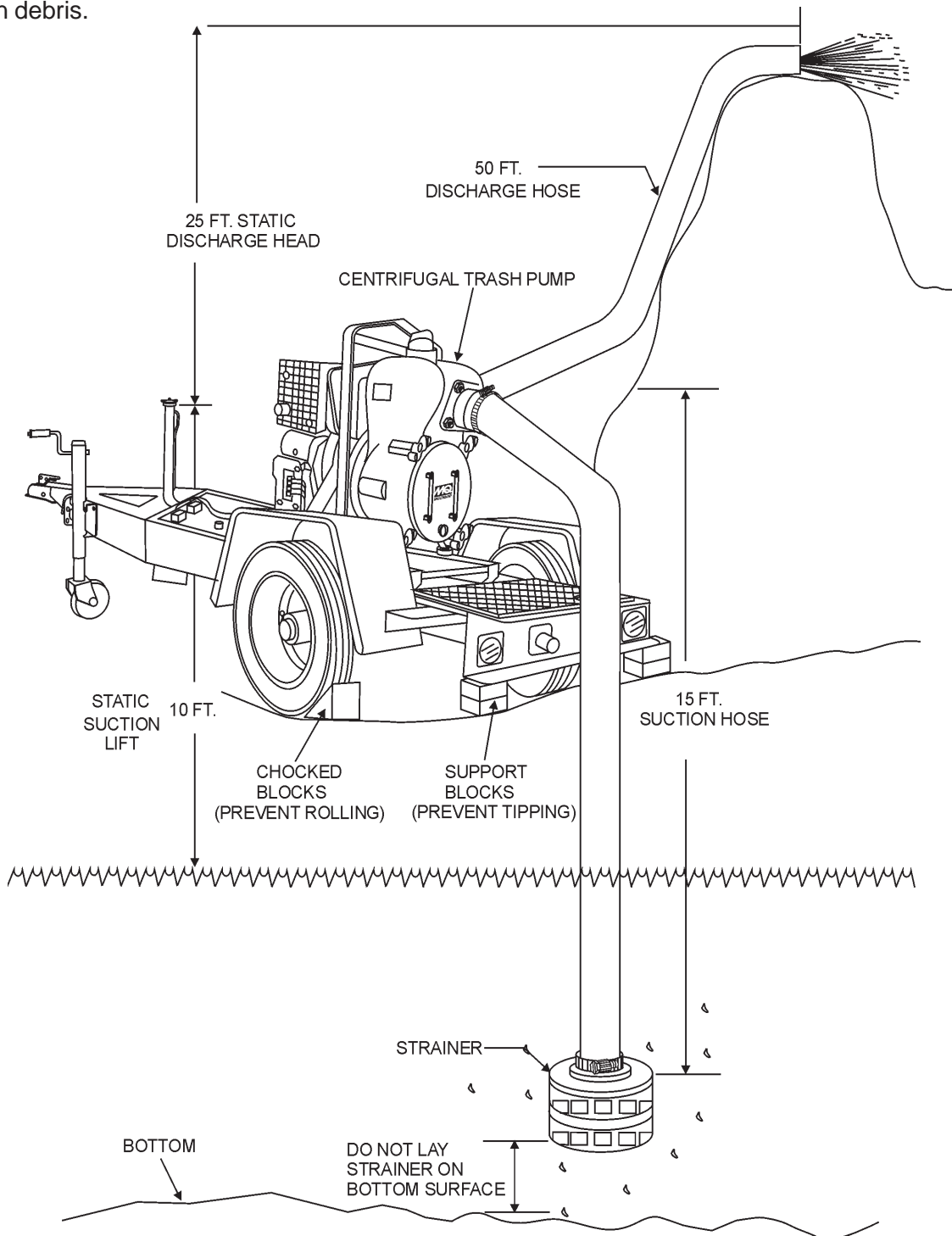

Figure 2. Pump Application

## Before Starting

1. Read safety instructions at the beginning of manual.
2. Place pump as near to water as possible, on a firm flat, level surface.
3. To prime pump, remove fill cap (Figure 1) and fill pump case with water. If the pump case is not filled with water before starting, it will not begin pumping.

### NOTE

Pump case **must** be filled with water before using pump. Otherwise pump will not be able to begin pumping.

### WARNING



**DO NOT** open fill cap if pump is **hot!** Water inside may be under pressure.

4. Check for **leaks** between pump and engine. If water is leaking between the pump and engine housing, the seal inside the pump may be worn or damaged. Continued operation of the pump is not recommended. Further usage of the pump under these conditions may cause severe water damage to engine.

## Hoses and Clamps

1. Check that all hoses are **securely** attached to the pump. Make certain suction hose (Figure 1) does not have any air leakage. Tighten hose clamps and couplings as required.
2. It is recommended that 2 clamps be used when securing the suction hose to the inlet side of the pump.
3. Remember suction hoses must be **rigid** enough not to collapse when the pump is in operation.
4. Check that the **discharge** hose (Figure 1) is not restricted. Place hose so that it lays as straight as it is possible on the ground. Remove any twists or sharp bends from hose which may block the flow of water.

### NOTE

Suction and discharge hoses are available from Multiquip. Contact your nearest dealer for more information.

5. The discharge hose is usually a **collapsible** (thin-walled) hose, however if a thin-walled discharge hose is not available, a rigid suction hose can be substituted in its place.
6. Make sure the **suction strainer** (Figure 1) is clean and securely attached to the water end of the suction hose. The strainer is designed to protect the pump by preventing large objects from being pulled into the pump.

### CAUTION:



The strainer should be positioned so it will remain completely **under water**. Running the pump with the strainer above water for long periods can damage the pump.

### CAUTION:



**DO NOT** pump flammable fluids, corrosive chemicals or fluids containing toxic substances. These fluids can create potentially dangerous health and environmental hazards. Contact local authorities for assistance.

# MQ41TDH — INITIAL START-UP (ENGINE)

## CAUTION :



**DO NOT** attempt to start the engine unless the pump has previously been **primed** with water. Severe pump damage will occur if pump has not been primed.

### Engine Oil

1. Make sure pump/engine is on level ground.
2. Pull the engine oil dipstick (Figure 3) from its holder.

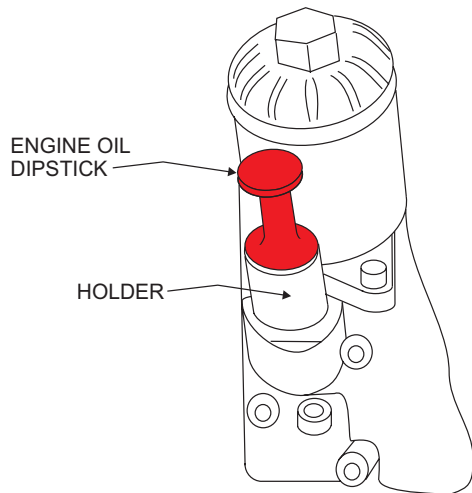

**Figure 3. Dipstick Location**

3. Verify that oil level (Figure 4) is maintained between the two notches on the dipstick.

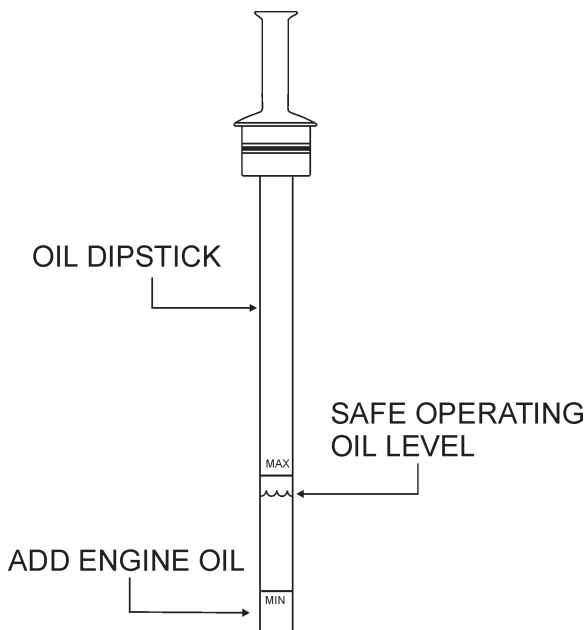

**Figure 4. Engine Oil Dipstick**

4. If engine oil is low, fill engine crankcase with lubricating oil through filler hole (Figure 3), but do not overfill.
5. The oil listed in Table 3 is recommended to ensure better engine performance. Use class CD or higher grade motor oil.

**Table 3. Oil Selection Chart**

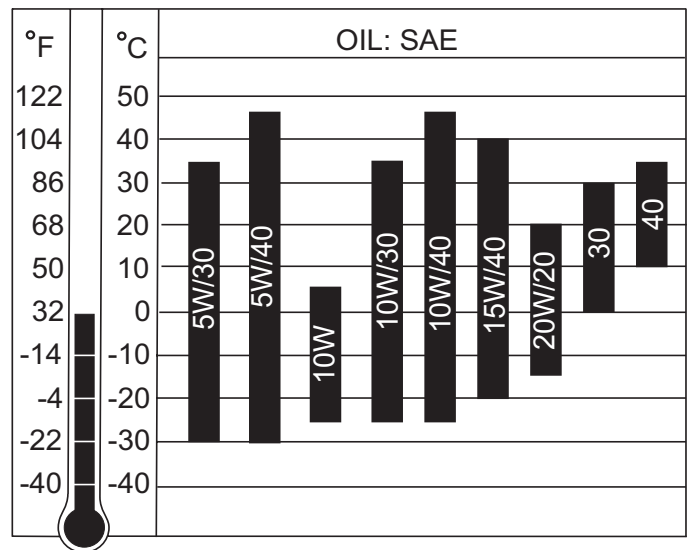

## Fuel

### CAUTION :



Never fill the fuel tank while the engine is running or in the dark. Fuel spillage on a hot engine can cause a fire or explosion. If fuel spillage occurs, wipe up the spilled fuel completely to prevent fire hazards.

1. Determine if engine fuel is low by removing fuel cap and looking inside tank. Fill with diesel fuel. **DO NOT** fill the tank beyond capacity.

### CAUTION :



**DO NOT** smoke while refueling, motor fuels are highly flammable and can be dangerous if mishandled.

2. Handle fuel in a safety container. If the container does not have a spout use a funnel.
3. Pay attention to the fuel tank capacity when replenishing fuel. Refer to the fuel tank capacity listed on page 11, Specification Table 1.
4. Tighten fuel tank cap securely after filling.

## Speed Control Lever

1. Set the **Speed Control Lever** (Figure 5) to a position half way between start and stop.

### NOTE

Selecting a **lower** engine speed will reduce smoke when starting.

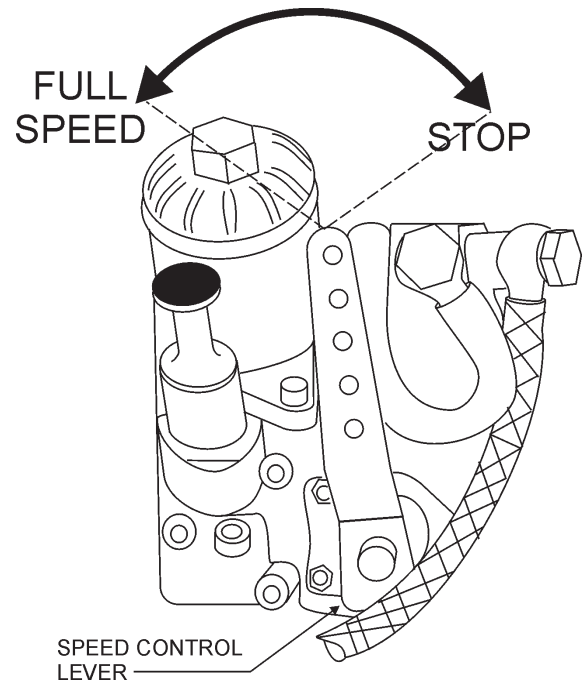

**Figure 5. Speed Control Lever**

# MQ41TDH — INITIAL START-UP (ENGINE)

## Control Box

1. Insert ignition key into ignition switch located on control box (Figure 6)

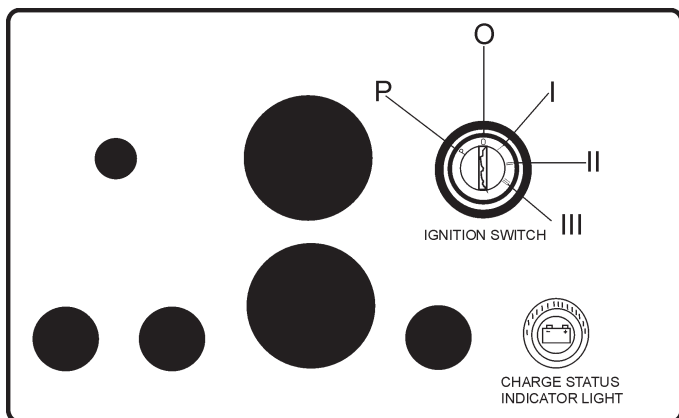

Figure 6. Control Box

2. Turn ignition key to position I, and verify that charge indicator light comes **ON**.
3. Continue turning the ignition key through positions II and III.
4. Release ignition key as soon as engine starts, and verify that ignition key automatically returns back to position I.
5. Verify charge indicator light goes **OFF** immediately when engine is started.
6. If charge indicator remains lit, increase engine speed until light goes off. When the charge indicator light goes off, it can then be assumed that the charging system is working correctly .
7. If the charge light remains on while the engine is running, refer to engine troubleshooting guide (pages 25-26) or the **Hatz EngineInstructionManual**.
8. Move **speed control lever** to full start position for maximum engine speed. (See Fig. 5)

## Operation

1. The MQ41TDH trash pump should begin pumping water within a minute depending on the length of suction hose and height the pump is above water.

### NOTE

Longer suction hoses will require more time for the pump to begin pumping water.

2. If pump does not begin to pump water after a few minutes, check for loose connections or air leaks in suction hose. Make sure there is water in the pump end and strainer is not clogged with debris, reference pump troubleshooting guide on page 25.

## Engine Shut-Down

1. Slow down the engine and allow to cool for at least 2 minutes. Place **speed control lever** in the stop position and listen for the engine to stop running.

## CAUTION :



**NEVER** attempt to stop the engine by moving the decompression lever. Always use the speed control lever to stop engine.

2. Turn the ignition key to the **0** position and remove the key from the ignition switch.

## CAUTION :



When pump is not in use, keep ignition starting key in a safe place, out of the reach of unauthorized persons.

## General Inspection

The following maintenance guidelines are intended to assist the operator in preventative maintenance. For a more detailed maintenance schedule refer to the **Hatz Engine Instruction Manual** supplied with the pump.

At least **daily** or prior to each use, the MQ41TDH trash pump cover should be removed, and the pump should be cleaned and inspected for deficiencies. Check for loose, missing or damaged nuts, bolts or other fasteners. Also check for fuel or oil leaks, and remove any debris stuck in the impeller or volute.

## Check Oil Level

Check the engine crankcase oil level prior to each use, or when the fuel tank is filled. Make sure the pump is level. The oil level must be between the two notches on the dipstick as shown in Figure 7.

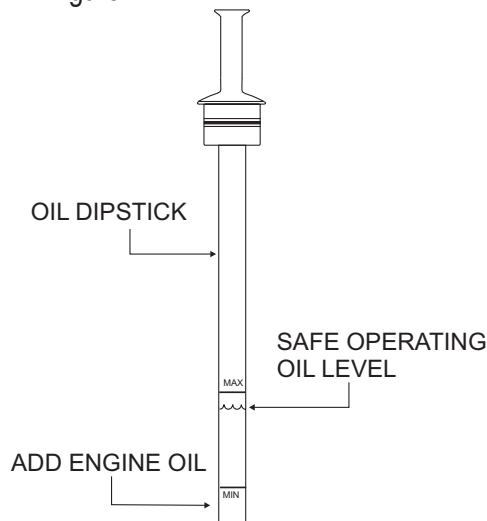

**Figure 7. Engine Oil Dipstick**

## Changing Engine Oil

Change engine oil after first 25 hours of operation. Drain and refill engine crankcase with the correct type and amount oil (reference Table 3) after 250 hours of operation hours or once a week thereafter.

When draining engine crankcase oil, place oil into a suitable container while engine is still warm. Replace the drain plug tightly. Add oil through the filler hole.

## Changing Oil Filter

Change the engine oil filter (Figure 8) and gasket after 250 hours of operation. To gain access to the oil filter element, unscrew the oil filter cap and replace the oil filter element. Make sure to tighten oil filter cap securely.

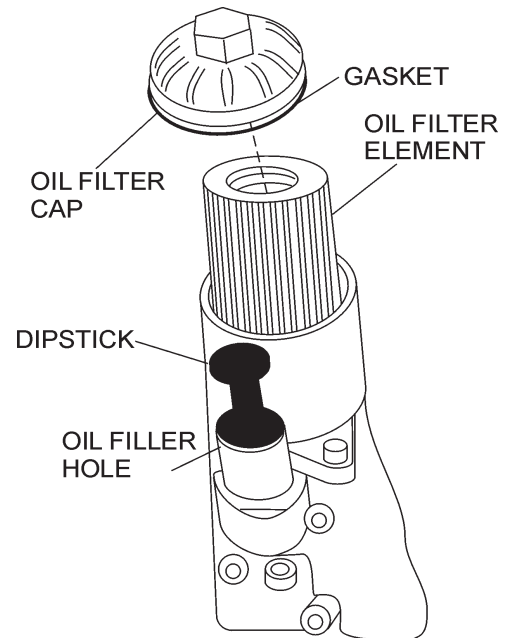

**Figure 8. Oil Filter Element**

## Fuel Filter

Replace fuel filter (Figure 9) and drain fuel tank to remove water and sediment every 500 hours. If the purity of the fuel being used is of lesser quality replace fuel filter more often as needed.

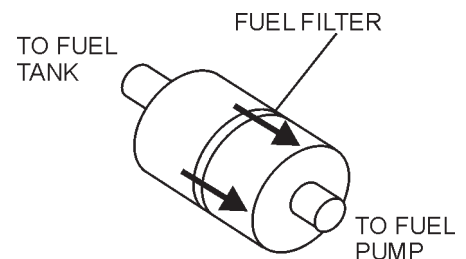

**Figure 9. Fuel Filter**

### NOTE

When re-installing fuel filter, please note the arrows indicating the direction of fuel flow.

## Air Filter Blockage Indicator

To test the air cleaner blockage indicator (Figure 10) run the engine at full speed for a short time. If the rubber bellows is pulled inwards (down), and the green rubber band cannot be seen, this implies that maintenance work is required on the air cleaner. Clean or replace air cleaner.

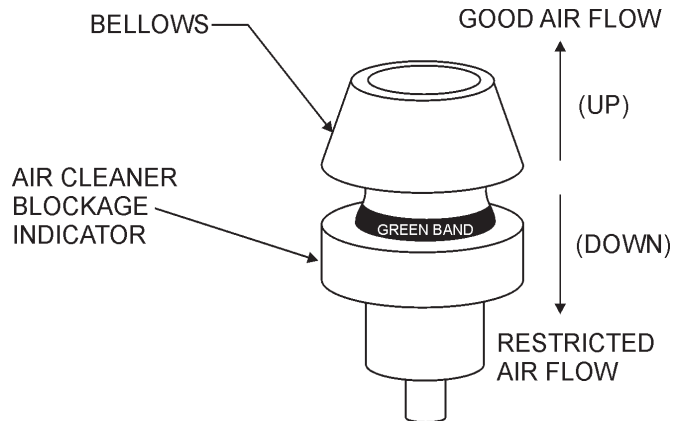

**Figure 10. Air Filter Blockage Indicator**

To clean or replace air filter loosen the wing nut on the air filter housing (Figure 11), remove the cover and take out air filter cartridge. If only cleaning of the air filter is desired blow through the air filter cartridge from the inside, moving a jet of dry compressed air up and down until all dust is removed.

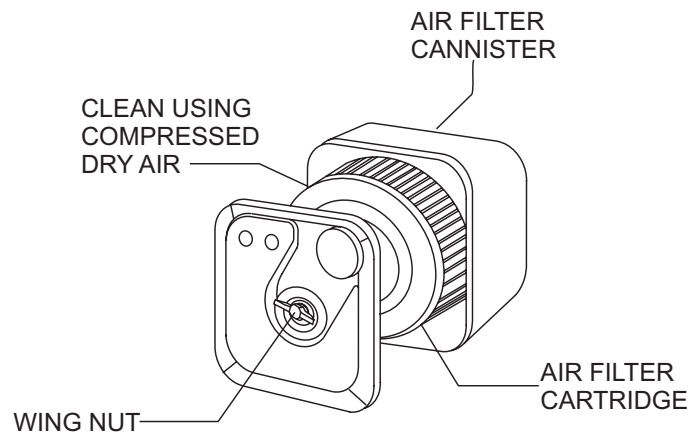

**Figure 11. Air Filter**

## Air Filter Cartridge

If engine is operating in very dusty and dry grass conditions. A clogged air filter will result in high fuel consumption, loss of power and excessive carbon buildup in the combustion chamber. Clean air filter daily. Remember if operating in dusty conditions, check the rubber bellows on the air blockage indicator several times a day.

## CAUTION :



**DO NOT** blow high pressure, high velocity compressed air thru the air filter cartridge. The high velocity air will damage the filter, which will then allow contaminants to pass into the engine.

## Pump Vacuum Test

### CAUTION :



**DO NOT** attempt to start the engine unless the pump has previously been **primed** with water. Severe pump damage will occur if pump has not been primed.

To perform the pump vacuum test do the following:

1. Remove the pump fill cap, and fill the pump with water.
2. Start the engine as outlined in the initial start-up section, and wait for the pump to begin pumping.
3. As shown in Figure 12 (next page), place a water hose inside the discharge opening of the pump, and turn on the water. This flow of water into the discharge opening will **prevent** the pump from running dry.
4. Place the **Pump Vacuum Tester** (P/N 7000030) over the pump inlet opening (Figure 15) with the vacuum gauge facing upwards. It may be necessary to apply a small amount of water around the rubber seal of the vacuum tester to make a good suction fit.
5. Check and make sure that there are no air leaks between the vacuum tester and the inlet port on the pump. If air leaks are present reseal vacuum tester.
6. Run the pump for a few minutes while monitoring the vacuum gauge. If the gauge indicates a reading between -25 and -20 in. Hg. (inches of mercury) then it can be assumed that the pump is working correctly.
7. If the vacuum tester gauge indicates a reading **below** -20 in. Hg, it can then be assumed that the pump is not functioning correctly, and corrective action needs to be taken.
6. To test the **flapper valve**, shut down the engine. The vacuum tester should remain attached to the pump suction inlet port by vacuum. This indicates the pump's flapper valve is seating properly to hold water in the suction hose when the engine is stopped. This prevents backflow and allows for faster priming when the engine is restarted.

#### NOTE

25 in. Hg (inches of mercury) translates into 25 feet of lift at **sea level**.

**CAUTION**  
DO NOT RUN PUMP  
WITHOUT WATER.

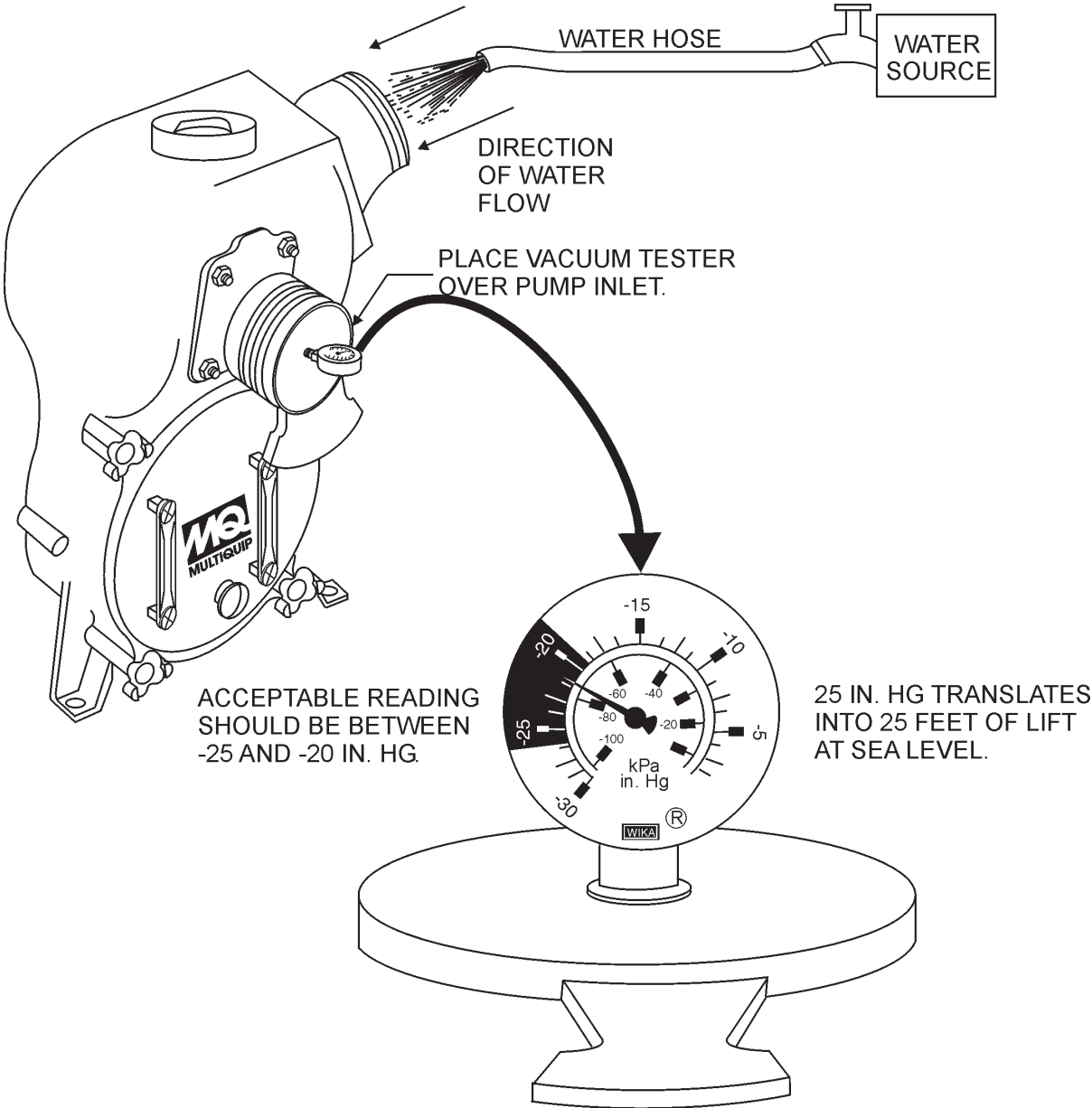

PUMP VACUUM TESTER

Figure 12. Pump Vacuum Tester

## Pump Storage

For storage of the pump for over 30 days, the following is required:

- Drain the fuel tank completely.
- Run the engine until the fuel in the injection system is completely consumed.
- Completely drain used oil from the engine crankcase and fill with fresh clean oil, then follow the procedures described in the engine manual for engine storage.
- Remove the drain plug from the pump and drain out any water from left in the housing.
- Remove the pump cover and clean inside of pump housing. Coat inside of pump housing with a light film of oil to reduce corrosion. A spray can of oil works well for this application.
- Cover suction and discharge ports with duct tape to prevent any foreign matter from falling into pump.
- Cover pump and engine with plastic covering or equivalent and store in a clean, dry place.

# MQ41TDH — TROUBLESHOOTING (PUMP)

Practically all breakdowns can be prevented by proper handling and maintenance inspections, but in the event of a breakdown, use the table shown for pump troubleshooting guide (Table 4) and the engine troubleshooting guide (Table 5). If the problem cannot be remedied, consult our company's business office or service plant.

**TABLE 4 PUMP TROUBLESHOOTING**

SYMPTOM	POSSIBLE PROBLEM	SOLUTION
Pump does not take on water.	Not enough priming water in the housing?	Add water.
	Engine speed too low?	Increase throttle.
	Strainer plugged?	Clean strainer.
	Suction hose damaged?	Replace or repair hose, and clamps
	Air leak at suction port?	Check that fittings are tight and properly sealed.
	Pump is located too high above water line?	Move pump closer to water.
	Debris collecting in pump housing?	Clean pump housing.
	Too much distance between impeller and volute.	Adjust clearance by adding shims or replace impeller. Min. .006" - Max. .020"
	Water leaking out weep hole between pump and engine?	Check condition of mechanical seal and gaskets, between pump end and engine housing.
Pump takes in water, little or no discharge.	Engine speed too low?	Increase throttle speed.
	Suction strainer partially plugged?	Clean strainer.
	Impeller/Volute worn?	Adjust clearance by adding shims or replace impeller/volute
Suction hose leaks at inlet.	Fittings/clamps are not sealed properly?	Tighten, replace or add clamp. (Keep extra seals on pump)
	Hose diameter is too large?	Use smaller diameter hose or replace hose.
Discharge does not stay on coupling.	Pressure too high?	Check pressure, add additional clamp.
	Hose kinked or end blocked?	Check hose.
Impeller does not turn: pump is hard to start.	Impeller jammed or blocked?	Open pump cover and clean dirt and debris from inside housing.
	Impeller and volute binding?	Adjust clearance by removing shim from behind impeller.
	Defective engine?	See Hatz Diesel Engine Owner's Manual.

# MQ41TDH — TROUBLESHOOTING (ENGINE)

**TABLE 5 ENGINE TROUBLESHOOTING**

SYMPTON	POSSIBLE PROBLEM	SOLUTION
Engine will not start or start is delayed, although engine can be turned over.	Speed control lever is in "STOP" position?	Set speed control lever to "START" position.
	STOP solenoid is in the "STOP" position?	Set stop solenoid to the "START" position. Adjust and lubricate if necessary.
	No Fuel reaching injection pump?	Add fuel. Check entire fuel system.
	Defective fuel pump?	Replace fuel pump.
	Fuel filter clogged?	Replace fuel filter and clean tank.
	Faulty fuel supply line?	Replace or repair fuel line.
	Compression too low?	Check piston, cylinder and valves. Adjust or repair per engine repair manual.
	Fuel injector not working correctly?	Repair or replace injector in accordance with engine repair manual.
	Oil pressure too low?	Check engine oil pressure.
	Low starting temperature limit exceeded	Comply with cold starting instructions and proper oil viscosity.
Defective battery?	Charge or replace battery.	
At low temperatures engine will not start.	Fuel separates has inadequate resistance to low temperatures?	Check whether clear (not turbid) fuel emerges from the fuel line (detach from injection pump). If the fuel is turbid or separated, warm up the engine or drain the complete fuel supply system. Refuel with winter grade diesel fuel.
	Engine oil too thick?	Refill engine crankcase with correct type of oil for winter environment.
	Defective battery?	Replace battery.
Engine fires but stops soon as starter is switched off.	Throttle lever in STOP position?	Reposition throttle lever to RUN position.
	Fuel filter blocked?	Replace fuel filter.
	Fuel supply blocked?	Check the entire fuel system.
	Electrical problem at fuel solenoid?	Repair using #7 wire.
Engine stops by itself during normal operation.	Fuel tank empty?	Add fuel.
	Fuel filter blocked?	Replace fuel filter.
	Defective fuel pump?	Replace fuel pump.
	Mechanical oil pressure shutdown sensor stops the engine due to low oil?	Add oil. Replace low oil shutdown sensor if necessary.

# MQ41TDH — TROUBLESHOOTING (ENGINE)

**TABLE 5 ENGINE TROUBLESHOOTING (CONTINUED)**

SYMPTON	POSSIBLE PROBLEM	SOLUTION
Low engine power, output and speed.	Fuel tank empty?	Replace fuel filter.
	Fuel filter clogged?	Replace fuel filter.
	Fuel tank venting is inadequate?	Ensure that tank is adequately vented.
	Leaks at pipe unions?	Check threaded pipe unions tape and tighten unions as required.
	Speed control lever does not remain in selected position?	See engine manual for corrective action.
	Engine oil level too full?	Correct engine oil level?
Low engine power output and low speed, black exhaust smoke.	Air filter blocked?	Clean or replace air filter.
	Incorrect valve clearances?	Adjust valves per engine specification.
	Malfunction at injector?	See engine manual.
Air-cooled diesel engine runs very "HOT". Cylinder head overheat, telltale lamp comes on (option)	Too much oil in engine crankcase?	Drain off engine oil down to uppermark on dipstick.
	Entire cooling air system contaminated blocked?	Clean cooling air system, remove shrouds and cooling fin areas.
	Inadequate sealing at air guide plates or capsule elements?	Check that air guide plates and enclosure elements are all present and make a tight seal.



# MQ41TDH — EXPLANATION OF CODE IN REMARKS COLUMN

The following section explains the different symbols and remarks used in the Parts section of this manual. Use the help numbers found on the back page of the manual if there are any questions.

The contents and part numbers listed in the parts section are subject to change **without notice**. Multiquip does not guarantee the availability of the parts listed.

Sample Parts List:

<u>NO.</u>	<u>PART NO.</u>	<u>PART NAME</u>	<u>QTY.</u>	<u>REMARKS</u>
1	12345	BOLT .....	1 ....	INCLUDES ITEMS W/*
2*		WASHER, 1/4 IN. ....		NOT SOLD SEPARATELY
2*	12347	WASHER, 3/8 IN. ....	1 ....	MQ-45T ONLY
3	12348	HOSE .....	A/R ..	MAKE LOCALLY
4	12349	BEARING .....	1 ....	S/N 2345B AND ABOVE

## NO. Column

**Unique Symbols** - All items with same unique symbol (\*, #, +, %, or >) in the number column belong to the same assembly or kit, which is indicated by a note in the “Remarks” column.

**Duplicate Item Numbers** - Duplicate numbers indicate multiple part numbers are in effect for the same general item, such as different size saw blade guards in use or a part that has been updated on newer versions of the same machine.

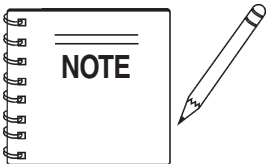

When ordering a part that has more than one item number listed, check the remarks column for help in determining the proper part to order.

## PART NO. Column

**Numbers Used** - Part numbers can be indicated by a number, a blank entry, or TBD.

TBD (To Be Determined) is generally used to show a part that has not been assigned a formal part number at time of publication.

A blank entry generally indicates that the item is not sold separately or is not sold by Multiquip. Other entries will be clarified in the “Remarks” Column.

## QTY. Column

**Numbers Used** - Item quantity can be indicated by a number, a blank entry, or A/R.

A/R (As Required) is generally used for hoses or other parts that are sold in bulk and cut to length.

A blank entry generally indicates that the item is not sold separately. Other entries will be clarified in the “Remarks” Column.

## REMARKS Column

Some of the most common notes found in the “Remarks” Column are listed below. Other additional notes needed to describe the item can also be shown.

**Assembly/Kit** - All items on the parts list with the same unique symbol will be included when this item is purchased.

Indicated by:

“INCLUDES ITEMS W/(unique symbol)”

**Serial Number Break** - Used to list an effective serial number range where a particular part is used.

Indicated by:

“S/N XXXXX AND BELOW”

“S/N XXXX AND ABOVE”

“S/N XXXX TO S/N XXX”

**Specific Model Number Use** - Indicates that the part is used only with the specific model number or model number variant listed. It can also be used to show a part is NOT used on a specific model or model number variant.

Indicated by:

“XXXXX ONLY”

“NOT USED ON XXXX”

**“Make/Obtain Locally”** - Indicates that the part can be purchased at any hardware shop or made out of available items. Examples include battery cables, shims, and certain washers and nuts.

**“Not Sold Separately”** - Indicates that an item cannot be purchased as a separate item and is either part of an assembly/kit that can be purchased, or is not available for sale through Multiquip.

# MQ41TDH — SUGGESTED SPARE PARTS

## MQ41TDH 1 TO 5 UNITS WITH HATZ 1D81Z ENGINE

### *1 to 5 Units*

Qty.	P/N	Description
1	0482200280	O RING (MECHNAICAL SEAL SLEEVE)
2	0806124035	MECHANICAL SEAL
1	0811303554	MECHANICAL SEAL SLEEVE
3	0852824230	ADJUST LINER
3	0852854230	ADJUST LINER
3	0480350300	O-RING
1	4412000030	IMPELLER
2	0489312820	O RING(CASING, VOLUTE)
1	0489312960	O RING (DRAIN COVER)
1	4412000130	VOLUTE CASING
1	1401350350	CHECK VALVE
4	0631211100	DRAIN CAP
3	0480350300	O RING, DRAIN CAP
4	2601000220	DRAIN COVER KNOB
1	0742064100	STEEL STRAINER
5	01493000	AIR FILTER
5	01480000	OIL FILTER
5	50478800	FUEL FILTER
5	50345300	KEY, IGNITION SWITCH
1	40021300	OIL PRESSURE SWITCH
1	50268600	TEMPERATURE SWITCH

#### NOTE

Part numbers on this Suggested Spare Parts List may supercede/replace the P/N shown in the text pages of this book.

# MQ41TDH — NAME PLATE AND DECALS

## NAMEPLATE AND DECALS

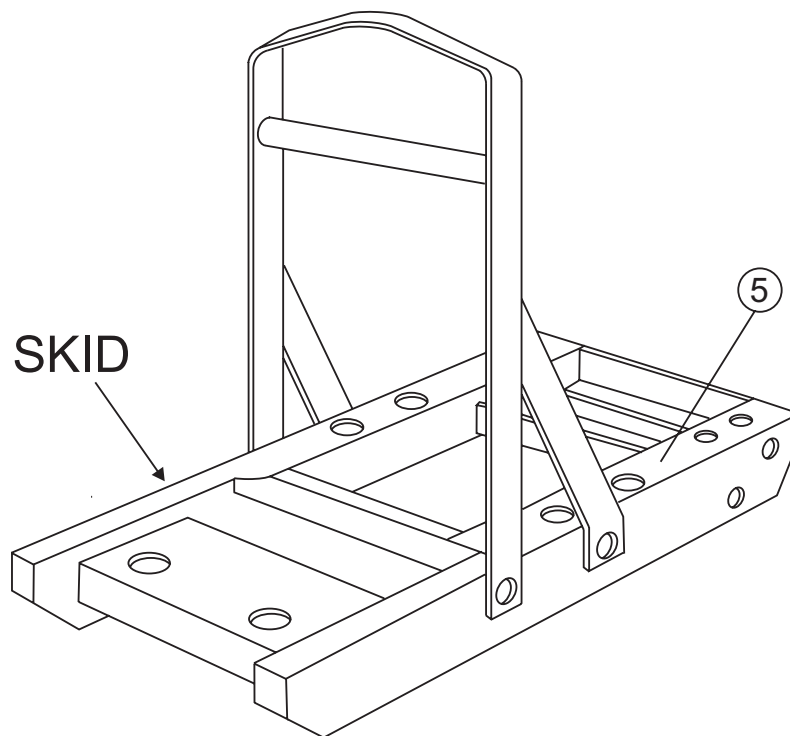
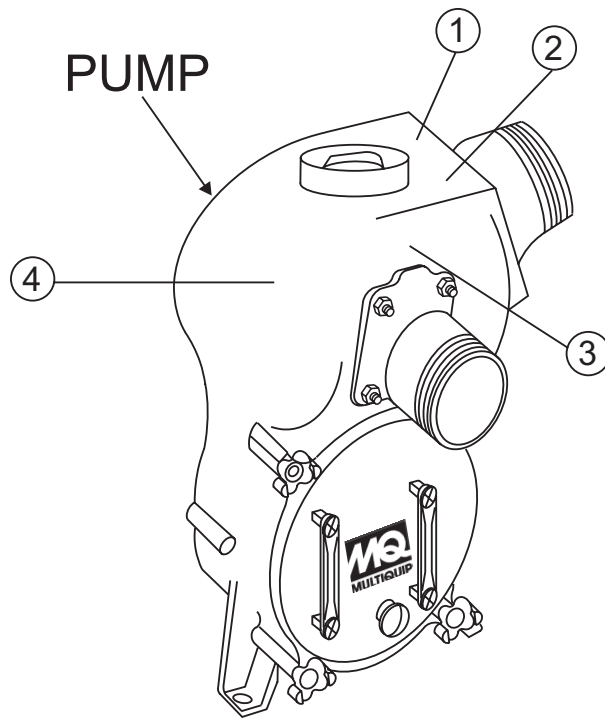

# MQ41TDH — NAME PLATE AND DECALS

## NAMEPLATE AND DECALS

<u>NO</u>	<u>PART NO</u>	<u>PART NAME</u>	<u>QTY.</u>	<u>REMARKS</u>
1*	DCS02	DECAL: CAUTION	1	
2*	7005000	DECAL: DO NOT RUN DRY	1	
3*	5349	DECAL: MULTIQUIP	1	
4		PLATE, SERIAL NO .....	1 .....	CONTACT MQ SERVICE DEPT. W/MODEL & S/N
5*	920203290	DECAL: CAUTION .....	1 .....	REPLACES 920202510
6	DCLMQ41THD	KIT, DECAL .....	1 .....	INCLUDES ITEMS W/★

SEE DECAL ILLUSTRATIONS ON PAGE 10

# MQ41TDH — PUMP ASSY.

PUMP ASSY.

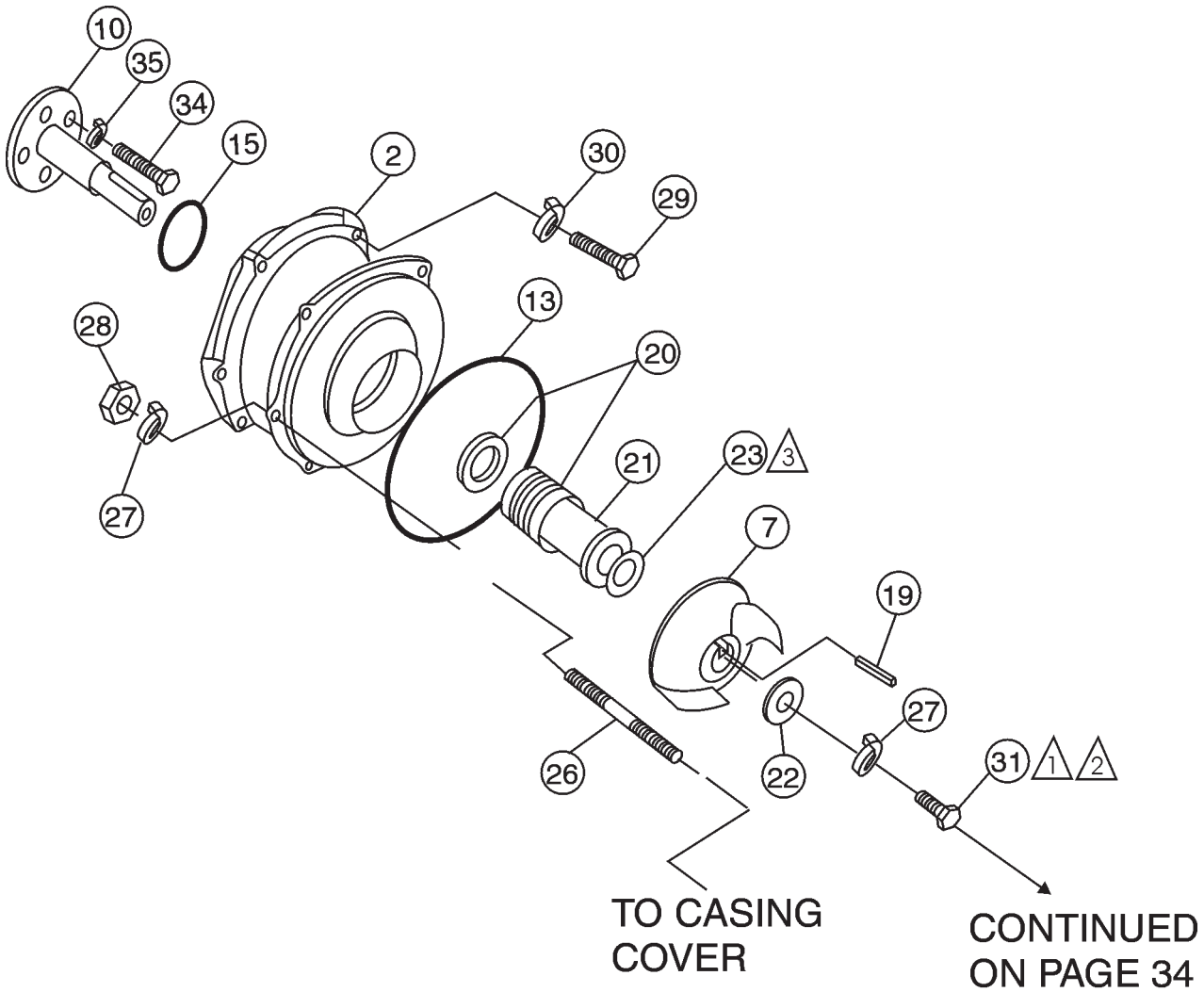

## NOTES:

1 APPLY LOCTITE P/N 271

2 TORQUE TO 34 FT. LBS

3 ITEM 23, (SHIMS) ARE USED TO PROVIDE .006 - .020 INCHES OF CLEARANCE BETWEEN IMPELLER AND VOLUTE. USE AS REQUIRED.

PUMP ASSY.

<u>NO</u>	<u>PART NO</u>	<u>PART NAME</u>	<u>QTY.</u>	<u>REMARKS</u>
2	4419000020	CASING COVER .....	1	REPLACES 4412000020
7	4412000030	IMPELLER .....	1	REPLACES 4110030
10	SHAFT 1D81Z			
13	0489312820	"O-RING" (CASING VOLUTE) .....	1	REPLACES 4110134
15	0482200280	"O-RING" (MECHANICAL SEAL SLEEVE) .....	1	REPLACES 4115204
19	0521070740	KEY .....	1	REPLACES 6100103
20	0806124035	MECHANICAL SEAL (CERAMIC-CARBON) .....	1	REPLACES 0801124035 & 0801224035
21	0811303554	MECHANICAL SEAL SLEEVE .....	1	REPLACES 4115210
22	4412201240	IMPELLER WASHER .....	1	REPLACES 6000033
23	0852824230	SHIM 42X30 MM X .02 MM .....	1	REPLACES 4118110
23	0852834230	SHIM 42X30 MM X .03 MM .....	1	REPLACES 4118110
23	0852854230	SHIM 42X30 MM X .05 MM .....	1	REPLACES 4118110
26	0151151230	STUD BOLT M12 X 45 X 15 X 20 .....	18	REPLACES 4004512
27	0451250120	LOCK WASHER .....	15	REPLACES 4001202
28	0205450120	NUT, M12 .....	14	REPLACES 1501201
29	0131151060	SCREW CASING COVER	8	
30	0451250100	LOCK WASHER	7	
31	0105051225	BOLT (IMPELLER)	1	
34	014208025	ALLENHEAD BOLT, 8 X 25 - 1.25MM	4	
35	030208200	LOCK WASHER, 8MM	4	

# MQ41TDH — PUMP ASSY. (CONTINUED)

PUMP ASSY. (CONTINUED)

CONTINUED  
FROM PAGE 32

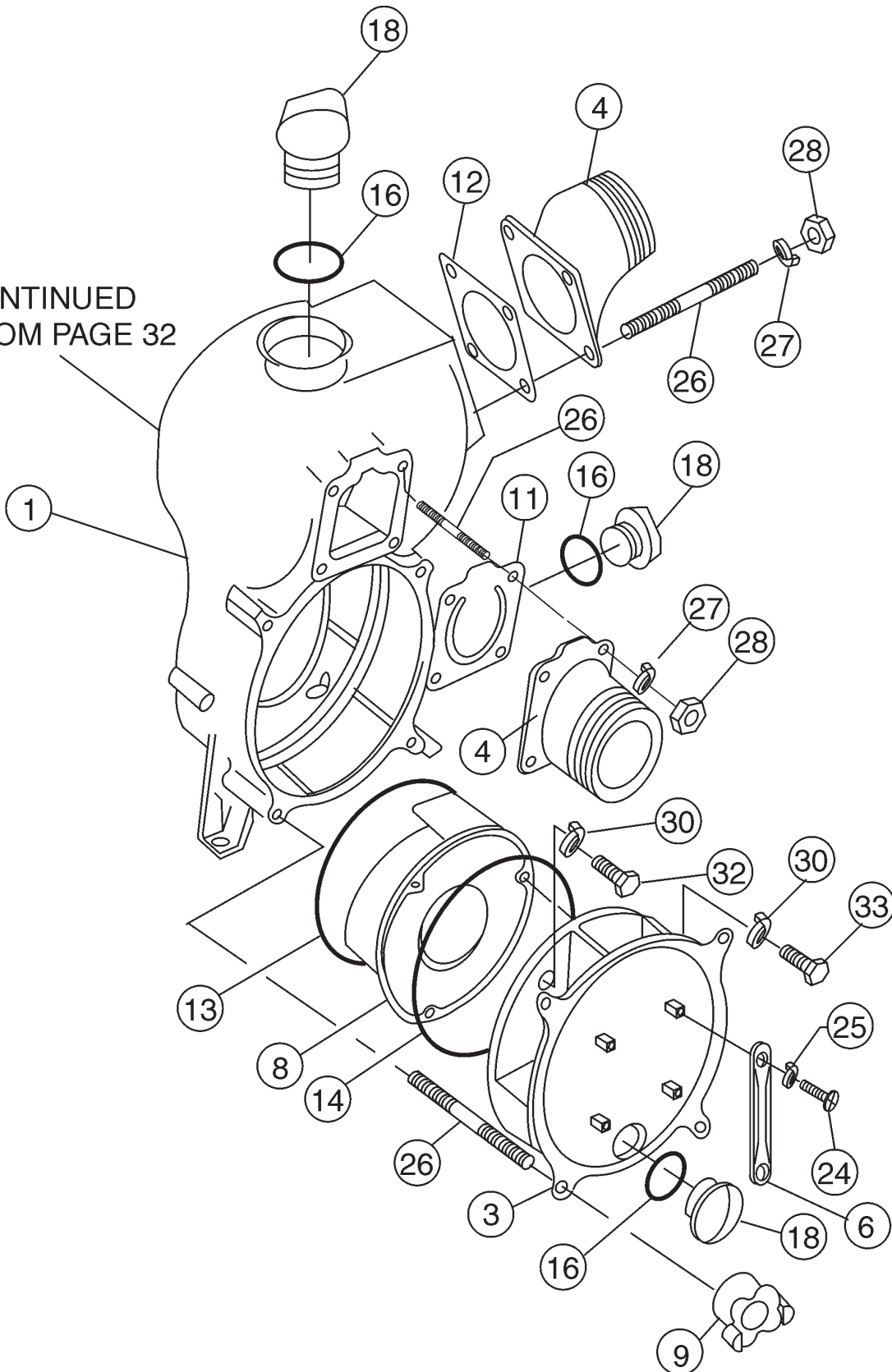

## MQ41TDH — PUMP ASSY. (CONTINUED)

### PUMP ASSY. (CONTINUED)

<u>NO</u>	<u>PART NO</u>	<u>PART NAME</u>	<u>QTY.</u>	<u>REMARKS</u>
1	4412000010	CASING .....	1	REPLACES 4110010
3	4412000170	DRAIN COVER .....	1	REPLACES 4110170
4	1414000090	SUCTION/DISCHARGE PORT .....	2	REPLACES 4000090
6	1247100250	DRAIN COVER HANDLE .....	2	REPLACES 2010190
8	4412000130	VOLUTE CASING .....	1	REPLACES 4110130
9	2601000220	DRAIN COVER KNOB .....	4	REPLACES 4110171
11	1401350350	CHECK VALVE	1	
12	1401330360	DISCHARGE PORT GASKET .....	1	REPLACES 4000094
13	0489312820	O-RING (CASING, VOLUTE) .....	1	REPLACES 4110134
14	0489312960	O-RING (DRAIN COVER) .....	1	REPLACES 4110174
16	0480350300	O-RING, DRAIN CAP .....	3	REPLACES 1506064
17	0631211100	FILL/DRAIN CAP .....	1	REPLACES 1506060
18	0631211100	DRAIN CAP .....	2	REPLACES 1506060
24	0141050825	SCREW (DRAIN COVER HANDLE) .....	4	REPLACES 2018025
25	0451250080	LOCK WASHER .....	4	REPLACES 150802
26	0151151230	STUD BOLT, M12 X 45 X 15 X 20 .....	18	REPLACES 4004512
27	0451250120	LOCK WASHER, M12 .....	15	REPLACES 4001202
28	0205450120	NUT, M12 .....	14	REPLACES 1501201
29	0105051065	BOLT (CASING COVER)	6	
30	0451250100	LOCK WASHER .....	12	REPLACE S2001002
32	0105091025	BOLT (VOLUTE CASING) .....	2	REPLACES 4111025
33	0105091020	BOLT (VOLUTE CASING)	1	

# MQ41TDH — SKID ASSY.

SKID ASSY.

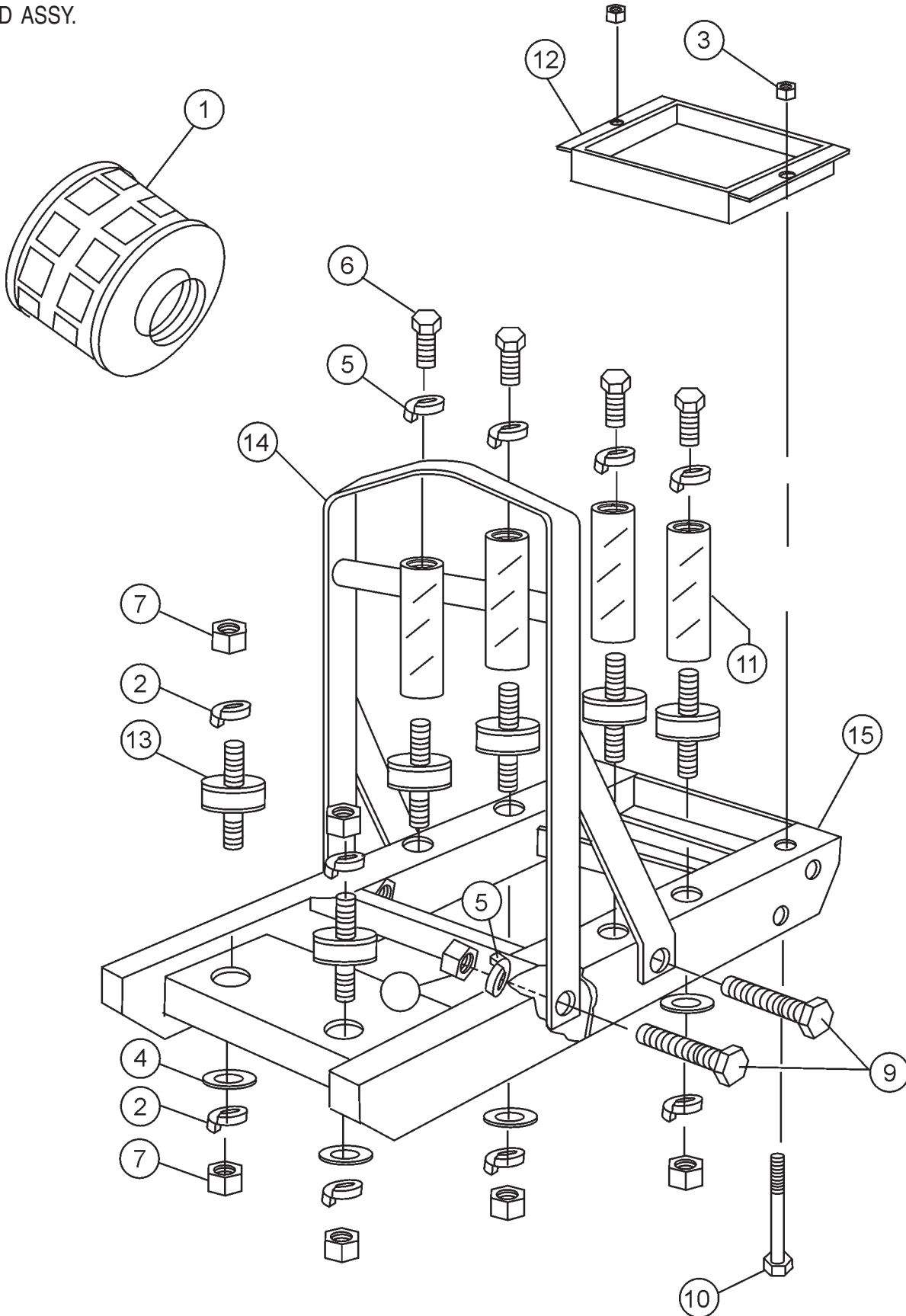

SKID ASSY.

<u>NO</u>	<u>PART NO</u>	<u>PART NAME</u>	<u>QTY.</u>	<u>REMARKS</u>
1	0742064100	STRAINER STEEL	1	
2	030210250	WASHER SPRING 10MM	7	
3	3019091	NUT	2	
4	3019092	WASHER 3/8	6	
5	6109180	WASHER SPRING	8	
6	012212025	BOLT 12x25T	4	
7	020310080	NUT M10 HEX NUT Zn PLATED	8	
8	6109160	NUT	4	
9	6109210	BOLT	4	
10	6109108	BOLT BATTERY HOLD DOWN	2	
11	4419200580	SPACER	4	
12	6109100	HOLD DOWN BATTERY	1	
13	0723302546	SHOCK MOUNT .....	6	..... REPLACES 030216400
14	6119102	LIFTING BAIL	1	
15	6119101A	PUMP & ENGINE BASE	1	

# MQ41TDH — TRAILER-10 ASSY.

TRAILER-10 ASSY.

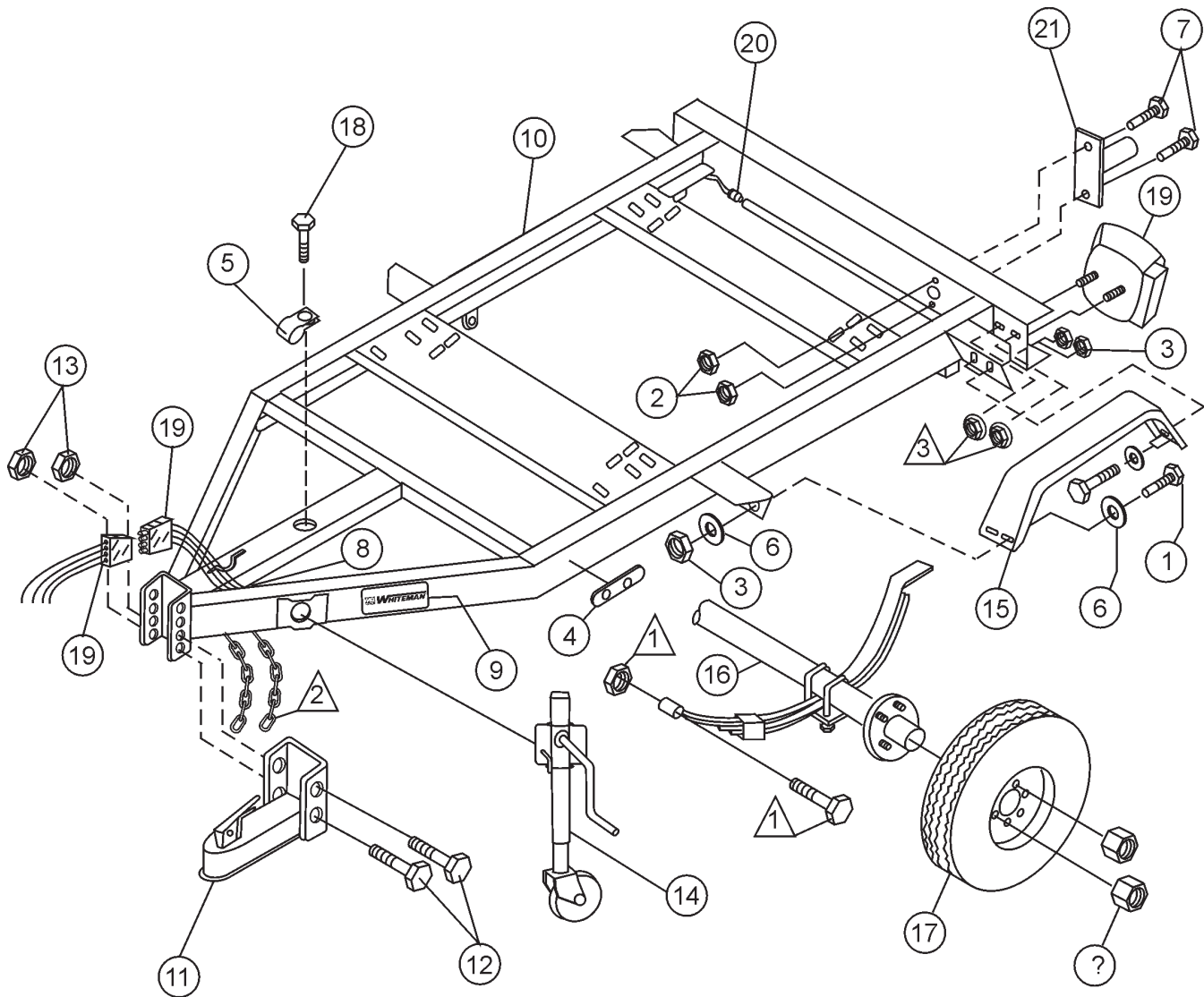

## NOTES:

- ① INCLUDED WITH SPRING MOUNT KIT.
- ② SAFETY CHAIN IS WELDED TO FRAME.
- ③ INCLUDED WITH LIGHT KIT P/N 9510.
- ④ USE AS REQUIRED BY LOCAL REGULATIONS.

# MQ41TDH — TRAILER -10 ASSY.

## TRAILER-10 ASSY.

<u>NO</u>	<u>PART NO</u>	<u>PART NAME</u>	<u>QTY.</u>	<u>REMARKS</u>
1	0205	SCREW, HHC 3/8-16 x 1	8	
2	10019	NUT, NYLOC 10-32	2	
3	10133	NUT, NYLOC 3/8-16	8	
4	19103	REFLECTOR, AMBER STICK-ON	2	
5	2548	CLAMP, CABLE	1	
6	4001	WASHER, FLAT, 3/8 PLTD STD.	16	
7	5065	SCREW, RHM 10-32 x 1/2	2	
8	60101	TIE, SELF-LOCKING	6	
9	9315	DECAL, TRLR-10	1	
10	9500	FRAME, TRLR W/A	1	
11	19102	HITCH W/A, BALL	1	
12	9502	SCREW, HHC 5/8-11 x 4-1/2 GR8	2	
13	9503	NUT, NYLOC 5/8-11	2	
14	9504	JACK, SWIVEL W/WHEEL (COMPLETE)	1	
15	9505	FENDER, 8x30x13, (TRLR-10, -50)	2	
16	9506	AXLE & SPRING ASSY.	1	
17	9508	TIRE/WHL P155 80D13 BLACK RIM	2	
18	9509	SCREW, TEK 12 x 3/4 SELF TAP	1	
19	9510	KIT, LIGHT - TRAILER	1	
20	9512	PLUG, WIRING	6	
21	9514	LIGHT ASSY., LICENSE PLATE	1	
22	1U1304	WHEEL LUG NUT	16	

# MQ41TDH — TRAILER -1 KIT ASSY.

TRAILER -1 ASSY.

## CAUTION :



**NEVER** use the Trailer-1 for "HIGHWAY" towing purposes. This trailer is intended for *jobsite* towing **ONLY!**

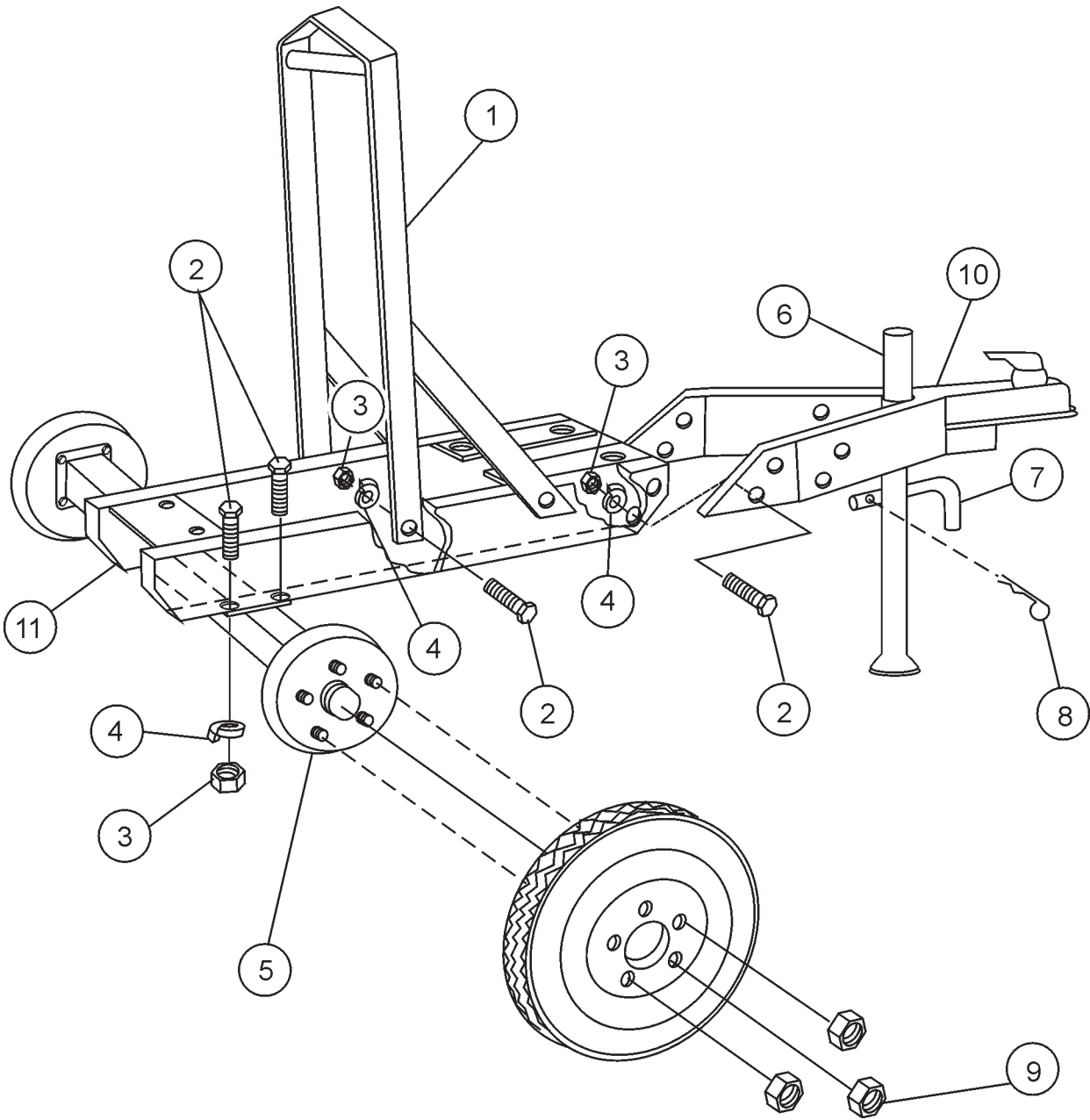

# MQ41TDH — TRAILER -1 KIT ASSY.

## TRAILER -1 ASSY.

<u>NO</u>	<u>PART NO</u>	<u>PART NAME</u>	<u>QTY.</u>	<u>REMARKS</u>
1	6119102	LIFTING BAIL	1	
2	6109210	CAP SCREW	12	
3	6109160	NUT, HEX	12	
4	6109180	WASHER, SPRING	12	
5	6109117	AXLE AND HUB ASSY.	1	
6	6109104	PIPE STAND	1	
7	6109146	LOCATING PIN	1	
8	0183	COTTER PIN	1	
9	1U1304	WHEEL LUG NUTS	16	
10	6109105	TOW BAR COUPLER	1	
11	6119101A	PUMP & ENGINE BASE	1	

WHL-2 KIT ASSY.

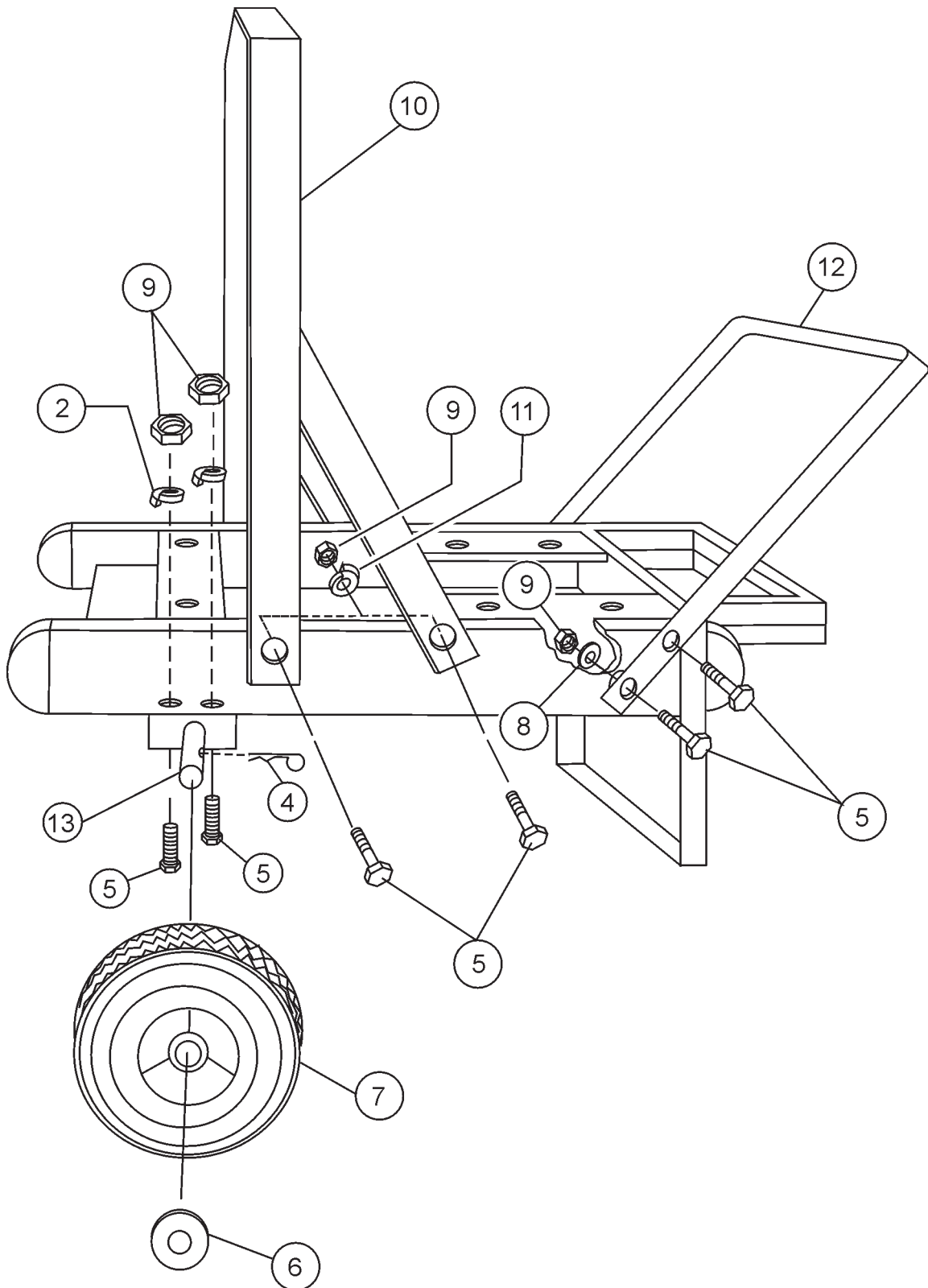

# MQ41TDH — WHL-2 KIT ASSY.

## WHL-2 KIT ASSY.

<u>NO</u>	<u>PART NO</u>	<u>PART NAME</u>	<u>QTY.</u>	<u>REMARKS</u>
2	6109170	WASHER, SPRING	4	
4	2010176	SPLIT PIN	2	
5	6109210	CAP SCREW	12	
6	8151	WASHER, FLAT, 3/4 IN.	2	
7	4119149	TIRE/WHEEL	2	
8	4119208	WASHER, FLAT	4	
9	6109160	NUT	12	
10	6119102	LIFTING BAIL	1	
11	6109180	WASHER, SPRING	4	
12	4119102	HANDLE	1	
13	4119103	AXLE	1	

# MQ41TDH — TNKZZ FUEL TANK ASSY. (OPTIONAL)

TNKZZ FUEL TANK ASSY. (OPTIONAL)

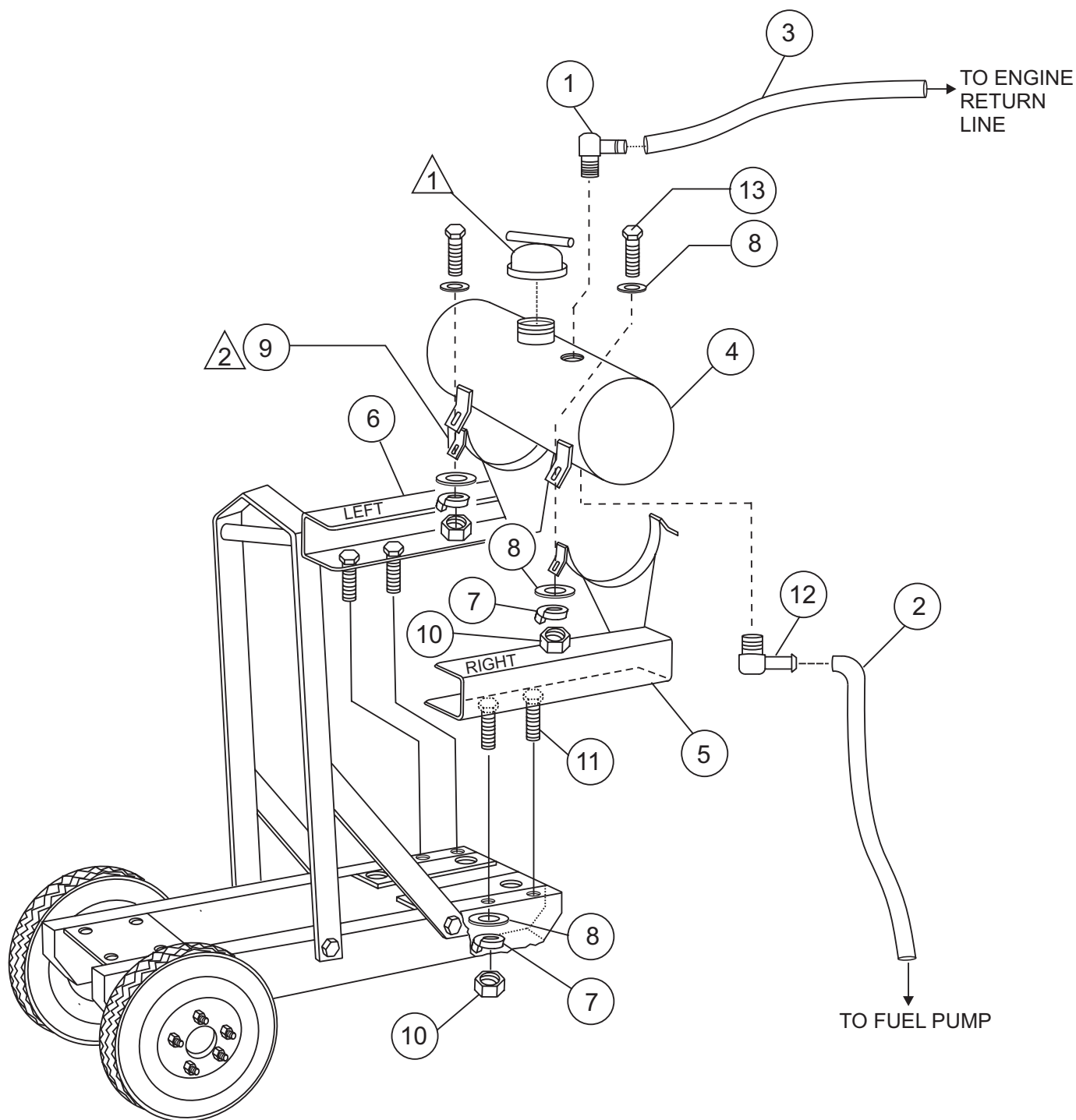

## NOTES:

① CAP IS INCLUDED WITH TANK.

② IF A GAP EXISTS BETWEEN THE TANK BRACKET AND THE THE TANK SHIM USING P/N 6109170.

## MQ41TDH — TNKZZ FUEL TANK ASSY. (OPTIONAL)

### TNKZZ FUEL TANK ASSY. (OPTIONAL)

<u>NO</u>	<u>PART NO</u>	<u>PART NAME</u>	<u>QTY.</u>	<u>REMARKS</u>
1	34426	ELBOW BRASS 3/16 X 1/8NPT	1	
2	6635	HOSE, FUEL 1/4 INCH DIAMETER	60 IN.	
3	6636	HOSE FUEL, 5/16 INCH	16 IN.	
4	TNK9120	TANK	1	
5	TNK9123	TANK BRACKET (LEFT)	1	
6	TNK9124	TANK BRACKET (RIGHT)	1	
7	030210250	WASHER, SPRING	8	
8	3019092	WASHER 3/8	12	
9	6109170	WASHER	12	
10	020310080	NUT, HEX M10 ZN PLATED	8	
11	2101030	BOLT, HEX 10 X 30	4	
12	84454	ELBOW BRASS 1/4 MALE NPT X 5/16	1	
13	2001040	BOLT	4	

# HATZ 1D81Z ENGINE — CRANKCASE ASSY.

CRANKCASE ASSY.

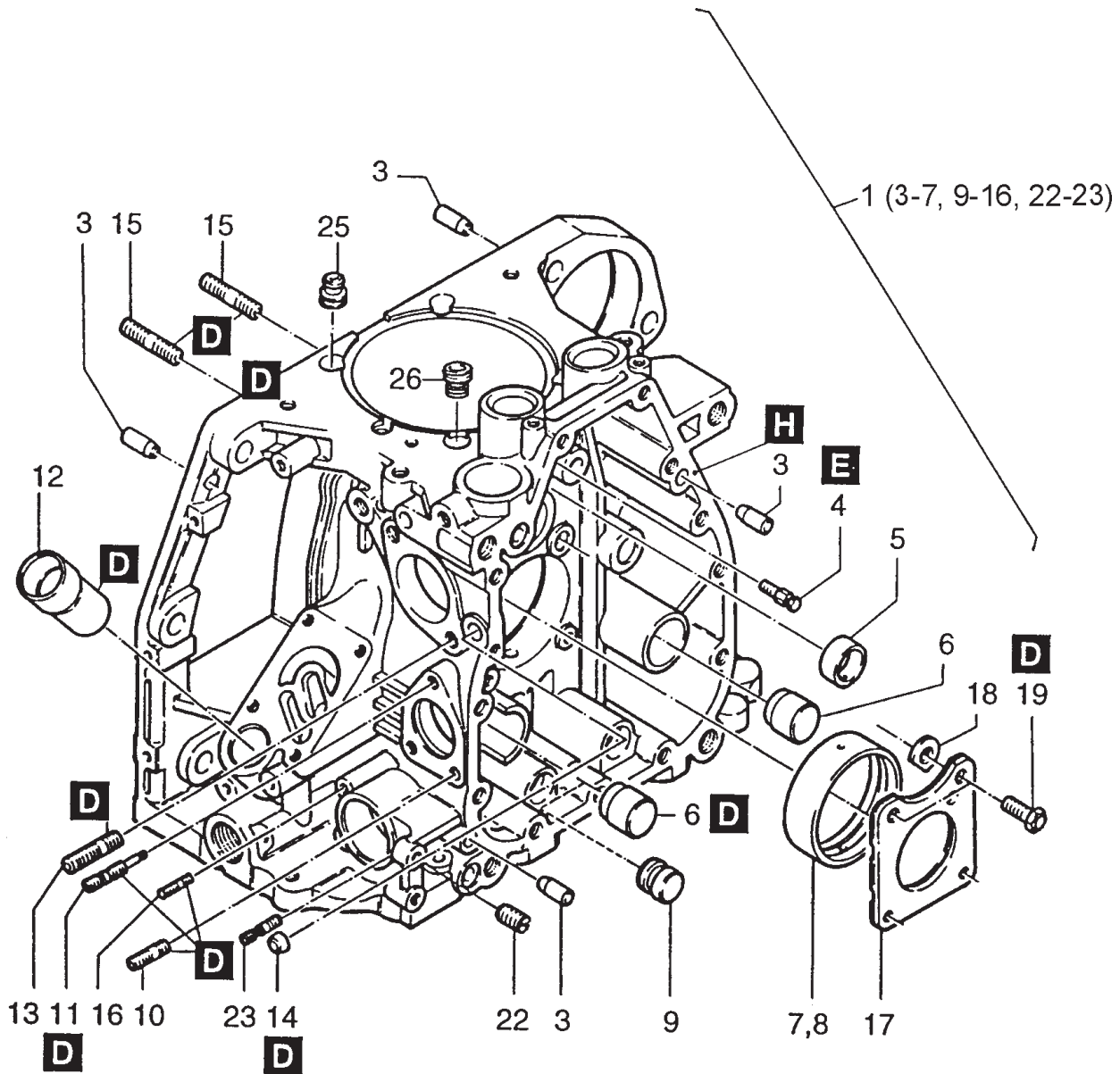

LETTERS IN BOLD INDICATE TYPE OF BONDING ADHESIVE TO BE USED.

D= LOCTITE 221 H= SILICON E= LOCTITE 648

# HATZ 1D81Z ENGINE — CRANKCASE ASSY.

## CRANKCASE ASSY.

<u>NO.</u>	<u>PART NO.</u>	<u>PART NAME</u>	<u>QTY.</u>	<u>REMARKS</u>
1	01249051	CRANKCASE .....	1	INCLUDES ITEMS W/*
3*	50249101	CYL. PIN 6/20	4	
4*	03793900	NOZZLE	1	
5*	03793800	BEARING BUSH	1	
6*	03794000	PLUG	1..2	
7*	03793700	MAIN BEARING	1	
8	04033700	MAIN BEARING -O.5	1	
9*	04000800	PLUG	1	
10*	50144300	STUD M 6X16	2	
11*	03794510	STUD	1	
12*	03794800	INTERMEDIATE PIECE	1	
13*	50098300	STUD 8 X 20	2	
14*	50325500	COVER 10	1	
15*	50037800	STUD M 8 X 22	8	
16*	50328200	STUD M 16 X 22	2	
17	04011650	THRUST PLATE	1	
18	04069500	SHIM 1.05	0..4	
19	04062010	HEX SCREW M 9 X 28	4	
22*	50357700	GRUB SCREW M 8 X 10	1	
23*	04087400	STUD M 6 X 22	1	
25	04084500	SEALING RING	2	
26	04084500	SEALING RING	2	

# HATZ 1D81Z ENGINE — CRANKCASE ASSY. (EXTERNAL PARTS)

CRANKCASE ASSY.(EXTERNAL PARTS)

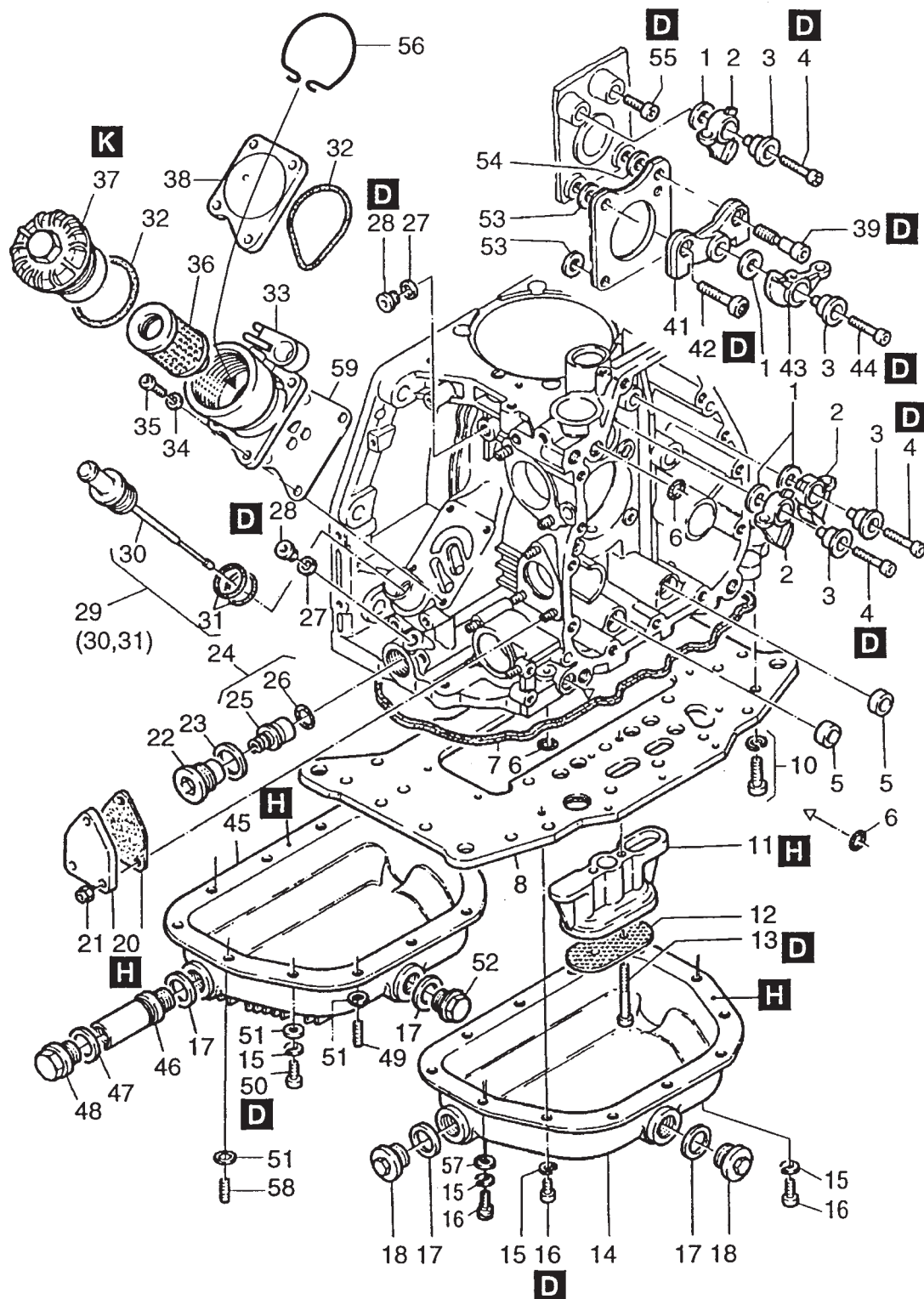

LETTERS IN BOLD INDICATE TYPE OF BONDING ADHESIVE TO BE USED.

D= LOCTITE 221 H= SILICON E= LOCTITE 648

# HATZ 1D81Z ENGINE — CRANKCASE ASSY. (EXTERNAL PARTS)

## CRANKCASE ASSY.(EXTERNAL PARTS)

<u>NO.</u>	<u>PART NO.</u>	<u>PART NAME</u>	<u>QTY.</u>	<u>REMARKS</u>
1	03794100	WASHER	2	
2	03794300	CAM FOLLOWER	2	
3	93794201	CAM FOLLOW SPINDLE	2	
4	50051000	ALLEN SCREW M 6 X 30	2	
5	03795800	O-RING 12 X 18, 3 X 7.3	2	
6	50329000	O-RING 9.5 X 2.5	3	
7	03795100	O-RING 265 X 269, 4 X 3.6	1	
8	01248810	PLATE	1	
10	50417600	ALL. SCREW. M 8 X 25 Z4	22	
11	03794900	HOUSING	1	
12	03795000	SUCTION SIEVE	1	
13	50327100	ALLEN SCREW M 6 X 50	2	
14	01241700	OIL SUMP	1	
15	50170900	LOCK WASHER 6	12	
16	50329100	ALLEN SCREW M 6 X 10	12	
17	50001600	JOINT A22X27	2	
18	50373100	DRAIN PLUG M 22 X 1.5	0..2	
18	50140400	DRAIN PLUG	0..2	
20	03794700	COVER	1	
21	50328300	HEXAGON NUT M6	3	
22	01321200	CLOS. SCREW + SIEVE	1	
23	50286400	JOINT A 24 X 29	1	
24	01321100	OIL RELIEF VALVE ASSY. ....	1	INCLUDES ITEMS W/#
25#		OIL RELIEF VALVE .....	1	CANNOT BE PURCHASED SEPARATELY
26#	50412900	O-RING 18 X 2	1	
27	50062400	JOINT A10 X 13.5	2	
28	50062300	CLOSING SCREW M10 X 1	2	
29	01241500	DIPSTICK ASSY .....	1	INCLUDES ITEMS W/
30*		DIPSTICK .....	1	CANNOT BE PURCHASED SEPARATELY
31*	50359700	O-RING 20.29 X 2.62	2	
32*	50329200	O-RING 50X55X3	2	
33	05068800	LUB. OIL FILT. HOUS.	1	
34	50081200	LOCK WASHER A6	4	
35	50170600	ALLEN SCREW M 6 X 20	4	
36	01480000	SUPRA OIL FILTER	1	
37	01248900	COVER	1	
38	04033401	COVER	1	
39	04053210	SET SCREW M9	1	
41	04024220	CAM FOLLOWER BRACK.	1	
42	04062110	BOLT	1	
43	04024301	CAM FOLLOWER T/U	1	
44	50170800	ALLEN SCREW M 6 X 25	1	
45	04045800	OIL SUMP	1	
46	04046300	DRAIN EXTENSION	1	
47	50001400	JOINT A 18 X 22	1	
48	50044200	CLOS. SCREW M 18 X 1.5	1	
49	50434300	STUD M 8 X 18	2	
50	50050700	ALLEN SCREW M 6 X 16	8	
52	50140400	DRAIN PLUG	1	
53	04069500	SHIM 1.05	0..3	
53	04069600	SHIM 1.2	0..3	
54	04069800	SHIM 1.05	0..1	
54	04069900	SHIM 1.20	0..1	
55	04065400	CYLINDER HEAD BOLT	1	
56	04084000	LIFTING SPRING	1	
58	50139200	STUD M 6 X 16	2	
59	05068900	GASKET	1	



# HATZ 1D81Z ENGINE — CRANKSHAFT ASSY.

## CRANKSHAFT ASSY.

<u>NO.</u>	<u>PART NO.</u>	<u>PART NAME</u>	<u>QTY.</u>	<u>REMARKS</u>
1	01269810	CRANKSHAFT ASSY. ....	1	INCLUDES ITEMS W/*
2*		CRANKSHAFT .....	1	CANNOT BE PURCHASED SEPARATELY
3*	50087200	COVER 28	1	
4	03796000	COUNTER WEIGHT	1	
5	50055000	ALLEN SCREW M 10 X 50	2	
6*	50362600	FITTING KEY A 6 X 4 X 32	1	
7	03796120	GEARWHEEL F. CRANKS	1	
8	04000600	BUFFER RING	1	
9	50224900	O-RING 123 X 2.5	1	
10	01292100	BEARING FLANGE ASSY. ....	1	INCLUDES ITEMS W/#
11#		BEARING FLANGE .....	1	CANNOT BE PURCHASED SEPARATELY
12#	04006800	MAIN BEARING		
13	04036100	MAIN BEARING -0.5	1	
14#	50362700	OIL SEAL 62 X 90 X 10	1	
15	50413600	WASHER	8	
16	50364300	HEXAGON NUT M8	8	
17	04023110	STUBSHAFT SAE W/KEY	1	
18	01485500	STUBSHAFT SAE TAPER	1	
19	04022910	STUBSHAFT ITALIA	1	
20	05033200	STUBSHAFT ITALIA 23	1	
21	03962700	FITTING KEY A6.35 X 63	1	
22	50017800	WOODRUFF KEY 4 X 6.5	1	
23	50414400	WEAR SLEEVE 62 X 12.7	0..1	
24	01512001	KIT, CRANKSHAFT REPLACEMENT60-81	1	

# HATZ 1D81Z ENGINE — CAMSHAFT ASSY.

CAMSHAFT ASSY.

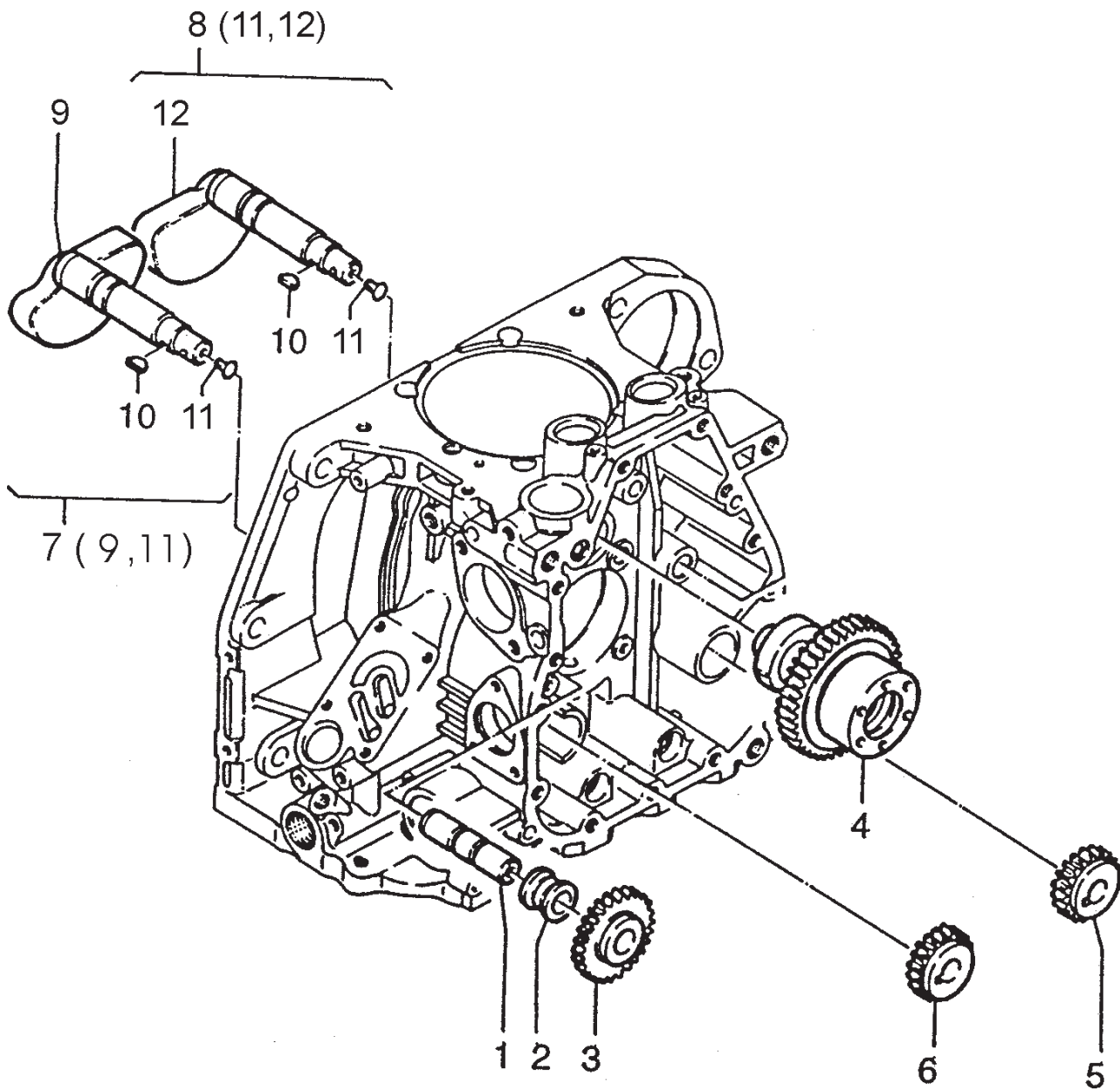

# HATZ 1D81Z ENGINE — CAMSHAFT ASSY.

## CAMSHAFT ASSY.

<u>NO.</u>	<u>PART NO.</u>	<u>PART NAME</u>	<u>QTY.</u>	<u>REMARKS</u>
1	03796400	SHAFT	2	
2	03796500	BUSH	2	
3	01242000	GEARWHEEL	2	
4	04099900	CAMSHAFT	1	
5	03796800	GEARWHEEL	1	
6	03796900	GEARWHEEL	1	
7	01267300	SHAFT, PUMP SIDE .....	1	INCLUDES ITEMS W/★
8	01267200	SHAFT STARTER SIDE .....	1	INCLUDES ITEMS W/#
9★		COUNTER BALANCE .....	1	CANNOT BE PURCHASED SEPARATELY
10	50324900	WOODRUFF KEY 3 X 3.7	2	
11★#		PIN .....	2	CANNOT BE PURCHASED SEPARATELY
12#		COUNTERBALANCE .....	1	CANNOT BE PURCHASED SEPARATELY

# HATZ 1D81Z ENGINE — PISTON/RINGS ASSY.

PISTON/RINGS ASSY.

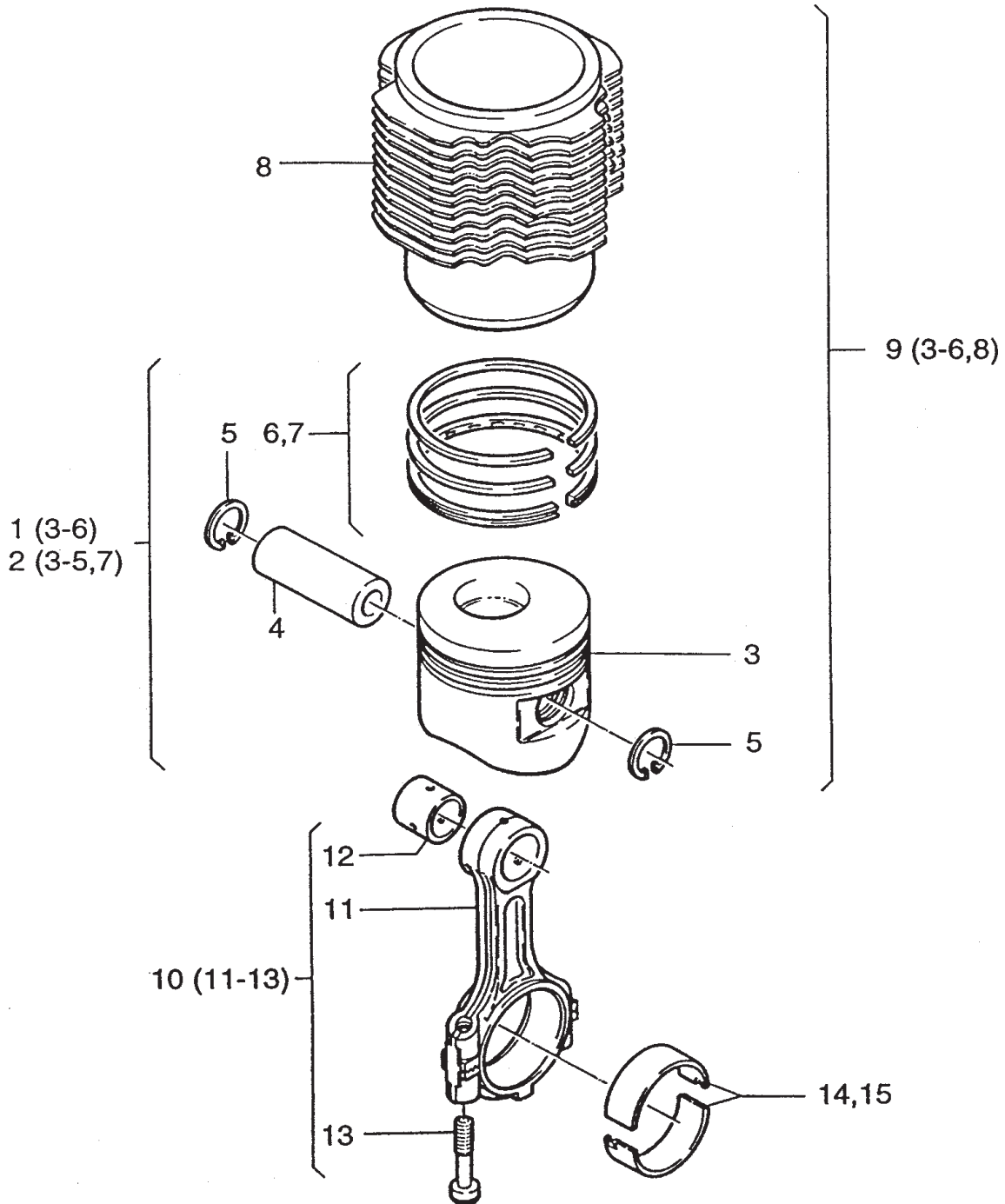

# HATZ 1D81Z ENGINE — PISTON/RINGS ASSY.

## PISTON/RINGS ASSY.

<u>NO.</u>	<u>PART NO.</u>	<u>PART NAME</u>	<u>QTY.</u>	<u>REMARKS</u>
1	01243901	PISTON ASSY. STD. ....	1	INCLUDES ITEMS W/*
1	01313510	PISTON ASSY. OVERSIZED .....	1	INCLUDES ITEMS W/*
2	01265101	PISTON ASSY. 100+0.5 .....	1	INCLUDES ITEMS W/#
2	01265201	PISTON ASSY. 100+1.0 .....	1	INCLUDES ITEMS W/#
2	01314610	PISTON ASSY. 100+0.5 .....	1	INCLUDES ITEMS W/#
2	01314710	PISTON ASSY. 100+1.0 .....	1	INCLUDES ITEMS W/#
3*#+		PISTON .....	1	CANNOT BE PURCHASED SEPARATELY
4*#+	50353600	WRIST PIN	1	
5*#+	50020800	CIRCLIP 30 X 1.2	2	
6*+	01247300	PISTON RING SET 100	1	
7#	01264500	PISTON RING SET +0.5	1	
7#	01265000	PISTON RING SET +1.0	1	
8+		CYLINDER .....	1	CANNOT BE PURCHASED SEPARATELY
9	01508301	CYLINDER ASSY. W/ PISTON .....	1	INCLUDES ITEMS W/+
10	01244001	CONROD ASSY. ....	1	INCLUDES ITEMS W/%
11%		CONROD .....	1	CANNOT BE PURCHASED SEPARATELY
12%	04032200	BUSH FOR CONROD	1	
13%	04001800	CONROD SCREW	2	
14	04001900	BIG END BEARING	1	
15	04033100	ROD BEARING -0.5	1	

# HATZ 1D81Z ENGINE — CYLINDER HEAD ASSY.

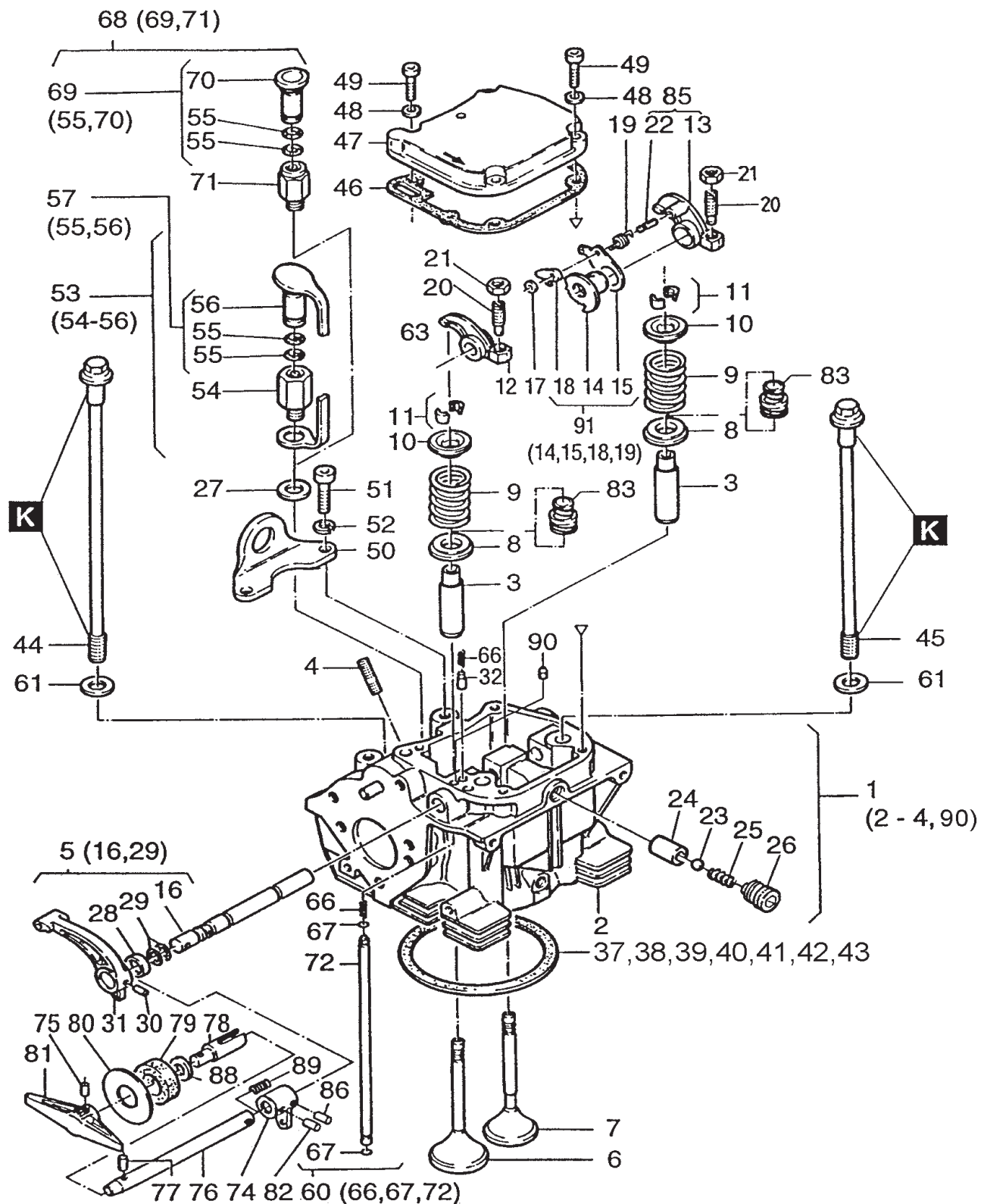

K= HOT TEMPERATURE FELT 100g

# HATZ 1D81Z ENGINE — CYLINDER HEAD ASSY.

## CYLINDER HEAD ASSY.

<u>NO.</u>	<u>PART NO.</u>	<u>PART NAME</u>	<u>QTY.</u>	<u>REMARKS</u>
1	01264810	CYLINDER HEAD ASSY.....	1	INCLUDES ITEMS W/*
1	01499610	CYLINDER HEAD ASSY.....	1	INCLUDES ITEMS W/*
2*		CYLINDER HEAD .....	1	CANNOT BE PURCHASED SEPARATELY
3*	04008710	VALVE GUIDE	2	
4*	50038400	STUD M 8 X 35	1	
5	04068910	ROCKER SHAFT ASSY. "C" .....	1	INCLUDES ITEMS W/+
5	04068920	ROCKER SHAFT ASSY.....	1	INCLUDES ITEMS W/+
6	04005001	VALVE INLET	1	
6	04091001	VALVE INLET	1	
7	04005101	VALVE EXHAUST	1	
7	04091100	VALVE EXHAUST	1	
8	04005201	WASHER	2	
9	04005300	VALVE SPRING	2	
10	04005401	CUP	2	
11	03786300	VALVE COLLET	2	
12	04003710	ROCKER INLET	1	
13#		ROCKER INLET .....	1	CANNOT BE PURCHASED SEPARATELY
14%		RATCHET WHEEL .....	1	CANNOT BE PURCHASED SEPARATELY
15%	03778401	SPRING SHEET	1	
16+		ROCKER SHAFT .....	1	CANNOT BE PURCHASED SEPARATELY
17	50117200	CIRCLIP	1	
18%	03365710	RATCHET F. DECOMPR.	1	
19	03366001	SPRING	1	
20	03783000	ADJUSTING SCREW	2	
21	03173100	HEXAGON NUT	2	
22#		DOWEL PIN .....	1	CANNOT BE PURCHASED SEPARATELY
23	50123800	BALL 7MM III	1	
24	04004700	BUSH	1	
25	04004800	PRESSURE SPRING	1	
26	01245200	ADJUSTING SCREW	1	
27	50001100	JOINT A 12 X 15.5	1	
28	04048900	RUBBER RING	1	
29+	40022401	O-RING 8 X 2 GRAY	1..2	
30	50034700	PIN 4 X 22	1	
31	04009810	HANDLE	1	
32	04004100	PIN	1	
35	04068800	GASK. F. CYL. HEAD 0.5	0..1	
36	04036800	GASK. F. CYL. HEAD 0.6	0..1	
37	04036500	GASK. F. CYL. HEAD 0.7	0..1	
38	04036600	GASK. F. CYL. HEAD 0.8	0..1	
39	04002700	GASK. F. CYL. HEAD 0.9	0..1	
40	04002800	GASK. F. CYL. HEAD 1.0	0..1	
41	04002900	GASK. F. CYL. HEAD 1.1	0..1	
42	04003000	GASK. F. CYL. HEAD 1.2	0..1	
43	04003100	GASK. F. CYL. HEAD 1.3	0..1	
44	04003200	CYL. HEAD SCREW 305 MM	2	
45	04003300	CYL. HEAD SCREW 258 MM	2	
46	04006111	VALVE COVER GASKET 16>	1	
47	01245410	VALVE COVER	1	
48	50081200	LOCK WASHER A6	4	
49	50170800	ALLEN SCREW M 6 X 25	4	
50	04008100	LIFTING BRACKET	1	

# HATZ 1D81Z ENGINE — CYLINDER HEAD ASSY.

## CYLINDER HEAD ASSY.

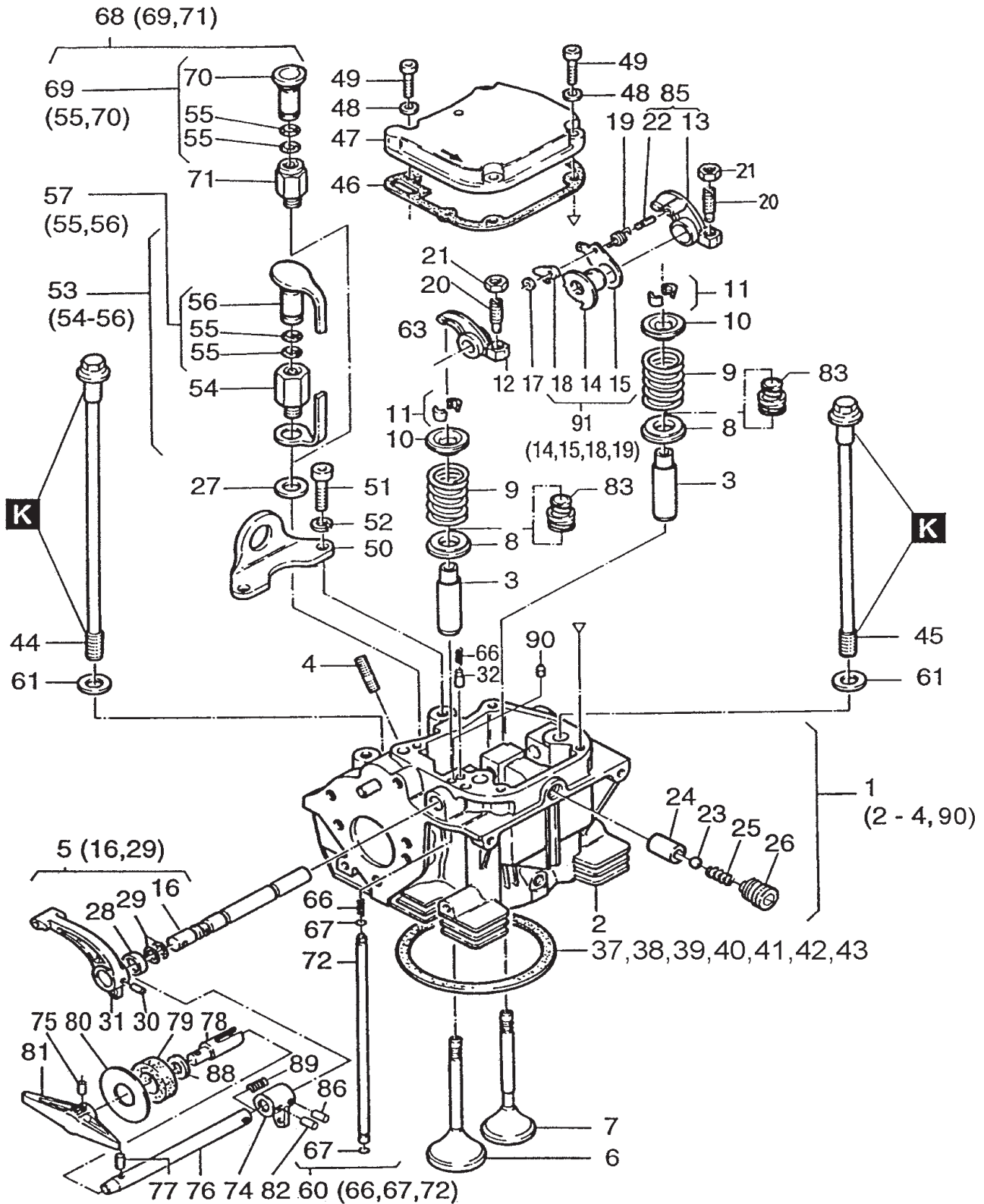

# HATZ 1D81Z ENGINE — CYLINDER HEAD ASSY.

## CYLINDER HEAD ASSY.

<u>NO.</u>	<u>PART NO.</u>	<u>PART NAME</u>	<u>QTY.</u>	<u>REMARKS</u>
51	50366300	ALLEN SCREW M 8X 20	2	
52	50208500	LOCK WASHER 8	2	
53	01493200	DEVICE HOUSING .....	1	INCLUDES ITEMS W/■
54■		HOUSING DEVICE BASE .....	1	CANNOT BE PURCHASED SEPARATELY
55■✓+	40081700	O-RING 12 X 16 X2	2	
56■✓		CAP .....	1	CANNOT BE PURCHASED SEPARATELY
57	01308300	CLOSING PLUG .....	1	INCLUDES ITEMS W/✓
60	01269700	OIL PRESSURE PIPE	1	INCLUDES ITEMS W/⊗
61	03457500	DISC F. STUD	4	
66⊗	04004200	PRESSURE SPRING	1	
67⊗	50330100	O-RING 4 X 1.2	2	
68	01280600	OIL FILTER DEVICE .....	1	INCLUDES ITEMS W/⊗
69⊗	01275610	CLOSING PLUG ASSY 46MM .....	1	INCLUDES ITEMS W/+
70+		CLOSING PLUG .....	1	CANNOT BE PURCHASED SEPARATELY
71⊗		TUBE .....	1	CANNOT BE PURCHASED SEPARATELY
72⊗		ROD .....	1	CANNOT BE PURCHASED SEPARATELY
74	04047920	INTERM. PIECE DECOMP.	1	
75	50132000	ROLL PIN 4 X 16	1	
76	04048220	DECOMPRESSION SHAFT "C"	1	
77	50034500	ROLL PIN 4 X 14	1	
78	04048110	INTERMEDIATE PIECE	1	
79	03579800	RUBBER WASHER	1	
80	04048000	WASHER 10.5 X 50 X 0.8	1	
81	03778200	HANDLE 6 X 18	1	
82	50132000	ROLL PIN 4 X 16	1	
83	50405200	VALVE STEM SEAL CAP	2	
85	01285010	ROCKER EXHAUST .....	1	INCLUDES ITEMS W/#
86	50034600	ROLL PIN 4 X 18	1	
88	03787300	SHIM 0.2	1	
89	04097200	PRES. SPRING DECOMPR.	1	
90*	04038500	OIL RESTRICTOR VALVE ASSY.	1	
90*	04104300	OIL RESTRICTOR VAVE	1	
91	01557600	GEARWHEEL F. DECOMPR. ....	1	INCLUDES ITEMS W/%

# HATZ 1D81Z ENGINE — FLYWHEEL ASSY.

FLYWHEEL ASSY.

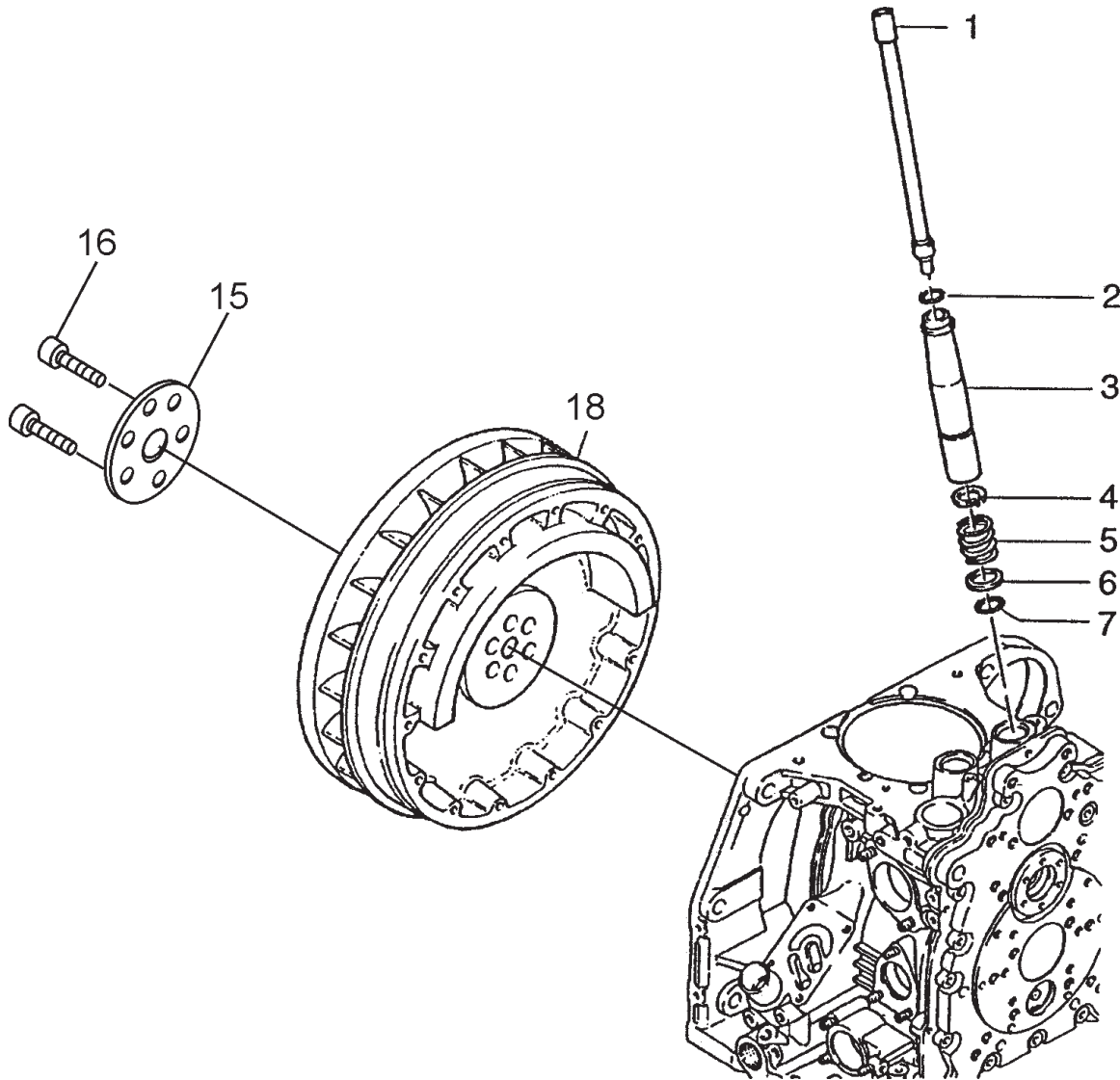

# HATZ 1D81Z ENGINE — FLYWHEEL ASSY.

## FLYWHEEL ASSY.

<u>NO.</u>	<u>PART NO.</u>	<u>PART NAME</u>	<u>QTY.</u>	<u>REMARKS</u>
1	01244310	PUSHROD	2	
2	50330200	O-RING 19 X 3N	2	
3	04002500	PROTECTION TUBE	2	
4	50347000	CIRCLIP AS 24 X 1.75	2	
5	04002000	PRESSURE SPRING	2	
6	04002000	PRESSURE RING	2	
7	50330300	O-RING 23 X 3	2	
15	04007410	PLATE	1	
16	50363100	ALLEN SCREW M 10 X 40	6	
18	04007131	FLYWHEEL , ELECTRIC START	1	

# HATZ 1D81Z ENGINE — OIL PUMP ASSY.

## OIL PUMP ASSY.

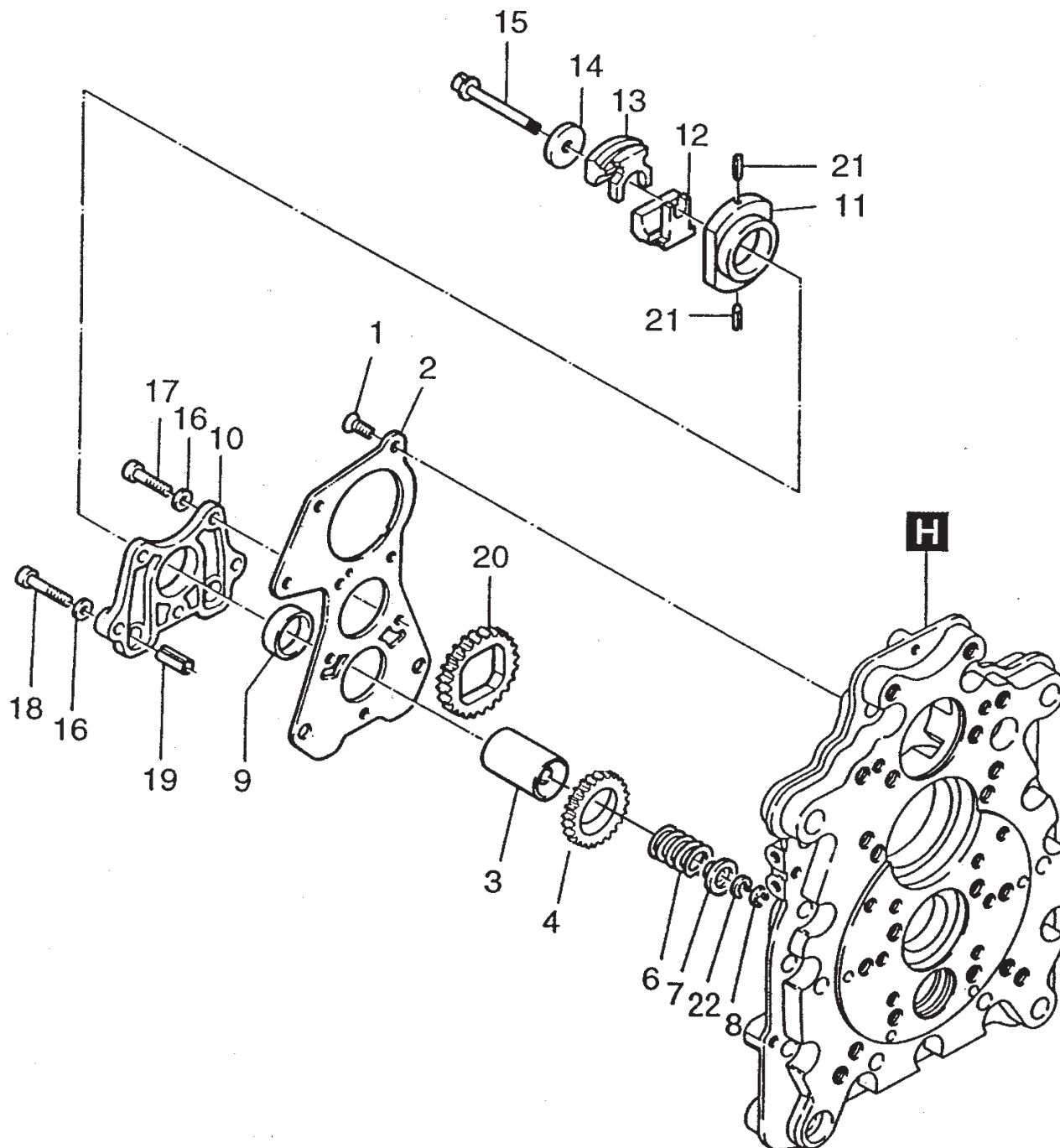

LETTERS IN BOLD INDICATE TYPE OF BONDING ADHESIVE TO BE USED.

D= LOCTITE 221 H= SILICON E= LOCTITE 648

# HATZ 1D81Z ENGINE — OIL PUMP ASSY.

## OIL PUMP ASSY.

<u>NO.</u>	<u>PART NO.</u>	<u>PART NAME</u>	<u>QTY.</u>	<u>REMARKS</u>
1	50328000	CTR. SUNK SCR.AM 6 X 16	5	
2	03797412	COVER F. OIL PUMP	1	
3	01242401	SPRING CAPSULE+BUSH	1	
4	03797310	GEARWHEEL	1	
6	04063400	GOVERNOR SPRING 2.9	1	
7	03798600	CUP	1	
8	50334700	CIRCLIP5	1	
9	03797600	BEARING BUSH	1	
10	03797510	HOUSING	1	
11	03797701	PLATE CENTRIF. WEIGHT	1	
12	03798002	CENTRIFUGAL WEIGHT	1	
13	03798102	CENTRIFUGAL WEIGHT	1	
14	03797900	WASHER	1	
15	03797801	PIN	1	
16	50081200	LOCK WASHER A6	5	
17	50170800	ALLEN SCREW M 6 X 25	3	
18	50051000	ALLEN SCREW M 6 X 30	2	
19	50084901	PIN 8 X 12	2	
20	03798720	GEARWHEEL	1	
21	50260501	ROLL PIN 2 X 10	2	
22	04046000	CIRCLIP	0.3	

# HATZ 1D81Z ENGINE — TIMING COVER ASSY.

TIMING COVER ASSY.

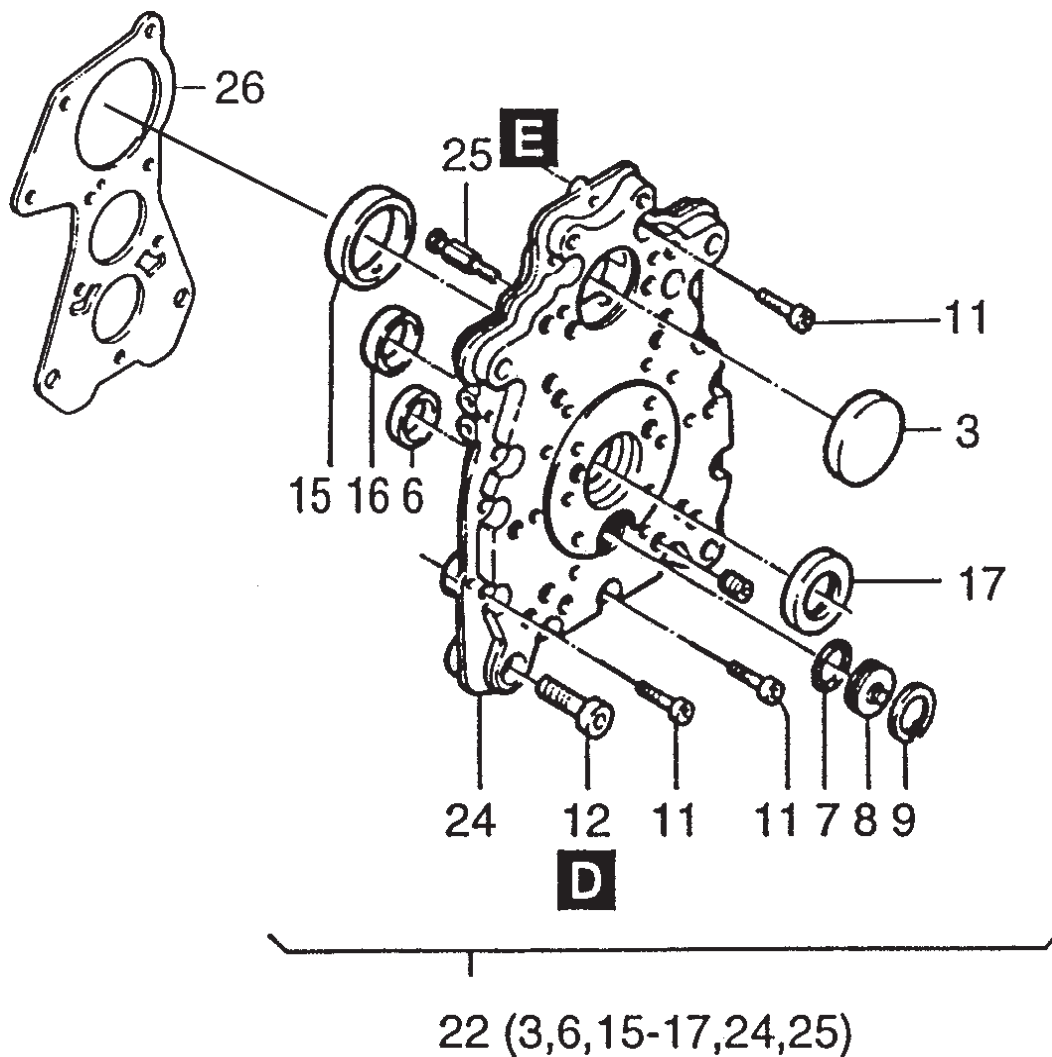

LETTERS IN BOLD INDICATE TYPE OF BONDING ADHESIVE TO BE USED.

D= LOCTITE 221 H= SILICON E= LOCTITE 648

# HATZ 1D81Z ENGINE — TIMING COVER ASSY.

## TIMING COVER ASSY.

<u>NO.</u>	<u>PART NO.</u>	<u>PART NAME</u>	<u>QTY.</u>	<u>REMARKS</u>
3#	05325600	COVER 50	1	
6#	03797600	BEARING BUSH	1	
7	50330400	O-RING 27 X 2N	1	
8	04000400	COVER	1	
9	50399000	CIRCLIP 32 X 1.2	1	
11	50417400	ALLEN SCREW M 8 X 30 Z3	13	
12	50329500	ALLEN SCREW M 12 X 40	1	
15#	04000310	BEARING BUSH	1	
16#	04023210	BEARING BUSH	1	
17#	50364700	OIL SEAL 32 X 52 X 7	1	
22	01281001	TIMING COVER ASSY. NO. 3 .....	1 .....	INCLUDES ITEMS W/#
24#		TIMING COVER .....	1 .....	CANNOT BE PURCHASED SEPARATELY
25#	04052400	NOZZLE	1	
26	03797412	COVER F. OIL PUMP	1	

# HATZ 1D81Z ENGINE — FUEL DEVICE ASSY.

## FUEL DEVICE ASSY.

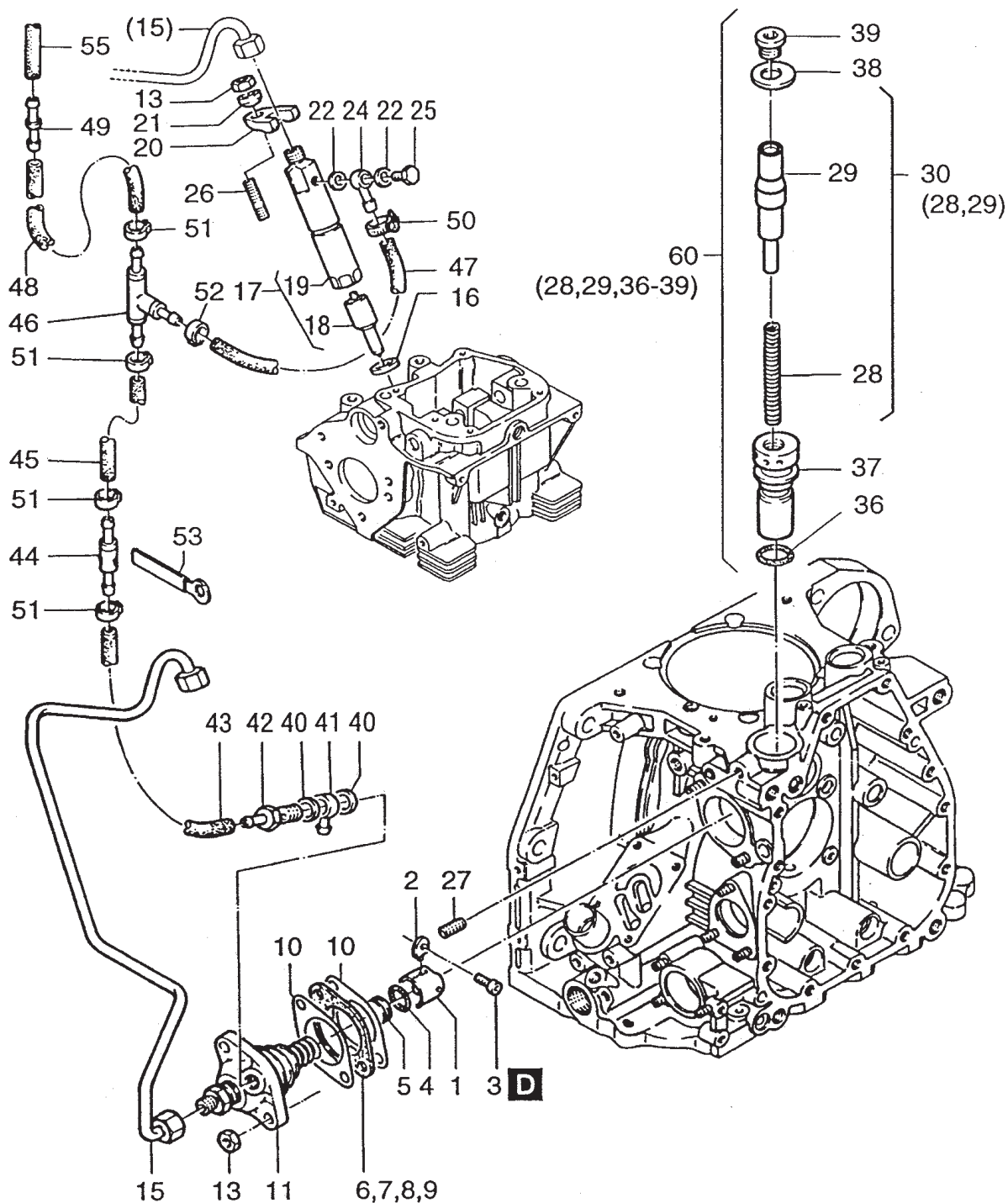

LETTERS IN BOLD INDICATE TYPE OF BONDING ADHESIVE TO BE USED.

D= LOCTITE 221 H= SILICON E= LOCTITE 648

# HATZ 1D81Z ENGINE — FUEL DEVICE ASSY.

## FUEL DEVICE ASSY.

<u>NO.</u>	<u>PART NO.</u>	<u>PART NAME</u>	<u>QTY.</u>	<u>REMARKS</u>
1	50331500	ROLLER TAPPET CPL.	1	
2	04000901	GUIDE	1	
3	50050700	ALLEN SCREW M 6 X 16	1	
4	50390200	O-RING 17 X 1.1	0..1	
4	50363400	O-RING 17 X 1.2	0..1	
5	04011700	PLATE	1	
6	03209700	SHIM 0.3	0..1	
7	04102400	SHIM 0.60/42.2	0..1	
8	04102500	SHIM 0.90/42.2	0..1	
9	04102600	SHIM 1.20/42.2	0..1	
10	04071300	GASKET	0.2	
10	04102200	GASKET INJECTION PUMP 0.2	0..2	
10	04102300	GASKET INJECTION PUMP 0.3	0..2	
11	50416200	INJECTION PUMP	1	
13	50148000	HEXAGON NUT M8	3	
15	01313600	FUEL PRESSURE PIPE	1	
16	04025800	JOINT WASHER	1	
16	40085001	INJECTOR SEAL	1	
17	50415101	INJECTOR .....	1	INCLUDES ITEMS W/%
18%	50415200	NOZZLE DLLA 154PV3	1	
19%		INJECTOR .....	1	CANNOT BE PURCHASED SEPARATELY
20	03792400	FLANGE	1	
21	04035700	WASHER	1	
22	50000800	COPPER WASHER	2	
24	50333400	BANJO UNION	1	
25	50313000	BANJO BOLT M6	1	
26	50038400	STUD M 8 X 35	1	
27	50004600	SET SCREW AM 8 X 16	1	
28*#	05035200	PRESSURE SPRING	1	
29*#		PIN .....	1	CANNOT BE PURCHASED SEPARATELY
30	01519500	PIST. + SPRG. EXT. FUEL .....	1	INCLUDES ITEMS W/*
36#	50328900	O-RING 22 X 1.6	1	
37#	04001410	CYL. F. EXTR. FUEL DEV.	1	
38#	04001600	DISC.	1	
39#	50330800	CLOS. SCREW M 16 X 1.5	1	
40	50001100	JOINT A12 X 15.5	2	
41	50015800	RING PIECE NW6	1	
42	03662300	PIPE NIPPLE	1	
43	04060400	FUEL HOSE 4.5 X 100	1	
44	00805500	VENT VALVE	1	
45	03807100	FUEL HOSE 4.5/150	1	
45	04060200	FUEL HOSE 4.5 X 55	1	
46	50157800	T-CONNECTION NW3	1	
47	03902000	FUEL PIPE 390	1	
48	05029600	FUEL HOSE 4.5/850	1	
49	50279600	CONNECTING NIPPLE	1	
50	50357200	HOSE CLIP 5SKZ	2	
51	50399801	CLAMP 11.3	4	
52	50399900	CLAMP 9.5	1	
53	01459700	CLIP	1	
60	01498902	PIST. + CYL. EXTR. FUEL .....	1	INCLUDES ITEMS W/#

# HATZ 1D81Z ENGINE — AIR DUCTING ASSY.

## AIR DUCTING ASSY.

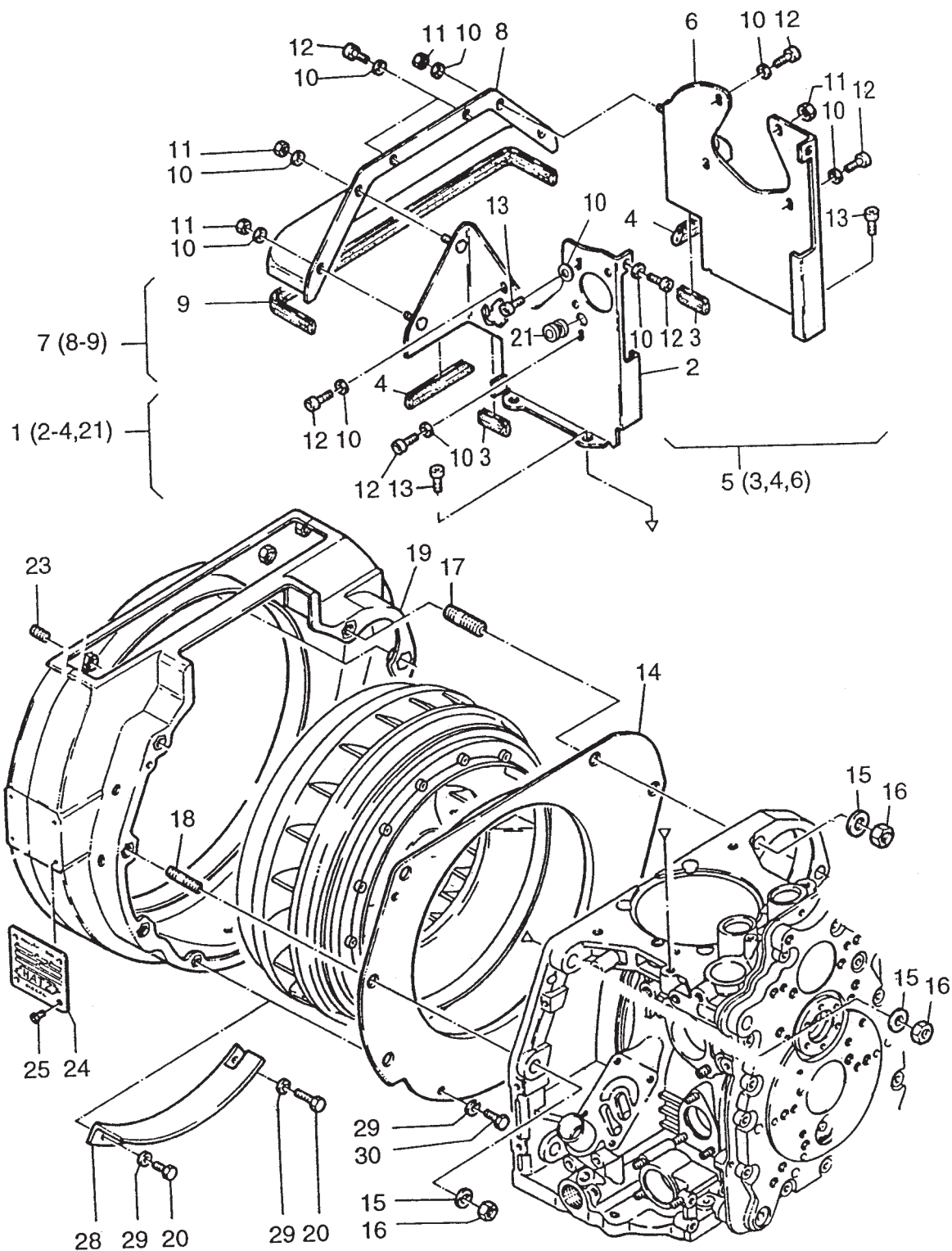

# HATZ 1D81Z ENGINE — AIR DUCTING ASSY.

## AIR DUCTING ASSY.

<u>NO.</u>	<u>PART NO.</u>	<u>PART NAME</u>	<u>QTY.</u>	<u>REMARKS</u>
1	01246220	COOLING AIR DUCT ASSY .....	1 .....	INCLUDES ITEMS W/*
2*		COOLING AIR DUCT .....	1 .....	CANNOT BE PURCHASED SEPARATELY
3*%	04007601	SEALING STRIP 32.2MM	2	
4*%	04007720	SEALING STRIP 76MM	2	
5	01246411	COOLING AIR DUCT .....	1 .....	INCLUDES ITEMS W/%
6%		SIDE SHROUD .....	1 .....	CANNOT BE PURCHASED SEPARATELY
7	01246600	COOLING AIR DUCT ASSY. ....	1 .....	INCLUDES ITEMS W/#
8#		COOLING AIR DUCT .....	1 .....	CANNOT BE PURCHASED SEPARATELY
9#	04007901	SEALING STRIP 413MM	1	
10	50081200	LOCK WASHER A6	15	
11	50144400	HEXAGON NUT M6	4	
12	50149100	ALLEN SCREW M6 X 12	12	
13	50206300	ALLEN SCREW M8 X 18	4	
14	04008500	PARTING SHEET	1	
15	50093700	FLAT WASHER A13	6	
16	50093600	HEXAGON NUT M12	6	
17	50364900	STUD M12 X 40	2	
18	50331400	STUD M12 X 35	4	
19	04008211	INTERMED. HOUSING	1	
20	50333500	HEXSCREW M 6 X 8	2	
21*	50334800	RUBBER SLEEVE	1	
23	50226000	GRUB SCREW M 8 X 6	4	
24	03225504	NAME PLATE	1	
25	40002500	POP RIVET 2.4 MM	4	
28	04080400	COVER F. BLOW DUCTING	1	
29	50170900	LOCK WASHER 6	4	
30	50177100	HEXSCREW M 6 X 16	2	

# HATZ 1D81Z ENGINE — BREATHER ASSY.

BREATHER ASSY.

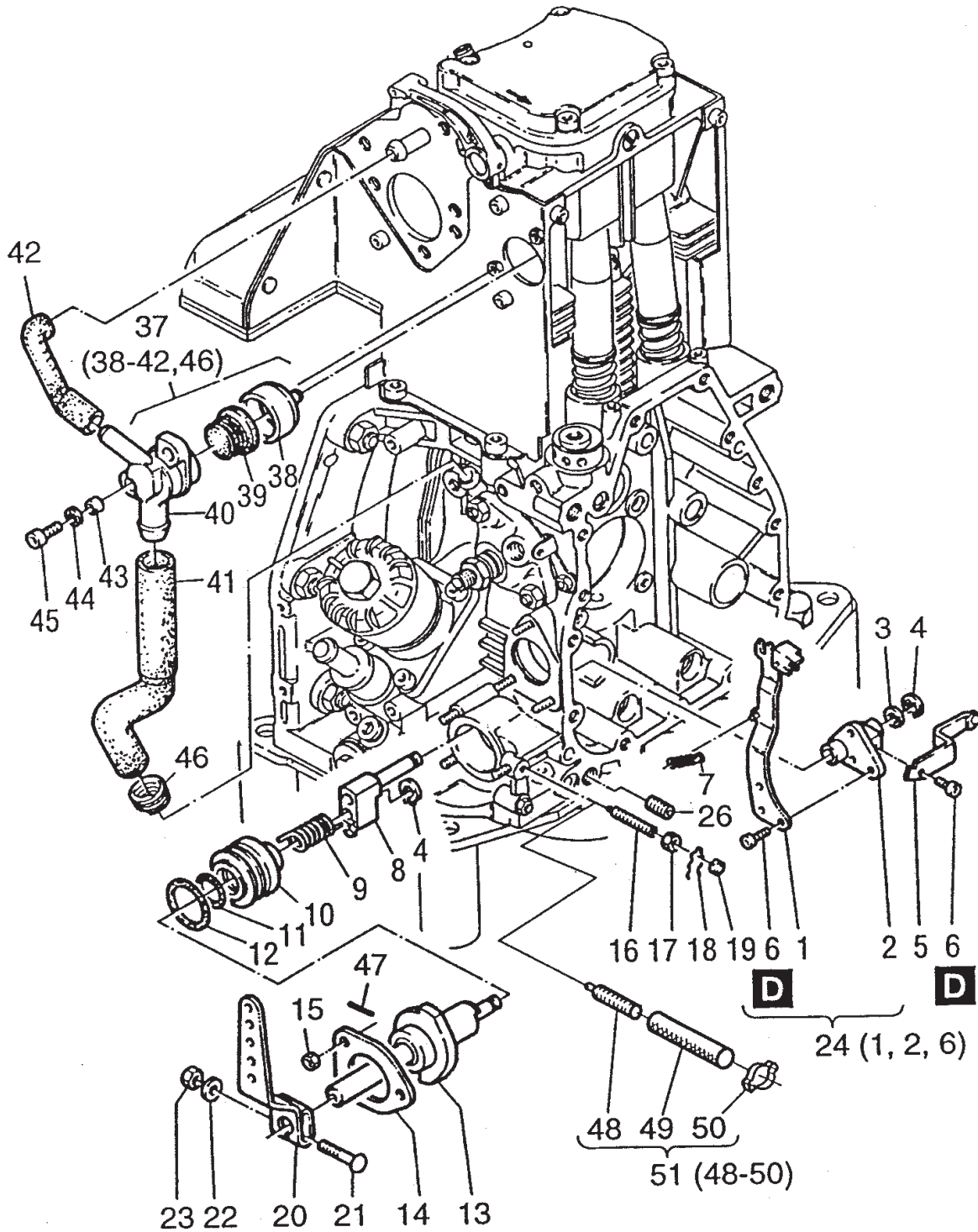

LETTERS IN BOLD INDICATE TYPE OF BONDING ADHESIVE TO BE USED.

D= LOCTITE 221 H= SILICON E= LOCTITE 648

# HATZ 1D81Z ENGINE — BREATHER ASSY.

## BREATHER ASSY.

<u>NO.</u>	<u>PART NO.</u>	<u>PART NAME</u>	<u>QTY.</u>	<u>REMARKS</u>
1#		THROTTLE ARM .....	1 .....	CANNOT BE PURCHASED SEPARATELY
2#		THROTTLE LINKAGE .....	1 .....	CANNOT BE PURCHASED SEPARATELY
3	04000100	SHIM	1	
4	50266100	CIRCLIP 6	2	
5	04037500	LEVER	1	
6#	50328701	ALLEN SCREW M 5 X 8	4	
7	04000200	TENSION SPRING	1	
8	01242810	GUIDE	1	
9	03799010	THIGH SPRING	1	
10	04052700	SPACER RING	1	
11	50386100	O-RING 21 X 2	1	
12	50129900	O-RING 32 X 37 X 2.5	1	
13	01279210	STOP RING SPD. CONT. S	1	
13	01302910	STOP RING SPD. CONT. C	1	
14	03799210	FRICITION PLATE	1	
15	50328300	HEXAGON NUT M6	3	
16	03799400	GRUB SCREW	2	
17	50144400	HEXAGON NUT M6	2	
18	40021500	SEAL WIRE 0.5-0.3	2	
19	40021400	LEAD SEAL 8MM	2	
20	03888300	THROTTLE LEVER	1	
21	03927300	SCREW M 6 X 32	1	
22	50144500	FLAT WASHER 6.4	1	
23	50144400	HEXAGON NUT M6	1	
24	01246801	GOVERNOR LEVER ASSY. ....	1 .....	INCLUDES ITEMS W/#
26	50403500	GRUB SCREW M 8 X 20	1	
37	01317000	BREATHER VALVE ASSY. ....	1 .....	INCLUDES ITEMS W/%
38%	04080300	BREATHER CUP	1	
39%	03568700	RUBBER DIAPHRAM	1	
40%		BREATHER .....	1 .....	CANNOT BE PURCHASED SEPARATELY
41%	04074700	BREATHER HOSE	1	
42%	04074800	BREATHER HOSE	1	
43	04080500	BUSH	2	
44	50081200	LOCK WASHER A6	2	
45	50170700	ALLEN SCREW M 6 X 16	2	
46%	04090500	CLIP	1	
47	50411500	SET PIN	1	
48*	50405301	GRUB SCREW M 6 X 45	1	
49*	05038000	HOSE 7 X 12 X 120	1	
50*	50388300	HOSE CLAMP	1	
51	01475600	ADJUST. SCREW ID 1D81 .....	1 .....	INCLUDES ITEMS W/*

# HATZ 1D81Z ENGINE — FUEL TANK ASSY.

## FUEL TANK ASSY.

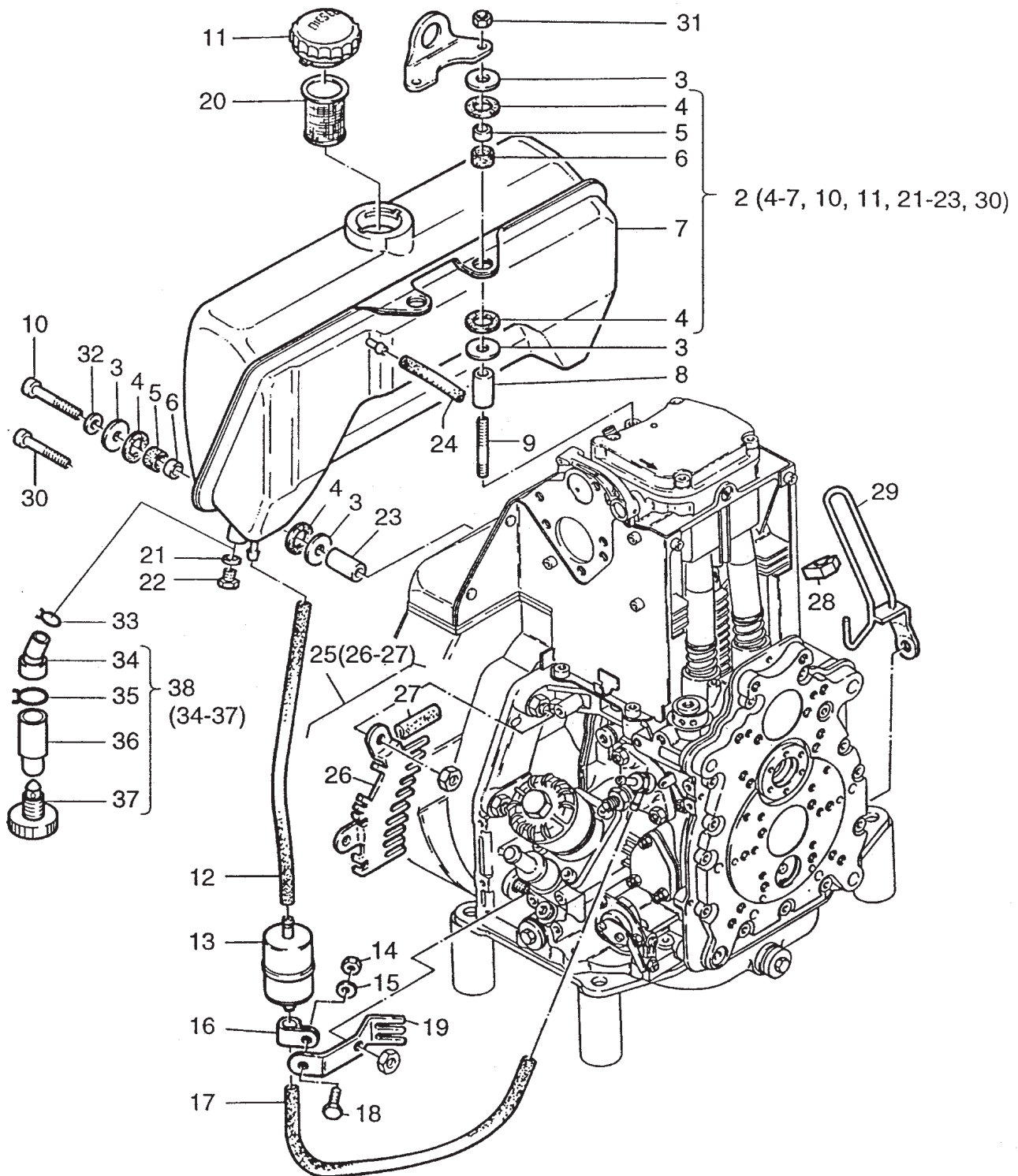

# HATZ 1D81Z ENGINE — FUEL TANK ASSY.

## FUEL TANK ASSY.

<u>NO.</u>	<u>PART NO.</u>	<u>PART NAME</u>	<u>QTY.</u>	<u>REMARKS</u>
2	01494200	FUEL TANK ASSY ( 7 LTRS.) .....	1 .....	INCLUDES ITEMS W/#
3	05097600	WASHER	12	
4#	03981802	RUBBER WASHER	12	
5#	03981701	BUSH 8.4 X 13 X 7.5	6	
6#	03981900	RUBBER SHELL	6	
7#		FUEL TANK .....	1 .....	CANNOT BE PURCHASED SEPARATELY
8	03989800	BUSH 8.5 X 20 X 49	2	
9	50377001	STUD M 8 X 75	2	
10#	50177500	ALLEN SCREW M 8 X 40	4	
11#	50385800	CAP, FUEL TANK	1	
12	03801200	FUEL HOSE 7/220	1	
13	50478800	FUEL FILTER .....	1 .....	REPLACES 40089401
14	50144400	HEXAGON NUT M6	1	
15	50144500	FLAT WASHER 6.4	1	
16	03165500	PIPE CLIP	1	
17	03493600	FUEL HOSE 7/330	1	
18	50165500	HEXSCREW M 6 X 12	1	
19	05031900	GUARD	1	
20	50387300	SIEVE	1	
21#	50001000	JOINT A 10 X 16	1	
22#	50359800	HEXSCREW M 10 X 12	1	
23#	05029200	BUSH 9 X 18 X 8	4	
24	03663700	FUEL PIPE L W 4.5 X 50	1	
25	01490300	PROTEC. GUARD TOP .....	1 .....	INCLUDES ITEMS W/%
26%		FINGER GUARD .....	1 .....	CANNOT BE PURCHASED SEPARATELY
27%	04030901	SEALING STRIP 29 MM	1	
28	03150900	CLAMP	1	
29	01402200	GUARD	1	
30#	50183000	ALLEN SCREW M 8 X 35	4	
31	50148000	HEXAGON NUT M8	2	
32	50208500	LOCK WASHER 8	4	
33	05045300	CLAMP 21 MM	1	
34*	05044001	HOSE 10/12 MM	1	
35*	05036900	HOSE CLIP	1	
36*	05043900	WATER SEPARATOR	1	
37*	50414800	CLOS. SCREW M 10	1	
38	01519401	WATER SEPARATOR .....	1 .....	INCLUDES ITEMS W/*

# HATZ 1D81Z ENGINE — FUEL PUMP ASSY.

FUEL PUMP ASSY.

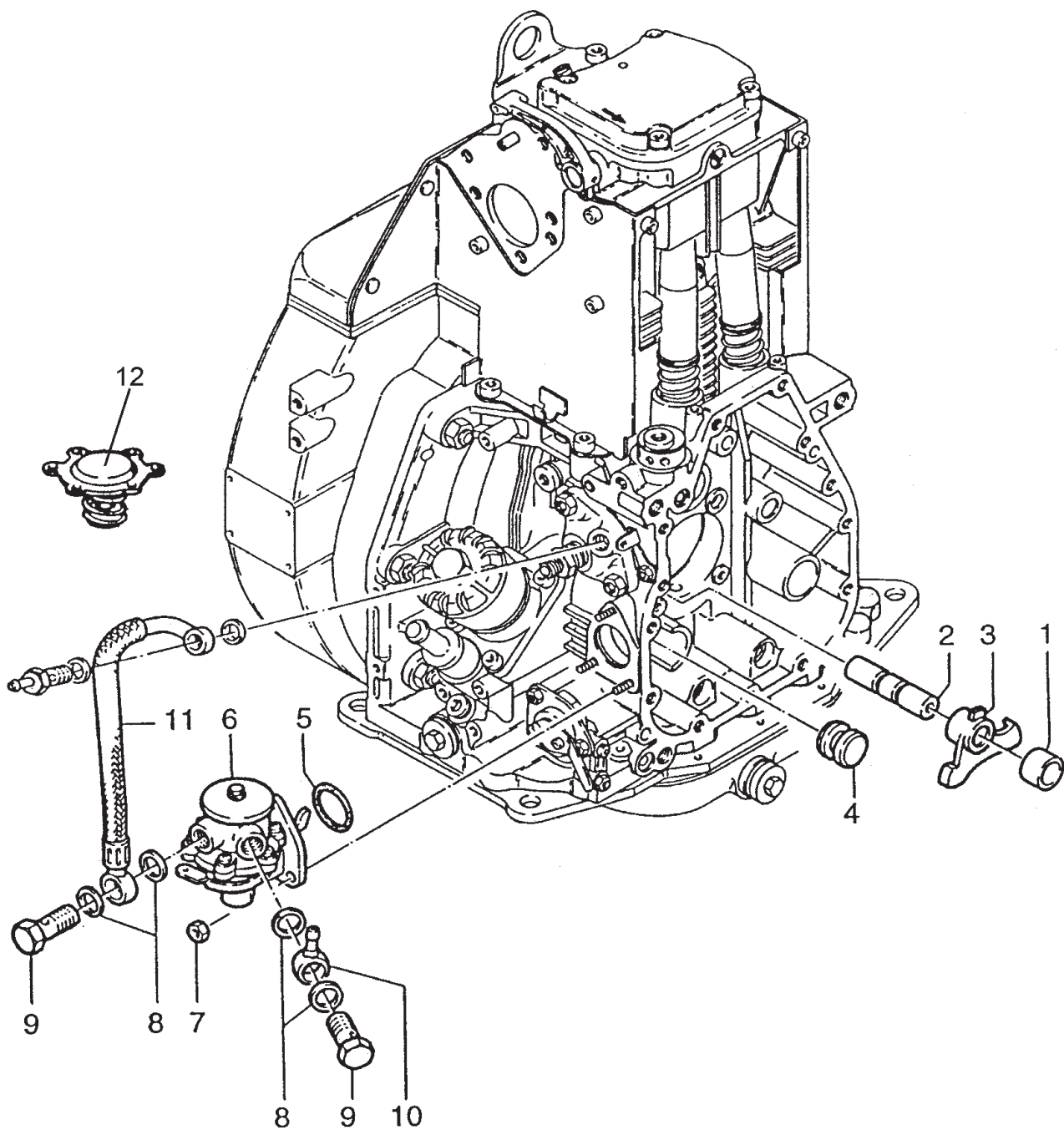

# HATZ 1D81Z ENGINE — FUEL PUMP ASSY.

## FUEL PUMP ASSY.

<u>NO.</u>	<u>PART NO.</u>	<u>PART NAME</u>	<u>QTY.</u>	<u>REMARKS</u>
1	04011900	BUSH	1	
2	03796400	SHAFT	1	
3	04011801	LEVER F. FEED PUMP	1	
4	04000800	PLUG	1	
5	50331800	O-RING	1	
6	50332301	FUEL FEED PUMP	1	
7	50328300	HEXAGON NUT M6	3	
8	50001200	JOINT A 14 X 18	4	
9	50006400	BANJO BOLT A8	2	
10	50015900	RING PIECE N W 8	1	
11	01468801	FUEL PIPE	1	
12	49062501	DIAPHRAM	1	

# HATZ 1D81Z ENGINE — AIR FILTER ASSY.

AIR FILTER ASSY.

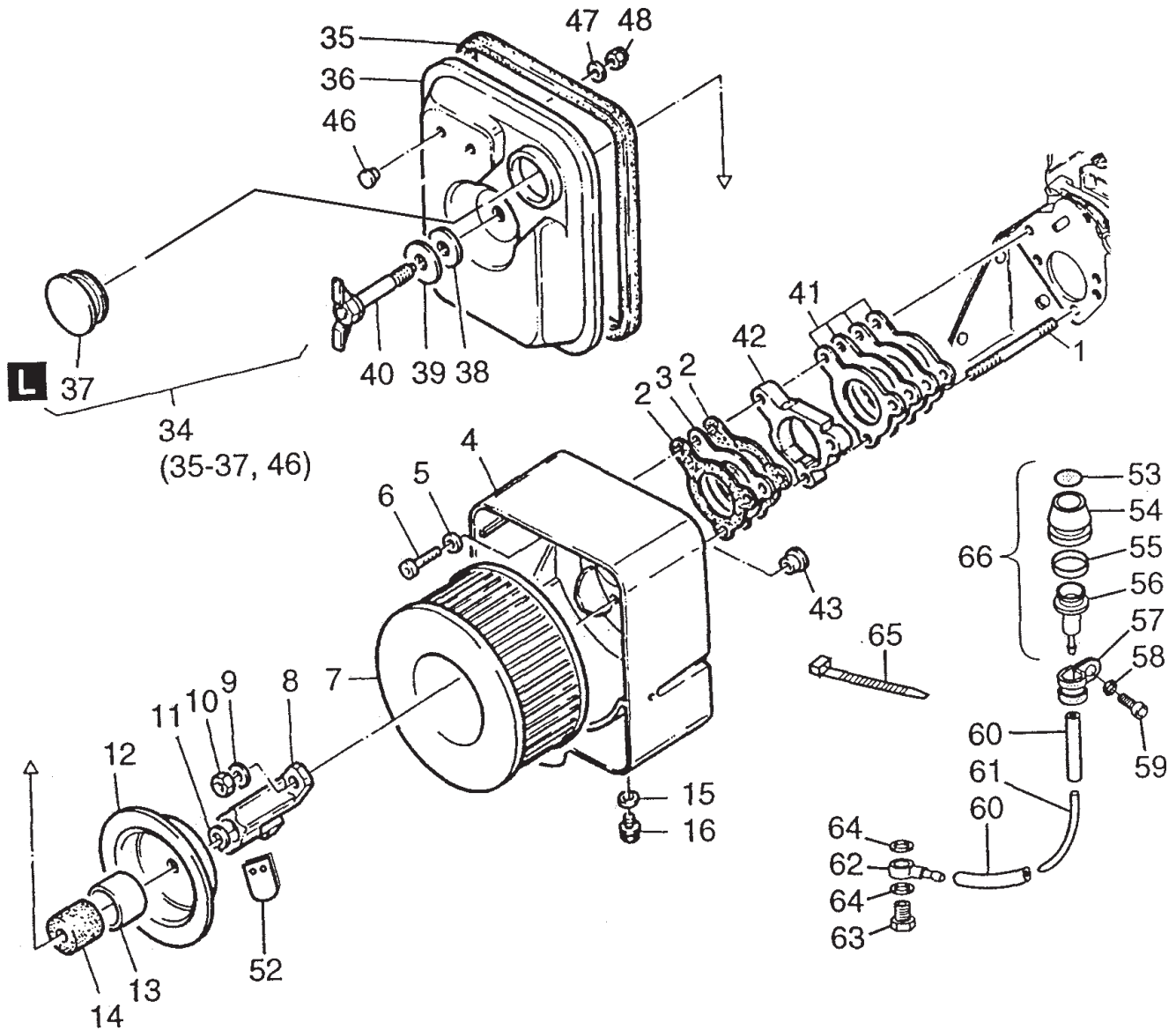

L= SILICON SEALER

# HATZ 1D81Z ENGINE — AIR FILTER ASSY.

## AIR FILTER ASSY.

<u>NO.</u>	<u>PART NO.</u>	<u>PART NAME</u>	<u>QTY.</u>	<u>REMARKS</u>
1	50038900	STUD M 8 X 60	2	
2	04006300	GASKET	2	
3	04006200	INSULATING FLANGE	1	
4	04004312	AIRFILTER HOUSING	1	
5	50095100	LOCK WASHER A8	1	
6	50398400	CYLINDER HEAD BOLT	1	
7	01493000	AIR FILTER	1	
8	01483400	RETAINING STRAP	1	
9	50148100	FLAT WASHER 8.4	2	
10	50129500	HEXAGON NUT M8	2	
11	50412000	CIRCLIP 10 X 1	1	
12	05036400	CENTERING COVER	1	
13	05039300	BUSH 33 X 35 X 23.5	1	
14	03579400	SEALING RING	1	
15	50062400	JOINT A 10 X 13.5	1	
16	50062300	CLOSING SCREW M 10 X 1	1	
34	01496800	COVER AIRFILTER .....	1	INCLUDES ITEMS W/*
35*	04047701	SEALING STRIP LG 704	1	
37*	05039401	CLOSING CAP	1	
36*		CLOSING COVER .....	1	CANNOT BE PURCHASED SEPARATELY
38	03814100	INSULATING DISC	1	
39	05038700	WASHER 11 X 36 X 3	1	
40	01490800	WING SCREW	1	
41	01287900	GASKET AIRFILTER	1	
42	04047300	INTERMEDIATE FLANGE	1	
43	50395700	COVER 15	1	
46*	50411900	CLOSING PLUG 7	2	
47	50120000	DISC A 6.4	2	
48	40028300	HEXAGON NUT M 6	2	
52	05033500	VALVE PLATE	1	
53#	05044501	INDIC. PLATE	1	
54#	05043601	RUBBER CAP	1	
55#	05045600	SIGNAL RING	1	
56#	05043700	ADAPTER	1	
57	50173500	PIPE CLIP	1	
58	50170900	LOCK WASHER 6	1	
59	50170600	ALLEN SCREW M 6 X 20	1	
60	03961400	FUEL HOSE 3.51-50	2	
61	05043800	HOSE 2 X 4 X 170	1	
62	50159500	RING PIECE N W 4	4	
63	50006200	BANJO BOLT A 4	1	
64	50062400	JOINT A 10 X 13.5	2	
65	50358400	STRAP	1	
66	01499800	MAINT. INDICATOR .....	1	INCLUDES ITEMS W/#

# HATZ 1D81Z ENGINE — EXHAUST SILENCER ASSY.

EXHAUST SILENCER ASSY.

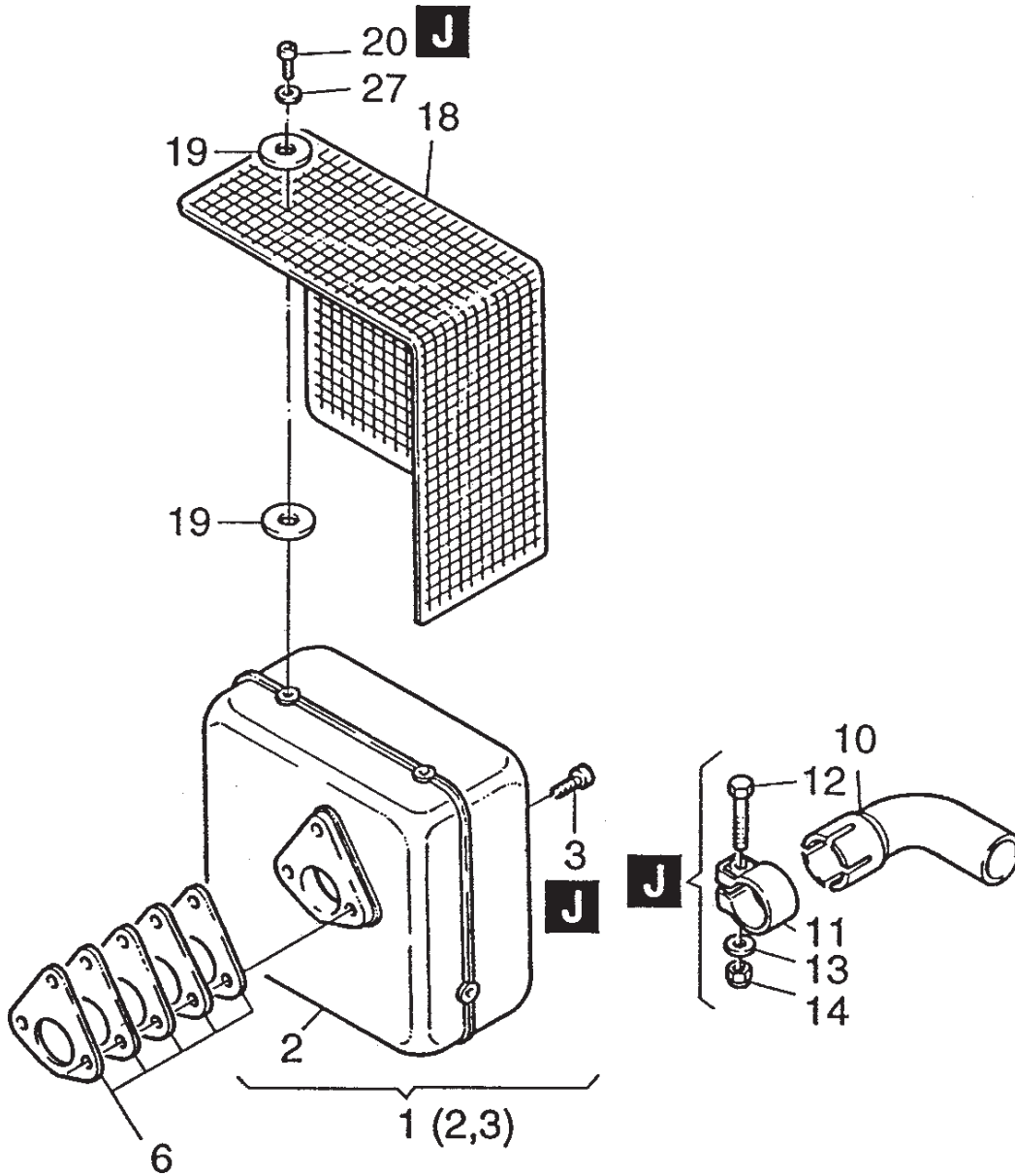

J= HOT TEMPERATURE PASTE

# HATZ 1D81Z ENGINE — EXHAUST SILENCER ASSY.

## EXHAUST SILENCER ASSY.

<u>NO.</u>	<u>PART NO.</u>	<u>PART NAME</u>	<u>QTY.</u>	<u>REMARKS</u>
1	01498800	EXHAUST SILENCER S ASSY. ....	1	INCLUDES ITEMS W/*
2*		EXHAUST SILENCER .....	1	CANNOT BE PURCHASED SEPARATELY
3*	50404000	ALLEN SCREW M 8 X 30	3	
6	01471110	GASKET SET EXHAUST SIL.	1	
10	03877300	ELBOW	1	
11	03877700	PIPE CLIP 52.5	1	
12	50249500	HEX SCREW M 10 X 50	1	
13	50145900	FLAT WASHER 10.5	1	
14	40028600	HEX NUT M 10	1	
16	03997100	EXHAUST TUBE	1	
18	01191901	MUFFLER GUARD ID	1	
19	05034200	LOCK WASHER	10	
20	50255700	ALLEN SCREW M 6 X 12	5	

# HATZ 1D81Z ENGINE — STARTER/ALTERNATOR ASSY.

## STARTER/ALTERNATOR ASSY.

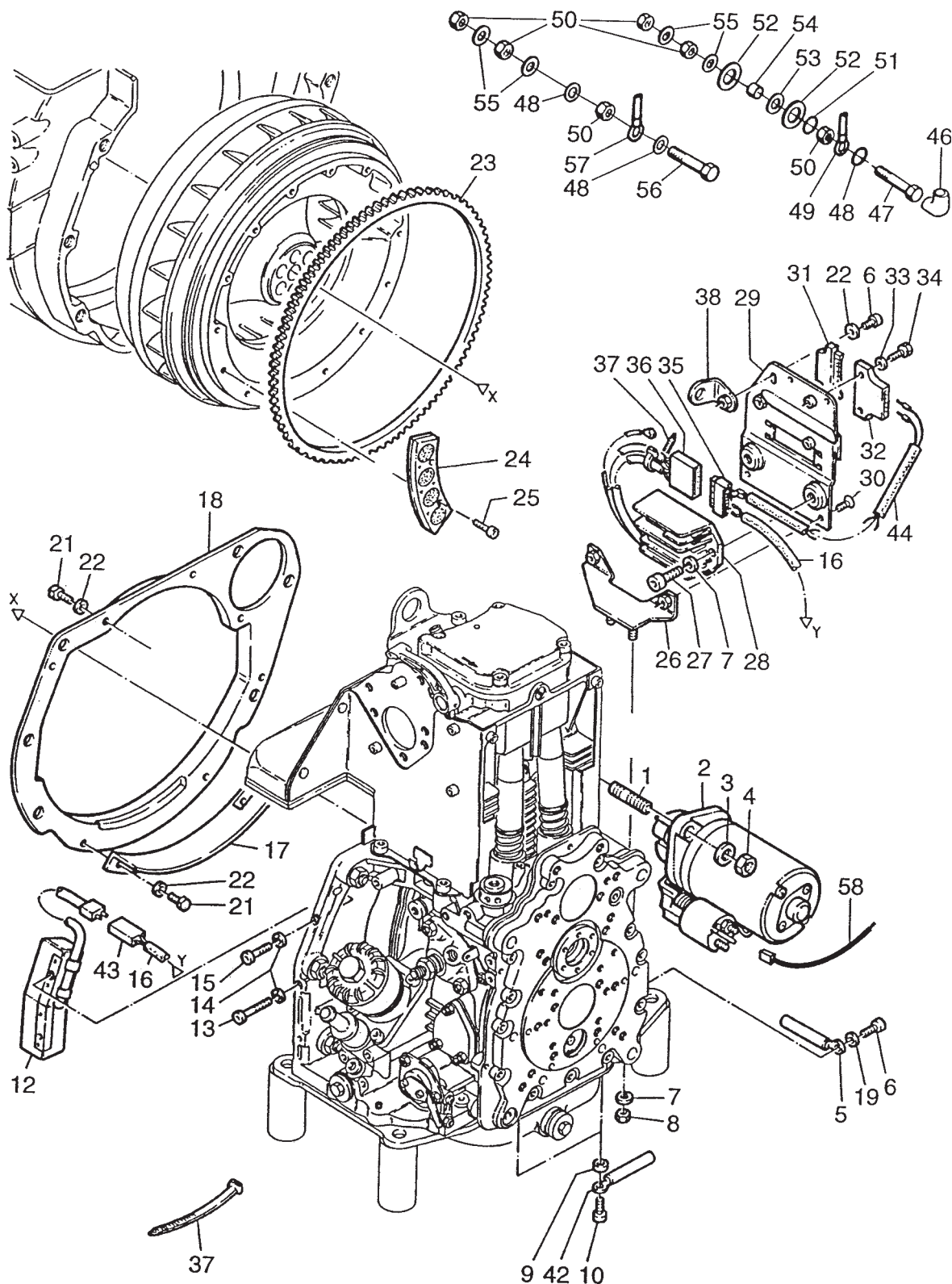

# HATZ 1D81Z ENGINE — STARTER/ALTERNATOR ASSY.

## STARTER/ALTERNATOR ASSY.

<u>NO.</u>	<u>PART NO.</u>	<u>PART NAME</u>	<u>QTY.</u>	<u>REMARKS</u>
1	50201200	STUD M 12 X 50	2	
2	50353420	STARTER 12 V 10 TOOTH	1	
3	50093700	FLAT WASHER A 13	2	
4	50380600	HEXAGON NUT M 12	2	
5	01459700	CLIP	2	
6	50149100	ALLEN SCREW M 6 X 12	2	
7	50208500	LOCK WASHER 8	4	
8	50148000	HEXAGON NUT M 8	2	
9	04021000	BUSH 6.3 X 12.15 X 5	2	
10	50170700	ALLEN SCREW M 6 X 16	2	
12	01439000	COIL WITH WIRE 12 V	1	
13	50401200	ALLEN SCREW M 6 X 35	1	
14	50165600	LOCK WASHER	2	
15	50236600	ALLEN SCREW M 6 X 25	1	
16	01462800	ELECTRIC WIRE	1	
17	04021100	PROTECT. ALTERNATOR	1	
18	04009920	PARTING SHEET	1	
19	50144500	FLAT WASHER 6.4	1	
21	50165500	HEXSCREW M 6 X 12	5	
22	50170900	LOCK WASHER 6	6	
23	04021210	GEAR RING 123 TEETH	1	
24	04020421	MAGNET SEGMENT	7	
25	50397100	ALLEN SCREW M 4 X 10	14	
26	01440300	SUPPORT	1	
27	50165400	ALLEN SCREW M 8 X 16	2	
28	01248121	REGULATOR 12 V	1	
28	01425021	REGULATOR 24 V	1	
29	01440100	FASTENING PLATE	1	
30	50380800	CTR. SUNK SCREW M 6 X 10	2	
31	50373700	PLUG SLEEVE HOUSING	1	
32	50373600	PIN TERM. HOUSING 6 WAY	1	
33	50216300	WASHER 5.3	2	
34	50335700	HEXSCREW M 5 X 25	2	
35	50402100	PLUG SLEEVE HOUSING	1	
36	50402000	PLUG SLEEVE HOUSING	1	
37	50358400	STRAP	4	
38	01440200	SUPPORT	1	
42	01470200	CLIP	2	
43	50379700	PLUG SLEEVE HOUSING	1	
44	01439400	WIRING HARNESS	1	
46	40026600	PROTECTION CAP. RUBBER	1	
47	50400300	HEXSCREW M 8 X 40	1	
48	50179900	STAR WASHER	1..2	
49	01430800	BATTERY CABLE PLUS	1	
50	50023000	HEXAGON NUT M 8	3	
51	50426900	SERRATED WASH. A 8.4	1	
52	03814100	INSULATING DISC	2	
53	50426800	TOOTH LOCK J 10.5	1	
54	03814200	INSULATING TUBE	1	
55	50016800	DISC 8.4	2	
56	50275300	HEXSCREW M 8 X 35	1	
57	01430900	BATTERY CABLE MINUS	1	
58	01193401	ELECTRIC WIRE	1	

# HATZ 1D81Z ENGINE — INSTRUMENT BOX ASSY.

## INSTRUMENT BOX ASSY.

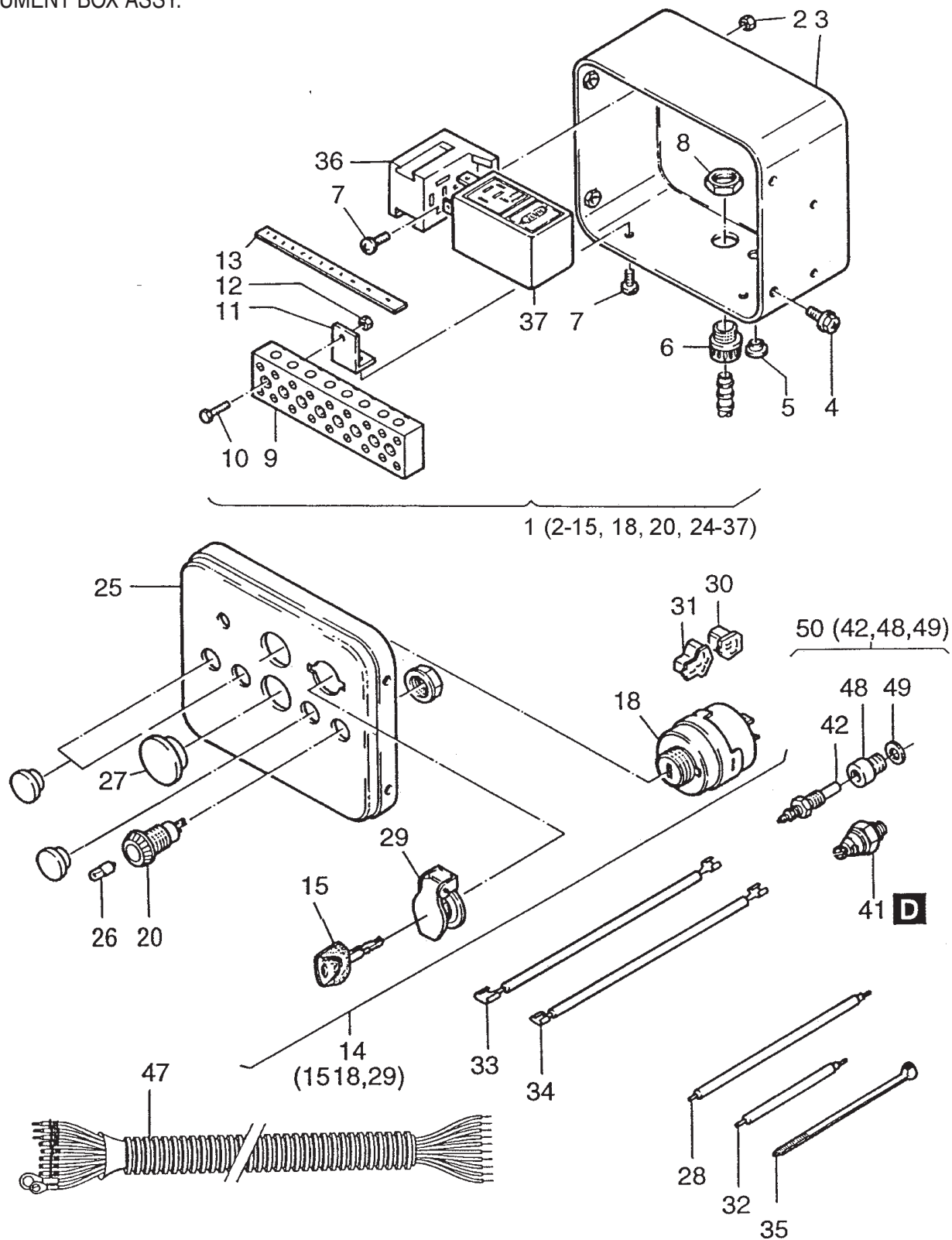

LETTERS IN BOLD INDICATE TYPE OF BONDING ADHESIVE TO BE USED.

D= LOCTITE 221 H= SILICON E= LOCTITE 648

# HATZ 1D81Z ENGINE — INSTRUMENT BOX ASSY.

## INSTRUMENT BOX ASSY.

<u>NO.</u>	<u>PART NO.</u>	<u>PART NAME</u>	<u>QTY.</u>	<u>REMARKS</u>
1	01407000	INSTRUMENT BOX 12 V .....	1	INCLUDES ITEMS W/*
1	01457700	INSTRUMENT BOX 24 V .....	1	INCLUDES ITEMS W/*
2*	40028200	HEX. NUT M5	1	
3*	00716311	INSRTUMENT BOX, ENCL.	1	
4*	50289200	HEXSCREW M 6 X 12	4	
5*	50160800	CLOSING PLUG, PLASTIC	1	
6*	50159010	MALE CABLE COUPLING	1	
7*	50049300	ALLEN SCREW M 5 X 10	3	
8*	50159100	HEXAGON NUT, PLASTIC	1	
9*	50160700	CONNECTING BLOCK	1	
10*	50158800	ALLEN SCREW M 4 X 20	2	
11*	03666700	BRACKET	2	
12*	50147100	HEXAGON NUT M 4	2	
13*	05004300	DECAL F. INST. BOX	1	
14*	50276502	GLOW START. SWITCH .....	1	INCLUDES ITEMS W/%
15*%	50345300	IGN. KEY DS 14603	1	
18%*		KEY SWITCH .....	1	CANNOT BE PURCHASED SEPARATELY
20*	50176501	INDICATOR LAMP, BATTERY	1	
21	50176600	INDICATOR LAMP, OIL	1	
22	50176400	INDICATOR LAMP, TEMP.	1	
24*	40096000	CLOSING PLUG	0..3	
25*	03509211	INSTRU. BOX FRONT	1	
26*	40009700	BULB 12 V - 2 W	0..4	
26*	40009800	BULB 24 V - 2 W	0..4	
27*	40091400	CLOSING PLUG, PLASTIC	0..2	
28*	01150101	DIODE ASSY.	1	
29*%	49050900	FLAP FOR SWITCHBOX	1	
30*	50276600	PLUG SLEEVE HOUSING	1	
31*	50276700	PLUG SLEEVE HOUSING	1	
32*	01090201	DIODE ASSY.	2	
33*	01089801	DIODE ASSY.	1	
34*	01089901	DIODE ASSY.	1	
35*	50358400	STRAP	1	
36*	50276000	RELAY SOCKET	1	
37*	50275802	MOTOR START RELAY	1	
37*	50275902	RELAY ENG. PROT. 24 V	1	
41	40021300	OIL PRESSURE SWITCH	1	
42#	50268600	TEMP. SWITCH	1	
47	01433601	WIRING HARNESS	1	
48#	05027800	INTERMED. PIECE. TEMP	1	
49#	50001000	JOINT A 10 X 16	1	
50	01475200	TEMP. SWITCH 12 V "C" .....	1	INCLUDES ITEMS W/#

# HATZ 1D81Z ENGINE — LIFTING MAGNET/STOPDEVICE ASSY.

LIFTING MAGNET/S TOP DEVICE ASSY.

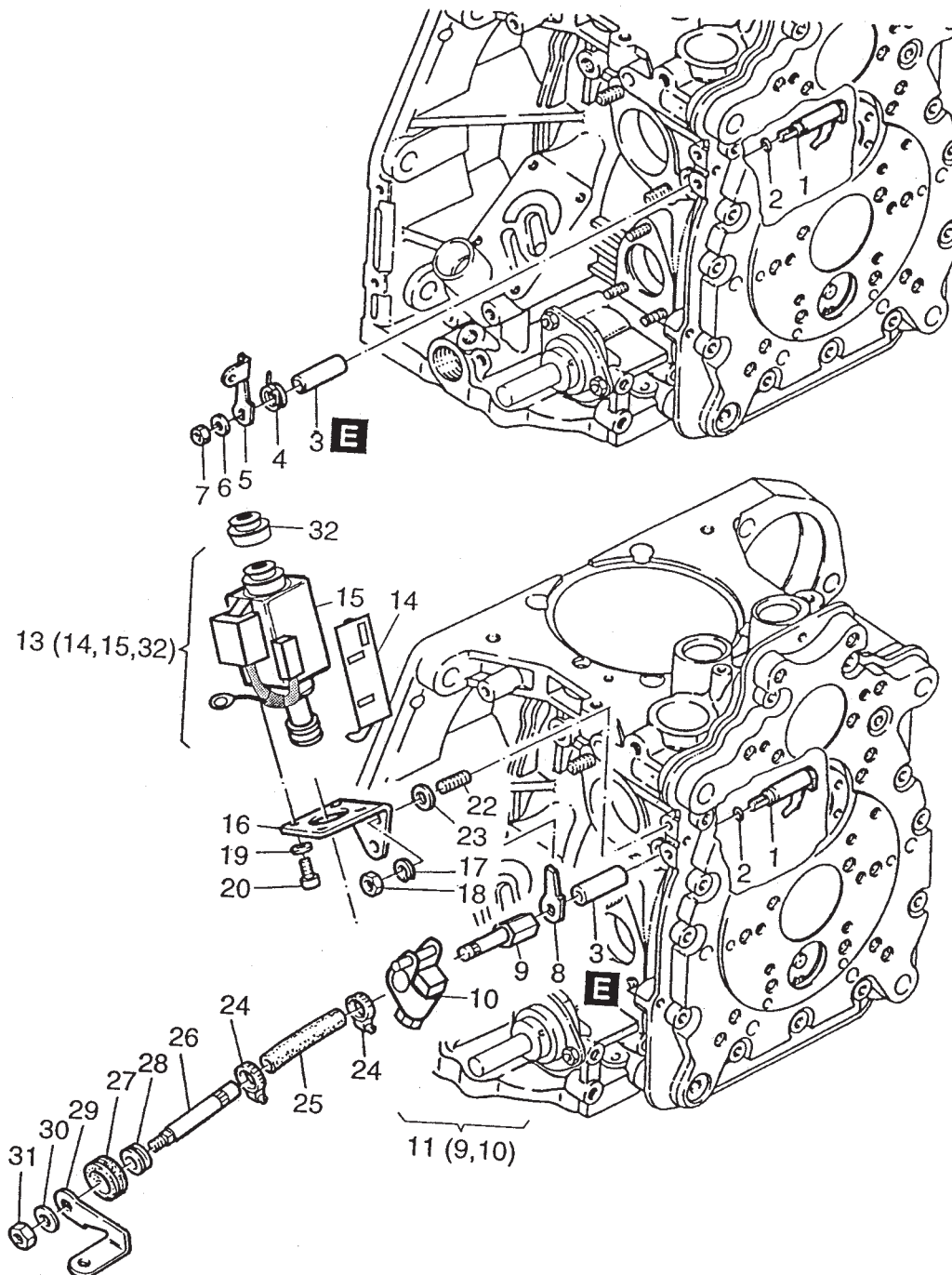

LETTERS IN BOLD INDICATE TYPE OF BONDING ADHESIVE TO BE USED.

D= LOCTITE 221 H= SILICON E= LOCTITE 648

# HATZ 1D81Z ENGINE — LIFTING MAGNET/STOPDEVICE ASSY.

## LIFTING MAGNET/STOP DEVICE ASSY.

<u>NO.</u>	<u>PART NO.</u>	<u>PART NAME</u>	<u>QTY.</u>	<u>REMARKS</u>
1	01254602	LEVER CPL.	1	
2	50343300	O-RING 4.6 X 1.85	1	
3	04021400	BUSH	1	
4	04021800	SPRING	1	
5	04021700	LEVER	1	
6	50144500	FLAT WASHER 6.4	1	
7	50328300	HEXAGON NUT M 6	1	
8	05015100	SUPPORT SOLENOID	1	
9#		BUSHING .....	1	CANNOT BE PURCHASED SEPARATELY
10#		LINKAGE .....	1	CANNOT BE PURCHASED SEPARATELY
11	01515300	SHAFT + LEVER STOPMAG .....	1	INCLUDES ITEMS W/#
13	01515500	LIFTING MAGNET 12 V .....	1	INCLUDES ITEMS W/*
14*	05058400	CABLE HOLDER	1	
15*		STOP MAGNET .....	1	CANNOT BE PURCHASED SEPARATELY
16	05023501	CONSOLE	1	
17	50170900	LOCK WASHER 6	2	
18	50144400	HEXAGON NUT M 6	2	
19	50216300	WASHER 5.3	3	
20	50112600	ALLEN SCREW M 5 X 10	4	
22	50366800	STUD M 6 X 12	2	
23	50114300	DISC 6.4	2	
24	40037300	CLAMP 8-12	2	
25	03999001	FUEL HOSE 7/70	1	
26	03996600	SHAFT	1	
27	03565400	RUBBER SLEEVE	1	
28	05069200	BUSH F. BELT TENSION	1	
29	04021700	LEVER	1	
30	50144500	WASHER	1	
31	50328300	HEXAGON NUT M6	1	
32*	50248900	BELLOWS	1	

**PAYMENT TERMS**

Terms of payment for parts are net 30 days.

**FREIGHT POLICY**

All parts orders will be shipped collect or prepaid with the charges added to the invoice. All shipments are F.O.B. point of origin. Multiquip's responsibility ceases when a signed manifest has been obtained from the carrier, and any claim for shortage or damage must be settled between the consignee and the carrier.

**MINIMUM ORDER**

The minimum charge for orders from Multiquip is \$15.00 net. Customers will be asked for instructions regarding handling of orders not meeting this requirement.

**RETURNED GOODS POLICY**

Return shipments will be accepted and credit will be allowed, subject to the following provisions:

1. A Returned Material Authorization must be approved by Multiquip prior to shipment.
2. To obtain a Return Material Authorization, a list must be provided to Multiquip Parts Sales that defines item numbers, quantities, and descriptions of the items to be returned.
  - a. The parts numbers and descriptions must match the current parts price list.
  - b. The list must be typed or computer generated.
  - c. The list must state the reason(s) for the return.
  - d. The list must reference the sales order(s) or invoice(s) under which the items were originally purchased.
  - e. The list must include the name and phone number of the person requesting the RMA.
3. A copy of the Return Material Authorization must accompany the return shipment.
4. Freight is at the sender's expense. All parts must be returned freight prepaid to Multiquip's designated receiving point.
5. Parts must be in new and resalable condition, in the original Multiquip package (if any), and with Multiquip part numbers clearly marked.
6. The following items are not returnable:
  - a. Obsolete parts. (If an item is in the price book and shows as being replaced by another item, it is obsolete.)
  - b. Any parts with a limited shelf life (such as gaskets, seals, "O" rings, and other rubber parts) that were purchased more than six months prior to the return date.
  - c. Any line item with an extended dealer net price of less than \$5.00.
  - d. Special order items.
  - e. Electrical components.
  - f. Paint, chemicals, and lubricants.
  - g. Decals and paper products.
  - h. Items purchased in kits.
7. The sender will be notified of any material received that is not acceptable.
8. Such material will be held for five working days from notification, pending instructions. If a reply is not received within five days, the material will be returned to the sender at his expense.
9. Credit on returned parts will be issued at dealer net price at time of the original purchase, less a 15% restocking charge.
10. In cases where an item is accepted, for which the original purchase document can not be determined, the price will be based on the list price that was effective twelve months prior to the RMA date.
11. Credit issued will be applied to future purchases only.

**PRICING AND REBATES**

Prices are subject to change without prior notice. Price changes are effective on a specific date and all orders received on or after that date will be billed at the revised price. Rebates for price declines and added charges for price increases will not be made for stock on hand at the time of any price change.

Multiquip reserves the right to quote and sell direct to Government agencies, and to Original Equipment Manufacturer accounts who use our products as integral parts of their own products.

**SPECIAL EXPEDITING SERVICE**

A \$35.00 surcharge will be added to the invoice for special handling including bus shipments, insured parcel post or in cases where Multiquip must personally deliver the parts to the carrier.

**LIMITATIONS OF SELLER'S LIABILITY**

Multiquip shall not be liable hereunder for damages in excess of the purchase price of the item with respect to which damages are claimed, and in no event shall Multiquip be liable for loss of profit or good will or for any other special, consequential or incidental damages.

**LIMITATION OF WARRANTIES**

No warranties, express or implied, are made in connection with the sale of parts or trade accessories nor as to any engine not manufactured by Multiquip. Such warranties made in connection with the sale of new, complete units are made exclusively by a statement of warranty packaged with such units, and Multiquip neither assumes nor authorizes any person to assume for it any other obligation or liability whatever in connection with the sale of its products. Apart from such written statement of warranty, there are no warranties, express, implied or statutory, which extend beyond the description of the products on the face hereof.



# OPERATION AND PARTS MANUAL

## HERE'S HOW TO GET HELP

PLEASE HAVE THE MODEL AND SERIAL  
NUMBER *ON-HAND* WHEN CALLING

### UNITED STATES

#### ***Multiquip Corporate Office***

18910 Wilmington Ave. Tel. (800) 421-1244  
Carson, CA 90746 Fax (800) 537-3927  
Contact: mq@multiquip.com

#### ***Mayco Parts***

800-306-2926 Fax: 800-672-7877  
310-537-3700 Fax: 310-637-3284

#### ***Service Department***

800-421-1244 Fax: 310-537-4259  
310-537-3700

#### ***MQ Parts Department***

800-427-1244 Fax: 800-672-7877  
310-537-3700 Fax: 310-637-3284

#### ***Warranty Department***

800-421-1244, Ext. 279 Fax: 310-537-1173  
310-537-3700, Ext. 279

#### ***Technical Assistance***

800-478-1244 Fax: 310-631-5032

### MEXICO

#### ***MQ Cipsa***

Carr. Fed. Mexico-Puebla KM 126.5 Tel: (52) 222-225-9900  
Momoxpan, Cholula, Puebla 72760 Mexico Fax: (52) 222-285-0420  
Contact: pmastretta@cipsa.com.mx

### CANADA

#### ***Multiquip***

4110 Industriel Boul. Tel: (450) 625-2244  
Laval, Quebec, Canada H7L 6V3 Fax: (450) 625-8664  
Contact: jmartin@multiquip.com

### UNITED KINGDOM

#### ***Multiquip (UK) Limited Head Office***

Hanover Mill, Fitzroy Street, Tel: 0161 339 2223  
Ashton-under-Lyne, Fax: 0161 339 3226  
Lancashire OL7 0TL  
Contact: sales@multiquip.co.uk

### BRAZIL

#### ***Multiquip***

Av. Evandro Lins e Silva, 840 - grupo 505 Tel: 011-55-21-3433-9055  
Barra de Tijuca - Rio de Janeiro Fax: 011-55-21-3433-9055  
Contact: cnavarro@multiquip.com.br, srentes@multiquip.com.br

© COPYRIGHT 2007, MULTQUIP INC.

Multiquip Inc and the MQ logo are registered trademarks of Multiquip Inc. and may not be used, reproduced, or altered without written permission. All other trademarks are the property of their respective owners and used with permission.

This manual MUST accompany the equipment at all times. This manual is considered a permanent part of the equipment and should remain with the unit if resold.

The information and specifications included in this publication were in effect at the time of approval for printing. Illustrations are based on the *MQ41TDH Diesel Powered Trash Pump*. Illustrations, descriptions, references and technical data contained in this manual are for guidance only and may not be considered as binding. Multiquip Inc. reserves the right to discontinue or change specifications, design or the information published in this publication at any time without notice and without incurring any obligations.

Your Local Dealer is:

