

PARTS AND OPERATION MANUAL

MULTIQUIP **Model GA-2.3R2** **A.C. GENERATOR**

© COPYRIGHT 2001, MULTIQUIP INC.

Revision #2 (03/05/01)



MULTIQUIP INC.

18910 WILMINGTON AVE.
CARSON, CALIFORNIA 90746
310-537-3700
800-421-1244
FAX: 310-537-3927

E-mail: mq@multiquip.com • **www:** multiquip.com

Atlanta • Boise • Dallas • Houston • Newark
Montreal, Canada • Manchester, UK
Rio De Janeiro, Brazil • Guadalajara, Mexico

PARTS DEPARTMENT:

800-427-1244
FAX: 800-672-7877

SERVICE DEPARTMENT/TECHNICAL ASSISTANCE:

800-478-1244
FAX: 310-631-5032



WARNING



CALIFORNIA — Proposition 65 Warning

Engine exhaust and some of its constituents are known to the State of California to cause cancer, birth defects and other reproductive harm.

HERE'S HOW TO GET HELP

*PLEASE HAVE THE MODEL AND SERIAL NUMBER
ON-HAND WHEN CALLING*

PARTS DEPARTMENT

800-427-1244 or 310-537-3700

FAX: 800-672-7877 or 310-637-3284

SERVICE DEPARTMENT/TECHNICAL ASSISTANCE

800-478-1244 or 310-537-3700

FAX: 310- 537-4259

WARRANTY DEPARTMENT

888-661-4279, or 310-661-4279

FAX: 310- 537-1173

MAIN

800-421-1244 or 310-537-3700

FAX: 310-537-3927

Here's How To Get Help 3
 Table Of Contents 4
 Parts Ordering Procedures 5
 Rules For Safe Operation 6
 Operation and Safety Decals 7
 Specifications 8
 General Information 9

Multiquip GA-2.3R2 — AC Generator

Controls and Indicators 10
 Installation 11
 Pre-Setup 12-13
 Instrumentation 14
 Load Application 15
 Operating Instructions 16
 Maintenance 17
 Preparation For Long Term Storage 18
 Wiring Diagram 19
 Troubleshooting (Engine) 20-21
 Troubleshooting (Generator) 22-23
 Explanation Of Codes In Remarks Column 24
 Suggested Spare Parts 25
 Generator Assembly 26-27
 Control Box Assembly 28-29
 Pipe Frame Assembly 30-31
 Name Plate And Decals 32-33

Robin EH-17 Engine

Crankcase Assembly 34-35
 Crankshaft & Piston Assembly 36-37
 Intake & Exhaust Assembly 38-39
 Governor Assembly 40-41
 Cooling & Starting Assembly 42-43
 Fuel & Lubricant Assembly 44-45
 Electric Coil Assembly And Spark Plug 46-47
 Oil Sensor Assembly 48-49
 Fuel Strainer 50-51

Terms and Conditions Of Sale — Parts 52

NOTE

*Specification and part number
are subject to change without
notice.*

- Dealer account number
- Dealer name and address
- Shipping address (if different than billing address)
- Return fax number
- Applicable model number
- Quantity, part number and description of each part
- Specify preferred method of shipment:
 - UPS Ground
 - UPS Second Day or Third Day*
 - UPS Next Day*
 - Federal Express Priority One (please provide us with your Federal Express account number)*
 - Airborne Express*
 - Truck or parcel post

**Normally shipped the same day the order is received, if prior to 2PM west coast time.*

Earn Extra Discounts when you order by FAX!

All parts orders which include complete part numbers and are received by fax qualify for the following extra discounts:

<u>Number of line items ordered</u>	<u>Additional Discount</u>
1-9 items	3%
10+ items**	5%

**Extra Fax Discount
for Domestic USA
Dealers Only**

**Up to 5%
extra savings!**

**UPS
Special**
For faxed orders only

Get special freight allowances when you order 10 or more line items via FAX! **

- UPS Ground Service at no charge for freight
- PS Third Day Service at one-half of actual freight cost

No other allowances on freight shipped by any other carrier.

**Common nuts, bolts and washers (all items under \$1.00 list price) do not count towards the 10+ line items.

DISCOUNTS ARE SUBJECT TO CHANGE

Fax order discount and UPS special programs revised June 1, 1995

Now! Direct TOLL-FREE access to our Parts Department!

Toll-free nationwide:

800-421-1244

Toll-free FAX:

800/6-PARTS-7 • 800-672-7877

CAUTION:



Failure to follow instructions in this manual may lead to serious injury or even death! This equipment is to be operated by trained and qualified personnel only! This equipment is for industrial use only.

The following safety guidelines should always be used when operating the GA-2.3R2 Generator:

GENERAL SAFETY

- **DO NOT** operate or service this equipment before reading this entire manual.
- This equipment should not be operated by persons under 18 years of age.
- **NEVER** operate this equipment without proper protective clothing, shatterproof glasses, steel-toed boots and other protective devices required by the job.
- This generator is a source of providing **LETHAL** high voltages. Never permit unqualified personnel—especially children to operate the generator.
- Always refuel in a well-ventilated area, away from sparks and open flames.
- Always use extreme caution when working with **flammable** liquids. When refueling, **stop the engine** and allow it to cool. **DO NOT** smoke around or near the machine. Fire or explosion could result from flames or sparks, or if fuel is spilled on a hot engine.
- This generator is equipped with a **ground terminal** for your protection. Always complete the grounding path from the generator to an external grounding source.
- **NEVER** operate this generator, or handle any electrical equipment while standing in **water, while bare foot, while hands are wet, or in the rain**. *Dangerous electrical shock could occur causing severe bodily harm or even death.*
- Keep electrical cords in good condition. Worn, bare or frayed wiring can cause electrical shock, thus causing *bodily harm or even death*.
- This generator requires an adequate free flow of cooling air. Never operate the generator in any enclosed or narrow area where free flow of the air is restricted. If the air flow is restricted it will cause serious damage to the generator and may cause injury to people.
- **NEVER** touch the hot exhaust manifold, muffler or cylinder. Allow these parts to cool before servicing generator.

- Provide adequate ventilation when operating the generator. **DO NOT** operate the generator in any enclosed or narrow space. The generator's gasoline engine gives off **DEADLY** monoxide gas.
- **NEVER** operate the generator in an explosive atmosphere or near combustible materials. An explosion or fire could result causing severe *bodily harm or even death*.
- Always make sure that the generator is secure on level ground so that it cannot slide or shift around, endangering workers. Also keep the immediate area free of bystanders.

CAUTION:

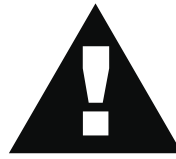

- **High Temperatures** – Allow the machine and engine to cool before adding fuel or performing service and maintenance functions. Contact with *hot* components can cause serious burns.

CAUTION:



Emergencies

- Always know the location of the nearest **fire extinguisher** and **first aid kit**. Know the location of the nearest telephone. Also know the phone numbers of the nearest **ambulance, doctor** and **fire department**. This information will be invaluable in the case of an emergency.

Maintenance Safety

- **NEVER** lubricate components or attempt service on a running machine.
- Always allow the machine a proper amount of time to cool before servicing.
- Keep the machinery in proper running condition.
- Fix damage to the machine immediately and always replace broken parts.
- Dispose of hazardous waste properly. Examples of potentially hazardous waste are used motor oil, fuel and fuel filters.
- **DO NOT** use food or plastic containers to dispose of hazardous waste.
- **DO NOT** pour waste, oil or fuel directly onto the ground, down a drain or into any water source.

OPERATION AND SAFETY DECALS

Machine Safety Decals

The GA-2.3R2 portable generator is equipped with a number of safety decals. These decals are provided for operator safety and maintenance information. The illustration below shows these decals as they appear on the machine. Should any of these decals become unreadable, replacements can be obtained from your dealer.



P/N 7930615603



P/N 7900636004

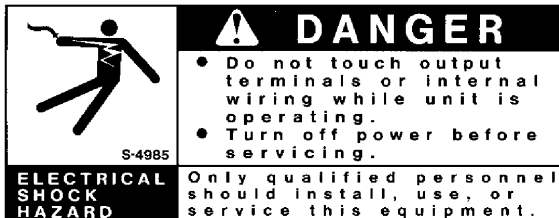

P/N 8700611904

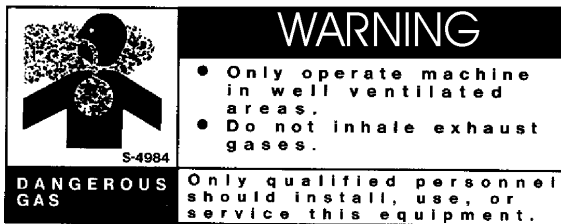

P/N 8700611804

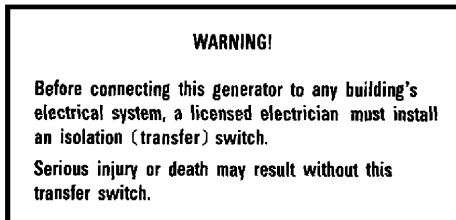

P/N 0820610404



P/N 0800628504

OPERATING INSTRUCTIONS

1. Before starting check the oil and fuel level.
2. Switch the circuit breaker to the "OFF" position.
3. Open the fuel valve.
4. Pull the choke knob.
5. Turn the operation switch to the "RUN" position and push.
6. Pull the recoil starter.
7. After the engine starts, gradually push in the choke valve.
8. Run the generator for 3-5 minutes without load.
9. Check for any abnormal noise or smell.
10. Switch the circuit breaker to the "ON" position.
11. When stopping, remove the load and allow it to continue to run for 2-3 minutes before stopping engine.
2. Turns the operation switch to the "STOP" position.
3. After the engine completely stops, close the fuel valve.

S-4607

P/N 7900638204

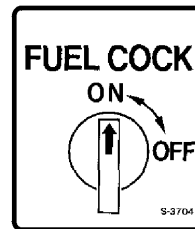

P/N 1980680004

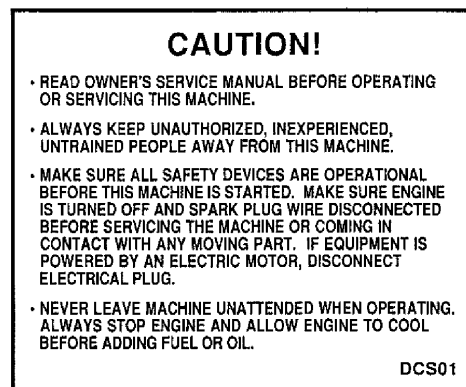

DCS01

P/N 0820610804

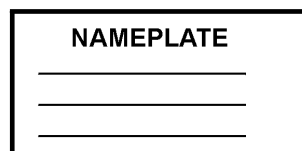

CONTACT MULTIQUIP SERVICE DEPT.

Table 1. Specifications

MODEL		GA-2.3R2
	Type	2-pole, Brushless Type Revolving Field
Generator	Max. Output	2300 Watts
	Rated Output (continuous)	2000 Watts
	Rated Voltage	120 Volts
	Phase	Single Phase (2-wire)
	Frequency	60 Hz
	Rated Speed	3600 RPM
	Power Factor	100%
Engine	Model	Robin EH-17
	Type	Air-cooled 4 cycle, vertical OVH type, gasoline engine
	Number of cylinders	1
	Bore X Stroke	1-2.64 in x 1.93 in
	Displacement	10.50 Cu. in
	Max Output	5 H.P./3600 R.P.M.
	Fuel Tank Capacity	Approx. 3-3/16 U.S. Gallons
	Fuel	Unleaded Automobile Gasoline
	Lube Oil Capacity	1-3/8 pints
	Speed Control Method	Centrifugal Fly-weight Type
	Starting Method	Recoil Start
Dimension (LXWXH)		530X 380 X 515mm
Dry Net Weight		99 lbs (45kg)

Effects of Altitude and Heat

The maximum output of the engine listed above is applicable to supplying electrical power for continuous service at ambient conditions in accordance with SAE Test cord J607. The above ambient conditions are at standard sea level, with a barometric reading of 29.92 inches and a temperature of 60 degrees fahrenheit.

Generally, the engine output power will decrease 3 1/2% for each 1000 feet of altitude above sea level, and 1% for each 10° F fahrenheit above the standard temperature of 60° F

GA-2.3R2 FAMILIARIZATION

Generator

The Multiquip Model GA-2.3R2 generator has been designed as a portable lightweight power source for 60 Hz (single-phase) vibrators, lighting facilities, power tools, sersmersible pumps and other industrial and construction machinery.

This generator employs the highly reliable **ROBIN** engine. The alternator, a brushless revolving-field type, single phase is permanently aligned to the engine through rigid coupling.

The entire generator is mounted on rubber vibration isolators that have a steel base backplate which is attached to the protective steel pipe carrying frame. The protective carrying frame is made of steel tubing and fully wraps around the generator to protect against damage.

This portable generator is supplied with a electrical **control box**. To reduce vibration caused by the engine, the control box is also placed on rubber isolators.

Control Box

The control box has the following: (output is 60 Hz, single phase)

- One 120V output receptacle (GFCI protected).
- One main 17 amp circuit breaker.
- AC Voltmeter
- Ground Terminal

Excitation System

All GA-series generators use a magnet attached to a flywheel to produce AC voltage from a lamp coil beneath the flywheel. As the magnetic passes the coil it produces approximately 19-22 AC volts.

This voltage (19-22 VAC) is then sent to the control box that contains three rectifying diodes:

- Excitation (diode 1)
- Battery (diode 2)
- Slow Down (diode 3)

The AC voltage will pass through the excitation diode that converts the voltage to DC power.

This DC power is then sent to the excitation windings housed within the main windings commonly called the "stator".

This voltage is then transferred into the rotor through induction. The rotor contains two diodes within it which rectify the DC voltage and send it out through the main windings, as AC voltage.

Engine

The four-cycle air-cooled ROBIN gasoline engine is designed to meet every performance requirement of this generator. Reference Table 1, page 8 for engine specifications

In keeping with Multiquip's policy of constantly improving its products, the specifications quoted herein are subject to change without prior notice.

Figure 1 (page 10) shows the basic controls and indicators for the GA-2.3R2 generator.

GA-2.3R2 — CONTROLS AND INDICATORS

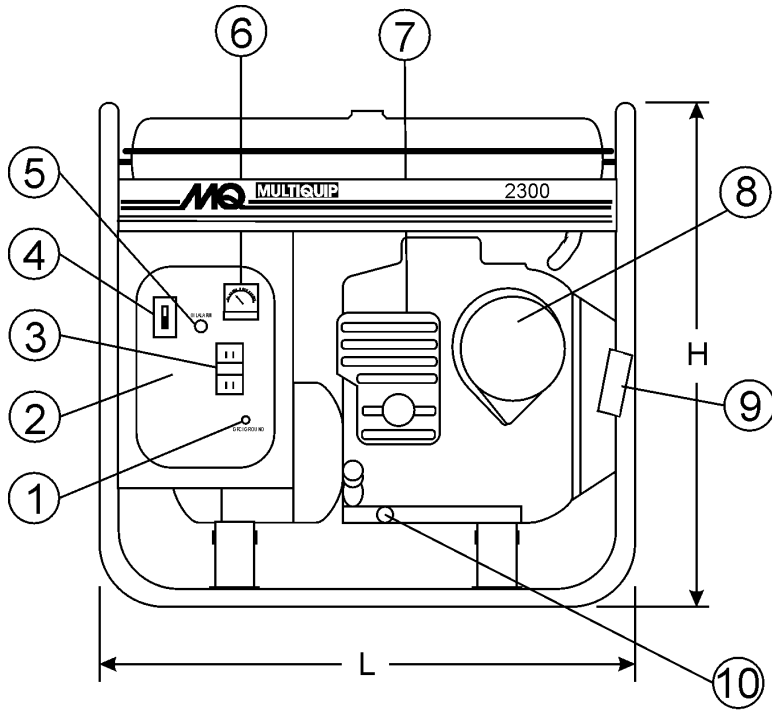

NO.	PARTS NAME
1	GROUND TERMINAL
2	CONTROL BOX
3	RECEPTACLE (120V, GFCI)
4	CIRCUIT BREAKER
5	OIL ALARM LAMP
6	AC VOLTMETER
7	MUFFLER
8	AIR CLEANER
9	STARTING KNOB
10	OIL DRAIN PLUG
11	SPARK PLUG
12	FUEL TANK

L	W	H
15.0 IN. 380 MM	20.9 IN. 530 MM	20.3 IN. 515 MM

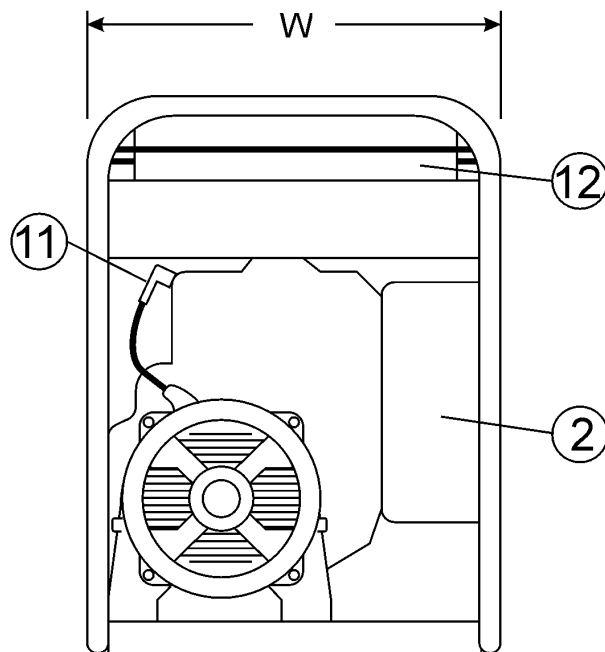

Figure 1. Controls and Indicators

Outdoor Installation

Install the generator in a location where it will not be exposed to rain or sunshine. Make sure that the generator is on secure level ground so that it cannot slide or shift around. Also install the generator in a manner so that the exhaust will not be discharged in the direction of nearby homes.

The installation site must be relatively free from moisture and dust. All electrical equipment should be protected from excessive moisture. Failure to do so will result in deterioration of the insulation and will result in short circuits and grounding.

Foreign materials such as dust, sand, lint and abrasive materials have a tendency to cause excessive wear, not only to the engine parts, but also to the alternator parts.

CAUTION :



Pay close attention to ventilation when operating the generator inside tunnels and caves. The engine exhaust contains noxious elements.

Indoor Installation

Exhaust gases from gasoline engines are extremely poisonous. Whenever an engine is installed indoors the exhaust fumes must be vented to the outside. The engine should be installed at least two feet from any outside wall. Using an exhaust pipe which is too long or too small can cause excessive back pressure which will cause the engine to heat excessively and possibly burn the valves.

Eliminate the danger of deadly carbon monoxide gas. Remember that exhaust fumes from any gasoline engine are very poisonous if discharged in a closed room, but harmless if allowed to mix with the outside air. If the generator is installed indoors, you must make provisions for venting the engine exhaust to the outside of the building.

CAUTION :



An electric shock is apt to happen when vibrators are used. Pay close attention to handling when operating vibrators and always use rubber boots and gloves to insulate the body from a short circuit.

General Inspection Prior to Operation

This generator has been thoroughly inspected and accepted prior to shipment from the factory. However, be sure to check for damaged parts or components, or loose nuts and bolts, which could have occurred in transit.

Ground

The nut and ground terminal on the generator should always be used to connect the generator to a suitable ground. The ground path should be of #8 size wire.

Connect the terminal of the ground wire between the lock washer and the nut and tighten the nut fully. Connect the other end of this wire to a suitable ground.

Circuit Breaker

A 2-pole, 17 amp circuit breaker is provided on the control box to protect the generator from an overload. Make sure to switch the circuit breakers to the "OFF" position prior to starting the engine.

Extension Cable

When electric power is to be provided to various tools or loads at some distance from the generator, extension cords are normally used. Cables should be sized to allow for distance in length and amperage so that the voltage drop between the generator and point of use (load) is held to a minimum. Use the cable selection chart (Table 2) as a guide for selecting proper cable size.

Table 2. Cable Selection (60 Hz, single phase operation)

Current in Amperes	Load In Watts	Maximum Allowable Cable Length			
	At 120 Volts	#10 Wire	#12 Wire	#14 Wire	#16 Wire
2.5	300	1000 ft.	600 ft.	375 ft.	250 ft.
5	600	500 ft.	300 ft.	200 ft.	125 ft.
7.5	900	350 ft.	200 ft.	125 ft.	100 ft.
10	1200	250 ft.	150 ft.	100 ft.	
15	1800	150 ft.	100 ft.	65 ft.	
20	2400	125 ft.	75 ft.	50 ft.	

CAUTION: Equipment damage can result from low voltage.

Lubrication Oil

Fill the engine crankcase with lubricating oil through the filler hole, but do not overfill. Make sure the generator is level. With the dipstick inserted all the way, but without being screw into the filler hole, verify that the oil level is maintained between the two notches on the dipstick.

The oil listed in Table 3 is recommended to ensure better engine performance. Use class SC or higher grade motor oil.

NOTE

This ROBIN engine is equipped with a low oil shutdown capability. A built in sensor will automatically turn off the engine should the oil level fall below a safe operating condition. Make sure the generator is placed on level ground. Placing the generator on level ground will ensure that the low oil sensor will function properly.

Fuel

Close the fuel cock before filling the tank. Fill the fuel tank with clean and fresh unleaded gasoline. Do not fill the tank beyond capacity.

Pay attention to the fuel tank capacity when replenishing fuel. Refer to the fuel tank capacity listed on page 8 Specification Table1.

The fuel tank cap must be closed tightly after filling.

Handle fuel in a safety container. If the container does not have a spout, use a funnel.

CAUTION :



Never fill the fuel tank while the engine is running or in the dark. Gasoline spillage on a hot engine can cause a fire or explosion. If gasoline spillage occurs, wipe up the spilled gasoline completely to prevent fire hazards.

Table 3. Recommended Motor Oil

Temperature Range	Type Oil
104° F ~ 23° F (40° C ~ -5°C)	SAE 30
23° F ~ 5° F (-5° C ~ -15°C)	SAE 20 or sae 10W-30
Below 5° C (-15°)	SAE 10W or SAE 10W-30

CAUTION :



When using a combination of dual receptacles, total load should not exceed the rated capacity of the generating set.

Power Outlets

The generator has the following 120 volt 60 Hz (single-phase) receptacle.

- Single Phase
 - One Duplex NEMA (GFCI) 5-20R (120V, 20 Amp)

Main Circuit Breaker (2-Pole 60 Hz)

This 2-pole, 17 amp breaker protects the generator from short circuiting or overloading from the 120V 60 Hz single phase load.

Fuel Gauge

The fuel gauge is located on the fuel tank and allows easy monitoring of the fuel level.

AC Voltmeter

This voltmeter indicates (with a mark) the rated 60 Hz, single phase output voltage.

Single Phase Load

Always be sure to check the nameplate on the generator and equipment to insure the wattage, amperage and frequency requirements are satisfactorily supplied by the generator for operating the equipment.

Generally, the wattage listed on the nameplate of the equipment is its rated output. Equipment may require 130—150% more wattage than the rating on the nameplate, as the wattage is influenced by the efficiency, power factor and starting system of the equipment.

NOTE

If wattage is not given on the equipment's name plate, approximate wattage may be determined by multiplying nameplate voltage by the nameplate amperage.

WATTS = VOLTAGE x AMPERAGE

To determine the running wattage for your load, multiply the running wattage as indicated by steps 1, 2, and 3 below:

1. INCANDESCENT LOADS

Lights, heaters and similar appliances.

Total the running wattage and multiply by 1.

Example:

29 light bulbs @ 100W each = 2.9 KW

use a 3 KW generator.

2. SMALL MOTORS

Drills and other small power tools.

Total the running wattage and multiply by 2.

Example:

A 1 inch drill runs at 1 KW

use a 2 KW generator.

3. LARGE MOTORS

Submersible pumps, table saws etc.

Total the running wattage and multiply by 3.

Example:

A conveyor belt runs at 8 KW

use a 24 KW generator.

CAUTION:



Motors and motor-driven equipment draw much greater current for starting than during operation.

An inadequate size connecting cable which cannot carry the required load can cause a voltage drop which can burn out the appliance or tool and overheat the cable.

The idle control is operated at minimum load capacity of 100W. If the load capacity is less than 100W, throw the idle control switch to the OFF position.

Before Starting

1. Be sure to disconnect the electrical load and switch the main circuit breaker to the "OFF" position prior to starting the engine.
2. Never start the engine with the main circuit breaker "ON".
3. Check the lubricating oil level prior to starting the engine. Make sure the generator is level. The oil level must be maintained between two notches on the dipstick.
4. When there is not enough lubricating oil, fill the crankcase with high grade motor oil. Use a high quality detergent oil classified SC, SD or SE. (See Table 3 on page 13)

CAUTION:



- NEVER start the engine when the oil level is below the lower mark on the dipstick.
- Check the fuel level on the fuel gauge. When fuel is low, fill the fuel tank with clean fresh unleaded automotive gasoline.
- If gasoline spillage occurs, completely wipe up the spilled gasoline.

Starting

1. Open the fuel cock located below the fuel tank. The fuel starts to flow when the fuel cock is turned downward.
2. Place the idle control switch in the "ON" (up) position.
3. Close the choke. Adjust the opening of the choke valve according to operating conditions. When the engine is warm or the air temperature is high, close the choke valve halfway or open it all the way.
4. Confirm that the main circuit breaker on the generator control box is "OFF".
5. Set the operation switch to the "ON" position and grasp the starting knob and slowly pull it out. The resistance becomes hardest at a certain position, corresponding to the compression point. Rewind the rope a little from that point and pull out sharply.
6. If the engine fails to start, repeat the procedure.

CAUTION:



- DO NOT pull the starter rope all the way to the end.
- DO NOT release the starter knob after pulling. Allow it to rewind as soon as

Warm up

1. When the engine starts, open the choke slowly.
2. Run the engine at low speed for 3 minutes without load until the engine warms up.
3. Turn the idle control switch to the "OFF" (down) position and check the voltage by referring to the voltmeter on the control box.

CAUTION:



DO NOT change the engine speed control lever which has been set at the factory prior to shipping.

1. Check the generator for abnormal noise and smells. Then connect the load to the receptacles of the generator.
2. Switch the main circuit breaker to the "ON" position and turn the idle control switch to the "ON" (down) position for normal (load) engine operation.

Operation

Check the voltage by referring to the voltmeter on the control box. When the voltmeter indicates 120 volts, 120 volts from the 120V receptacle can be obtained. Refer to Figure 1, Controls and Indicators, item 1 on page 10.

Stopping the Engine

CAUTION:



NEVER stop the engine suddenly while running at high speeds.

1. Remove the load from the generator. Place the circuit breaker in the "OFF" position. Refer to Figure 1, item 9 on page 10. Run the engine (no-load) with the idle control switch set to the ON position for three to five minutes, then stop the engine.
2. Turn the START/STOP switch to the "STOP" position.
3. Close the fuel cock.

General Inspection

At least daily or prior to each use, the generating set should be cleaned and inspected for deficiencies. Check for loose, missing or damaged nuts, bolts or other fasteners. Also check for fuel or oil leaks.

Engine Side (Refer to the Engine Instruction Manual)**Check Oil Level**

Check the crankcase oil level prior to each use, or when the fuel tank is filled. Make sure the generating set is level. The oil level must be between the two notches on the dipstick.

Changing Oil

Change oil after the first 20 hours of operation. Drain and refill the engine crankcase every 50 operating hours or once a week thereafter. Drain crankcase oil into a suitable container while engine is still warm. Replace the drain plug tightly. Add oil through the filler hole.

Air Cleaner

Every 50 hours: Remove air cleaner element (std. or heavy duty types), and wash in kerosene or liquid detergent and hot water. Wrap foam element in a cloth and squeeze dry. Wipe heavy duty paper element dry with toweling. Saturate element with kerosene; squeeze excess from foam element. Wipe excess from heavy duty paper element.

Service Daily

If engine is operating in very dusty and dry grass conditions. A clogged air cleaner will result in high fuel consumption, loss of power and excessive carbon buildup in the combustion chamber.

Cleaning the Fuel Strainer

Clean the fuel strainer if it contains dust or water. Remove dust or water in the strainer cap and wash it in gasoline. Securely fasten the fuel strainer cap so that fuel will not leak. Check the fuel strainer every 200 hours of operation or once a month.

Spark Plug

Remove carbon build-up on the spark plug (Figure 2) with a wire brush. Set the spark plug gap to 0.6—0.7mm (0.024-0.028 inch). Tighten with a spark plug socket wrench. Clean the spark plug every 50 operating hours or once a week.

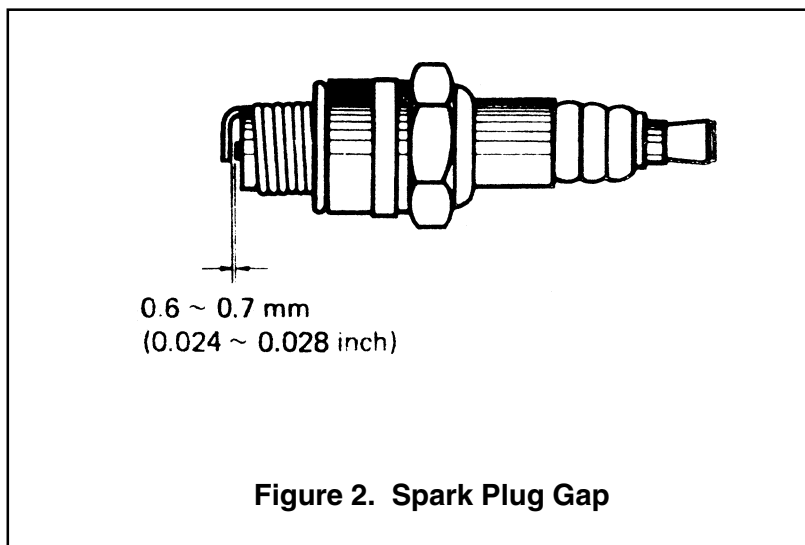

GA-2.3R2 — PREPARATION FOR LONG -TERM STORAGE

Generator Storage

For storage of the generating set for over 30 days, the following is required:

- Drain the fuel tank completely.
- Run the engine until the gasoline in the carburetor is completely consumed.
- Completely drain the oil from the crankcase and refill with fresh oil.
- Remove the spark plug, pour 2 or 3 cc of SAE 30 oil into the cylinder and crank slowly to distribute the oil.
- Slowly rotate the engine a few times with the starter Rope and install a new plug.
- Pull out the starter rope slowly and stop at the compression point.
- Clean all external parts of the generating set with a cloth.
- Cover the generating set and store in a clean, dry place.

GENERATOR

SYMBOL	PART NAME
Ar	Armature Winding
Fg	Field Winding
EXW1~2	Excitation Winding
CON	Receptacle for 120V
V	AC Voltmeter
CB	Circuit Breaker
Re1	Rectifier
LED	Oil Alarm Lamp

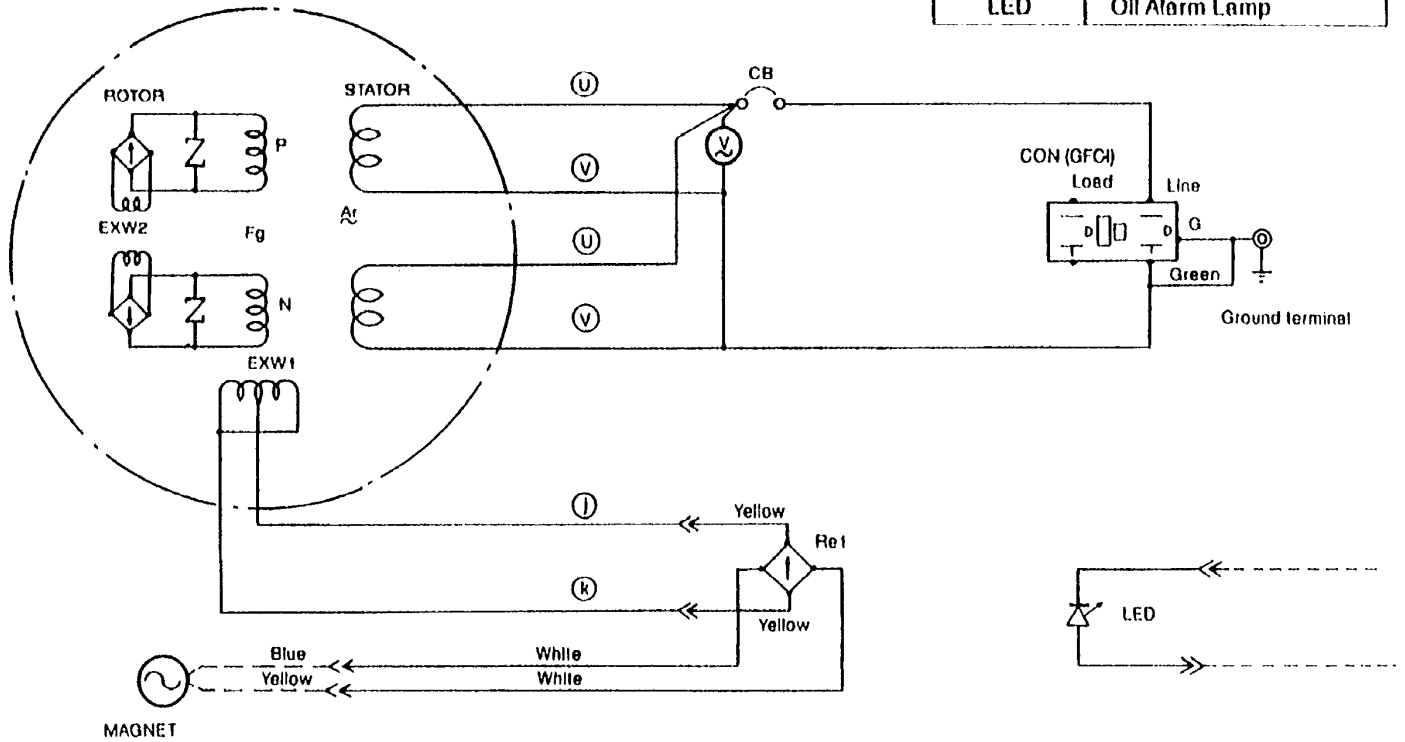

ENGINE

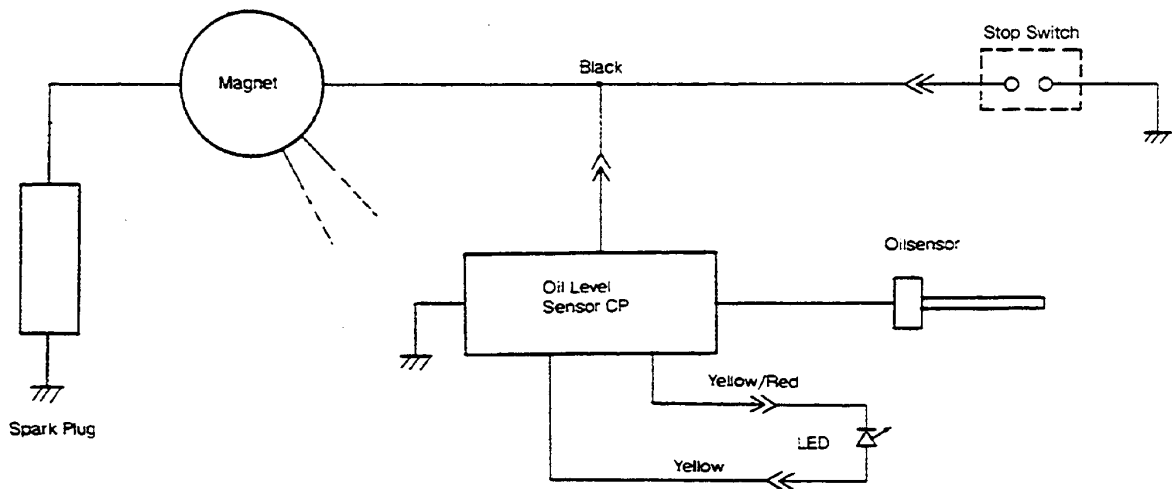

GA-2.3R2 — TROUBLESHOOTING (ENGINE)

Practically all breakdowns can be prevented by proper handling and maintenance inspections, but in the event of a breakdown, please take a remedial action following the

diagnosis based on the Engine Troubleshooting (Table 4) information shown below and on the preceding page. If the problem cannot be remedied, please leave the unit just as it is and consult our company's business office or service plant.

TABLE 4. ENGINE TROUBLESHOOTING

SYMPTOM	POSSIBLE PROBLEM	SOLUTION
Poor starting	Inspect carburetor to see if fuel is reaching it?	Check fuel line
	No Fuel?	Add Fuel
	Water in fuel tank?	Flush or replace fuel tank.
	Fuel filter clogged?	Replace fuel filter
	Stuck carburetor?	Check float mechanism.
	Spark plug is red?	Spark plug is fouled. Check transistor ignition unit.
	Spark plug is blue-white?	Insufficient compression, injected air leaking. Carburetor jets are clogged (overflow).
	No spark present at tip of spark plug?	Transistor ignition unit broken, high voltage cord cracked or broken. Start/Stop switch broken. Replace spark plug if fouled.
	No oil?	Add oil as required.
	Oil pressure alarm lamp blinks upon starting?	Check Automatic shutdown circuit "oil sensor".
Insufficient power output "no compression"	Engine will not turn over?	Replace cylinder and piston and if necessary axel joint.
	Cylinder head connecting bolts loose?	Tighten cylinder head connecting bolts.
	Cylinder head gasket damaged?	Replace cylinder head gasket.
	Malfuction of valve seat?	Re-seat valves.
	Spark plug is loose?	Replace spark plug.
	Worn piston rings?	Replace piston rings.
Insufficient power output "compression"	Malfuction in air-cleaner system, air filter clogged?	Clean or replace air filter.
	Air leaking in from interface between carburetor and cylinder head?	Tighten bolts between carburetor and cylinder head. Replace cylinder head gasket.
	Malfuction in fuel system?	Clean or replace fuel filter. Clean or replace carburetor. Check carburetor float.

GA-2.3R2 — TROUBLESHOOTING (ENGINE)

TABLE 4. ENGINE TROUBLESHOOTING (CONTINUED)

SYMPTOM	POSSIBLE PROBLEM	SOLUTION
Insufficient power output "compression" and overheats	Malfunction in cooling fan?	Check or replace cooling fan.
	Air in-take filter clogged?	Clean or replace air in-take filter.
Burns to much fuel	Over accumulation of exhaust products?	Clean and check valves. Check muffler, replace if necessary.
	Wrong spark plug?	Replace spark plug with manufactures suggested type spark plug.
Exhaust color is continously "WHITE"	Lubricating oil is wrong viscosity?	Replace lubricating oil with correct viscosity.
	Worn rings?	Replace rings
Exhaust color is continously "BLACK"	Air cleanner clogged?	Clean or replace air cleaner.
	Choke valve has not been set to the correct position?	Adjust choke valve to the correct position.
	Carburetor defective, seal on carburetor broken?	Replace carburetor or seal.
	Poor carburetor adjustment "engine runs too rich?"	Adjust carburetor.

GA-2.3R2 — TROUBLESHOOTING (GENERATOR)

Practically all generator breakdowns can be prevented by proper handling and maintenance inspections, but in the event of a breakdown, please take a remedial action following the

diagnosis based on the Generator Troubleshooting (Table 5) information shown below and on the preceding page. If the problem cannot be remedied, please leave the unit just as it is and consult our company's business office or service plant.

TABLE 5. GENERATOR TROUBLESHOOTING

SYMPTOM	POSSIBLE PROBLEM	SOLUTION
Low voltage	Engine speed too low?	Raise engine speed to rated RPM.
Low voltage. Engine speed normal 2300 RPM (unloaded), 2000 RPM (idle)	AC voltmeter not working?	Replace AC voltmeter.
	Control box internal wiring malfunction?	Check control box wiring.
	Defective ignition coil?	Check red and green ignition wires. Replace ignition wires if necessary.
	Rotor winding malfunction?	Check or replace rotor.
	Stator winding malfunction?	Check or replace stator.
	Breaker malfunction?	Check or replace CB1.
Voltage output too high.	Engine speed too high?	Lower engine speed to rated RPM.
Voltage output too high. Engine speed normal 2300 RPM (unloaded), 2000 RPM (idle)	Control box internal wiring malfunction	Check control box wiring.
Circuit breaker will not turn on "NO LOAD"	Defective circuit breaker?	Replace circuit breaker.
Circuit breaker will turn on "LOADED" but trips immediately.	Overload?	Reduce load or replace breaker.
	Load circuit is shorted?	Check load circuit for short.
Does not accelerate from low to high "NO LOAD"	Stuck solenoid?	Check solenoid.
Does not accelerate from low to high "LOAD ACTIVE"	Control box internal wiring defective?	Check control box wiring

GA-2.3R2 — TROUBLESHOOTING (GENERATOR)

TABLE 5. GENERATOR TROUBLESHOOTING (CONTINUED)

SYMPTOM	POSSIBLE PROBLEM	SOLUTION
Does not decelerate no "VOLTAGE OUTPUT".	Defective rotor windings?	Check or replace rotor.
	Defective solenoid?	Check or replace solenoid.
	Defective idle control device?	Check or replace idle control device.
	Defective solenoid?	Check or replace idle control device.
Does not decelerate but has "VOLTAGE OUTPUT".	Control box wiring malfunction?	Check control box wiring, replace any defective components.
	Defective solenoid?	Check or replace solenoid.
	Idle control device malfunction?	Check or replace idle control device.

GA-2.3R2 — EXPLANATION OF CODE IN REMARKS COLUMN

How to read the marks and remarks used in this parts book.

Items Found In the “Remarks” Column

Serial Numbers-Where indicated, this indicates a serial number range (inclusive) where a particular part is used.

Model Number-Where indicated, this shows that the corresponding part is utilized only with this specific model number or model number variant.

Items Found In the “Items Number” Column

All parts with same symbol in the number column, *, #, +, %, or ■, belong to the same assembly or kit.

NOTE

If more than one of the same reference number is listed, the last one listed indicates newest (or latest) part available.

NOTE

The contents of this catalog are subject to change without notice.

GA-2.3R2 — SUGGESTED SPARE PARTS

GA-2.3R2 GENERATOR WITH ROBIN EH-17 ENGINE

1 to 5 Units

Qty.	P/N	Description
2	0601804883	CIRCUIT BREAKER
2	0601812597	RECEPTACLE
1	0601823204	RECTIFIER
2	0642008900	STRAINER, FUEL
3	0810107103	FILTER, FUEL
1	0810106004	CAP, FUEL TANK
5	2273261007	ELEMENT AIR CLEANER
1	0601800258	AC VOLTMETER
1	0601810695	OIL ALARM LAMP
5	0650140031	SPARK PLUG
1	0669900217	STOP SWITCH

5 to 10 Units

Qty.	P/N	Description
2	0601804883	CIRCUIT BREAKER
4	0601812597	RECEPTACLE
2	0601823204	RECTIFIER
4	0642008900	STRAINER, FUEL
3	0810107103	FILTER, FUEL
2	7925419604	SUSPENSION
2	0805084704	SUSPENSION
2	0810106004	CAP, FUEL TANK
10	2273261007	ELEMENT AIR CLEANER
2	0601800258	AC VOLTMETER
2	0601810695	OIL ALARM LAMP
10	0650140031	SPARK PLUG
2	0669900217	STOP SWITCH
1	2535020100	RECOIL STARTER ASSY.
1	2536240400	CARBURETOR ASSY.
1	KS31102211	OIL SENSOR

NOTE

Part numbers on this Suggested Spare Parts List may supercede/replace the P/N shown in the text pages of this book.

GA-2.3R2 — GENERATOR ASSY.

GENERATOR ASSY.

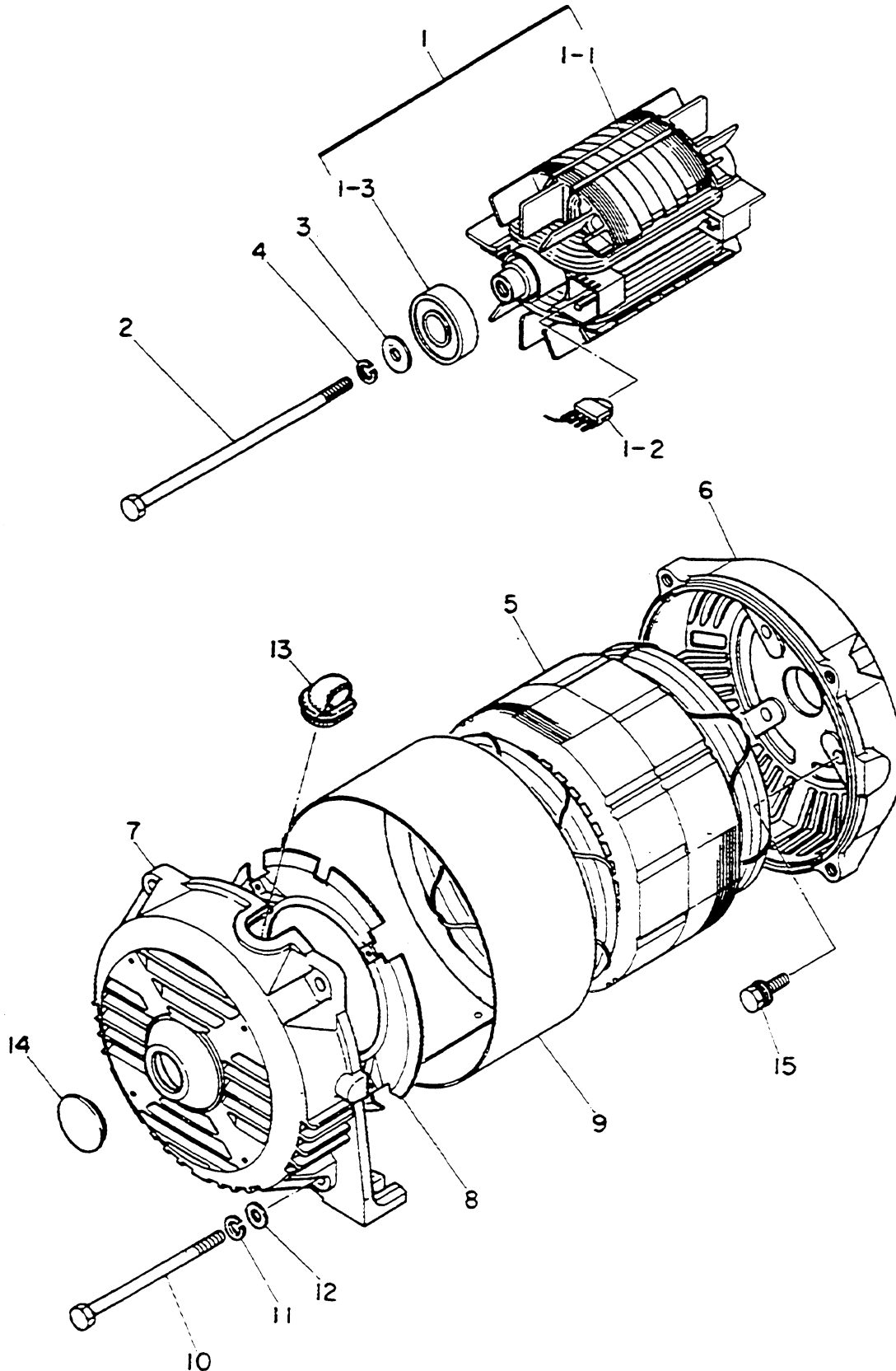

GA-2.3R2 — GENERATOR ASSY.

GENERATOR ASSY.

<u>NO</u>	<u>PART NO</u>	<u>PART NAME</u>	<u>QTY.</u>	<u>REMARKS</u>
1	7931000103	ROTOR ASSY	1	
1-1	7931080003	FIELD COIL	1	
1-2	0601823207	RECTIFIER	2	D3SB60 (S)
	0601822638	SURGE ABSORBER	2	TNR15G431K
1-3	0603000040	BEARING	1	6204 2RUNY5CM
2	7681017104	SET BOLT, ROTOR	1	
3	0801086004	SET WASHER, BEARING	1	
4	0040008000	SPRING WASHER	1	
5	7931341603	ARMATURE ASSY.	1	
6	7921315102	END BRACKET	1	
7	7681315022	END BRACKET	1	
8	7875021513	GUIDE PANEL, AIR	1	
9	7931334004	COVER	1	
10	7931316504	SET BOLT, STATOR	4	
11	0040006000	SPRING WASHER	4	
12	952404470	PLAIN WASHER	4	REPLACES 0041206000
13	7871329514	GROMMET	1	
14	0601851760	CAP	1	
15	011008020	HEX. HEAD BOLT	4	REPLACES 0017108020

GA-2.3R2 — CONTROL BOX ASSY.

CONTROL BOX ASSY.

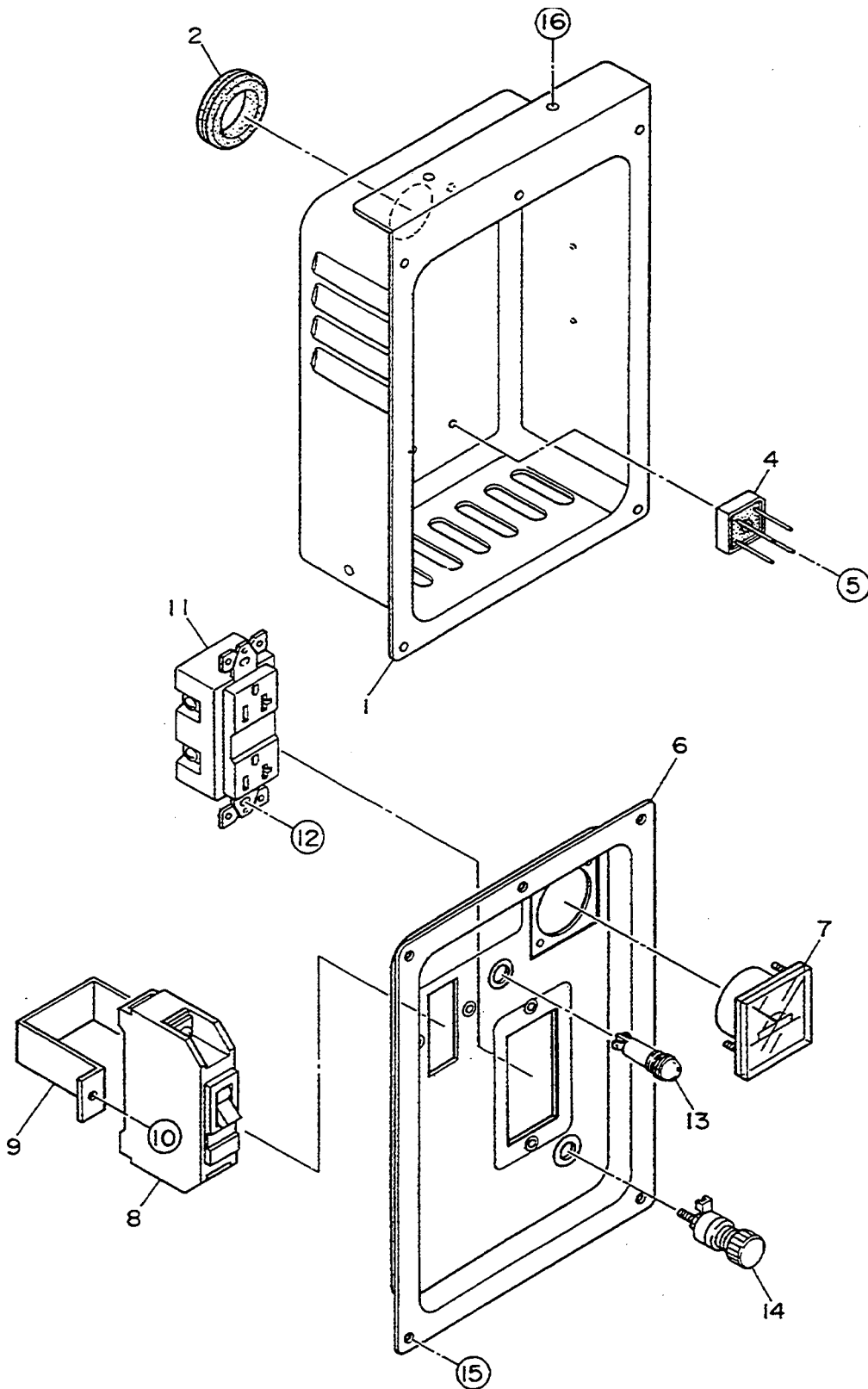

GA-2.3R2 — CONTROL BOX ASSY.

CONTROL BOX ASSY.

<u>NO</u>	<u>PART NO</u>	<u>PART NAME</u>	<u>QTY.</u>	<u>REMARKS</u>
1	7931800302	CONTROL BOX	1	
2	0601850245	GROMMET	1	
4	0601823204	RECTIFIER	1	S5 VB60
5	0027103020	MACHINE SCREW	1	
6	7931810503	CONTROL PANEL	1	
	7930602302	NAME PLATE	1	N-5245A
7	0601800258	AC VOLTMETER	1	0~120V
8	0601804883	CIRCUIT BREAKER	1	KM-51, 17A
9	3011816004	BRACKET, CIRCUIT BREAKER	1	
10	0021004010	MACHINE SCREW	2	
11	0601812597	RECEPTACLE	1	5-20R,GFCI
12	0021004010	MACHINE SCREW	2	
	0030004000	HEX NUT	2	REPLACES 0207004000
13	0601810695	OIL ALARM LAMP	1	06-106PR
14	0601815109	GROUND TERMINAL	1	T-381
15	55885	HEX. HEAD BOLT	5	REPLACES 0017105010
16	0017106016	HEX. HEAD BOLT	3	

GA-2.3R2 — PIPE FRAME ASSY.

PIPE FRAME ASSY.

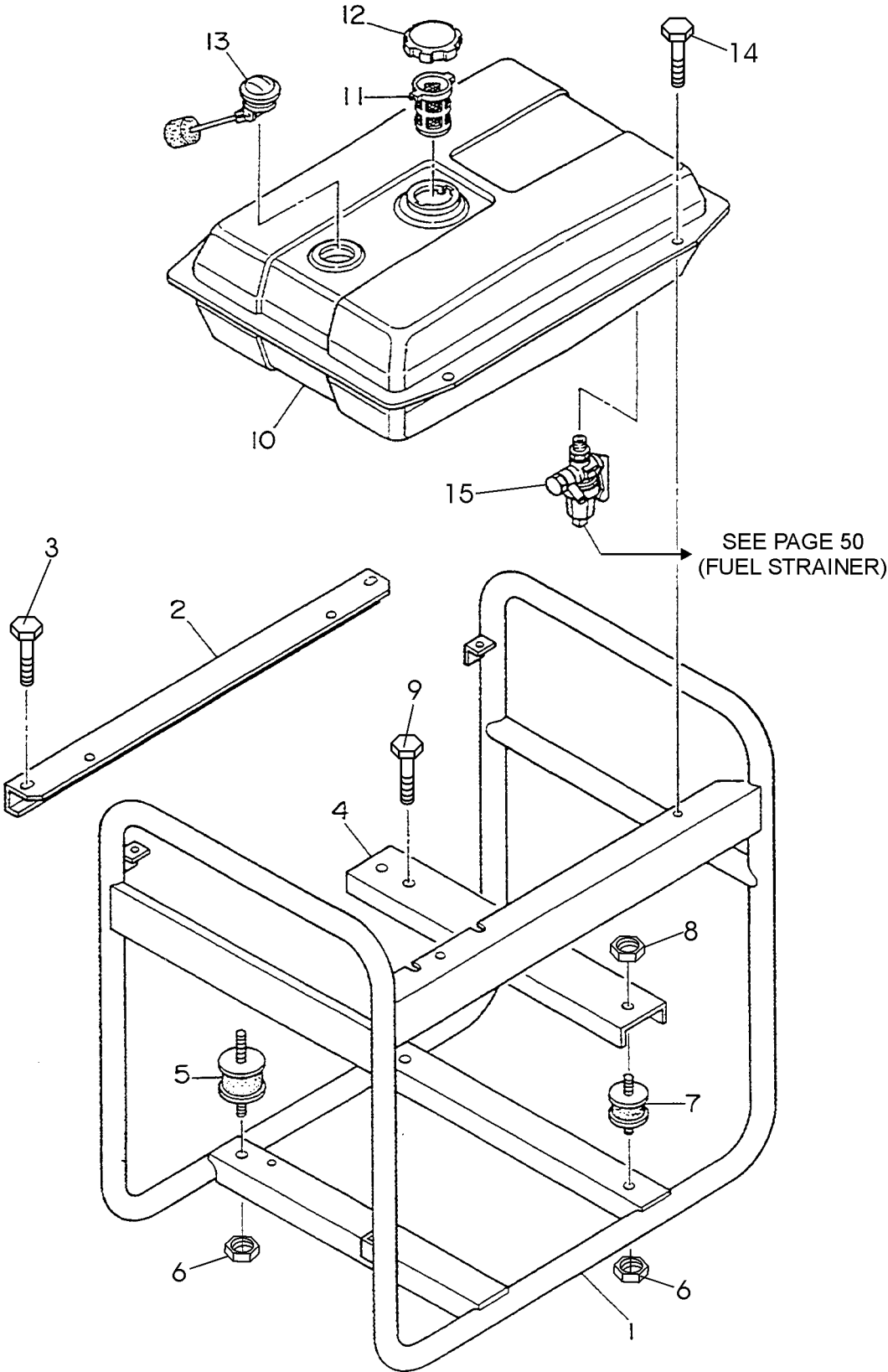

PIPE FRAME ASSY.

<u>NO</u>	<u>PART NO</u>	<u>PART NAME</u>	<u>QTY.</u>	<u>REMARKS</u>
1	7935400402	PIPE FRAME	1	
2	7935410403	BRACKET	1	
3	0017106016	HEX. HEAD BOLT	4	
4	7935410003	BASE	1	
5	0805084704	RUBBER SUSPENSION	2	
6	020108060	HEX. NUT	4	REPLACES 0207008000
7	7925419604	RUBBER SUSPENSION	2	
8	020108060	HEX. NUT	4	REPLACES 0207008000
9	0017108040	HEX. HEAD BOLT	2	
	020108060	HEX. NUT	2	REPLACES 0207008000
10	7945510102	FUEL TANK	1	
11	0810107103	FUEL FILTER	1	
12	0810106004	CAP, FUEL TANK	1	
13	0602125031	FUEL GAGE	1	
14	011008020	HEX. HEAD BOLT	4	REPLACES 0017108020
15	0642008900	FUEL STRAINER ASSY.	1	SEE PAGES 50 AND 51

GA-2.3R2 — NAME PLATE AND DECALS

NAME PLATE AND DECALS

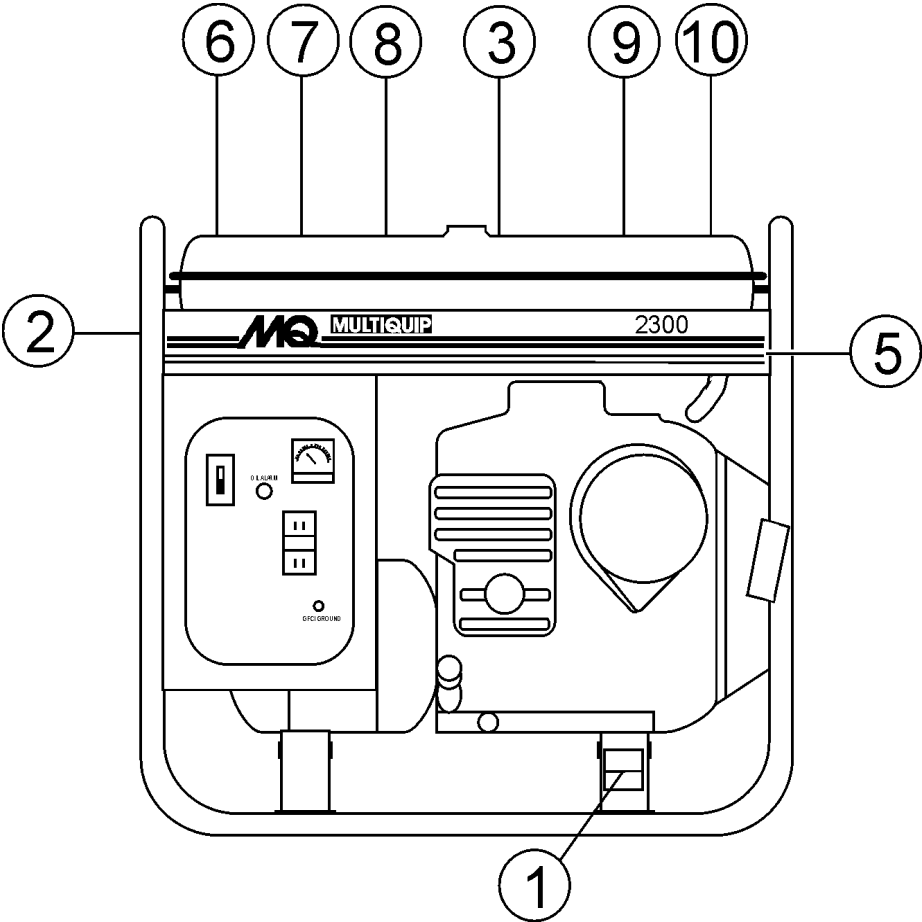

GA-2.3R2 — NAME PLATE AND DECALS

NAME PLATE AND DECALS

NO	PART NO	PART NAME	QTY	REMARKS
1*	0800628504	DECAL : GROUND	1	S-1123
2*	1980680004	DECAL : FUEL COCK	1	S-3704
3*	7900638204	DECAL : OPERATING INSTRUCTIONS	1	S-4605
4*	7930602302	DECAL : MQ GA-2.3R2	1	S-5245A
5*	7930615603	DECAL : MQ 2300	1	S-5246
6*	0820610804	DECAL : CAUTION	1	S-3311
7*	0820610404	DECAL : WARNING	1	S-3627
8*	7900636004	DECAL : OPERATE AT 3600 RPM ONLY	1	S-4461
9*	8700611804	DECAL : WARNING	1	S-4984
10*	8700611904	DECAL : DANGER	1	S-4985
11		PLATE, SERIAL NO.	1 CONTACT MQ SERVICE DEPT. W/MODEL & S/N
	DCLGA23R2	KIT, DECAL	1 INCLUDES ITEMS W/*

SEE DECAL ILLUSTRATIONS ON PAGE 7.

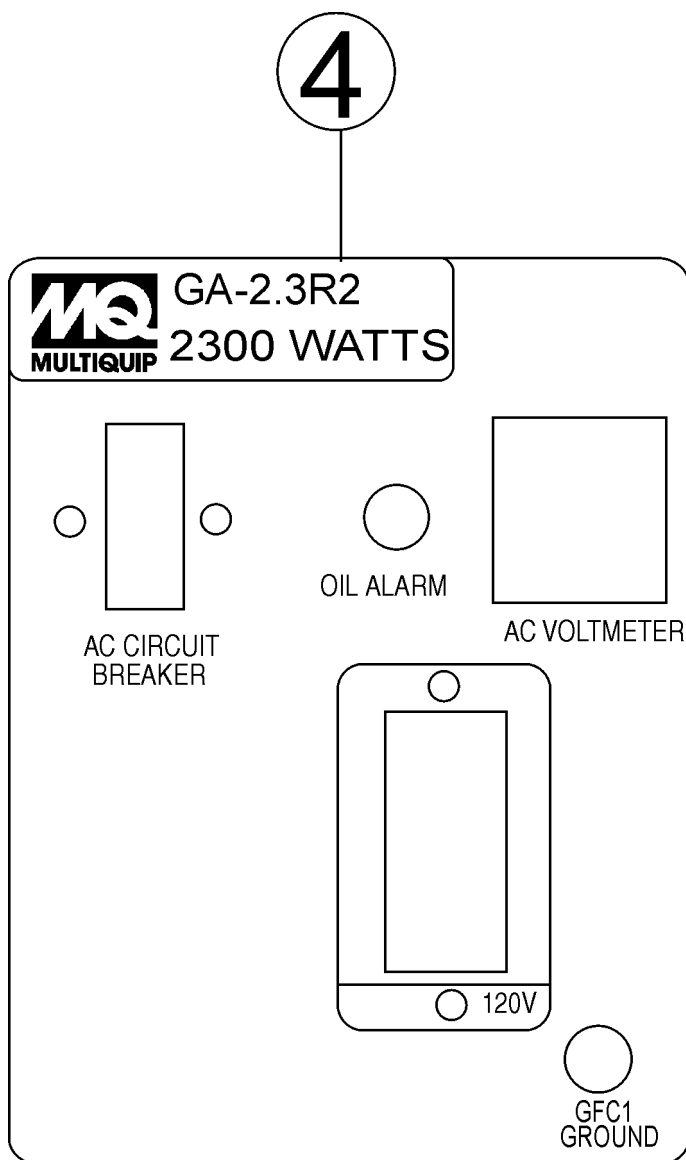

ROBIN EH-17 ENGINE — CRANKCASE ASSY.

CRANKCASE ASSY.

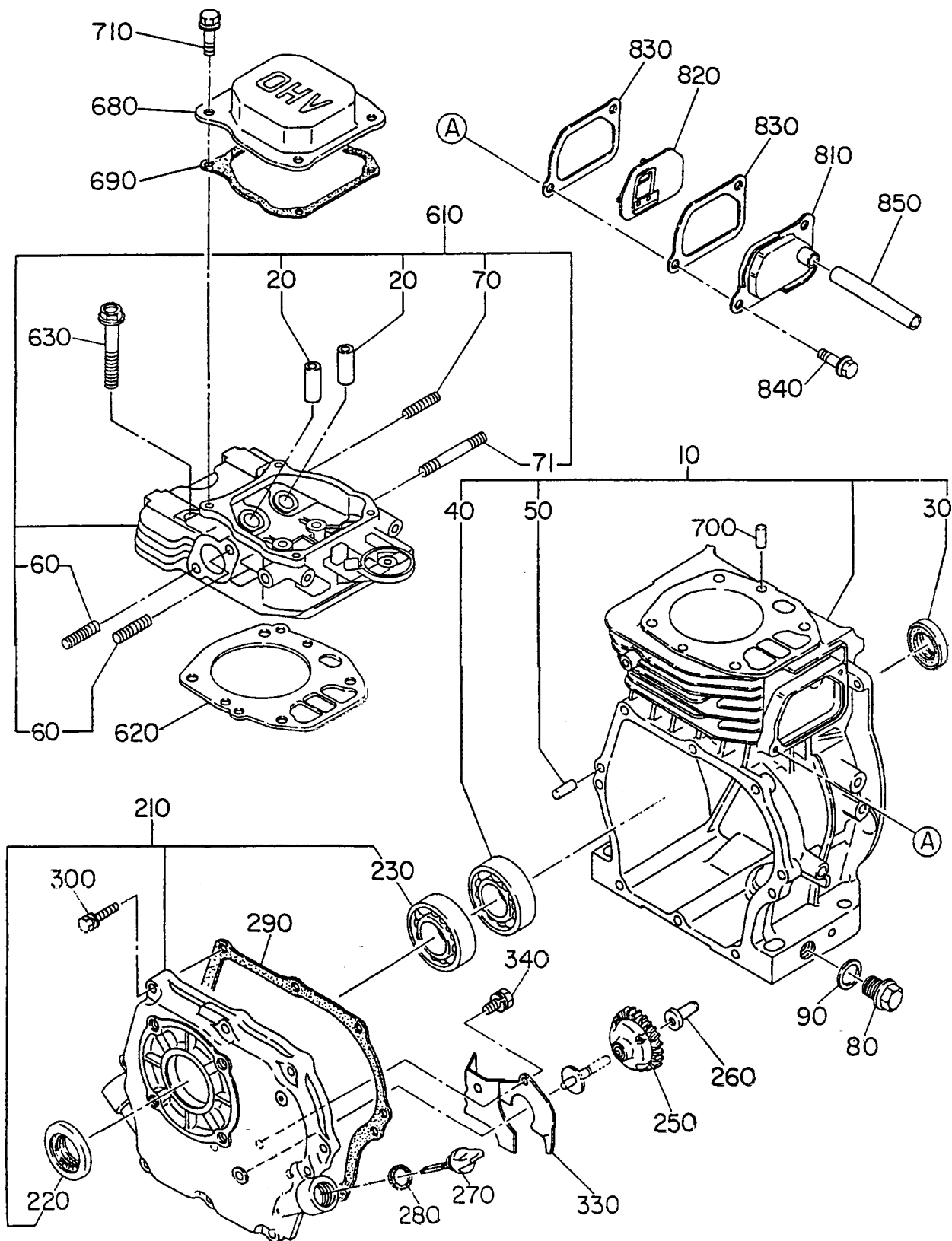

ROBIN EH-17 ENGINE — CRANKCASE ASSY.

CRANKCASE ASSY.

<u>NO.</u>	<u>PART NO.</u>	<u>PART NAME</u>	<u>QTY.</u>	<u>REMARKS</u>
10	2691010401	CRANK CASE CP	1	INCLUDES ITEMS W/#
20	2371420203	VALVE GUIDE	2	OVER SIZE
30#	0440250070	OIL SEAL	1	25X38X7
40#	0600250010	BALL BEARING	1	BB6205C3
50#	0310060020	DOWEL PIN	2	
60	0105080290	STUD	2	
70	0105060131	STUD	1	
71	0013906600	STUD	1	
80	0401140030	PLUG	2	
90	0211140020	GASKET	2	
210	2531101301	MAIN BEARING COVER	1	INCLUDES ITEMS W/%
220%	0440250160	OIL SEAL	1	25X41.24X7
230%	0600250010	BALL BEARING	1	BB6205C3
250	2274500301	GOVERNOR GEAR CP	1	
260	2054190103	GOVERNOR SLEEVE	1	
270	2696360103	OIL GAUGE	1	
280*	0213160020	GASKET	1	
290*	2531600203	GASKET (BEARING COVER)	1	
300	0130060040	BOLT & WASHER ASSEMBLY	8	
330	2531750113	SHELTER PLATE	1	
340	0043505100	SCREW & WASHER ASSEMBLY	2	
610	2691300101	CYLINDER HEAD CP	1	
620*	2531500123	GASKET (HEAD)	1	
630	0110080100	FLANGE BLOT	4	
680	2531550103	ROCKER COVER	1	
690*	2691600403	GASKET (ROCKER COVER)	1	
700	0310060020	DOWEL PIN	2	
710	0110060020	FLANGE BLOT	4	
810	2531430111	BREATHER COVER CP	1	
820	2531440111	BREATHER PLATE CP	1	I
830*	2531600633	GASKET (BREATHER COVER)	2	
840	0110060030	FLANGE BOLT	2	
850	0851080000	RUBBER PIPE	1	8X11X75
960	2539900107	GASKET SET	1	INCLUDES ITEMSW/* IN ADDITION SEE GASKETS FROM INTAKE & EXHAUST ASSY. (340,550,555 & 560)

ROBIN EH-17 ENGINE — CRANKSHAFT & PISTON ASSY.

CRANKSHAFT & PISTON ASSY.

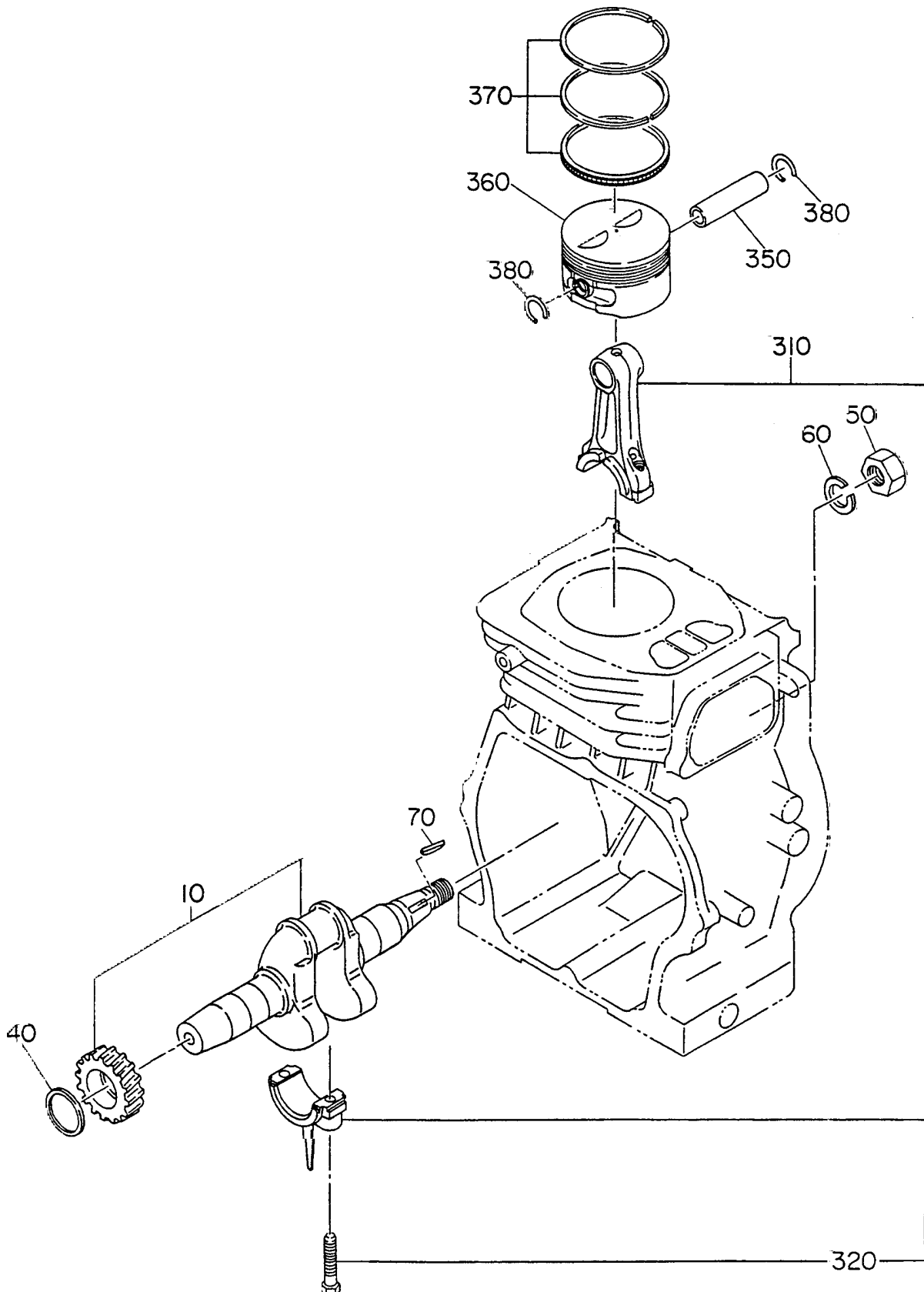

ROBIN EH-17 ENGINE — CRANKSHAFT & PISTON ASSY.

CRANKSHAFT & PISTON ASSY.

<u>NO.</u>	<u>PART NO.</u>	<u>PART NAME</u>	<u>QTY.</u>	<u>REMARKS</u>
10	2532070101	CRANKSHAFT CP	1	
40	0230250110	SPACER	1	T=0.6 SELECTIVE ASSEMBLY
	0230250120	SPACER	1	T=0.8 SELECTIVE ASSEMBLY
	0230250130	SPACER	1	T=1.0 SELECTIVE ASSEMBLY
50	0021814000	NUT	1	
60	0032014000	SPRING WASHER	1	
70	0323030010	WOODRUFF KEY	1	
310	2532250120	CONNECTING ROD ASSY.....	1	INCLUDES ITEMS W/#
320#	2512300103	CONNECTING ROD BOLT	2	
350	2692330103	PISTON PIN	1	
360	2692340103	PISTON	1	STANDARD
	2692340203	PISTON	1	OVER SIZE 0.25MM
	2692340303	PISTON	1	OVER SIZE 0.50MM
370	2532350117	PISTON RING SET	1	STANDARD
	2532350217	PISTON RING SET	1	OVER SIZE 0.25MM
	2532350317	PISTON RING SET	1	OVER SIZE 0.50MM
380	0565160010	CLIP	2	

ROBIN EH-17 ENGINE — INTAKE & EXHAUST ASSY.

INTAKE & EXHAUST ASSY.

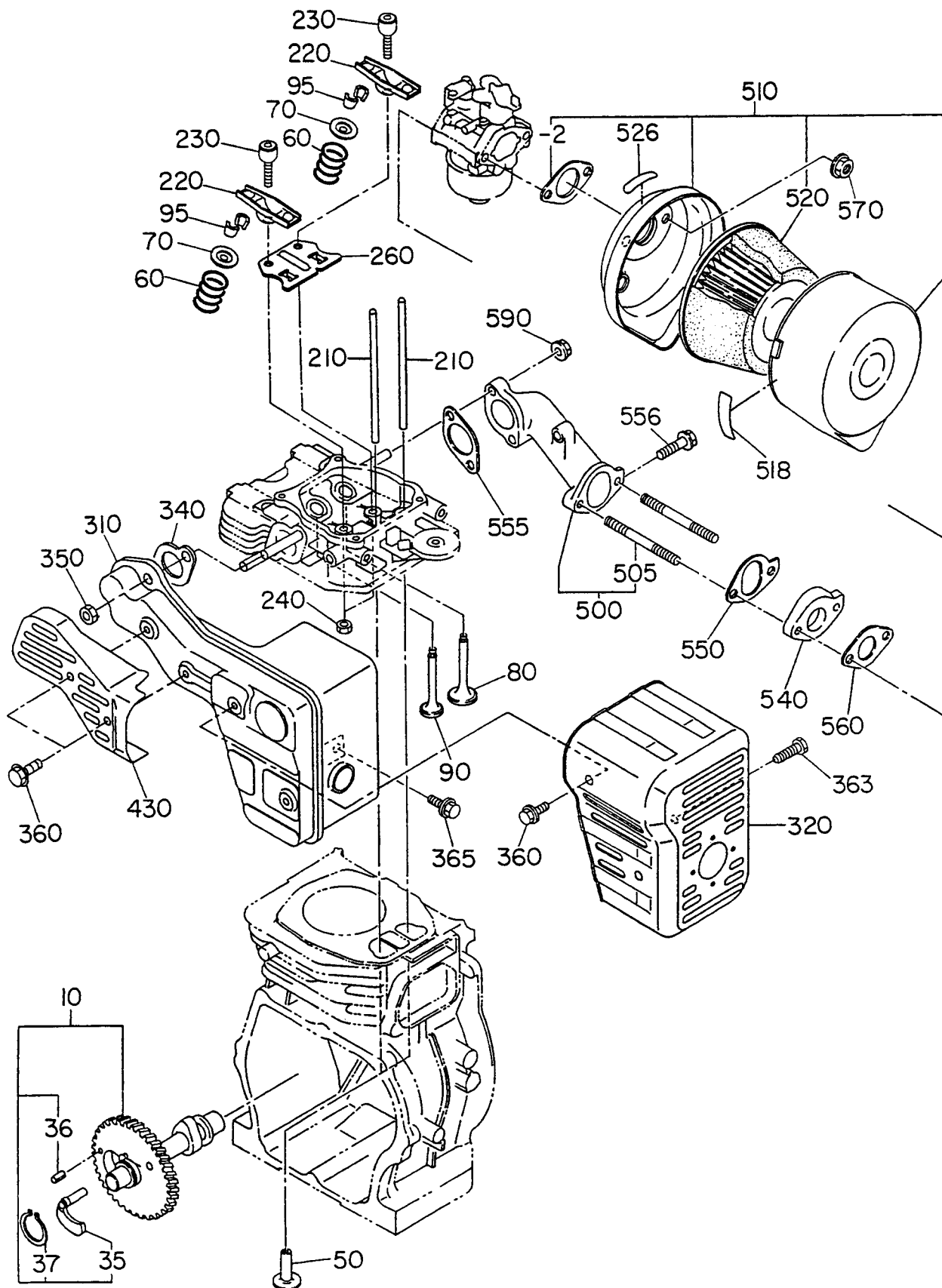

ROBIN EH-17 ENGINE — INTAKE & EXHAUST ASSY.

INTAKE & EXHAUST ASSY.

<u>NO.</u>	<u>PART NO.</u>	<u>PART NAME</u>	<u>QTY.</u>	<u>REMARKS</u>
10	2533170111	CAMSHAFT CP	1	INCLUDES ITEMS W/%
35%	2273640103	RELEASE LEVER	1	
36%	0051904100	SPRING PIN	1	
37%	0031522000	SNAP RING (OUTER)	1	
50	2393330113	TAPPET	2	
60	2533360103	VALVE SPRING	2	
70	13209KA040	RET. VALVE SPRING	2	
80	2693340103	INTAKE VALVE	1	
90	2693350103	EXHAUST VALVE	1	
95	13210KA031	COLLET-VALVE	4	
210	2693530103	PUSH ROD	2	
220	26136001A3	ROCKER ARM	2	INCLUDES ITEMS W/■
230■	2693580103	BOLT (PIVOT)	2	
240■	0170060090	NUT	2	
260	2693650103	GUIDE PLATE	1	
310	2693010101	MUFFLER CP	1	
320	2533420111	MUFFLER COVER	1	
340	2533520103	GASKET (MUFFLER)	1	
350	0170080030	NUT	2	
360	0045206103	TAPPING SCREW	4	
363	0152060080	TAPPING BOLT	1	
365	0110060020	FLANGE BOLT	1	
430	2693480103	EXHAUST PIPE COVER	1	
500	2533300101	INTAKE PIPE CP	1	INCLUDES ITEMS W/#
505#	0105060230	STUD	2	
510	2533261010	AIR CLEANER ASSEMBLY	1	INCLUDES ITEMS W/#
510-2#	2363263008	PACKING	1	
518	2539530113	LABEL (CLEANER ID)	1	
520#	2273261007	ELEMENT SET	1	
526	0732000150	LABEL, SHUTTER	1	
540	2533290103	INSULATOR	1	
550	2533590103	GASKET 3 (INSULATOR)	1	
555	2273590103	GASKET (INSULATOR)	1	
556	0110060130	FLANGE BOLT	1	
560	2363590303	GASKET 2 (INSULATOR)	1	
570	2263921200	NUT & WASHER ASSEMBLY	2	
590	0023806000	FLANGE NUT	2	

ROBIN EH-17 ENGINE — GOVERNOR ASSY.

GOVERNOR ASSY.

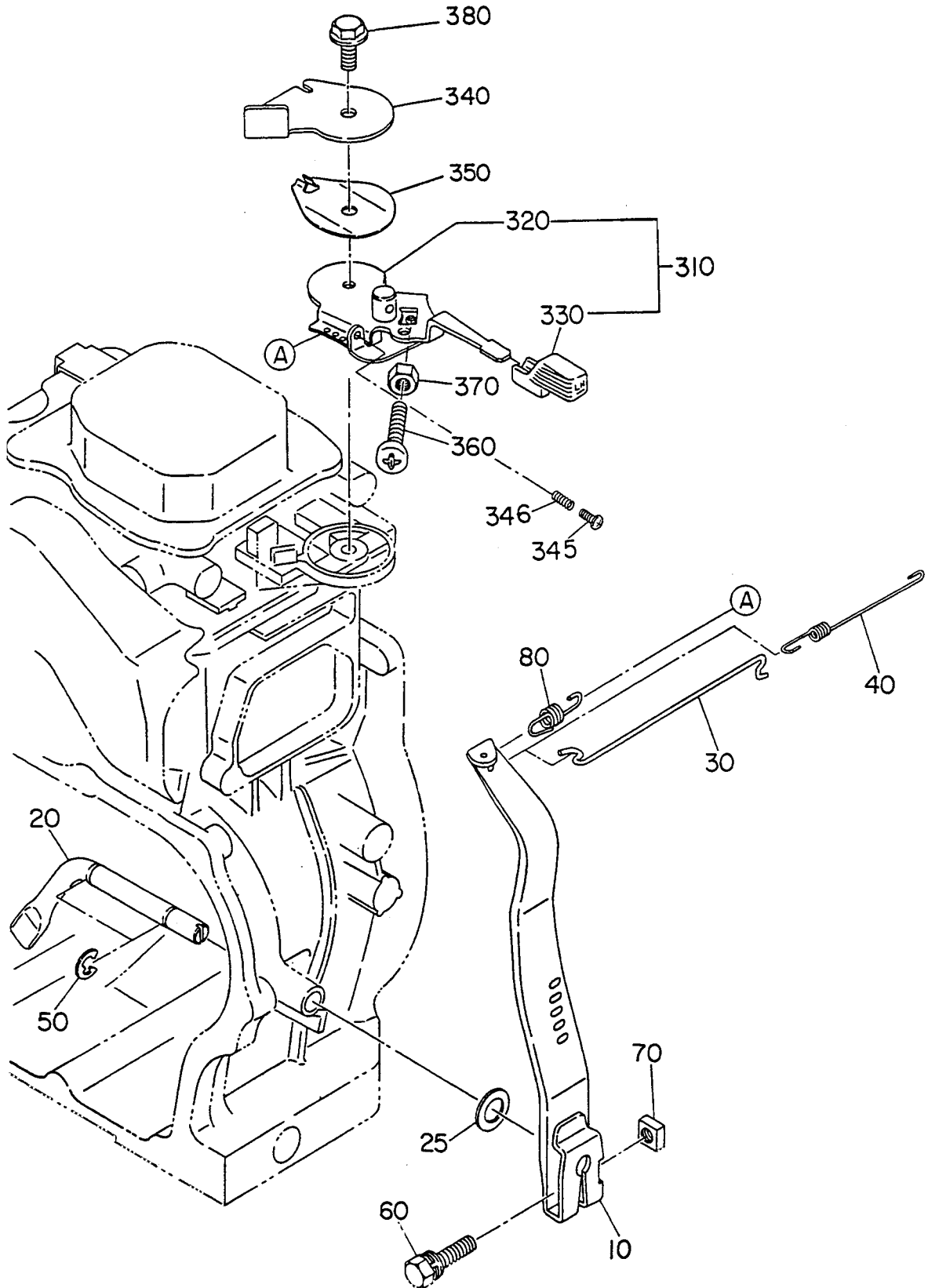

ROBIN EH-17 ENGINE — GOVERNOR ASSY.

GOVERNOR ASSY.

<u>NO.</u>	<u>PART NO.</u>	<u>PART NAME</u>	<u>QTY.</u>	<u>REMARKS</u>
10	2534230123	GOVERNOR LEVER	1	
20	2274220103	GOVERNOR SHAFT	1	
25	0031108000	WASHER	1	
30	2534270101	GOVERNOR ROD CP	1	
40	2534280103	ROD SPRING	1	
50	0031306000	CLIP	2	
60	0011406300	BOLT & WASHER ASSEMBLY	1	
70	0186060020	NUT	1	
80	2534250123	GOVERNOR SPRING	1	
310	2694330100	SPEED CONTROL ASSEMBLY	1	INCLUDES ITEMS W/#
320#	2694330101	SPEED CONTROL CP	1	
330#	2274360103	KNOB	1	
340	2694350103	STOP PLATE	1	
345	0043104300	SCREW, PANHEAD	1	
346	2694550303	IDLE SET SPRING	1	
350	2274500203	SPRING WASHER	1	
360	0043106300	SCREW	1	
370	0022706000	NUT	1	
380	0110060030	FLANGE BOLT	1	

ROBIN EH-17 ENGINE — COOLING & STARTING ASSY.

COOLING & STARTING ASSY.

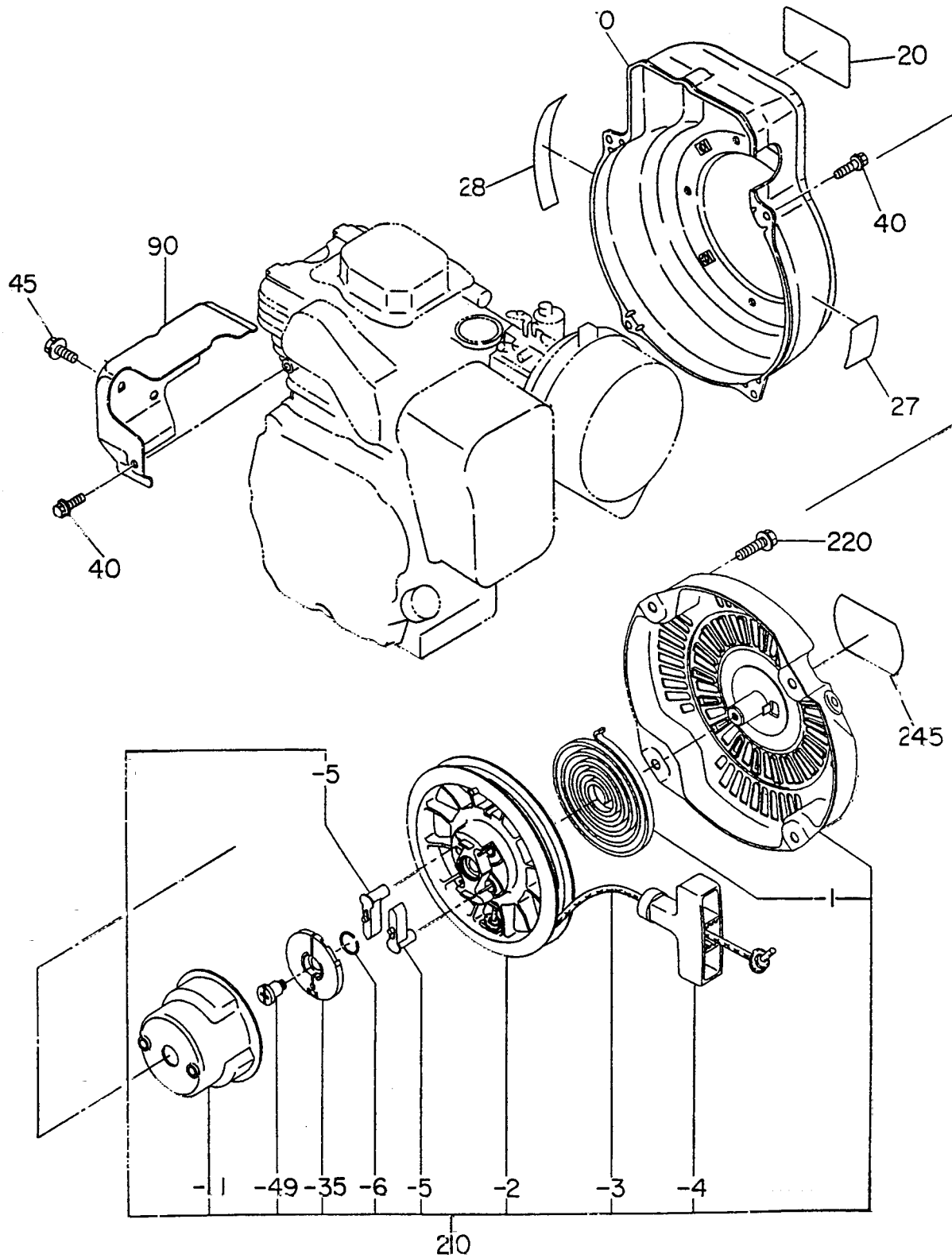

ROBIN EH-17 ENGINE — COOLING & STARTING ASSY.

COOLING & STARTING ASSY.

<u>NO.</u>	<u>PART NO.</u>	<u>PART NAME</u>	<u>QTY.</u>	<u>REMARKS</u>
10	2535126201	BLOWER HOUSING CP 2	1	
20	2699170303	TRADE MARK LABEL	1	
27	0732003900	WARNING LABEL	1	
28	2539520113	EMISSION CONTENT LABEL	1	
40	0110060020	FLANGE BOLT	5	
45	0110060030	FLANGE BOLT	2	
90	2535270103	HEAD COVER	1	
210	2695020100	RECOIL STARTER ASSEMBLY ...	1 INCLUDES ITEMS W/#
210-1#	2705011508	SPIRAL SPRING	1	
210-2#	2695012008	REEL	1	
210-3#	2695011008	STARTER ROPE	1	
210-4#	2615010008	STARTER KNOB	1	
210-5#	2705012508	RATCHET	2	
210-6#	2275013108	FRICTION SPRING	1	
210-11#	2695014508	STARTER PULLEY	1	
210-35#	2705026108	RATCHET GUIDE	1	
210-49#	2275015208	SET SCREW	1	
220	0110060010	FLANGE BOLT	4	
245	0732004950	OHV MARK LABEL	1	

ROBIN EH-17 ENGINE — FUEL & LUBRICANT ASSY.

FUEL & LUBRICANT ASSY.

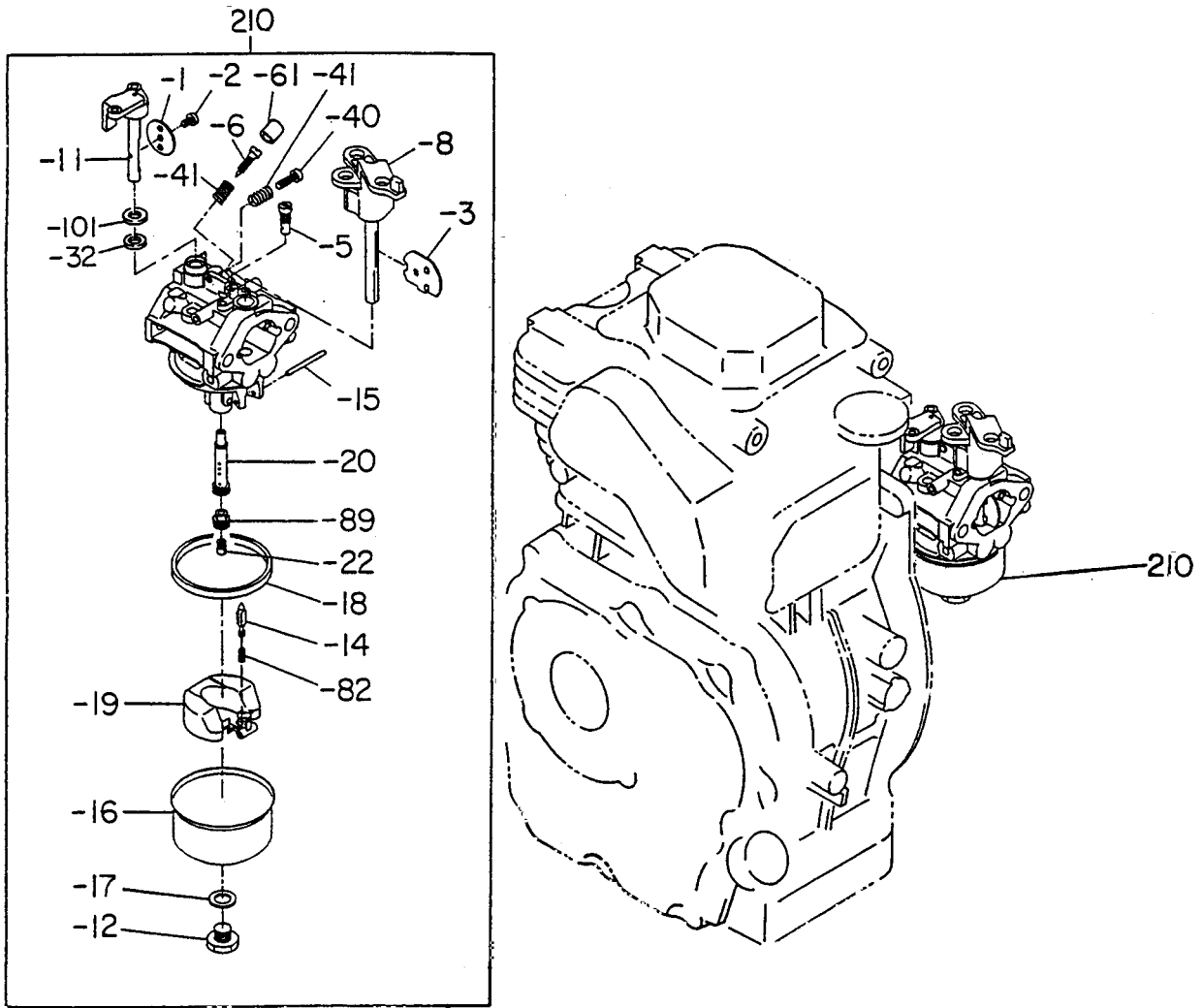

ROBIN EH-17 ENGINE — FUEL & LUBRICANT ASSY.

FUEL & LUBRICANT ASSY.

<u>NO.</u>	<u>PART NO.</u>	<u>PART NAME</u>	<u>QTY.</u>	<u>REMARKS</u>
210	2536245500	CARBURETOR AY.	1	INCLUDES ITEMS W/#
210-1#	2206253608	THROTTLE VALVE	1	
210-2#	2536235208	SCREW	1	
210-3#	2536252508	CHOKE VALVE	1	
210-5#	2536242008	PILOT JET	1	
210-6#	2466243608	PILOT SCREW	1	
210-8#	2536257008	CHOKE LEVER	1	
210-11#	2536253308	THROTTLE SHAFT - A	1	
210-12#	2366245108	BOLT	1	
210-14#	1616235208	NEEDLE	1	
210-15#	2366251008	PIN	1	
210-16#	2366255108	FLOAT CHAMBERBODY AY.	1	
210-17#	2366245008	PACKING	1	
210-18#	2366254008	PACKING	1	
210-19#	2366250508	FLOAT	1	
210-20#	2386244008	MAIN NOZZLE	1	
210-22#	2536240108	MAIN JET	1	
210-32#	1066239208	SEAL	2	
210-40#	2466243508	ADJUST SCREW	1	
210-41#	2096244508	SPRING	2	
210-89 #	2356242508	GUIDE HOLDER	1	
210-101#	2536235508	RING	1	

ROBIN EH-17 ENGINE — ELECTRIC COIL ASSY. AND SPARK PLUG

ELECTRIC COIL ASSY. AND SPARK PLUG

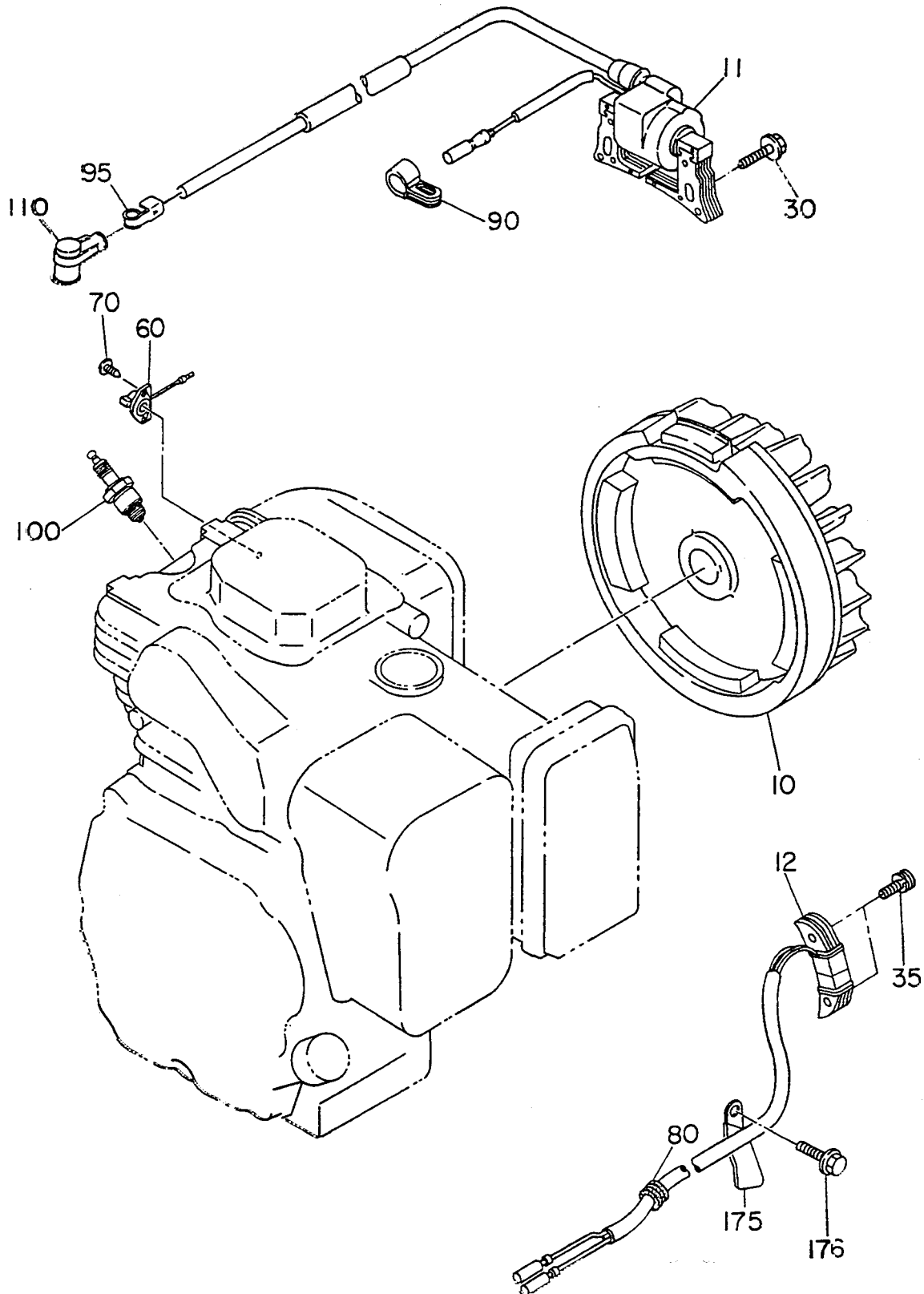

ROBIN EH-17 ENGINE — ELECTRIC COIL ASSY. AND SPARK PLUG

ELECTRIC COIL ASSY. AND SPARK PLUG

<u>NO.</u>	<u>PART NO.</u>	<u>PART NAME</u>	<u>QTY.</u>	<u>REMARKS</u>
10	2697934001	FLYWHEEL CP	1	
11	2697943001	IGNITION COIL CP	1	
12	2537967001	EXCITER COIL CP	1	
30	0011406250	BOLT & WASHER ASSY.	2	
35	0043506250	SCREW & WASHER ASSY.	2	
60	0660000361	SWITCH ASSY.	1	
70	0150040090	TAPPING SCREW	2	
80	0241080010	GROMMET	1	
90	0566120050	CLAMP	1	
95	0659000010	PLUG TERMINAL	1	
100	0650140150	SPARK PLUG	1	BR6HS
110	0655000140	SPARK PLUG CAP	1	
175	2247700201	WIRE CLAMP CP	1	
176	0110060010	FLANGE BOLT	1	

ROBIN EH-17 ENGINE — OIL SENSOR ASSY.

OIL SENSOR ASSY.

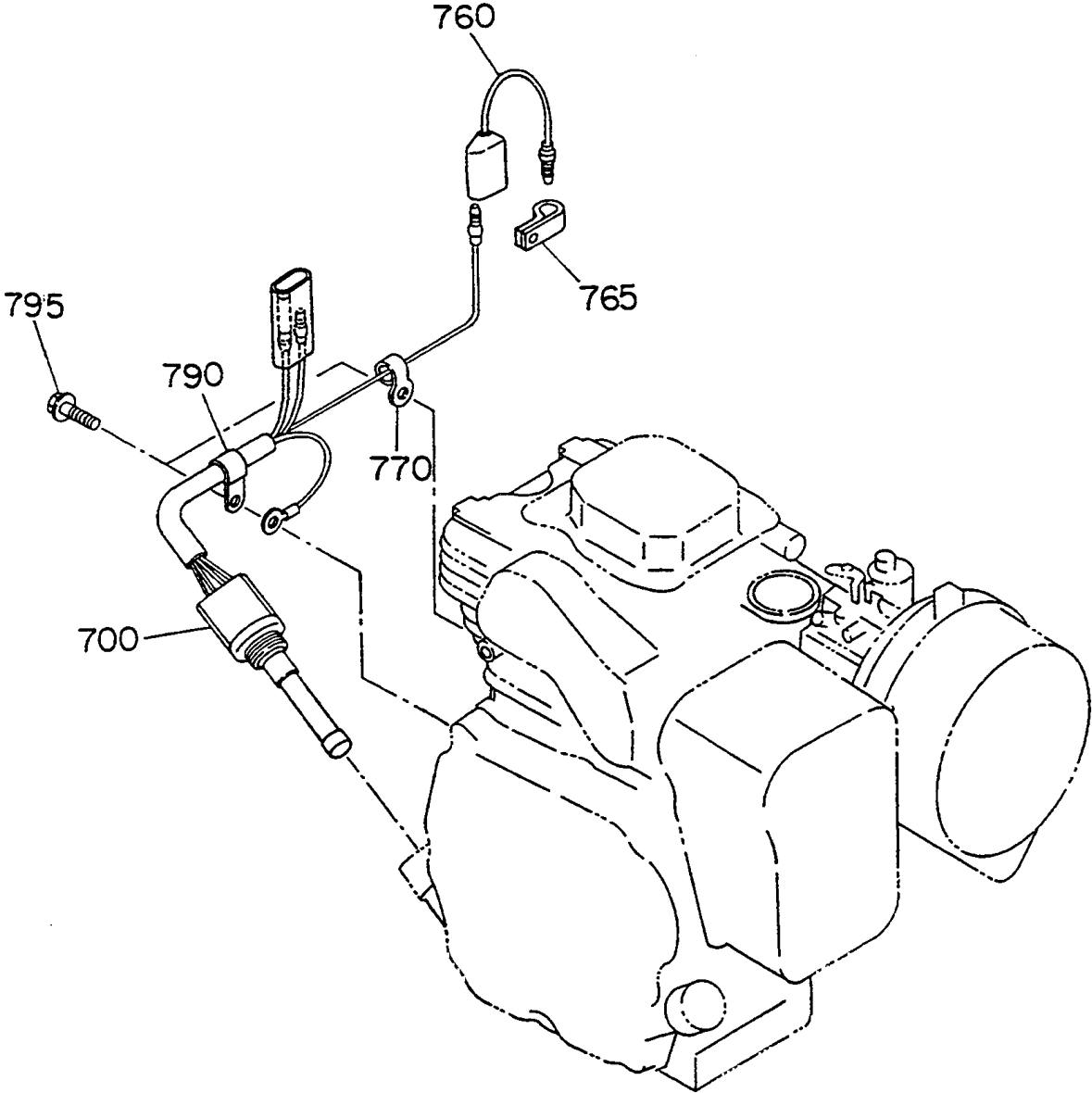

ROBIN EH-17 ENGINE — OIL SENSOR ASSY.

OIL SENSOR ASSY.

<u>NO.</u>	<u>PART NO.</u>	<u>PART NAME</u>	<u>QTY.</u>	<u>REMARKS</u>
700	KS31102301	OIL SENSOR CP 14	1	
760	2147312201	WIRE 22 CP	1	
765	2067550101	CLAMP CP	1	
770	2077500101	CLAMP CP	1	
790	2147900301	CLAMP CP	1	
795	0011008160	BOLT & WASHER ASSY.	3	

ROBIN EH-17 ENGINE — FUEL STRAINER

FUEL STRAINER ASSY.

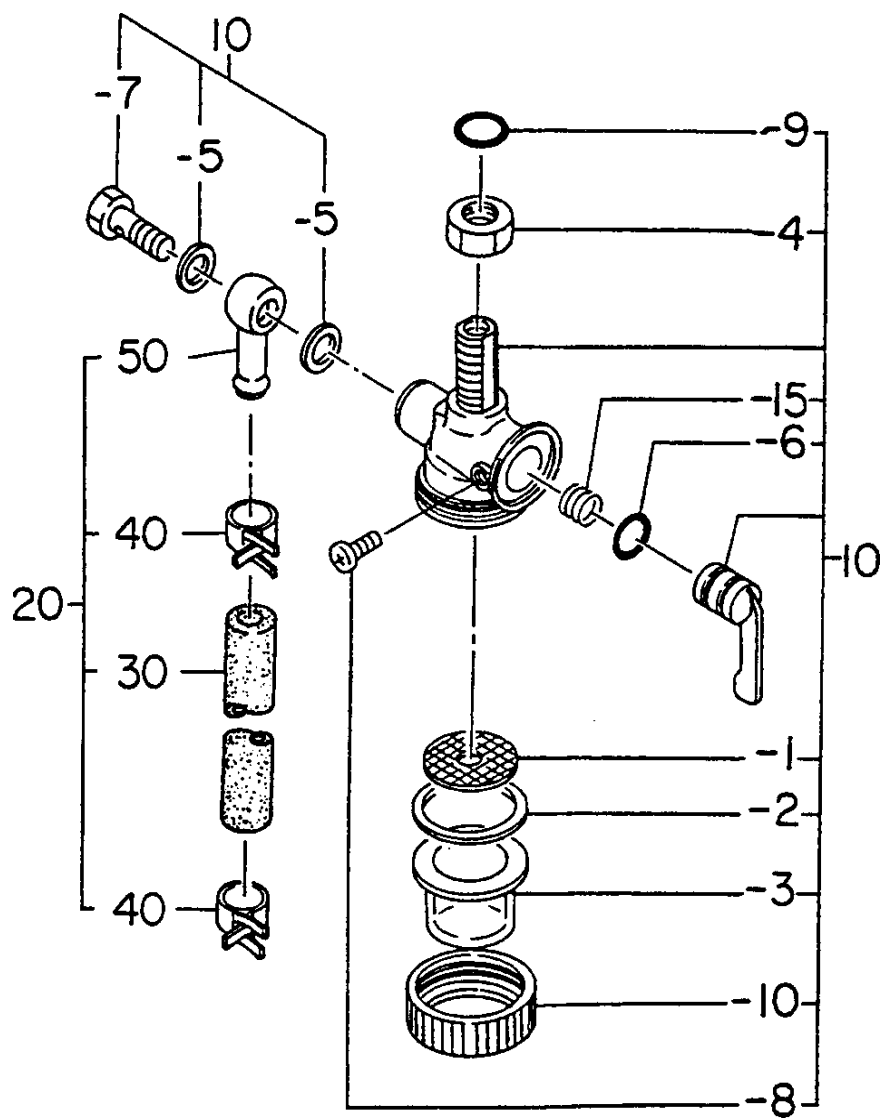

ROBIN EH-17 ENGINE — FUEL STRAINER

FUEL STRAINER ASSY.

<u>NO.</u>	<u>PART NO.</u>	<u>PART NAME</u>	<u>QTY.</u>	<u>REMARKS</u>
10	0642008900	FUEL STRAINER ASSY.	1	INCLUDES ITEMS W/# REPLACES 0605510024
10-1#	0642000220	FILTER	1	
10-2#	0642000230	GASKET	1	
10-3#	0642001910	CUP (NYLON)	1	
10-4#	0642002360	LOCK NUT	1	
10-5#	0642000250	GASKET	2	
10-6#	0642000330	O--RING	1	
10-7#	0642000240	BANJO BOLT	1	
10-8#	0642002790	LOCK BOLT	1	
10-9#	0642000330	O--RING	1	
10-10#	0642002410	LOCK NUT	1	
10-15#	0642003230	SPRING	1	
20	2696260401	FUEL PIPE 4 CP	1	INCLUDES ITEMS W/*
30*	2696800403	RUBBER PIPE	1	
40*	0561110020	HOSE CLAMP	2	
50*	0521070042	BANJO	1	

PAYMENT TERMS

Terms of payment for parts are net 10 days.

FREIGHT POLICY

All parts orders will be shipped collect or prepaid with the charges added to the invoice. All shipments are F.O.B. point of origin. Multiquip's responsibility ceases when a signed manifest has been obtained from the carrier, and any claim for shortage or damage must be settled between the consignee and the carrier.

MINIMUM ORDER

The minimum charge for orders from Multiquip is \$15.00 net. Customers will be asked for instructions regarding handling of orders not meeting this requirement.

RETURNED GOODS POLICY

Return shipments will be accepted and credit will be allowed, subject to the following provisions:

1. A Returned Material Authorization must be approved by Multiquip prior to shipment.
2. To obtain a Return Material Authorization, a list must be provided to Multiquip Parts Sales that defines item numbers, quantities, and descriptions of the items to be returned.
 - a. The parts numbers and descriptions must match the current parts price list.
 - b. The list must be typed or computer generated.
 - c. The list must state the reason(s) for the return.
 - d. The list must reference the sales order(s) or invoice(s) under which the items were originally purchased.
 - e. The list must include the name and phone number of the person requesting the RMA.
3. A copy of the Return Material Authorization must accompany the return shipment.
4. Freight is at the sender's expense. All parts must be returned freight prepaid to Multiquip's designated receiving point.
5. Parts must be in new and resalable condition, in the original Multiquip package (if any), and with Multiquip part numbers clearly marked.
6. The following items are not returnable:
 - a. Obsolete parts. (If an item is listed in the parts price book as being replaced by another item, it is obsolete.)
 - b. Any parts with a limited shelf life (such as gaskets, seals, "O" rings, and other rubber parts) that were purchased more than six months prior to the return date.
 - c. Any line item with an extended dealer net price of less than \$5.00.
 - d. Special order items.
 - e. Electrical components.
 - f. Paint, chemicals, and lubricants.
 - g. Decals and paper products.
 - h. Items purchased in kits.
7. The sender will be notified of any material received that is not acceptable.
8. Such material will be held for 5 working days from notification, pending instructions. If a reply is not received within 5 days, the material will be returned to the sender at his expense.
9. Credit on returned parts will be issued at dealer net price at time of the original purchase, less a 15% restocking charge.
10. In cases where an item is accepted for which the original purchase document can not be determined, the price will be based on the list price that was effective twelve months prior to the RMA date.
11. Credit issued will be applied to future purchases only.

PRICING AND REBATES

Prices are subject to change without prior notice. Price changes are effective on a specific date and all orders received on or after that date will be billed at the revised price. Rebates for price declines and added charges for price increases will not be made for stock on hand at the time of any price change.

Multiquip reserves the right to quote and sell direct to Government agencies, and to Original Equipment Manufacturer accounts who use our products as integral parts of their own products.

SPECIAL EXPEDITING SERVICE

A \$20.00 to \$50.00 surcharge will be added to the invoice for special handling including bus shipments, insured parcel post or in cases where Multiquip must personally deliver the parts to the carrier.

LIMITATIONS OF SELLER'S LIABILITY

Multiquip shall not be liable here under for damages in excess of the purchase price of the item with respect to which damages are claimed, and in no event shall Multiquip be liable for loss of profit or good will or for any other special, consequential or incidental damages.

LIMITATION OF WARRANTIES

No warranties, express or implied, are made in connection with the sale of parts or trade accessories nor as to any engine not manufactured by Multiquip. Such warranties made in connection with the sale of new, complete units are made exclusively by a statement of warranty packaged with such units, and Multiquip neither assumes nor authorizes any person to assume for it any other obligation or liability whatever in connection with the sale of its products. A part from such written statement of warranty, there are no warranties, express, implied or statutory, which extend beyond the description of the products on the face hereof.

PARTS AND OPERATION MANUAL

HERE'S HOW TO GET HELP

*PLEASE HAVE THE MODEL AND SERIAL NUMBER
ON-HAND WHEN CALLING*

PARTS DEPARTMENT

800-427-1244 or 310-537-3700

FAX: 800-672-7877 or 310-637-3284

SERVICE DEPARTMENT/TECHNICAL ASSISTANCE

800-478-1244 or 310-537-3700

FAX: 310- 537-4259

WARRANTY DEPARTMENT

888-661-4279, or 310-661-4279

FAX: 310- 537-1173

MAIN

800-421-1244 or 310-537-3700

FAX: 310-537-3927

Manufactured for MULTQUIP INC.
by
DENYO MANUFACTURING CO., JAPAN



MULTQUIP INC.
POST OFFICE BOX 6254
CARSON, CA 90749
310-537-3700 • 800-421-1244
FAX: 310-537-3927
E-MAIL: mq@multiquip.com
WWW: multiquip.com

Atlanta • Boise • Dallas • Houston • Newark
Quebec, Canada • Manchester, UK • Rio De Janeiro, BR • Guadalajara, MX