

OPERATION AND PARTS MANUAL



MODEL GA-2.9R PORTABLE AC GENERATOR (GASOLINE ENGINE)

Revision #0 (10/28/04)

**THIS MANUAL MUST ACCOMPANY
THE EQUIPMENT AT ALL TIMES.**



WARNING

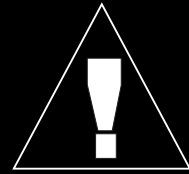

CALIFORNIA — Proposition 65 Warning

Engine exhaust and some of its constituents are known to the State of California to cause cancer, birth defects and other reproductive harm.

HERE'S HOW TO GET HELP

PLEASE HAVE THE MODEL AND SERIAL
NUMBER *ON-HAND* WHEN CALLING

MULTIQUIP CORPORATE OFFICE

18910 Wilmington Ave. 800-421-1244
Carson, CA 90746 FAX: 310-537-3927
Email: mq@multiquip.com
Internet: www.multiquip.com

PARTS DEPARTMENT

800-427-1244 FAX: 800-672-7877
310-537-3700 FAX: 310-637-3284

MAYCO PARTS

800-306-2926 FAX: 800-672-7877
310-537-3700 FAX: 310-637-3284

SERVICE DEPARTMENT

800-421-1244 FAX: 310-537-4259
310-537-3700

TECHNICAL ASSISTANCE

800-478-1244 FAX: 310-631-5032

WARRANTY DEPARTMENT

800-421-1244, EXT. 279 FAX: 310-537-1173
310-537-3700, EXT. 279

© COPYRIGHT 2004, MULTIQUIP INC.

Multiquip Inc, the MQ logo are registered trademarks of Multiquip Inc. and may not be used, reproduced, or altered without written permission. All other trademarks are the property of thier respective owners and used with permission.

This manual MUST accompany the equipment at all times. This manual is considered a permanent part of the equipment and should remain with the unit if resold.

The information and specifications included in this publication were in effect at the time of approval for printing. Illustrations are based on the *MQ GA-2.9R Portable Generator*. Illustrations, descriptions, references and technical data contained in this manual are for guidance only and may not be considered as binding. Multiquip Inc. reserves the right to discontinue or change specifications, design or the information published in this publication at any time without notice and without incurring any obligations.

**To find the latest revision of this
publication, visit our website at:
www.multiquip.com**



MQ GA-2.9R — AC Portable Generator

| | |
|--|-------|
| Here's How To Get Help | 3 |
| Table Of Contents | 4 |
| Parts Ordering Procedures | 5 |
| Dimensions | 6 |
| Specifications | 7 |
| Safety Alert Message Symbols | 8-9 |
| Rules for Safe Operation | 10-12 |
| Operation and Safety Decals | 13 |
| General Information | 14 |
| Load Application | 15 |
| Controls and Indicators | 16-17 |
| Generator Refueling | 18 |
| Installation | 19-20 |
| Pre-Inspection | 21 |
| Pre-Inspection (Engine) | 22 |
| Initial Start-up (Engine) | 23 |
| Initial Start-up (Engine/Operation) | 24 |
| Preparation For Long Term Storage | 25 |
| Maintenance | 26-27 |
| Wiring Diagram | 28 |
| Troubleshooting (Engine) | 29-30 |
| Troubleshooting (Generator) | 31 |
| Explanation Of Codes In Remarks Column | 32 |
| Suggested Spare Parts | 33 |

ROBIN EX170D20210 Engine (EPA)

| | |
|--|-------|
| Crankcase Assembly | 42-43 |
| Crankshaft, Piston Assembly | 44-45 |
| Governor Assembly | 46-47 |
| Intake and Exhaust Assembly | 48-49 |
| Air Cleaner Assembly | 50-51 |
| Cooling Starting Assembly | 52-53 |
| Carburetor Assembly | 54-55 |
| Flywheel Assembly | 56-57 |
| Electric Device Assembly | 58-59 |
| Terms and Conditions Of Sale — Parts | 60 |

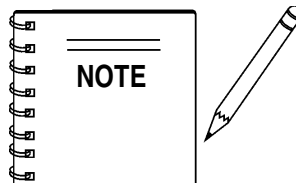

As a continuing effort to update our parts book, contact the MQ literature department for the latest revision of your "Operation and Parts Manual"

Generator Component Drawings

| | |
|----------------------------|-------|
| Nameplate and Decals | 34-35 |
| Generator Assembly | 36-37 |
| Control Box Assembly | 38-39 |
| Pipe Frame Assembly | 40-41 |

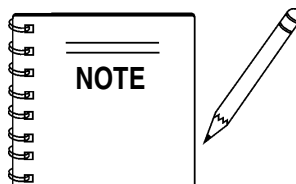

Specification and part number are subject to change without notice.

PARTS ORDERING PROCEDURES

When ordering parts, please supply the following information:

- Dealer account number
- Dealer name and address
- Shipping address (if different than billing address)
- Return fax number
- Applicable model number
- Quantity, part number and description of each part
- Specify preferred method of shipment:
 - ✓ FedEx or UPS Ground
 - ✓ FedEx or UPS Second Day or Third Day
 - ✓ FedEx or UPS Next Day
 - ✓ Federal Express Priority One
 - ✓ DHL
 - ✓ Truck

Note: Unless otherwise indicated by customer, all orders are treated as "Standard Orders", and will ship within 24 hours. We will make every effort to ship "Air Shipments" the same day that the order is received, if prior to 2PM west coast time. "Stock Orders" must be so noted on fax or web forms.



Here's how to get help...

Please have the model and serial number on hand when calling.

MULTIQUIP CORPORATE OFFICE

18910 Wilmington Ave. 800-421-1244
 Carson, CA 90746 FAX: 310-537-3927
 Email: mq@multiquip.com
 Internet: www.multiquip.com

PARTS DEPARTMENT

800-427-1244 FAX: 800-672-7877
 310-537-3700 FAX: 310-637-3284

MAYCO PARTS

800-306-2926 FAX: 800-672-7877
 310-537-3700 FAX: 310-637-3284

SERVICE DEPARTMENT

800-421-1244 FAX: 310-537-4259
 310-537-3700

TECHNICAL ASSISTANCE

800-478-1244 FAX: 310-631-5032

WARRANTY DEPARTMENT

800-421-1244, EXT. 279 FAX: 310-537-1173
 310-537-3700, EXT. 279

Place Your Parts Order Via Web or Fax For Even More Savings!

(Domestic USA Dealers Only)

Extra Discounts!

All parts orders which include complete part numbers and are received by our automated web parts order system, or by fax qualify for the following extra discounts:

| Ordered via | Standard orders | Stock orders (\$750 list and above) |
|-------------|-----------------|-------------------------------------|
| Fax | 3% | 10% |
| Web | 5% | 10% |

Special freight allowances when you order 10 or more line items via Web or Fax! **

FedEx Ground Service **at no charge for freight**

No other allowances on freight shipped by any other carrier.

****Common nuts, bolts and washers (all items under \$1.00 list price) do not count towards the 10+ line items.**

NOTE: DISCOUNTS ARE SUBJECT TO CHANGE



MULTIQUIP INC.
 18910 WILMINGTON AVENUE
 POST OFFICE BOX 6254
 CARSON, CALIFORNIA 90749
 310-537-3700 • 800-421-1244
 FAX: 310-537-3927
 E-MAIL: mq@multiquip.com
 INTERNET: www.multiquip.com

Direct TOLL-FREE access to our Parts Department:

Toll-free nationwide — 800-427-1244

Toll-free FAX — 800-6-PARTS-7 (800/672-7877)

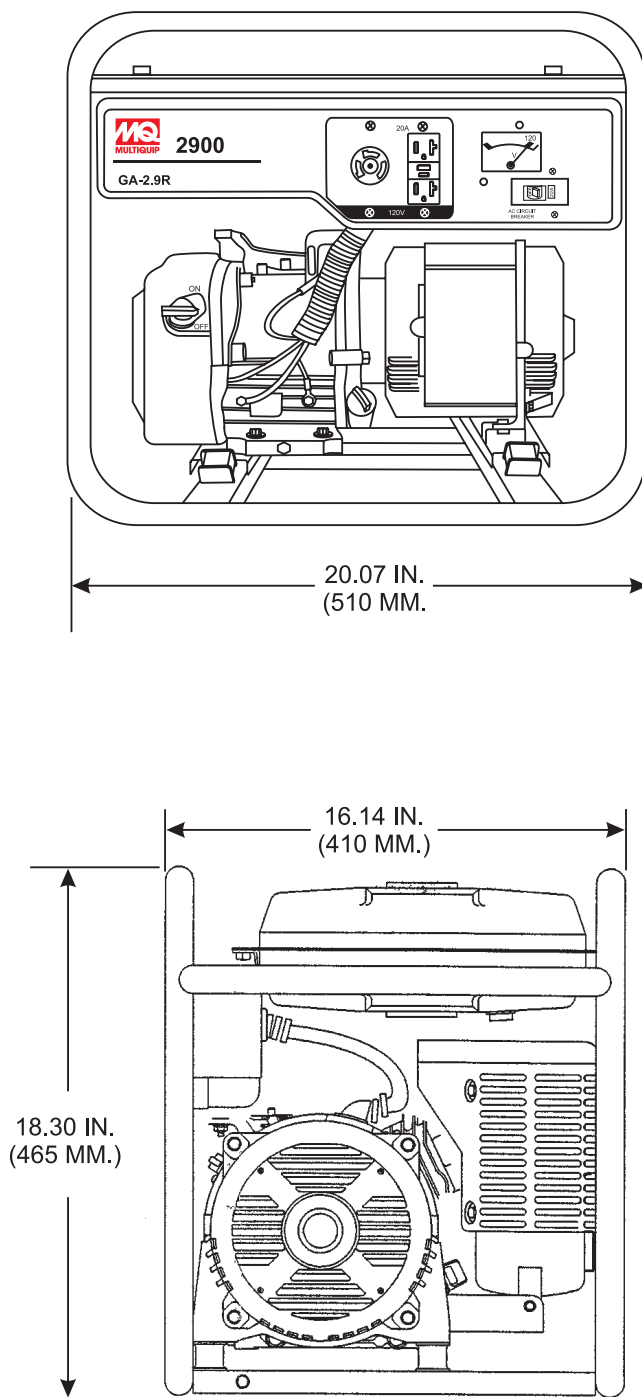

Figure 1. Dimensions

Table 1. Specifications

| MODEL | | GA-2.9R |
|------------------|---|--|
| GENERATOR | Type | 2-Pole, Brushless Type Revolving Field |
| | Frequency (Hz) | 60 |
| | Continuous Output (kW) | 2.6 |
| | Maximum Output (kW) | 2.9 |
| | Voltages (VAC) | 120 |
| | Max/Continuous Amps 120 VAC | 24.2/21.7 |
| | Rated Speed (RPM) | 3600 |
| | Power Factor | 1.0 |
| | Dimension (L x W x H) in. (mm) | 20 X 16 X 18 (510 X 410 X 465) |
| | Dry Net Weight lbs. (kg) Includes Engine | 108 (49) |
| ENGINE | Model | ROBIN EX170D20210 |
| | Type | Air-cooled, 4-stroke, Single Cylinder, Overhead Camshaft, Gasoline Engine |
| | Displacement (cc) | 169 |
| | Continuous Output (kW/min) | 2.9 @3600 |
| | Maximum Output (kW/min) | 5.7 @4000 |
| | Fuel Tank Capacity Gal. (L) | 3.17 (12) |
| | Fuel | Non-leaded Automobile Gasoline |
| | Lube Oil Capacity Qts. (L) | 0.63 (0.6) |
| | Speed Control Method | Centrifugal Fly-weight Type |
| | Starting Method | Recoil Start |
| | Dimension (L x W x H) in. (mm) | 11.96 X 13.93 X 13.18 (304 X 354 X 335) |
| | Dry Net Weight lbs. (kg) | 33.06 (15) |

Effects of Altitude and Heat

The maximum output of the engine listed above is applicable to supplying electrical power for continuous service at ambient conditions in accordance with SAE Test cord J607. The above ambient conditions are at standard sea level, with a barometric reading of 29.92 inches and a temperature of 60 degrees Fahrenheit.

Generally, the engine output power will decrease 3 1/2% for each 1000 feet of altitude above sea level, and 1% for each 10° F fahrenheit above the standard temperature of 60° F.

MQ GA-2.9R— SAFETY MESSAGE ALERT SYMBOLS

FOR YOUR SAFETY AND THE SAFETY OF OTHERS!

Safety precautions should be followed at all times when operating this equipment. Failure to read and understand the Safety Messages and Operating Instructions could result in injury to yourself and others.

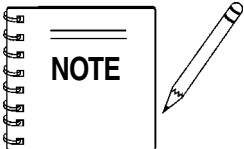

This Owner's Manual has been developed to provide complete instructions for the safe and efficient operation of the **MQ Model GA-2.9R Portable Generator**. Refer to the engine manufacturers instructions for data relative to its safe operation.

Before using this generator, ensure that the operating individual has read and understands all instructions in this manual.

SAFETY MESSAGE ALERT SYMBOLS

The three (3) Safety Messages shown below will inform you about potential hazards that could injure you or others. The Safety Messages specifically address the level of exposure to the operator, and are preceded by one of three words: **DANGER**,

DANGER

You **WILL** be **KILLED** or **SERIOUSLY INJURED** if you **DO NOT** follow these directions.

WARNING

You **CAN** be **KILLED** or **SERIOUSLY INJURED** if you **DO NOT** follow these directions.

CAUTION

You **CAN** be **INJURED** if you **DO NOT** follow these directions.

HAZARD SYMBOLS

Potential hazards associated with the operation of a **MQ GA-2.9R Portable Generator** will be referenced with Hazard Symbols which appear throughout this manual, and will be referenced in conjunction with Safety Message Alert Symbols.

WARNING Lethal Exhaust Gas Hazards

Engine exhaust gases contain poisonous carbon monoxide. This gas is colorless and odorless, and can cause death if inhaled. **NEVER** operate this equipment in a confined area or enclosed structure that does not provide ample free flow air.



WARNING Explosive Fuel Hazards

Gasoline is extremely flammable, and its vapors can cause an explosion if ignited. **DO NOT** start the engine near spilled fuel or combustible fluids.



DO NOT fill the fuel tank while the engine is running or hot. **DO NOT** overfill tank, since spilled fuel could ignite if it comes into contact with hot engine parts or sparks from the ignition system. Store fuel in approved containers, in well-ventilated areas and away from sparks and flames.

WARNING Burn Hazards

Engine components can generate extreme heat. To prevent burns, **DO NOT** touch these areas while the engine is running or immediately after operations. Never operate the engine with heat shields or heat guards removed.



WARNING Respiratory Hazards

ALWAYS wear approved **respiratory** protection when required.



MQ GA-2.9R— SAFETY MESSAGE ALERT SYMBOLS

CAUTION

Rotating Parts Hazards

NEVER operate equipment with covers, or guards removed. Keep fingers, hands, hair and clothing away from all moving parts to prevent injury.



CAUTION

Equipment Damage Hazards

Other important messages are provided throughout this manual to help prevent damage to your portable generator, other property, or the surrounding environment.

CAUTION

Accidental Starting Hazards

ALWAYS place the power source, circuit breakers or **ON/OFF** switch in the **OFF** position, when the generator is not in use, unless connected to transfer switch.



CAUTION

Eye and Hearing Hazards

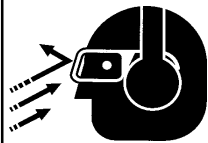

ALWAYS wear approved eye and hearing protection.

MQ GA-2.9R— RULES FOR SAFE OPERATION

DANGER

Read this manual!

Failure to follow instructions in this manual may lead to serious injury or even death! This equipment is to be operated by trained and qualified personnel only! This equipment is for industrial use only.

The following safety guidelines should always be used when operating the MQ GA-2.9R Portable Generator:

GENERAL SAFETY

■ **DO NOT** operate or service this equipment before reading this entire manual.



■ This equipment should not be operated by persons under 18 years of age.

■ **NEVER** operate this equipment without proper protective clothing, shatterproof glasses, steel-toed boots and other protective devices required by the job.



■ **NEVER** operate this equipment when not feeling well due to fatigue, illness or taking medicine.



■ **NEVER** operate this equipment under the influence of **drugs** or **alcohol**.



■ **ALWAYS** wear proper respiratory (mask), hearing and eye protection equipment when operating the generator.



■ Whenever necessary, replace nameplate, operation and safety decals when they become difficult read.

■ Manufacturer does not assume responsibility for any accident due to equipment modifications.

■ **NEVER** use accessories or attachments, which are not recommended by Multiquip for this equipment. Damage to the equipment and/or injury to user may result.

■ **NEVER** touch the hot exhaust manifold, muffler or cylinder. Allow these parts to cool before servicing engine or generator.

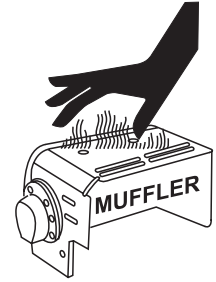

■ The engine section of this generator requires an adequate free flow of cooling air. **NEVER** operate the generator in any enclosed or narrow area where free flow of the air is restricted. If the air flow is restricted it will cause serious damage to the generator or engine and may cause injury to people. Remember the generator's engine gives off **DEADLY** carbon monoxide gas.

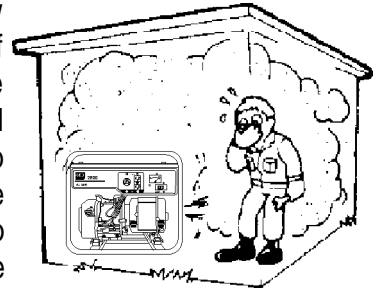

■ **ALWAYS** refuel in a well-ventilated area, away from sparks and open flames.

■ **ALWAYS** use extreme caution when working with **flammable** liquids. When refueling, **stop the engine** and allow it to cool. **DO NOT smoke** around or near the machine. Fire or explosion could result from fuel vapors, or if fuel is spilled on a hot engine.



■ **NEVER** operate the generator in an explosive atmosphere or near combustible materials. An explosion or fire could result causing severe **bodily harm or even death**.

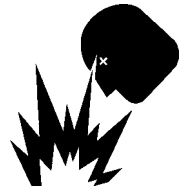

■ **NEVER** disconnect any "**emergency or safety devices**". These devices are intended for operator safety. Disconnection of these devices can cause severe injury, bodily harm or even death! Disconnection of any of these devices will void all warranties.

MQ GA-2.9R — RULES FOR SAFE OPERATION

- **ALWAYS** be sure the operator is familiar with proper safety precautions and operation techniques before using generator.
- **NEVER** leave the generator unattended, turn off engine when unattended.
- Unauthorized equipment modifications will void all warranties.
- **ALWAYS** ensure generator is on level ground before use.
- **DO NOT** place hands or fingers inside generator engine compartment when engine is running.
- **NEVER** run engine without air cleaner. Severe engine damage may occur.
- **NEVER** change or adjust the engine speed which has been set at the factory prior to shipping.

Power Cord Safety

- **NEVER** let power cables or cords *lay in water*.
- **NEVER** *stand in water* while AC power from the generator is being transfer to a load.
- **NEVER** use a defective or frayed power cable. Check the cable for cuts in the insulation.
- **NEVER** use a extension cord that is frayed or damaged where the insulation has been cut.
- **ALWAYS** make certain that proper power or extension cord has been selected for the job See Table 3.

Grounding Safety

- **ALWAYS** make sure that electrical circuits are properly *grounded* per the **National Electrical Code** (NEC) and local codes before operating generator. Severe *injury* or *death!* by electrocution can result from operating an ungrounded generator.
- **ALWAYS** make sure generator is properly grounded to a suitable earth ground (**GROUND ROD**). See installation in this manual.
- **NEVER** use *gas piping* as an electrical ground.

Maintenance Safety

- **NEVER** lubricate components or attempt service on a running machine.
- **High Temperatures** – Always stop engine and allow the engine to cool before adding fuel, oil or performing service and maintenance functions. Contact with **hot!** components can cause serious burns.
- Keep the machinery in proper running condition.
- Fix damage to the machine immediately and replace any broken parts immediately.
- **ALWAYS** replace any worn or damaged warning decals.
- **ALWAYS** store equipment properly when it is not being used. Equipment should be stored in a clean, dry location out of the reach of children and un-authorized personnel.
- The electrical voltage required to operate the generator can cause severe injury or even death through physical contact with live circuits. Turn all circuit breakers **OFF** before performing maintenance on the generator.
- Dispose of hazardous waste properly. Examples of potentially hazardous waste are used motor oil, fuel and fuel filters.
- **DO NOT** use food or plastic containers to dispose of hazardous waste.
- **DO NOT** pour waste, oil or fuel directly onto the ground, down a drain or into any water source.
- Removing the engine oil drain plug while the engine is hot will result in hot oil to gush out of the oil drain plug, therefore causing severe scalding to any persons in the general area of the generator.



DANGER-ELECTROCUTION HAZARDS

During operation of this generator, there exists the possibility of **electrocution, electrical shock or burn**, which can cause **severe bodily harm** or even **DEATH!**



To avoid these hazards:

NEVER use **damaged** or **worn** cables when connecting equipment to the generator. Make sure power connecting cables are securely connected to the generator's output receptacles, incorrect connections may cause damage to the generator and electrical shock.

NEVER grab or touch a live power cord with wet hands, the possibility exist of electrical shock, electrocution, and even **death!**

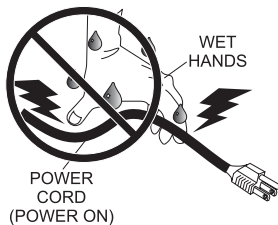

NEVER insert any objects into the output receptacles during operation. This is extremely dangerous. **ALWAYS** turn-off the generator and place all circuit breakers in the "OFF" position when contact with the output receptacles is required. There exist the possibility of **electrocution, electrical shock or burn, which can cause severe bodily harm or even death!**

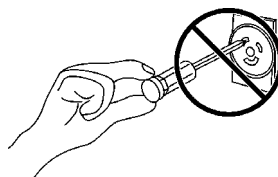

Backfeed to a utility system can cause **electrocution** and or property damage. **NEVER** connect the generator to a building's electrical system without a transfer switch or other approved device. All installations should be performed by a **licensed electrician** in accordance with all applicable laws and electrical codes. Failure to do so could result in electrical shock or burn causing serious injury or even death!

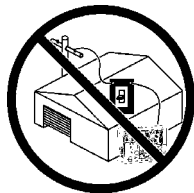

Emergencies

■ **ALWAYS** know the location of the nearest **fire extinguisher**.

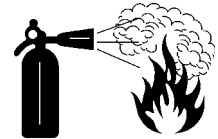

■ **ALWAYS** know the location of the nearest **first aid kit**.



■ In emergencies **always** know the location of the nearest phone or **keep a phone on the job site**. Also know the phone numbers of the nearest **ambulance, doctor** and **fire department**. This information will be invaluable in the case of an emergency.

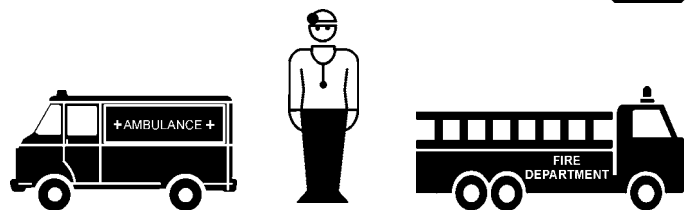

MQ GA-2.9R — OPERATION AND SAFETY DECALS

Machine Safety Decals

The MQ GA-2.9R portable generator is equipped with a number of safety decals (Figure 2). These decals are provided for operator safety and maintenance information. The illustration below shows these decals as they appear on the machine. Should any of these decals become unreadable, replacements can be obtained from your dealer.



P/N 8700611804

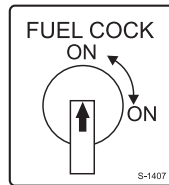

P/N 1630680104



CONTACT
MQ PARTS DEPT.



P/N 8700611904

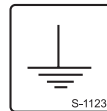

P/N 0800628504



P/N 35137



P/N 7900636004

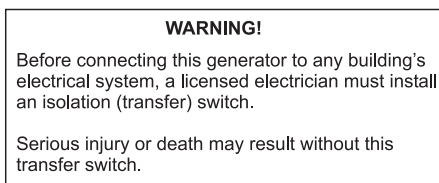

P/N 0820610404

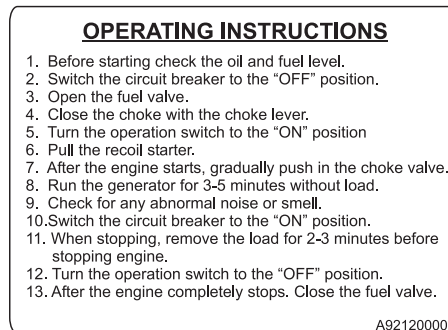

P/N A92120000



P/N A2561000103

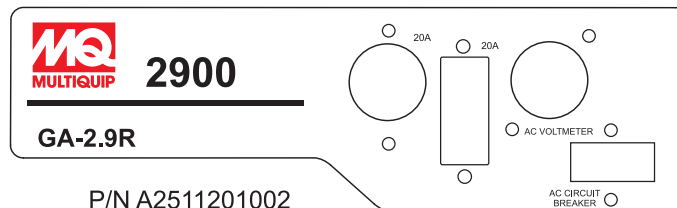

P/N A2511201002

Figure 2. Operation and Safety Decals

MQ GA-2.9R Familiarization

General Inspection Prior to Operation

This generator has been thoroughly inspected and accepted prior to shipment from the factory. However, be sure to check for damaged parts or components, or loose nuts and bolts, which could have become dislodged in transit.

The **MQ Model GA-2.9R** generator has been designed as a portable lightweight power source for 60 Hz (single-phase) vibrators, lighting facilities, power tools, submersible pumps and other industrial and construction machinery.

This generator is powered by a 5.7 HP **ROBIN** air-cooled gasoline engine. The alternator, a brushless revolving-field type, is permanently aligned to the engine through rigid coupling.

The generator is mounted on rubber vibration isolators that have a steel base backplate which is attached to the protective steel pipe carrying frame. The protective carrying frame is made of steel tubing and fully wraps around the generator to protect against damage.

This portable generator is supplied with a electrical **control panel**. The control panel includes items as listed below.

Control Panel

The generator control panel has the following components:

- NEMA 5-20R, GFCI duplex receptacle, (120V, 20 amps)
- NEMA L5-20R, twist-lock receptacle, (120V, 20 amps)
- Circuit breaker, single-pole, 22 amps
- AC Voltmeter
- Engine ON/OFF Switch
- Ground Terminal

Circuit Breaker

To protect the generator from an overload, a single-pole, 22 amp circuit breaker is provided on the control panel. Make sure to switch this circuit breaker to the "**OFF**" position prior to starting the engine.

Excitation System

The MQ GA-2.9R generator uses a magnet attached to a flywheel to produce AC voltage from a lamp coil beneath the flywheel. As the magnet passes the coil it produces approximately 19-22 AC volts.

This voltage (19-22 VAC) is then sent to the control box that contains three rectifying diodes:

- Excitation (diode 1)
- Battery (diode 2)
- Slow Down (diode 3)

The AC voltage will pass through the excitation diode that converts the voltage to DC power.

This DC power is then sent to the excitation windings housed within the main windings commonly called the "stator".

This voltage is then transferred into the rotor through induction. The rotor contains two diodes within it which rectify the DC voltage and send it out through the main windings, as AC voltage.

Engine

The four-cycle air-cooled **ROBIN** gasoline engine is designed to meet every performance requirement of this generator. Reference Table 1, for engine specifications.

Figure 3 shows the basic controls and indicators for the MQ GA-2.9R generator.

WARNING

Before connecting this generator to any building's electrical system, a licensed electrician must install an **isolation** (transfer) **switch**.

Serious injury or death may result without this transfer switch. Please note that the transfer switch can only be configured with generators that have electric start capability. Transfer switch should not be used with recoil-start type generators.

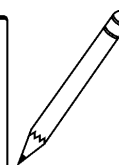
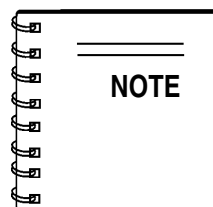

In keeping with **Multiquip's** policy of constantly improving its products, the specifications quoted herein are subject to change without prior notice.

Single Phase Load

Always be sure to check the nameplate on the generator and equipment to insure the wattage, amperage and frequency requirements are satisfactorily supplied by the generator for operating the equipment.

Generally, the wattage listed on the nameplate of the equipment is its rated output. Equipment may require 130—150% more wattage than the rating on the nameplate, as the wattage is influenced by the efficiency, power factor and starting system of the equipment.

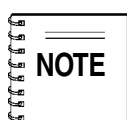

If wattage is not given on the equipment's name plate, approximate wattage may be determined by multiplying nameplate voltage by the nameplate amperage.

$$\text{WATTS} = \text{VOLTAGE} \times \text{AMPERAGE}$$

The power factor of this generator is 1.0 See Table 2 below when connecting loads.

Table 2. Power Factor By Load

| Type Of Load | Power Factor |
|---|--------------|
| Single-phase induction motors | 0.4 - 0.75 |
| Electric heaters, incandescent lamps | 1.0 |
| Fluorescent lamps, mercury lamps | 0.4 - 0.9 |
| Electronic devices, communication equipment | 1.0 |
| Common power tools | 0.8 |

To determine the running wattage for your load, multiply the running wattage as indicated by steps 1, 2, and 3 below:

1. **INCANDESCENT LOADS**
Lights, heaters and similar appliances.
Total the running wattage and multiply by 1.
Example:
29 light bulbs @ 100W each = 2.9 KW
use a 3 KW generator.
2. **SMALL MOTORS**
Drills and other small power tools.
Total the running wattage and multiply by 2.
Example:
A 1 inch drill runs at 1 KW
use a 2 KW generator.
3. **LARGE MOTORS**
Submersible pumps, table saws etc.
Total the running wattage and multiply by 3.
Example:
A conveyor belt runs at 8 KW
use a 24 KW generator.

CAUTION

Motors and motor-driven equipment draw much greater current for starting than during operation. **Always** use an adequate size **extension cable** which can carry the required load.

Extension Cables

When electric power is to be provided to various tools or loads at some **distance** from the generator, extension cords are normally used. **Cables should be sized to allow for distance in length and amperage so that the voltage drop between the generator and point of use (load) is held to a minimum.** Use the cable selection chart (Table 3) as a guide for selecting proper cable size.

MQ GA-2.9R — CONTROLS AND INDICATORS

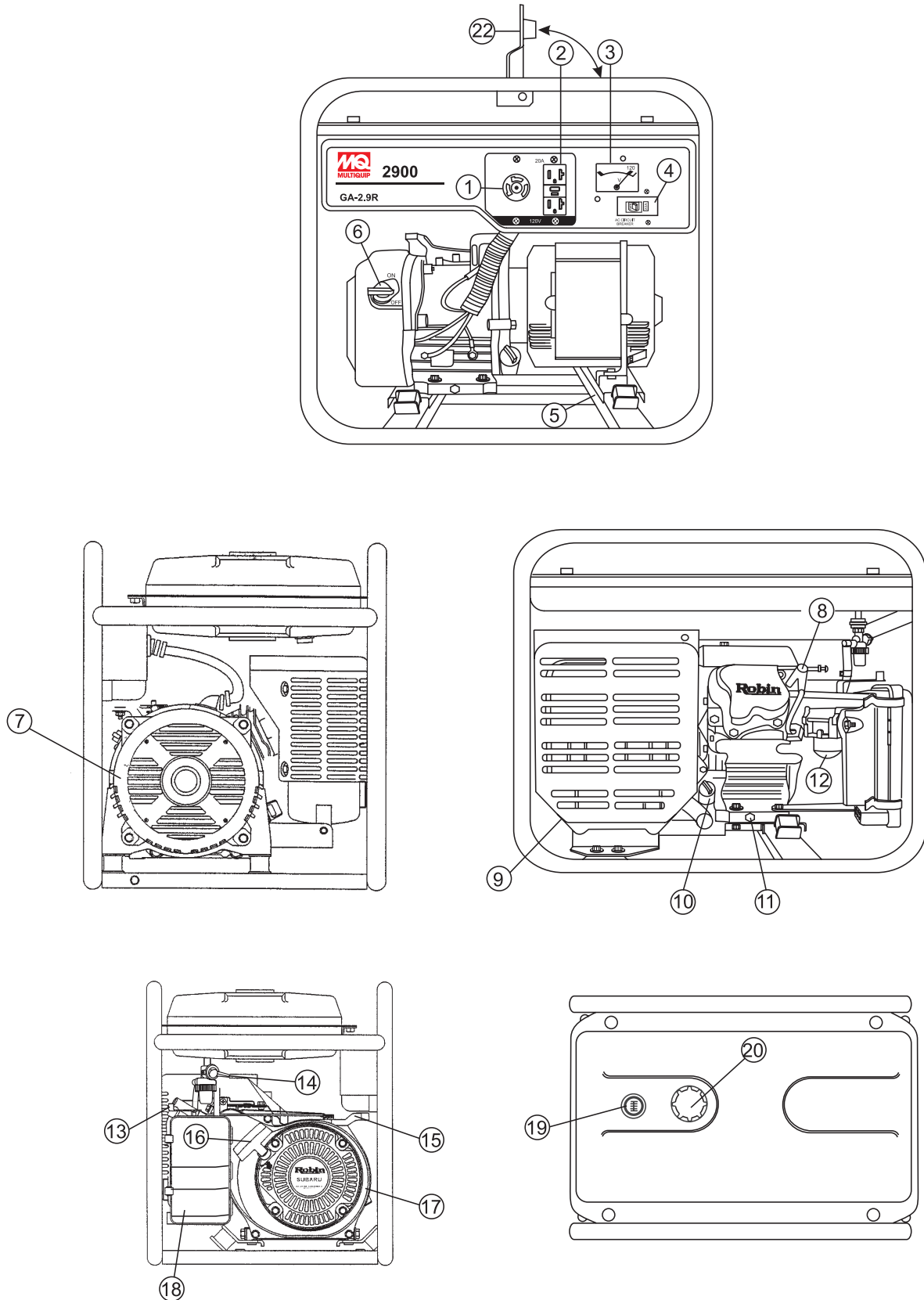
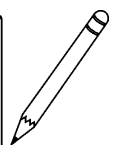
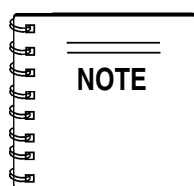

Figure 2. Generator Controls and Components

MQ GA-2.9R — CONTROLS AND INDICATORS

1. **120V Output Receptacle** – This NEMA L5-20R twist-lock receptacle will provide 120V, 20 amps, 60 Hz.
2. **GFCI Receptacle** – This receptacle will provide 120V at all times.
3. **AC-Voltmeter** – This voltmeter indicates (with a mark) the rated 60 Hz, single phase output voltage. In addition the voltmeter can also be used as a diagnostic tool. If the voltmeter indicator (needle) is below the rated voltage, engine problems may exist (low/high RPM's). To prevent damage to the generator or power tools turn the generator **OFF** and consult your authorized **MQ** service dealer.
4. **Main Circuit Breaker** – This single-pole 22 amp breaker protects the generator from short circuiting or overloading. When starting the generator **always** have the circuit breaker placed in the "OFF" position.
5. **Ground** – This ground connection point should be connect to a good earth ground (ground rod).



This **ROBIN** engine is equipped with a low oil shutdown capability. A built in sensor will automatically turn off the engine should the oil level fall below a safe operating condition.

Make sure the generator is placed on level ground. Placing the generator on level ground will ensure that the low oil sensor will function properly.

6. **Operation/ON-OFF Switches** – Place engine **ON/OFF** switch in the "ON" position for normal operation. To turn-off the generator place switch in the "OFF" position.
7. **Generator Housing** – Contains the rotor, rectifier field coil assembly, armature, bearings and other components that make up generator assembly.
8. **Spark Plug** – Provides spark to the ignition system. Set spark plug gap to 0.6 - 0.7 mm (0.024 - 0.028 inch). Clean spark plug once a week.
9. **Muffler/Heat Shield** – Used to reduce noise and emissions. **NEVER** touch this **heat shield** when the generator is in use. Always allow time for the generator to cool down before performing maintenance.
10. **Oil Dipstick/ Filler Cap**– Remove the filler cap dipstick when checking the engine oil level. Add engine oil through this filler port. See Table 4 for recommended type engine oil.

WARNING

ALWAYS allow time for the generator to **cool down** before performing maintenance.



11. **Oil Drain Plug** – Remove this plug to drain engine oil from the crankcase.
12. **Carburetor Fuel Cup** – Inspect the fuel cup weekly for water and dirt. Clean as referenced in the maintenance section of this manual.
13. **Choke Lever** – Used for starting the engine. **Close** the choke lever when starting a cold engine or in cold weather conditions. The choke enriches the fuel mixture. **Open** the choke lever if starting a warm engine or in warm weather conditions.
14. **Fuel Cock Lever** – Turn this lever **downward to start** (down) the flow of fuel to the carburetor. Turn **upward to stop** (up) the flow of fuel.
15. **Throttle Lever** – Used to adjust engine RPM speed. This unit is set at the factory and is not adjustable.
16. **Recoil Starter (Pull Rope)** – Used for manual-starting of the engine. Pull the starter grip until resistance is felt, then pull briskly and smoothly.
17. **Engine** – This generator uses a 5.1 HP **ROBIN** air-cooled, 4-stroke, single cylinder, overhead camshaft gasoline engine. Engine uses unleaded fuel.
18. **Air Cleaner** – Prevents dirt and other debris from entering the fuel system. Remove wing-nut on top of air filter canister to gain access to filter element. **NEVER** run the engine without an air cleaner.
19. **Fuel Gauge** – Read this gauge to determine when fuel is **low**.
20. **Fuel Gauge/Tank** – Remove this cap to add unleaded gasoline to the fuel tank. **Replenish** with **clean unleaded** gasoline. Make sure cap is tightened securely. **DO NOT** over fill. Fuel tank capacity is 3.17 gallons (12 liters).
21. **Lifting Bail Eye** – Attach a rope or chain to this lifting eye when lifting of the generator is required. Never stand underneath the generator while it is being lifted. Place lifting eye in down position when not in use.

MQ GA-2.9R — GENERATOR REFUELING

DANGER

Adding fuel to the tank should be done only when the engine is stopped and has had an opportunity to cool down. In the event of a fuel spill, **DO NOT** attempt to start the engine until the fuel residue has been completely wiped up, and the area surrounding the engine is dry. If generator is placed in a truck bed with a plastic liner, **REMOVE** generator from truck bed and place on ground (Figure 4) to refuel. This possibility exist of *fire* or *explosion* due to static electricity.

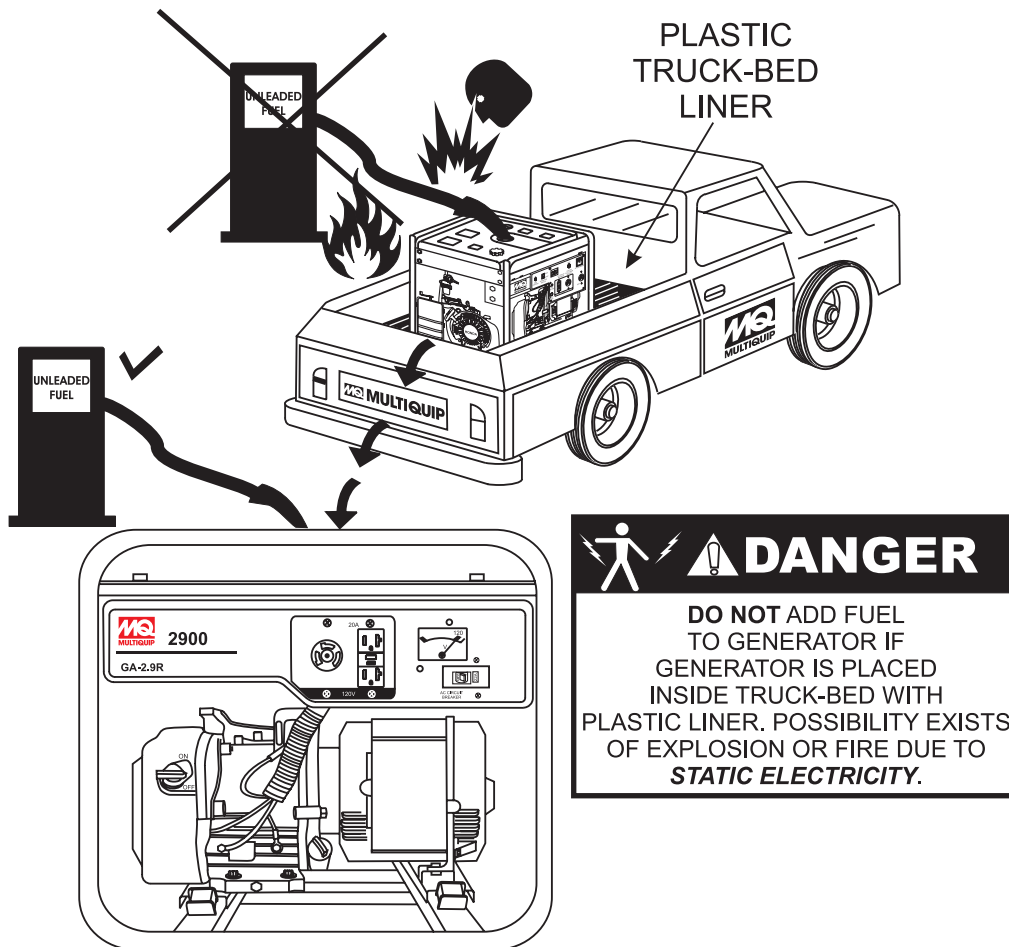



Figure 4. Generator Refueling

Outdoor Installation

Install the generator in a area that is free of **debris**, **bystanders**, and **overhead obstructions**. Make sure the generator is on secure level ground so that it cannot slide or shift around. Also install the generator in a manner so that the exhaust will not be discharged in the direction of nearby homes.

The installation site must be relatively free from moisture and dust. All electrical equipment should be protected from excessive moisture. Failure to do will result in deterioration of the insulation and will result in short circuits and grounding.

Foreign materials such as dust, sand, lint and abrasive materials have a tendency to cause excessive wear to engine and alternator parts.

| | |
|---|--|
|  CAUTION |  |
| Pay close attention to ventilation when operating the generator inside tunnels and caves. The engine exhaust contains noxious elements. | |

Mounting

The generator should always be mounted on a flat level surface to isolate vibration of the generator when it is running. **DO NOT** place the generator on slopes, the possibility exists that the generator could slide.

Indoor Installation

Exhaust gases from gasoline engines are extremely poisonous. Whenever an engine is installed indoors the exhaust fumes must be vented to the outside. The engine should be installed at least two feet from any outside wall. Using an exhaust pipe which is too long or too small can cause excessive back pressure which will cause the engine to heat excessively and possibly burn the valves.

Eliminate the danger of deadly carbon monoxide gas. Remember that exhaust fumes from any gasoline engine are very poisonous if discharged in a closed room, but harmless if allowed to mix with the outside air. If the generator is installed indoors, you must make provisions for venting the engine exhaust to the outside of the building.

Generator Grounding

To guard against electrical shock and possible damage to the equipment, it is important to provide a good **EARTH** ground. Always use the ground terminal on the generator to ground the generator.

Article 250 (Grounding) of the National Electrical Code (NEC) provides guide lines for proper grounding and specifies that the cable ground shall be connected to the grounding system of the building as close to the point of cable entry as practical.

NEC articles 250-64(b) and 250-66 set the following grounding requirements:

1. Use one of the following wire types to connect the generator to earth ground.
 - a. Copper - 10 AWG (5.3 mm²) or larger.
 - b. Aluminum - 8 AWG (8.4 mm²) or larger.
2. When grounding the generator (Figure 3) connect the ground cable between the lock washer and the nut on the generator and tighten the nut fully. Connect the other end of the ground cable to earth ground.
3. NEC article 250-52(c) specifies that the earth ground rod should be buried a minimum of 8 ft. into the ground.

Connecting the Ground

The nut and ground terminal on the generator should always be used to connect the generator to a suitable ground. The ground cable should be #8 size wire minimum.

At the generator, connect the terminal of the ground cable between the lock washer and the nut (Figure 5) and tighten the nut fully. Connect the other end of the ground cable to a suitable earth ground (ground rod).

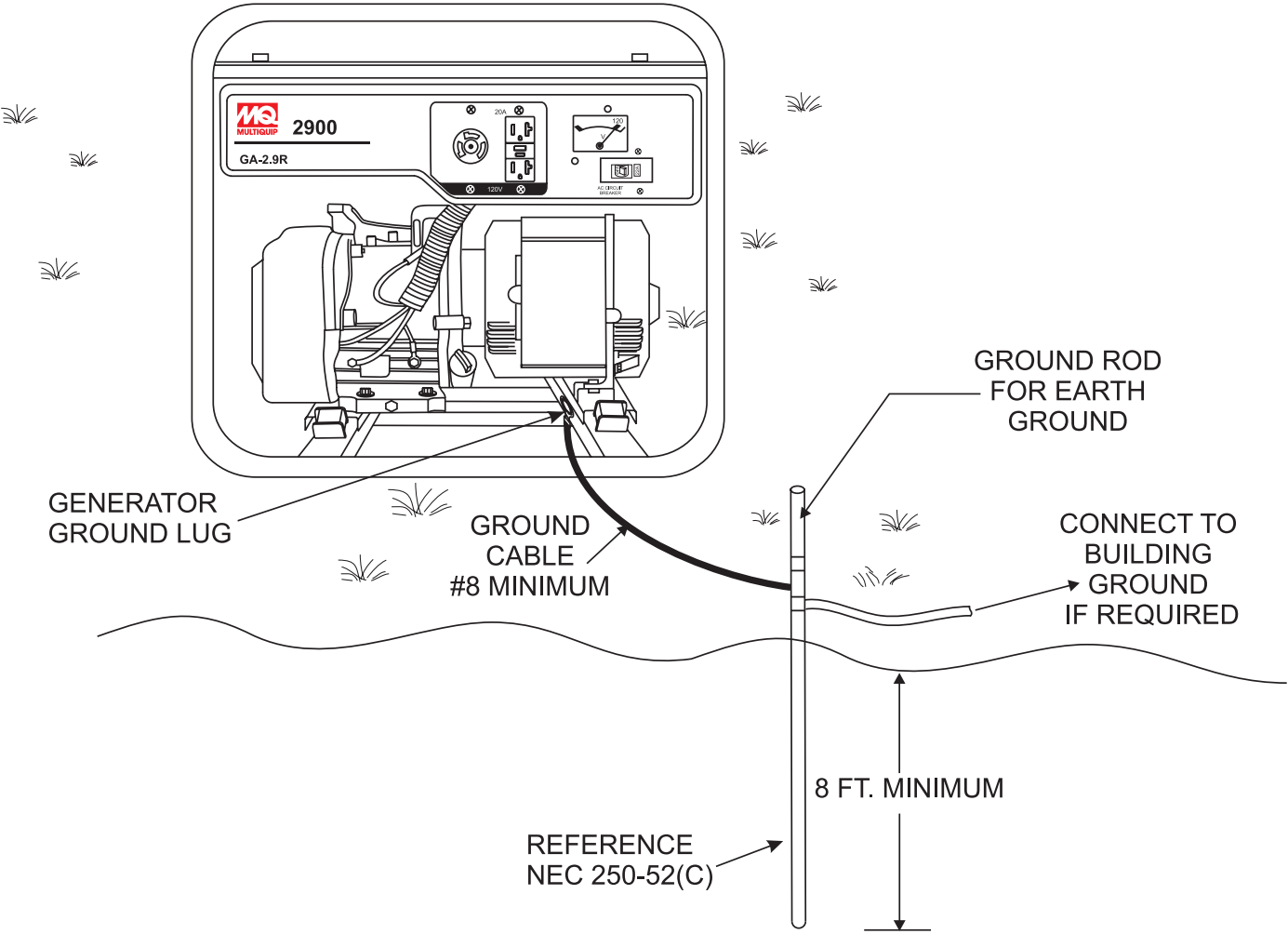

Figure 5. Generator Grounding

General Inspection Prior to Operation

Ground Power Tools

When using power tools or electrical equipment requiring AC power from the generator, make sure connecting (power tool) cable (Figure 6) has a ground as shown in Figure.

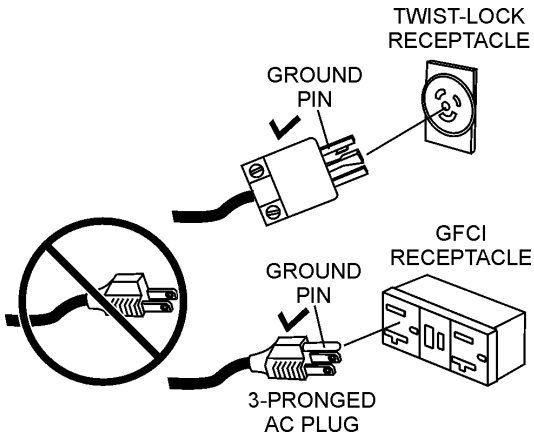
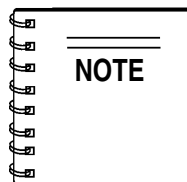

Figure 6. Ground Cables/Plugs

Extension Cable

When electric power is to be provided to various tools or loads at some distance from the generator, extension cords are normally used. Cables should be sized to allow for distance in length and amperage so that the voltage drop between the generator and point of use (load) is held to a minimum. Use the cable selection chart (Table 3) as a guide for selecting proper cable size.



Never! use power tools or equipment that do not have a ground capability, the possibility exists **of electrocution, electrical shock or burn**, which can cause **severe bodily harm** or even **DEATH!**

Main Circuit Breaker

To protect the generator from an overload always place the main circuit breaker in the "OFF" position prior to starting the engine.

Table 3. Cable Selection (60 Hz, Single Phase Operation)

| Current in Amperes | Load In Watts | Maximum Allowable Cable Length | | | |
|--------------------|---------------|--------------------------------|----------|----------|----------|
| | At 120 Volts | #10 Wire | #12 Wire | #14 Wire | #16 Wire |
| 2.5 | 300 | 1000 ft. | 600 ft. | 375 ft. | 250 ft. |
| 5 | 600 | 500 ft. | 300 ft. | 200 ft. | 125 ft. |
| 7.5 | 900 | 350 ft. | 200 ft. | 125 ft. | 100 ft. |
| 10 | 1200 | 250 ft. | 150 ft. | 100 ft. | |
| 15 | 1800 | 150 ft. | 100 ft. | 65 ft. | |
| 20 | 2400 | 125 ft. | 75 ft. | 50 ft. | |

CAUTION: Equipment damage can result from low voltage.

MQ GA-2.9R — PRE-INSPECTION (ENGINE)

CAUTION

NEVER operate the generator in a confined area or enclosed area structure that does not provide ample **free flow of air**.



ALWAYS wear approved eye and hearing protection before operating the generator.

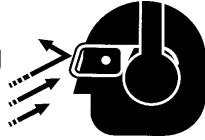

Before Starting

1. Read safety instructions at the beginning of manual.
2. Clean the generator, removing dirt and dust, particularly the engine cooling air inlet, carburetor and air cleaner.
3. Check the air filter for dirt and dust. If air filter is dirty, replace air filter with a new one as required.
4. Check carburetor for external dirt and dust. Clean with dry compressed air.
5. Check fastening nuts and bolts for tightness.



Engine Oil Check

1. To check the engine oil level, place the generator on secure level ground with the engine stopped.
2. Remove the filler dipstick from the engine oil filler hole (Figure 7) and wipe clean.

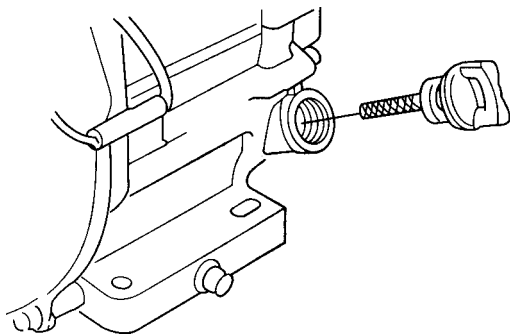

Figure 7. Engine Oil Dipstick (Removal)

3. Insert and remove the dipstick without screwing it into the filler neck. Check the oil level shown on the dipstick.
4. If the oil level is low (Figure 8), fill to the edge of the oil filler hole with the recommended oil type (Table 4). Maximum oil capacity is .63 quarts (0.6 liters)

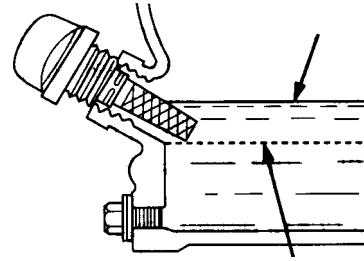

Figure 8. Engine Oil Dipstick (Oil Level)

Table 4. Oil Type

| Season | Temperature | Oil Type |
|-------------|----------------|---------------|
| Summer | 25°C or Higher | SAE 10W-30 |
| Spring/Fall | 25°C~10°C | SAE 10W-30/20 |
| Winter | 0°C or Lower | SAE 10W-10 |

DANGER EXPLOSIVE FUEL

Motor fuels are highly flammable and can be dangerous if mishandled. **DO NOT** smoke while refueling. **DO NOT** attempt to refuel the generator if the engine is **hot!**, **running or in the dark**.



Fuel Check

1. Close the fuel cock before filling the fuel tank.
2. Remove the fuel cap located on top of fuel tank.
3. Read the fuel gauge located on top of the fuel tank (Figure 9) to determine if the fuel level is low. If fuel is low, replenish with **clean unleaded fuel**.

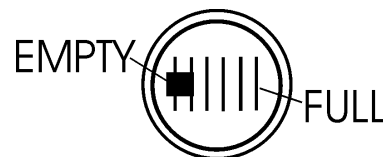

Figure 9. Fuel Gauge

4. When refueling, be sure to use a strainer for filtration. **DO NOT** top-off fuel. **DO NOT** fill the tank beyond capacity. Wipe up any spilled fuel **immediately!**

MQ GA-2.9R — INITIAL START-UP (ENGINE)

CAUTION

DO NOT attempt to operate this generator until the Safety, General Information and Inspection sections of this manual have been **read and thoroughly understood**.



This section is intended to assist the operator with the **initial start-up** of the trash generator. It is extremely important that this section be read carefully before attempting to use the generator in the field.

Before Starting the Engine

1. Be sure to **disconnect all electrical loads** from the generator prior to starting the engine.
2. **NEVER start** the engine with the **main circuit breaker** in the "ON" position. Place the main circuit breaker (Figure 10) in the **OFF** position.

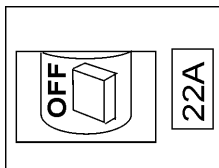

Figure 10. Main Breaker (OFF Position)

Starting the Engine

1. Place the engine **fuel valve lever** (Figure 11) to the "ON" position."

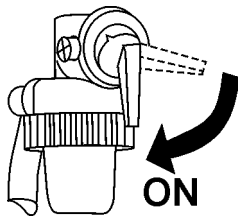

Figure 11. Engine Fuel Valve Lever (ON Position)

2. Place the **choke lever** (Figure 12) in the "CLOSED" position if starting a **cold** engine.

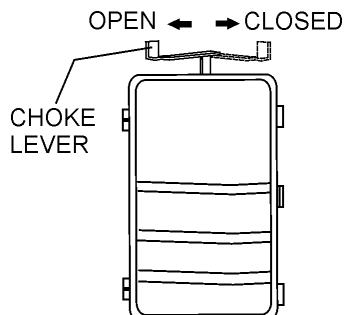

Figure 12. Choke Lever

3. Place the **choke lever** (Figure 12) in the "OPEN" position if starting a **warm engine** or the **temperature is warm**.
4. Place the **engine ON/OFF switch** (Figure 13) in the "ON" position.

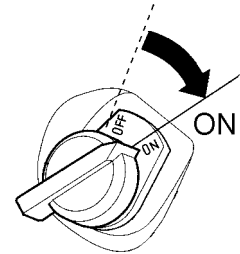

Figure 13. Engine ON/OFF Switch (ON)

5. Grasp the starter grip (Figure 14) and slowly pull it out. The resistance becomes the hardest at a certain position, corresponding to the compression point. Pull the starter grip briskly and smoothly for starting.

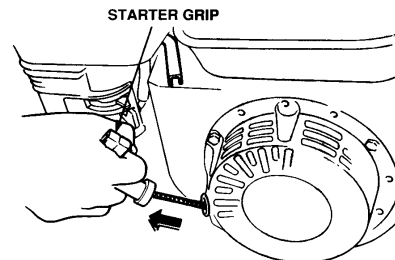

Figure 14. Starter Grip

CAUTION

DO NOT pull the starter rope all the way to the end.
DO NOT release the starter knob after pulling. Allow it to rewind as soon as possible.

MQ GA-2.9R— INITIAL START-UP ENGINE/OPERATION

- If the engine has started, slowly return the choke lever (Figure 12) to the **"OPEN"** position. If the engine has not started repeat steps 1 through 5.
- Before the generator is placed into operation, run the engine for 3-5 minutes. Check for abnormal smells, fuel leaks, and noises that would associate with loose components.
- Refer to the AC voltmeter (Figure 15) on the control box. The voltage indicated on the voltmeter should be 120 VAC with no load applied.

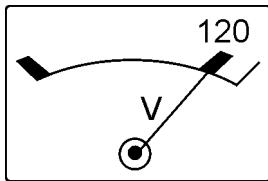

Figure 15. AC Voltmeter (120 VAC)

- If desired, verify with a voltmeter (Figure 16) that 120 VAC is present at the GFCI duplex receptacle and the 120V twist-lock receptacle.

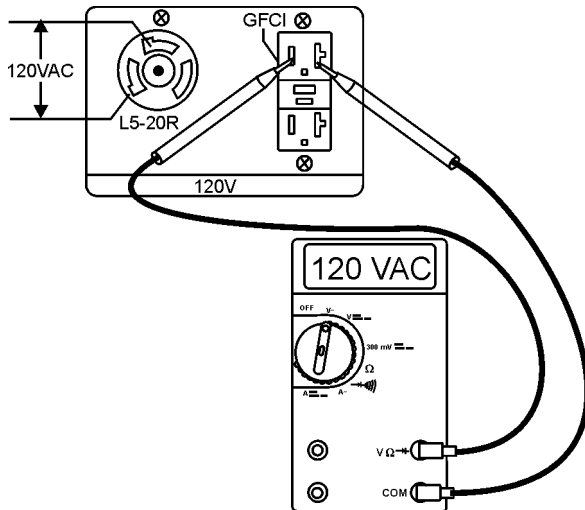

Figure 16. 120 VAC GFCI Receptacle

Connecting the Load

- Connect the load to the output receptacles.
- Place the main circuit breaker (Figure 17) in the **ON** position.

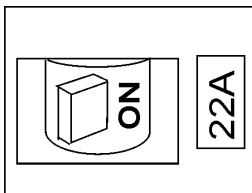

Figure 17. Main Circuit Breaker (ON)

Stopping The Engine

Normal Shutdown

- Place the **main circuit breaker** (Figure 10) in the **OFF** position.
- Remove the load from the generator, and let the engine run at idle for 3-5 minutes with the idle control switch in the **ON** position (Up)
- Place the **engine ON/OFF switch** (Figure 18) in the **"OFF"** position.

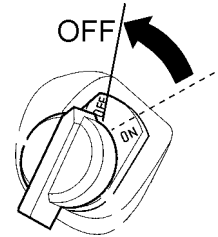

Figure 18. Engine ON/OFF Switch (OFF)

- Place the engine **fuel valve lever** (Figure 19) to the **"OFF"** position."

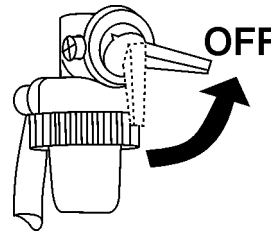

Figure 19. Engine Fuel Valve Lever (OFF Position)

Emergency Shutdown

- Place the **engine ON/OFF switch** (Figure 18) in the **"OFF"** position.

MQ GA-2.9R — PREPARATION FOR LONG -TERM STORAGE

Generator Storage

For storage of the generating set for over 30 days, the following is required:

- Drain the fuel tank completely, or add STA-BIL to the fuel.
- Run the engine until the gasoline in the carburetor is completely consumed.
- Completely drain the oil from the crankcase and refill with fresh oil.
- Remove the spark plug, pour 2 or 3 cc of SAE 30 oil into the cylinder and crank slowly to distribute the oil.
- Slowly rotate the engine a few times with the starter Rope and install a new plug.
- Pull out the starter rope slowly and stop at the compression point.
- Clean all external parts of the generating set with a cloth.
- Cover the generating set and store in a clean, dry place.

MQ GA-2.9R — MAINTENANCE (ENGINE)

Use Table 5 as a general maintenance guideline when servicing your engine. For more detail engine maintenance information, refer to the engine owner's manual supplied with your engine.

Table 5. Engine Maintenance Schedule

| DESCRIPTION (3) | OPERATION | BEFORE | FIRST MONTH OR 10 HRS. | EVERY 3 MONTHS OR 25 HRS. | EVERY 6 MONTHS OR 50 HRS. | EVERY YEAR OR 100 HRS. | EVERY 2 YEARS OR 200 HRS. |
|------------------|-------------------------|--|------------------------|---------------------------|---------------------------|------------------------|---------------------------|
| Engine Oil | CHECK | X | | | | | |
| | CHANGE | | X | | | | |
| Air Cleaner | CHECK | X | | | | | |
| | CHANGE | | | X (1) | | | |
| All Nuts & Bolts | Re-tighten If Necessary | X | | | | | |
| Spark Plug | CHECK-CLEAN | | | | X | | |
| | REPLACE | | | | | | X |
| Cooling Fins | CHECK | | | | X | | |
| Spark Arrester | CLEAN | | | | | X | |
| Fuel Tank | CLEAN | | | | | X | |
| Fuel Filter | CHECK | | | | | X | |
| Idle Speed | CHECK-ADJUST | | | | | X (2) | |
| Valve Clearance | CHECK-ADJUST | | | | | | X (2) |
| Fuel lines | CHECK | Every 2 years (replace if necessary) (2) | | | | | |

(1) Service more frequently when used in **DUSTY** areas.

(2) These items should be serviced by your service dealer, unless you have the proper tools and are mechanically proficient. Refer to the ROBIN Shop Manual for service procedures.

(3) For commercial use, log hours of operation to determine proper maintenance intervals.

Maintenance

Perform the scheduled maintenance procedures as defined by Table 6 and below:

DAILY

- Thoroughly remove dirt and oil from the engine and control area. Clean or replace the air cleaner elements as necessary. Check and retighten all fasteners as necessary. Check the gearbox for oil leaks. Repair or replace as needed.

WEEKLY

- Remove the fuel filter cap and clean the inside of the fuel tank.
- Remove or clean the filter at the bottom of the tank.
- Remove and clean the spark plug (Figure 20), then adjust the spark gap to 0.024 ~0.028 inch (0.6~0.7 mm). This unit has electronic ignition, which requires no adjustments.

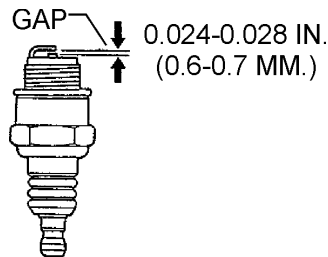

Figure 20. Spark Plug Gap

ENGINE OIL

- Drain the engine oil when the oil is **warm** as shown in Figure 21.
- Remove the oil drain bolt and sealing washer and allow the oil to drain into a suitable container.
- Replace engine oil with recommended type oil as listed in Table 4. For engine oil capacity, see Table 1 (engine specifications). **DO NOT** overfill.
- Install drain bolt with sealing washer and tighten securely.

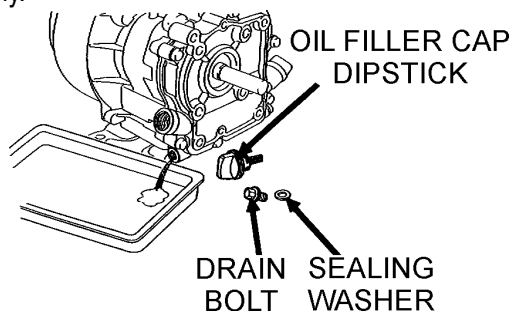
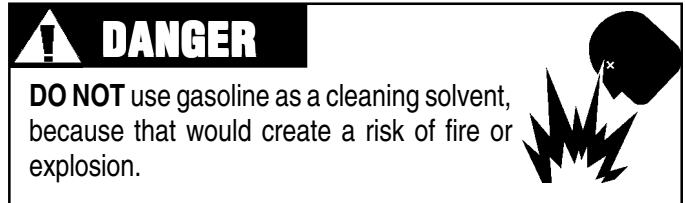

Figure 21. Engine Oil (Draining)

Cleaning the Fuel Strainer

Clean the fuel strainer if it contains dust or water. Remove dust or water in the strainer cap and wash it in gasoline. Securely fasten the fuel strainer cap so that fuel will not leak. Check the fuel strainer every 200 hours of operation or once a month.



ENGINE AIR CLEANER

- Remove the air cleaner cover and foam filter element as shown in Figure 22.
- Tap the paper filter element (Figure 22) several times on a hard surface to remove dirt, or blow compressed air [not exceeding 30 psi (207 kPa, 2.1 kgf/cm²)] through the filter element from the air cleaner case side. **NEVER** brush off dirt. Brushing will force dirt into the fibers. Replace the paper filter element if it is excessively dirty.

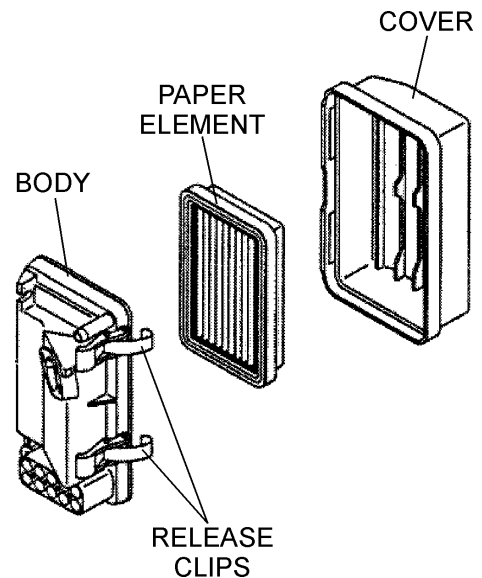
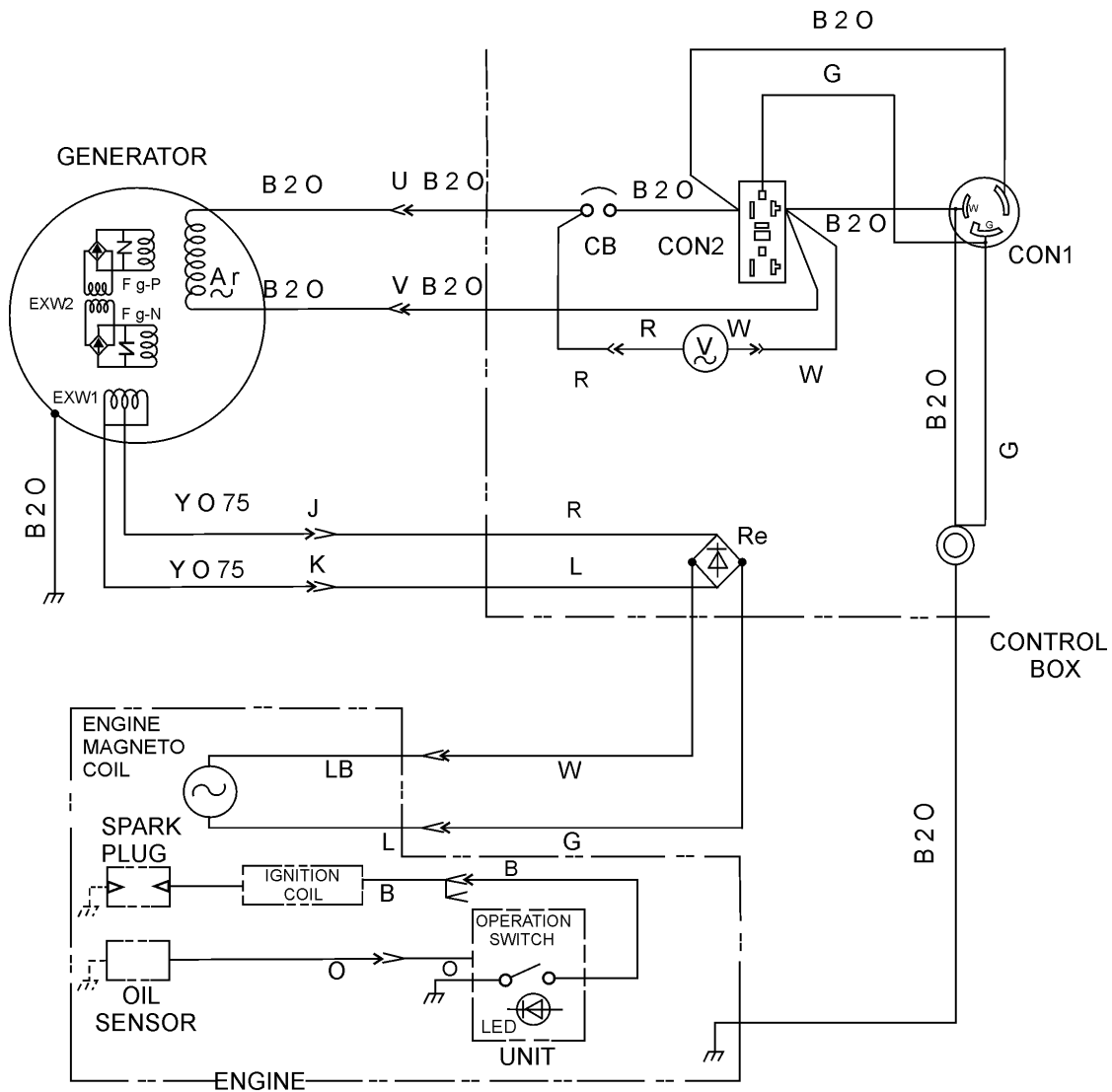

Figure 22. Engine Air Cleaner

MQ GA-2.9R — WIRING DIAGRAM



| COLOR CODE | | | |
|------------|--------|------------|-------------|
| WIRE COLOR | | WIRE COLOR | |
| B | BLACK | R | RED |
| L | BLUE | W | WHITE |
| BR | BROWN | Y | YELLOW |
| G | GREEN | LB | LIGHT BLUE |
| GR | GRAY | LG | LIGHT GREEN |
| V | VIOLET | O | ORANGE |
| P | PINK | | |

| SYMBOL | DESIGNATION |
|---------|-----------------------------|
| Ar | ARMATURE WINDING |
| EXW1 | EXCITATION WINDING |
| EXW2 | EXCITATION WINDING |
| Fg-P, N | FIELD WINDING |
| Re | RECTIFIER |
| CB | CIRCUIT BREAKER 22A |
| V | AC VOLTMETER 120V |
| CON 1 | RECEPTACLE L5-20R 20A, 125V |
| CON 2 | RECEPTACLE 5-20R 20A, 125V |

Figure 23. Generator/Engine Wiring Diagram

MQ GA-2.9R — TROUBLESHOOTING (ENGINE)

Practically all breakdowns can be prevented by proper handling and maintenance inspections, but in the event of a breakdown, please take a remedial action following the

diagnosis based on the Engine Troubleshooting (Table 6) information shown below and on the preceding page. If the problem cannot be remedied, please leave the unit just as it is and consult our company's business office or service plant.

TABLE 6. ENGINE TROUBLESHOOTING

| SYMPTOM | POSSIBLE PROBLEM | SOLUTION |
|--|---|---|
| Poor starting | Inspect carburetor to see if fuel is reaching it? | Check fuel line |
| | No Fuel? | Add Fuel |
| | Water in fuel tank? | Flush or replace fuel tank. |
| | Fuel filter clogged? | Replace fuel filter |
| | Stuck carburetor? | Check float mechanism. |
| | Spark plug is red? | Spark plug is fouled. Check transistor ignition unit. |
| | Spark plug is blue-white? | Insufficient compression, injected air leaking. Carburetor jets are clogged (overflow). |
| | No spark present at tip of spark plug? | Transistor ignition unit broken, high voltage cord cracked or broken. Start/Stop switch broken. Replace spark plug if fouled. |
| | No oil? | Add oil as required. |
| | Oil pressure alarm lamp blinks upon starting? | Check Automatic shutdown circuit "oil sensor". |
| Insufficient power output "no compression" | Engine will not turn over? | Replace cylinder and piston and if necessary axel joint. |
| | Cylinder head connecting bolts loose? | Tighten cylinder head connecting bolts. |
| | Cylinder head gasket damaged? | Replace cylinder head gasket. |
| | Malfuction of valve seat? | Re-seat valves. |
| | Spark plug is loose? | Replace spark plug. |
| | Worn piston rings? | Replace piston rings. |
| Insufficient power output "compression" | Malfuction in air-cleaner system, air filter clogged? | Clean or replace air filter. |
| | Air leaking in from interface between carburetor and cylinder head? | Tighten bolts between carburetor and cylinder head. Replace cylinder head gasket. |
| | Malfuction in fuel system? | Clean or replace fuel filter. Clean or replace carburetor. Check carburetor float. |

MQ GA-2.9R — TROUBLESHOOTING (ENGINE)

TABLE 6. ENGINE TROUBLESHOOTING (CONTINUED)

| SYMPTOM | POSSIBLE PROBLEM | SOLUTION |
|--|---|---|
| Insufficient power output "compression" and overheats | Malfunction in blower? | Check or replace blower. |
| | Air in-take filter clogged? | Clean or replace air in-take filter. |
| Burns to much fuel | Over accumulation of exhaust products? | Clean and check valves. Check muffler, replace if necessary. |
| | Wrong spark plug? | Replace spark plug with manufactures suggested type spark plug. |
| Exhaust color is continously "WHITE" | Lubricating oil is wrong viscosity? | Replace lubricating oil with correct viscosity. |
| | Worn rings? | Replace rings |
| Exhaust color is continously "BLACK" | Air cleanner clogged? | Clean or replace air cleaner. |
| | Choke valve has not been set to the correct position? | Adjust choke valve to the correct position. |
| | Carburetor defective, seal on carburetor broken? | Replace carburetor or seal. |
| | Poor carburetor adjustment "engine runs too rich?" | Adjust carburetor. |

MQ GA-2.9R — TROUBLESHOOTING (GENERATOR)

Practically all generator breakdowns can be prevented by proper handling and maintenance inspections, but in the event of a breakdown, please take a remedial action following the

diagnosis based on the Generator Troubleshooting (Table 7) information shown below and on the preceding page. If the problem cannot be remedied, please leave the unit just as it is and consult our company's business office or service plant.

TABLE 7. GENERATOR TROUBLESHOOTING

| SYMPTOM | POSSIBLE PROBLEM | SOLUTION |
|---|--|--|
| Low voltage | Engine speed too low? | Raise engine speed to rated RPM. |
| Low voltage. Engine speed normal 3650 RPM (unloaded), 2500 RPM (idle) | AC voltmeter not working? | Replace AC voltmeter. |
| | Control box internal wiring malfunction? | Check control box wiring. |
| | Defective ignition coil? | Check red and green ignition wires. Replace ignition wires if necessary. |
| | Rotor winding malfunction? | Check or replace rotor. |
| | Stator winding malfunction? | Check or replace stator. |
| | Breaker malfunction? | Check or replace CB1. |
| Voltage output too high. | Engine speed too high? | Lower engine speed to rated RPM. |
| Voltage output too high. Engine speed normal 3650 RPM (unloaded), 2500 RPM (idle) | Control box internal wiring malfunction | Check control box wiring. |
| Circuit breaker will not turn on "NO LOAD" | Defective circuit breaker? | Replace circuit breaker. |
| Circuit breaker will turn on "LOADED" but trips immediately. | Overload? | Reduce load or replace breaker. |
| | Load circuit is shorted? | Check load circuit for short. |
| Does not accelerate from low to high "NO LOAD" | Stuck solenoid? | Check solenoid. |
| Does not accelerate from low to high "LOAD ACTIVE" | Control box internal wiring defective? | Check control box wiring. |
| Does not decelerate no "VOLTAGE OUTPUT". | Defective rotor windings? | Check or replace rotor. |
| | Defective solenoid? | Check or replace solenoid. |
| | Defective idle control device? | Check or replace idle control device. |
| | Defective solenoid? | Check or replace idle control device. |
| Does not decelerate but has "VOLTAGE OUTPUT". | Control box wiring malfunction? | Check control box wiring, replace any defective components. |
| | Defective solenoid? | Check or replace solenoid. |
| | Idle control device malfunction? | Check or replace idle control device. |

MQ GA-2.9R — EXPLANATION OF CODE IN REMARKS COLUMN

How to read the marks and remarks used in this parts book.

Items Found In the “Remarks” Column

Serial Numbers-Where indicated, this indicates a serial number range (inclusive) where a particular part is used.

Model Number-Where indicated, this shows that the corresponding part is utilized only with this specific model number or model number variant.

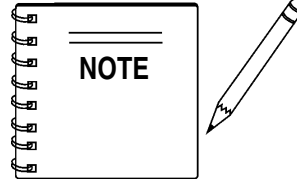

The contents of this catalog are subject to change without notice.

Items Found In the “Items Number” Column

All parts with same symbol in the number column, *, #, +, %, or <, belong to the same assembly or kit.

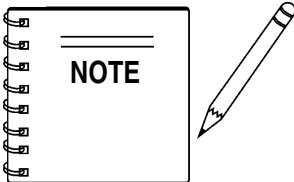

If more than one of the same reference number is listed, the last one listed indicates newest (or latest) part available.

MQ GA-2.9R — SUGGESTED SPARE PARTS

MQ GA-2.9R GENERATOR 1 TO 3 UNITS WITH ROBIN EX170D20210 ENGINE

1 to 3 Units

| Qty. | P/N | Description |
|---------|-------------------|------------------------|
| 1 | A9924800014 | CAP, FUEL TANK |
| 1 | A9924800004 | FUEL FILTER, FUEL TANK |
| 3 | 0650140150 | SPARK PLUG |
| 3 | 2772361407 | ELEMENT, AIR CLEANER |
| 1 | 5825011118 | ROPE, RECOIL STARTER |

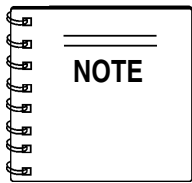

Part numbers on this
Suggested Spare Parts
List may supercede/
replace the P/N shown in
the text pages of this
book.

MQ GA-2.9R — NAME PLATE AND DECALS

NAMEPLATE AND DECALS.

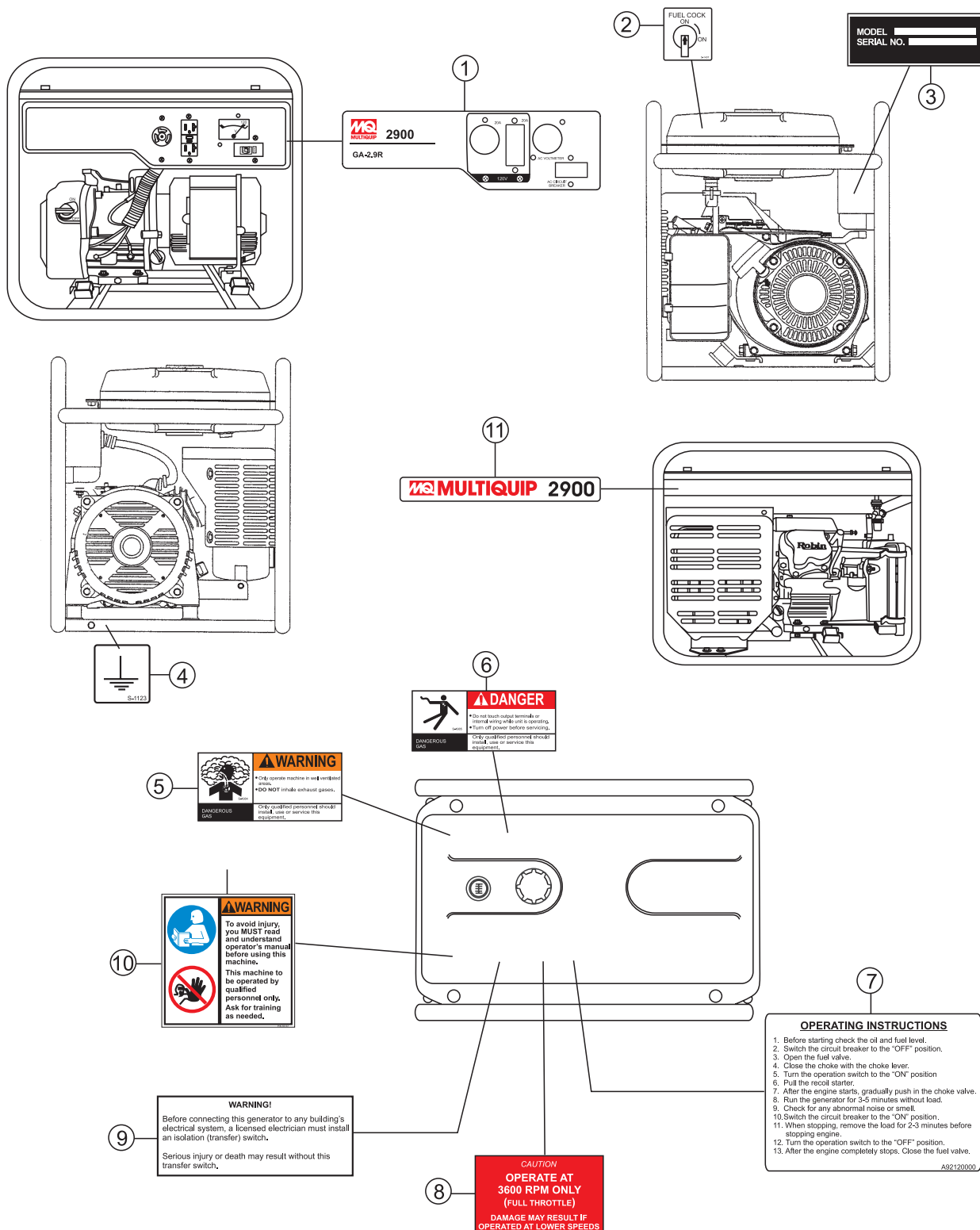

MQ GA-2.9R — NAME PLATE AND DECALS

NAMEPLATE DECALS.

| <u>NO.</u> | <u>PART NO.</u> | <u>PART NAME</u> | <u>QTY.</u> | <u>REMARKS</u> |
|------------|-----------------|---|-------------|------------------------|
| 1 | A2511201002 | DECAL; CONTROL PANEL | 1 | A21120100 |
| 2 | 1630680104 | DECAL; FUEL COCK | 1 | S-1407 |
| 3 | | NAMEPLATE | 1 | CONTACT MQ PARTS DEPT. |
| 4 | 0800628504 | DECAL; GROUND | 1 | S-1123 |
| 5 | 8700611804 | DECAL; WARNING DANGEROUS GAS | 1 | S-4984 |
| 6 | 8700611904 | DECAL; DANGER ELECTRICAL SHOCK HAZ. | 1 | S-4985 |
| 7 | A92120000 | DECAL; OPERATING INSTRUCTIONS | 1 | |
| 8 | 7900636004 | DECAL; CAUTION OPER. AT 3600 RPM ONLY | 1 | S-4461 |
| 9 | 0820610404 | DECAL; WARNING | 1 | S-3627 |
| 10 | 35137 | DECAL; CAUTION | 1 | |
| 11 | A2561000103 | DECAL; MQ MULTIQUIP 2900 | 1 | |

MQ GA-2.9R — GENERATOR ASSY.

GENERATOR ASSY.

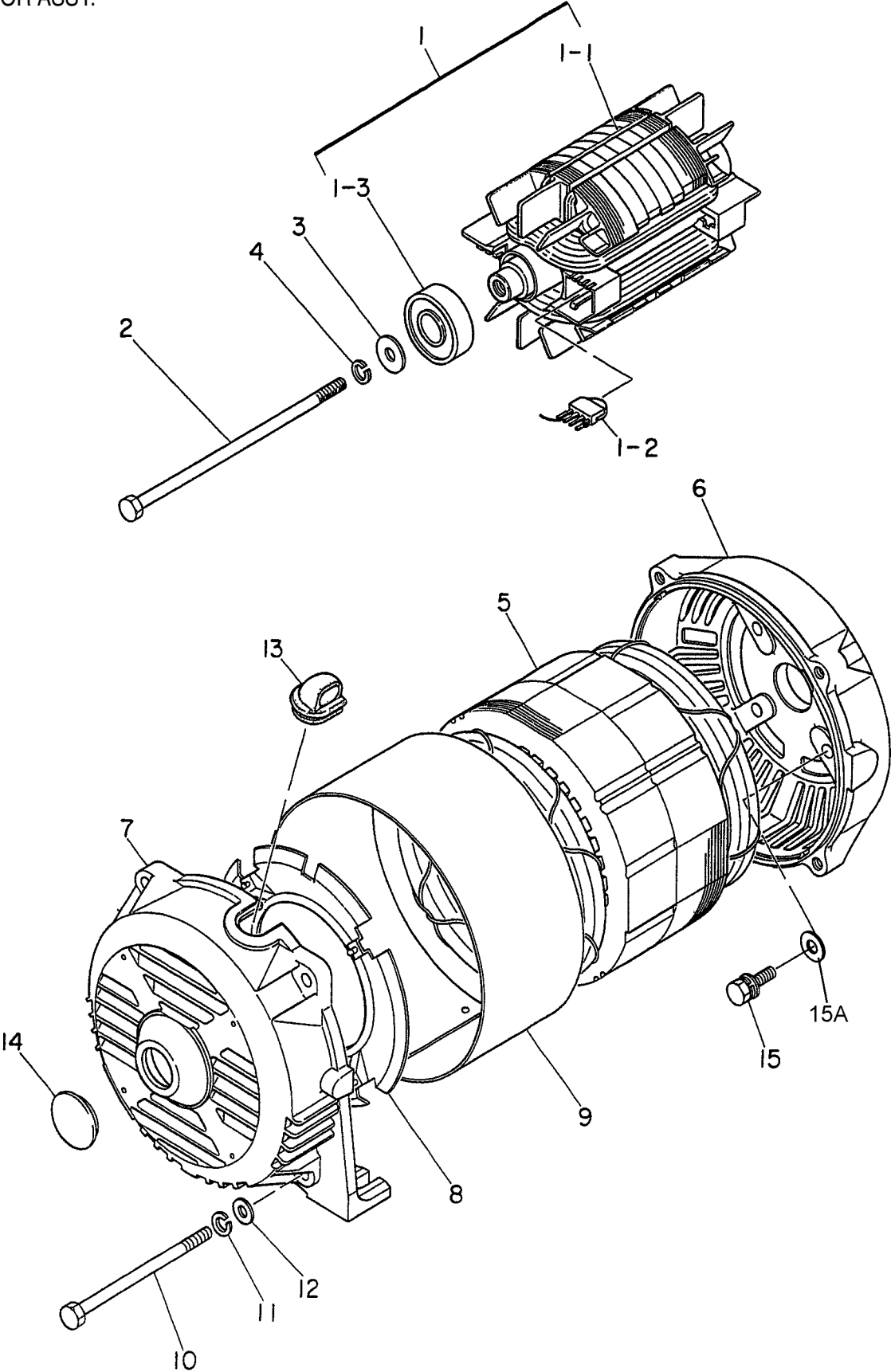

MQ GA-2.9R — GENERATOR ASSY.

GENERATOR ASSY.

| <u>NO</u> | <u>PART NO</u> | <u>PART NAME</u> | <u>QTY.</u> | <u>REMARKS</u> |
|-----------|----------------|-----------------------|-------------|-----------------------|
| 1 | 7931000203 | ROTOR ASSY. | 1 | INCLUDES ITEMS W/* |
| 1-1* | | FIELD COIL ASSY. | 1 | NOT SOLD SEPERATELY |
| 1-2 | 0601823213 | RECTIFIER | 2 | D3SB 80 |
| 1-2 | 0601822638 | SURGE ABSORBER | 2 | TNR 15G431K |
| 1-3* | 0603000040 | BEARING | 1 | 6204 2RU NY5C S30 |
| 2 | 7681017104 | SET BOLT, ROTOR | 1 | |
| 3 | 0801086004 | SET WASHER, BEARING | 1 | |
| 4 | 0040008000 | SPRING WASHER | 1 | |
| 5 | 7921341803 | ARMATURE ASSY. | 1 | S/N 5497956 AND BELOW |
| 5 | A2135000203 | ARMATURE ASSY. | 1 | S/N 5497957 AND ABOVE |
| 6 | 7931315002 | END BRACKET (C SIDE) | 1 | |
| 7 | 7931315102 | END BRACKET (B SIDE) | 1 | |
| 8 | 7875021523 | GUIDE PANEL, AIR | 1 | |
| 9 | 7681331003 | COVER | 1 | |
| 10 | 7681344204 | SET BOLT, STATOR | 4 | |
| 11 | 0040006000 | SPRING WASHER | 4 | |
| 12 | 0041206000 | PLAIN WASHER | 4 | |
| 13 | 7871329514 | GROMMET | 1 | |
| 14 | 0601851760 | CAP | 1 | |
| 15 | 0013608025 | HEX. HEAD BOLT | 4 | S/N 5497956 AND BELOW |
| 15 | 0013608020 | HEX. HEAD BOLT | 4 | S/N 5497957 AND ABOVE |
| 15A | 0040008000 | SPRING WASHER | 4 | |

MQ GA-2.9R — CONTROL BOX ASSY.

CONTROL BOX ASSY.

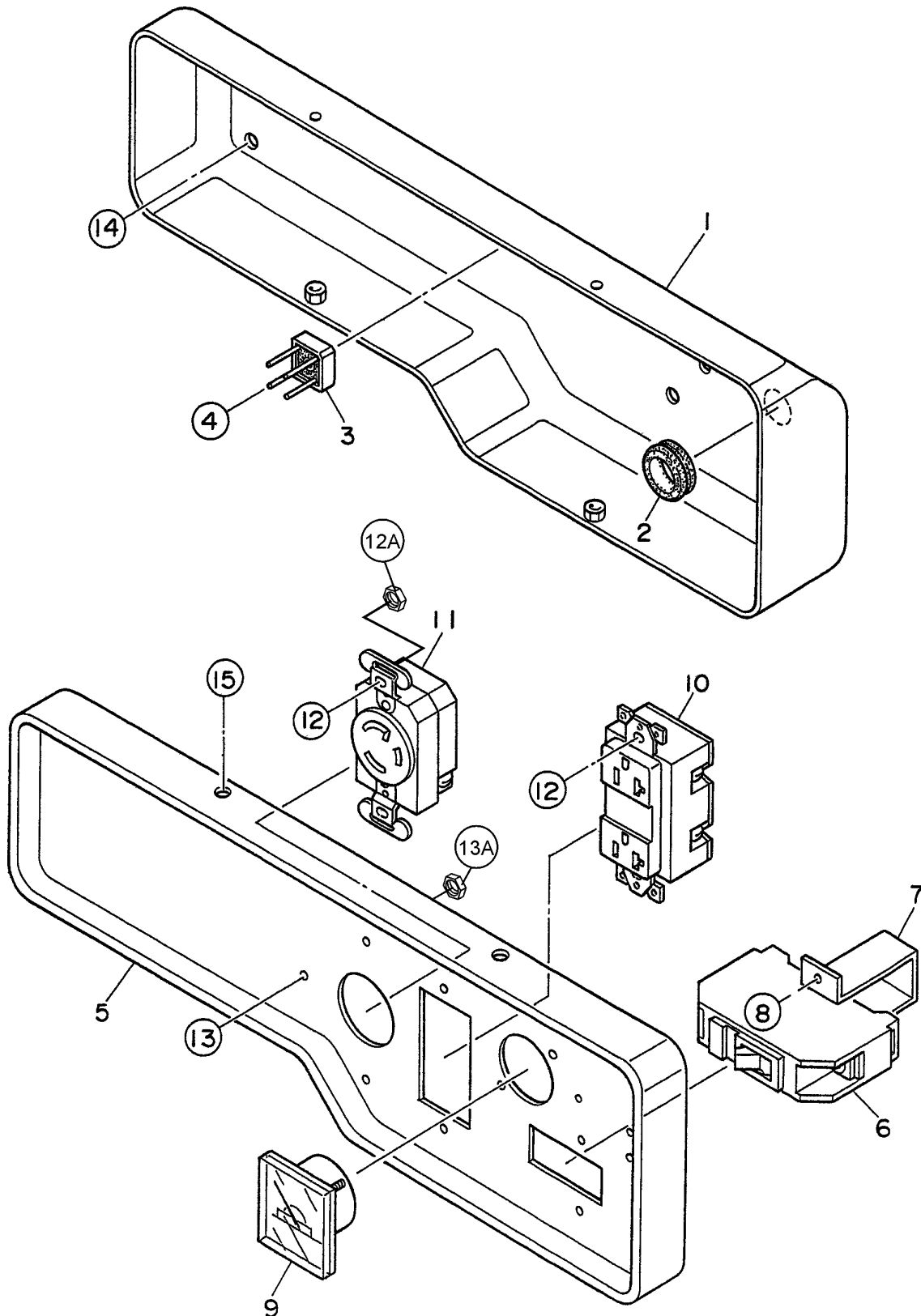

MQ GA-2.9R — CONTROL BOX ASSY.

CONTROL BOX ASSY.

| <u>NO</u> | <u>PART NO</u> | <u>PART NAME</u> | <u>QTY.</u> | <u>REMARKS</u> |
|-----------|----------------|--------------------------|-------------|----------------------|
| 1 | A0101000103 | CONTROL BOX | 1 | |
| 2 | 0801354504 | GROMMET | 1 | |
| 3 | 0601823204 | RECTIFIER | 1 | S5VB60 |
| 4 | 0027103012 | MACHINE SCREW | 1 | |
| 5 | A2224000103 | CONTROL PANEL | 1 | |
| 6 | 0601804889 | CIRCUIT BREAKER..... | 1 | KM-51 : 22A |
| 7 | 3011816004 | BRACKET, CIRCUIT BREAKER | 1 | |
| 8 | 0021004010 | MACHINE SCREW | 2 | |
| 9 | 0601806819 | AC VOLTMETER | 1 | DE450-011 : 0 ~ 120V |
| 10 | 0601812598 | RECEPTACLE | 1 | 5-20R: 125V, 20A |
| 11 | 0601812592 | RECEPTACLE | 1 | L5-20R:125V, 20A |
| 12 | 0021004010 | MACHINE SCREW | 4 | |
| 12A | 0207004000 | HEX NUT | 4 | |
| 13 | 0021004015 | MACHINE SCREW | 4 | |
| 13A | 0207004000 | HEX NUT | 1 | |
| 14 | 0017106016 | HEX. HEAD BOLT | 4 | |
| 15 | 0017105010 | HEX. HEAD BOLT | 4 | |

MQ GA-2.9R — PIPE FRAME ASSY.

PIPE FRAME ASSY.

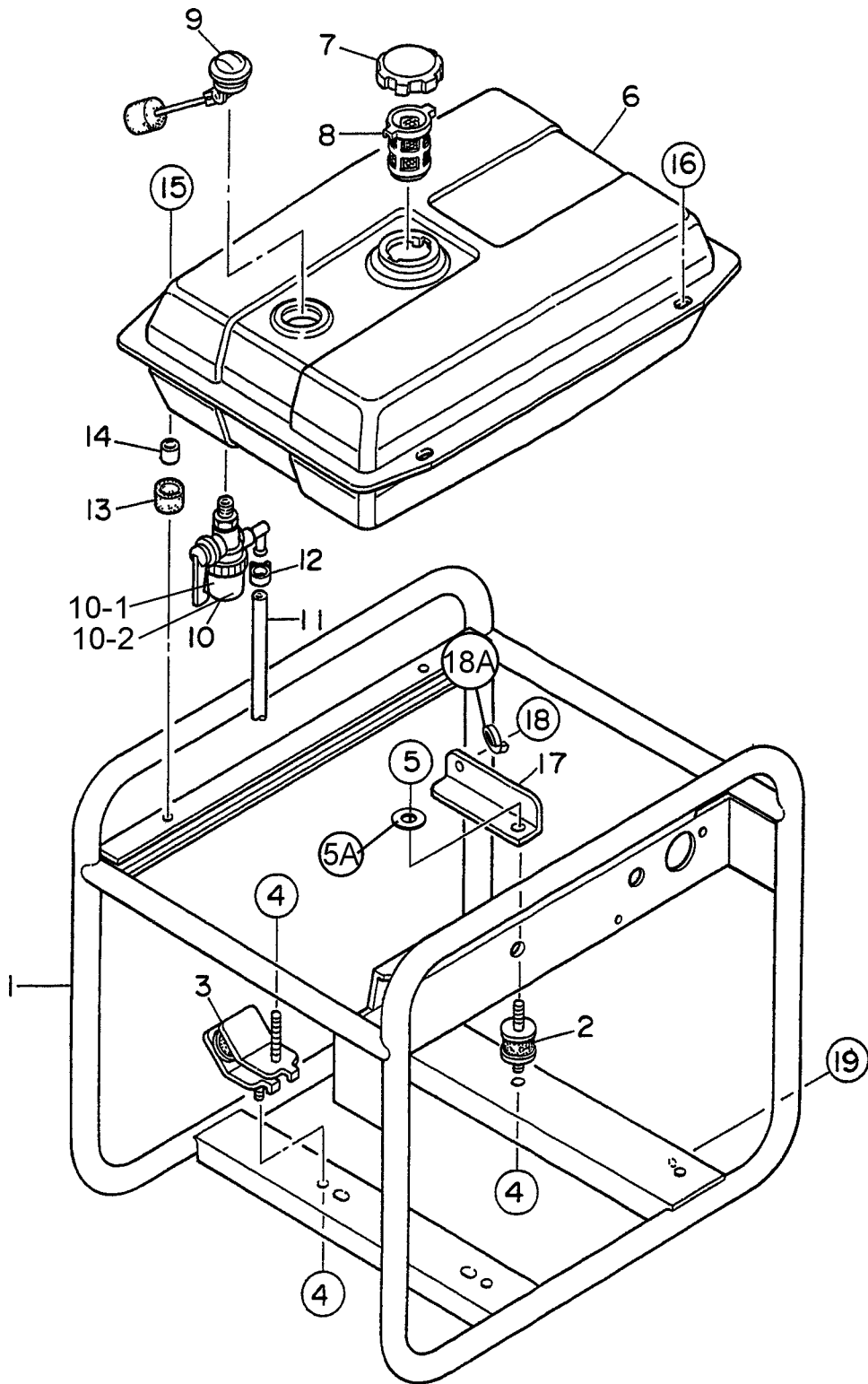

MQ GA-2.9R — PIPE FRAME ASSY.

PIPE FRAME ASSY.

| <u>NO</u> | <u>PART NO</u> | <u>PART NAME</u> | <u>QTY.</u> | <u>REMARKS</u> |
|-----------|----------------|----------------------------|-------------|--------------------|
| 1 | A2417000302 | PIPE FRAME | 1 | |
| 2 | 7935419204 | RUBBER SUSPENSION | 2 | |
| 3 | 7935416004 | RUBBER SUSPENSION | 2 | |
| 4 | 0207008000 | HEX. NUT | 6 | |
| 5 | 0207008000 | HEX. NUT | 2 | |
| 5A | 0801086004 | WASHER | 1 | |
| 6 | A2365000102 | FUEL TANK | 1 | |
| 7 | A9924800014 | CAP, FUEL TANK | 1 | |
| 8 | A9924800004 | FUEL FILTER | 1 | |
| 9 | 0602125034 | FUEL GAUGE, CJ- 58A | 1 | |
| 10 | 0605510028 | FUEL STRAINER | 1 | INCLUDES ITEMS W/* |
| 10-1* | 0642007810 | CUP, FILTER, FUEL STRAINER | 1 | |
| 10-2* | 0642006410 | PACKING, FUEL STRAINER | 1 | |
| 11 | 0605513169 | HOSE | 1 | |
| 12 | 0605515061 | HOSE BAND | 2 | |
| 13 | 7855525514 | RUBBER CUSHION | 2 | |
| 14 | 7855525604 | COLLAR | 2 | |
| 15 | 0016908030 | HEX. HEAD BOLT | 2 | |
| 16 | 0016908020 | HEX. HEAD BOLT | 2 | |
| 17 | A2331400004 | BRACKET | 1 | |
| 18 | 0013606016 | HEX. HEAD BOLT | 2 | |
| 18A | 0040106000 | SPRING WASHER | 1 | |
| 19 | 0019206016 | HEX. HEAD BOLT | 1 | |

ROBIN EX170D20210 — CRANKCASE ASSY.

CRANKCASE ASSY..

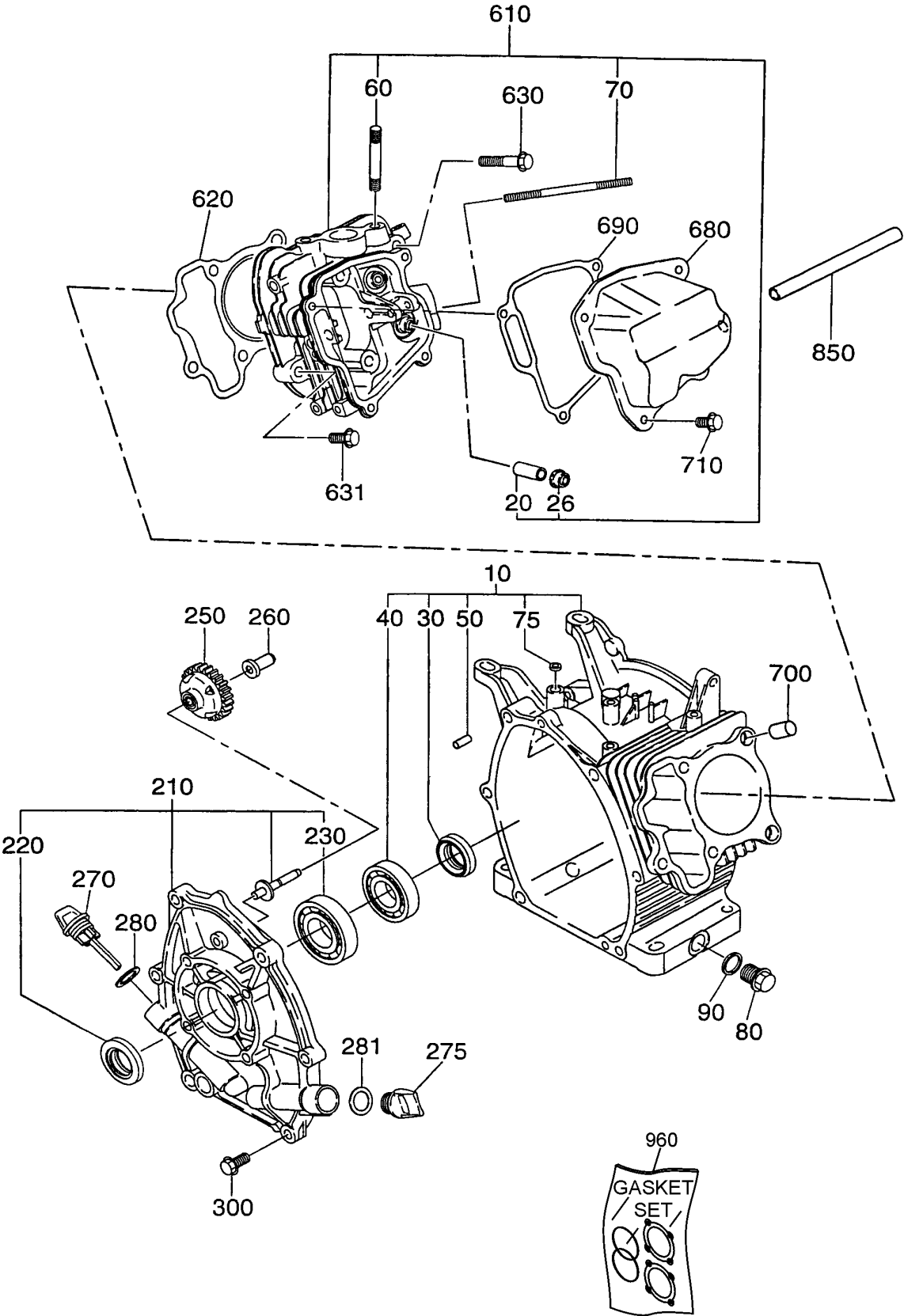

ROBIN EX170D20210— CRANKCASE ASSY.

CRANKCASE ASSY.

| <u>NO</u> | <u>PART NO</u> | <u>PART NAME</u> | <u>QTY.</u> | <u>REMARKS</u> |
|-----------|----------------|----------------------------|-------------|-------------------|
| 10 | 2771010241 | CRANKCASE CP | 1 | INCLUDES ITEM W/* |
| 20# | 2371420103 | VALVE GUIDE | 2 | |
| 26# | 2771601001 | STEM SEAL | 1 | |
| 30* | 0440250200 | OIL SEAL | 1 | |
| 40* | 0600280021 | BALL BEARING | 1 | |
| 50* | 2771501103 | PIPE KNOCK | 2 | |
| 60# | 0105080250 | STUD | 2 | |
| 70# | 0105060351 | STUD | 2 | |
| 75* | 0440060020 | OIL SEAL | 1 | |
| 80 | 0401140030 | PLUG | 2 | |
| 90 | 0211140020 | GASKET | 2 | |
| 210 | 2771100131 | MAIN BEARING COVER C | 1 | INCLUDES ITEM W/% |
| 220% | 0440250210 | OIL SEAL | 1 | |
| 230% | 0600250140 | BALL BEARING, 6205 | 1 | |
| 250 | 2774500141 | GOVERNOR GEAR CP | 1 | |
| 260 | 2774190103 | GOVERNOR SLEEVE | 1 | |
| 270 | 2776360113 | OIL GAUGE | 1 | |
| 275 | 2776500103 | FILLER PLUG | 1 | |
| 280 | 0213160020 | GASKET | 1 | |
| 281 | 0213160020 | GASKET | 1 | |
| 300 | 0010408350 | FLANGE BOLT | 6 | |
| 610 | 2771300111 | CYLINDER HEAD CP | 1 | INCLUDES ITEM W/# |
| 620 | 2771500123 | GASKET, HEAD | 1 | |
| 630 | 0110080240 | FLANGE BOLT | 4 | |
| 631 | 0010408350 | FLANGE BOLT | 1 | |
| 680 | 2771550101 | ROCKER COVER CP | 1 | |
| 690 | 2771600103 | GASKET, ROCKER COVER | 1 | |
| 700 | 2771501103 | PIPE KNOCK | 2 | |
| 710 | 0110060020 | FLANGE BOLT | 4 | |
| 850 | 0851080000 | RUBBER PIPE | 1 | |
| 960 | 2779900107 | GASKET SET | 1 | |

ROBIN EX170D20210 — CRANKSHAFT AND PISTON ASSY.

CRANKSHAFT AND PISTON ASSY.

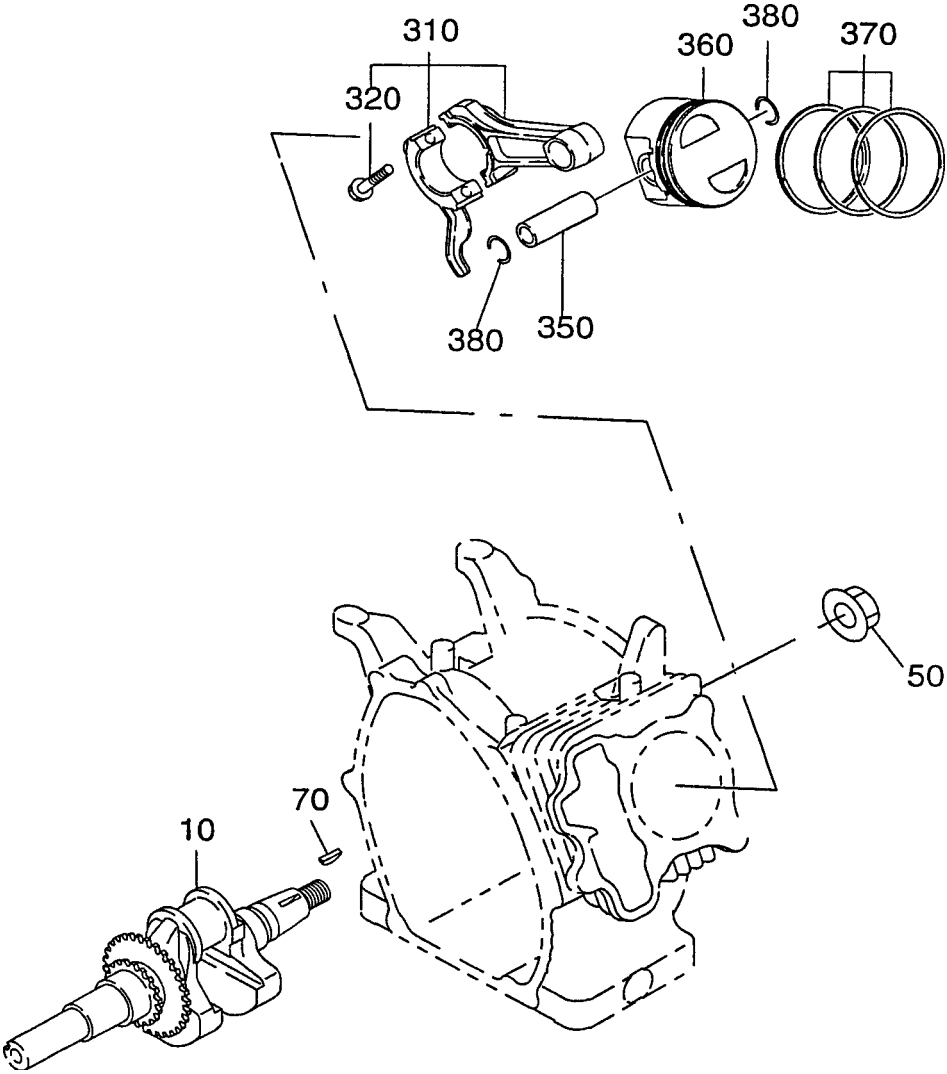

ROBIN EX170D20210 — CRANKSHAFT AND PISTON ASSY.

CRANKSHAFT ASSY.

| <u>NO</u> | <u>PART NO</u> | <u>PART NAME</u> | <u>QTY.</u> | <u>REMARKS</u> |
|-----------|----------------|-----------------------------------|-------------|--------------------|
| 10 | 2772020121 | CRANKSHAFT CP | 1 | |
| 50 | 0180140020 | FLANGE NUT | 1 | |
| 70 | 0323030010 | WOODRUFF KEY | 1 | |
| 310 | 2772250110 | CONNECTING ROD ASSY. | 1 | INCLUDES ITEMS W/* |
| 320* | 2772300103 | CONNECTING ROD BOLT | 2 | |
| 350 | 2772330103 | PISTON PIN | 1 | |
| 360 | 2772340103 | PISTON | 1 | |
| 360 | 2772340303 | PISTON, OVERSIZE 0.25 MM | 1 | |
| 360 | 2772340403 | PISTON, OVERSIZE 0.50 MM | 1 | |
| 370 | 2772351107 | PISTON RING SET | 1 | |
| 370 | 2772351217 | PISTON RING SET, OVERSIZE 0.25 MM | 1 | |
| 370 | 2772351317 | PISTON RING SET, OVERSIZE 0.50 MM | 1 | |
| 380 | 0565160010 | CLIP | 2 | |

ROBIN EX170D20210 — GOVERNOR ASSY.

GOVERNOR ASSY.

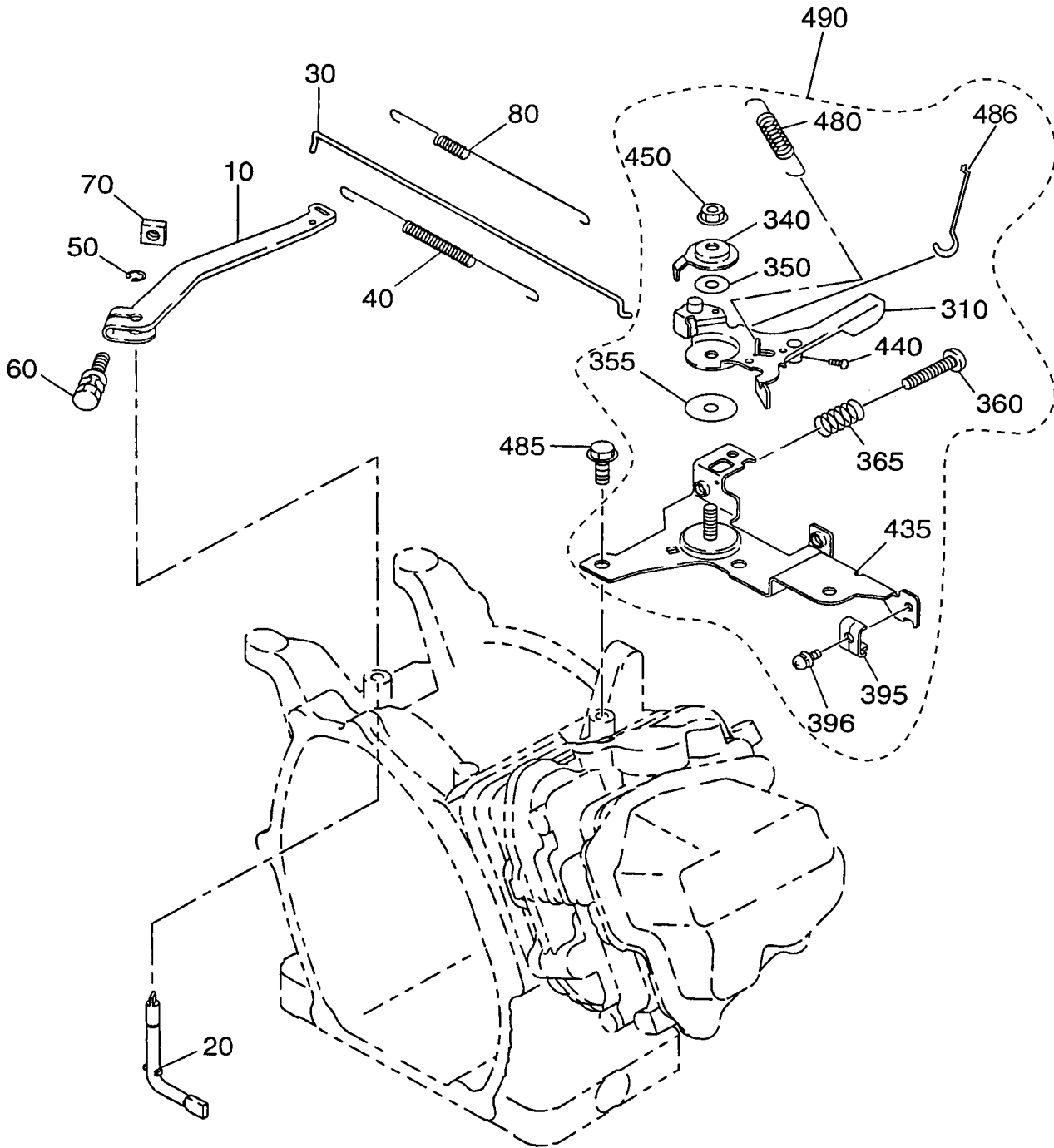

ROBIN EX170D20210 — GOVERNOR ASSY.

GOVERNOR ASSY.

| <u>NO</u> | <u>PART NO</u> | <u>PART NAME</u> | <u>QTY.</u> | <u>REMARKS</u> |
|-----------|----------------|---------------------------|-------------|--|
| 10 | 2774230113 | GOVERNOR LEVER | 1 | |
| 20 | 2774220133 | GOVERNOR SHAFT | 1 | |
| 30 | 2774270101 | GOVERNOR ROD CP | 1 | |
| 40 | 2774280113 | ROD SPRING | 1 | |
| 50 | 0031305000 | CLIP | 1 | |
| 60 | 0130060240 | BOLT & WASHER ASSY. | 1 | |
| 70 | 0186060020 | NUT | 1 | |
| 80 | 2794250223 | GOVERNOR SPRING | 1 | |
| 80 | 2764250533 | GOVERNOR SPRING | 1 | |
| 310* | 2774330301 | SPEED CONTROL LEVER | 1 | |
| 340* | 2774350103 | STOP PLATE | 1 | |
| 350* | 0200060170 | WASHER | 1 | |
| 355* | 0217060070 | FRICTION, WASHER | 1 | |
| 360* | 0043106250 | SCREW | 1 | |
| 365* | 2374500423 | SPRING, ADJUST | 1 | |
| 395* | 2774390203 | CLAMP | 1 | |
| 396* | 0131050030 | SCREW & WASHER ASSY. | 1 | |
| 435* | 2774600201 | SPEED CONT. BRKT CP | 1 | CAN ONLY BE PURCHASED W/ITEM 490 |
| 440* | 0043104080 | SCREW | 1 | |
| 450* | 0023506000 | SELF LOCK NUT | 1 | |
| 480* | 674510103 | RETURN SPRING | 1 | |
| 485 | 0110060020 | FLANGE BOLT | 2 | |
| 486* | 2774370101 | LINK ROD | 1 | |
| 490 | 2774600210 | SPEED CONTROL ASSY. | 1 | INCLUDES ITEMS W/* |

ROBIN EX170D20210 — INTAKE AND EXHAUST ASSY.

INTAKE AND EXHAUST ASSY.

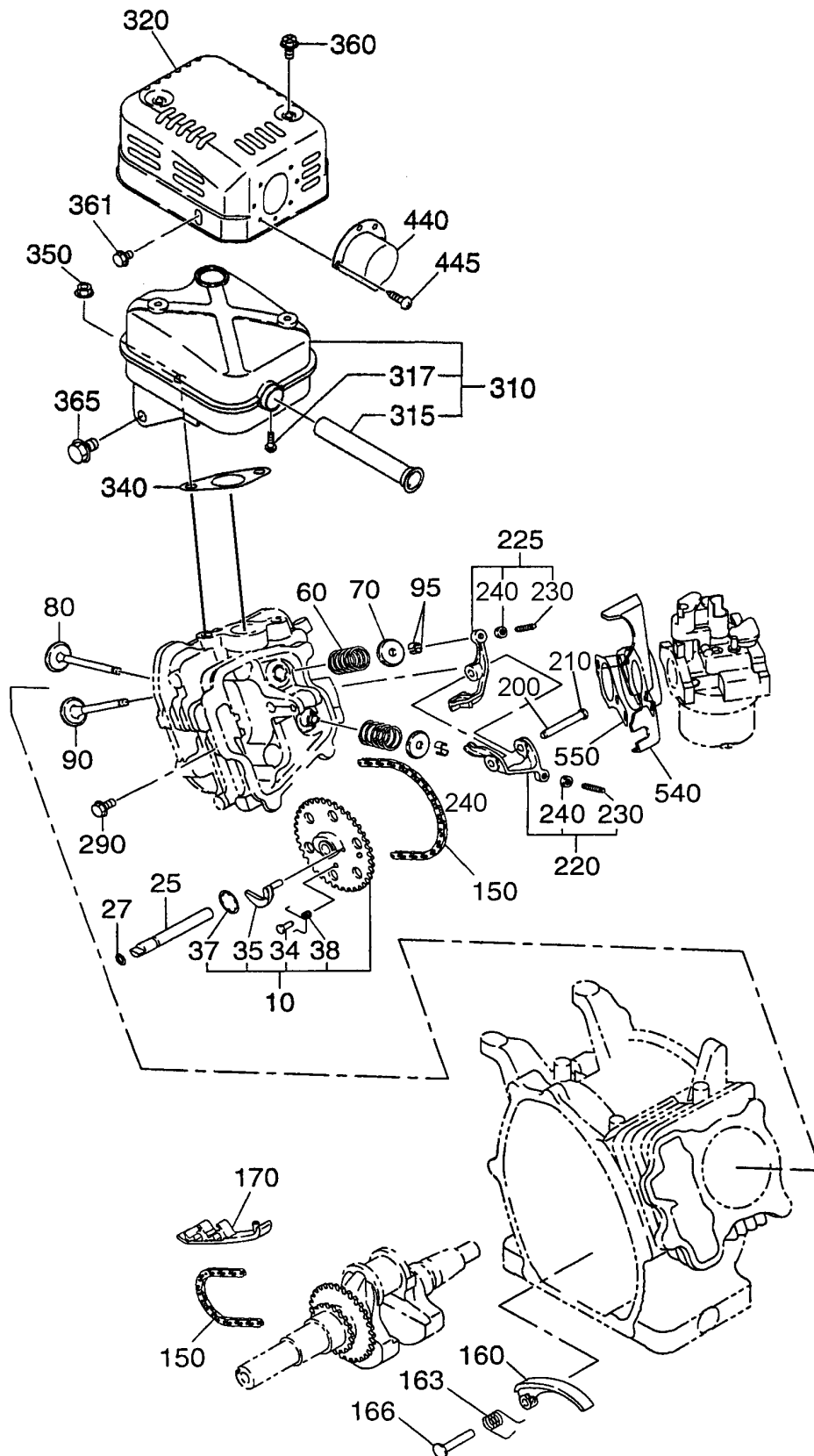

ROBIN EX170D20210 — INTAKE AND EXHAUST ASSY.

INTAKE AND EXHAUST ASSY.

| <u>NO</u> | <u>PART NO</u> | <u>PART NAME</u> | <u>QTY.</u> | <u>REMARKS</u> |
|-----------|----------------|------------------------------|-------------|--------------------|
| 10 | 2773160111 | CAM SHAFT CP | 1 | INCLUDES ITEMS W/% |
| 25 | 2773510103 | PIN, CAM SHAFT | 1 | |
| 27 | 0240060010 | O-RING | 1 | |
| 34% | 2773860103 | PIN, SPRING | 1 | |
| 35% | 2773640103 | RELEASE LEVER | 1 | |
| 37% | 2773650103 | CLIP | 1 | |
| 38% | 2773870203 | RETURN SPRING | 1 | |
| 60 | 2793360103 | VALVE SPRING | 2 | |
| 70 | 2693370103 | SPRING RETAINER | 2 | |
| 80 | 2773340113 | INTAKE VALVE | 1 | |
| 90 | 2773350113 | EXHAUST VALVE | 1 | |
| 95 | 13210KA031 | COLLET VALVE | 4 | |
| 150 | 2773560111 | TIMING CHAIN CP | 1 | |
| 160 | 2773691103 | TENTIONER | 1 | |
| 163 | 2773710103 | SPRING, TENTIONER | 1 | |
| 166 | 2773690203 | PIN, TENTIONER | 1 | |
| 170 | 2773691313 | CHAIN GUIDE | 1 | |
| 200 | 2773500203 | PIN, ROCKER | 1 | |
| 210 | 0031305000 | CLIP | 1 | |
| 220 | 2773620100 | ROCKER ARM, IN, ASSY. | 1 | INCLUDES ITEM W/+ |
| 225 | 2773620200 | ROCKER ARM, EX, ASSY. | 1 | INCLUDES ITEM W/+ |
| 230+ | 0149050020 | ADJUST SCREW | 1 | |
| 240+ | 0170050020 | NUT | 1 | |
| 290 | 0110060020 | FLANGE BOLT | 1 | |
| 310 | 2773011101 | MUFFLER/SPARK ARRESTOR | 1 | INCLUDES ITEMS W/* |
| 315* | 2773760101 | SPARK ARRESTOR | 1 | |
| 317* | 0150040060 | TAPPING SCREW | 1 | |
| 320 | 2773240111 | MUFFLER COVER CP | 1 | |
| 340 | 2773520113 | GASKET, MUFFLER | 1 | |
| 350 | 9802008280 | FLANGE NUT | 2 | |
| 360 | 0152060090 | TAPPING BOLT | 2 | |
| 361 | 0110060010 | FLANGE BOLT | 1 | |
| 365 | 0110080150 | FLANGE BOLT | 1 | |
| 440 | 2773700103 | DEFLECTOR | 1 | |
| 445 | 0150040060 | TAPPING SCREW | 2 | |
| 540 | 2773290113 | INSULATOR | 1 | |
| 550 | 2773590113 | GASKET, INSULATOR | 1 | |

ROBIN EX170D20210 — AIR CLEANER ASSY.

AIR CLEANER ASSY.

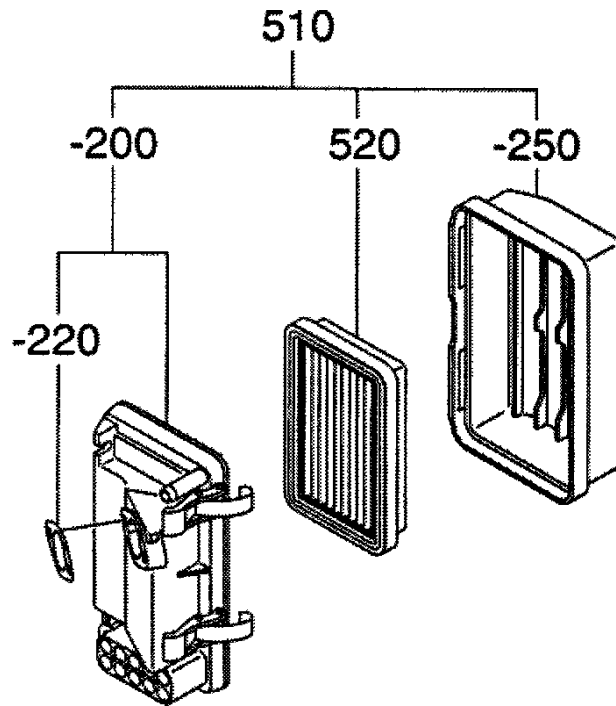

ROBIN EX170D20210 — AIR CLEANER ASSY.

AIR CLEANER ASSY.

| <u>NO.</u> | <u>PART NO.</u> | <u>PART NAME</u> | <u>QTY.</u> | <u>REMARKS</u> |
|------------|-----------------|---------------------------------|-------------|--------------------|
| 510 | 2773262010 | AIR CLEANER ASSY. (LOW PROFILE) | 1 | INCLUDES ITEMS W/* |
| 510-200* | 2773261318 | BACK PLATE | 1 | |
| 510-220* | 2773260408 | GASKET | 1 | |
| 510-250* | 2773261228 | COVER | 1 | |
| 520* | 2773261407 | ELEMENT ASSY., LOW PROFILE | 1 | |

ROBIN EX170D20210 — COOLING STARTING ASSY.

COOLING STARTING ASSY.

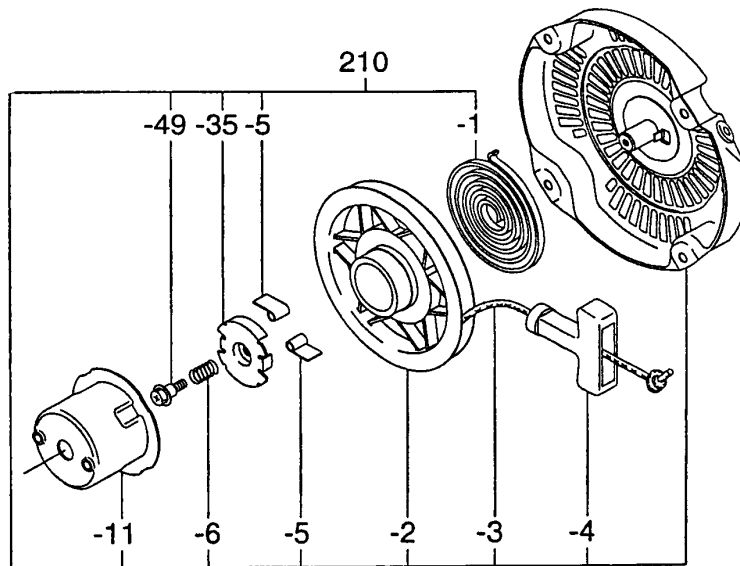
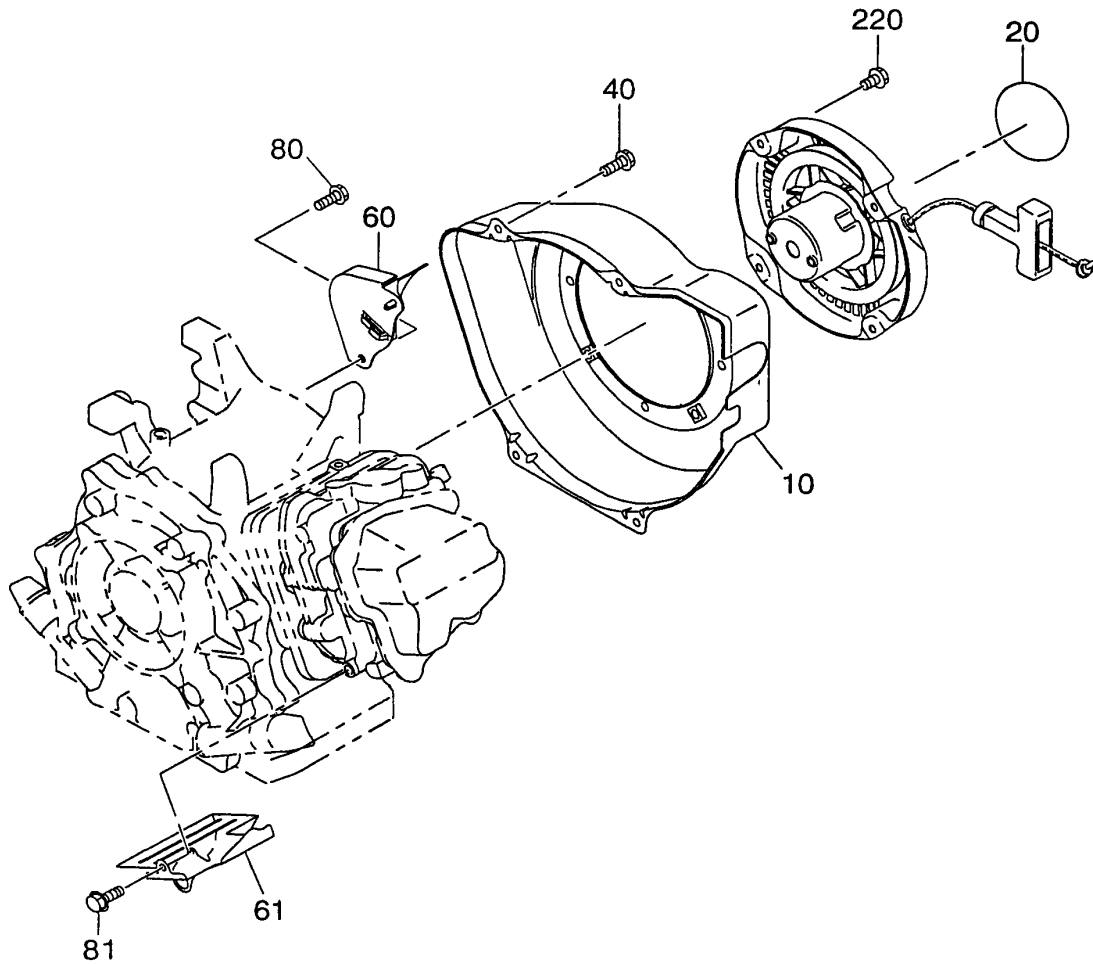

ROBIN EX170D20210 — COOLING STARTING ASSY.

COOLING STARTING ASSY.

| <u>NO</u> | <u>PART NO</u> | <u>PART NAME</u> | <u>QTY.</u> | <u>REMARKS</u> |
|-----------|----------------|---------------------------|-------------|-------------------|
| 10 | 2775120201 | BLOWER HOUSING CP | 1 | |
| 20 | 0732005140 | LABEL, TRADEMARK | 1 | |
| 40 | 0110060030 | FLANGE BOLT | 4 | |
| 60 | 2775271111 | BAFFLE 1, CASE CP | 1 | |
| 61 | 2775270203 | BAFFLE 2, HEAD | 1 | |
| 80 | 0010406160 | FLANGE BOLT | 1 | |
| 81 | 0110060020 | FLANGE BOLT | 1 | |
| 210 | 2695020130 | RECOIL STARTER ASSY. | 1 | INCLUDES ITEM W/* |
| 210-1* | 2705011508 | SPIRAL SPRING | 1 | |
| 210-2* | 2695012008 | REEL | 1 | |
| 210-3* | 5825011118 | STARTER ROPE | 1 | |
| 210-4* | 2615010008 | STARTER KNOB | 1 | |
| 210-5* | 2705012508 | RATCHET | 2 | |
| 210-6* | 2275013108 | FRICTION SPRING | 1 | |
| 210-11* | 2695014518 | STARTER PULLEY | 1 | |
| 210-35* | 2705026108 | RATCHET GUIDE | 1 | |
| 210-49* | 2275015208 | SET SCREW | 1 | |
| 220 | 0110060010 | FLANGE BOLT | 4 | |

ROBIN EX170D20210 — CARBURETOR ASSY.

CARBURETOR ASSY.

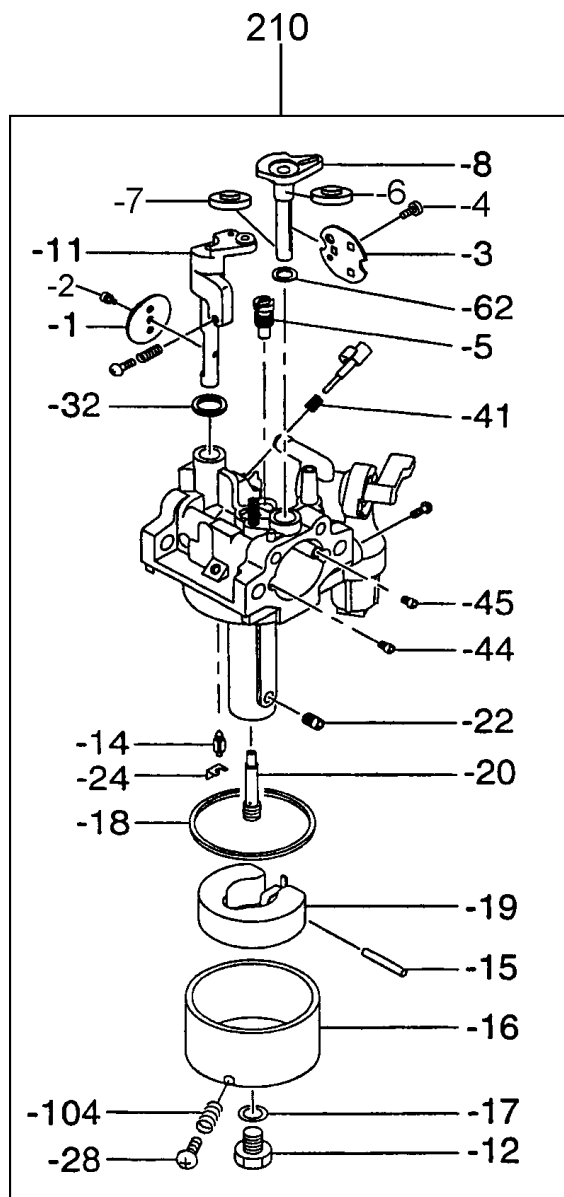

ROBIN EX170D20210 — CARBURETOR ASSY.

CARBURETOR ASSY.

| <u>NO</u> | <u>PART NO</u> | <u>PART NAME</u> | <u>QTY.</u> | <u>REMARKS</u> |
|-----------|----------------|---------------------------|-------------|-------------------|
| 210 | 2776230420 | CARBURETOR ASSY. | 1 | INCLUDES ITEM W/* |
| 210-1* | 2776253508 | THROTTLE VALVE | 1 | |
| 210-2* | 2096235108 | THROTTLE SCREW | 1 | |
| 210-3* | 2776252708 | CHOKE VALVE | 1 | |
| 210-4* | 2376245108 | SCREW, CHOKE, LOW PROFILE | 1 | |
| 210-5* | 2466242008 | PILOT JET, #40 | 1 | |
| 210-6* | 2776257008 | RING, UPPER, LOW PROFILE | 1 | |
| 210-7* | 2776257108 | RING, LOWER, LOW PROFILE | 1 | |
| 210-8* | 2776256008 | CHOKE LEVER | 1 | |
| 210-11* | 2776253108 | THROTTLE SHAFT | 1 | |
| 210-12* | 2276245108 | BOLT | 1 | |
| 210-14* | 2776250008 | NEEDLE | 1 | |
| 210-15* | 2776251508 | PIN | 1 | |
| 210-16* | 2776250608 | FLOAT BODY | 1 | |
| 210-17* | 2146245008 | PACKING | 1 | |
| 210-18* | 2146254008 | CHAMBER PACKING | 1 | |
| 210-19* | 2266250608 | FLOAT ASSY. | 1 | |
| 210-20* | 2776244008 | MAIN NOZZLE | 1 | |
| 210-22* | 2266241108 | MAIN JET, #77.5 | 1 | |
| 210-22* | 2776241208 | MAIN JET, #76.3 | 1 | |
| 210-24* | 2266270118 | CLIP | 1 | |
| 210-28* | 2776236008 | BOLT | 1 | |
| 210-32* | 2466239008 | SEAL | 1 | |
| 210-44* | 2486241008 | AIR JET | 1 | |
| 210-45* | 1066241008 | AIR JET, PILOT | 1 | |
| 210-62* | 2366268008 | SEAL | 1 | |
| 210-104* | 2366254108 | PACKING | 1 | |

ROBIN EX170D20210 — FLYWHEEL ASSY.

FLYWHEEL ASSY.

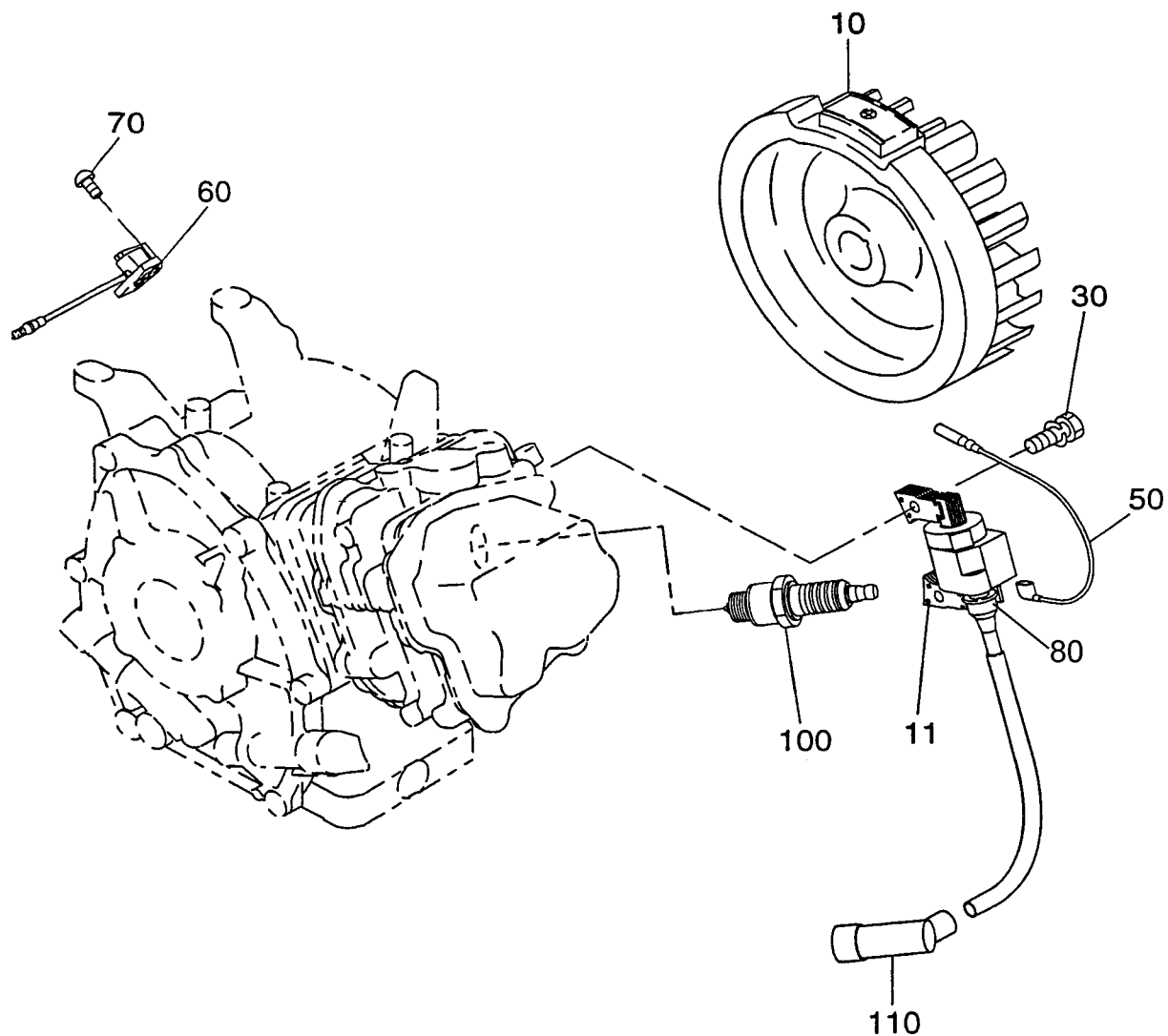

ROBIN EX170D20210 — FLYWHEEL ASSY.

FLYWHEEL ASSY.

| <u>NO</u> | <u>PART NO</u> | <u>PART NAME</u> | <u>QTY.</u> | <u>REMARKS</u> |
|-----------|----------------|------------------|-------------|----------------|
| 10 | 2777923011 | FLYWHEEL CP | 1 | |
| 11 | 2777943101 | IGNITION COIL CP | 1 | |
| 30 | 0011406250 | BOLT & WASHER | 2 | |
| 50 | 27773101H1 | WIRE 1 CP | 1 | |
| 60 | X660000361 | SWITCH ASSY. | 1 | |
| 70 | 0150040090 | TAPPING SCREW | 2 | |
| 80 | 0241070110 | GROMMET | 1 | |
| 100 | 0650140150 | SPARK PLUG | 1..... | NGK BR6HS |
| 110 | 0655000270 | SPARK PLUG CAP | 1 | |

ROBIN EX170D20210 — ELECTRIC DEVICE ASSY.

ELECTRIC DEVICE ASSY.

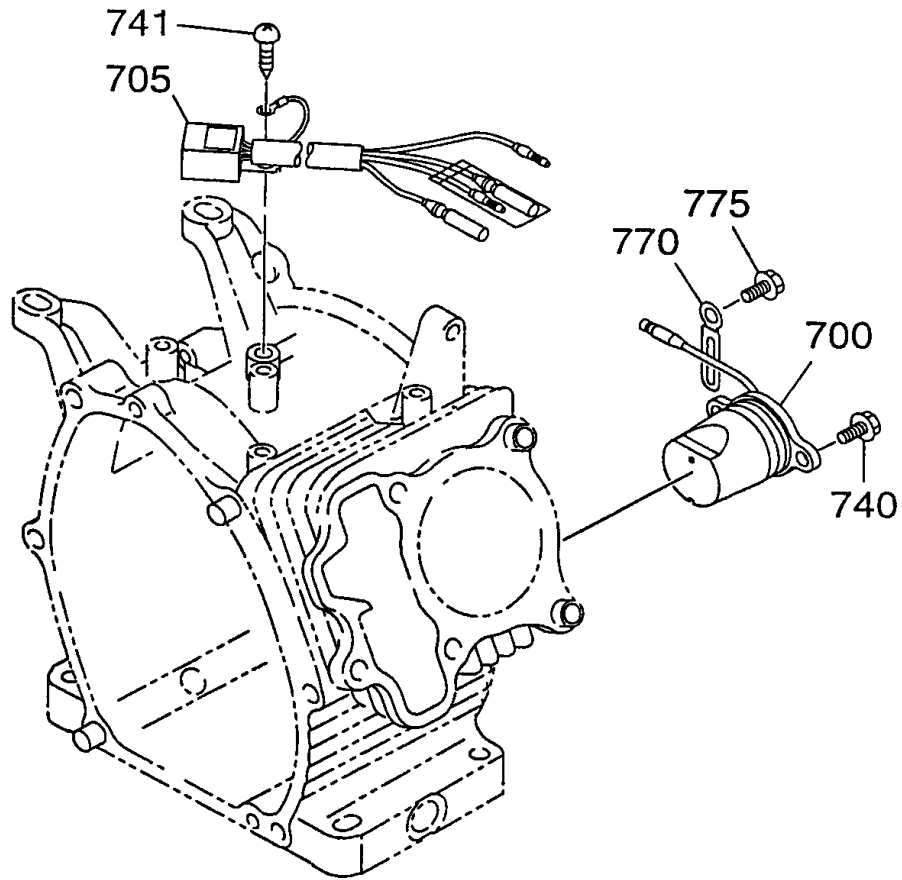

ROBIN EX170D20210 — ELECTRIC DEVICE ASSY.

ELECTRIC DEVICE ASSY.

| <u>NO</u> | <u>PART NO</u> | <u>PART NAME</u> | <u>QTY.</u> | <u>REMARKS</u> |
|-----------|----------------|---------------------|-------------|----------------|
| 700 | 2777630111 | OIL SENSOR CP | 1 | |
| 705 | KU31104311 | FLOAT, C/U CP3 | 1 | |
| 740 | 0011406160 | BOLT & WASHER ASSY. | 2 | |
| 741 | 0150040090 | TAPPING SCREW | 1 | |
| 770 | 2147900601 | CLAMP CP | 1 | |
| 775 | 0110060020 | FLANGE BOLT | 1 | |

PAYMENT TERMS

Terms of payment for parts are net 10 days.

FREIGHT POLICY

All parts orders will be shipped collect or prepaid with the charges added to the invoice. All shipments are F.O.B. point of origin. Multiquip's responsibility ceases when a signed manifest has been obtained from the carrier, and any claim for shortage or damage must be settled between the consignee and the carrier.

MINIMUM ORDER

The minimum charge for orders from Multiquip is \$15.00 net. Customers will be asked for instructions regarding handling of orders not meeting this requirement.

RETURNED GOODS POLICY

Return shipments will be accepted and credit will be allowed, subject to the following provisions:

1. A Returned Material Authorization must be approved by Multiquip prior to shipment.
2. To obtain a Return Material Authorization, a list must be provided to Multiquip Parts Sales that defines item numbers, quantities, and descriptions of the items to be returned.
 - a. The parts numbers and descriptions must match the current parts price list.
 - b. The list must be typed or computer generated.
 - c. The list must state the reason(s) for the return.
 - d. The list must reference the sales order(s) or invoice(s) under which the items were originally purchased.
 - e. The list must include the name and phone number of the person requesting the RMA.
3. A copy of the Return Material Authorization must accompany the return shipment.
4. Freight is at the sender's expense. All parts must be returned freight prepaid to Multiquip's designated receiving point.

5. Parts must be in new and resalable condition, in the original Multiquip package (if any), and with Multiquip part numbers clearly marked.
6. The following items are not returnable:
 - a. Obsolete parts. (If an item is in the price book and shows as being replaced by another item, it is obsolete.)
 - b. Any parts with a limited shelf life (such as gaskets, seals, "O" rings, and other rubber parts) that were purchased more than six months prior to the return date.
 - c. Any line item with an extended dealer net price of less than \$5.00.
 - d. Special order items.
 - e. Electrical components.
 - f. Paint, chemicals, and lubricants.
 - g. Decals and paper products.
 - h. Items purchased in kits.
7. The sender will be notified of any material received that is not acceptable.
8. Such material will be held for five working days from notification, pending instructions. If a reply is not received within five days, the material will be returned to the sender at his expense.
9. Credit on returned parts will be issued at dealer net price at time of the original purchase, less a 15% restocking charge.
10. In cases where an item is accepted, for which the original purchase document can not be determined, the price will be based on the list price that was effective twelve months prior to the RMA date.
11. Credit issued will be applied to future purchases only.

PRICING AND REBATES

Prices are subject to change without prior notice. Price changes are effective on a specific date and all orders received on or after that date will be billed at the revised price. Rebates for price declines and added charges for price increases will not be made for stock on hand at the time of any price change.

Multiquip reserves the right to quote and sell direct to Government agencies, and to Original Equipment Manufacturer accounts who use our products as integral parts of their own products.

SPECIAL EXPEDITING SERVICE

A \$35.00 surcharge will be added to the invoice for special handling including bus shipments, insured parcel post or in cases where Multiquip must personally deliver the parts to the carrier.

LIMITATIONS OF SELLER'S LIABILITY

Multiquip shall not be liable hereunder for damages in excess of the purchase price of the item with respect to which damages are claimed, and in no event shall Multiquip be liable for loss of profit or good will or for any other special, consequential or incidental damages.

LIMITATION OF WARRANTIES

No warranties, express or implied, are made in connection with the sale of parts or trade accessories nor as to any engine not manufactured by Multiquip. Such warranties made in connection with the sale of new, complete units are made exclusively by a statement of warranty packaged with such units, and Multiquip neither assumes nor authorizes any person to assume for it any other obligation or liability whatever in connection with the sale of its products. Apart from such written statement of warranty, there are no warranties, express, implied or statutory, which extend beyond the description of the products on the face hereof.

OPERATION AND PARTS MANUAL

HERE'S HOW TO GET HELP

PLEASE HAVE THE MODEL AND SERIAL
NUMBER *ON-HAND* WHEN CALLING

MULTIQUIP CORPORATE OFFICE

18910 Wilmington Ave. 800-421-1244
Carson, CA 90746 FAX: 310-537-3927
Email: mq@multiquip.com
Internet: www.multiquip.com

PARTS DEPARTMENT

800-427-1244 FAX: 800-672-7877
310-537-3700 FAX: 310-637-3284

MAYCO PARTS

800-306-2926 FAX: 800-672-7877
310-537-3700 FAX: 310-637-3284

SERVICE DEPARTMENT

800-421-1244 FAX: 310-537-4259
310-537-3700

TECHNICAL ASSISTANCE

800-478-1244 FAX: 310-631-5032

WARRANTY DEPARTMENT

800-421-1244, EXT. 279 FAX: 310-537-1173
310-537-3700, EXT. 279

Manufactured for MULTIQUIP INC.
by
DENYO MANUFACTURING CO., JAPAN

Your Local Dealer is:



MULTIQUIP INC.

18910 WILMINGTON AVE.
CARSON, CALIFORNIA 90746
800-421-1244 • 310-537-3700
FAX: 310-537-3927
E-mail: mq@multiquip.com
Internet: multiquip.com