

OPERATION AND PARTS MANUAL



GLOBUG SERIES MODEL GB114BS/BP LIGHTING SYSTEM

Revision #2 (11/10/08)

To find the latest revision of this
publication, visit our website at:
www.multiquip.com



THIS MANUAL MUST ACCOMPANY THE EQUIPMENT AT ALL TIMES.

TABLE OF CONTENTS

MQ GLOBUG LIGHTING SYSTEM

Table of Contents.....	2
Parts Ordering Procedures.....	3
Safety Information	4-7
Specifications	8
Dimensions (GB114BS)	9
Dimensions (GB114BP)	10
Floodlight Footcandle Plot	11
General Information.....	12
Components	14-15
Setup	16-17
Operation.....	18
Operation/Shutdown.....	19
Storage	20
Maintenance	21-25
Troubleshooting (Lamp).....	26
Wiring Diagram.....	27
Voltage Measurements.....	28-29
Explanation of Code in Remarks Column.....	30
Suggested Spare Parts	31

COMPONENT DRAWINGS

Nameplate and Decals	32-33
Ballast Assembly S/N G30001 & Below	34-35
Ballast Assembly S/N G30002 & Above	36-37
Fan Blower/Lamp Base Assembly	38-39
Balloon/Lamp Guard Assembly	40-41
Offset Pole Assembly	42-43

Terms and Conditions of Sale — Parts	44
--	----

NOTICE

Specifications and part numbers are subject to change without notice.

PARTS ORDERING PROCEDURES

www.multiquip.com

Ordering parts has never been easier! Choose from three easy options:

Effective:
January 1st, 2006



Order via Internet (Dealers Only):

Order parts on-line using Multiquip's SmartEquip website!

- View Parts Diagrams
- Order Parts
- Print Specification Information



If you have an MQ Account, to obtain a Username and Password, E-mail us at: parts@multiquip.com.

To obtain an MQ Account, contact your District Sales Manager for more information.

Goto www.multiquip.com and click on **Order Parts** to log in and save!

Use the **internet** and qualify for a **5% Discount** on *Standard orders* for all orders which include complete part numbers.*

Note: Discounts Are Subject To Change



Order via Fax (Dealers Only):

All customers are welcome to order parts via Fax.

Domestic (US) Customers dial:
1-800-6-PARTS-7 (800-672-7877)

Fax your order in and qualify for a **2% Discount** on *Standard orders* for all orders which include complete part numbers.*

Note: Discounts Are Subject To Change



Order via Phone: Domestic (US) Dealers Call:
1-800-427-1244

Non-Dealer Customers:

Contact your local Multiquip Dealer for parts or call 800-427-1244 for help in locating a dealer near you.



International Customers should contact their local Multiquip Representatives for Parts Ordering information.

When ordering parts, please supply:

- | | |
|---|--|
| <input type="checkbox"/> Dealer Account Number | <input type="checkbox"/> Specify Preferred Method of Shipment: |
| <input type="checkbox"/> Dealer Name and Address | <input checked="" type="checkbox"/> UPS/Fed Ex <input checked="" type="checkbox"/> DHL |
| <input type="checkbox"/> Shipping Address (if different than billing address) | <input type="checkbox"/> Priority One <input checked="" type="checkbox"/> Truck |
| <input type="checkbox"/> Return Fax Number | <input type="checkbox"/> Ground |
| <input type="checkbox"/> Applicable Model Number | <input type="checkbox"/> Next Day |
| <input type="checkbox"/> Quantity, Part Number and Description of Each Part | <input type="checkbox"/> Second/Third Day |



All orders are treated as *Standard Orders* and will ship the same day if received prior to 3PM PST.

WE ACCEPT ALL MAJOR CREDIT CARDS!



SAFETY INFORMATION

Do not operate or service the equipment before reading the entire manual. Safety precautions should be followed at all times when operating this equipment. Failure to read and understand the safety messages and operating instructions could result in injury to yourself and others.



SAFETY MESSAGES

The four safety messages shown below will inform you about potential hazards that could injure you or others. The safety messages specifically address the level of exposure to the operator and are preceded by one of four words: **DANGER**, **WARNING**, **CAUTION** or **NOTICE**.

SAFETY SYMBOLS

DANGER

Indicates a hazardous situation which, if not avoided, **WILL** result in **DEATH** or **SERIOUS INJURY**.

WARNING

Indicates a hazardous situation which, if not avoided, **COULD** result in **DEATH** or **SERIOUS INJURY**.

CAUTION

Indicates a hazardous situation which, if not avoided, **COULD** result in **MINOR** or **MODERATE INJURY**.

NOTICE

Addresses practices not related to personal injury.

Potential hazards associated with the operation of this equipment will be referenced with hazard symbols which may appear throughout this manual in conjunction with safety messages.

Symbol	Safety Hazard
	Burn hazards
	Electric shock hazards

GENERAL SAFETY

CAUTION

- **NEVER** operate this equipment without proper protective clothing, shatterproof glasses, respiratory protection, hearing protection, steel-toed boots and other protective devices required by the job or city and state regulations.



- **NEVER** operate this equipment when not feeling well due to fatigue, illness or when under medication.
- **NEVER** operate this equipment under the influence of drugs or alcohol.



NOTICE

- This equipment should only be operated by trained and qualified personnel 18 years of age and older.
- Whenever necessary, replace nameplate, operation and safety decals when they become difficult read.
- Manufacturer does not assume responsibility for any accident due to equipment modifications. Unauthorized equipment modification will void all warranties.
- **NEVER** use accessories or attachments that are not recommended by Multiquip for this equipment. Damage to the equipment and/or injury to user may result.
- **ALWAYS** know the location of the nearest **fire extinguisher**.
- **ALWAYS** know the location of the nearest **first aid kit**.
- **ALWAYS** know the location of the nearest phone or **keep a phone on the job site**. Also, know the phone numbers of the nearest **ambulance**, **doctor** and **fire department**. This information will be invaluable in the case of an emergency.



SAFETY INFORMATION

LIGHTING SYSTEM SAFETY

DANGER

- **NEVER** use lighting system in **rain, snow** or areas of high humidity that could generate electrical storms.



WARNING

- **NEVER** disconnect any **emergency or safety devices**. These devices are intended for operator safety. Disconnection of these devices can cause **severe injury, bodily harm or even death**. Disconnection of any of these devices will void all warranties.

CAUTION

- **NEVER** attempt service on a running machine.

NOTICE

- To prevent the lighting system from overturning, **NEVER** use in winds that exceed 22mph (10 m/s).
- The lighting system should only be used in temperatures between 23° to 104°F (-5° to 40° C). Failure to comply with these operating parameters could cause the lamp to malfunction and shorten the ballast life.
- **ALWAYS** keep the lighting system in proper running condition.
- Fix damage to lighting system and replace any broken parts immediately.
- **ALWAYS** store equipment properly when it is not being used. Equipment should be stored in a clean, dry location out of the reach of children and unauthorized personnel.

LAMP SAFETY

WARNING

- **NEVER** attempt to replace lamp with the power on. Always unplug the power cord from the generator or power source when changing the lamp.
- **ALWAYS** allow a sufficient amount of time for the lamp to **cool** before changing. The possibility exists of severe burns.

CAUTION

- **NEVER** use force when installing the lamp. Excessive force could cause the lamp to break, causing bodily harm.

NOTICE

- **NEVER** leave any grease or oil residue on lamp surface when replacing or removing lamp. This can create hot spots, reducing the service life of the lamp.
- **ALWAYS** make sure lamp surface is clean and dry.
- **ALWAYS** replace with MQ recommended type lamp. See parts section of this manual.
- If applicable, **ALWAYS** make sure the lamp guard is installed correctly. **NEVER** deform the lamp guard.
- **NEVER** unplug the lamp's AC power cable during operation.
- **ALWAYS** have a **trained technician** to install and remove lamp or replace any damaged fixture wiring.

BALLOON SAFETY

WARNING

- To prevent serious burns, **NEVER** touch or unzip the balloon envelope when the lamp is on.



CAUTION

- **ALWAYS** keep the balloon away from sharp objects and excessive amounts of heat.

NOTICE

- To prevent balloon deformation, **NEVER** use lighting system in strong winds.
- **DO NOT** place the balloon inside its protective cover until the lamp has had a sufficient amount of time to cool down. This will prevent the balloon's nylon cover from being burned (touching the lamp surface).
- **ALWAYS** place the balloon inside its protective cover after each use. This will prolong the life of the balloon material, keeping it protected from harsh environmental elements.
- Replace balloon immediately if damaged. A damaged balloon will not inflate properly, and may become more damaged by touching the hot lamp surface.
- **DO NOT** use excessive force when zipping and unzipping the balloon. Be gentle with the zipper mechanism. If the zipper is broken, the balloon will become unusable.

SAFETY INFORMATION

GENERATOR SAFETY

If using a generator to power lighting system, refer to applicable generator manual safety information section.



ELECTRICAL SAFETY

DANGER

- Lighting system is equipped with a ground pin on the power plug. For your protection, **ALWAYS** complete the grounding path. **NEVER** insert the AC power plug into a 2-prong receptacle to operate lighting system.

When applying power to the lighting system, **ALWAYS** connect the AC power plug to a 3-prong receptacle that is grounded. The possibility exists of **electrical shock, electrocution and even death** if the lighting system is not grounded.

- **NEVER** operate lighting system or handle any electrical equipment while standing in water, while barefoot, while hands are wet or in the rain. A dangerous **electrical shock** could occur, causing **severe bodily harm or even death**.



- **ALWAYS** make sure the area above the lighting system is open and clear of overhead power lines and other obstructions. Contact with overhead power lines or other obstructions could result in equipment damage, **electrical shock, electrocution and even death**.

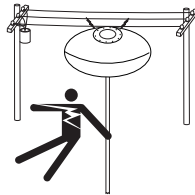

Power Cord/Cable Safety

DANGER

- **NEVER** let power cords or cables **lay in water**.
- **NEVER** use **damaged** or **worn** cables or cords. Inspect for cuts in the insulation
- **NEVER** grab or touch a live power cord or cable with **wet hands**. The possibility exists of **electrical shock, electrocution or death**.
- Make sure power cables are securely connected. Incorrect connections may cause **electrical shock** and damage to the lighting system.

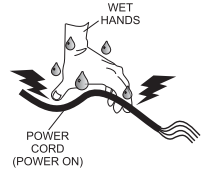

NOTICE

- **ALWAYS** make certain that proper power or extension cord has been selected for the job. See Cable Selection Chart in this manual.

SAFETY INFORMATION

LOADING AND UNLOADING

If lighting system is equipped with a transport lifting hook, refer to the following safety information.

CAUTION

- Before lifting, make sure that lighting system parts are not damaged and screws are not loosened or lost.
- **ALWAYS** make sure crane or lifting device has been properly secured to lifting hook of the equipment.
- **NEVER** lift the equipment while lighting system is running.
- Make sure the mast is completely lowered before lifting the lighting system.
- Use adequate lifting cable (wire or rope) of sufficient strength.
- Use one point suspension hook and lift straight upwards.

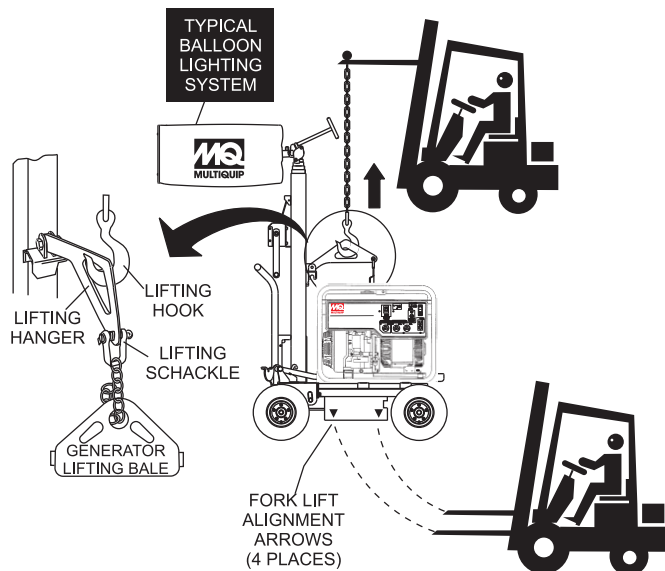

- Never allow any person or animal to stand underneath the equipment while lifting.
- **DO NOT** lift machine to unnecessary heights.

TRANSPORTING SAFETY

NOTICE

- When transporting the lighting system, if applicable, always place in **stow position** and place mast in its carrying case.
- **ALWAYS** remove balloon/lamp assembly from the mast when transporting lighting system. This will prevent damage to the bulb due to vibration.
- **NEVER** leave the balloon/lamp exposed during transport. Exposure to excess wind or rain could damage the balloon's nylon cover.
- **ALWAYS** place balloon inside its protective cover during transport. Be sure the cover is secured tightly around the balloon/lamp assembly.

SPECIFICATIONS

Table 1. Specifications	
GloBug Lighting System	
Model	GB114BS/GB114BP
Input Voltage	120 VAC
Ballast	Magnetic Ballast 60 Hz
Frequency	60 Hz Single-Phase
Max. Current	9.5 Amps
Lamp	
Lamp Type	1000 Watt Metal Halide
Lumens	112,000
Light Coverage (360°)	150 ft. (45.72 meters)
Surface Temperature (Longitudinal)	476.6°F (247°C) Max.
Surface Temperature (Transversal)	417.2°F (214°C) Max.
Fan Motor	
Balloon Fan Motor	115 VAC, 60 Hz
Max. Current	.360 Amps
Pressure	31.26 PSI (215.6 kPA)
Balloon	
Diameter	47.16 in. (1,200 mm)
Material	Heat Resistant Nylon
Heat Resisting Temperature	320 ~ 356°F (160 ~ 180°C)
Melting Temperature	500°F (260°C)
Internal Temperature of Balloon	126°F (52°C) Average
Water Resistance	1,500 mm H ₂ O
Weight	
GB114BS	83 lb. (38 kg)
GB114BP	61 lb. (28 kg)

DIMENSIONS (GB114BS)

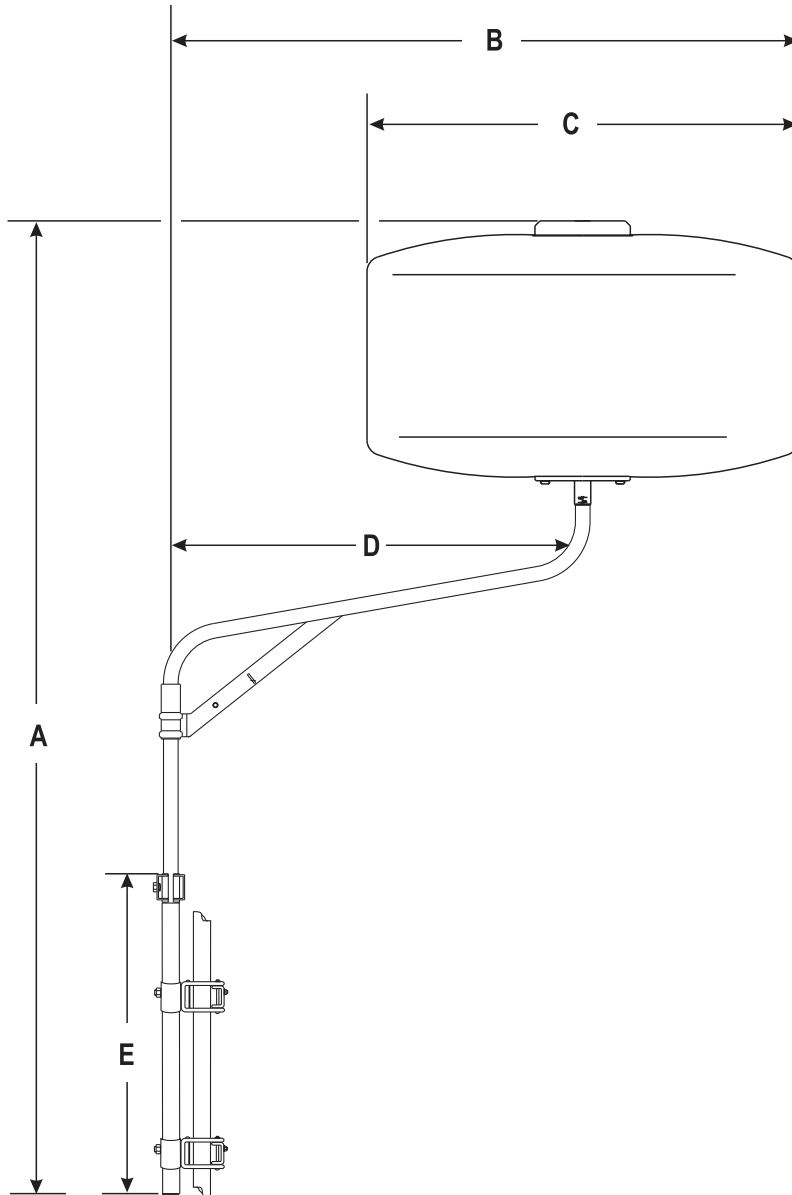

Figure 1. Dimensions (GB114BS)

Table 2. Dimensions			
Reference Letter	Dimension in. (mm.)	Reference Letter	Dimension in. (mm.)
A	88.0 -108.0 in. (2,230 - 2,730 mm.)	D	35.00 in. (900 mm.)
B	59 in. (1,500 mm.)	E	35.00 in. (900 mm.)
C	47.16 in. (1,200 mm.)		

DIMENSIONS (GB114BP)

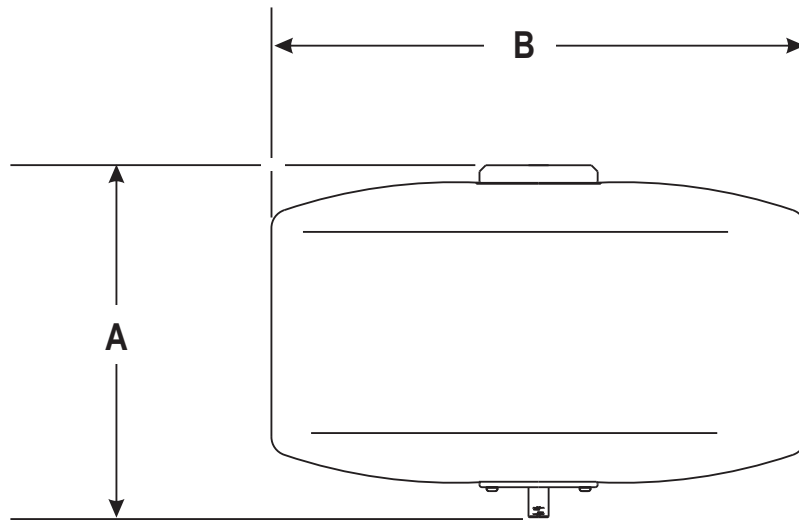
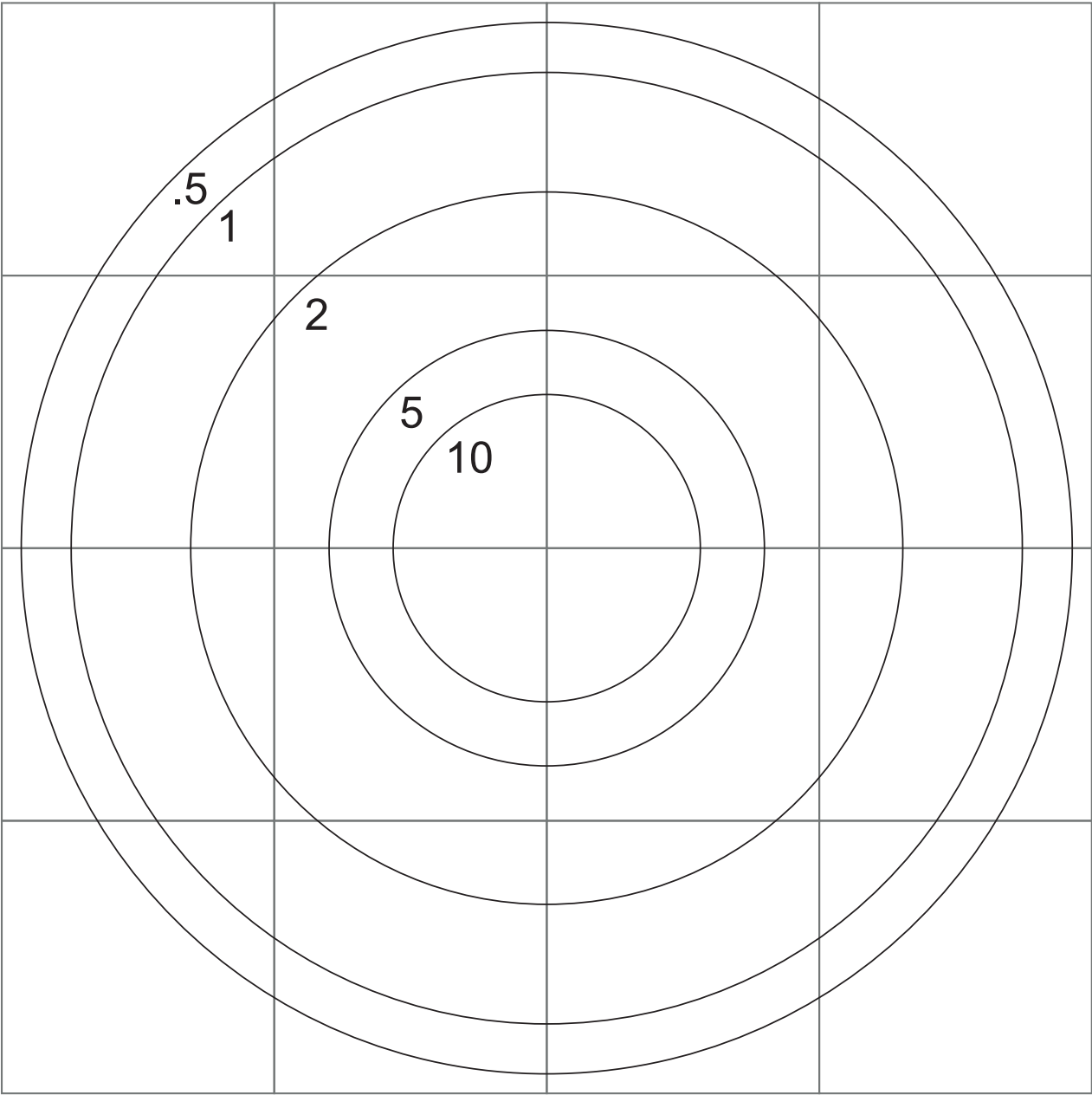

Figure 2. Dimensions (GB114BP)

Table 3. Dimensions	
Reference Letter	Dimension in. (mm.)
A	28.00 in. (712 mm.)
B	47.16 in. (1,200 mm.)

FOOTCANDLE PLOT

360° Coverage



Values listed as footcandles

Scale: Grid = 50 ft. (15.25 meters)

Figure 3. Floodlight Footcandle Plot (BAL-115 Drum Shaped)

GENERAL INFORMATION

The Multiquip GloBug GB114BS, and GB114BP are general purpose portable glare-free lighting systems. Typical applications for these types of lighting systems include construction sites, emergency road crews and backyard parties.

BALLOON ENVELOPES

The GloBug lighting system can be configured with a variety of balloon envelopes (canopy). Please contact the MQ sales department for the balloon of your choice. The GloBug GB114BS and GB114BP shipped from the factory with the drum type balloon.

LIGHTING

Multiquip's GloBug lighting system is comprised of one "Metal Halide" 1000-watt lamp. This lamp has an output of 112,000 lumens. Typical lighting coverage is in excess 150 ft. (46 meters) in a 360 degree pattern.

POWER

These GloBug lighting systems are powered by a portable ballast that can be hand carried. The input power requirements for operating the lighting system is 120 VAC, 60 Hz @ 9.5 amps

GB114BS

The GB114BS lighting system (offset pole) is designed to be attached to a external piece of a equipment such as a paver (Figure 4). This system is equally easy to assemble. Simply attach the supplied support clamps to an external pole or support and you are ready.

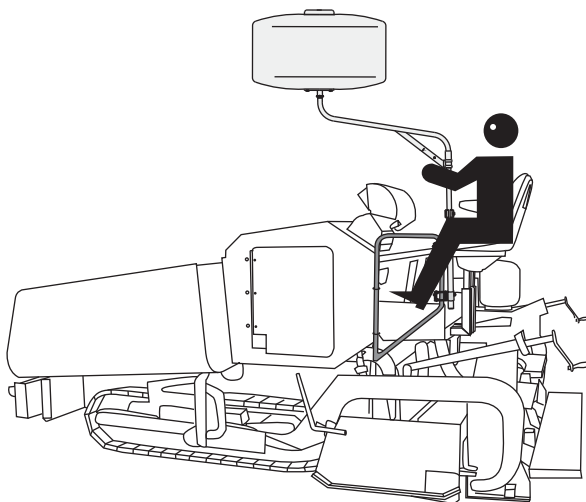

Figure 4. GB114BS Offset Pole (Paver)

GB114BP

When only a complete lamp assembly is required please order Model GB114BP. This model number includes the lamp, protective guard, balloon protective covering and all other components that make up the lamp assembly.

TRANSPORT

The GB114 lighting systems can be transported quite easily. The GB114BP consists of a balloon/lamp, power cable and a ballast, and it has a combined weight of 61 lbs (28 kg). The GB114BS consists a balloon/lamp, power cable, ballast and offset pole, and it has a combined weight of 83 lbs (38 kg).

For ease of service or transport, the lamp assembly is equipped with a quick-disconnect connector that allows the lamp fixture to be removed quickly. This feature is extremely useful during transport of the lighting system. It is always best to remove the lamp and pack it safely so it will not be damaged.

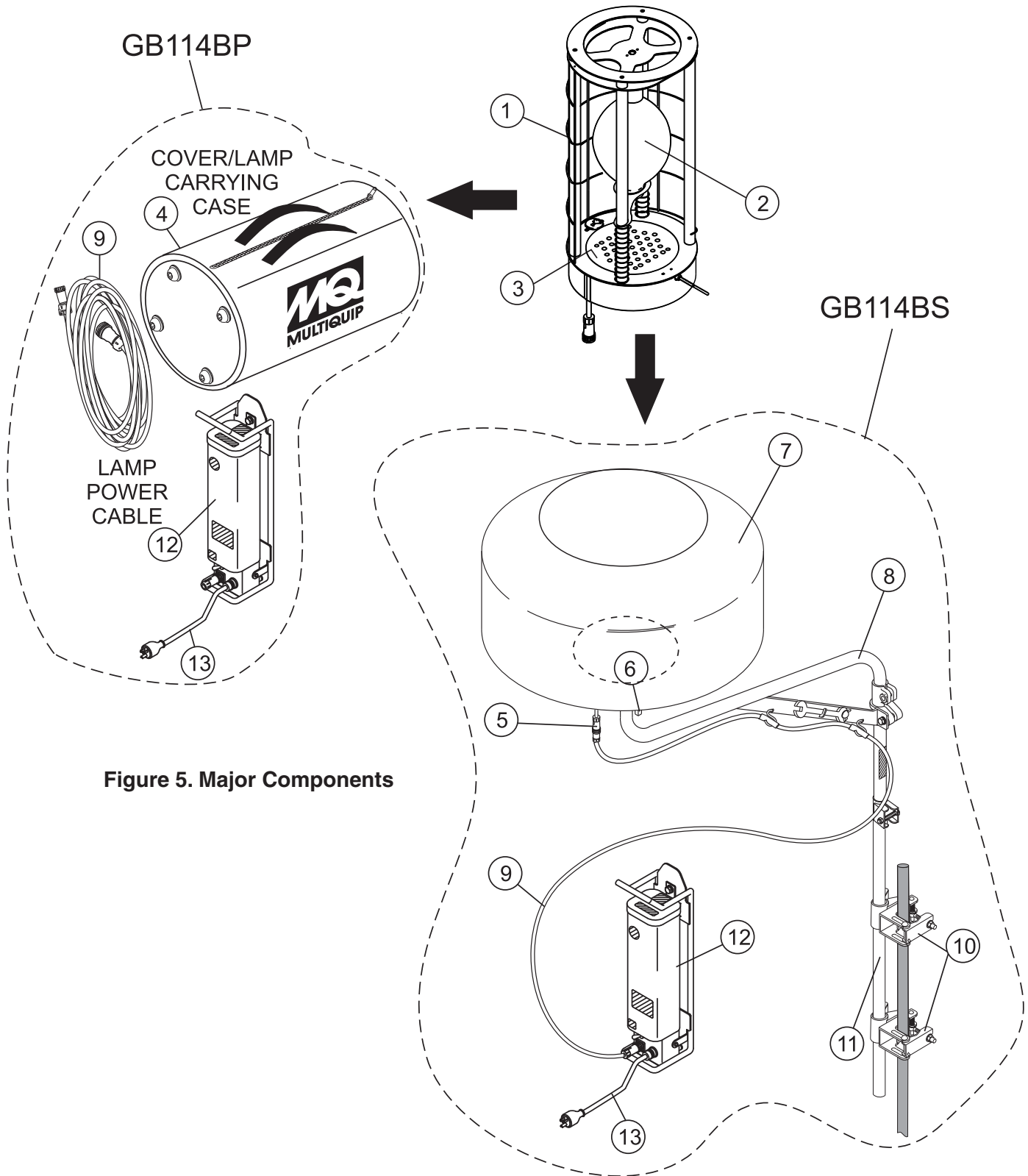

Figure 5. Major Components

COMPONENTS

Figure 5 shows the location of the components for the GloBug lighting system. The function of each component is described below:

1. **Lamp Guard** — This guard (cage) protects the lamp from being hit by objects.
2. **Lamp** — 1000 watt metal-halide type lamp. Replace only with MQ recommended type lamp. Always allow a sufficient amount of time for the lamp to cool down before changing.
3. **Fan Motor (Blower)** — This electric motor is responsible for inflating the balloon. It will supply a pressure of 31.26 psi /215.6 kPA. Please note that the balloon will begin to inflate as soon as power is applied to the lighting system.
4. **Balloon Cover/Carrying Case** — When zipped, this protective cover acts like a carrying case. The complete lamp assembly is enclosed within the cover-carrying case. Allow a sufficient amount of time for the lamp to cool down before covering balloon. The possibility exists of the balloon getting burned.
5. **Lamp Assembly Connector** — Quick-disconnect cable. Provides AC power to lamp assembly.
6. **T-Handle Bolt Lock** — Always tighten this lock to hold the lamp/balloon securely in place.
7. **Balloon** — This balloon is made of heat-resistant nylon, with a diameter of 47 inches (1200 mm).
8. **Offset Pole** — Supports lamp assembly when attached to the main mast. Included with the offset pole is a 17/19 mm wrench.
9. **Lamp Power Cable (Output)** — Connect this cable between the ballast receptacle and the lamp assembly connector.
10. **Pole Clamps** — Attach these clamps (2) to the main pole and external support pole. Always tighten both clamps securely to prevent slippage of the light assembly.
11. **Main Pole** — Used in conjunction with the offset pole to support the lamp assembly.
12. **Ballast** — Power source for lamp. Input power requirements are 120 VAC, 60 Hz @9.5 amps.
13. **Ballast AC Power Cable (Input)** — Connect this cable to a 120 VAC, 60 Hz power source.

NOTICE

The pole clamp assembly used in this setup procedure is a dual type clamp. One side of the clamp is for the attachment of the main pole of the lighting system. The other side of the clamp is used for the attachment of a support pole that is usually connected to a piece of equipment such as a paver.

POLE SETUP

Refer to Figure 6 for the following procedure.

1. Remove the offset pole (B) from the shipping container.
2. Attached to the offset pole is a 17/19 mm open-end wrench (C). Remove the wingnut (D) securing the wrench to the offset pole and remove wrench.
3. Reinsert wingnut and washer back into offset pole so they will not get lost or misplaced.
4. Remove the two pole clamp assemblies (A) from the shipping container. Attach one pole clamp assembly (E) to the main pole (F) about 3 inches (76.2 mm) down from the main pole extension clamp. Using supplied 19 mm wrench, tighten locknut on the pole clamp assembly securely.
5. Attach the other pole clamp assembly (G) to the main pole (F) about 7.0 in. (140 mm.) down from the previous attached pole clamp assembly (E). Using the 19 mm wrench, tighten locknut on the pole clamp assembly securely.
6. To attach main pole (F) to equipment support pole (I), swing open adjustable tension plate (H) on clamp so that it can accommodate the diameter of the equipment support pole. Insert equipment support pole (I) through the two equipment support pole clamp assemblies as shown in Figure 6.
7. Once the equipment support pole (I) has been seated properly, move adjustment bolt and locknut (J) into locking position. Use the supplied 17 mm wrench, to tighten locknuts (J) on both clamps securely.
8. Place offset pole (B) with adapter clamp (K) on top of adjustable extension pole (L). Make sure that offset pole has been seated correctly.

9. Using 17 mm wrench, tighten both bolts (M) on the offset adapter clamp (K) securely.
10. Place lamp assembly (N) onto offset pole (B). Tighten T-handle bolt (O) securely.

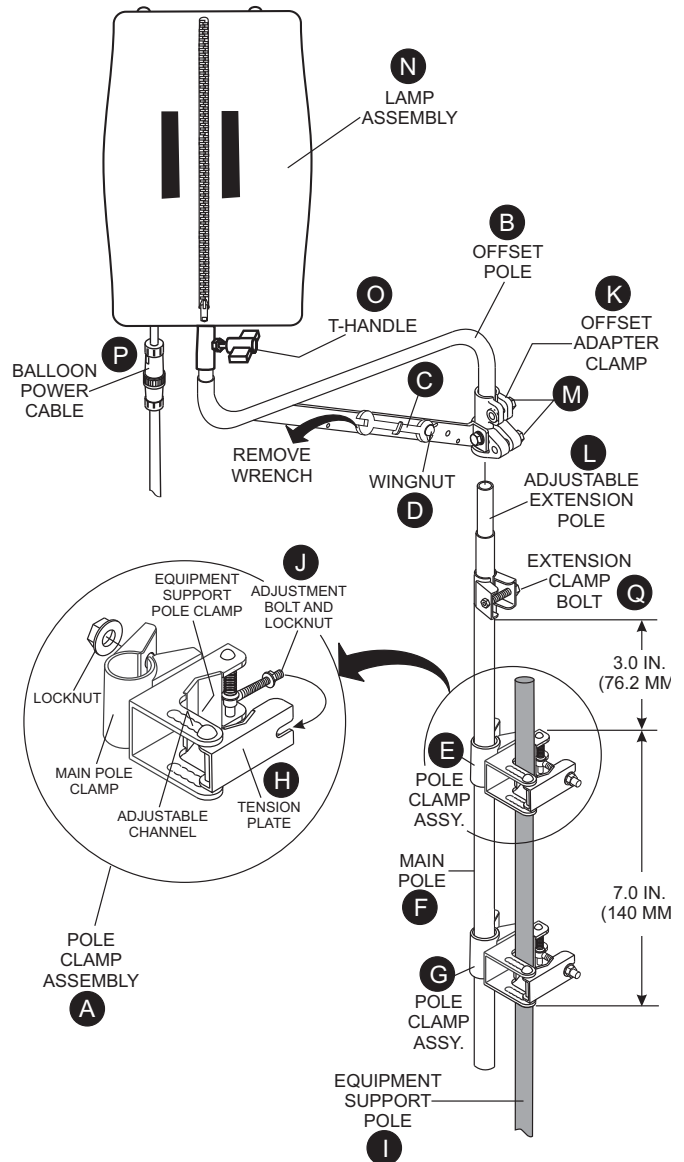

Figure 6. Offset Pole Assembly

REMOVING THE PROTECTIVE COVERING

1. Expose the balloon by pulling down on the velcro tab and unzip the protective cover as shown in Figure 7.

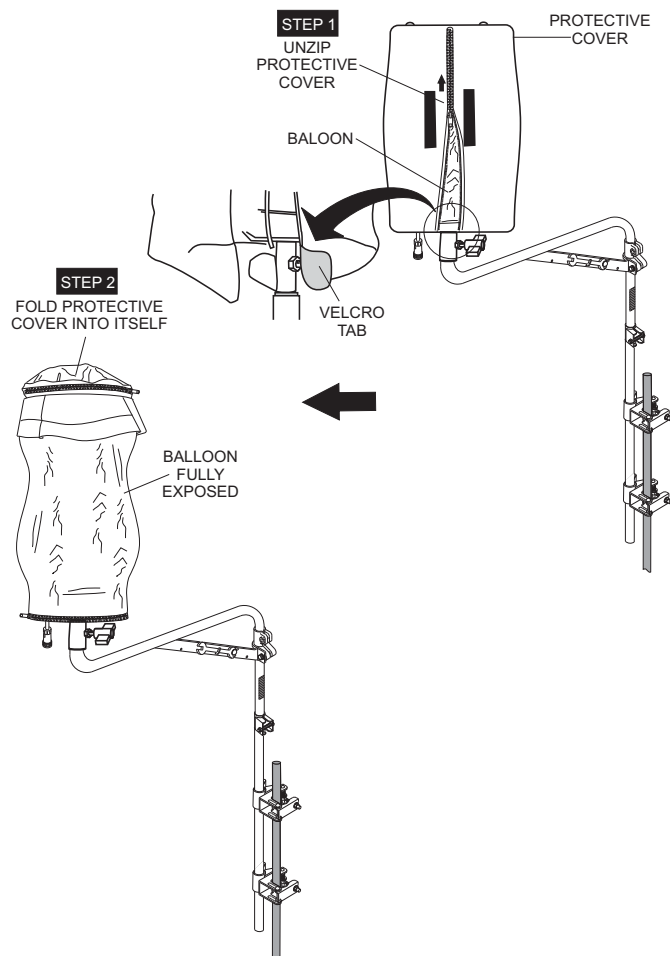

Figure 7. Folding Protective Cover

CONNECTING POWER CABLE

1. Connect 16.4 ft. (5 meters) lamp power cable (Figure 8) to the balloon power cable.

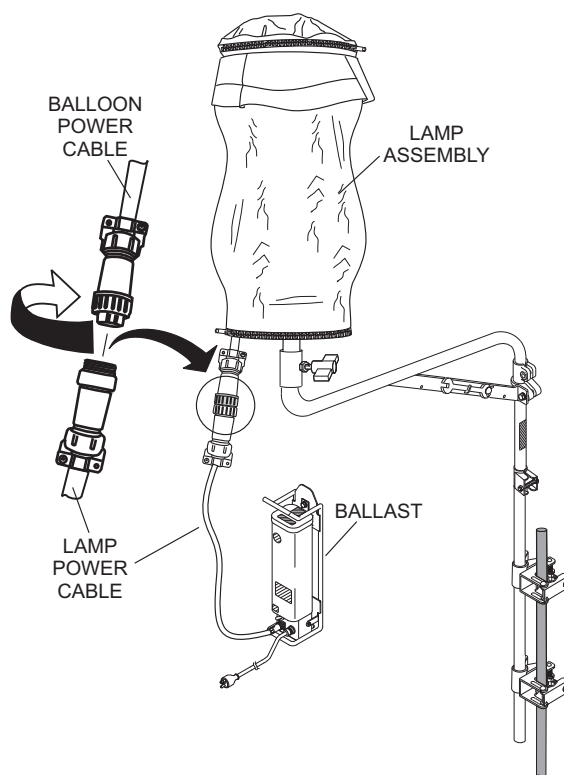

Figure 8. Connecting Lamp Power Cable

2. Attach both S-type hooks (Figure 9) on the lamp power cable into the cable support holes on the offset pole.

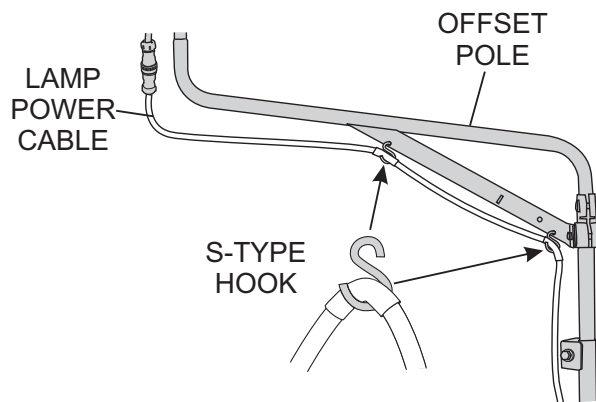
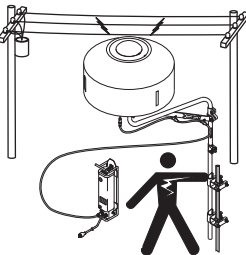

Figure 9. Attachment of S-Hooks

RAISING THE EXTENSION POLE

1. Before raising the extension pole, make sure the T-handle bolt lock (Figure 6-O) is securely tightened. This will prevent the balloon/lamp assembly from falling off. In addition make sure that the lamp power cable is connected to the mating end of the power source cable.
2. Raise extension pole (Figure 6-L) to desired height. Watch out for any overhead obstructions.
3. Using 19 mm wrench, tighten extension clamp bolt (Figure 6-Q) securely. Keep wrench in a safe place where it will not get lost.

! DANGER



ALWAYS make sure the area above the lighting system is open and clear of overhead power lines and other obstructions. Contact with overhead power lines or other obstructions could result in equipment damage, **Serious Injury or Death!**

! DANGER



When raising the extension pole, **ALWAYS** be on the lookout for overhead obstructions such as high voltage power lines. The possibility exists of electrocution, even death! if the lighting system comes in contact with high voltage power lines.

APPLYING POWER

1. Make sure the power ON/OFF switch (Figure 10) located near the bottom of the ballast is in the OFF position.

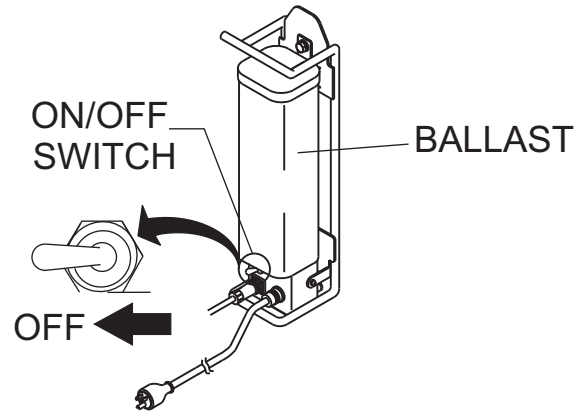

Figure 10. Power OFF/ON Switch (Off Position)

2. If using a power source (Figure 11) other than a portable generator, plug the AC power cord from the ballast into a 120 VAC, 60 Hz receptacle that is protected by a at least a 15 amp circuit breaker.

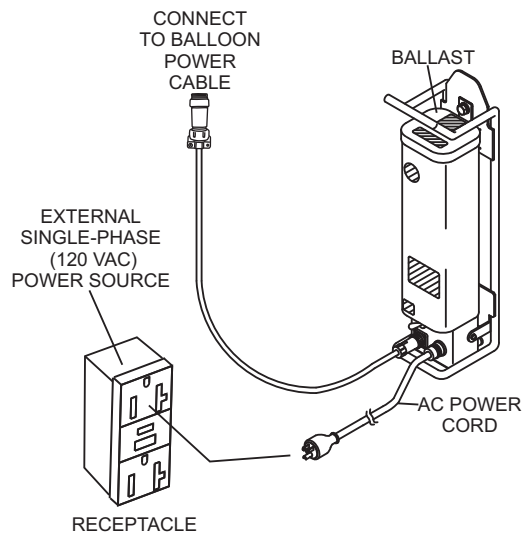

Figure 11. Applying 120 VAC Power

NOTICE

If using a portable generator, start the generator as referenced in the "Start-up Section" of the supplied generator manual.

Once the generator has started, plug the AC power cord from the ballast (Figure 11) into a GFCI receptacle on the generator.

NOTICE

ALWAYS Make sure ballast is securely mounted to a surface where it will not move, slip or fall. This will prevent severe damage to the ballast.

3. Place the ON/OFF switch (Figure 12) on the ballast in the ON position.

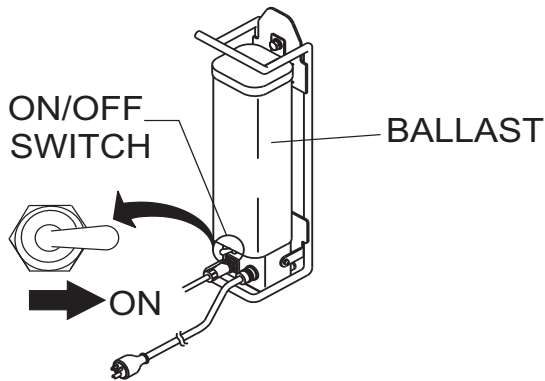

Figure 12. Ballast On/Off Switch (On Position)

4. Notice that the balloon envelope will begin to deploy as soon as power is applied.
5. The lamp should now be on. If the lamp is not on, check all connections and repeat steps 1 thru 4. If the lamp still does not come on, contact your nearest MQ service center.
6. The lighting system is now ready for use.

SHUTDOWN

1. Place the ON/OFF switch on the ballast to the OFF position. The balloon should begin to deflate and the lamp turns off.
2. If using a portable generator, shut-down the generator as referenced in the "Shutdown Section" of the supplied generator manual. ALWAYS place the main circuit breaker in the OFF position before turning off the generator.
3. If using a power source other than an AC generator, disconnect the ballast AC power cable from the power source.

NOTICE

Allow a sufficient amount of time (15-20 minutes) for the lamp to cool down. The possibility exists of the balloon getting burned (touching the lamp).

LOWERING THE EXTENSION POLE

1. Using the supplied 19 mm wrench, loosen extension clamp bolt (Figure 6-Q).
2. Carefully pull down on the adjustable extension pole (Figure 6-L) and lower lamp assembly.
3. Remove wingnut (Figure 6-D) from offset pole (Figure 6B) and insert wrench into wrench holder. Reinsert wingnut and tighten.

REMOVING LAMP ASSEMBLY

1. Disconnect balloon power cable (Figure 13) from the lamp power cable. Place lamp power cable in a safe place where it will not get damage or lost..

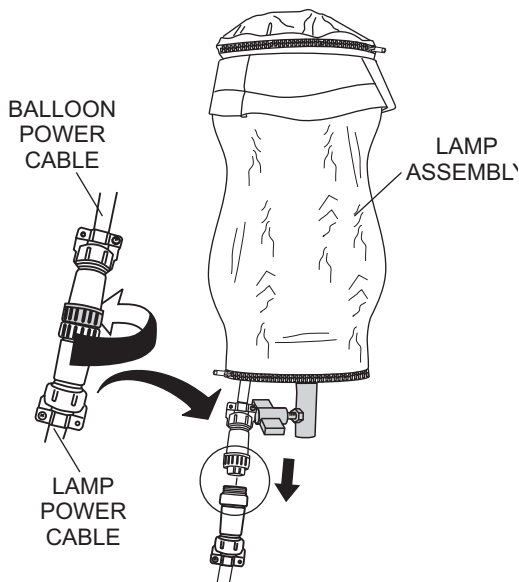

Figure 13. Disconnecting Power Cables

2. Remove both S-type hooks (Figure 9) on the lamp power cable from the cable support holes on the offset pole.
3. Unzip the zipper on the protective cover (Figure 14), and pull down cover over balloon/lamp assembly.

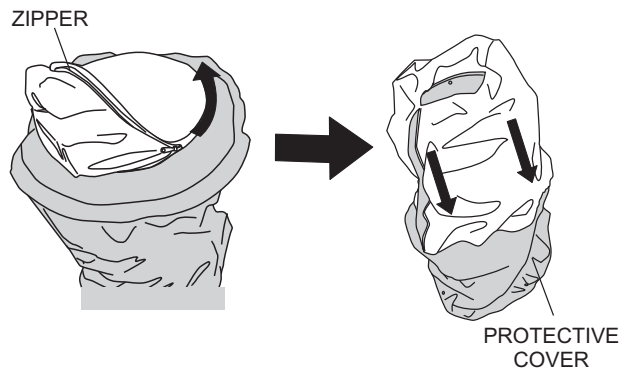

Figure 14. Unzipping the Protective Cover

4. Fully zip protective cover and fold velcro tab in place.

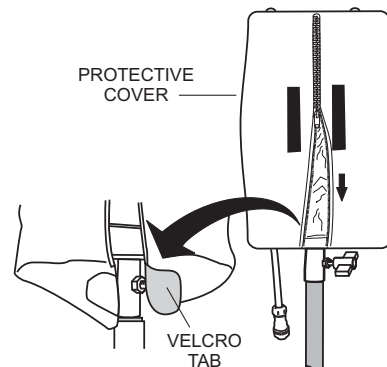

Figure 15. Zipping the Protective Cover

5. Loosen T-handle bolt (Figure 6-O) by turning counterclockwise and remove lamp assembly (Figure 6-N) from offset pole.
6. Store lamp assembly enclosed within its protective cover (Figure 16) in a safe location where it will not be damaged.



Figure 16. Storing Lamp Assembly

CAUTION



Before performing any maintenance procedures, be sure to **READ** the lamp, balloon, and general safety guidelines in this manual. Failure to **read** and **understand** these safety guidelines could cause severe equipment damage and bodily harm.

REMOVING THE LAMP ASSEMBLY

1. Allow lamp (Figure 17) 15-20 minutes to cool before changing.

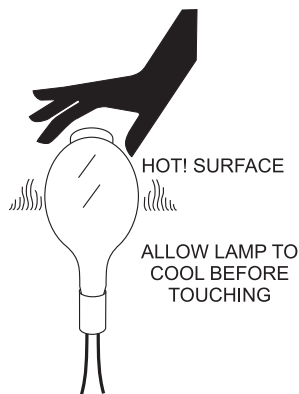

Figure 17. Hot Lamp Surface

2. If lamp assembly is attached to offset pole, loosen T-handle knob (Figure 18) that secures the lamp to the offset pole.

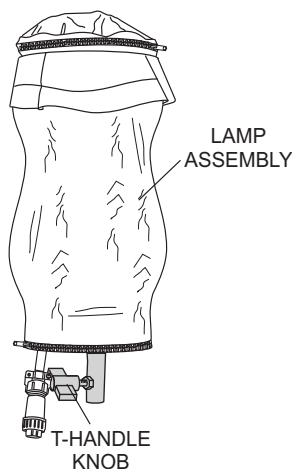

Figure 18. T-Handle Knob

3. Lift lamp assembly from offset pole, and place on a suitable work bench that is free of dirt, and sharp objects that could damage the balloon.

CAUTION



DO NOT use excessive force when zipping or unzipping the balloon. The possibility exists of the zipper tearing, which would make the balloon unusable.

REMOVING THE BALLOON

1. Expose the balloon (Figure 19) by pulling down on the velcro tabs and unzip the protective cover as shown in Figure 7. Next, fold the protective cover into itself and zip

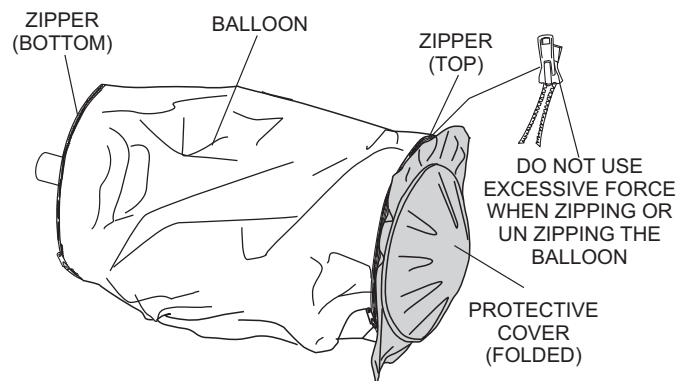

Figure 19. Exposing the Balloon

2. Unzip the zipper (Figure 19) at the bottom of the balloon and roll the balloon envelope upwards to expose the lamp (Figure 20). Remove the lamp guard to gain access to the lamp. **DO NOT** use excessive force when unzipping the balloon.

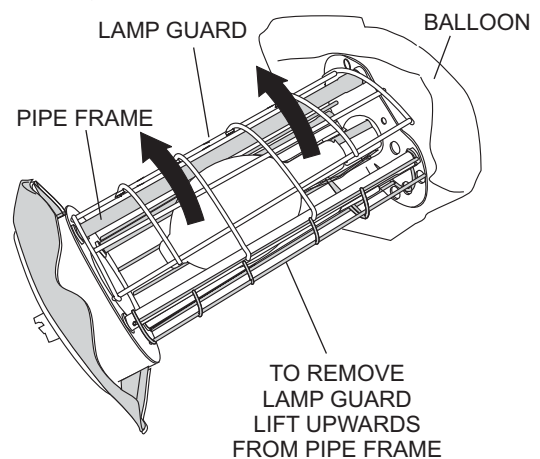

Figure 20. Removing the Lamp Guard

3. Push down and hold the lamp holder (spring loaded) away from the lamp (Figure 21). Unscrew the lamp (turn counterclockwise) from the lamp socket.

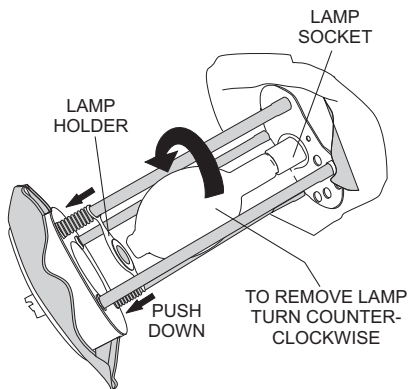

Figure 21. Removing the Lamp

INSTALLING A NEW LAMP

1. When installing a new lamp (Figure 22) use only MQ recommended type lamp. See parts section of this manual. Failure to use correct type lamp could adversely affect lighting capability and may cause damage to the equipment.
2. Push down and hold the lamp holder (spring loaded) away from the lamp. Screw the lamp (turn clockwise) into the lamp socket. Gently place the lamp holder firmly over the top of the lamp. This will prevent the lamp from touching the lamp guard or pipe frame.

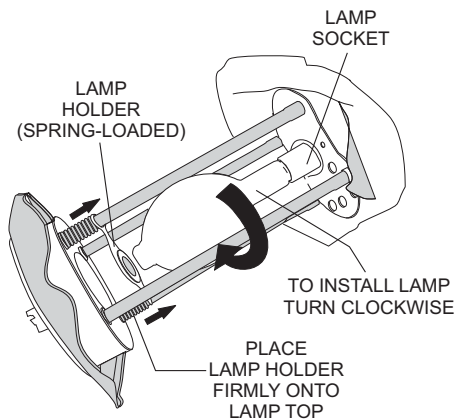

Figure 22. Installing the Lamp

RE-INSTALLING THE LAMP/BALLOON ASSEMBLY

1. Reinstall the lamp guard (Figure 23). Be careful not to install the lamp guard in the wrong direction.

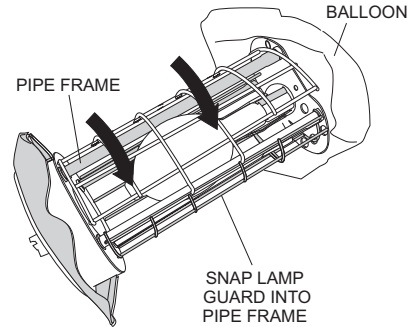

Figure 23. Installing the Lamp Guard

2. Zip up the zipper at the bottom (Figure 19) of the balloon and pull down the balloon envelope to cover the lamp
3. Place the lamp/balloon assembly back onto the mast.
4. Tighten the T-Handle Bolt Lock to secure the lamp to the mast.
5. Reinstall the protective cover over the balloon/lamp assembly. Be sure to fold the velcro tabs.
6. Reconnect the power cables.

REPLACING THE BALLOON

1. Follow the procedures as outlined in the "Removing the Balloon Lamp" assembly section.
2. Unzip the zipper at the bottom and top of the balloon. Slide the balloon over the top of the lamp guard as shown in Figure 24.

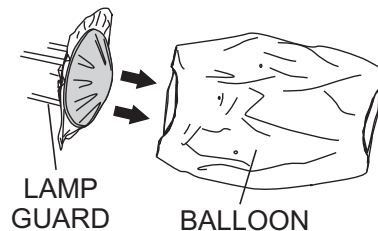

Figure 24. Removing the Balloon

3. Slide the new balloon over the top of the lamp guard as shown in Figure 25. Zip up the zipper at the bottom and top of the balloon.

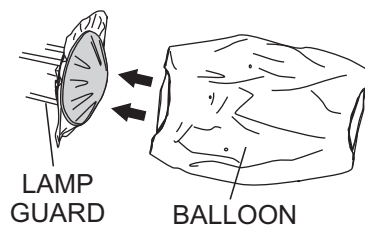



Figure 25. Removing the Balloon

CAUTION

DO NOT replace filter immediately, allow a sufficient amount of time for the lamp assembly to cool down before changing filter



FILTER REPLACEMENT

1. Remove the balloon as described in the "Removing the Lamp/Balloon" section.
2. Disconnect the lamp power cable (Figure 5).
3. Rotate the balloon/lamp base assembly so that the filter is facing upwards. See Figure 26.

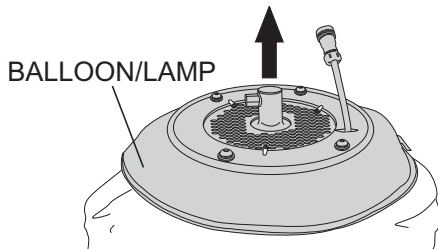

Figure 26. Balloon/Lamp Placement

4. Turn the three locking tabs (Figure 27) inward to release the plate. Remove plate and filter.

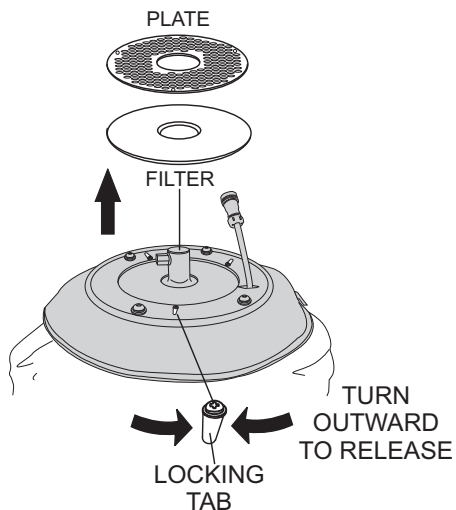

Figure 27. Filter Removal

5. Install a new filter over the brace as shown in Figure 28. Be sure to align the cut of the filter over the brace.

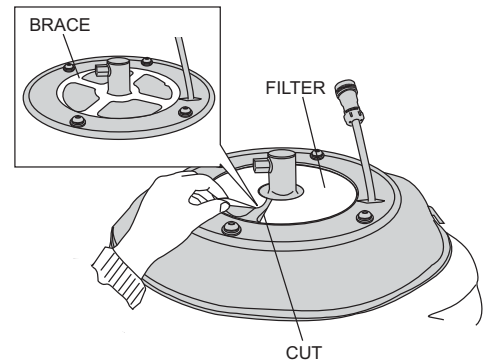

Figure 28. Filter Placement

CAUTION

When placing the filter element, always align the cut of the filter on top of the brace. This will keep the filter from being dislodged and getting damaged.

6. Turn the three retaining tabs (Figure 29) outward so that they touch the lamp base.

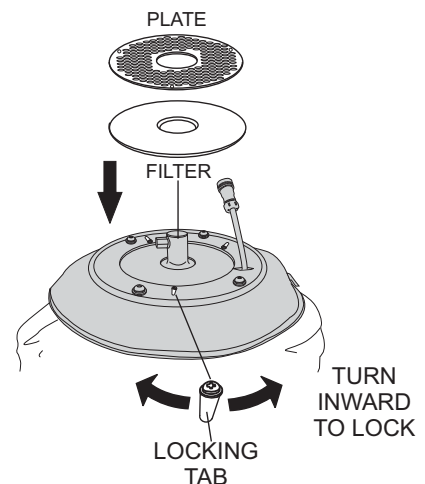

Figure 29. Filter/Plate Install

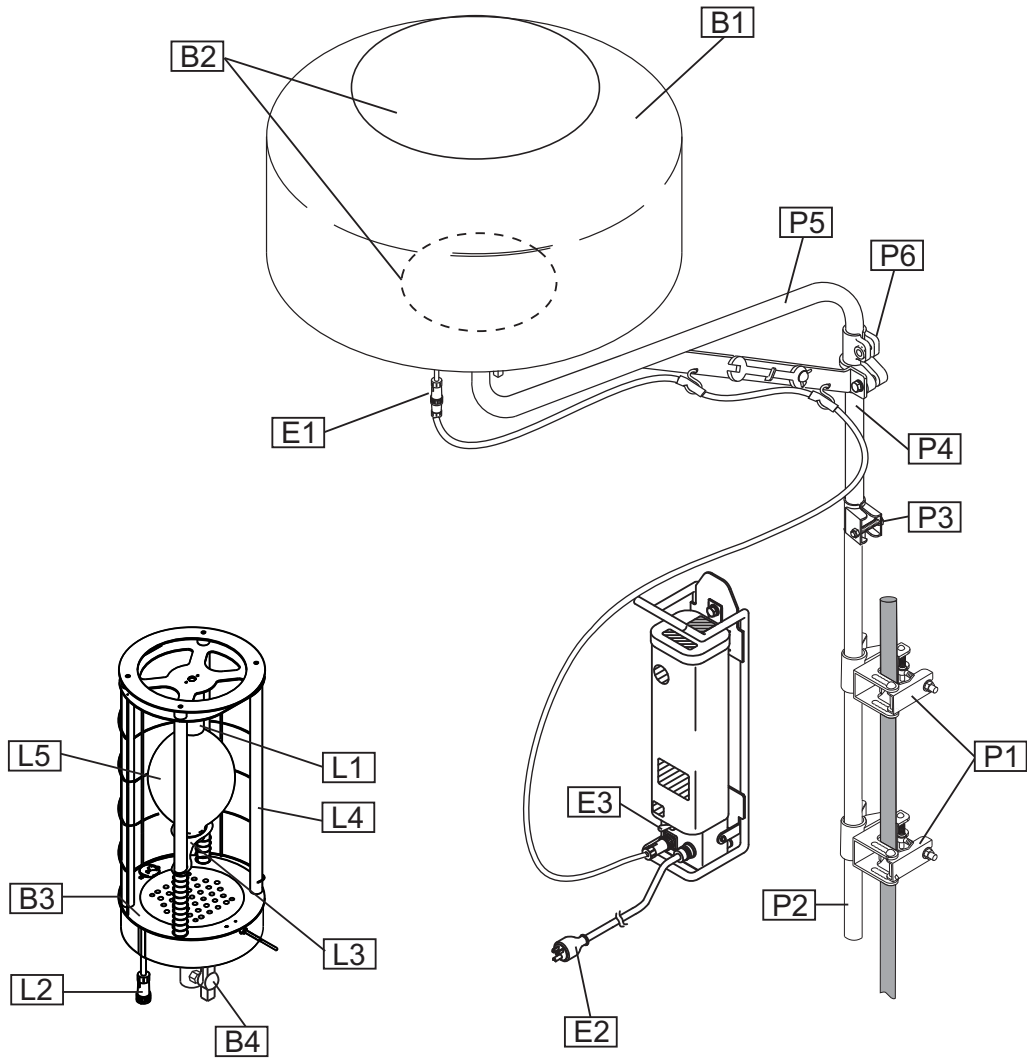

Figure 30. Maintenance Check Points

For a prolonged life cycle an extended quality follow the recommended GloBug lighting system service guidelines as referenced in Figure 30 and Table 4.

Table 4. Periodic Check and Maintenance					
Figure	Part	Check Item	Solution	Frequency	
Lamp	L1	Lamp (Base)	Lamp base loose?	Screw in securely	❖
	L2	Connector	Cable disconnected or loose?	Connect securely	❖
	L3	Lamp Holder	Lamp holder loose?	Replace	❖
	L4	Pipe Frame	Frame pipe skewed?	Replace	❖
	L5	Lamp	Defective lamp?	Replace	■
Balloon	B1	Balloon (Envelope)	Defective or dirty?	Replace	❖
	B2	Zipper	Broken?	Replace	❖
	B3	Fan Motor (Blower)	Not working properly?	Repair or replace	❖
	B4	T-Handle bolt (Balloon)	Broken?	Replace	❖
Electric	E1	Power Cable	Defective or worn cable?	Replace	❖
	E2	Plug	Damaged?	Replace	❖
	E3	Lamp Switch	Damaged or not working properly?	Replace	❖
Pole	P1	Clamp	Broken?	Repalce	❖
	P2	Support pipe	Support pipe bent or damaged?	Replace	❖
	P3	Support bolt	Support bolt loose?	Tighten securely	❖
	P4	Straight pole	Straight pole bent or damaged?	Repalce	❖
	P5	Offset pole	Offset pole bent or damaged?	Replace	❖
	P6	Offselt bolt	Offset bolt loose?	Tighten securely	❖
❖ - Daily Check ■ - Every 20 Hours					

TROUBLESHOOTING (LAMP)

Practically all breakdowns can be prevented by proper handling and maintenance inspections, but in the event of a breakdown, please take a remedial action following the diagnosis based on the Lamp Troubleshooting (Table 5) information shown below. If the problem cannot be remedied, please leave the unit just as it is and consult or company's service department.

Table 5. Lamp Troubleshooting

Symptom	Possible Problem	Solution
Lamp does not light	Is AC power turned on?	Turn on AC power
	Is AC power cable connected?	Connect AC power cable.
	Is lamp power cable connected?	Connect lamp power cable.
	Is lamp power cable defective?	Replace lamp power cable.
	Is ballast ON/OFF switch turned on?	Place switch in the ON position.
	Is lamp loose?	Screw lamp securely into socket.
	Is lamp lit?	Replace lamp.
	Is model of lamp compatible?	Use genuine MQ lamp.
	Is output voltage at ballast correct?	No-load voltage is between 380~456 VAC. If voltage is low check 22 μ F capacitor.
	Are any other electric appliances (other than light tower) plugged into power source?	Unplug all other appliances.
Is lamp not cool enough to light again? (Interval of 20 to 30 minutes is required before turning on lamp again)	Wait for lamp to cool down	
Lamp only lights for a short time.	Is ambient temperature too high (more than 104 °F (40 °C))?	Move lamp where there is proper ventilation.
Balloon does not inflate.	Is fan motor (blower) not working properly?	Check or repair fan motor (blower).
	Is balloon envelope defective?	Repair or replace balloon envelope.

WIRING DIAGRAM

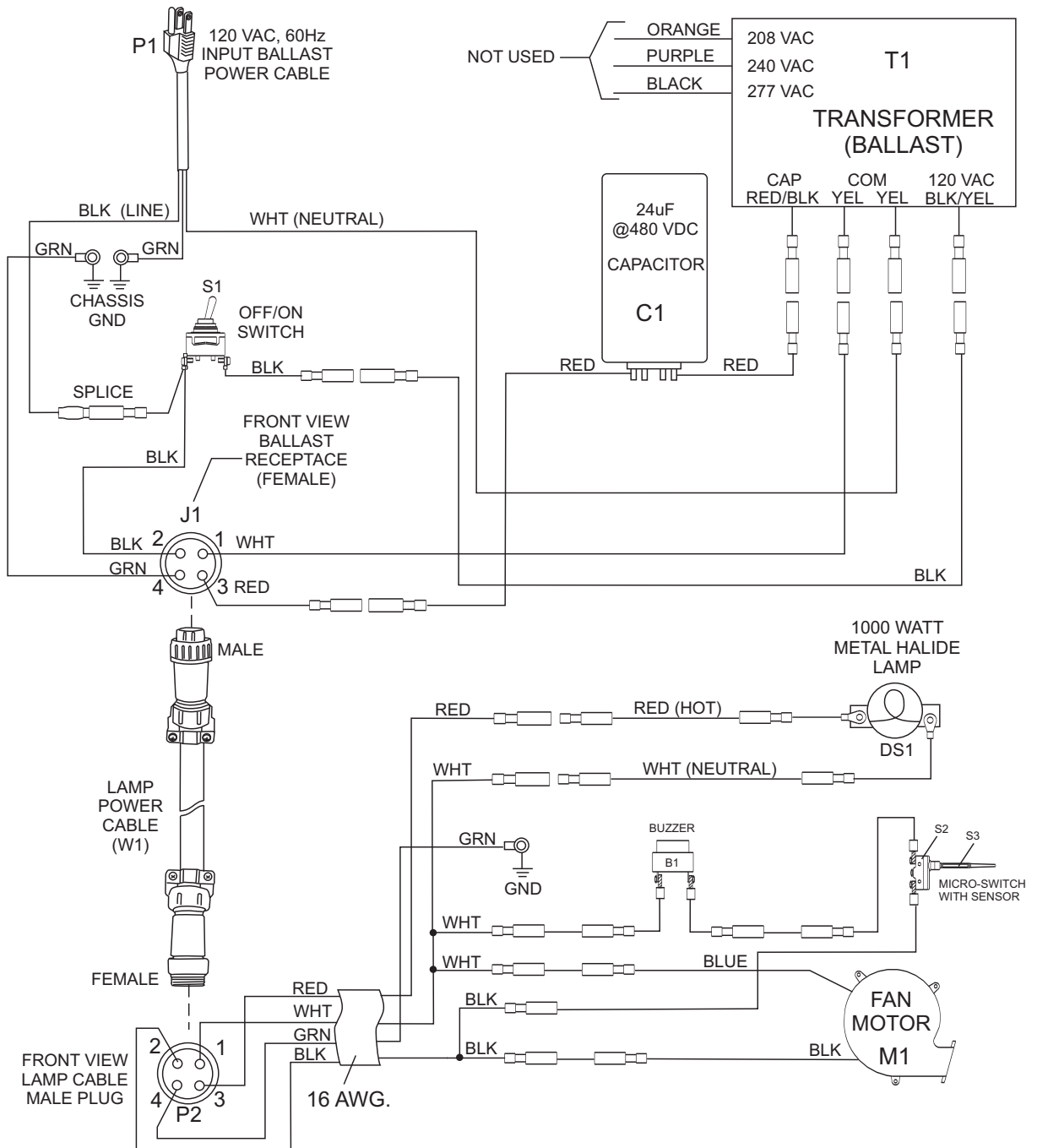

TABLE 6. REFERENCE DESIGNATIONS					
REF. DESC.	DESCRIPTION	PART NUMBER	REF. DESC.	DESCRIPTION	PART NUMBER
P1	Input Power Cable Assy.(Ballast)	A300066700	M1	Fan Motor Assy.	A300033500
J1	Ballast Output Receptacle	A400079400	B1	Buzzer Alarm Balloon	E000030100
P2	Lamp Fan Cable Assy. (Input)	A300105500	S1	ON/OFF Switch	A400037502
DS1	1000 Watt Metal Halide Lamp	E000009800	S2	Micro-Switch	1400150210
C1	24 uf Capacitor @ 480 VDC	19598	S3	Micro-Switch Cap	1400150410
T1	Ballast (Transformer)	A300033800	W1	Lamp Power Cable	A300083600

Figure 31. Electrical Wiring Diagram

VOLTAGE MEASUREMENTS

DANGER

Be careful when performing voltage measurements. The possibility exists of electrical shock if fingers make contact with connector pins, thus causing ***bodily harm or even death.***

NEVER allow multimeter test leads to make contact with each other. The possibility exists of ***electrical short causing severe damage to the equipment, bodily harm, electrocution, and even death!***

VOLTAGE MEASUREMENT (BALLAST NO-LOAD)

1. Remove lamp from pipe frame as referenced in maintenance section of this manual.
2. Place lamp in a safe place where it will not get damaged or broken.
3. Apply 120 VAC power to the ballast. Place ballast ON/OFF switch in the ON position.
4. Using a multimeter (Figure 32) measure the output voltage at the ballast receptacle. Pins 1-3 (lamp) should read between 380~465 VAC. Pins 1-2 (fan motor) should read 120 VAC.
5. Place the ballast ON/OFF switch in the OFF position.

VOLTAGE MEASUREMENT (LAMP CABLE NO-LOAD)

1. Connect the male end of the lamp power cable to the ballast female receptacle.
2. Place ballast ON/OFF switch in the ON position.
3. Using a multimeter measure the output voltage at the female end of the of the lamp power cable. Pins 1-3 (lamp) should read between 380~465 VAC. Pins 1-2 (fan motor) should read 120 VAC.
4. If voltage is not present, replace lamp power cable. Make sure connection at ballast end of cable is tight and secure (locked).
5. Place the ballast ON/OFF switch in the OFF position

VOLTAGE MEASUREMENT (LAMP SOCKET NO-LOAD)

1. Connect the female end of the lamp power cable to the male power connector that is attached to the lamp assembly.
2. Place ballast ON/OFF switch in the ON position.
3. Using a multimeter, place one test lead on the lamp socket tab, place the other lead on the threaded portion of the socket.
4. A voltage between 380~465 VAC should be present between lamp socket tab and threaded portion of the lamp socket. If the voltage is not present, check wiring inside pipe frame and lamp socket.
5. Place the ballast ON/OFF switch in the OFF position.

VOLTAGE MEASUREMENT (FAN MOTOR)

1. Make sure the lamp power cable is securely connected between the ballast receptacle and the lamp assembly power connector.
2. Place the ballast ON/OFF switch in the OFF position. It is not required for the fan motor test measurement.
3. Apply 120 VAC power to the ballast and listen for the whirring sound of the fan motor. This sound will indicate that the fan motor is running.
4. If the fan motor is not running, use a multimeter and place one test lead on the black wire and the other lead on the blue wire as shown in Figure 32.

NOTICE

You may have to use test leads that can prick the wire insulation. The voltage measured should be 120 VAC. If 120 VAC is not present check wiring inside pipe frame.

5. Additional voltage check can me made at the fan motor capacitor. Place the multimeter test leads across the tabs on the capacitor. A voltage of approximately 208 VAC should be measured. If 208 VAC is not present check or replace capacitor.

VOLTAGE MEASUREMENTS

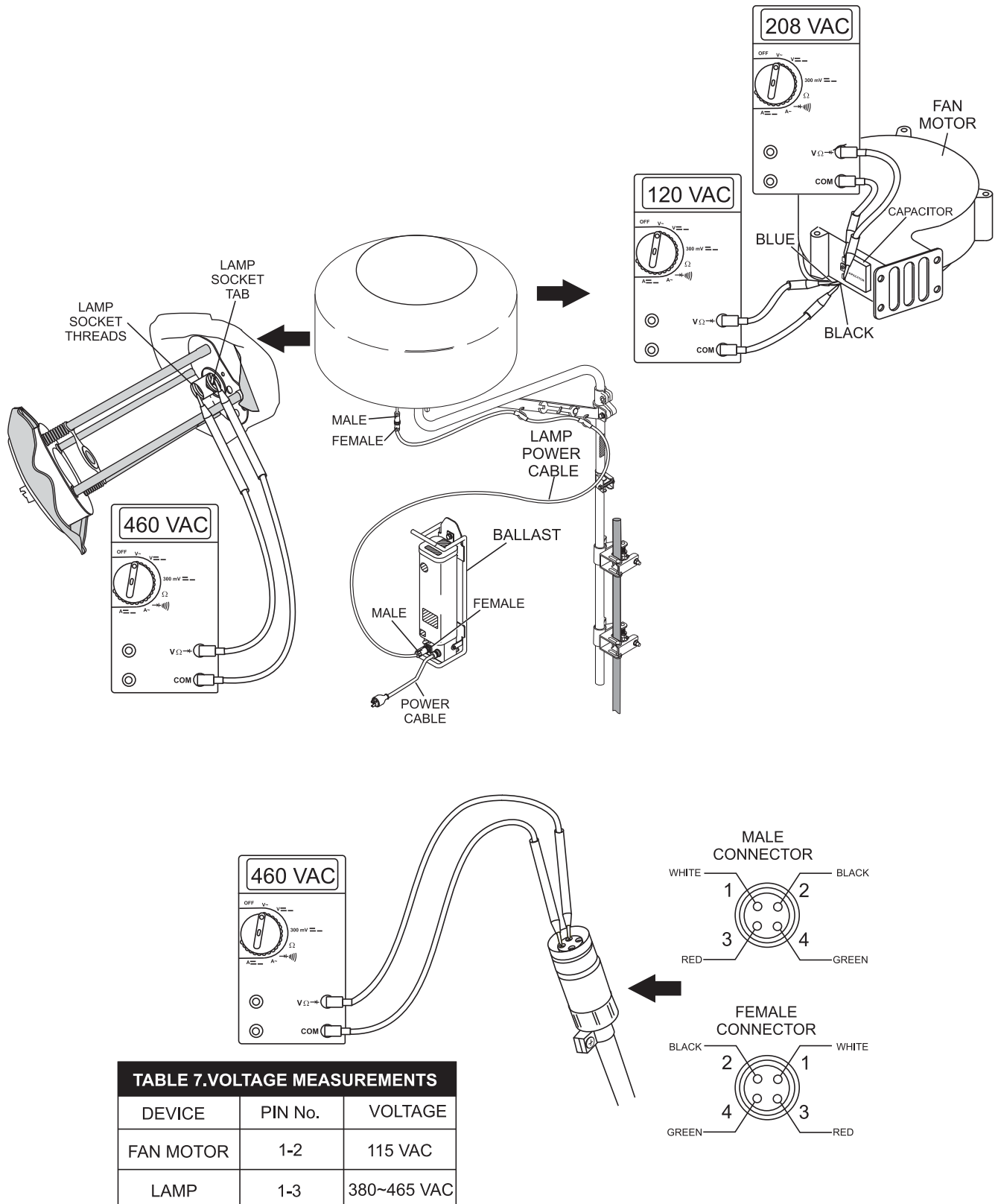

Figure 32. Voltage Measurements

EXPLANATION OF CODE IN REMARKS COLUMN

The following section explains the different symbols and remarks used in the Parts section of this manual. Use the help numbers found on the back page of the manual if there are any questions.

The contents and part numbers listed in the parts section are subject to change **without notice**. Multiquip does not guarantee the availability of the parts listed.

Sample Parts List:

NO.	PART NO.	PART NAME	QTY.	REMARKS
1	12345	BOLT	1	INCLUDES ITEMS W/*
2*		WASHER, 1/4 IN.		NOT SOLD SEPARATELY
2*	12347	WASHER, 3/8 IN. ... 1		MQ-45T ONLY
3	12348	HOSE	A/R	MAKE LOCALLY
4	12349	BEARING	1	S/N 2345B AND ABOVE

NO. Column

Unique Symbols - All items with same unique symbol (*, #, +, %, or >) in the number column belong to the same assembly or kit, which is indicated by a note in the "Remarks" column.

Duplicate Item Numbers - Duplicate numbers indicate multiple part numbers are in effect for the same general item, such as different size saw blade guards in use or a part that has been updated on newer versions of the same machine.



When ordering a part that has more than one item number listed, check the remarks column for help in determining the proper part to order.

PART NO. Column

Numbers Used - Part numbers can be indicated by a number, a blank entry, or TBD.

TBD (To Be Determined) is generally used to show a part that has not been assigned a formal part number at time of publication.

A blank entry generally indicates that the item is not sold separately or is not sold by Multiquip. Other entries will be clarified in the "Remarks" Column.

QTY. Column

Numbers Used - Item quantity can be indicated by a number, a blank entry, or A/R.

A/R (As Required) is generally used for hoses or other parts that are sold in bulk and cut to length.

A blank entry generally indicates that the item is not sold separately. Other entries will be clarified in the "Remarks" Column.

REMARKS Column

Some of the most common notes found in the "Remarks" Column are listed below. Other additional notes needed to describe the item can also be shown.

Assembly/Kit - All items on the parts list with the same unique symbol will be included when this item is purchased.

Indicated by:

"INCLUDES ITEMS W/(unique symbol)"

Serial Number Break - Used to list an effective serial number range where a particular part is used.

Indicated by:

"S/N XXXXX AND BELOW"

"S/N XXXX AND ABOVE"

"S/N XXXX TO S/N XXX"

Specific Model Number Use - Indicates that the part is used only with the specific model number or model number variant listed. It can also be used to show a part is NOT used on a specific model or model number variant.

Indicated by:

"XXXXX ONLY"

"NOT USED ON XXXX"

"Make/Obtain Locally" - Indicates that the part can be purchased at any hardware shop or made out of available items. Examples include battery cables, shims, and certain washers and nuts.

"Not Sold Separately" - Indicates that an item cannot be purchased as a separate item and is either part of an assembly/kit that can be purchased, or is not available for sale through Multiquip.

SUGGESTED SPARE PARTS

GB114BP/BS GLOBUG LIGHTING SYSTEM

1 to 3 units

<u>QTY.</u>	<u>P/N</u>	<u>DESCRIPTION</u>
2.....	LB41827	LAMP
2.....	A300033800	BALLAST
2.....	A300038400	CAPACITOR 22 μ F @ 480 VDC
2.....	1654000230.....	BALLOON PATCH KIT

NAMEPLATE AND DECALS

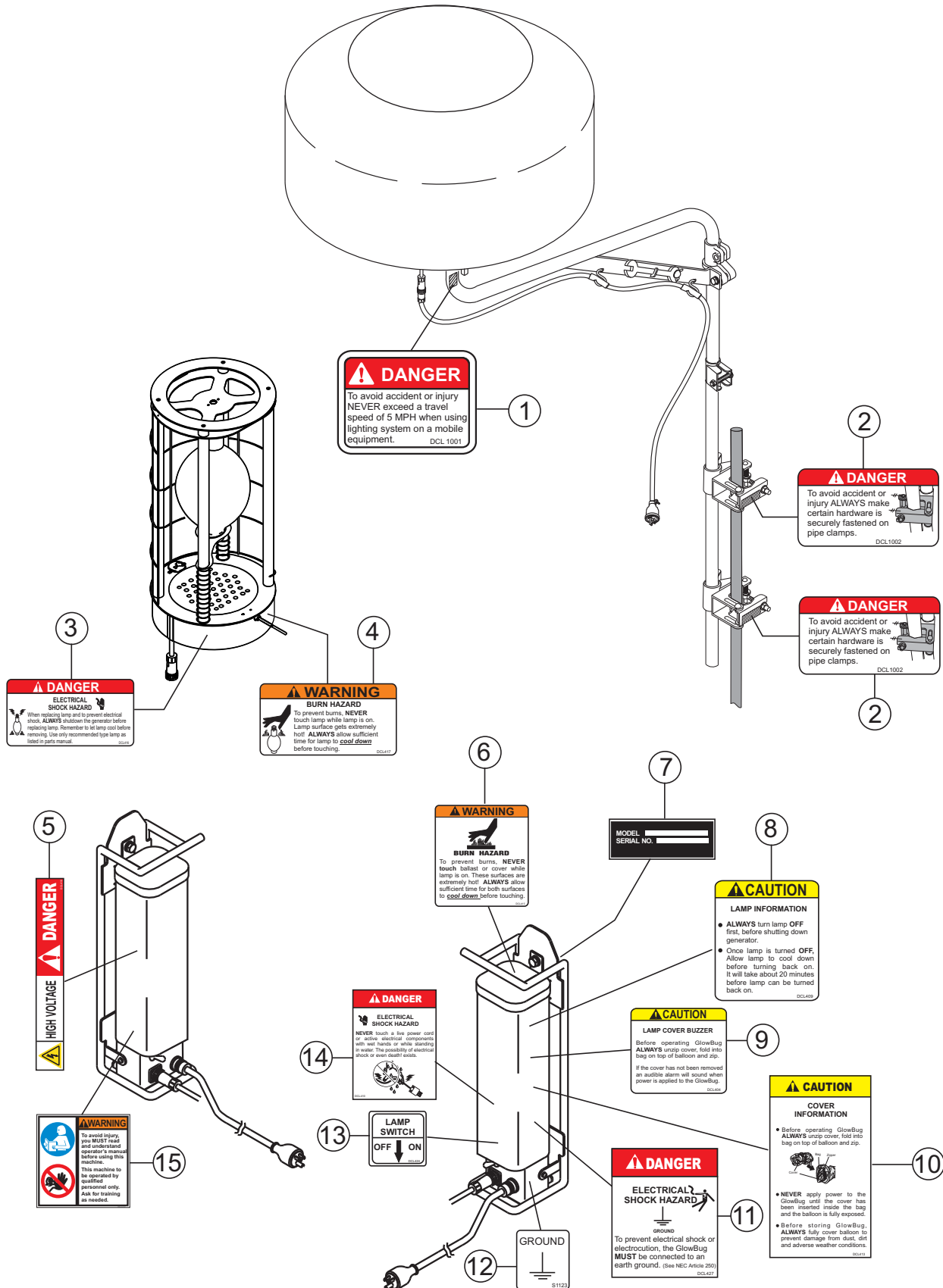

NAMEPLATE AND DECALS

<u>NO.</u>	<u>PART NO.</u>	<u>PART NAME</u>	<u>QTY.</u>	<u>REMARKS</u>
1	DCL1001	DECAL; DANGER, TRAVEL SPEED.....	1	REPLACES P/N A400084000
2	DCL1002	DECAL; DANGER, PIPE CLAMP	1	
3	DCL416	DECAL; DANGER, ELECTRICAL SHOCK HAZ.	1	
4	DCL417	DECAL; WARNING, BURN HAZARD (LAMP)	1	
5	DCL418	DECAL; DANGER, HIGH VOLTAGE	1	
6	DCL415	DECAL; BURN HAZARD (BALLAST)	1	
7		NAMEPLATE.....	1	CONTACT MQ PARTS DEPT.
8	DCL409	DECAL; CAUTION, LAMP INFORMATION	1	
9	DCL404	DECAL; CAUTION LAMP COVER BUZZER	1	
10	DCL413	DECAL; CAUTION COVER INFORMATION	1	
11	DCL427	DECAL; DANGER, ELECTRICALSHOCK HAZARD	1	
12	0800628504	DECAL; GROUND	1	
13	DCL424	DECAL: LAMP SWITCH ON/OFF	1	
14	DCL410	DECAL; DANGER, ELECTRICAL SHOCK (CORDS)	1	
15	35137	DECAL; WARNING, READ MANUAL	1	

BALLAST ASSEMBLY. S/N G30001

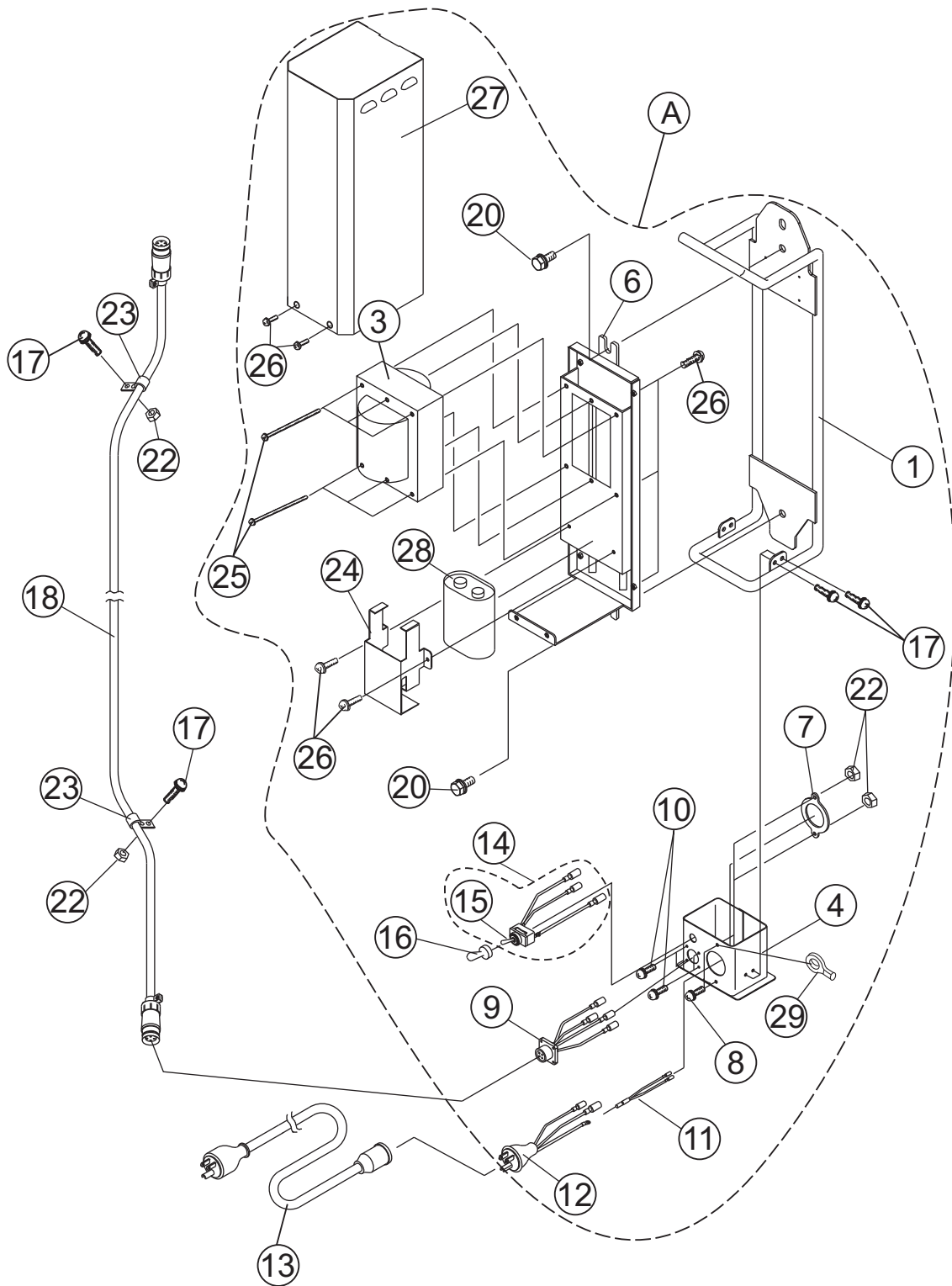

BALLAST ASSEMBLY. S/N G30001

<u>NO.</u>	<u>PART NO.</u>	<u>PART NAME</u>	<u>QTY.</u>	<u>REMARKS</u>
A	A000017700	BALLAST ASSY.....	1	INCLUDES ITEMS W/ \$
1\$	A100010202	FRAME	1	
3\$	A300033800	BALLAST (TRANSFORMER) CP	1	INCLUDES ITEM W/ %
4\$	A200016900	CASE (WIRE)	1	
6\$	A200018100	CASE (BALLAST) 1 CP	1	
7\$	A400035200	HOLDER (PLUG)	1	
8\$	0020104015	SCREW & WASHER (M4x15)	2	
9\$	A400037600	CABLE (LAMP) CP	1	
10\$	0020503012	SCREW & WASHER (M3x12)	4	
11\$	A400038200	CABLE (JOINT)	1	
12\$	A400035800	PLUG CP	1	
13	A300034700	CABLE (MAIN) CP	1	
14\$	A400037500	SWITCH ASSY.....	1	INCLUDES ITEM W/ #
15\$#	E000036400	TOGGLE SWITCH.....	1	REPLACES P/N 1406000610
16\$	1406000700	RUBBER CAP	1	
17	0023304008	SCREW & WASHER (M4x8)	4	
18	A300034800	CABLE (LAMP) CP	1	
20	0013510025	BOLT & WASHER (M10x25)	2	
22	0033104000	NUT (M4)	4	
23	A400034100	CLAMP	2	
24\$	A200018200	HOLDER	1	
25\$	0023305090	SCREW & WASHER (M5x90)	6	
26\$	0023304012	SCREW & WASHER (M4x12)	10	
27\$	A100013500	CASE (BALLAST) 2 CP	1	
28\$%	19598	CAPACITOR, 24 μ F @ 480 VDC	1	
29\$	1367020430	GROUNDING TERMINAL	1	

BALLAST ASSEMBLY. S/N G30002 & ABOVE

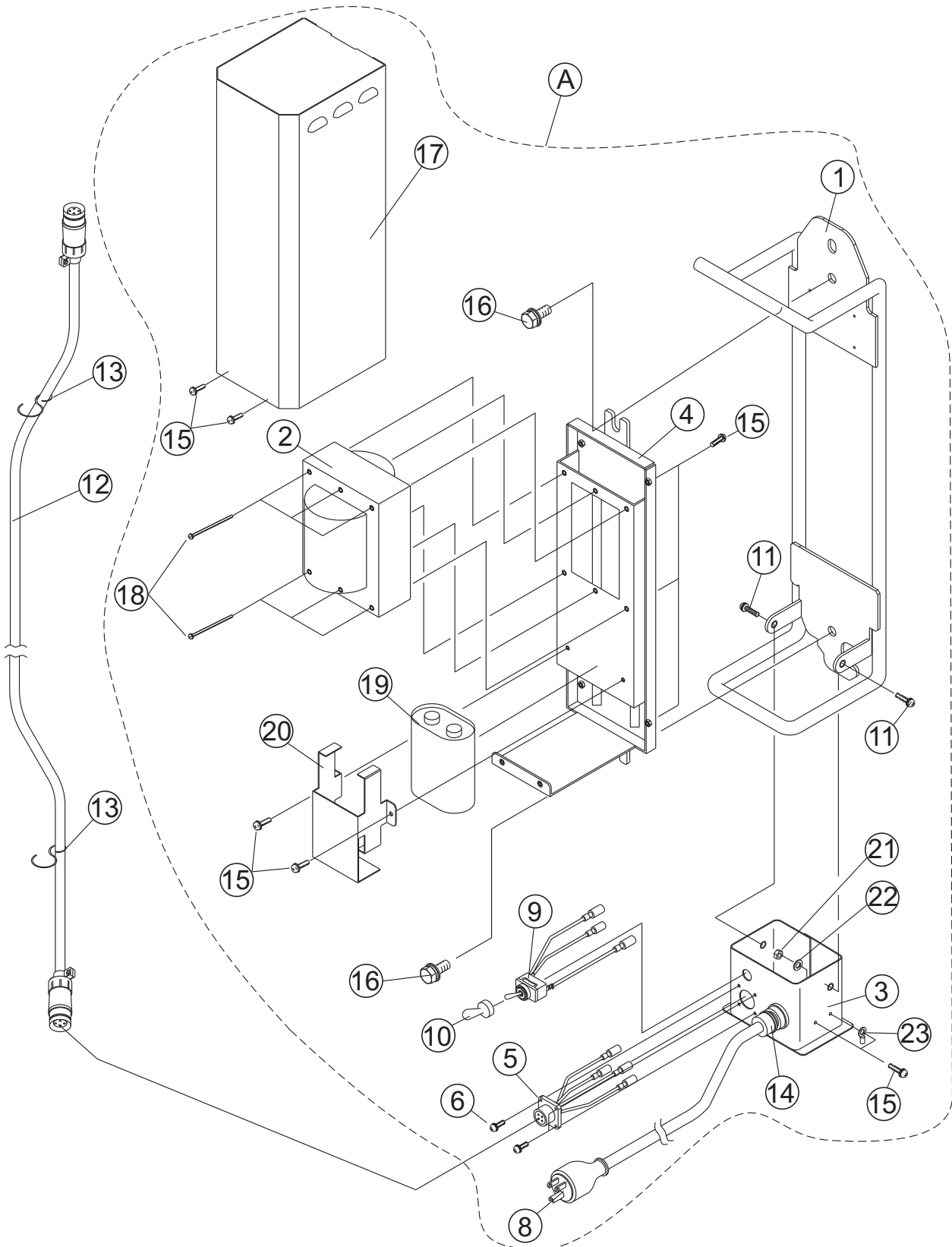

BALLAST ASSEMBLY. S/N G30002 & ABOVE

<u>NO.</u>	<u>PART NO.</u>	<u>PART NAME</u>	<u>QTY.</u>	<u>REMARKS</u>
A	A000017702	BALLAST ASSY.....	1.....	INCLUDES ITEMS W/ \$
1\$	A100015401	FRAME	1	
2\$	A300033800	BALLAST (TRANSFORMER) CP.....	1.....	INCLUDES ITEM W/ %
3\$	A200020904	CASE (WIRE)	1	
4\$	A200018100	CASE (BALLAST) 1 CP	1	
5\$	A400079400	CABLE (LAMP) CP	1	
6\$	0023303008	SCREW & WASHER (M3x8L)	4	
8\$	A300066700	CABLE (MAIN) CP	1	
9\$	A400037502	SWITCH ASSY.	1	
10\$	1406000700	RUBBER CAP	1	
11\$	0023306012	SCREW (M6x12L)	2	
12	A300083600	CABLE (LAMP) CP	1	
13	E000028200	S-HOOK	2	
14\$	E000045000	CABLE CLAMP	2	
15\$	0023304012	SCREW & WASHER (M4x12L)	12	
16\$	0013510025	BOLT & WASHER (M10x25)	2	
17\$	A100013500	CASE (BALLAST) 2 CP	1	
18\$	0023305090	SCREW & WASHER (M5x90)	6	
19\$%	A300038400	CAPACITOR, 24 μ F @ 480 VDC	1	
20\$	A200018200	HOLDER	1	
21\$	0033104000	NUT (M4)	2	
22\$	0043204000	WASHER, LOCK (M4)	2	
23\$	1367020430	TERMINAL (R)	1	

FAN BLOWER/LAMP BASE ASSEMBLY

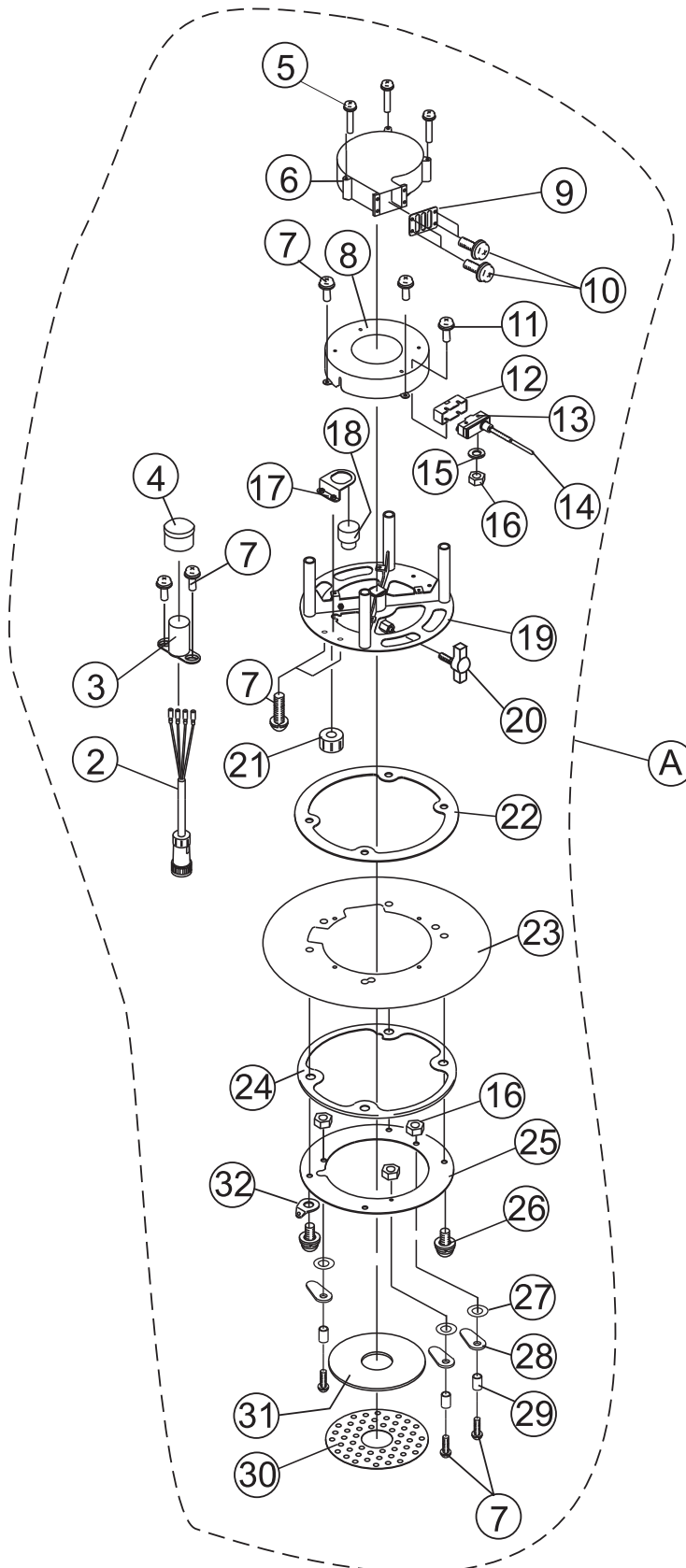

FAN BLOWER/LAMP BASE ASSEMBLY

NO.	PART NO.	PART NAME	QTY.	REMARKS
A	A000017600	BALLOON ASSY	1	S/N G30001 SEE NOTE 1
A	A000017601	BALLOON ASSY	1	S/N G30002 AND ABOVE SEE NOTE 2
2\$	A300033600	CABLE 1 (BALLOON) CP, QUICK-DISCONNECT	1	S/N G30001
2%	A300105500	CABLE 1 (BALLOON) CP, THREADED	1	S/N G30002 AND ABOVE
3#	A400038900	COVER (WIRE)	1	
4#	E000011900	COVER	1	
5#	0023305060	SCREW & WASHER (M5x60)	3	
6#	A300033500	FAN MOTOR CP	1	
7#	0024304008	SCREW (M4x8)	9	
8#	A200017702	FAN SUPPORT	1	
9#	A400037400	GUARD (FAN)	1	
10#	0023105008	SCREW (M5x8)	2	
11#	0023204030	SCREW (M4x30)	2	
12#	1400150300	MICRO SWITCH COVER	1	
13#	1400150210	MICRO SWITCH	1	
14#	1400150410	MICRO SWITCH CAP (SENSOR)	1	
15#	0043104000	WASHER (M4)	2	
16#	0033104000	NUT (M4)	5	
17#	A400038601	BRACKET (BUZZER)	1	
18#	E000030100	BUZZER	1	
19\$	A100013301	FLANGE.....	1	S/N G30001
19%	A100013302	FLANGE.....	1	S/N G30002 AND ABOVE
20#	E000065400	T-HANDLE KNOB	1	
21\$	E000010400	CABLE CLAMP	1	S/N G30001
21%	E000045000	CABLE CLAMP	1	S/N G30002 AND ABOVE
22#	2204500130	SEAL (NORMAL)	1	
23#	1800001100	SHEET (BOTTOM)	1	
24#	2204500230	PACKING	1	
25#	A300034400	PLATE (BOTTOM)	1	
26#	0014808025	BUTTON SCREW & WASHER (M8x25)	8	
27#	E000009701	WAVE WASHER (M5)	3	
28#	A400030700	STOPPER (FILTER) CP	3	
29#	E000010301	SPACER	3	
30#	A200018000	PLATE (AIR)	1	
31#	A400038300	FILTER 200 (AIR)	1	
32#	2204510110	WASHER	1	

NOTE 1: Balloon assembly A includes all items w/ # and \$ on the Fan Blower/Lamp Base Assy parts list on this page AND on the Balloon/LampGuard Assy. parts list.

NOTE 2: Balloon assembly A includes all items w/ # and % on the Fan Blower/Lamp Base Assy parts list on this page AND on the Balloon/LampGuard Assy. parts list.

BALLOON/LAMP GUARD ASSEMBLY

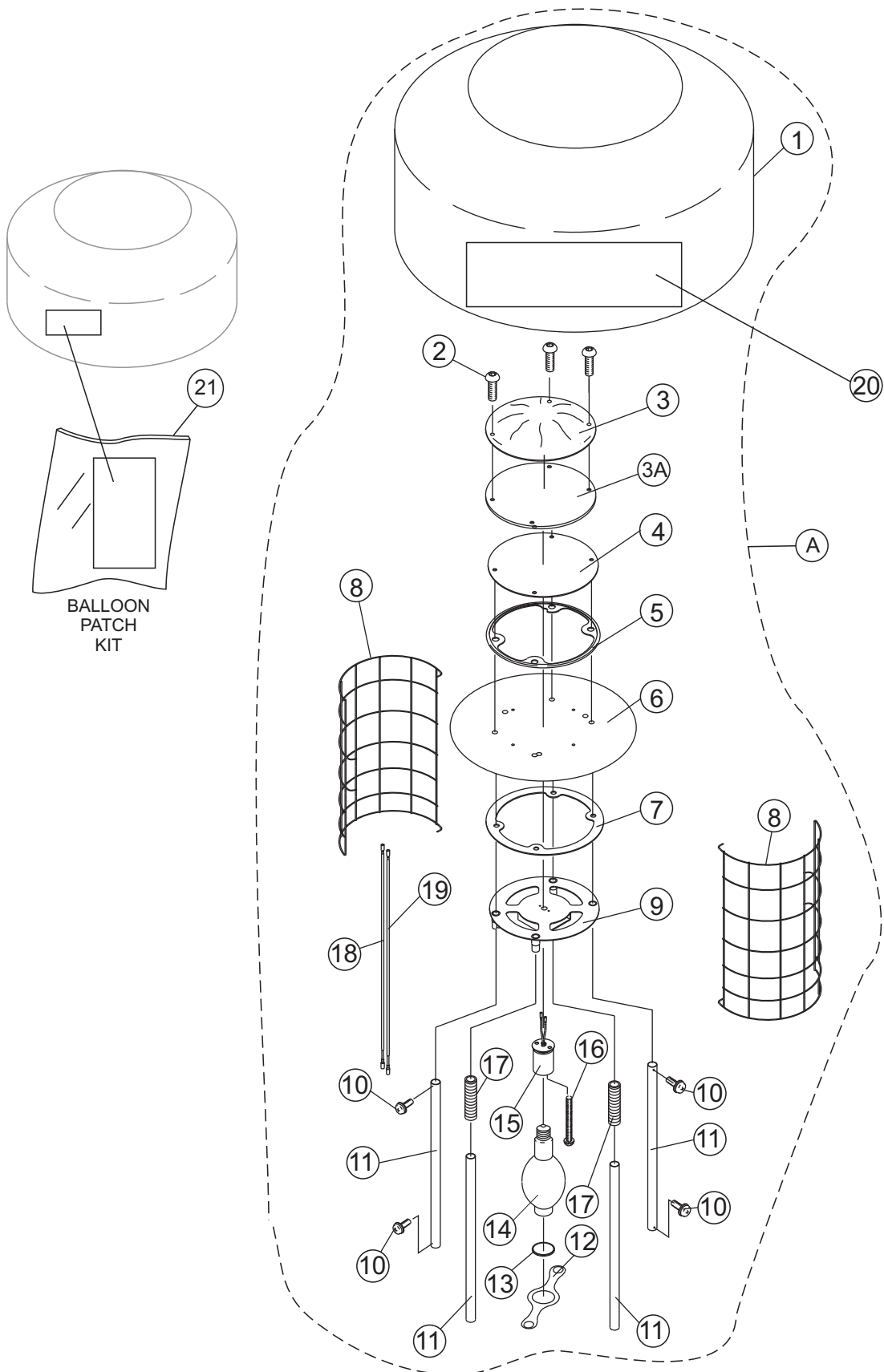

BALLOON/LAMP GUARD ASSEMBLY

<u>NO.</u>	<u>PART NO.</u>	<u>PART NAME</u>	<u>QTY.</u>	<u>REMARKS</u>
A	A000017600	BALLOON ASSY	1	S/N G30001 SEE NOTE 1
A	A000017601	BALLOON ASSY	1	S/N G30002 AND ABOVE SEE NOTE 2
1	GBBAL120	BALLOON CLOTH CP (OVAL-SHAPED)	1	OPTIONAL
1#	GBBAL115D	BALLOON CLOTH CP (DRUM-SHAPED)	1	
2#	0011808025	BUTTON SCREW & WASHER (M8 X 25)	4	
3#	A100028505	BALLOON COVER	1	REPLACES P/N A100028503
3A#	A300060202	SEAL (TOP)	1	
4#	2204220130	PLATE (CAP)	1	
5#	2204500230	PACKING	1	
6#	1800001000	SHEET (TOP)	1	
7#	2204500130	SEAL NORMAL (TOP)	1	
8#	A100010800	LAMP GUARD	2	
9#	A300026901	PLATE (LAMP)	1	
10#	0024304008	SCREW (M4x8)	4	
11#	2204400130	FRAME PIPE	4	
12#	A300032700	PLATE (LAMP HOLDER)	1	
13#	2204231730	RUBBER (LAMP)	1	
14#	E00009800	LAMP	1	REPLACES P/N LB41827
15#	E000009601	SOCKET ASSY	1	
16#	0025304025	SCREW & WASHER (M4x25)	2	
17#	2204231530	SPRING (LAMP)	2	
18#	A400038400	CABLE (LAMP) 1 R CP	1	
19\$	A400038500	CABLE (LAMP) 1 G CP	1	S/N G30001
19%	A400038501	CABLE (LAMP) 1 W CP	1	S/N G30002 AND ABOVE
20	GBBALD1	BLANK MESSAGE STRIP (OPTIONAL)	1	CONTACT MQ UNIT SALES
21	1654000230	BALLOON PATCH KIT (OPTIONAL)	1	

NOTE 1: Balloon assembly A includes all items w/ # and \$ on the Balloon/LampGuard Assy parts list on this page AND on the Fan Blower/Lamp Base Assy. parts list.

NOTE 2: Balloon assembly A includes all items w/ # and % on the Balloon/LampGuard Assy parts list on this page AND on the Fan Blower/Lamp Base Assy. parts list.

OFFSET POLE ASSEMBLY

<u>NO.</u>	<u>PART NO.</u>	<u>PART NAME</u>	<u>QTY.</u>	<u>REMARKS</u>
A	A000018200	OFFSET POLE ASSY.....	1	INCLUDES ITEMS W/ \$
1\$	A200019103	OFFSET POLE	1	
2\$	A200018303	ADAPTER (OFFSET PIPE)	1	
3\$	0013512045	BOLT AND WASHER (M12X45)	1	
4\$	0014210025	WING BOLT (M10X25)	1	
5\$	0013510025	BOLT AND WASHER (M10X25)	1	
6\$	0043110026	WASHER (M10)	1	
7\$	E000028100	17/19 MM WRENCH	1	
8\$	A300040904	POLE 2	1	
9\$	A200021902	POLE 1	1	
10\$	0013112055	BOLT (M12X55)	1	
11\$	0043212000	SPRING WASHER (M12)	2	
12\$#	0043112000	WASHER (M12)	4	
13\$#	0030810000	PUSH NUT (M10)	4	
14\$#	0043110000	WASHER (M10)	6	
15\$#	E000028300	SPACER	2	
16\$#	E000028401	BOLT (M10X80)	2	
17\$#	A400067600	SPRING	2	
18\$#	A400061500	RIVET	2	
19\$#	A300053901	CLAMP 1	2	
20\$#	A200025203	CLAMP 2	2	
21\$#	A300043601	BAND (POLE) 3T	2	
22\$#	E000042101	NUT (M12)	2	
23\$#	E000042001	NUT (M10)	2	
24\$#	0054010060	RIVET (10-60)	2	
25\$	A400082101	SHAFT (STOPPER) CP	1	
26\$	0033206000	SELF LOCK NUT (M6)	1	
27\$	0040825000	C-CLIP	1	
28\$	0013112065	BOLT (M12X65)	1	
29\$	A000025300	POLE CLAMP ASSEMBLY	2	INCLUDES ITEMS W/ #

TERMS AND CONDITIONS OF SALE — PARTS

PAYMENT TERMS

Terms of payment for parts are net 30 days.

FREIGHT POLICY

All parts orders will be shipped collect or prepaid with the charges added to the invoice. All shipments are F.O.B. point of origin. Multiquip's responsibility ceases when a signed manifest has been obtained from the carrier, and any claim for shortage or damage must be settled between the consignee and the carrier.

MINIMUM ORDER

The minimum charge for orders from Multiquip is \$15.00 net. Customers will be asked for instructions regarding handling of orders not meeting this requirement.

RETURNED GOODS POLICY

Return shipments will be accepted and credit will be allowed, subject to the following provisions:

1. A Returned Material Authorization must be approved by Multiquip prior to shipment.
2. To obtain a Return Material Authorization, a list must be provided to Multiquip Parts Sales that defines item numbers, quantities, and descriptions of the items to be returned.
 - a. The parts numbers and descriptions must match the current parts price list.
 - b. The list must be typed or computer generated.
 - c. The list must state the reason(s) for the return.
 - d. The list must reference the sales order(s) or invoice(s) under which the items were originally purchased.
 - e. The list must include the name and phone number of the person requesting the RMA.
3. A copy of the Return Material Authorization must accompany the return shipment.
4. Freight is at the sender's expense. All parts must be returned freight prepaid to Multiquip's designated receiving point.

5. Parts must be in new and resalable condition, in the original Multiquip package (if any), and with Multiquip part numbers clearly marked.
6. The following items are not returnable:
 - a. Obsolete parts. (If an item is in the price book and shows as being replaced by another item, it is obsolete.)
 - b. Any parts with a limited shelf life (such as gaskets, seals, "O" rings, and other rubber parts) that were purchased more than six months prior to the return date.
 - c. Any line item with an extended dealer net price of less than \$5.00.
 - d. Special order items.
 - e. Electrical components.
 - f. Paint, chemicals, and lubricants.
 - g. Decals and paper products.
 - h. Items purchased in kits.
7. The sender will be notified of any material received that is not acceptable.
8. Such material will be held for five working days from notification, pending instructions. If a reply is not received within five days, the material will be returned to the sender at his expense.
9. Credit on returned parts will be issued at dealer net price at time of the original purchase, less a 15% restocking charge.
10. In cases where an item is accepted, for which the original purchase document can not be determined, the price will be based on the list price that was effective twelve months prior to the RMA date.
11. Credit issued will be applied to future purchases only.

PRICING AND REBATES

Prices are subject to change without prior notice. Price changes are effective on a specific date and all orders received on or after that date will be billed at the revised price. Rebates for price declines and added charges for price increases will not be made for stock on hand at the time of any price change.

Multiquip reserves the right to quote and sell direct to Government agencies, and to Original Equipment Manufacturer accounts who use our products as integral parts of their own products.

SPECIAL EXPEDITING SERVICE

A \$35.00 surcharge will be added to the invoice for special handling including bus shipments, insured parcel post or in cases where Multiquip must personally deliver the parts to the carrier.

LIMITATIONS OF SELLER'S LIABILITY

Multiquip shall not be liable hereunder for damages in excess of the purchase price of the item with respect to which damages are claimed, and in no event shall Multiquip be liable for loss of profit or good will or for any other special, consequential or incidental damages.

LIMITATION OF WARRANTIES

No warranties, express or implied, are made in connection with the sale of parts or trade accessories nor as to any engine not manufactured by Multiquip. Such warranties made in connection with the sale of new, complete units are made exclusively by a statement of warranty packaged with such units, and Multiquip neither assumes nor authorizes any person to assume for it any other obligation or liability whatever in connection with the sale of its products. Apart from such written statement of warranty, there are no warranties, express, implied or statutory, which extend beyond the description of the products on the face hereof.

Effective: February 22, 2006

OPERATION AND PARTS MANUAL

HERE'S HOW TO GET HELP

PLEASE HAVE THE MODEL AND SERIAL
NUMBER ON-HAND WHEN CALLING

UNITED STATES

Multiquip Corporate Office

18910 Wilmington Ave. Tel. (800) 421-1244
Carson, CA 90746 Fax (800) 537-3927
Contact: mq@multiquip.com

Mayco Parts

800-306-2926 Fax: 800-672-7877
310-537-3700 Fax: 310-637-3284

Service Department

800-421-1244 Fax: 310-537-4259
310-537-3700

MQ Parts Department

800-427-1244 Fax: 800-672-7877
310-537-3700 Fax: 310-637-3284

Warranty Department

800-421-1244, Ext. 279 Fax: 310-537-1173
310-537-3700, Ext. 279

Technical Assistance

800-478-1244 Fax: 310-631-5032

MEXICO

MQ Cipsa

Carr. Fed. Mexico-Puebla KM 126.5 Tel: (52) 222-225-9900
Momoxpan, Cholula, Puebla 72760 Mexico Fax: (52) 222-285-0420
Contact: pmastretta@cipsa.com.mx

UNITED KINGDOM

Multiquip (UK) Limited Head Office

Hanover Mill, Fitzroy Street, Tel: 0161 339 2223
Ashton-under-Lyne, Fax: 0161 339 3226
Lancashire OL7 0TL
Contact: sales@multiquip.co.uk

CANADA

Multiquip

4110 Industriel Boul. Tel: (450) 625-2244
Laval, Quebec, Canada H7L 6V3 Fax: (450) 625-8664
Contact: jmartin@multiquip.com

© COPYRIGHT 2008, MULTIQUIP INC.

Multiquip Inc, the MQ logo are registered trademarks of Multiquip Inc. and may not be used, reproduced, or altered without written permission. All other trademarks are the property of their respective owners and used with permission.

This manual MUST accompany the equipment at all times. This manual is considered a permanent part of the equipment and should remain with the unit if resold.

The information and specifications included in this publication were in effect at the time of approval for printing. Illustrations, descriptions, references and technical data contained in this manual are for guidance only and may not be considered as binding. Multiquip Inc. reserves the right to discontinue or change specifications, design or the information published in this publication at any time without notice and without incurring any obligations.

Your Local Dealer is:

