

OPERATION AND PARTS MANUAL



WHISPERWATT™ SERIES MODEL DCA800SSK2 60HZ GENERATOR (STD.) (KOMATSU SAA6D170E-3 DIESEL ENGINE)

PARTS LIST NO. C5871301004

Revision # (09/03/09)

To find the latest revision of this
publication, visit our website at:
www.mqpower.com



THIS MANUAL MUST ACCOMPANY THE EQUIPMENT AT ALL TIMES.



CALIFORNIA — Proposition 65 Warning

Diesel engine exhaust and some of its constituents are known to the State of California to cause cancer, birth defects and other reproductive harm.

REPORTING SAFETY DEFECTS

If you believe that your vehicle has a defect that could cause a crash or could cause injury or death, you should immediately inform the National Highway Traffic Safety Administration (NHTSA) in addition to notifying Multiquip at 18004211244.

If NHTSA receives similar complaints, it may open an investigation, and if it finds that a safety defect exists in a group of vehicles, it may order a recall and remedy campaign. However, NHTSA cannot become involved in individual problems between you, your dealer, or Multiquip.

To contact NHTSA, you may either call the Vehicle Safety Hotline tollfree at 18883274236 (TTY: 18004249153), go to <http://www.nhtsa.dot.gov>; or write to:

Administrator
NHTSA
1200 New Jersey Avenue S.E.
Washington, DC 20590

You can also obtain information about motor vehicle safety from <http://www.safecar.gov>.

TABLE OF CONTENTS

DCA800SSK2 60 Hz Generator

Proposition 65 Warning	2
Reporting Safety Defects.....	3
Table Of Contents.....	4
Parts Ordering Procedures.....	5
Safety Information	6-11
Specifications	12
Dimensions.....	13
Installation	14-15
General Information.....	16
Major Components	17
Generator Control Panel.....	18-19
Engine Operating Panel.....	20-21
Output Terminal Panel Familiarization	22-23
Load Application	24
Generator Outputs.....	25
Generator Outputs/Gauge Reading.....	26
Output Terminal Panel Connections	27-28
Inspection/Setup.....	29-32
Generator StartUp Procedure (Manual)	34-35
Generator StartUp Procedure (Auto Mode).....	36
Generator ShutDown Procedures	37
Maintenance	38-41
Trailer Maintenance	42-45
Trailer Wiring Diagram	46
Generator Wiring Diagram.....	47
Engine Wiring Diagram.....	48
Controller Wiring Diagram	49
Controller Wiring Diagram (Main Breaker).....	49
Troubleshooting (Generator).....	50
Troubleshooting (MPEC)	51
Troubleshooting (Engine Controller)	52
Explanation Of Code In Remarks Column.....	54
Suggested Spare Parts	55

Component Drawings

Generator Assembly	56-59
Control Panel Assembly	60-61
Control Box Assembly	62-65
Engine Assembly	66-69
Radiator Assembly	70-71
Alternator Assembly	72-73
Thermostat Assembly.....	74-75
Water Pump Assembly	76-77
Starter Assembly	78-79
Engine Operating Panel Assembly	80-81
Output Terminal Assembly.....	82-85
Battery Assembly.....	86-87
Muffler Assembly	88-89
Fuel Tank Assembly	90-91
Enclosure Assembly #1	92-95
Enclosure Assembly #2	96-99
Enclosure Assembly #3.....	100-103
Rubber Seals Assembly	104-105
Nameplate and Decals Assembly	106-111

Terms and Conditions Of Sale — Parts.....	112
---	-----

PARTS ORDERING PROCEDURES

www.mqpower.com

Ordering parts has never been easier! Choose from three easy options:

Effective:
January 1st, 2006



Order via Internet (Dealers Only):

Order parts on-line using Multiquip's SmartEquip website!

- View Parts Diagrams
- Order Parts
- Print Specification Information



If you have an MQ Account, to obtain a Username and Password, E-mail us at: parts@multiquip.com.

To obtain an MQ Account, contact your District Sales Manager for more information.

Goto www.multiquip.com and click on **Order Parts** to log in and save!

Use the **internet** and qualify for a **5% Discount** on *Standard orders* for all orders which include complete part numbers.*

Note: Discounts Are Subject To Change



Order via Fax (Dealers Only):

All customers are welcome to order parts via Fax.

Domestic (US) Customers dial:
1-800-6-PARTS-7 (800-672-7877)

Fax your order in and qualify for a **2% Discount** on *Standard orders* for all orders which include complete part numbers.*

Note: Discounts Are Subject To Change



Order via Phone: Domestic (US) Dealers Call:
1-800-427-1244

Non-Dealer Customers:

Contact your local Multiquip Dealer for parts or call 800-427-1244 for help in locating a dealer near you.



International Customers should contact their local Multiquip Representatives for Parts Ordering information.

When ordering parts, please supply:

- | | |
|---|--|
| <input type="checkbox"/> Dealer Account Number | <input type="checkbox"/> Specify Preferred Method of Shipment: |
| <input type="checkbox"/> Dealer Name and Address | <input checked="" type="checkbox"/> UPS/Fed Ex <input checked="" type="checkbox"/> DHL |
| <input type="checkbox"/> Shipping Address (if different than billing address) | <input type="checkbox"/> Priority One <input checked="" type="checkbox"/> Truck |
| <input type="checkbox"/> Return Fax Number | <input type="checkbox"/> Ground |
| <input type="checkbox"/> Applicable Model Number | <input type="checkbox"/> Next Day |
| <input type="checkbox"/> Quantity, Part Number and Description of Each Part | <input type="checkbox"/> Second/Third Day |

NOTICE

All orders are treated as *Standard Orders* and will ship the same day if received prior to 3PM PST.

WE ACCEPT ALL MAJOR CREDIT CARDS!



SAFETY INFORMATION

Do not operate or service the equipment before reading the entire manual. Safety precautions should be followed at all times when operating this equipment. Failure to read and understand the safety messages and operating instructions could result in injury to yourself and others.

SAFETY MESSAGES

The four safety messages shown below will inform you about potential hazards that could injure you or others. The safety messages specifically address the level of exposure to the operator and are preceded by one of four words: **DANGER**, **WARNING**, **CAUTION** or **NOTICE**.

SAFETY SYMBOLS

 **DANGER**

Indicates a hazardous situation which, if not avoided, **WILL** result in **DEATH** or **SERIOUS INJURY**.

 **WARNING**

Indicates a hazardous situation which, if not avoided, **COULD** result in **DEATH** or **SERIOUS INJURY**.







 **CAUTION**

Indicates a hazardous situation which, if not avoided, **COULD** result in **MINOR** or **MODERATE INJURY**.

NOTICE

Addresses practices not related to personal injury.

Potential hazards associated with the operation of this equipment will be referenced with hazard symbols which may appear throughout this manual in conjunction with safety messages.

Symbol	Safety Hazard
	Lethal exhaust gas hazards
	Explosive fuel hazards
	Burn hazards
	Overspeed hazards
	Rotating parts hazards
	Pressurized fluid hazards
	Electric shock hazards

SAFETY INFORMATION

GENERAL SAFETY

CAUTION

- **NEVER** operate this equipment without proper protective clothing, shatterproof glasses, respiratory protection, hearing protection, steel-toed boots and other protective devices required by the job or city and state regulations.



- **NEVER** operate this equipment when not feeling well due to fatigue, illness or when under medication.
- **NEVER** operate this equipment under the influence of drugs or alcohol.



- **ALWAYS** check the equipment for loosened threads or bolts before starting.
- **DO NOT** use the equipment for any purpose other than its intended purposes or applications.

NOTICE

- This equipment should only be operated by trained and qualified personnel 18 years of age and older.
- Whenever necessary, replace nameplate, operation and safety decals when they become difficult read.
- Manufacturer does not assume responsibility for any accident due to equipment modifications. Unauthorized equipment modification will void all warranties.

- **NEVER** use accessories or attachments that are not recommended by MQ Power for this equipment. Damage to the equipment and/or injury to user may result.

- **ALWAYS** know the location of the nearest **fire extinguisher**.



- **ALWAYS** know the location of the nearest **first aid kit**.



- **ALWAYS** know the location of the nearest phone or **keep a phone on the job site**. Also, know the phone numbers of the nearest **ambulance, doctor and fire department**. This information will be invaluable in the case of an emergency.



GENERATOR SAFETY

DANGER

- **NEVER** operate the equipment in an explosive atmosphere or near combustible materials. An explosion or fire could result causing severe **bodily harm or even death**.



WARNING

- **NEVER** disconnect any **emergency or safety devices**. These devices are intended for operator safety. Disconnection of these devices can cause severe injury, bodily harm or even death. Disconnection of any of these devices will void all warranties.

CAUTION

- **NEVER** lubricate components or attempt service on a running machine.

NOTICE

- **ALWAYS** ensure generator is on level ground before use.
- **ALWAYS** keep the machine in proper running condition.
- Fix damage to machine and replace any broken parts immediately.
- **ALWAYS** store equipment properly when it is not being used. Equipment should be stored in a clean, dry location out of the reach of children and unauthorized personnel

SAFETY INFORMATION

ENGINE SAFETY

DANGER

- The engine fuel exhaust gases contain poisonous carbon monoxide. This gas is colorless and odorless, and can cause death if inhaled.
- The engine of this equipment requires an adequate free flow of cooling air. **NEVER** operate this equipment in any enclosed or narrow area where free flow of the air is restricted. If the air flow is restricted it will cause injury to people and property and serious damage to the equipment or engine.

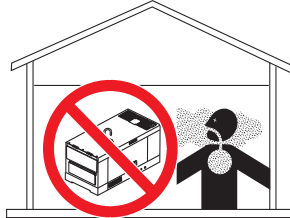

WARNING

- **DO NOT** place hands or fingers inside engine compartment when engine is running.
- **NEVER** operate the engine with heat shields or guards removed.
- Keep fingers, hands hair and clothing away from all moving parts to prevent injury.
- **DO NOT** remove the radiator cap while the engine is hot. High pressure boiling water will gush out of the radiator and severely scald any persons in the general area of the generator.
- **DO NOT** remove the coolant drain plug while the engine is hot. Hot coolant will gush out of the coolant tank and severely scald any persons in the general area of the generator.
- **DO NOT** remove the engine oil drain plug while the engine is hot. Hot oil will gush out of the oil tank and severely scald any persons in the general area of the generator.



CAUTION

- **NEVER** touch the hot exhaust manifold, muffler or cylinder. Allow these parts to cool before servicing equipment.



NOTICE

- **NEVER** run engine without an air filter or with a dirty air filter. Severe engine damage may occur. Service air filter frequently to prevent engine malfunction.
- **NEVER** tamper with the factory settings of the engine or engine governor. Damage to the engine or equipment can result if operating in speed ranges above the maximum allowable.
- Wet stacking is a common problem with diesel engines which are operated for extended periods with light or no load applied. When a diesel engine operates without sufficient load (less than 40% of the rated output), it will not operate at its optimum temperature. This will allow unburned fuel to accumulate in the exhaust system, which can foul the fuel injectors, engine valves and exhaust system, including turbochargers, and reduce the operating performance.



In order for a diesel engine to operate at peak efficiency, it must be able to provide fuel and air in the proper ratio and at a high enough engine temperature for the engine to completely burn all of the fuel.

Wet stacking does not usually cause any permanent damage and can be alleviated if additional load is applied to relieve the condition. It can reduce the system performance and increase maintenance. Applying an increasing load over a period of time until the excess fuel is burned off and the system capacity is reached usually can repair the condition. This can take several hours to burn off the accumulated unburned fuel.

- State Health Safety Codes and Public Resources Codes specify that in certain locations, spark arresters must be used on internal combustion engines that use hydrocarbon fuels. A spark arrester is a device designed to prevent accidental discharge of sparks or flames from the engine exhaust. Spark arresters are qualified and rated by the United States Forest Service for this purpose. In order to comply with local laws regarding spark arresters, consult the engine distributor or the local Health and Safety Administrator.

SAFETY INFORMATION

FUEL SAFETY

DANGER

- **DO NOT** start the engine near spilled fuel or combustible fluids. Diesel fuel is extremely flammable and its vapors can cause an explosion if ignited.
- **ALWAYS** refuel in a well-ventilated area, away from sparks and open flames.
- **ALWAYS** use extreme caution when working with **flammable** liquids.
- **DO NOT** fill the fuel tank while the engine is running or hot.
- **DO NOT** overfill tank, since spilled fuel could ignite if it comes into contact with hot engine parts or sparks from the ignition system.
- Store fuel in appropriate containers, in well-ventilated areas and away from sparks and flames.
- **NEVER** use fuel as a cleaning agent.
- **DO NOT** smoke around or near the equipment. Fire or explosion could result from fuel vapors or if fuel is spilled on a hot engine.



TOWING SAFETY

CAUTION

- Check with your local county or state safety towing regulations, in addition to meeting **Department of Transportation (DOT) Safety Towing Regulations**, before towing your generator.
- Refer to MQ Power trailer manual for additional safety information.
- In order to reduce the possibility of an accident while transporting the generator on public roads, **ALWAYS** make sure the trailer that supports the generator and the towing vehicle are mechanically sound and in good operating condition.
- **ALWAYS** shutdown engine before transporting



- Make sure the hitch and coupling of the towing vehicle are rated equal to, or greater than the trailer “gross vehicle weight rating.”
- **ALWAYS** inspect the hitch and coupling for wear. **NEVER** tow a trailer with defective hitches, couplings, chains, etc.
- Check the tire air pressure on both towing vehicle and trailer. **Trailer tires should be inflated to 50 psi cold.** Also check the tire tread wear on both vehicles.
- **ALWAYS** make sure the trailer is equipped with a **safety chain**.
- **ALWAYS** properly attach trailer’s safety chains to towing vehicle.
- **ALWAYS** make sure the vehicle and trailer directional, backup, brake and trailer lights are connected and working properly.
- DOT Requirements include the following:
 - Connect and test electric brake operation.
 - Secure portable power cables in cable tray with tie wraps.
- The maximum speed for highway towing is **55 MPH** unless posted otherwise. Recommended off-road towing is not to exceed **15 MPH** or less depending on type of terrain.
- Avoid sudden stops and starts. This can cause skidding, or jack-knifing. Smooth, gradual starts and stops will improve towing.
- Avoid sharp turns to prevent rolling.
- Trailer should be adjusted to a level position at all times when towing.
- Raise and lock trailer wheel stand in up position when towing.
- Place **chock blocks** underneath wheel to prevent **rolling** while parked.
- Place **support blocks** underneath the trailer’s bumper to prevent **tipping** while parked.
- Use the trailer’s swivel jack to adjust the trailer height to a level position while parked.

SAFETY INFORMATION

ELECTRICAL SAFETY

DANGER

- **DO NOT** touch output terminals during operation. Contact with output terminals during operation can cause **electrocution, electrical shock or burn.**



- The electrical voltage required to operate the generator can cause severe injury or even death through physical contact with live circuits. Turn generator and all circuit breakers **OFF** before performing maintenance on the generator or making contact with output terminals.

- **NEVER** insert any objects into the output receptacles during operation. This is extremely dangerous. The possibility exists of **electrical shock, electrocution or death.**



- Backfeed to a utility system can cause **electrocution** and/or property damage. **NEVER** connect the generator to a building's electrical system without a transfer switch or other approved device. All installations should be performed by a **licensed electrician** in accordance with all applicable laws and electrical codes. Failure to do so could result in electrical shock or burn, causing **serious injury or even death.**



Power Cord/Cable Safety

DANGER

- **NEVER** let power cords or cables **lay in water.**
- **NEVER stand in water** while AC power from the generator is being transferred to a load.
- **NEVER** use **damaged** or **worn** cables or cords when connecting equipment to generator. Inspect for cuts in the insulation.
- **NEVER** grab or touch a live power cord or cable with wet hands. The possibility exists of **electrical shock, electrocution or death.**

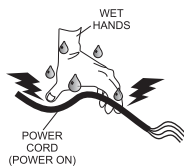

- Make sure power cables are securely connected to the generator's output receptacles. Incorrect connections may cause electrical shock and damage to the generator.

NOTICE

- **ALWAYS** make certain that proper power or extension cord has been selected for the job. See Cable Selection Chart in this manual.

Grounding Safety

DANGER

- **ALWAYS** make sure that electrical circuits are properly grounded to a suitable earth ground (ground rod) per the National Electrical Code (NEC) and local codes before operating generator. **Severe injury or death by electrocution** can result from operating an ungrounded generator.
- **NEVER** use gas piping as an electrical ground.

SAFETY INFORMATION

BATTERY SAFETY

DANGER

- **DO NOT** drop the battery. There is a possibility that the battery will explode.
- **DO NOT** expose the battery to open flames, sparks, cigarettes, etc. The battery contains combustible gases and liquids. If these gases and liquids come into contact with a flame or spark, an explosion could occur.



WARNING

- **ALWAYS** wear safety glasses when handling the battery to avoid eye irritation. The battery contains acids that can cause injury to the eyes and skin.
- Use well-insulated gloves when picking up the battery.
- **ALWAYS** keep the battery charged. If the battery is not charged, combustible gas will build up.
- **ALWAYS** recharge the battery in a well-ventilated environment to avoid the risk of a dangerous concentration of combustible gasses.
- If the battery liquid (dilute sulfuric acid) comes into contact with **clothing or skin**, rinse skin or clothing immediately with plenty of water.
- If the battery liquid (dilute sulfuric acid) comes into contact with **eyes**, rinse eyes immediately with plenty of water and contact the nearest doctor or hospital to seek medical attention.



CAUTION

- **ALWAYS** disconnect the **NEGATIVE** battery terminal before performing service on the generator.
- **ALWAYS** keep battery cables in good working condition. Repair or replace all worn cables.

ENVIRONMENTAL SAFETY

NOTICE

- Dispose of hazardous waste properly. Examples of potentially hazardous waste are used motor oil, fuel and fuel filters.
- **DO NOT** use food or plastic containers to dispose of hazardous waste.
- **DO NOT** pour waste, oil or fuel directly onto the ground, down a drain or into any water source.



SPECIFICATIONS

Table 1. Generator Specifications	
Model	DCA800SSK2 (Standard)
Type	Revolving field, self ventilated, open protected type synchronous generator
Armature Connection	Star with Neutral
Phase	3
Standby Output	880 kVA (704 kW)
Prime Output	800 kVA (640 kW)
Voltage - 1 Ø	120, 127, 139, 240, 254, 277V Adjustable
Voltage - 3 Ø	208, 220, 240, 416, 440, 480V Reconnectable
Frequency	60 Hz
Speed	1800 rpm
Power Factor	0.8
Aux. AC Power	Single Phase, 60 Hz
Aux. Voltage/Output	4.8 Kw (2.4 kW x 2)
Dry Weight	23,634 lbs. (10,720 kg.)
Wet Weight	25,308 lbs. (11,479 kg.)

Table 2. Engine Specifications					
Model	KOMATSU SAA6D170E3				
Type	4 cycle, watercooled, direct injection, turbocharged airtoair intercooled				
No. of Cylinders	6 cylinders				
Bore x Stroke	6.69in. x 6.69 in. (170 mm x 170 mm)				
Displacement	1413 cu. in. (23,150 cc)				
Rated Output	1008 HP/1800 RPM				
Starting	Electric 24 VDC				
Coolant Capacity	40.4 gal. (153 liters)				
Lube Oil Capacity	37.2 gal. (141 liters)				
Fuel Type	#2 Diesel Fuel				
Fuel Tank Capacity	129.5 gal. (490 liters)				
Fuel Consumption	<table border="1" style="width: 100%; border-collapse: collapse;"> <tr> <td style="width: 50%;">41.3 gal. (156.5 L)/hr at full load</td> <td style="width: 50%;">30.8 gal. (116.4 L)/hr at 75% load</td> </tr> <tr> <td>22.6 gal. (85.9 L)/hr at 50% load</td> <td>14.5 gal. (54.9 L)/hr at 25% load</td> </tr> </table>	41.3 gal. (156.5 L)/hr at full load	30.8 gal. (116.4 L)/hr at 75% load	22.6 gal. (85.9 L)/hr at 50% load	14.5 gal. (54.9 L)/hr at 25% load
41.3 gal. (156.5 L)/hr at full load	30.8 gal. (116.4 L)/hr at 75% load				
22.6 gal. (85.9 L)/hr at 50% load	14.5 gal. (54.9 L)/hr at 25% load				
Battery	12V 200Ah x 4 (24V System)				

DIMENSIONS

TOP VIEW

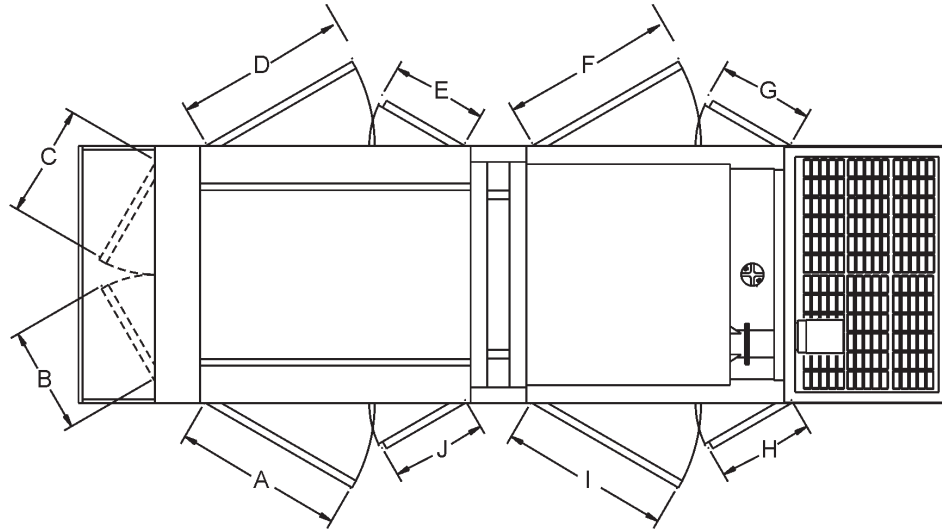

SIDE VIEW

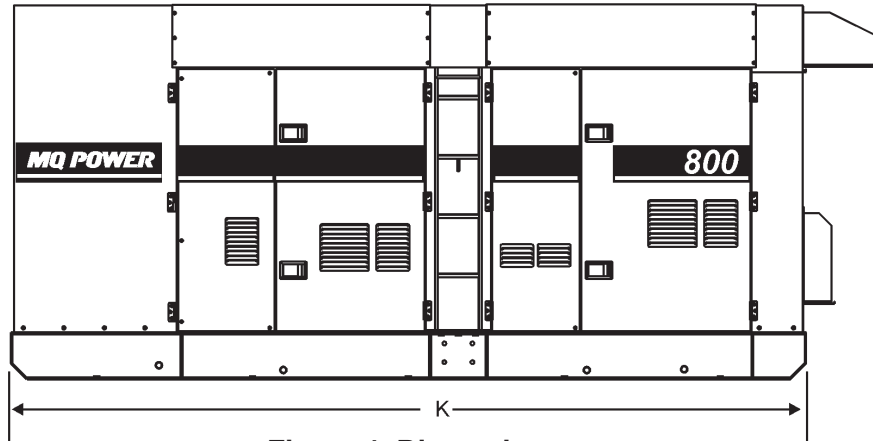

Figure 1. Dimensions

FRONT VIEW

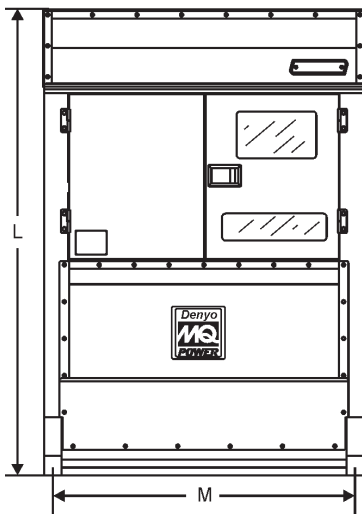

Table 3. Dimensions

Reference Letter	Dimension in. (mm)	Reference Letter	Dimension in. (mm)
A	43.31 in. (1,100 mm.)	H	32.68 in. (830 mm.)
B	36.22 in. (920 mm.)	I	39.37 in. (1000 mm.)
C	27.17 in. (690 mm.)	J	29.53 in. (750 mm.)
D	43.31 in. (1,100 mm.)	K	240.54 in. (6110 mm.)
E	29.53 in. (750 mm.)	L	98.43 in. (2500 mm.)
F	39.37 in. (1000 mm.)	M	76.77 in. (1950 mm.)
G	32.68 in. (830 mm.)		

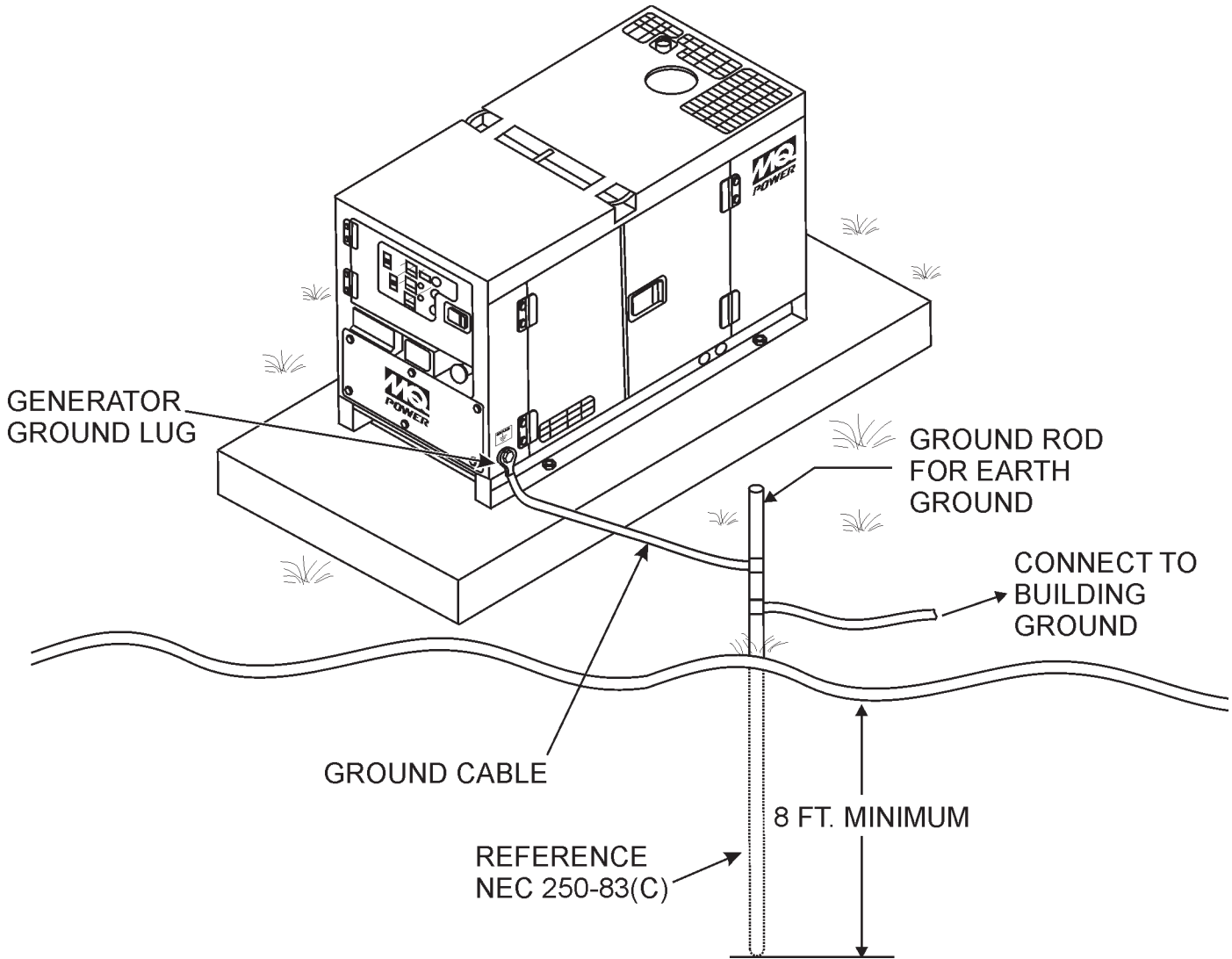

Figure 2. Typical Generator Grounding Application

OUTDOOR INSTALLATION

Install the generator in a area that is free of debris, bystanders, and overhead obstructions. Make sure the generator is on secure level ground so that it cannot slide or shift around. Also install the generator in a manner so that the exhaust will not be discharged in the direction of nearby homes.

The installation site must be relatively free from moisture and dust. All electrical equipment should be protected from excessive moisture. Failure to do will result in deterioration of the insulation and will result in short circuits and grounding.

Foreign materials such as dust, sand, lint and abrasive materials have a tendency to cause excessive wear to engine and alternator parts.

CAUTION

Pay close attention to ventilation when operating the generator inside tunnels and caves. The engine exhaust contains noxious elements. Engine exhaust must be routed to a ventilated area.

INDOOR INSTALLATION

Exhaust gases from diesel engines are extremely poisonous. Whenever an engine is installed indoors the exhaust fumes must be vented to the outside. The engine should be installed at least two feet from any outside wall. Using an exhaust pipe which is too long or too small can cause excessive back pressure which will cause the engine to heat excessively and possibly burn the valves.

MOUNTING

The generator must be mounted on a solid foundation (such as concrete) and set firmly on the foundation to isolate vibration of the generator when it is running. The generator must set at least 6 inches above the floor or grade level (in accordance to NFPA 110, Chapter 54.1). **DO NOT** remove the metal skids on the bottom of the generator. They are to resist damage to the bottom of the generator and to maintain alignment.

GENERATOR GROUNDING

To guard against electrical shock and possible damage to the equipment, it is important to provide a good **EARTH** ground (Figure 2).

Article 250 (Grounding) of the National Electrical Code (NEC) provides guide lines for proper grounding and specifies that the cable ground shall be connected to the grounding system of the building as close to the point of cable entry as practical.

NEC articles 25064(b) and 25066 set the following grounding requirements:

1. Use one of the following wire types to connect the generator to earth ground.
 - a. Copper 10 AWG (5.3 mm²) or larger.
 - b. Aluminum 8 AWG (8.4 mm²) or larger.
2. When grounding the generator (Figure 2) connect the ground cable between the lock washer and the nut on the generator and tighten the nut fully. Connect the other end of the ground cable to earth ground.
3. NEC article 25052(c) specifies that the earth ground rod should be buried a minimum of 8 ft. into the ground.

NOTICE

When connecting the generator to any buildings electrical system **ALWAYS** consult with a licensed electrician.

GENERATOR

The MQ Power Model DCA800SSK2 is a 640 kW generator (Figure 3) that is designed as a high quality portable (requires a trailer for transport) power source for telecom sites, lighting facilities, power tools, submersible pumps and other industrial and construction machinery.

ENGINE OPERATING PANEL

The “Engine Operating Panel” is provided with the following:

- Tachometer
- Emergency Stop Switch
- Water Temperature Gauge
- Oil Pressure Gauge
- Charging Ammeter Gauge
- Fuel Level Gauge
- Pilot Lamp
- PreHeat Lamp
- Engine Speed Switch
- Battery Switch
- Engine Alarm Lamps (6)

GENERATOR CONTROL PANEL

The “Generator Control Panel” is provided with the following:

- Frequency Meter (Hz)
- AC Ammeter (Amps)
- AC Voltmeter (Volts)
- Ammeter ChangeOver Switch
- Voltmeter ChangeOver Switch
- Voltage Regulator
- Panel Light/Panel Light Switch
- 3Pole, 2500 amp Main Circuit Breaker
- “Control Box” (located behind the Gen. Control Panel)
 - Automatic Voltage Regulator
 - Current Transformer
 - OverCurrent Relay
 - Voltage Rectifier
 - Starter Relay
 - Engine Controller (Computer Controlled)
 - Voltage ChangeOver Board

OUTPUT TERMINAL PANEL

The “Output Terminal Panel” is provided with the following:

- Three 240/139V output receptacles (CS6369), 50A
- Three auxiliary circuit breakers, 50A
- Eight output terminal lugs (3Ø power)
- Battery Charger (Optional)
- Water Heater (Optional)

OPEN DELTA EXCITATION SYSTEM

The DCA800SSK2 generator is equipped with the state of the art “OpenDelta” excitation system. The open delta system consist of an electrically independent winding wound among stationary windings of the AC output section.

There are four connections of the open delta A, B, C and D. During steady state loads, the power from the voltage regulator is supplied from the parallel connections of A to B, A to D, and C to D. These three phases of the voltage input to the voltage regulator are then rectified and are the excitation current for the exciter section.

When a heavy load, such as a motor starting or a short circuit occurs, the automatic voltage regulator (AVR) switches the configuration of the open delta to the series connection of B to C. This has the effect of adding the voltages of each phase to provide higher excitation to the exciter section and thus better voltage response during the application of heavy loads.

The connections of the AVR to the AC output windings are for sensing only. No power is required from these windings. The opendelta design provides virtually unlimited excitation current, offering maximum motor starting capabilities. The excitation does not have a “fixed ceiling” and responds according the demands of the required load.

ENGINE

The DCA800SSK2 is powered by a 6 cylinder, water cooled, direct injection, turbocharged airtoair KOMATSU SAA6D170E3 Diesel Engine. This engine is designed to meet every performance requirement for the generator. Reference Table 2 for engine specifications.

In keeping with MQ Power’s policy of constantly improving its products, the specifications quoted herein are subject to change without prior notice.

ELECTRIC GOVERNOR SYSTEM

The electric governor system controls the RPMs of the engine. When the engine demand increases or decreases, the governor system regulates the frequency variation to $\pm 0.25\%$.

EXTENSION CABLES

When electric power is to be provided to various tools or loads at some distance from the generator, extension cords are normally used. Cables should be sized to allow for distance in length and amperage so that the voltage drop between the generator and point of use (load) is held to a minimum. Use the cable selection chart (Table 6) as a guide for selecting proper extension cable size.

MAJOR COMPONENTS

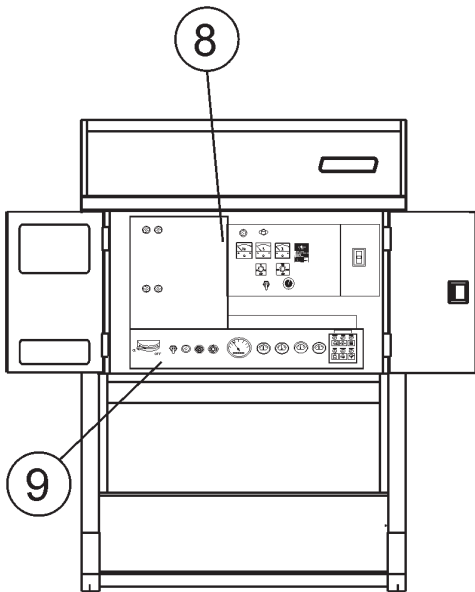
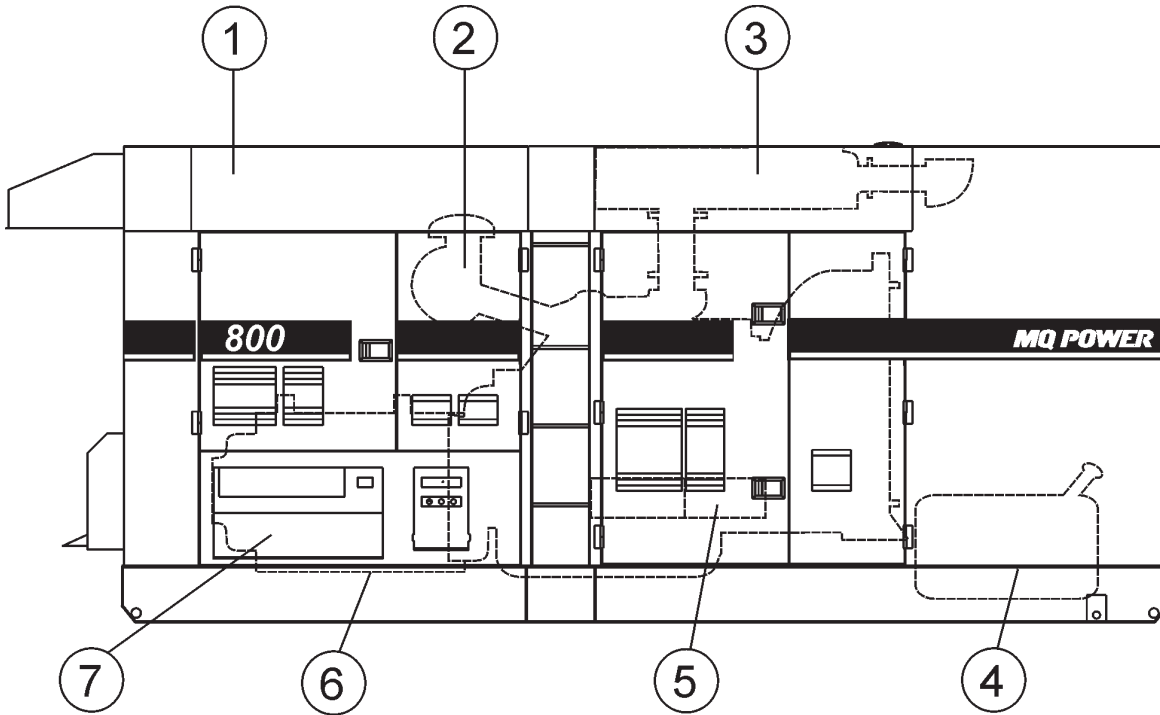

Table 4. Generator Major Components	
ITEM NO.	DESCRIPTION
1	Air Filter Assembly
2	Muffler Assembly
3	Fuel Tank Assembly
4	Engine Operating Panel Assembly
5	Battery Assembly
6	Output Terminal Panel Assembly
7	Generator Assembly
8	Generator Control Panel Assembly
9	Engine Control Panel Assembly

Figure 3. Major Components

GENERATOR CONTROL PANEL

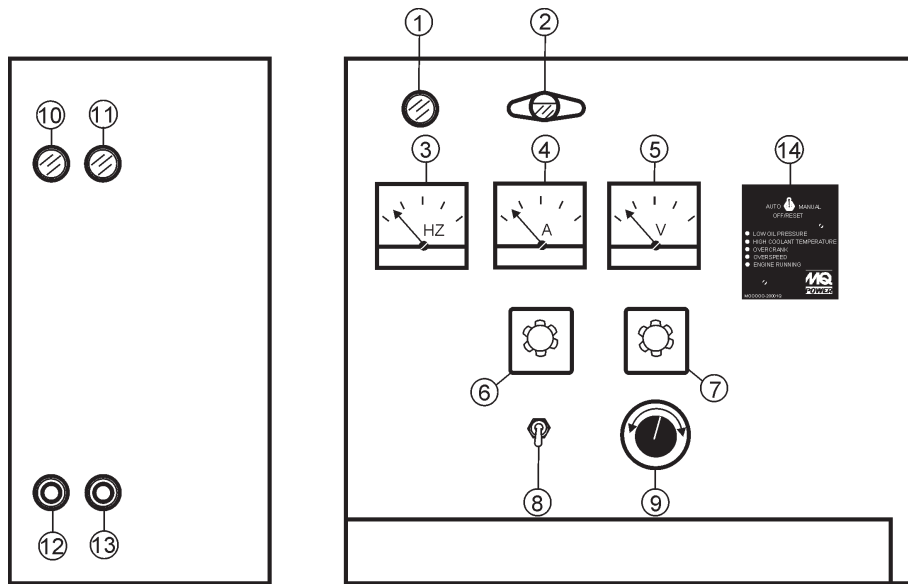

Figure 4. Generator Control Panel

The definitions below describe the controls and functions of the DCA800SSK2 Generator Control Panel (Figure 4).

1. **AC Voltmeter** — Indicates the output voltage present at the **U,V, and W Output Terminal Lugs**.
2. **Pilot Lamp** — Indicates the system is running.
3. **Panel Light** — Normally used in dark areas or at night time. When activated, panel lights will illuminate. When the generator is not in use be sure to turn the panel light switch to the **OFF** position.
4. **Frequency Meter** — Indicates the output frequency in hertz (Hz). Normally 60 Hz.
5. **AC Ammeter** — Indicates the amount of current the load is drawing from the generator per leg selected by the ammeter phaseselector switch.
6. **Voltmeter ChangeOver Switch** — This switch allows the AC voltmeter to indicate phase to phase voltage between any two phases of the output terminals or to be switched off.
7. **Panel Light Switch** — When activated will turn on control panel light.
8. **Voltage Regulator Control** — Allows $\pm 15\%$ manual adjustment of the generator's output voltage.
9. **Ammeter ChangeOver Switch** — This switch allows the AC ammeter to indicate the current flowing to the load connected to any phase of the output terminals, or to be switched off. This switch does not effect the generator output in any fashion, it is for current reading only.
10. **Circuit Breaker (ON) Switch**— Press this switch to place the 2500 amp circuit breaker in the closed (ON) position.
11. **Circuit Breaker (OFF) Switch**— Press this switch to place the 2500 amp circuit breaker in the open (OFF) position.
12. **Circuit Breaker (ON) Lamp**—When the circuit breaker ON switch is placed in the ON position this lamp will be turned ON.
13. **Circuit Breaker (OFF) Lamp** — When the circuit breaker ON switch is placed in the OFF position this lamp will be turned ON.

GENERATOR CONTROL PANEL

14. **Auto On/Off Engine Controller (MPEC)** — This controller has a vertical row of status LED's (inset), that when lit, indicate that an engine malfunction (fault) has been detected. When a fault has been detected the engine controller will evaluate the fault and all major faults will shutdown the generator. During **cranking cycle**, The MPEC will attempt to crank the engine for 10 seconds before disengaging.

If the engine does not engage (start) by the third attempt, the engine will be shutdown by the engine controller's **Over Crank Protection** mode. If the engine engages at a speed (RPM's) that is not safe, the controller will shutdown the engine by initializing the **Over Speed Protection** mode.



Also the engine controller will shut down the engine in the event of low oil pressure, high coolant temperature, low coolant level, and loss of magnetic pickup. These conditions can be observed by monitoring the LED status indicators on the front of the controller module.

■ **MPEC Control Switch** — This switch controls the running of the unit. If this switch is set to the **OFF/RESET** position, the unit will not run. When this switch is set to the manual position, the generator will start immediately.

If the generator is to be connected to a building's AC power source via a transfer switch (isolation), place the switch in the AUTO position. In this position, should an outage occur, the automatic transfer switch (ATS) will start the generator automatically via the generator's autostart contacts connected to the ATS's start contacts. Please refer to your ATS installation manual for further instructions for the correct installation of the autostart contacts of the generator to the ATS.

■ **Low Oil Pressure** — Indicates the engine pressure has fallen below a safe operating level. The oil pressure is detected using variable resistive values from the oil pressure sending unit. This is considered a **major** fault.

■ **High Coolant Temperature** — Indicates the engine temperature has exceeded a safe operating level. The engine temperature is detected using variable resistive values from the temperature sending unit. This is considered a **major** fault.

■ **Overcrank Shutdown** — Indicates the unit has attempted to start a pre programmed number of times and has failed to start. The number of cycles and duration are programmable. It is preset at 3 cycles with a 10second duration. This is considered a **major** fault.

■ **Overspeed Shutdown** — Indicates the engine is running at an unsafe speed. This is considered a **major** fault.

■ **Engine Running** — Indicates that engine is running at a safe operating speed.

Located behind the generator control panel is the **Generator Control Box**. This box contains some of the necessary electronic components required to make the generator function.

The **Control Box** is equipped with the following major components:

- OverCurrent Relay
- Voltage Rectifier (AVR)
- Starter Relay
- Current Transformer
- Voltage ChangeOver Board
- Three Phase Circuit Breaker

NOTICE

Remember the **overcurrent relay** monitors the current flowing from the **U,V, and W Output Terminal Lugs** to the load.

In the event of a short circuit or over current condition, it will automatically trip the 2500 amp main breaker.

To restore power to the **Output Terminal Panel**, press the reset button on the overcurrent relay and place the **main** circuit breaker in the **closed** position (**ON**).

ENGINE OPERATING PANEL

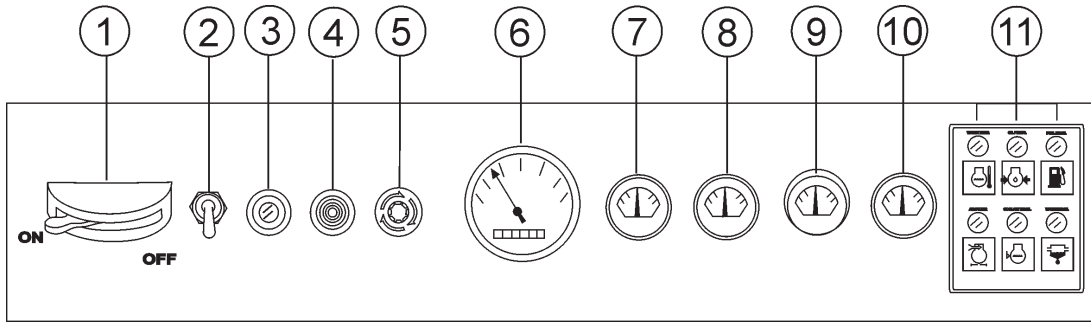







Figure 5. Engine Operating Panel

The definitions below describe the controls and functions of the DCA800SSK2 Engine Operating Panel (Figure 5).

1. **Battery Switch** — This switch should be set to the **ON** position during normal operation. When the engine has been stop, place this switch in the **OFF** position. **DO NOT** turn this switch during normal operation, it could cause damage to the electrical equipment.
2. **Engine Speed Switch** — This switch controls the speed of the engine (low/high).
3. **PreHeat Lamp** — When ECU is placed in **AUX** position, preheat lamp will be **ON**. When preheat cycle is completed, lamp will turn **OFF**.
4. **PreHeat Button** — Push this button when the engine is ready for starting during cold weather operating conditions. Keep pushing until the preheat lamp is off.
5. **Emergency Stop Button** — Push this button inward to stop the engine in the event of an emergency. **DO NOT** use this button as a means of stopping the engine.
6. **Tachometer** — Indicates engine speed in RPM's for 60 Hz operation. This meter should indicate 1800 RPM's when the rated load is applied. In addition a built in hour meter will record the number of operational hours that the generator has been in use.
7. **Oil Pressure Gauge** — During normal operation this gauge be should read between 28 to 85 psi. (193~586 kPa). When starting the generator the oil pressure may read a little higher, but after the engine warms up the oil pressure should return to the correct pressure range.
8. **Water Temperature Gauge** — During normal operation this gauge be should read between 167° and 203°F (75°~95°C).
9. **Charging Ammeter Gauge** — Indicates the current being supplied by the engine's alternator which provides current for generator's control circuits and battery charging system.
10. **Fuel Gauge** — Indicates amount of diesel fuel available.
11. **Engine Warning Lamps** — There are six engine warning lamps, they are defined as follows:
 - a. **Overheat Lamp** — This lamp goes **ON** when the cooling water temperature rises abnormally. If the lamp goes **ON** during normal operation of the generator, the emergency shutdown device will stop the engine automatically.  WATER TEMP.
 - b. **Low Oil Pressure Lamp** — During normal operation of the generator this lamp should remain **OFF**. When the **AutoOFF/ResetManual** switch is set to the **MANUAL** position to start the engine, the lamp will be lit. When the oil pressure rises after startup the lamp will go **OFF**. If this lamp is ever lit (**ON**) during normal operation of the generator, the emergency shutdown device will stop the engine automatically.  OIL PRESS.
 - c. **Low Fuel Level Lamp** — When this lamp is **ON**, it is time to stop the engine and add fuel. Remember to let the engine cool before adding fuel.  FUEL LEVEL
 - d. **Air Filter Alarm** — When the air filter element is clogged, this lamp goes **ON** indicating the element should be immediately cleaned or replaced.  AIR FILTER
 - e. **Oil Filter Alarm** — This lamp goes **ON** when the coolant level is low. If this lamp goes **ON** while the engine is in operation, the emergency shutdown device will automatically stop the engine.  COOLANT LEVEL
 - f. **Water Level Lamp** — This lamp goes **ON** when the coolant level is low. If this lamp goes **ON** while the engine is in operation, the emergency shutdown device will automatically stop the engine.  WATER LEVEL

OUTPUT TERMINAL PANEL FAMILIARIZATION

OUTPUT TERMINAL PANEL

The Output Terminal Panel (Figure 6) shown below is located on the righthand side (left from control panel) of the generator. Lift up on the cover to gain access to receptacles and terminal lugs.

NOTICE

Terminal legs "O" and "Ground" are considered bonded grounds.

OUTPUT TERMINAL FAMILIARIZATION

The "Output Terminal Panel" (Figure 6) is provided with the following:

- Three (3) 120/240V output receptacles @ 50 amp
- Three (3) Circuit Breakers @ 50 amps
- Eight (8) Output Terminal Lugs (U, V, W, O, Ground)

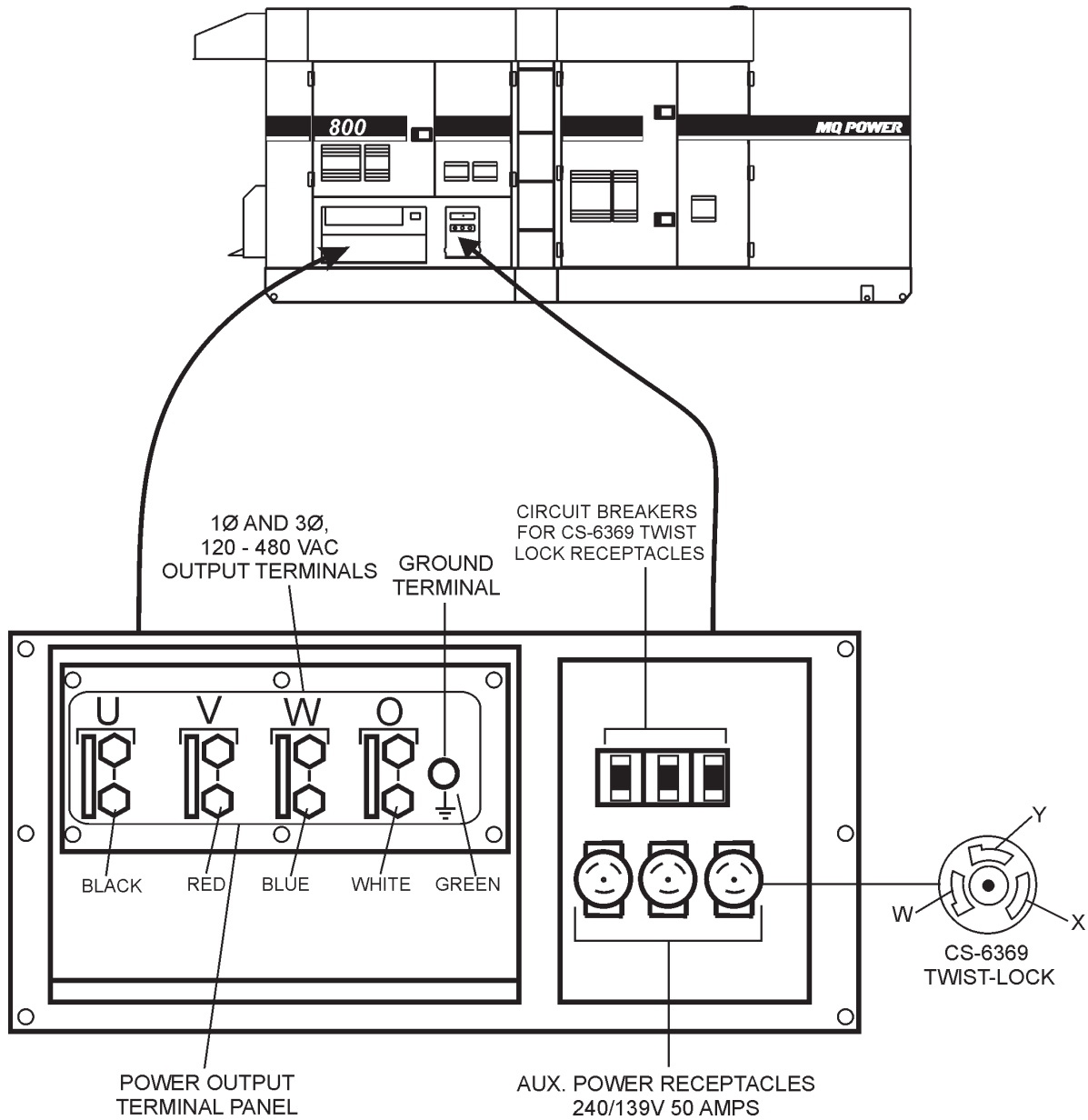

Figure 6. Output Terminal Panel

OUTPUT TERMINAL PANEL FAMILIARIZATION

Twist Lock Dual Voltage 240/139 VAC Receptacles

There are three 240/139V, 50 amp auxiliary twistlock (CS6369) receptacles (Figure 7) provided on the output terminal panel..

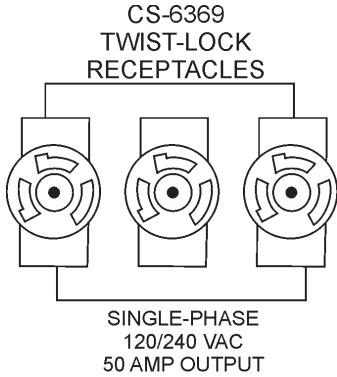

Figure 7. 240/139V TwistLock Auxiliary Receptacles

Each auxiliary receptacle is protected by a 50 amp circuit breaker. These breakers are located directly above the auxiliary receptacles. Remember the load output (current) on all three receptacles is dependent on the load requirements of the **Output Terminal Lugs**.

Turn the **voltage regulator control knob** (Figure 8) on the control panel to obtain the desired voltage. Turning the knob clockwise will **increase** the voltage, turning the knob counterclockwise will **decrease** the voltage.



Figure 8. Voltage Regulator Control Knob

Connecting Loads

Loads can be connected to the generator by the **Output Terminal Lugs** or the convenience receptacles (Figure 9). Make sure to read the operation manual before attempting to connect a load to the generator.

To protect the output terminals from overload, a 3pole, 2500A **main** circuit breaker is provided. Make sure to switch **ALL** circuit breakers to the **OFF** position prior to starting the engine.

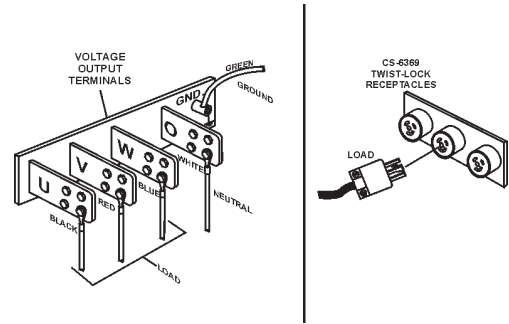

Figure 9. Connecting Loads

Over Current Relay

An **over current relay** (Figure 10) is connected to the main circuit breaker. In the event of an overload, both the circuit breaker and the over current relay may trip. If the circuit breaker can not be reset, the **reset button** on the over current relay must be pressed. The over current relay is located in the control box.

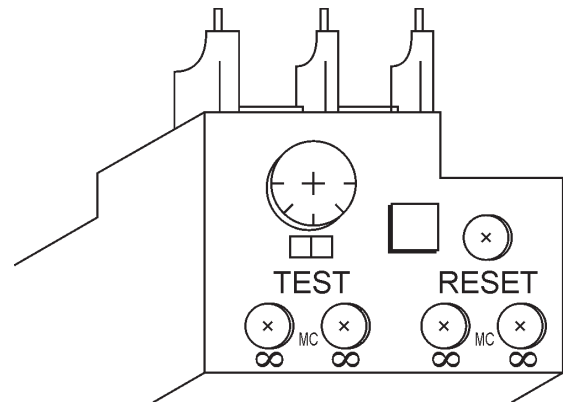

Figure 10. Over Current Relay

LOAD APPLICATION

SINGLE PHASE LOAD

Always be sure to check the nameplate on the generator and equipment to insure the wattage, amperage, frequency, and voltage requirements are satisfactorily supplied by the generator for operating the equipment.

Generally, the wattage listed on the nameplate of the equipment is its rated output. Equipment may require 130—150% more wattage than the rating on the nameplate, as the wattage is influenced by the efficiency, power factor and starting system of the equipment.

NOTICE

If wattage is not given on the equipment's name plate, approximate wattage may be determined by multiplying nameplate voltage by the nameplate amperage.

$$\text{WATTS} = \text{VOLTAGE} \times \text{AMPERAGE}$$

The power factor of this generator is 0.8. See Table 5 below when connecting loads.

Table 5. Power Factor By Load

Type of Load	Power Factor
Singlephase induction motors	0.40.75
Electric heaters, incandescent lamps	1.0
Fluorescent lamps, mercury lamps	0.40.9
Electronic devices, communication equipment	1.0
Common power tools	0.8

Table 6. Cable Selection (60 Hz, Single Phase Operation)

Current in Amperes	Load in Watts		Maximum Allowable Cable Length			
	At 100 Volts	At 200 Volts	#10 Wire	#12 Wire	#14 Wire	#16 Wire
2.5	300	600	1000 ft.	600 ft.	375 ft.	250 ft.
5	600	1200	500 ft.	300 ft.	200 ft.	125 ft.
7.5	900	1800	350 ft.	200 ft.	125 ft.	100 ft.
10	1200	2400	250 ft.	150 ft.	100 ft.	
15	1800	3600	150 ft.	100 ft.	65 ft.	
20	2400	4800	125 ft.	75 ft.	50 ft.	

CAUTION: Equipment damage can result from low voltage

THREE PHASE LOAD

When calculating the power requirements for 3phase power use the following equation:

$$\text{KVA} = \frac{\text{VOLTAGE} \times \text{AMPERAGE} \times 1.732}{1000}$$

NOTICE

If 3Ø load (kVA) is not given on the equipment nameplate, approximate 3Ø load may be determined by multiplying voltage by amperage by 1.732.

NOTICE

Motors and motordriven equipment draw much greater current for starting than during operation.

An inadequate size connecting cable which cannot carry the required load can cause a voltage drop which can burn out the appliance or tool and overheat the cable. See Table 6.

- When connecting a resistance load such as an incandescent lamp or electric heater, a capacity of up to the generating set's rated output (kW) can be used.
- When connecting a fluorescent or mercury lamp, a capacity of up to the generating set's rated output (kW) multiplied by 0.6 can be used.
- When connecting an electric drill or other power tools, pay close attention to the required starting current capacity.

When connecting ordinary power tools, a capacity of up to the generating set's rated output (kW) multiplied by 0.8 can be used.

DANGER

Before connecting this generator to any building's electrical system, a **licensed electrician** must install an **isolation (transfer) switch**. Serious damage to the building's electrical system may occur without this transfer switch.

GENERATOR OUTPUTS

GENERATOR OUTPUT VOLTAGES

A wide range of voltages are available to supply voltage for many different applications. Voltages are selected by applying jumpers (6) to the **voltage changeover board** (Figure 11). To obtain some of the voltages as listed in Table 7 (see below) will require a fine adjustment using the **voltage regulator (VR) control knob** located on the control panel.

Voltage ChangeOver Board

The **voltage changeover board** (Figure 11) is located on the control box, behind the generator control panel. This board has been provided for ease of voltage selection.

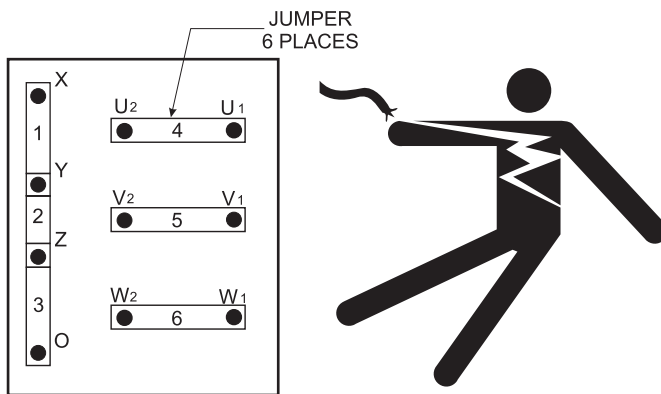

Figure 11. Voltage ChangeOver Board

CAUTION

NEVER attempt to place jumper plates on the **voltage changeover board** while the generator is in operation. There exist the possibility of **electrocution, electrical shock or burn, which can cause severe bodily harm or even death!**

Table 7. Voltages Available

Three Phase (Switchable)	208V	220V	240V	416V	440V	480V
Single Phase (Switchable)	120V	1127V	139V	240V	254V	277V

Generator Amperage

Table 8 shows the **maximum** amps the generator can provide. **DO NOT** exceed the maximum amps as listed.

Table 8. Generator Maximum Amps

Rated Voltage	Maximum Amps
1Ø 120 Volt	1777.8 amps (4 wire)
1Ø 240 Volt	888.9 amps (4 wire)
3Ø 240 Volt	1924.6 amps
3Ø 480 Volt	962.3 amps

GENERATOR OUTPUTS/GAUGE READING

HOW TO READ THE AC AMMETER AND AC VOLTAGE GAUGES

The AC ammeter and AC voltmeter gauges are controlled by the AC ammeter and AC voltmeter changeover switches.

Both of these switches are located on the control panel and **DO NOT** effect the generator output. They are provided to help observe how much power is being supplied, produced at the UVWO terminals lugs.

Before taking a reading from either gauge, configure the **Voltage ChangeOver Board** (Figure 12) which produces the desired output voltage.

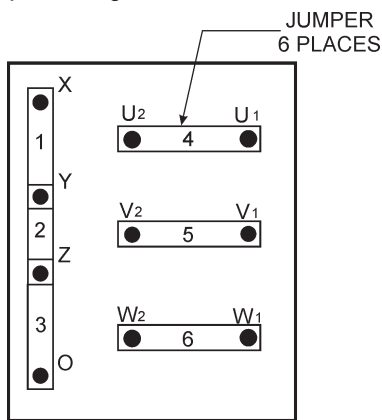

Figure 12. Voltage ChangeOver Board
240/3Ø Position

AC Voltmeter Gauge Reading

Place the **AC Voltmeter ChangeOver Switch** (Figure 13) in the WU position and observe the phase to phase voltage reading between the W and U terminals as indicated on the **AC Voltmeter Gauge** (Figure 14).

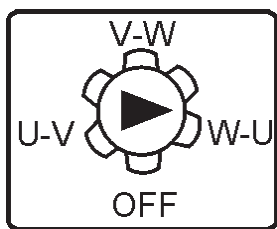

Figure 13. AC Voltmeter
ChangeOver Switch

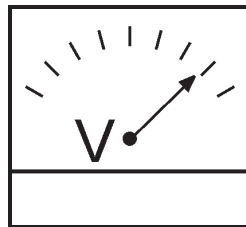

Figure 14. AC Voltmeter Gauge
(Volt reading on WU Lug)

AC Ammeter Gauge Reading

Place the **AC Ammeter ChangeOver Switch** (Figure 15) in the U position and observe the current reading (load drain) on the U terminal as indicated on the **AC Ammeter Gauge** (Figure 16). This process can be repeated for terminals V and W.

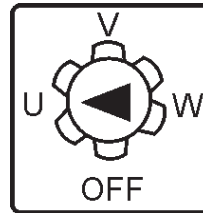

Figure 15. AC Ammeter
ChangeOver Switch

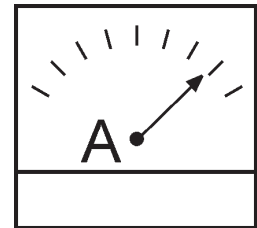

Figure 16. AC Ammeter
(Amp reading on U Lug)

NOTICE

The **ammeter** gauge will only show a reading when the **Output Terminal Lugs** are connected to a load and in use.

OUTPUT TERMINAL PANEL CONNECTIONS

UVWO TERMINAL OUTPUT VOLTAGES

Various output voltages can be obtained using the UVWO output terminal lugs. The voltages at the terminals are dependent on the placement of the jumpers plates (6) on the **Voltage ChangeOver Board** (Figure 17) and the adjustment of the **Voltage Regulator Control Knob**.

Remember the voltage changeover board determines the **range** of the output voltage and can be configured in two different positions that provide 6 different output voltages at the UVWO output terminals. The generator is shipped from the factory in the 240V configuration. The voltage regulator (VR) allows the user to increase or decrease the selected voltage.

3Ø-240V UVWO Terminal Output Voltages

1. Jumper the voltage changeover board for 240V operation as shown in Figure 17.

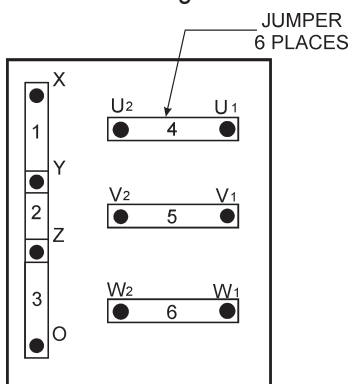

Figure 17. Voltage ChangeOver Board 240V Configuration

2. Connect the load wires to the UVWO terminals as shown in Figure 18.

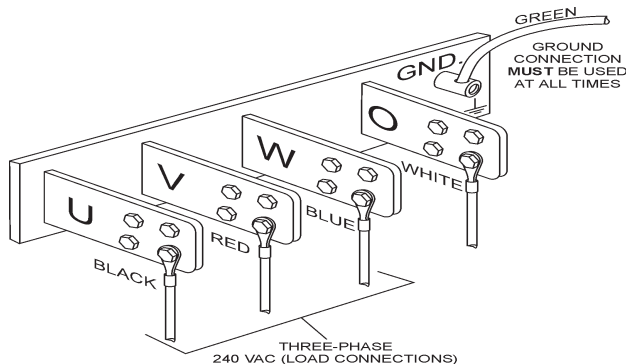

Figure 18. UVWO Terminal Lugs

3. Turn the voltage regulator knob (Figure 19) clockwise to increase voltage output, turn counterclockwise to decrease voltage output. Use voltage regulator adjustment knob whenever fine tuning of the output voltage is required



Figure 19. Voltage Regulator Knob

1Ø-240V UVWO Terminal Output Voltages

1. Make sure the voltage changeover board is jumpered for 240V operation as shown in Figure 17.
2. Connect the load wires to the UVWO terminals as shown in Figure 20.

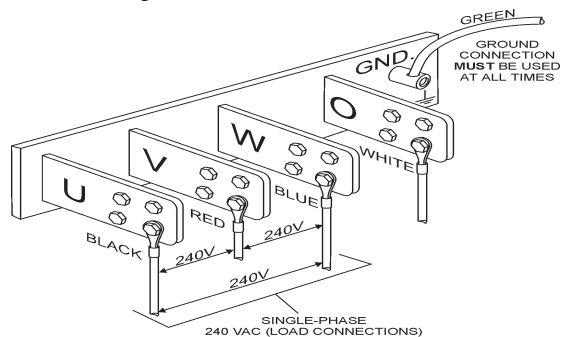

Figure 20. UVWO Terminal Lugs 1Ø240V Connections

1Ø-120V UVWO Terminal Output Voltages

1. Make sure the voltage changeover board is jumpered for 240V operation as shown in Figure 17.
2. Adjust voltage regulator knob (Figure 19) for an output of 208V to obtain 120V at the UVWO terminals.
3. Connect the load wires to the UVWO terminals as shown in Figure 21.

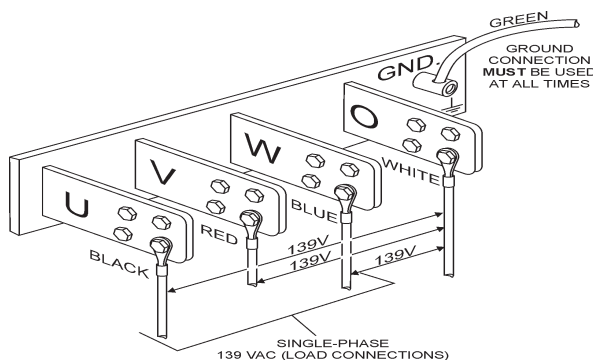

Figure 21. UVWO Terminal Lugs 1Ø139V Connections

OUTPUT TERMINAL PANEL CONNECTIONS

3Ø-480V UVWO Terminal Output Voltages

1. Jumper the voltage changeover board for 480V operation as shown in Figure 22. This configuration uses 6 jumper plates in 3 different positions. Remember there are 2 jumper plates at every position. Every jumper plate **must** be used.

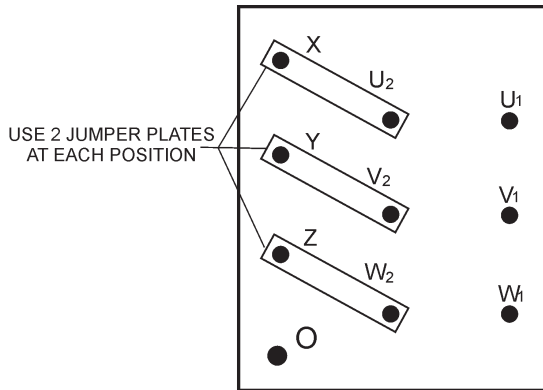

Figure 22. Voltage ChangeOver Board 480V Configuration

2. Connect the load wires to the UVWO terminals as shown in Figure 23.

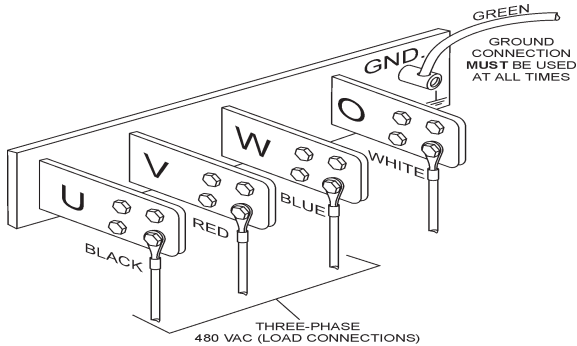

Figure 23. UVWO Terminal Lugs 3Ø480V Connections

NOTICE

ALWAYS make sure that the connections to the UVWO terminals are **secure** and **tight**. The possibility of arcing exists, that could cause a fire.

1Ø-480V UVWO Terminal Output Voltages

1. Make sure the voltage changeover board is jumpered for 480V operation as shown in Figure 22.
2. Connect the load wires to the UVWO terminals as shown in Figure 24.

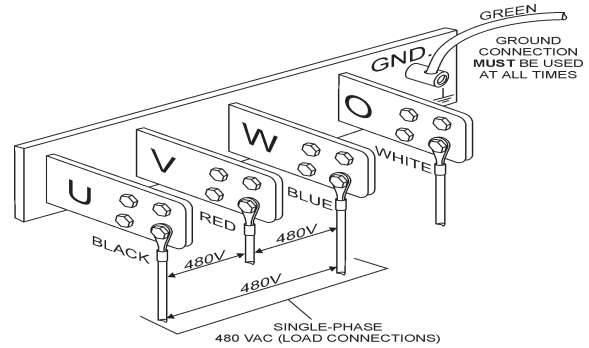

Figure 24. UVWO Terminal Lugs 1Ø480V Connections

1Ø-277V UVWO Terminal Output Voltages

1. Make sure the voltage changeover board is jumpered for 480V operation as shown in Figure 22.
2. Connect the load wires to the UVWO terminals as shown in Figure 25.

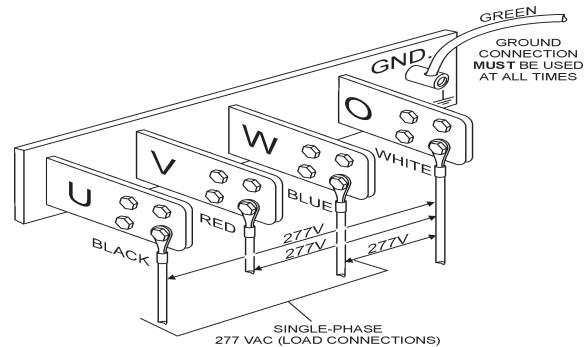

Figure 25. UVWO Terminal Lugs 1Ø277V Connections

CIRCUIT BREAKERS

To protect the generator from an overload, a 3pole, 2500 amp, main circuit breaker is provided to protect the **U,V, and W Output Terminals** from overload. In addition, three 50 amp **load** circuit breakers have been provided to protect the auxiliary receptacles from overload. Make sure to switch **ALL** circuit breakers to the **OFF** position prior to starting the engine.

LUBRICATION OIL

Fill the engine crankcase with lubricating oil through the filler hole, but **DO NOT** overfill. Make sure the generator is level and verify that the oil level is maintained between the two notches (Figure 26) on the dipstick. See Table 11 for proper selection of engine oil.

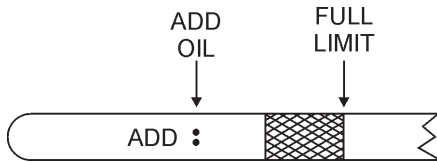

Figure 26. Engine Oil Dipstick

When checking the engine oil, be sure to check if the oil is clean. If the oil is not clean, drain the oil by removing the oil drain plug, and refill with the specified amount of oil as outlined in the **Komatsu Engine Owner's Manual**. Oil should be warm before draining.

Other types of motor oils may be substituted if they meet the following requirements:

- API Service Classification CC/SC
- API Service Classification CC/SD
- API Service Classification CC/SE
- API Service Classification CC/SF

Table 9. Recommended Motor Oil		OIL: SAE	
°F	°C		
122	50	10W/40	10W/40
104	40	30	15W/30
86	30	ARCTIC OIL	10W/30
68	20	5W/30	10W
50	10		20W/40
32	0		
-14	-10		
-4	-20		
-22	-30		
-40	-40		

FUEL CHECK

! DANGER

Fuel spillage on a **hot** engine can cause a **fire** or **explosion**. If fuel spillage occurs, wipe up the spilled fuel completely to prevent fire hazards. **NEVER** smoke around or near the generator.

Refilling the Fuel System

! CAUTION

ONLY properly trained personnel who have read and understand this section should refill the fuel tank system.

This generator has an internal fuel tank located inside the trailer frame and may also be equipped with an environmental fuel tank (Figure 27). **ALWAYS** fill the fuel tanks with clean fresh **#2 diesel fuel**. **DO NOT** fill the fuel tanks beyond their capacities.

Pay attention to the fuel tank capacity when replenishing fuel. The fuel tank cap must be closed tightly after filling. Handle fuel in a safety container. If the container does not have a spout, use a funnel. Wipe up any spilled fuel immediately.

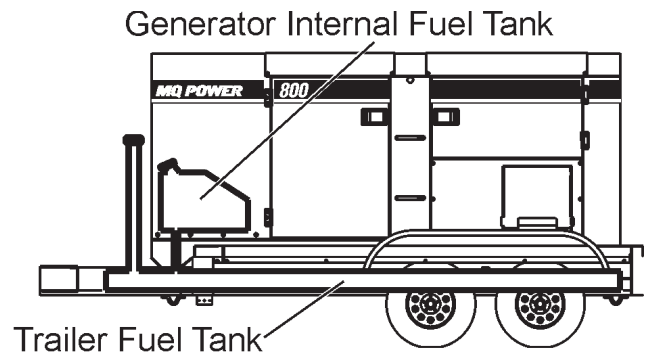

Figure 27. Internal Fuel Tank System

INSPECTION/SETUP

Refueling Procedure:

WARNING



Diesel fuel and its vapors are dangerous to your health and the surrounding environment. Avoid skin contact and/or inhaling fumes.

1. **Level Tanks** — Make sure fuel cells are level with the ground. Failure to do so will cause fuel to spill from the tank before reaching full capacity (Figure 28).

CAUTION

ALWAYS place trailer on firm level ground before refueling to prevent spilling and maximize the amount of fuel that can be pumped into the tank.

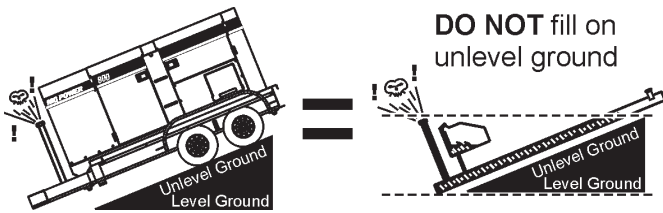

Figure 28. Only Fill on Level Ground

NOTICE

ONLY use #2 diesel fuel when refueling.

2. Open cabinet doors on the “right side” of the generator (from generator control panel position). Remove fuel cap and fill tank (Figure 29).

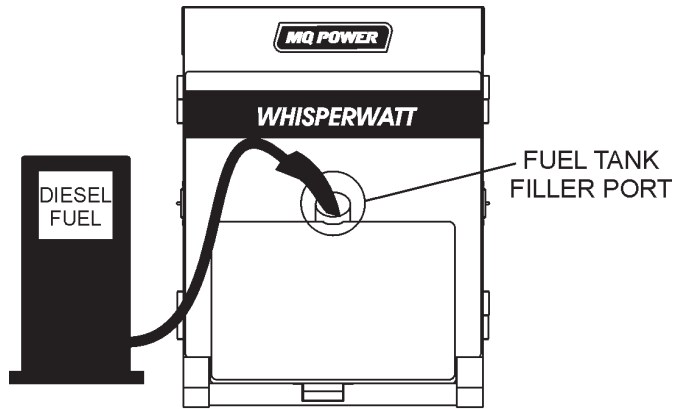

Figure 29. Fueling the Generator

3. **NEVER overfill fuel tank** — It is important to read the fuel gauge when filling trailer fuel tank. **DO NOT** wait for fuel to rise in filler neck (Figure 30).

FUEL GAUGE LOCATED ON CONTROL PANEL

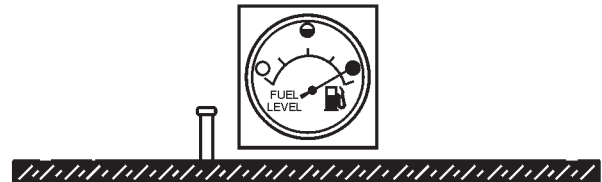

Figure 30. Full Fuel Tank

CAUTION

DO NOT OVERFILL fuel system. Leave room for fuel expansion. Fuel expands when heated (Figure 31).



Figure 31. Fuel Expansion

COOLANT (ANTIFREEZE/SUMMER COOLANT/WATER)

Komatsu recommends antifreeze/summer coolant for use in their engines, which can be purchased in concentrate (and mixed with 50% demineralized water) or prediluted. See the **Komatsu Engine Owner's Manual** for further details.

! WARNING



If adding coolant/antifreeze mix to the radiator, **DO NOT** remove the radiator cap until the unit has completely cooled. The possibility of **hot!** coolant exists which can cause severe burns.

Daytoday addition of coolant is done from the recovery tank. When adding coolant to the radiator, **DO NOT** remove the radiator cap until the unit has completely cooled. See Table 10 for engine, radiator, and recovery tank coolant capacities. Make sure the coolant level in the recovery tank is always between the "H" and the "L" markings.

Table 10. Coolant Capacity	
Engine and Radiator	40.4 gal (153.0 liters)
Reserve Tank	N/A

Operation in Freezing Weather

When operating in freezing weather, be certain the proper amount of antifreeze (Table 11) has been added.

Table 11. AntiFreeze Operating Temperatures		
Vol % AntiFreeze	Freezing Point	
	°C	°F
50	37	34

NOTICE

When the antifreeze is mixed with water, the antifreeze mixing ratio **must be** less than 50%.

CLEANING THE RADIATOR

The engine may overheat if the radiator fins become overloaded with dust or debris. Periodically clean the radiator fins with compressed air. Cleaning inside the machine is dangerous, so clean only with the engine turned off and the **negative** battery terminal disconnected.

AIR CLEANER

Periodic cleaning/replacement is necessary. Inspect it in accordance with the **Komatsu Engine Owner's Manual**.

FAN BELT TENSION

A slack fan belt may contribute to overheating, or to insufficient charging of the battery. Inspect the fan belt for damage and wear and adjust it in accordance with the **Komatsu Engine Owner's Manual**.

The fan belt tension is proper if the fan belt bends 10 to 15 mm (Figure 32) when depressed with the thumb as shown below.

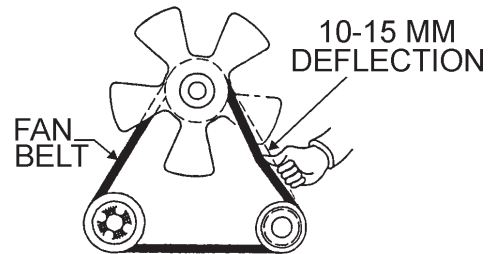



Figure 32. Fan Belt Tension

! CAUTION



NEVER place hands near the belts or fan while the generator set is running.

BATTERY

This unit is of negative ground **DO NOT** connect in reverse. Always maintain battery fluid level between the specified marks. Battery life will be shortened, if the fluid level are not properly maintained. Add only distilled water when replenishment is necessary.

DO NOT over fill. Check to see whether the battery cables are loose. Poor contact may result in poor starting or malfunctions. **Always** keep the terminals firmly tightened. Coating the terminals with an approved battery terminal treatment compound. Replace battery with only recommended type battery.

The battery is sufficiently charged if the specific gravity of the battery fluid is 1.28 (at 68° F). If the specific gravity should fall to 1.245 or lower, it indicates that the battery is dead and needs to be recharged or replaced.

Before charging the battery with an external electric source, be sure to disconnect the battery cables.

Battery Cable Installation

ALWAYS be sure the battery cables (Figure 33) are properly connected to the battery terminals as shown below. The **red cable** is connected to the positive terminal of the battery, and the **black cable** is connected to the negative terminal of the battery.

CAUTION

ALWAYS disconnect the negative terminal **FIRST** and reconnect negative terminal **LAST**.

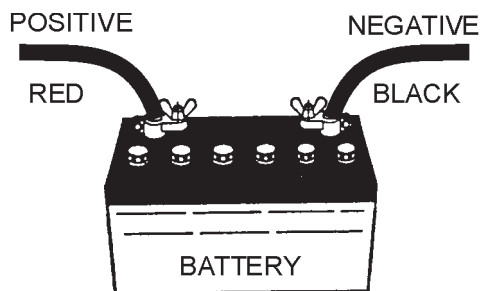

Figure 33. Battery Connections

When connecting battery do the following:

1. **NEVER** connect the battery cables to the battery terminals when the **MPEC Control Switch** is in either the **MANUAL** position. **ALWAYS** make sure that the **MPEC Control Switch** is in the **OFF/RESET** position when connecting the battery.
2. Place a small amount of battery terminal treatment compound around both battery terminals. This will ensure a good connection and will help prevent corrosion around the battery terminals.

NOTICE

If the battery cable is connected incorrectly, electrical damage to the generator will occur. Pay close attention to the polarity of the battery when connecting the battery.

CAUTION

Inadequate battery connections may cause poor starting of the generator, and create other malfunctions.

ALTERNATOR

The polarity of the alternator is negative grounding type. When an inverted circuit connection takes place, the circuit will be in short circuit instantaneously resulting the alternator failure.

DO NOT put water directly on the alternator. Entry of water into the alternator can cause corrosion and damage the alternator.

WIRING

Inspect the entire generator for bad or worn electrical wiring or connections. If any wiring or connections are exposed (insulation missing) replace wiring immediately.

PIPING AND HOSE CONNECTION

Inspect all piping, oil hose, and fuel hose connections for wear and tightness. Tighten all hose clamps and check hoses for leaks.

If any hose (**fuel or oil**) lines are defective replace them immediately.

GENERATOR STARTUP PROCEDURE (MANUAL)

BEFORE STARTING

CAUTION

The engine's exhaust contains harmful emissions. **ALWAYS** have adequate ventilation when operating. Direct exhaust away from nearby personnel.

WARNING

NEVER manually start the engine with the **main, or auxiliary** circuit breakers in the **ON** (closed) position.

If applicable perform the following:

- Apply commercial power to the internal battery charger receptacle (to ensure good starting) via commercial power. An external power cord will be required. This capability is an *option*.
- Apply commercial power to the jacket water heater receptacle (not necessary for warm climates) via commercial power. An external power cord will be required. This capability is an *option*.

1. Press the main circuit breaker "OFF" switch (Figure 34).

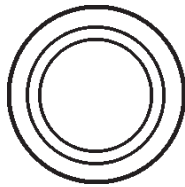

Figure 34. Main Circuit Breaker OFF Switch

2. Verify that the **main** circuit breaker "OFF" lamp (Figure 35) is lit (ON).



Figure 35. Main Circuit Breaker OFF Lamp

3. Place the three **auxiliary** circuit breakers (Figure 36) in the **OFF** position prior to starting the engine.

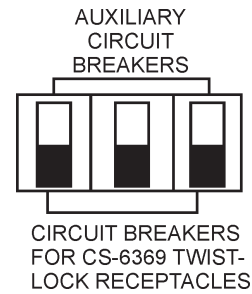

Figure 36. Auxiliary Circuit Breakers (OFF)

4. Connect the load to the UVWO terminals or auxiliary receptacles as shown in Figure 37. These load connection points can be found on the output terminal panel. To gain access to the UVWO busbar terminals or other power receptacles, unlock the access cover and lift the door.

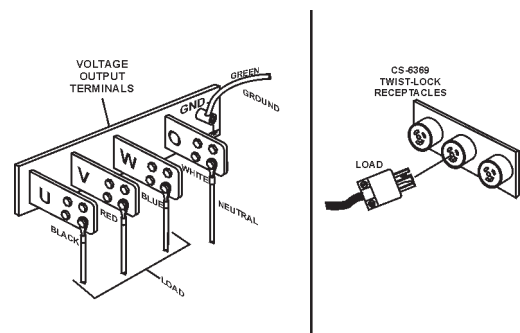

Figure 37. Load Connections

5. Tighten the UVWO terminal nuts securely to prevent load wires from slipping out.
6. Close all engine enclosure doors (Figure 38).

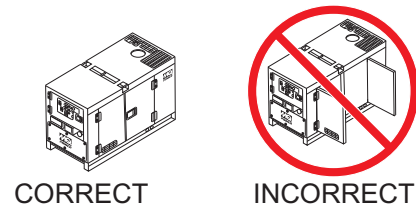

Figure 38. Engine Enclosure Doors

GENERATOR STARTUP PROCEDURE (MANUAL)

STARTING (MANUAL)

1. Set the **battery ON/OFF switch** (Figure 39) to the "ON" position.

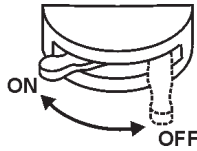

Figure 39. Battery Switch (ON)

2. Place the **engine speed switch** in the "LOW" position (Figure 40).



Figure 40. Engine Speed Switch (Low)

3. Place the **MPEC control switch** in the **MANUAL** position to start the engine (Figure 41).



Figure 41. MPEC Control Switch (Manual Position)

4. Press and hold the engine pre-heat button (Figure 42). Verify that the pre-heat lamp is lit. Continue pressing button until pre-heat cycle is complete. After completion of the pre-heating cycle, the light will go OFF and the engine will start up automatically.

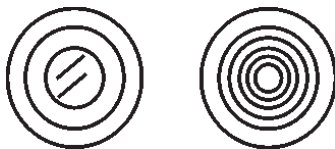

Figure 42. Pre-Heat Lamp/Pre-Heat Button

5. Once the engine starts, let the engine run for 12 minutes. Listen for any abnormal noises. If any abnormalities exist, shut down the engine and correct the problem. If the engine is running smoothly, place the engine speed switch (Figure 43) in the **HIGH** (up) position.



Figure 43. Engine Speed Switch (High)

6. The generator's frequency meter (Figure 44) should be displaying the 60 cycle output frequency in **HERTZ**.

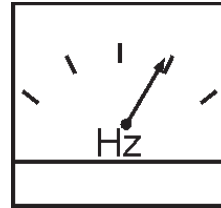

Figure 44. Frequency Meter

7. The generator's AC voltmeter (Figure 45) will display the generator's output in **VOLTS**.

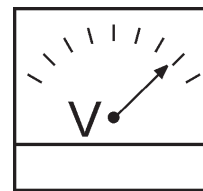

Figure 45. Voltmeter

8. If the voltage is not within the specified tolerance, use the voltage adjustment control knob (Figure 46) to increase or decrease the desired voltage.



Figure 46. Voltage Adjust Control Knob

9. Verify that the **engine running** status LED on the MPEC module (Figure 47) is lit (ON) after the engine has started.



Figure 47. Engine Running LED (ON)

10. The ammeter (Figure 48) will indicate **zero amps** with no load applied. When a load is applied, the ammeter will indicate the amount of current that the load is drawing from the generator.

GENERATOR STARTUP PROCEDURE (MANUAL)

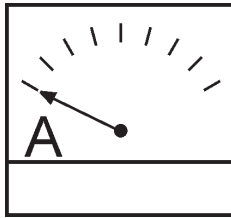

Figure 48. Ammeter (No Load)

11. The engine oil pressure gauge (Figure 49) will indicate the oil pressure of the engine. Under normal operating conditions the oil pressure is approximately 28 to 85 psi. (193~586 kPa).

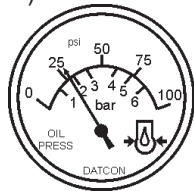

Figure 49. Oil Pressure Gauge

12. The coolant temperature gauge (Figure 50) will indicate the coolant temperature. Under normal operating conditions the coolant temperature should be between 167°~203°F (75°~95°C) (**Green Zone**).

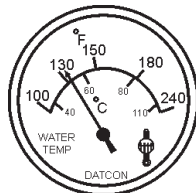

Figure 50. Coolant Temperature Gauge

13. The tachometer gauge (Figure 51) will indicate the speed of the engine when the generator is operating. Under normal operating conditions this speed is approximately 1800 RPM's.

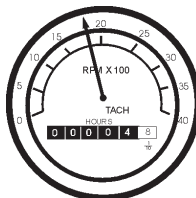

Figure 51. Engine Tachometer Gauge

14. Press the *main* circuit breaker "ON" switch (Figure 52).

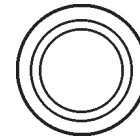

Figure 52. Main Circuit Breaker ON Switch

15. Verify that the main circuit breaker "ON" lamp (Figure 53) is lit (ON).

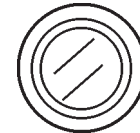

Figure 53. Main Circuit Breaker ON Lamp

16. Place the three **auxiliary** circuit breakers in the **ON** position (Figure 54).



CIRCUIT BREAKERS
FOR CS-6369 TWIST-
LOCK RECEPTACLES

**Figure 54. Main, Aux. and GFCI
Circuit Breakers (ON)**

17. Verify that the generator's ammeter (Figure 55) reads the anticipated amount of current with respect to the load. The ammeter will only display a current reading if a load is in use.

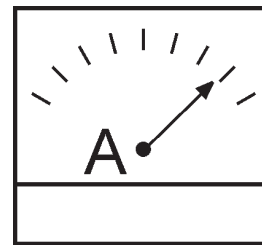

Figure 55. Ammeter (Load)

18. The generator will run until manually stopped or an abnormal condition occurs.

GENERATOR STARTUP PROCEDURE (AUTO MODE)

CAUTION

When connecting the generator to a isolation (transfer) switch, **ALWAYS** have power applied to the generator's internal battery charger. This will ensure that the engine will not fail due to a dead battery.

DANGER



Before connecting this generator to any building's electrical system, a **licensed electrician** must install an **isolation (transfer) switch**. Serious damage to the building's electrical system may occur without this transfer switch.

NOTICE

When the generator is set in the **AUTO** mode, the generator will **automatically start** in the event of commercial power falling below a prescribed level by means of a contact closure that is generated automatically by a transfer switch.

WARNING

When running the generator in the **AUTO** mode, remember the generator can start up at any time without warning. **NEVER** attempt to perform any maintenance when the generator is in the auto mode.

CAUTION

The engine speed switch **must** be set to the "High" position when running in the **autostart** mode. Failing to set the switch in the proper position can result in damage to your generator when it turns on.

NOTICE

When the MPEC control switch is placed in the **AUTO** position, the engine glow plugs will be warmed and the engine will start automatically.

STARTING (AUTO MODE)

When starting generator in **AUTO** mode use the "Manual Startup" procedure except where noted (see below).

1. Perform steps 1 through 4 in the Before Starting section as outlined in the Manual Starting Procedure.
2. Place the **engine speed switch** (Figure 56) in the **HIGH** position



Figure 56. Engine Speed Switch (High)

3. Place the **MPEC Control Switch** (Figure 57) in the **AUTO** position.



Figure 57. MPEC Control Switch (AUTO)

4. Continue operating the generator as outlined in the Manual Startup procedure (start at step 5).

GENERATOR SHUTDOWN PROCEDURES

NORMAL SHUTDOWN PROCEDURE

To shutdown the generator, use the following procedure:

1. Place the three **auxiliary** circuit breakers in the **OFF** position (Figure 36)
2. Place the engine speed switch (Figure 58) in the "LOW" (down) position.



Figure 58. Engine Speed Switch (Low)

3. Let the engine cool by running it at low speed for 3-5 minutes with no load applied.
4. Place the **MPEC Control Switch** (Figure 59) to the **OFF/RESET** position.



Figure 59. MPEC Control Switch (Off/Reset)

5. Verify that **all** the status LEDs on the MPEC display are **OFF** (not lit).
6. Set the **battery ON/OFF switch** (Figure 60) to the "**OFF**" position.

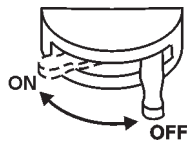

Figure 60. Battery Switch (OFF)

7. Remove all loads from the generator.
8. Inspect entire generator for any damage or loosening of components that may have occurred during operation.

EMERGENCY SHUTDOWN PROCEDURE

1. To stop the engine in the event of an emergency, **PUSH** the emergency stop button (Figure 61) inward. This button is located on the engine operating panel, see Figure 5.

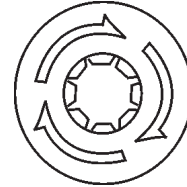

Figure 61. Emergency Stop Button

Table 12. Inspection/Maintenance		10 Hrs DAILY	250 Hrs	500 Hrs	1000 Hrs
Engine	Check Engine Fluid Levels	X			
	Check Air Cleaner	X			
	Check Battery Acid Level	X			
	Check Fan Belt Condition	X			
	Check for Leaks	X			
	Check for Loosening of Parts	X			
	Replace Engine Oil and Filter * 1		X		
	Clean Air Filter		X		
	Check Fuel Filter/Water Separator Bowl	X			
	Clean Unit, Inside and Outside		X		
	Change Fuel Filter			X	
	Clean Radiator and Check Coolant Protection Level*2			X	
	Replace Air Filter Element * 3			X	
	Check all Hoses and Clamps * 4				X
Clean Inside of Fuel Tank				X	
Generator	Measure Insulation Resistance Over 3M ohms		X		
	Check Rotor Rear Support Bearing			X	

*1 Replace engine oil and filter at 100 hours, first time only.

*2 Add "Supplemental Coolant Additives (SCA'S)" to recharge the engine coolant.

*3 Replace primary air filter element when restriction indicator shows a vacuum of 625 mm (25 in. H2O).

*4 If blowby hose needs to be replaced, ensure that the slope of the blowby hose is at least a 1/2 inch per foot, with no sags or dips that could collect moisture and/or oil.

GENERAL INSPECTION

Prior to each use, the generator should be cleaned and inspected for deficiencies. Check for loose, missing or damaged nuts, bolts or other fasteners. Also check for fuel, oil, and coolant leaks. Use Table 12 as a general maintenance guideline. **Engine Side**, refer to the Engine Instruction Manual.

AIR CLEANER

Every 250 hours: Remove air cleaner element (Figure 62) and clean the heavy duty paper element with light spray of compressed air. Replace the air cleaner as needed.

Air Cleaner with Dust Indicator

This indicator (Figure 62) is attached to the air cleaner. When the air cleaner element is clogged, air intake restriction becomes greater and the dust indicator signal shows **RED** meaning the element needs changing or service. After changing the air element, press the dust indicator button to reset the indicator.

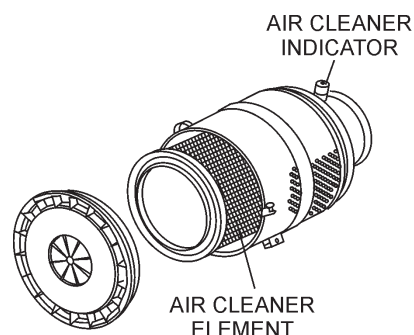

Figure 62. Air Cleaner/Indicator

NOTICE

The air filter should not be changed until the indicator reads "**RED**". Dispose of old air filter. It may not be cleaned or reused.

If the engine is operating in very **dusty** or **dry grass** conditions, a clogged air cleaner will result. This can lead to a loss of power, excessive carbon buildup in the combustion chamber and high fuel consumption. Change air cleaner more **frequently** if these conditions exist.

FUEL ADDITION

Add diesel fuel (the grade may vary according to season and locations).

Removing Water from the Fuel Tank

After prolonged use, water and other impurities accumulate in the bottom of the tank. Occasionally inspect the fuel tank for water contamination and drain the contents if required.

During cold weather, the more empty volume inside the tank, the easier it is for water to condense. This can be reduced by keeping the tank full with diesel fuel.

Cleaning Inside the Fuel Tank

If necessary, drain the fuel inside the fuel tank completely. Using a spray washer (Figure 63) wash out any deposits or debris that have accumulated inside the fuel tank.

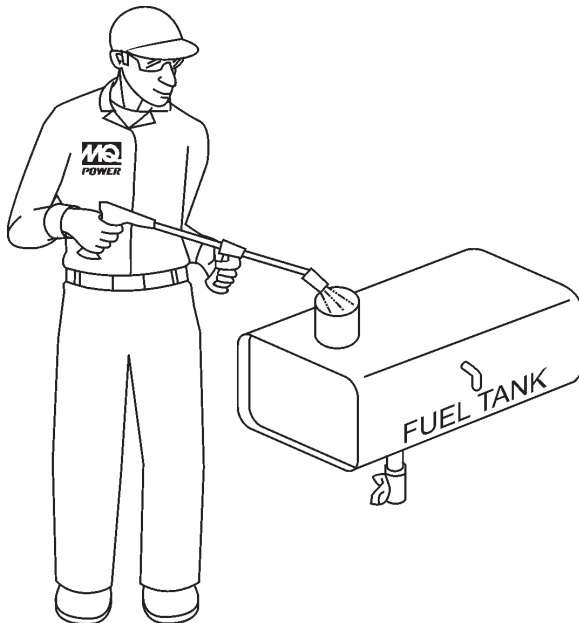

Figure 63. Fuel Tank Cleaning

FUEL TANK INSPECTION

In addition to cleaning the fuel tank, the following components should be inspected for wear:

- **Rubber Suspension** — look for signs of wear or deformity due to contact with oil. Replace the rubber suspension if necessary.
- **Fuel Hoses** — inspect nylon and rubber hoses for signs of wear, deterioration and hardening.
- **Fuel Tank Lining** — inspect the fuel tank lining for signs of excessive amounts of oil or other foreign matter.

Replacing Fuel Filter

- Replace the fuel filter cartridge with new one every 500 hours or so.
- Loosen the drain plug at the lower top of the fuel filter. Drain the fuel in the fuel body together with the mixed water. **DO NOT** spill the fuel during disassembly.
- Vent any air

AIR REMOVAL

If air enters the fuel injection system of a diesel engine, starting becomes impossible. After running out of fuel, or after disassembling the fuel system, bleed the system according to the following procedure. See the **Komatsu Engine Manual** for details.

To restart after running out of fuel, turn the switch to the “ON” position for 1530 seconds. Try again, if needed.

CHECK OIL LEVEL

Check the crankcase oil level prior to each use, or when the fuel tank is filled. Insufficient oil may cause severe damage to the engine. Make sure the generator is level. The oil level must be between the two notches on the dipstick as shown in Figure 26.

Replacing Oil Filter

- Remove the old oil filter.
- Apply a film of oil to the gasket on the new oil filter.
- Install the new oil filter.
- After the oil cartridge has been replaced, the engine oil will drop slightly. Run the engine for a while and check for leaks before adding more oil if needed. Clean excessive oil from engine.

FLUSHING OUT RADIATOR AND REPLACING COOLANT

- Open both cocks located at the crankcase side and at the lower part of the radiator and drain coolant. Open the radiator cap while draining. Remove the overflow tank and drain.
- Check hoses for softening and kinks. Check clamps for signs of leakage.
- Tighten both cocks and replace the overflow tank.
- Replace with coolant as recommended by the engine manufacturer.
- Close radiator cap tightly.
- Flush the radiator by running clean tap water through radiator until signs of rust and dirt are removed. **DO NOT** clean radiator core with any objects, such as a screwdriver.

WARNING



Allow engine to **cool** when flushing out radiator. Flushing the radiator while hot could cause serious burns from water or steam.

RADIATOR CLEANING

The radiator (Figure 64) should be sprayed (cleaned) with a high pressure washer when excessive amounts of dirt and debris have accumulated on the cooling fins or tube. When using a high pressure washer, stand at least 5 feet (1.5 meters) away from the radiator to prevent damage to the fins and tube.

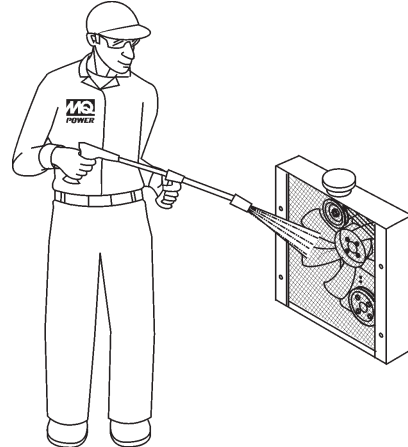

Figure 64. Radiator Cleaning

GENERATOR STORAGE

For long term storage of the generator the following is recommended:

- Drain the fuel tank completely. Treat with a fuel stabilizer if necessary.
- Completely drain the oil from the crankcase and refill if necessary with fresh oil.
- Clean the entire generator, internal and external.
- Cover the generating set and store in a clean, dry place.
- Disconnect the battery.
- Make sure engine coolant is at proper level.
- If generator is mounted on a trailer, jack trailer up and place on blocks so tires do not touch the ground or block and completely remove the tires.

JACKET WATER HEATER AND INTERNAL BATTERY CHARGER 120 VAC INPUT RECEPTACLES (OPTIONAL)

This generator can be optionally equipped with two 120 VAC, 20 amp input receptacles located on the output terminal panel.

The purpose of these receptacles is to provide power via commercial power to the **jacket water heater** and **internal battery charger**.

These receptacles will **ONLY** function when commercial power has been supplied to them (Figure 65). To apply commercial power to these receptacles, a power cord of adequate size will be required (See Table 6).

When using the generator in **hot** climates there is no reason to apply power to jacket water heater. However, if the generator will be used in **cold** climates it is always a good idea to apply power to the jacket water heater at all times. To apply power to the jacket water heater simply apply power to the jacket water heater receptacle via commercial power using an power cord of adequate size.

If the generator will be used daily, the battery should normally not require charging. If the generator will be idle (not used) for long periods of time, apply power to the battery charger receptacle via commercial power using a power cord of adequate size.

NOTICE

To ensure adequate starting capability, always have power applied to the generator's internal battery charger.

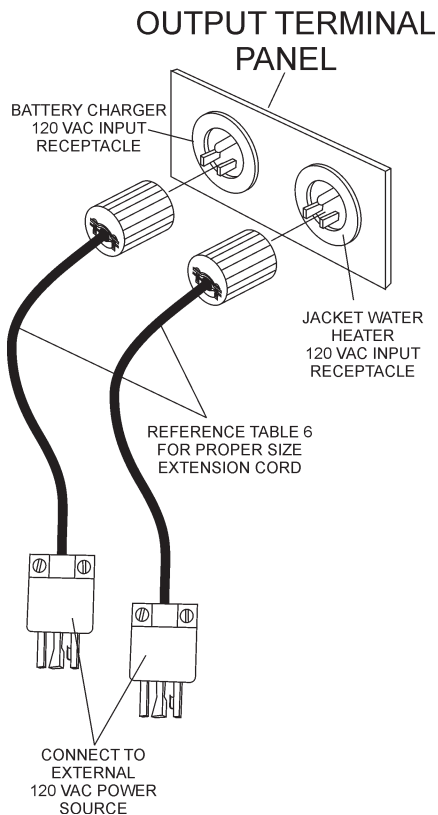

Figure 65. Battery Charger and Jacket Water Heater Power Connections

TRAILER MAINTENANCE

TRAILER MAINTENANCE

This section is intended to provide the user with generic trailer service and maintenance information. The service and maintenance guidelines referenced in this section refer to a wide range of trailers.

Remember periodic inspection of the trailer will ensure safe towing of the generator and will prevent personal injury and damage to the equipment.

The definitions below describe some of the major components of a typical trailer that would be used with generator.

1. **Fuel Cell** — Provides an adequate amount of fuel for the equipment in use. Fuel cells must be empty when transporting equipment.
2. **Braking System** — System employed in stopping the trailer. Typical braking systems are electric, surge, hydraulic, hydraulicsurge and air.
3. **GVWR** — Gross Vehicle Weight Rating (GVWR) is the maximum number of pounds the trailer can carry, including the fuel cell (empty).
4. **Frame Length** — Measurement is from the ball hitch to the rear bumper (reflector).
5. **Frame Width** — Measurement is from fender to fender
6. **Jack Stand** — Trailer support device with maximum pound requirement from the tongue of the trailer.
7. **Coupler** — Type of hitch used on the trailer for towing.
8. **Tire Size** — Indicates the diameter of the tire in inches (10,12,14, etc.), and the width in millimeters (175,185,205, etc.). The tire diameter must match the diameter of the tire rim.
9. **Tire Ply** — The tire ply (layers) number is rated in letters; 2ply,4ply,6ply, etc.
10. **Wheel Hub** — The wheel hub is connected to the trailer's axle.
11. **Tire Rim** — Tires mounted on a tire rim. The tire rim must match the size of the tire.
12. **Lug Nuts** — Used to secure the wheel to the wheel hub. Always use a torque wrench to tighten down the lug nuts. See Table 15 and Figure 68 for lug nut tightening and sequence.
13. **Axle** — Indicates the maximum weight the axle can support in pounds, and the diameter of the axle expressed in inches. Please note that some trailers have a double axle. This will be shown as 26000 lbs., meaning two axles with a total weight capacity of 6000 pounds.
14. **Suspension** — Protects the trailer chassis from shocks transmitted through the wheels. Types of suspension used are leaf, Qflex, and air ride.
15. **Electrical** — Electrical connectors (looms) are provided with the trailer so the brake lights and turn signals can be connected to the towing vehicle.
16. **Application** — Indicates which units can be employed on a particular trailer.

ELECTRIC BRAKES

Electrically actuated brakes (Figure 66) are similar to hydraulic brakes. The basic difference is that hydraulic brakes are actuated by an electromagnet. Listed below are some of the advantages that electric brakes have over hydraulic brakes:

- Brake system can be manually adjusted to provide the corrected braking capability for varying road and load conditions.
- Brake system can be modulated to provide more or less braking force, thus easing the brake load on the towing vehicle.
- Brake system has very little lag time between the time the vehicle's brakes are actuated and the trailer's brakes are actuated.
- Brake system can provide an independent emergency brake system.

Remember in order to properly synchronize the tow vehicle's braking to the trailer's braking, can only be accomplished by road testing. Brake lockup, grabbiness or harshness is due to lack of synchronization between the tow vehicle and the trailer being towed or underadjusted brakes.

Before any brake synchronizations adjustments can be made, the trailer brakes should be burnished in by applying the brakes 2030 times with approximately a 20 m.p.h. decrease in speed, e.g. 40 m.p.h. to 20 m.p.h. Allow ample time for brakes to cool between application. This allows the brake shoes to slightly be seated into the brake drum surface.

Figure 66. displays the major electric brake components that will require inspection and maintenance. Please inspect these components as required. See Table 13. Electric Brake Troubleshooting.

Magnets For All Electric Brakes

To make certain an electrically operated braking system will function properly, you must have your dealer inspect the magnets at least once a year, or each 12,000 miles. See the brake manual for wear and current inspection instructions.

Brake Controller

The electric brake controller is part of the tow vehicle and is essential in the operation of the electric brakes on the trailer. The brake controller is not the same as the safety breakaway brake system that may be equipped on the trailer.

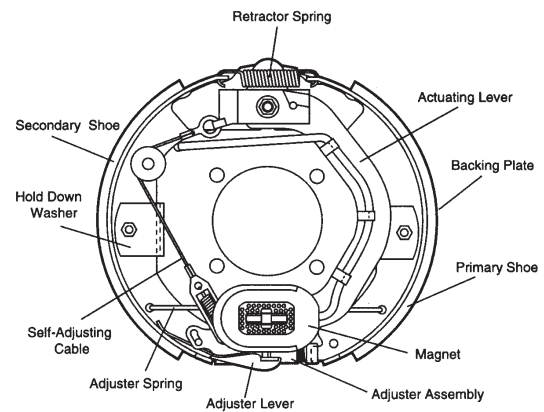

Figure 66. Hydraulic Brake Components
Brake Drums (or discs), Linings, and Hoses

Brake drums or discs must not have cracks longer than one half the width of the friction area. Linings must not be loose, soaked with oil or grease or be dangerously thin. Mechanical parts must be in place, not broken or missing. Check that all air hoses connected to the brake chambers are not worn or cut due to rubbing.

Air Leaks

Always check for brake air leaks before towing the trailer. **NEVER** tow the trailer with an brake air leak problem. The possibility exists of brake failure.

Table 13. Electric Brake Troubleshooting		
Symptom	Possible Cause	Solution
No Brakes or Intermittent Brakes	Any open circuits or broken wires?	Find and correct.
	Any short circuits?	Find and correct.
	Faulty controller?	Test and correct.
	Any loose connections?	Find and repair.
	Ground wire secure?	Find and secure.
Weak Brakes or Brakes Pull to One Side	Grease or oil on magnets or linings?	Clean or replace.
	Connections corroded?	Clean and correct cause of corrosion.
	Brake drums scored or grooved?	Machine or replace.
	Brakes synchronized?	Correct.
Locking Brakes	Brake components loose, bent or broken?	Replace components.
	Brake drums out of round?	Replace.
Noisy Brakes	System lubricated?	Lubricate.
	Brake components correct?	Replace and correct.
Dragging Brakes	Bearings of the wheel adjusted?	Adjust.

TRAILER MAINTENANCE

TIRES/WHEELS/LUG NUTS

Tires and wheels are a very important and critical components of the trailer. When specifying or replacing the trailer wheels it is important the wheels, tires, and axle are properly matched.

CAUTION



ALWAYS wear safety glasses when removing or installing force fitted parts. Failure to comply may result in serious injury.

CAUTION









DO NOT attempt to repair or modify a wheel. **DO NOT** install in inner tube to correct a leak through the rim. If the rim is cracked, the air pressure in the inner tube may cause pieces of the rim to explode (break off) with great force and cause serious eye or bodily injury.

Tire Wear/Inflation

Tire inflation pressure is the most important factor in tire life. Pressure should be checked cold before operation **DO NOT** bleed air from tires when they are **hot!** Check inflation pressure weekly during use to insure the maximum tire life and tread wear.

Table 14 (Tire Wear Troubleshooting) will help pinpoint the causes and solutions of tire wear problems.

Table 14. Tire Wear Troubleshooting			
Wear Pattern		Cause	Solution
	Center Wear	Over inflation.	Adjust pressure to particular load per tire manufacturer.
	Edge Wear	Under inflation.	Adjust pressure to particular load per tire manufacturer.
	Side Wear	Loss of camber or overloading.	Make sure load does not exceed axle rating. Align wheels.
	Toe Wear	Incorrect toein.	Align wheels.
	Cupping	Outofbalance.	Check bearing adjustment and balance tires.
	Flat Spots	Wheel lockup and tire skidding.	Avoid sudden stops when possible and adjust brakes.

Suspension

The Torsion axle systems, the suspension takes place inside the square tube which is filled with highly resilient rubber. It attaches directly to the trailer frame using brackets which are an integral part of the axle assembly (See Figure 67 below).

Visually inspect the mounting hardware every 6,000 miles for signs of excessive wear, elongation of bolt holes, and loosening of fasteners. Replace all damaged parts immediately. Torque torsion axle mounting hardware as recommended by manufacturer.

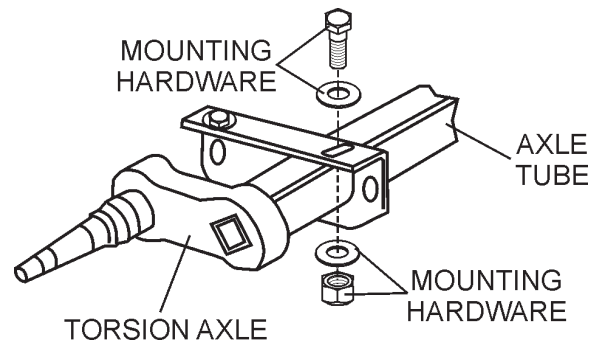

Figure 67. Major Suspension Components

TRAILER MAINTENANCE

Lug Nut Torque Requirements

It is extremely important to apply and maintain proper wheel mounting torque on the trailer. Be sure to use only the fasteners matched to the cone angle of the wheel. Proper procedure for attachment of the wheels is as follows:

1. Start all wheel lug nuts by hand.
2. Torque all lug nuts in sequence (see Figure 68). **DO NOT** torque the wheel lug nuts all the way down. Tighten each lug nut in 3 separate passes as defined by Table 15.
3. After first road use, retorque all lug nuts in sequence. Check all wheel lug nuts periodically.

Table 15. Tire Torque Requirements			
Wheel Size	First Pass FTLBS	Second Pass FTLBS	Third Pass FTLBS
12"	2025	3540	5065
13"	2025	3540	5065
14"	2025	5060	90120
15"	2025	5060	90120
16"	2025	5060	90120

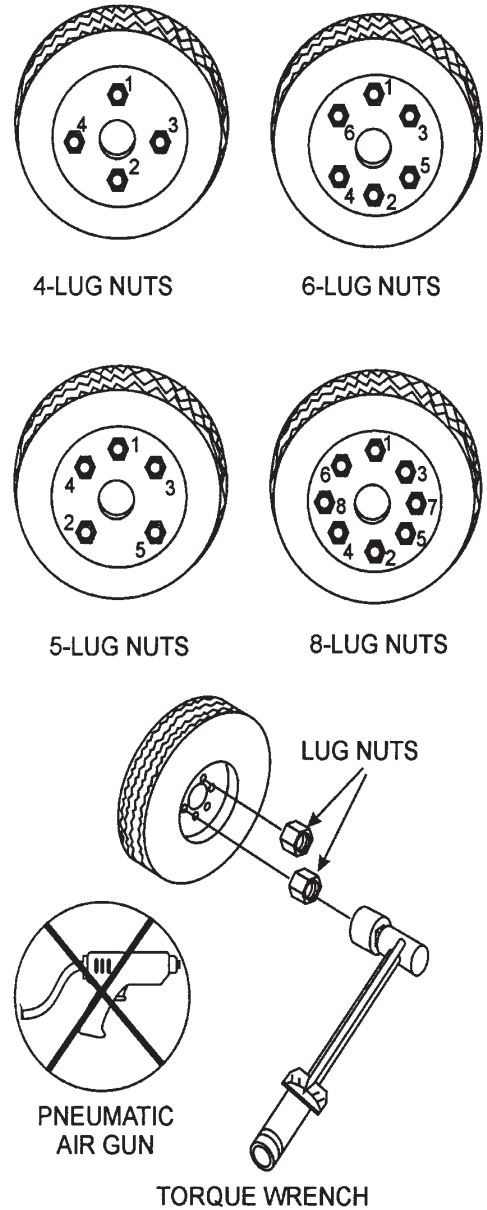

Figure 68. Wheel Lug Nuts Tightening Sequence

NOTICE

NEVER use an pneumatic air gun to tighten wheel lug nuts.

TRAILER WIRING DIAGRAM

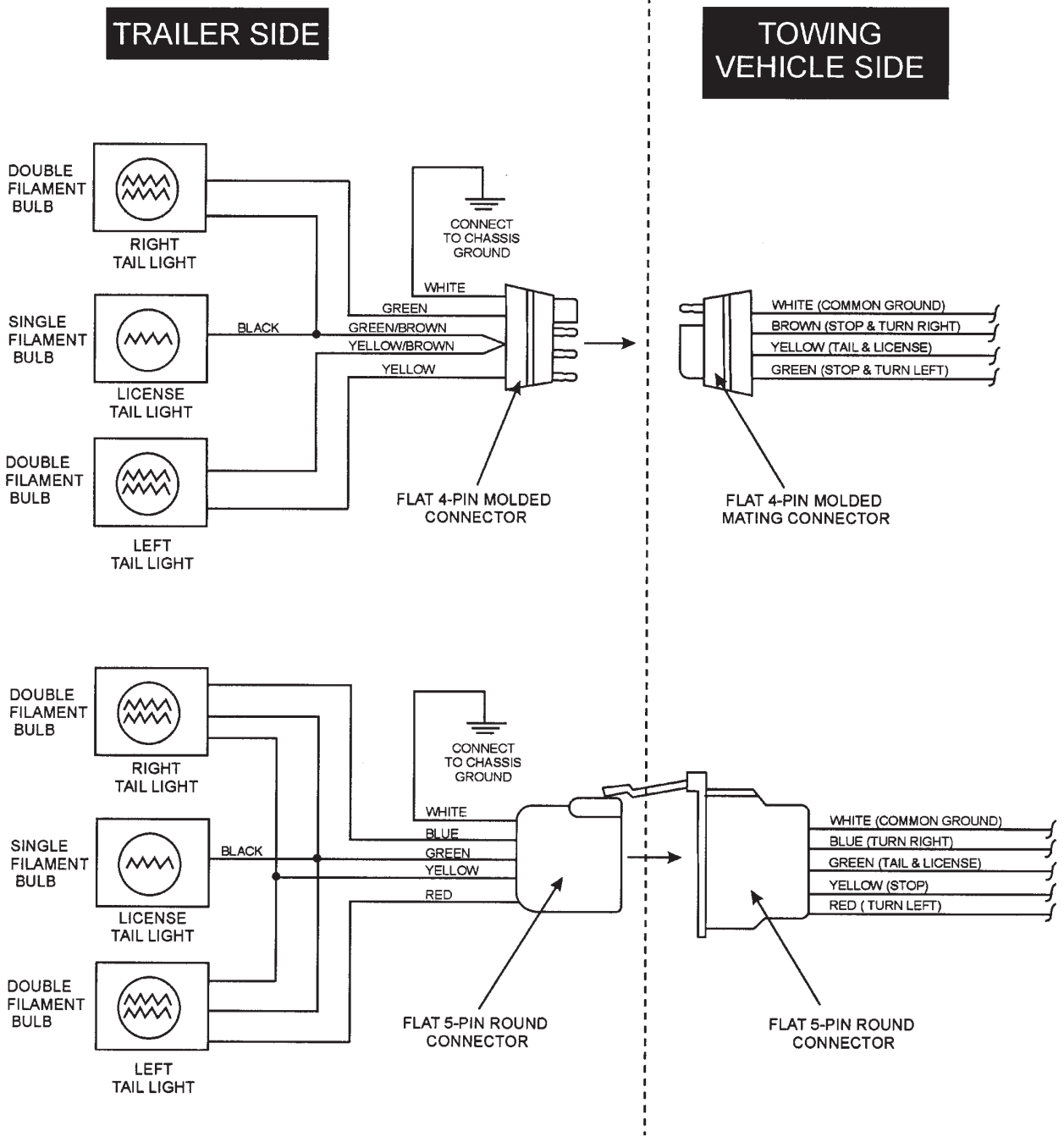

Figure 69. Trailer/Towing Vehicle Wiring Diagram

GENERATOR WIRING DIAGRAM

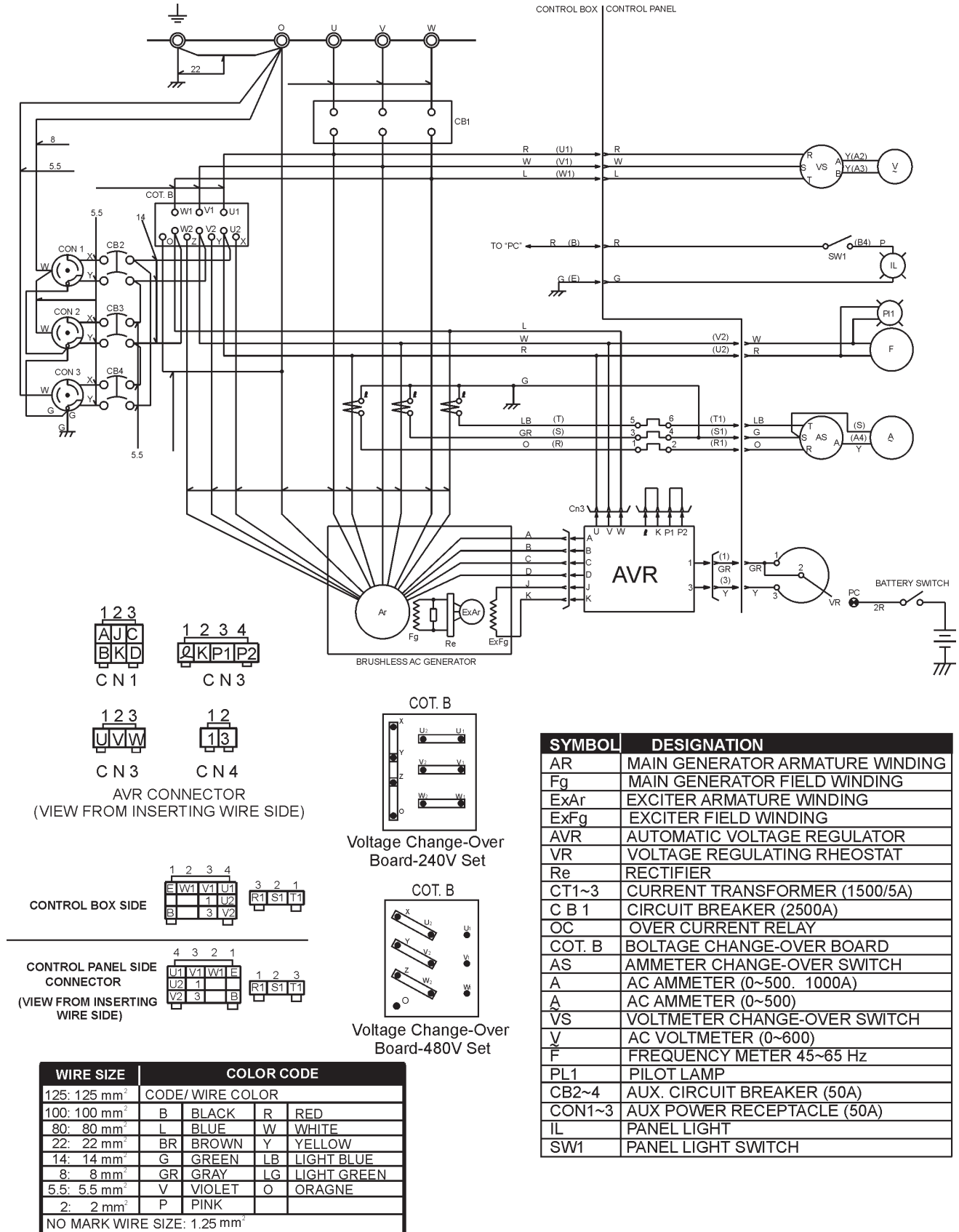
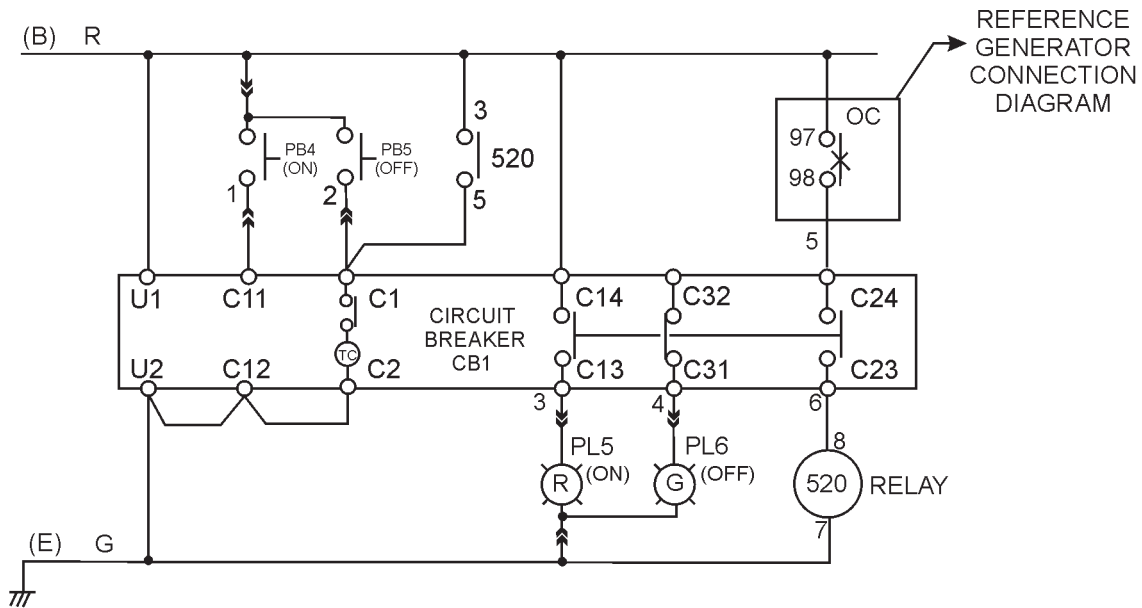

Figure 70. Generator Wiring Diagram

GENERATOR WIRING DIAGRAM (MAIN BREAKER)



WIRE SIZE	COLOR CODE			
	CODE/ WIRE COLOR			
125: 125 mm ²	B	BLACK	R	RED
100: 100 mm ²	L	BLUE	W	WHITE
80: 80 mm ²	BR	BROWN	Y	YELLOW
22: 22 mm ²	G	GREEN	LB	LIGHT BLUE
14: 14 mm ²	GR	GRAY	LG	LIGHT GREEN
8: 8 mm ²	V	VIOLET	O	ORANGE
5.5: 5.5 mm ²	P	PINK		
NO MARK WIRE SIZE: 1.25 mm ²				

SYMBOL	DESIGNATION
PB4	CIRCUIT BREAKER (ON) SWITCH
PB5	CIRCUIT BREAKER (OFF) SWITCH
PL5	CIRCUIT BREAKER (ON) LAMP
PL6	CIRCUIT BREAKER (OFF) LAMP

Figure 71. Engine Wiring Diagram

ENGINE WIRING DIAGRAM

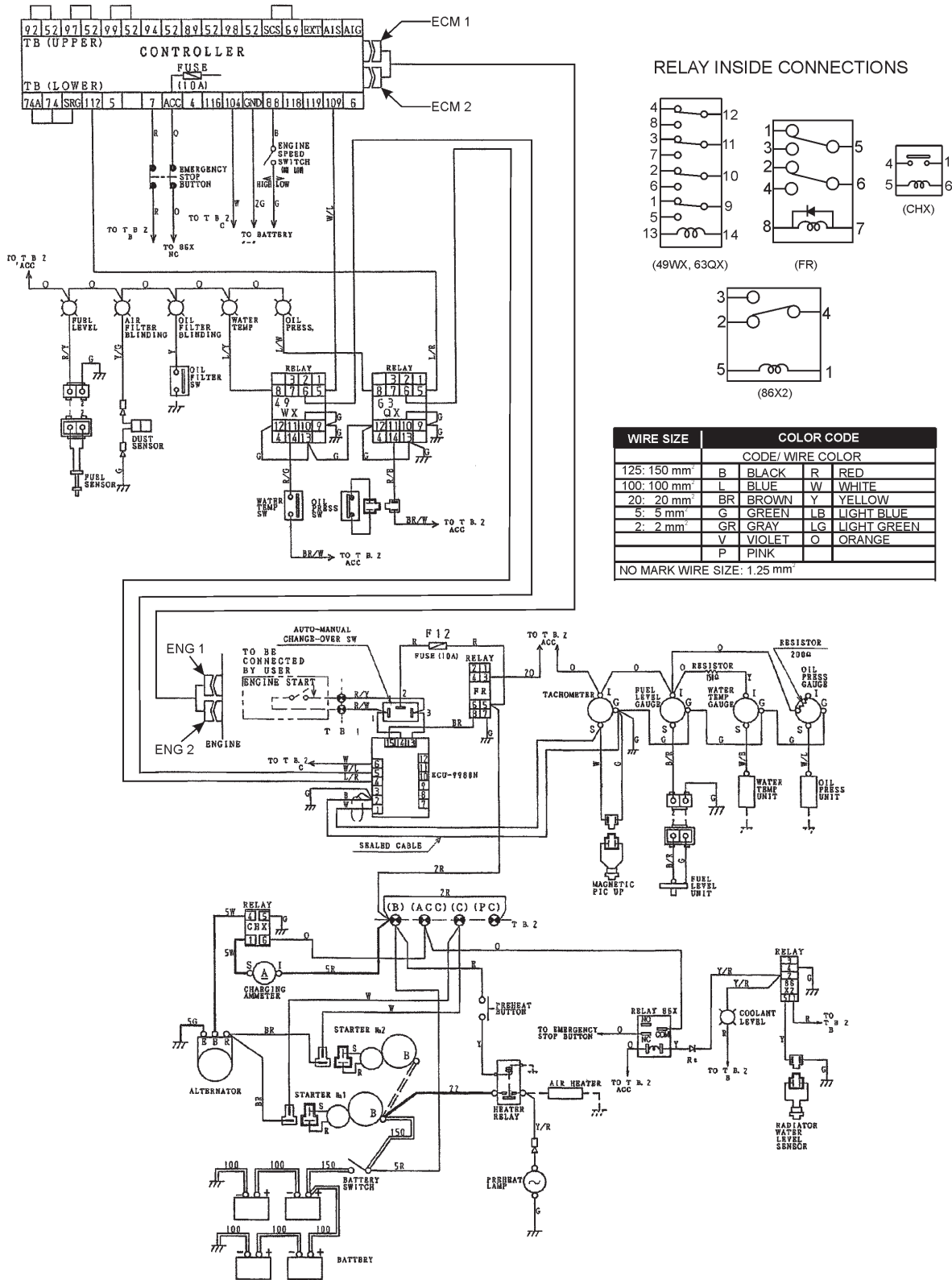

Figure 72. Controller Wiring Diagram

TROUBLESHOOTING (GENERATOR)

Practically all breakdowns can be prevented by proper handling and maintenance inspections, but in the event of a breakdown, use Table 16 shown below for diagnosis of the Generator. If the problem cannot be remedied, consult our company's business office or service plant.

Table 16. Generator Troubleshooting		
Symptom	Possible Problem	Solution
No Voltage Output	AC Voltmeter defective?	Check output voltage using a voltmeter.
	Is wiring connection loose?	Check wiring and repair.
	Is AVR defective?	Replace if necessary.
	Defective Rotating Rectifier?	Check and replace.
	Defective Exciter Field?	Check for approximately 17.3 ohms across J & K on CN1
Low Voltage Output	Is engine speed correct?	Turn engine throttle lever to "High".
	Is wiring connections loose?	Check wiring and repair.
	Defective AVR?	Replace if necessary.
High Voltage Output	Is wiring connections loose?	Check wiring and repair.
	Defective AVR?	Replace if necessary.
Circuit Breaker Tripped	Short Circuit in load?	Check load and repair.
	Over current?	Confirm load requirements and reduce.
	Defective circuit breaker?	Check and replace.
	Over current Relay actuated?	Confirm load requirement and replace.

TROUBLESHOOTING (ENGINE CONTROLLER)

Practically all breakdowns can be prevented by proper handling and maintenance inspections, but in the event of a breakdown, use Table 17 (Engine Controller Troubleshooting) as a basic guideline for troubleshooting the Microprocessor Engine Controller unit (MPEC). If the problem cannot be remedied, consult our company's business office or service plant.

Table 17. Engine Controller Troubleshooting (MPEC)		
Symptom	Possible Problem	Solution
Low oil pressure light is on.	Low oil level?	Fill oil level.
	Oil pressure sending unit failure?	Replace oil pressure sending unit.
	Time delay malfunction in controller?	Refer to dealer.
	Wire shorted?	Inspect/repair wire.
Low coolant level light is on. (Optionally installed)	Low coolant level?	Fill coolant level.
	Sending unit failure?	Replace sending unit.
	Low battery voltage?	Replace/charge battery.
High coolant temperature light is on.	Fan belt tension incorrect?	Tighten/replace fan belt.
	Air flow is not circulating through radiator?	Clean/repair radiator grill.
	Doors open?	Close doors.
	Exhaust leaking?	Replace/repair gaskets or faulty part.
	Generator being overloaded?	Check/reduce load.
	Thermostat failure?	Replace thermostat.
	Air intake blocked?	Clean all air intakes.
Overcrank light is on.	Temperature switch failure	Replace temperature switch.
	No or low fuel?	Fill fuel level.
Overspeed light is on.	Controller needs to be calibrated?	Refer to dealer.
	RPM engine speed too high?	Adjust RPM.
	Governor actuator needs to be adjusted?	Adjust governor actuator.
	Governor controller needs to be adjusted?	Adjust governor controller.
Loss of MPU light(s) or on.	Engine controller needs to be calibrated?	Refer to dealer.
	Magnetic pick up out of adjustment?	Adjust magnetic pick up.
	Magnetic pick up dirty?	Clean magnetic pick up.

TROUBLESHOOTING (ENGINE CONTROLLER)

This generator is equipped with an electronic governor for unit injection system. The engine controller (Figure 73), consists of a display, switches, trimmer, etc., for monitoring and for controlling the engine.

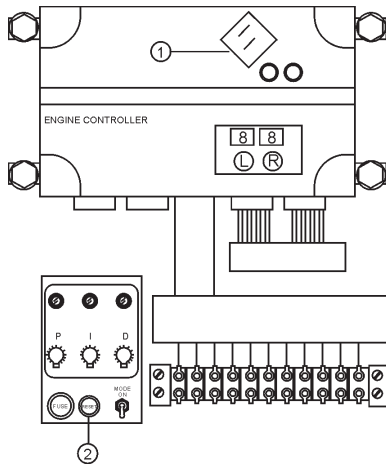

Figure 73. Komatsu Engine Controller

The definitions below describe the controls and functions of the Engine Controller (Figure 73).

1. **Display** — Displays engine malfunctions. When the engine starts and the controller turns ON, various engine parameters will be checked within about 10 seconds. If the engine system is normal and working correctly the display will show "00".

If the engine controller detects an engine malfunction (parameter abnormality) an "E" will be displayed followed by the error code and the type of failure.

NOTICE

For a complete understanding of error codes and troubleshooting procedures, refer to the enclosed engine instruction manual.

2. **Reset Button** — To clear the display after a fault or abnormal parameter has occurred, press and hold this button for one second. This will reset the display.

EXPLANATION OF CODE IN REMARKS COLUMN

The following section explains the different symbols and remarks used in the Parts section of this manual. Use the help numbers found on the back page of the manual if there are any questions.

NOTICE

The contents and part numbers listed in the parts section are subject to change **without notice**. Multiquip does not guarantee the availability of the parts listed.

SAMPLE PARTS LIST

NO.	PART NO.	PART NAME	QTY.	REMARKS
1	12345	BOLT.....	1	INCLUDES ITEMS W/%
2%		WASHER, 1/4 IN.....		NOT SOLD SEPARATELY
2%	12347	WASHER, 3/8 IN....	1	MQ-45T ONLY
3	12348	HOSE	A/R	MAKE LOCALLY
4	12349	BEARING	1	S/N 2345B AND ABOVE

NO. Column

Unique Symbols — All items with same unique symbol

(@, #, +, %, or >) in the number column belong to the same assembly or kit, which is indicated by a note in the “Remarks” column.

Duplicate Item Numbers — Duplicate numbers indicate multiple part numbers, which are in effect for the same general item, such as different size saw blade guards in use or a part that has been updated on newer versions of the same machine.

NOTICE

When ordering a part that has more than one item number listed, check the remarks column for help in determining the proper part to order.

PART NO. Column

Numbers Used — Part numbers can be indicated by a number, a blank entry, or TBD.

TBD (To Be Determined) is generally used to show a part that has not been assigned a formal part number at the time of publication.

A blank entry generally indicates that the item is not sold separately or is not sold by Multiquip. Other entries will be clarified in the “Remarks” Column.

QTY. Column

Numbers Used — Item quantity can be indicated by a number, a blank entry, or A/R.

A/R (As Required) is generally used for hoses or other parts that are sold in bulk and cut to length.

A blank entry generally indicates that the item is not sold separately. Other entries will be clarified in the “Remarks” Column.

REMARKS Column

Some of the most common notes found in the “Remarks” Column are listed below. Other additional notes needed to describe the item can also be shown.

Assembly/Kit — All items on the parts list with the same unique symbol will be included when this item is purchased.

Indicated by:
 “INCLUDES ITEMS W/(unique symbol)”

Serial Number Break — Used to list an effective serial number range where a particular part is used.

Indicated by:
 “S/N XXXXX AND BELOW”
 “S/N XXXX AND ABOVE”
 “S/N XXXX TO S/N XXX”

Specific Model Number Use — Indicates that the part is used only with the specific model number or model number variant listed. It can also be used to show a part is NOT used on a specific model or model number variant.

Indicated by:
 “XXXXX ONLY”
 “NOT USED ON XXXX”

“Make/Obtain Locally” — Indicates that the part can be purchased at any hardware shop or made out of available items. Examples include battery cables, shims, and certain washers and nuts.

“Not Sold Separately” — Indicates that an item cannot be purchased as a separate item and is either part of an assembly/kit that can be purchased, or is not available for sale through Multiquip.

SUGGESTED SPARE PARTS

DCA800SSK2 WHISPERWATT GENERATOR WITH KOMATSU SAA6D170E3 DIESEL ENGINE

1 to 3 units

<u>QTY.</u>	<u>P/N</u>	<u>DESCRIPTION</u>
12.....	0602046653.....	AIR FILTER, ELEMENT, OUTER
6.....	0602046653-1	AIR FILTER, ELEMENT, INNER
12.....	6003193320.....	FUEL FILTER, ENGINE
24.....	6002111231.....	CARTRIDGE OIL FILTER
6.....	6004111171.....	CARTRIDGE, CORROSION RESISTOR
6.....	0810105400.....	FUEL FILTER, FUEL TANK
2.....	6240613821.....	FAN BELT, ENGINE
2.....	6240816180.....	ALTERNATOR BELT, ENGINE
4.....	6162144810.....	RADIATOR HOSE (UPPER)
1.....	6240611950.....	RADIATOR HOSE (UPPER-INNER)
1.....	6162639651.....	RADIATOR HOSE (LOWER)
1.....	1140348160.....	CAP, RADIATOR
1.....	0601820625.....	AUTOMATIC VOLTAGE REGULATOR
3.....	0601808804.....	CIRCUIT BREAKER, 50 AMP
1.....	0601840073.....	RHEOSTAT, (VOLTAGE REGULATOR)
2.....	0601840100.....	KNOB, RHEOSTAT
1.....	0601810072.....	PILOT LAMP
2.....	0601810261.....	BULB, PILOT LAMP
1.....	0602122272.....	UNIT, OIL PRESSURE, FOR GAUGE
1.....	0602123267.....	UNIT, WATER TEMPERATURE, FOR GAUGE
1.....	0601810261.....	CIRCUIT BREAKER BULB, ON/OFF LAMP
1.....	0601802149.....	FUSE, 10 AMP
1.....	6008158280.....	SWITCH, OIL PRESSURE
1.....	6216849140.....	SENSOR ASSY., COOLANT TEMPERATURE

NOTICE

Part number on this Suggested Spare Parts list may supersede/replace the P/N shown in the text pages of this book.

GENERATOR ASSY.

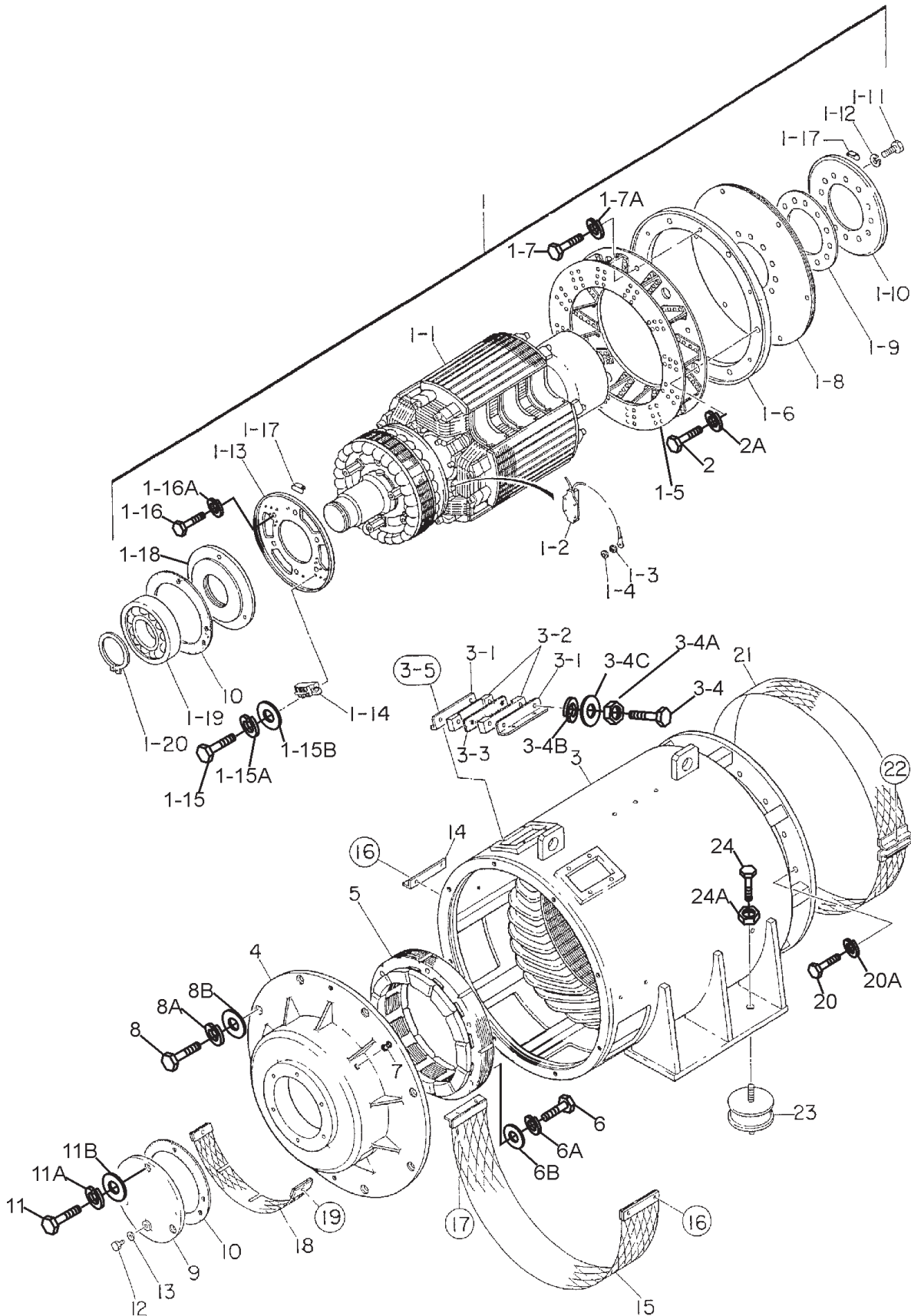

GENERATOR ASSY.

<u>NO.</u>	<u>PART NO.</u>	<u>PART NAME</u>	<u>QTY.</u>	<u>REMARKS</u>
1	C5110000402	ROTOR ASSY.....	1.....	INCLUDES ITEM W/#
1-1#		FIELD ASSY.	1	
1-2#	0601842366	RESISTOR, 80W 50K Ω	4	
1-3#	8171020004	INSULATOR WASHER	6	
1-4#	8171020504	INSULATOR WASHER	6	
1-5#	C5111100002	FAN	1	
1-6#	C5163400003	COUPLING RING	1	
1-7#	0010312025	HEX HEAD BOLT	2	
1-7A#	0042512000	WASHER, LOCK	2	
1-8#	C5163100104	COUPLING DISK ASSY.	1	
1-9#	C5163200004	COUPLING HUB WASHER	1	
1-10#	C5111300003	BALANCING PLATE.....	1.....	PURCHASE ITEM 1-17 AS A SET
1-11#	0012724060	HEX HEAD BOLT	10	
1-12#	0042524000	WASHER, LOCK	10	
1-13#	8461026023	RECTIFIER SET PLATE.....	1.....	PURCHASE ITEM1-17 AS A SET
1-14#	0601823282	RECTIFIER	2	
1-15#	0018205020	HEX SOCKET HEAD CAP SCREW	4	
1-15A#	0040005000	WASHER, LOCK	4	
1-15B#	0041205000	WASHER, FLAT	4	
1-16#	0010112020	HEX HEAD BOLT	6	
1-16A#	0040012000	WASHER, LOCK	6	
1-17#	0601000209	BALANCING WEIGHT KIT	1	
1-18	C5111500003	BEARING FLANGE	1	
1-19	0072906322	BEARING	1	
1-20	0080000110	SNAP RING	1	
1-21#	C5153300104	BEARING GASKET	1	
2	0012116065	HEX HEAD BOLT	10	
2A	0042516000	WASHER, LOCK	10	
3	C5130000003	STARTER ASSY.	1	
31	C5131200404	CLAMPER	4	
32	C5131200014	CLAMPER	4	
33	C5131200504	CLAMPER	2	
34	0016310090	HEX HEAD BOLT	4	
34A	0030010000	HEX NUT	4	
34B	0040010000	WASHER, LOCK	8	
34C	0041210000	WASHER, FLAT	4	
35	0017110020	HEX HEAD BOLT	8	
4	C5153000002	END BRACKET	1	
5	C4137000003	EXCITER FIELD ASSY	1	
6	0012110075	HEX HEAD BOLT	6	
6A	0042610000	WASHER, LOCK	6	
6B	0041210000	WASHER, FLAT	6	
7	0845044904	GROMMET	1	

GENERATOR ASSY. (CONTINUED)

<u>NO.</u>	<u>PART NO.</u>	<u>PART NAME</u>	<u>QTY.</u>	<u>REMARKS</u>
8	0016316045	HEX HEAD BOLT	8	
8A	0040016000	WASHER, LOCK	8	
8B	0041216000	WASHER, FLAT	8	
9	C5153300003	BEARING COVER	1	
10	C5153300104	BEARING GASKET	1	
11	0016308095	HEX HEAD BOLT	3	
11A	0040008000	WASHER, LOCK	3	
11B	0041208000	WASHER, FLAT	3	
12	0010110016	HEX HEAD BOLT	1	
13	0803000104	PACKING	1	
14	8461335004	COVER BRACKET	1	
15	C5131300103	STATOR COVER	1	
16	0017106012	HEX HEAD BOLT	4	
17	0017106050	HEX HEAD BOLT	2	
18	8461333003	EXCITER COVER	1	
19	0017106012	HEX HEAD BOLT	2	
20	0012112040	HEX HEAD BOLT	16	
20A	0042512000	WASHER, LOCK	16	
21	C5131300003	FAN COVER	1	
22	0017106050	HEX HEAD BOLT	1	
23	0605000012	RUBBER SUSPENSION	4	
24	0030020000	HEX NUT	8	
24A	0040020000	WASHER, LOCK	8	

CONTROL PANEL ASSY.

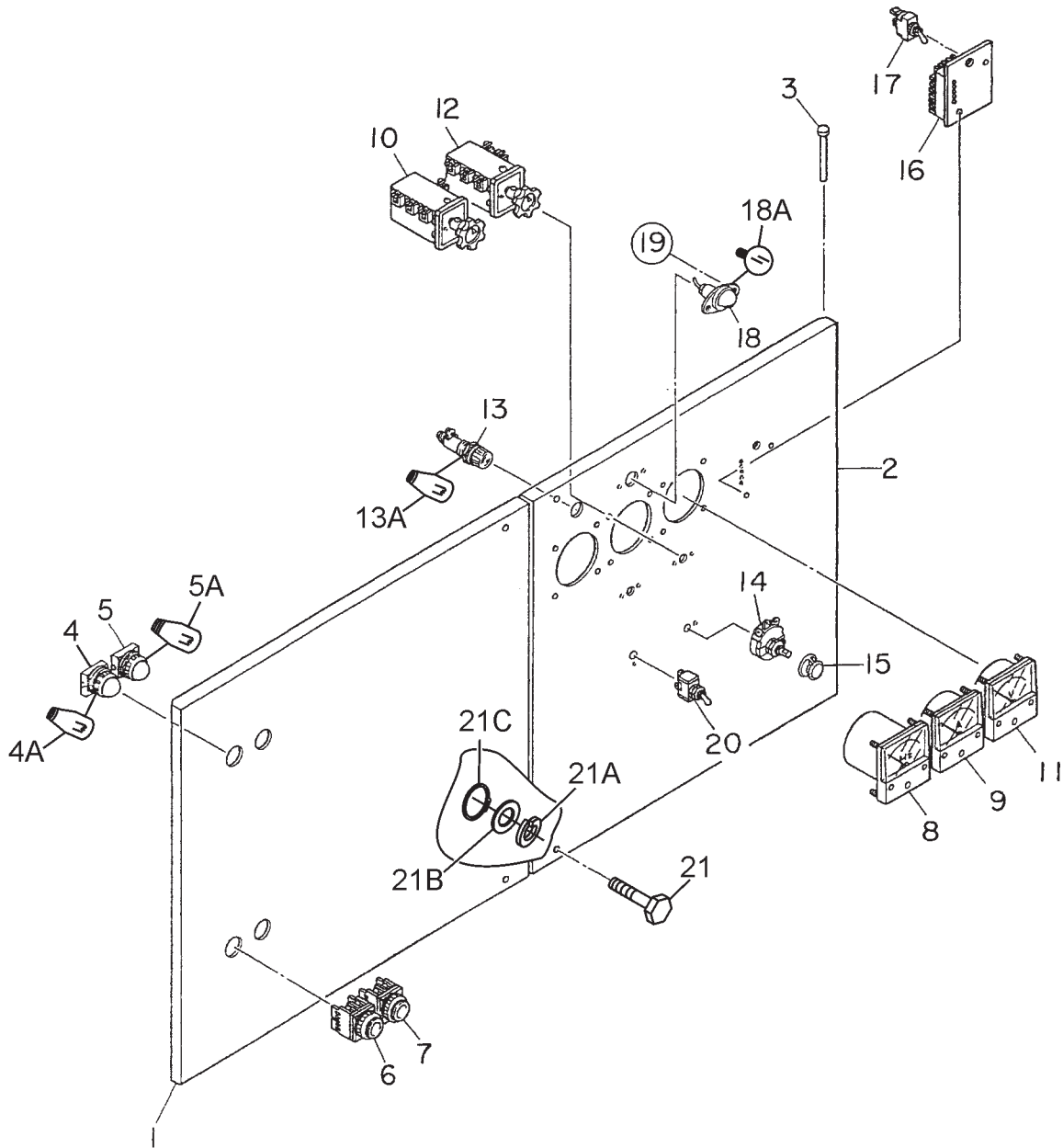

CONTROL PANEL ASSY.

<u>NO.</u>	<u>PART NO.</u>	<u>PART NAME</u>	<u>QTY.</u>	<u>REMARKS</u>
1	C5224002303	CONTROL PANEL	1	
2	C5224002103	CONTROL PANEL	1	
3	0605011211	PIN	4	
4	0601810476	CIRCUIT BREAKER OFF LAMP	1	
4A	0601810235	BULB	1	
5	0601810467	CIRCUIT BREAKER ON LAMP	1	
5A	0601810235	BULB	1	
6	0601830498	CIRCUIT BREAKER OFF SWITCH	1	
7	0601831224	CIRCUIT BREAKER ON SWITCH	1	
8	0601800480	FREQUENCY METER, 220V 45 ~ 65Hz	1	
9	0601800795	AC AMMETER, 0~1500A 0~3000A	1	
10	0601801040	AMMETER CHANGE OVER SWITCH	1	
11	0601800252	AC VOLTMETER, ~ 600V	1	
12	0601801041	VOLTMETER CHANGE OVER SWITCH	1	
13	0601810072	PILOT LAMP	1	
13A	0601810261	BULB	1	
14	0601840073	RHEOSTAT (VOLTAGE REGULATOR)	1	
15	0601840100	KNOB	1	
16	ECU99888N600/800	ENGINE CONTROLLER.....	1REPLACES P/N 0602202545
17	0601830765	SWITCH	1	
18	0601810161	PANEL LIGHT	1	
18A	0601810214	BULB	1	
19	0207004000	HEX NUT	2	
20	0601830710	PANEL LIGHT SWITCH	1\	
21	C9221100004	HEX. HEAD BOLT	4	
21A	0040008000	WASHER, LOCK	4	
21B	0041208000	WASHER, FLAT	4	
21C	0080200007	SNAP RING	4	

CONTROL BOX ASSY.

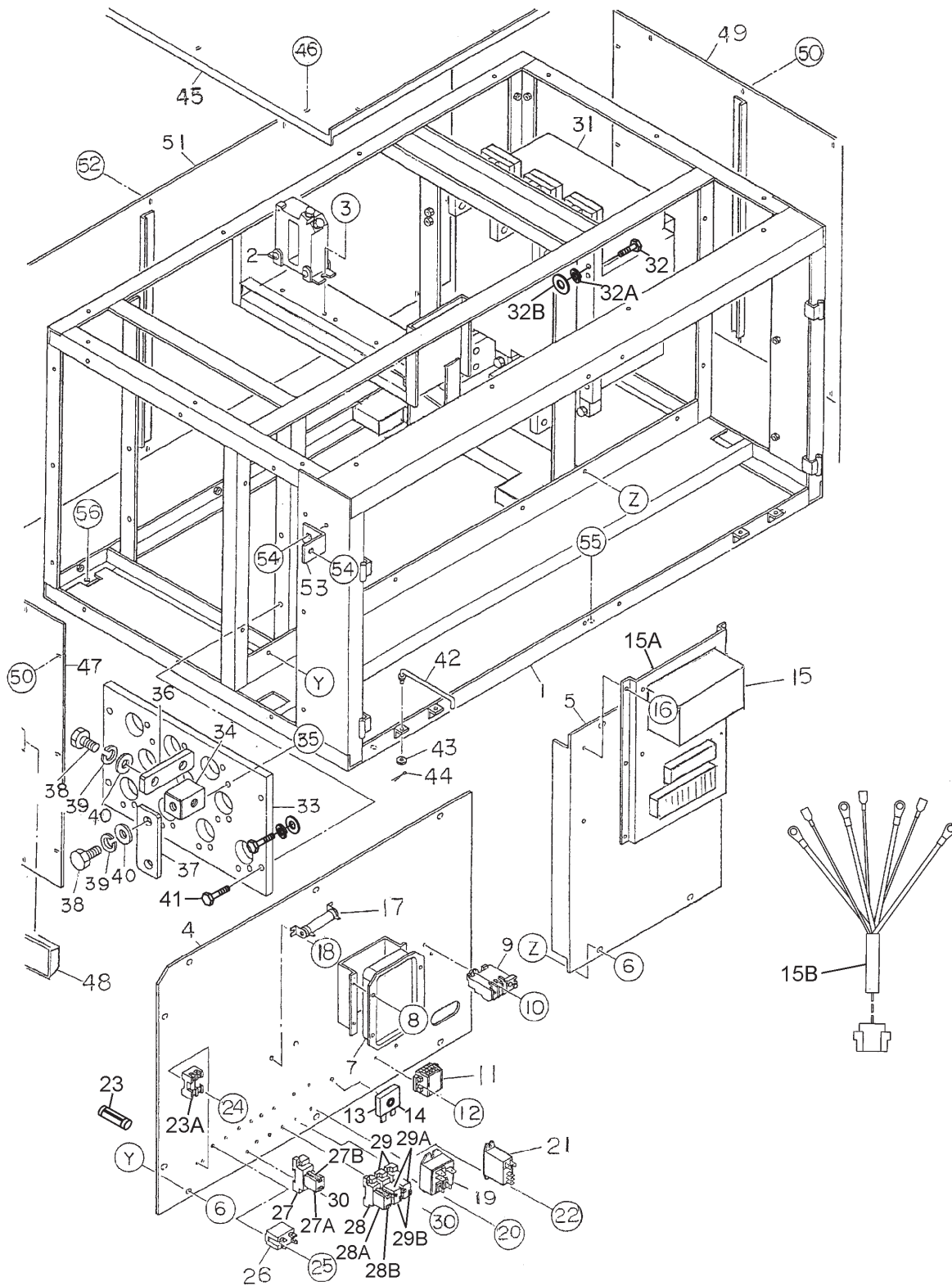

CONTROL BOX ASSY.

<u>NO.</u>	<u>PART NO.</u>	<u>PART NAME</u>	<u>QTY.</u>	<u>REMARKS</u>
1	C5214001602	CONTROL BOX	1	
2	0601806166	AMMETER CURRENT TRANSFORMER	3	
3	0017108020	HEX HEAD BOLT	6	
4	C5261503703	ELECTRIC PARTS SET PANEL	1	
5	C5261503503	ELECTRIC PARTS SET PANEL	1	
6	0017108020	HEX HEAD BOLT	14	
7	0601820625	AUTOMATIC VOLTAGE REGULATOR	1	
8	0027105016	MACHINE SCREW	4	
9	0601820892	OVER CURRENT RELAY	1	
10	0027104016	MACHINE SCREW	2	
11	0601815402	TERMINAL BOARD	1	
12	0027104020	MACHINE SCREW	2	
13	0601823240	RECTIFIER	1	
14	0027105020	MACHINE SCREW	1	
15	7818529500	CONTROLLER.....	1	REPLACES P/N 0602202615
15A	6240815300	PANEL.....	1	REPLACES P/N 0602129110
15B	6240815400	WIRE HARNESS.....	1	REPLACES P/N 0602202431
16	0017106015	HEX HEAD BOLT	6	
17	0601842468	RESISTOR, 5W 150 OHM	1	
18	0027103010	MACHINE SCREW	2	
19	0601828533	RELAY, DC24V	1	
20	0027104016	MACHINE SCREW	2	
21	0601826022	RELAY, DC24V	1	
22	0027103010	MACHINE SCREW	2	
23	0601802149	FUSE, 10A	1	
23A	0601802211	FUSE HOLDER	1	
24	0027504020	MACHINE SCREW	2	
25	0601823706	RELAY, DC24V	1	
26	0027104016	MACHINE SCREW	2	
27	LY2DC24V	RELAY.....	1	REPLACES P/N 0601823732
27A	PTF08A	SOCKET.....	1	REPLACES P/N 0601823109
27B	PYCA1	HOLDER	1	REPLACES P/N 0601824400
28	LY2DDC24V	RELAY.....	1	REPLACES P/N 0601827655
28A	PTF08A	SOCKET.....	1	REPLACES P/N 0601823109
28B	PYCA1	HOLDER.....	1	REPLACES P/N 0601824400
29	0601823759	RELAY	2	
29A	PYF14A	SOCKET.....	2	REPLACES P/N 0601823146
29B	PYCA1	HOLDER.....	2	REPLACES P/N 0601824000
30	0027104016	MACHINE SCREW	8	
31	M7080041000Q	CIRCUIT BREAKER, S8V 2500A.....	1	REPLACES P/N C5244300003
32	0010308050	HEX HEAD BOLT	8	
32A	0042508000	WASHER, LOCK	8	
32B	0041208000	WASHER, FLAT	8	
33	7521861303	VOLTAGE CHANGEOVER BOARD	1	

CONTROL BOX ASSY. (CONTINUED)

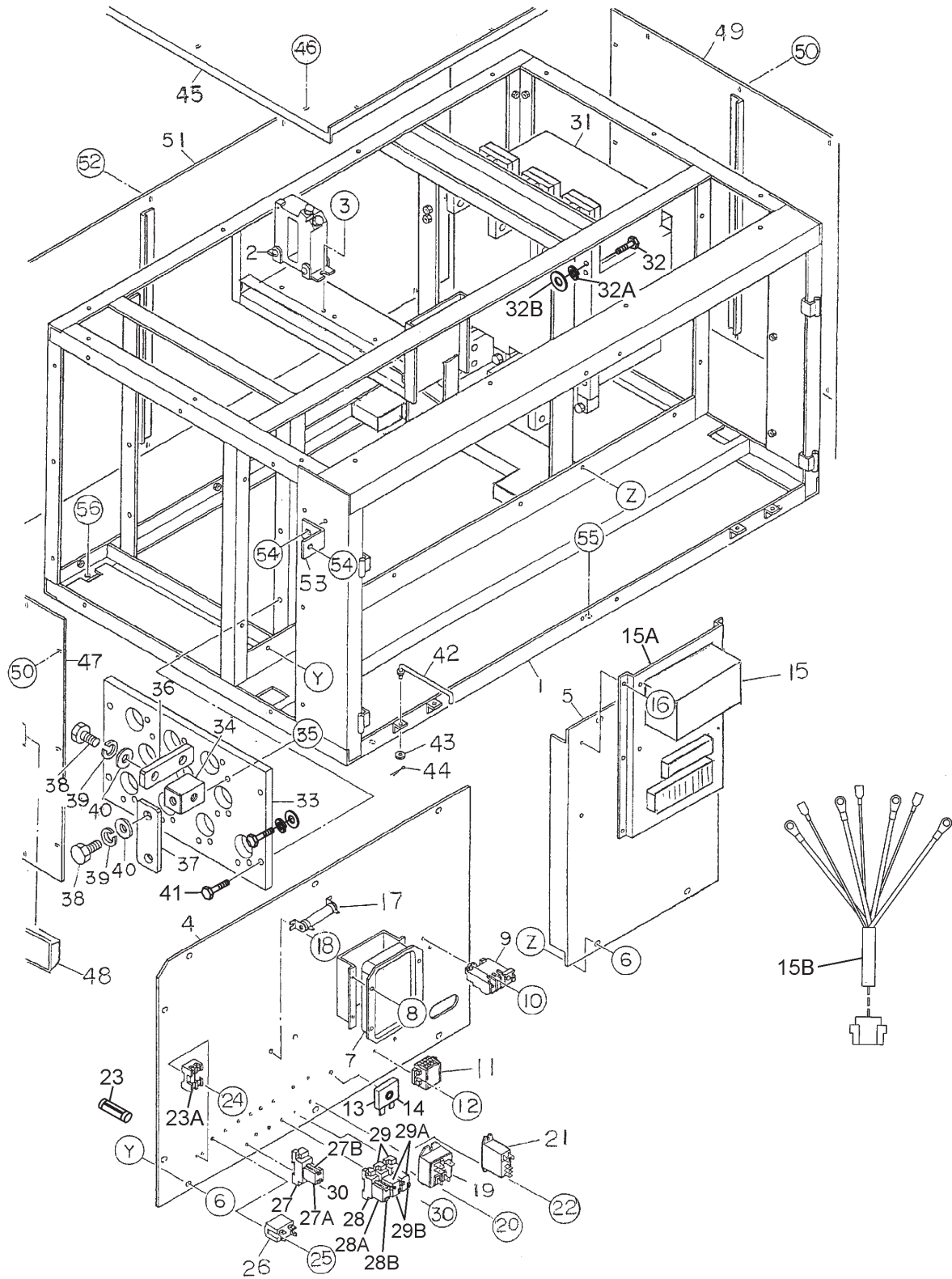

CONTROL BOX ASSY. (CONTINUED)

<u>NO.</u>	<u>PART NO.</u>	<u>PART NAME</u>	<u>QTY.</u>	<u>REMARKS</u>
34	C5277200004	CHANGE TERMINAL	10	
35	0017108035	HEX HEAD BOLT	20	
36	C5277200004	TERMINAL PLATE	10	
37	C5277300004	CHANGE PLATE	6	
38	0801832504	HEX HEAD BOLT	20	
39	0040020000	WASHER, LOCK	20	
40	0041420000	WASHER, FLAT	20	
41	0010110040	HEX HEAD BOLT	4	
41A	0040010000	WASHER, LOCK	4	
41B	0041210000	WASHER, FLAT	4	
42	3871824004	CONTROL PANEL STOPPER	2	
43	0041206000	WASHER, FLAT	2	
44	0605010502	SNAP PIN	2	
45	C5214500303	CONTROL BOX COVER	1	
46	0017106016	HEX HEAD BOLT	14	
47	C5214300304	CONTROL BOX SIDE PANEL	1	
48	0601850349	EMBEDDED PULLS	1	
49	C5214300404	CONTROL BOX SIDE PANEL	1	
50	0017106016	HEX HEAD BOLT	24	
51	C5214400203	CONTROL BOX PANEL	1	
52	0017106016	HEX HEAD BOLT	15	
53	7521811904	BRACKET	2	
54	0017110025	HEX HEAD BOLT	4	
55	0017108020	HEX HEAD BOLT	3	
56	0017110030	HEX HEAD BOLT	4	
56A	0207010000	HEX NUT	4	

ENGINE ASSY.

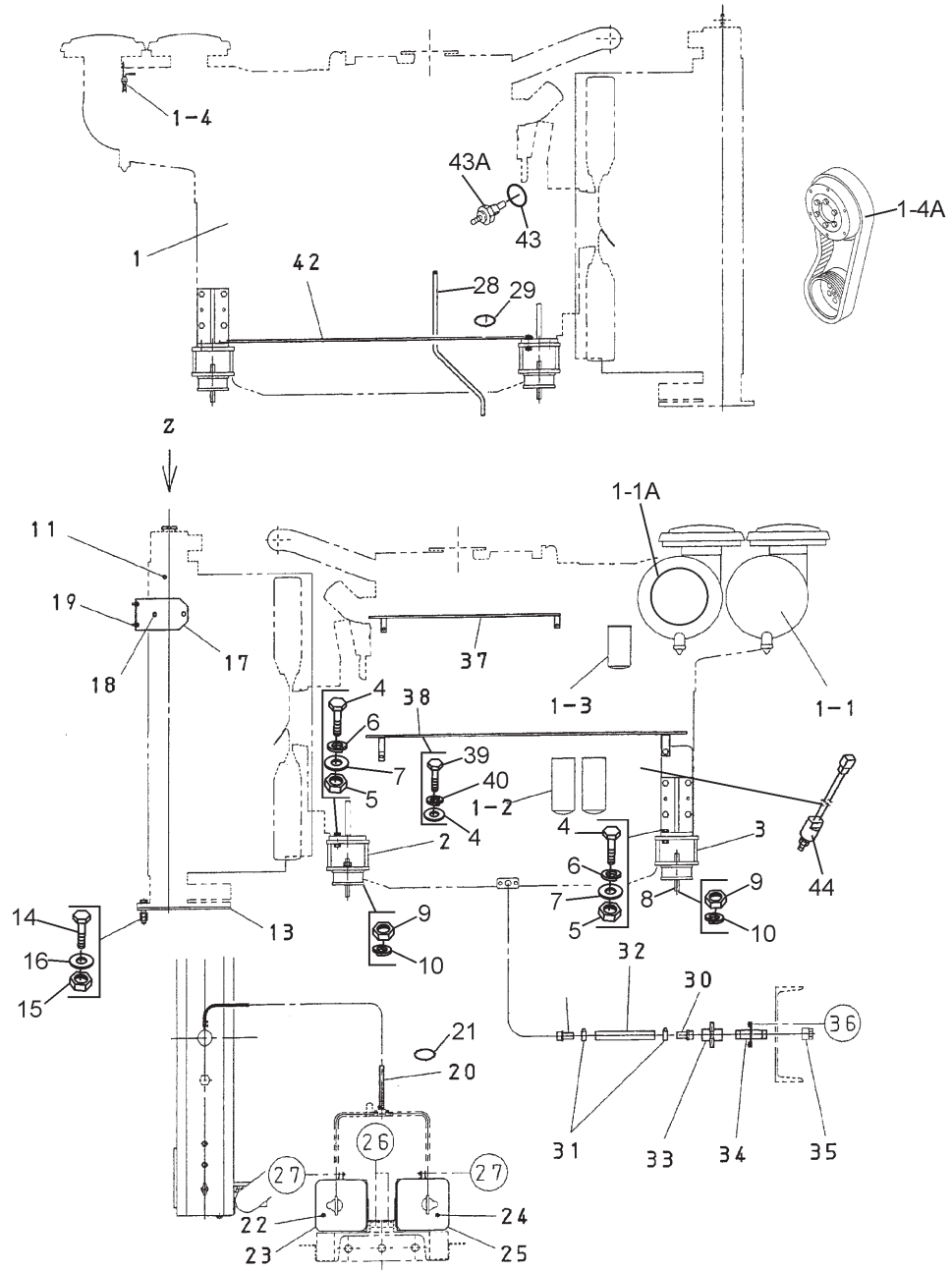

ENGINE ASSY.

<u>NO.</u>	<u>PART NO.</u>	<u>PART NAME</u>	<u>QTY.</u>	<u>REMARKS</u>
1	C5924200134	ENGINE, KOMATSU SAA170E3	1	
1-1	0602046653	AIR CLEANER ELEMENT OUTER	2	
1-1A	0602046653-1	AIR CLEANER ELEMENT, INNER	2	
1-2	6002111231	OIL FILTER CARTRIDGE	2	REPLACES P/N 0602041146
1-3	6004111171	CORROSION RESISTOR CARTRIDGE	1	REPLACES P/N 0602045144
1-4	6008711220	DUST SENSOR	1	REPLACES P/N 060204043
1-4A	6240613821	FAN BELT	1	REPLACES P/N 0602015227
2	C5304200504	ENGINE FOOT	2	
3	C5304200604	ENGINE FOOT	2	
4	0010118070	HEX HEAD BOLT	8	
5	0030018000	HEX NUT	8	
6	0040018000	WASHER, LOCK	8	
7	0041618000	WASHER, FLAT	8	
8	0605000012	RUBBER SUSPENSION	4	
9	0030020000	HEX NUT	8	
10	0040020000	WASHER, LOCK	8	
13	6995619380	CUSHION.....	2	REPLACES P/N 0605000498
14	0010118100	HEX HEAD BOLT	8	
15	0030018000	HEX NUT	16	
16	0041618000	WASHER, FLAT	16	
17	C5311100104	RADIATOR BRACKET	2	
18	0017112025	HEX HEAD BOLT	4	
19	0017110025	HEX HEAD BOLT	4	
20	0199603100	HOSE	1	
21	0605515170	HOSE CLIP	1	
22	6162637810	RESERVE TANK	1	REPLACES P/N 0602010207
23	C2317100503	RESERVE TANK BRACKET	1	
24	6212617210	RESERVE TANK	1	REPLACES P/N 0602010206
25	C5317100003	RESERVE TANK BRACKET	1	

ENGINE ASSY. (CONTINUED)

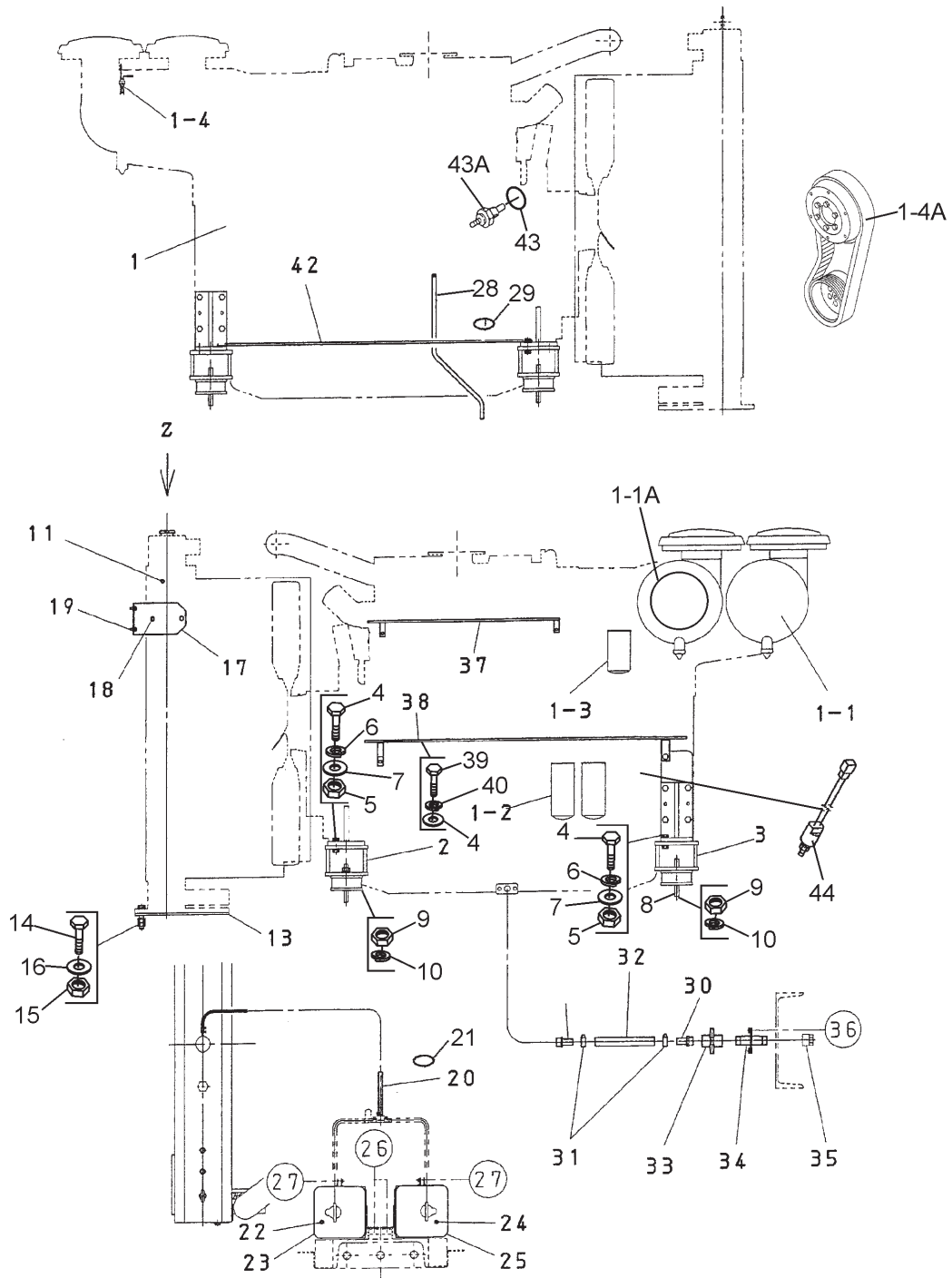

ENGINE ASSY. (CONTINUED)

<u>NO.</u>	<u>PART NO.</u>	<u>PART NAME</u>	<u>QTY.</u>	<u>REMARKS</u>
26	0017108020	HEX HEAD BOLT	4	
27	0017106030	HEX HEAD BOLT	2	
28	0194200840	HOSE	1	
29	0605515019	HOSE BAND	1	
30	0602022294	HOSE JOINT	2	
31	0605515074	HOSE BAND		
32	0265800560	HOSE	1	
33	0603325017	VALVE	1	
34	C0321200004	DRAIN JOINT	1	
35	C0321300004	CAP	1	
36	0019208025	HEX HEAD BOLT	2	
37	C5322600304	CLAMPER ROD	1	
38	C5358300904	CLAMPER ROD	1	
39	0010118030	HEX HEAD BOLT	1	
40	0040018000	WASHER, LOCK	1	
41	0041618000	WASHER, FLAT	1	
42	C5358300804	CLAMPER ROD	1	
43	6216849140	SENSOR ASSY., COOLANT TEMP.....	1S/N 316346 AND ABOVE
43A	6735211930	O-RING	1	
44	6008158280	SWITCH, OIL PRESSURE.....	1S/N 316346 AND ABOVE

RADIATOR ASSY. (S/N 316346 AND ABOVE)

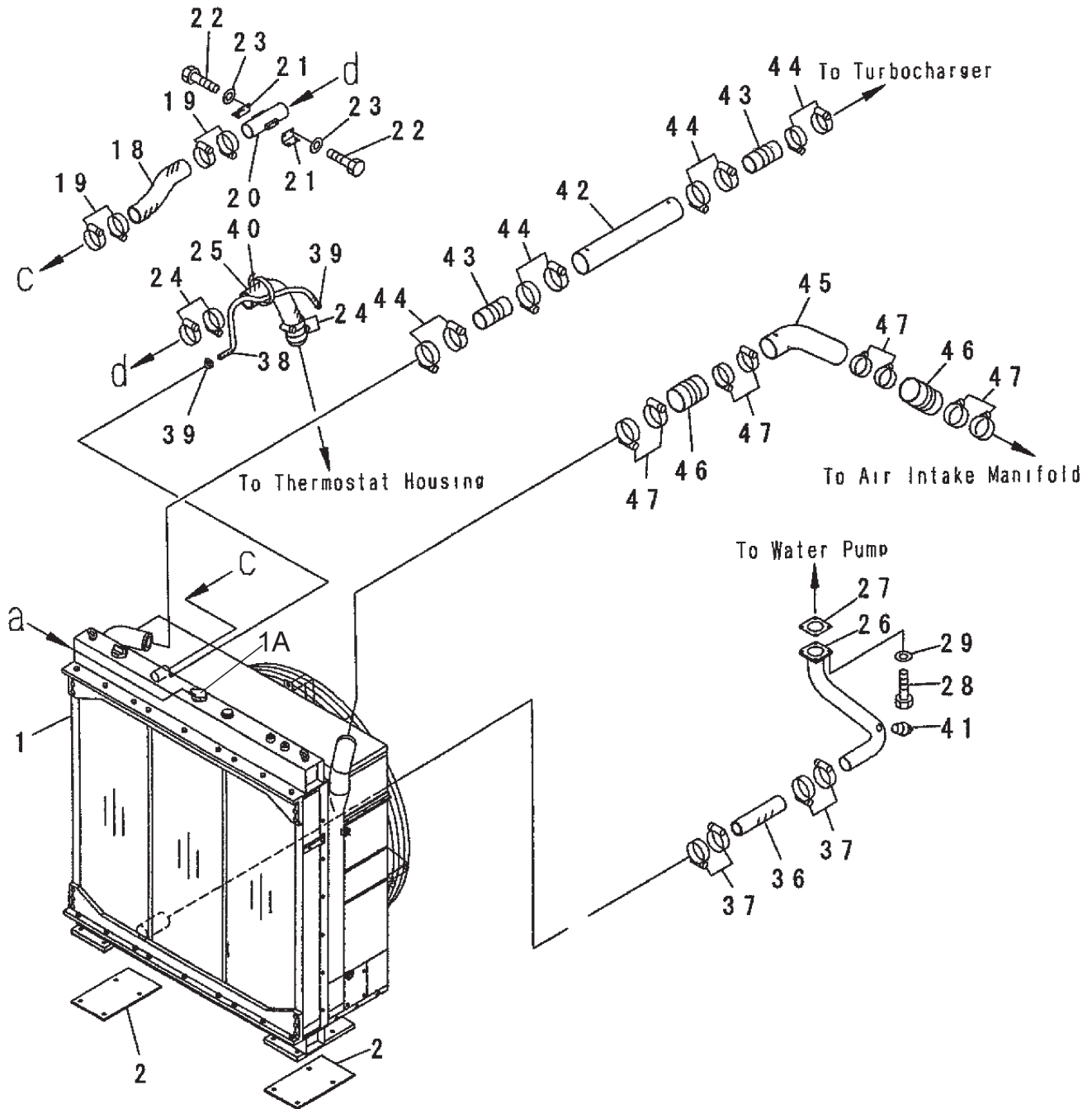

RADIATOR ASSY. (S/N 316346 AND ABOVE)

<u>NO.</u>	<u>PART NO.</u>	<u>PART NAME</u>	<u>QTY.</u>	<u>REMARKS</u>
1	6240619300	RADIATOR ASSY.	1	REPLACES P/N 0602012734
1A	1140348160	RADIATOR CAP	1	REPLACES P/N 0602011021
2	6995619380	CUSHION	2	
18	6240611950	HOSE, RADIATOR, UPPER, INNER	1	
19	0728101029	CLAMP	4	
20	6240612010	TUBE	1	
21	6240612020	BRACKET	2	
22	0101081020	BOLT	8	
23	0164331032	WASHER	8	
24	0728101029	CLAMP	4	
25	6240611960	HOSE	1	
26	6240612080	CONNECTOR	1	
27	6693629242	GASKET	1	
28	0101081025	BOLT	4	
29	0164331032	WASHER	4	
36	6162639651	HOSE, RADIATOR, LOWER	1	
37	0728101029	CLAMP	4	
38	0726120913	HOSE	1	
39	0728100197	CLAMP	2	
40	0803400536	BAND	2	
41	0704200617	PLUG	1	
42	6240112550	TUBE	1	
43	6162144810	HOSE	2	
44	0729900120	CLAMP	8	
45	6240112560	TUBE	1	
46	6162144810	HOSE	2	
47	0728900120	CLAMP	8	

ALTERNATOR ASSY. (S/N 311209 AND ABOVE)

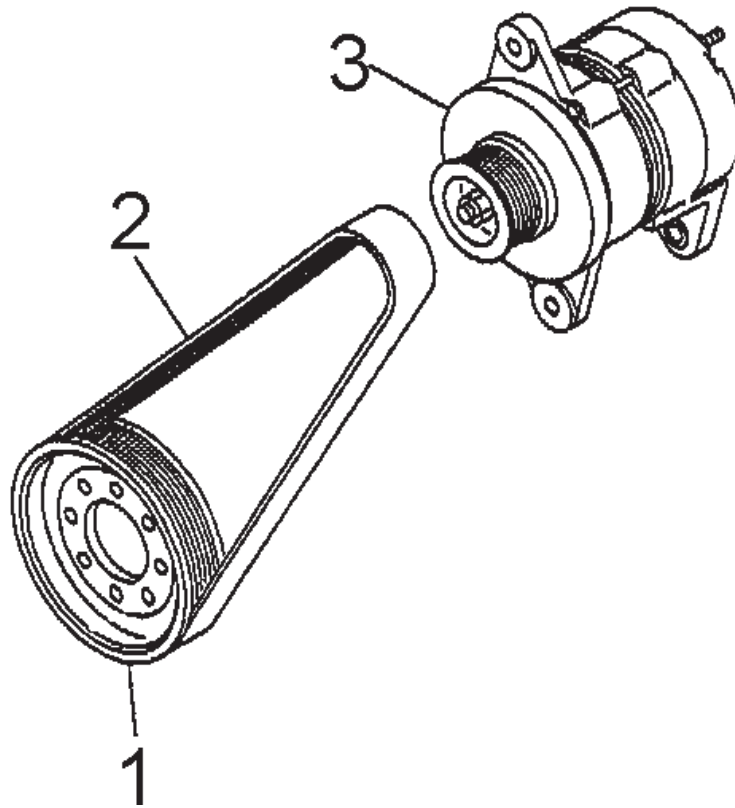

ALTERNATOR ASSY. (S/N 311209 AND ABOVE)

<u>NO.</u>	<u>PART NO.</u>	<u>PART NAME</u>	<u>QTY.</u>	<u>REMARKS</u>
1	6240816150	PULLEY, NON HARDENING	1	
2	6240816180	BELT, ALTERNATOR	1	
3	6008253161	ALTERNATOR, ASSY	1	

THEROMOSTAT ASSY. (S/N 316346 AND ABOVE)

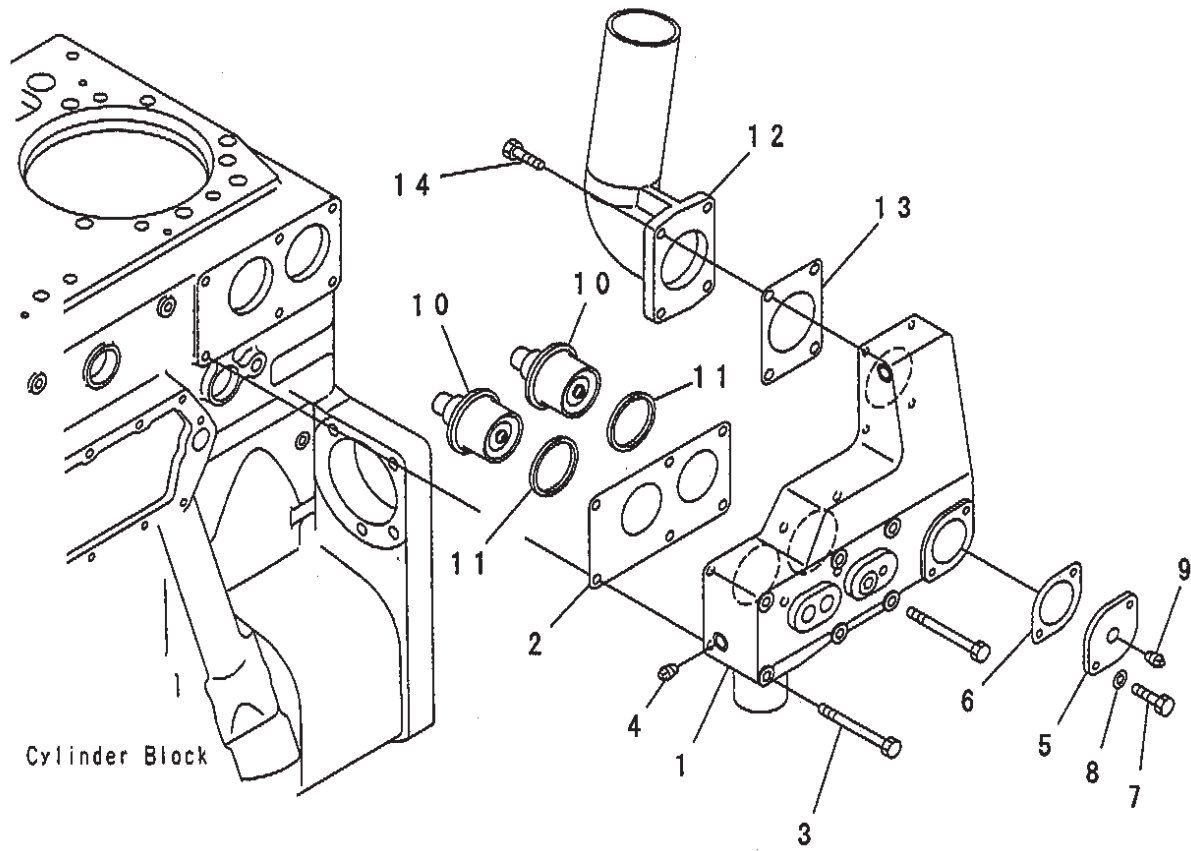

THERMOSTAT ASSY. (S/N 316346 AND ABOVE)

<u>NO.</u>	<u>PART NO.</u>	<u>PART NAME</u>	<u>QTY.</u>	<u>REMARKS</u>
1	6240116410	HOUSING, THERMOSTAT	1	
2	6240116470	GASKET	1	
3	0101081095	BOLT	5	
4	0704230108	PLUG	2	
5	6240116480	PLATE	1	
6	6222116820	GASKET	1	
7	0101081035	BOLT	2	
8	0164331032	WASHER	2	
9	0704200415	PLUG	1	
10	6004216630	THERMOSTAT	2	
11	6162136440	SEAL, THERMOSTAT	?	
12	6240611761	TUBE	1	
13	6162136481	GASKET	1	
14	0101081030	BOLT	4	

WATER PUMP ASSY.

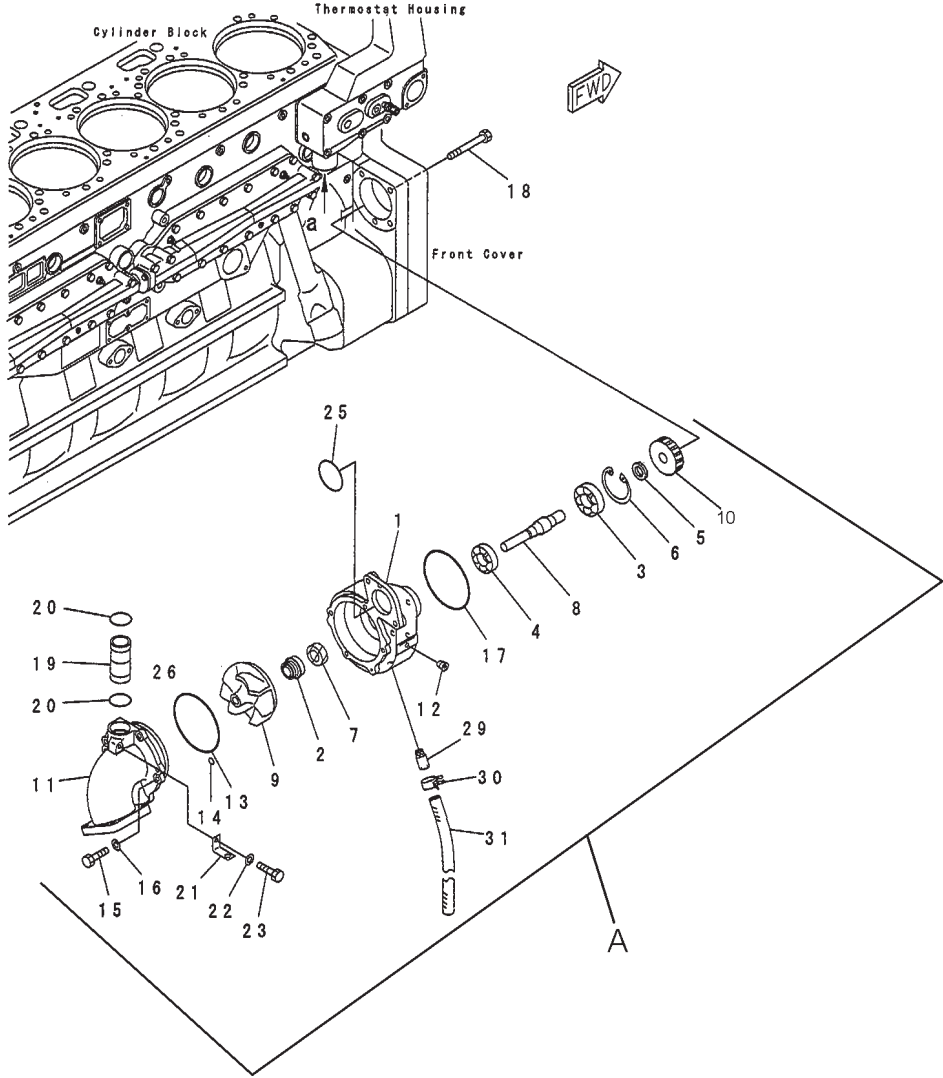

WATER PUMP ASSY.

<u>NO.</u>	<u>PART NO.</u>	<u>PART NAME</u>	<u>QTY.</u>	<u>REMARKS</u>
A	6240611302	WATER PUMP ASSY.....	1.....	S/N 315602 AND ABOVE INCLUDES ITEMS W/\$
1\$		BODY	1.....	S/N 315602 AND ABOVE
2\$	6162631515	SEAL, WATER.....	1.....	S/N 311819 AND ABOVE
3\$	0634006305	BEARING, BALL	1.....	S/N 310007 AND ABOVE
4\$	0603006205	BEARING, BALL	1.....	S/N 310007 AND ABOVE
5\$	6240611470	SPACER	1.....	S/N 310007 AND ABOVE
6\$	6240611440	RING	1.....	S/N 310007 AND ABOVE
7\$	07012D0022	SEAL, OIL	1.....	S/N 310007 AND ABOVE
8\$	6240611321	SHAFT.....	1.....	S/N 311819 AND ABOVE
9\$	6240611210	IMPELLER.....	1.....	S/N 310007 AND ABOVE
10\$	6240611410	GEAR	1.....	S/N 310007 AND ABOVE
11\$	6240611150	COVER.....	1.....	S/N 310007 AND ABOVE
12\$	0704370211	PLUG.....	1.....	S/N 310007 AND ABOVE
13\$	07000G2140	O-RING	1.....	S/N 310007 AND ABOVE
14\$	07000G2012	O-RING	1.....	S/N 310007 AND ABOVE
15\$	0101081030	BOLT	4.....	S/N 310007 AND ABOVE
16\$	0164331032	WASHER.....	4.....	S/N 310007 AND ABOVE
17	0700072095	O-RING	1.....	S/N 310007 AND ABOVE
18	0101181215	BOLT	4.....	S/N 310007 AND ABOVE
19	6240611560	TUBE.....	1.....	S/N 310007 AND ABOVE
20	07000A3039	O-RING	2.....	S/N 310007 AND ABOVE
21	6150215720	BRACKET	1.....	S/N 310007 AND ABOVE
22	0101080812	BOLT	1.....	S/N 310007 AND ABOVE
23	0164020816	WASHER.....	1.....	S/N 310007 AND ABOVE
25	07000G2075	O-RING	1.....	S/N 310007 AND ABOVE
29	6162631270	NIPPLE.....	1.....	S/N 310007 AND ABOVE
30	0728500180	CLIP	1.....	S/N 310007 AND ABOVE
31	0728701410	HOSE	1.....	S/N 310007 AND ABOVE

STARTER ASSY. (S/N 316346 AND ABOVE)

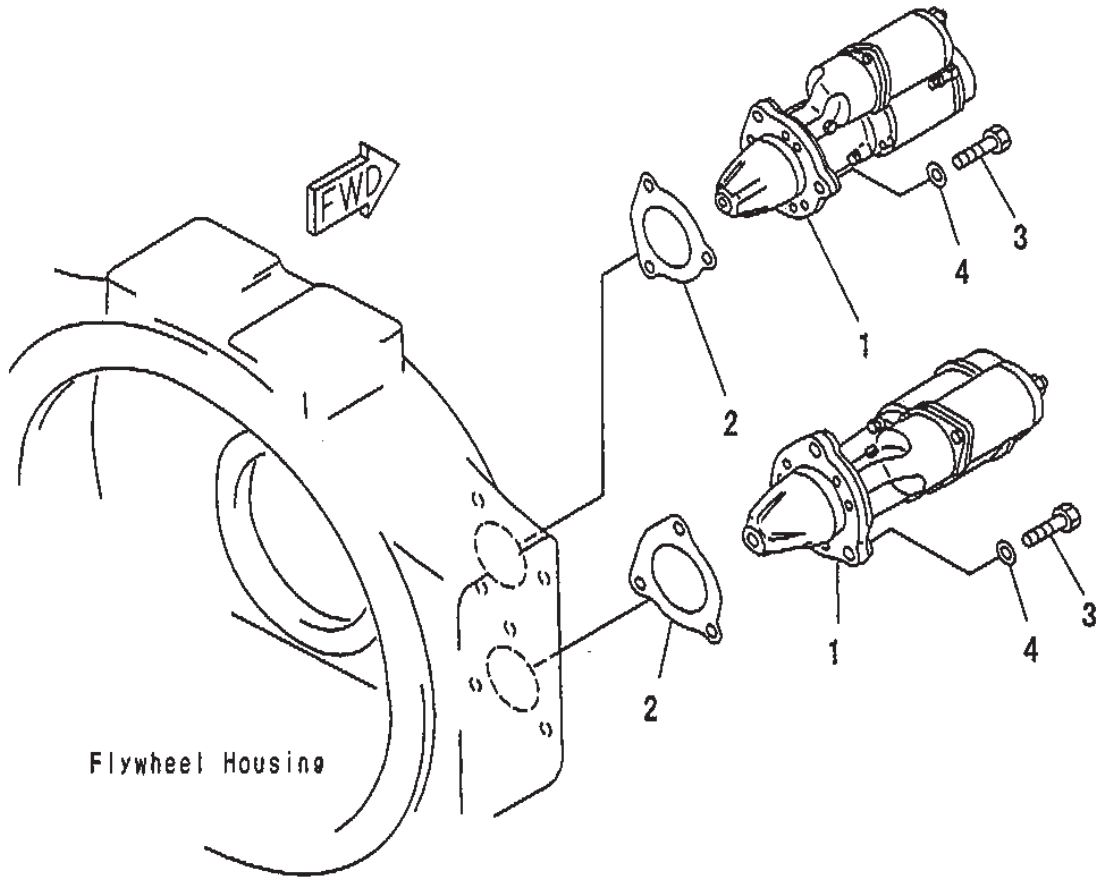

STARTER ASSY. (S/N 316346 AND ABOVE)

<u>NO.</u>	<u>PART NO.</u>	<u>PART NAME</u>	<u>QTY.</u>	<u>REMARKS</u>
1	6008133512	STARTING MOTOR ASSY. (7.5 KW)	2	
2	6221816810	GASKET	2	
3	0101061645	BOLT	6	
4	0164331645	WASHER	6	

ENGINE OPERATING PANEL ASSY.

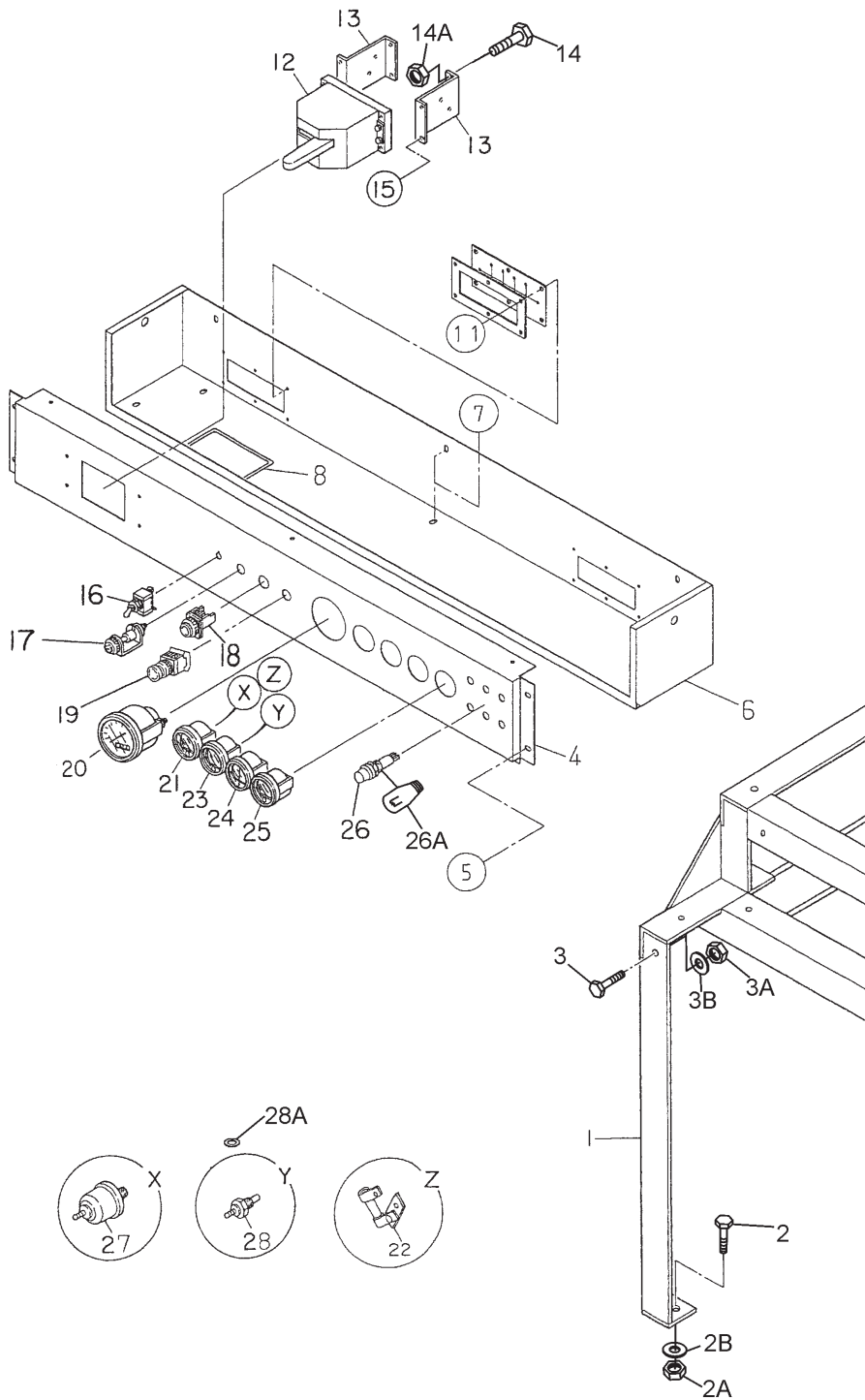

ENGINE OPERATING PANEL ASSY.

<u>NO.</u>	<u>PART NO.</u>	<u>PART NAME</u>	<u>QTY.</u>	<u>REMARKS</u>
1	C5484001202	SUPPORT LEG	1	
2	0017112045	HEX HEAD BOLT	4	
2A	0030012000	HEX NUT	4	
2B	0041212000	WASHER, FLAT	4	
3	0019210025	HEX HEAD BOLT	2	
3A	0205010000	HEX NUT	2	
3B	0042412000	WASHER, FLAT	2	
4	C5352101303	OPERATING PANEL	1	
5	0019208020	HEX HEAD BOLT	4	
6	C5352100213	OPERATING PANEL COVER	1	
7	0019208020	HEX HEAD BOLT	8	
8	0226900460	RUBBER SEAL	1	
9	8085182004	RUBBER COVER	1	
10	8085183004	RUBBER COVER SET FRAME	1	
11	0019206020	HEX HEAD BOLT	6	
12	0602101016	BATTERY SWITCH	1	
13	7522258304	BATTERY SWITCH BRACKET	2	
14	0017106030	HEX HEAD BOLT	4	
14A	0207006000	HEX NUT	4	
15	0019206015	HEX HEAD BOLT	4	
16	0601830710	ENGINE SPEED SWITCH	1	
17	K6008153730	PREHEAT INDICATOR.....	1REPLACES P/N 0602102055
18	0601830448	PREHEAT BUTTON	1	
19	0601831927	EMERGENCY STOP BUTTON	1	
20	0602120095	TACHOMETER	1	
21	0602122093	OIL PRESSURE GAUGE	1	
22	0601842450	VOLTAGE DIVIDER	1	
23	0602123092	WATER TEMPERATURE GAUGE	1	
24	0602121080	CHARGING AMMETER	1	
25	0602125091	FUEL GAUGE	1	
26	0602103090	ALARM LAMP	6	
26A	0601810244	BULB, DC28V	6	
27	0602122272	OIL PRESSURE UNIT FOR GAUGE	1	
28	0602123267	WATER TEMP. UNIT FOR GAUGE	1	
28A	0602021109	PACKING	1	

OUTPUT TERMINAL ASSY.

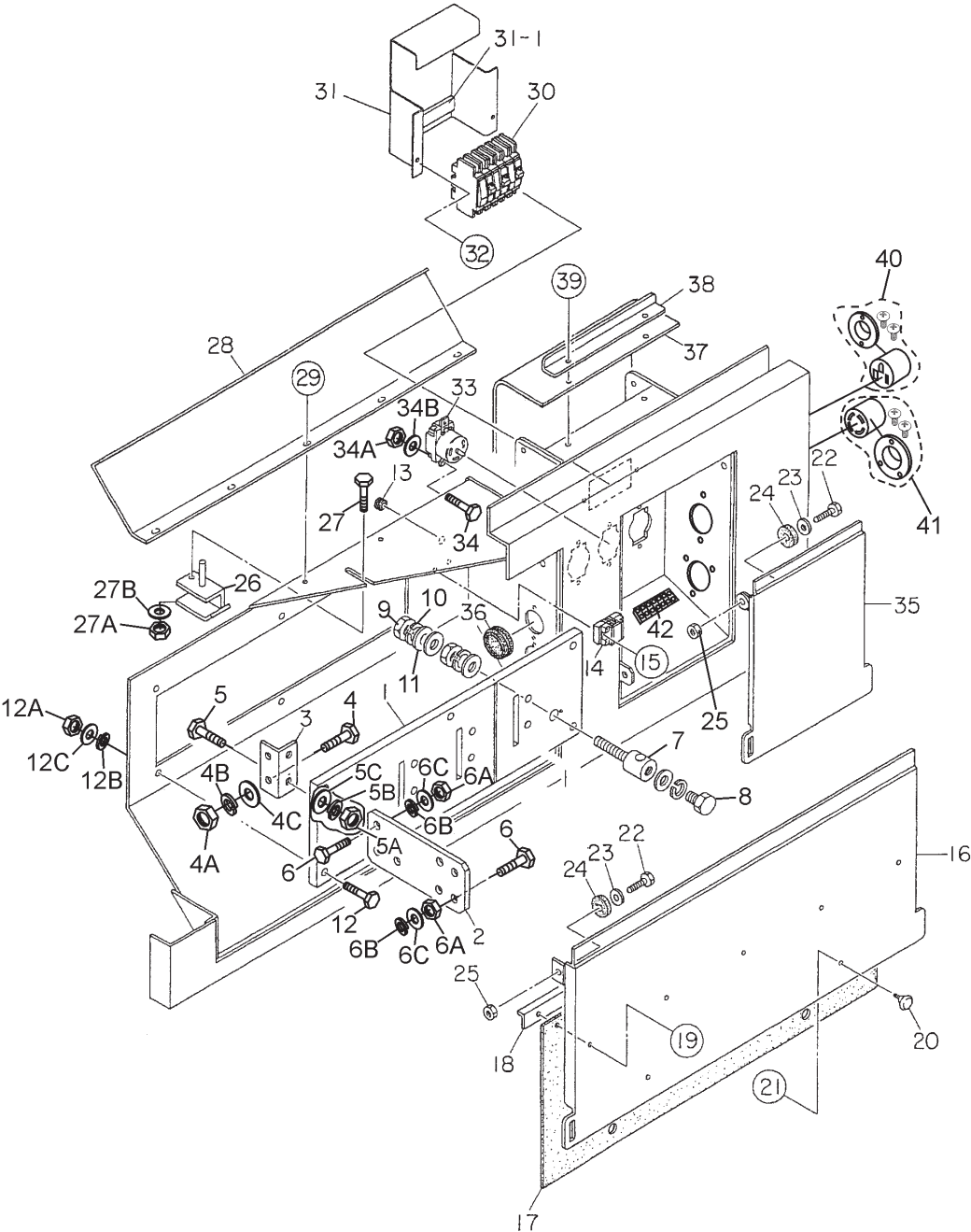

OUTPUT TERMINAL ASSY.

<u>NO.</u>	<u>PART NO.</u>	<u>PART NAME</u>	<u>QTY.</u>	<u>REMARKS</u>
1	C5231700003	OUTPUT TERMINAL SET BOARD	1	
2	7521860504	OUTPUT TERMINAL	4	
3	7521850504	OUTPUT TERMINAL BRACKET	4	
4	0010112040	HEX HEAD BOLT	8	
4A	0030012000	HEX NUT	8	
4B	0040012000	WASHER, LOCK	8	
4C	0041212000	WASHER, FLAT	16	
5	0010112060	HEX HEAD BOLT	8	
5A	0030012000	HEX NUT	8	
5B	0040012000	WASHER, LOCK	8	
5C	0041212000	WASHER, FLAT	16	
6	00101112040	HEX HEAD BOLT	24	
6A	0030012000	HEX NUT	24	
6B	0040012000	WASHER, LOCK	24	
6C	0041212000	WASHER, FLAT	48	
7	C5234000004	TERMINAL	1	
8	0801830904	HEX HEAD BOLT	1	
9	0039320000	HEX NUT	2	
10	0040020000	WASHER, LOCK	3	
11	0041420000	WASHER, FLAT	4	
12	0019112050	HEX HEAD BOLT	6	
12A	0042312000	WASHER, LOCK	6	
12B	0042412000	WASHER, FLAT	6	
13	0601850275	GROMMET	1	
14	0601815324	TERMINAL BOARD	1	
15	0027104020	MACHINE SCREW	2	
16	C4237101304	OUTPUT TERMINAL COVER	1	
17	7971867114	RUBBER SHEET	1	
18	7521865804	RUBBER SHEET SET PLATE	1	
19	0019206020	HEX HEAD BOLT	5	
20	0605010660	KNOB	2	
21	0207006000	HEX NUT	2	
22	0019212040	HEX HEAD BOLT	4	
23	0041212000	WASHER, FLAT	4	
24	0805009804	RUBBER STAY	4	
25	0030012000	HEX NUT	4	
26	7521865603	STOPPER	1	
27	0010108030	HEX HEAD BOLT	1	
27A	0030008000	HEX NUT	1	
27B	0041208000	WASHER, FLAT	2	
28	C4237100504	COVER	1	
29	0017108020	HEX HEAD BOLT	5	
30	0601808804	CIRCUIT BREAKER, 50A	3	

OUTPUT TERMINAL ASSY (CONTINUED).

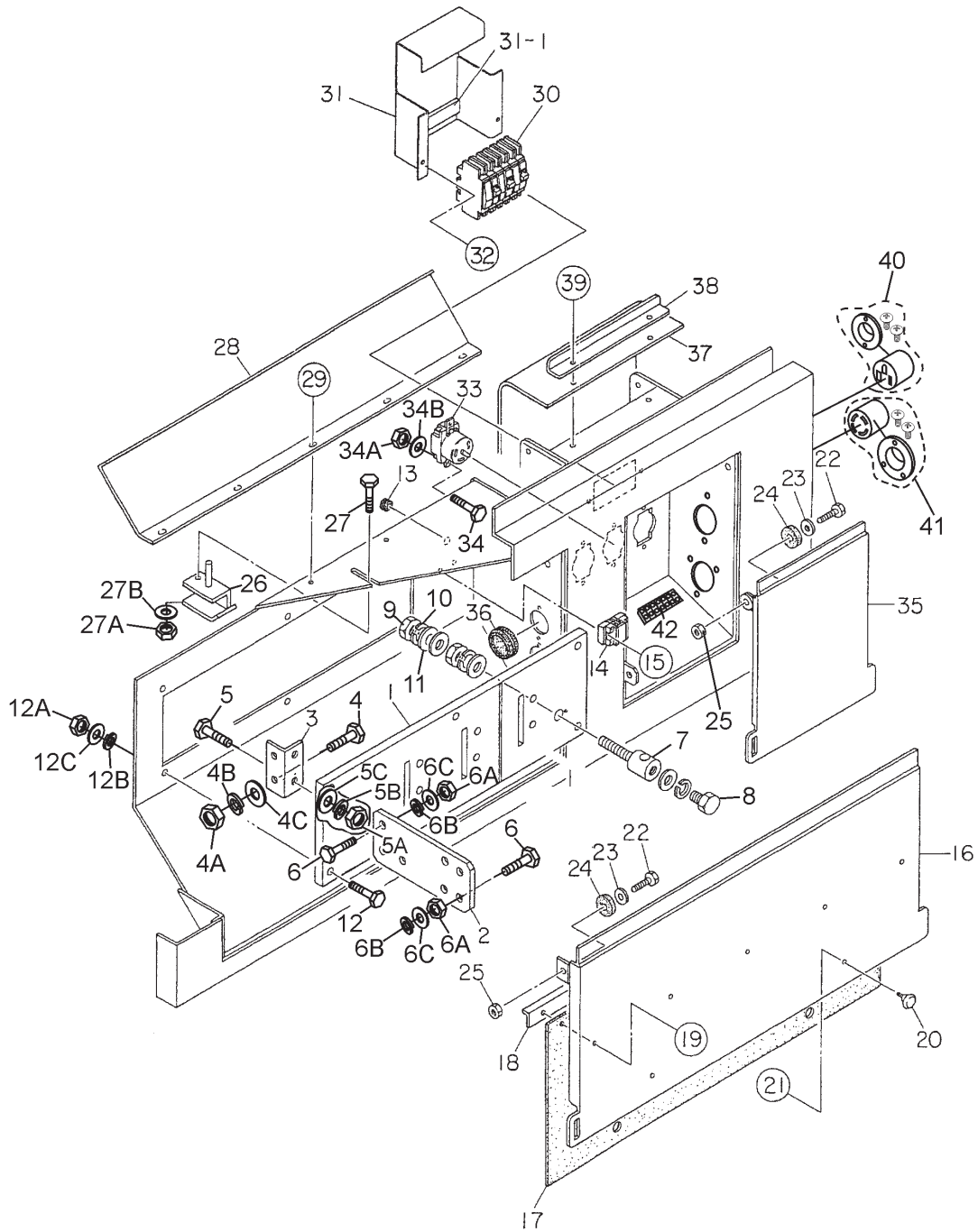

OUTPUT TERMINAL ASSY. (CONTINUED)

<u>NO.</u>	<u>PART NO.</u>	<u>PART NAME</u>	<u>QTY.</u>	<u>REMARKS</u>
31	C5261600204	CIRCUIT BREAKER BRACKET	1	
311	0221200110	RUBBER CUSHION	1	
32	0017106030	HEX HEAD BOLT	2	
33	0601811034	RECEPTACLE	3	
34	0027104015	MACHINE SCREW	6	
34A	0030004000	HEX NUT	6	
34B	0041204000	WASHER, FLAT	6	
35	C4237101203	COVER	1	
36	0601851780	GROMMET	2	
37	C4237102804	COVER	1	
38	C4237400804	BRACKET	1	
39	0017106016	HEX HEAD BOLT	2	

BATTERY ASSY.

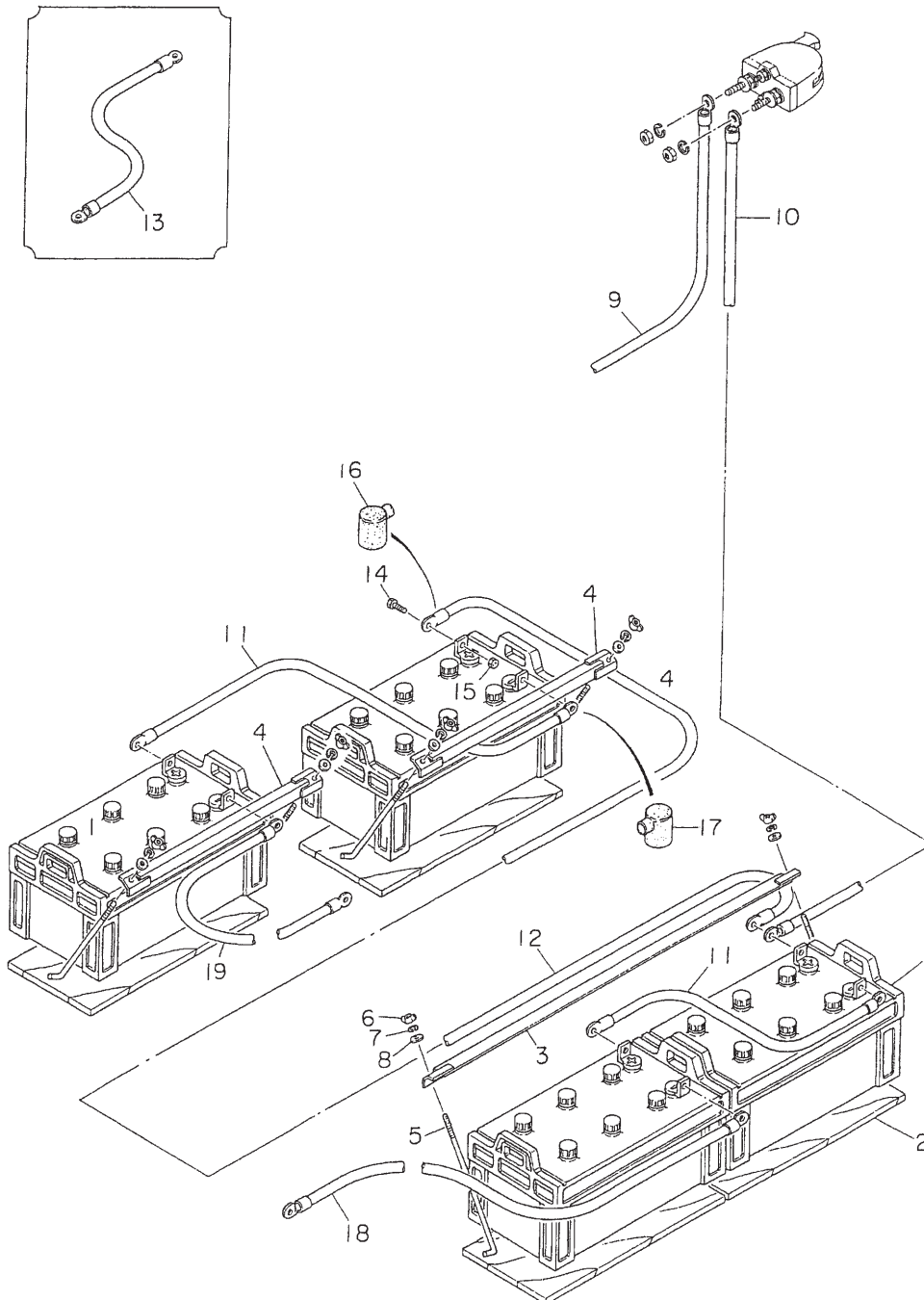

BATTERY ASSY.

<u>NO.</u>	<u>PART NO.</u>	<u>PART NAME</u>	<u>QTY.</u>	<u>REMARKS</u>
1	0165719052	BATTERY	4	
2	C9109100704	BATTERY SHEET	4	
3	0805006404	BATTERY BAND	1	
4	0805007804	BATTERY BAND	2	
5	0805006504	BATTERY BOLT	6	
6	0037808000	WING NUT	6	
7	0040008000	WASHER, LOCK	6	
8	0041608000	WASHER, FLAT	6	
9	C5347800504	BATTERY CABLE	1	
10	C5347800404	BATTERY CABLE	1	
11	7522280904	BATTERY CABLE	2	
12	C5347601404	BATTERY CABLE	1	
13	C5347400104	EARTH CABLE	1	
14	0347010030	HEX HEAD BOLT	8	
15	0208110000	HEX NUT	8	
16	0845040114	TERMINAL CAP (+)	4	
17	0845041004	TERMINAL CAP (-)	4	
18	C5347601304	BATTERY CABLE	1	
19	C5347601204	BATTERY CABLE	1	

MUFFLER ASSY.

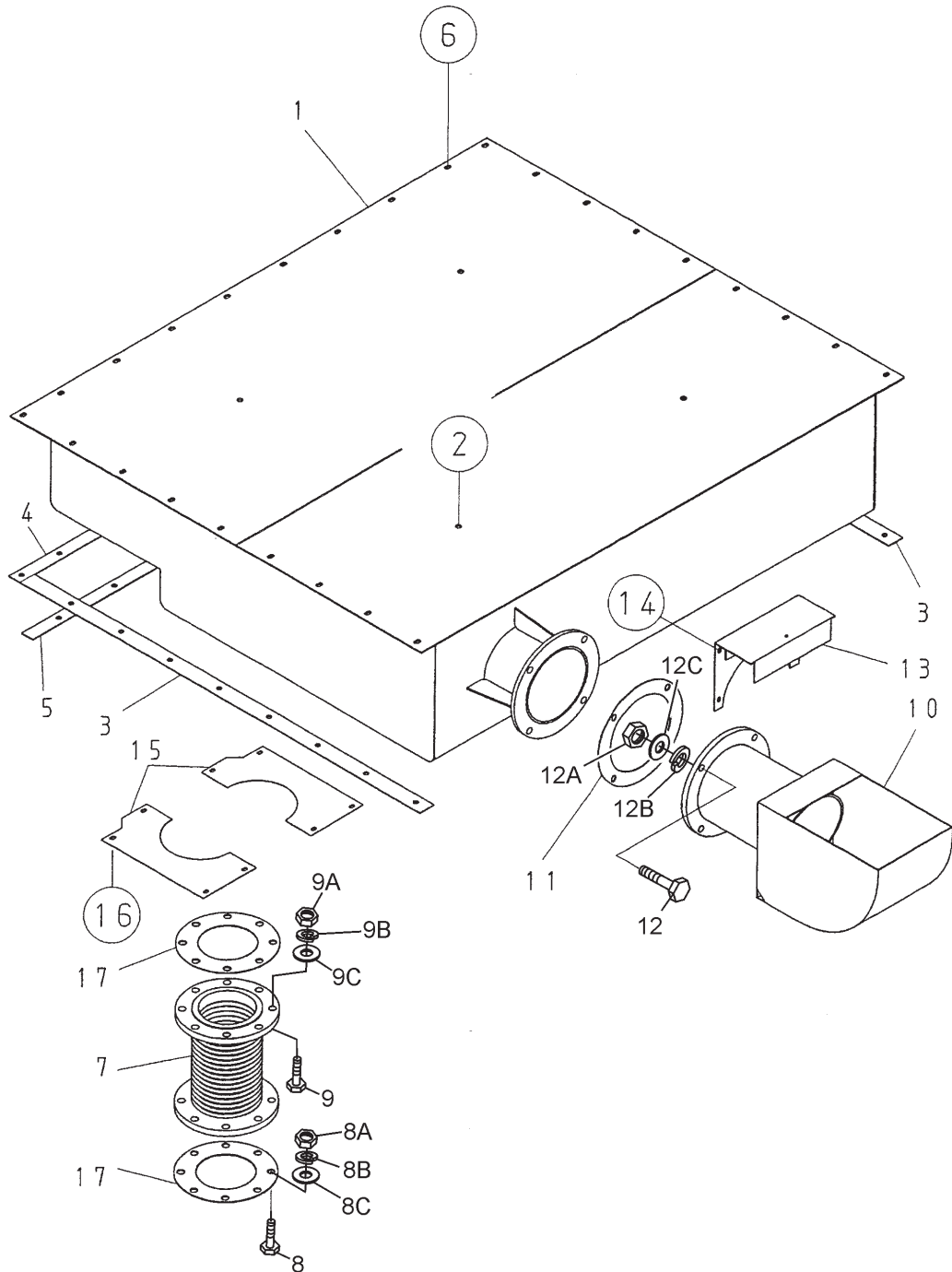

MUFFLER ASSY.

<u>NO.</u>	<u>PART NO.</u>	<u>PART NAME</u>	<u>QTY.</u>	<u>REMARKS</u>
1	C5331100302	MUFFLER	1	
2	0019212030	HEX HEAD BOLT	4	
3	C5334200704	PACKING	2	
4	C5335200204	PACKING	1	
5	C5335200304	PACKING	1	
6	0019210035	HEX HEAD BOLT	26	
7	C5334000403	EXHAUST PIPE	2	
8	0010116070	HEX HEAD BOLT	8	
8A	0030016000	HEX NUT	8	
8B	0040016000	WASHER, LOCK	8	
8C	0041616000	WASHER, FLAT	16	
9	0010116050	HEX HEAD BOLT	8	
9A	0040016000	WASHER, LOCK	8	
9B	0041616000	WASHER, FLAT	8	
10	C5334101503	OUTLET PIPE	1	
11	C5335200004	GASKET	1	
12	0010116070	HEX HEAD BOLT	4	
12A	0030016000	HEX NUT	4	
12B	0040016000	WASHER, LOCK	4	
12C	0041616000	WASHER, FLAT	8	
13	C5331300304	COVER	1	
14	0019208020	HEX HEAD BOLT	4	
15	C5331400104	COVER	2	
16	0019208020	HEX HEAD BOLT	8	
17	C4334200504	GASKET	2	

FUEL TANK ASSY.

<u>NO.</u>	<u>PART NO.</u>	<u>PART NAME</u>	<u>QTY.</u>	<u>REMARKS</u>
1	C5364001003	FUEL TANK	1	
11	0845500104	FUEL TANK CAP	1	
12	0810105400	FUEL FILTER	1	
13	0264100525	FUEL GAUGE HOSE	1	
14	0605515079	HOSE BAND	2	
2	0605503023	FUEL SENSOR	1	
3	0802120604	PACKING	1	
4	0605501093	FUEL UNIT	1	
5	0022905015	PACKING	1	
6	0605516090	MACHINE SCREW	5	
7	C6364200104	TANK BAND	2	
8	0805003414	TANK BAND PAD	4	
9	0017108020	HEX HEAD BOLT	2	
10	0207308000	HEX NUT	2	
11	0222100600	TANK SHEET	6	
12	0130206000	STREET ELBOW	1	
13	0134306370	DRAIN PIPE	1	
14	0603325026	VALVE	1	
15	0132006000	PLUG	1	
16	C1367700304	LOCK PLATE	1	
17	0019208020	HEX HEAD BOLT	2	
18	0130008000	ELBOW	2	
19	0602022225	HOSE JOINT	6	
20	0605515074	HOSE BAND	6	
21	0265803400	SUCTION HOSE	1	
22	0265801900	SUCTION HOSE	1	
23	6240715690	RETURN HOSE	1	REPLACES P/N 0605514120
24	0265803900	RETURN HOSE	1	
25	0845039604	RUBBER SEAL	1	
26	0010110100	HEX HEAD BOLT	3	
27	0040010000	WASHER, LOCK	3	
28	0041610000	WASHER, FLAT	3	
29	0131108000	SOCKET	4	
30	6003193320	FUEL FILTER CARTRIDGE	2	REPLACES P/N 0602042583

ENCLOSURE ASSY.#1

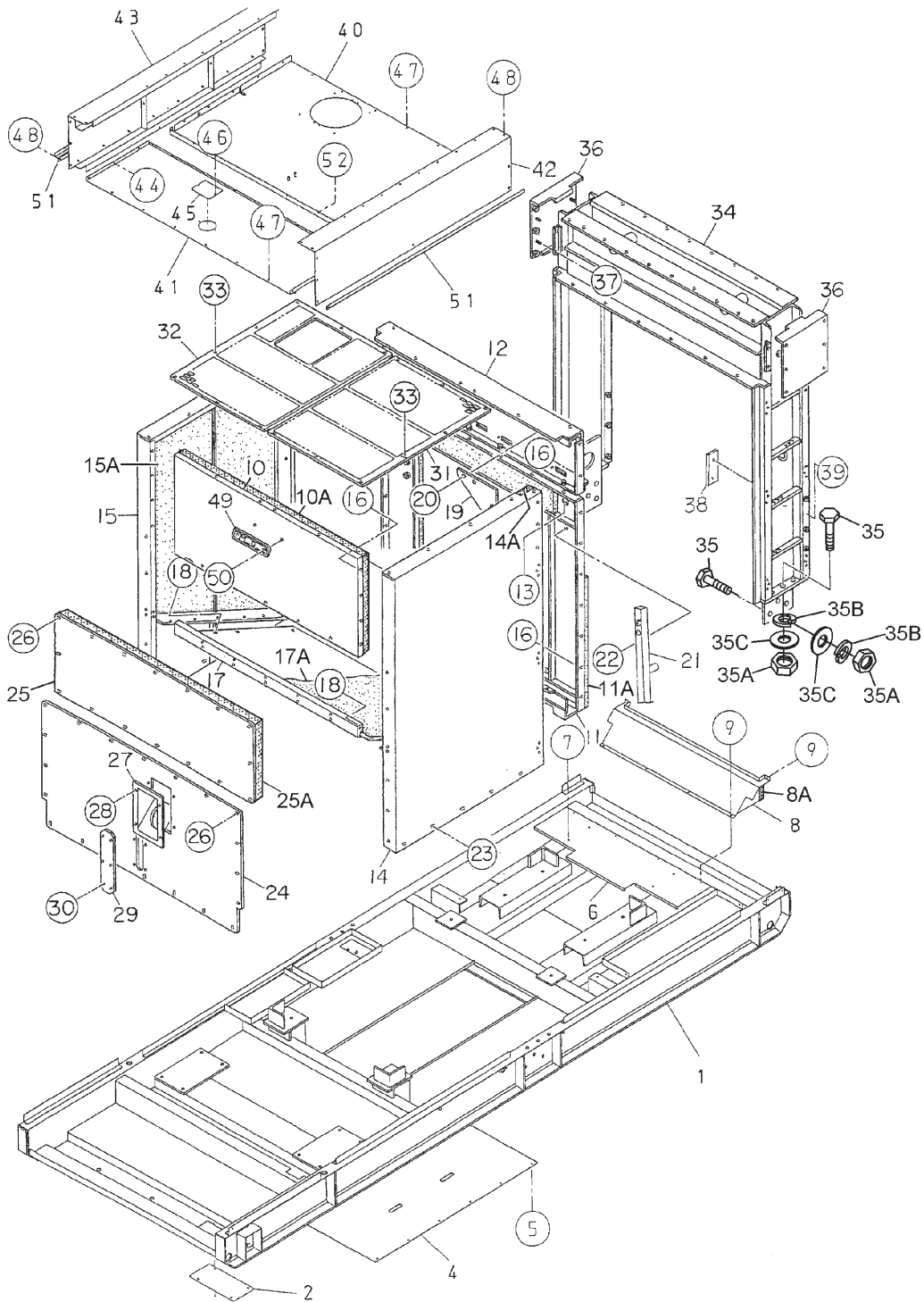

ENCLOSURE ASSY. #1

<u>NO.</u>	<u>PART NO.</u>	<u>PART NAME</u>	<u>QTY.</u>	<u>REMARKS</u>
1	C5414001502	BASE	1	
2	C5414100204	FLOOR PANEL	1	
3	0019208020	HEX HEAD BOLT	4	
4	C5414100104	FLOOR PANEL	1	
5	0019208020	HEX HEAD BOLT	12	
6	C5414600403	AIR GUIDE PANEL	1	
7	0019208020	HEX HEAD BOLT	4	
8	C5414600503	BASE DUCT	1	
8A	C5494000204	LINING	1	
9	0019208020	HEX HEAD BOLT	6	
10	C5424002803	FRONT FRAME	1	
10A	C5494100603	LINING	1	
11	C5424003003	FRONT FRAME	1	
11A	C5494100603	LINING	1	
12	C5424002903	FRONT FRAME	1	
13	0019208020	HEX HEAD BOLT	6	
14	C5424002402	FRONT FRAME	1	
14A	C5494100603	LINING	1	
15	C5424002502	FRONT FRAME	1	
15A	C5494100603	LINING	1	
16	0019208020	HEX HEAD BOLT	28	
17	C5424002603	AIR GUIDE PANEL	1	
17A	C5494100603	LINING	1	
18	0019208020	HEX HEAD BOLT	18	
19	C5424002704	GUSSET	2	
20	0019210025	HEX HEAD BOLT	8	
21	C5327100504	BREATHER PIPE	1	
22	0016908020	HEX HEAD BOLT	1	
23	0019210025	HEX HED BOLT	8	
24	C5424201803	FRONT FRAME COVER	1	
25	C5424202103	FRONT FRAME COVER	1	
25A	C5494100704	LINING	1	

ENCLOSURE ASSY. #1 (CONTINUED)

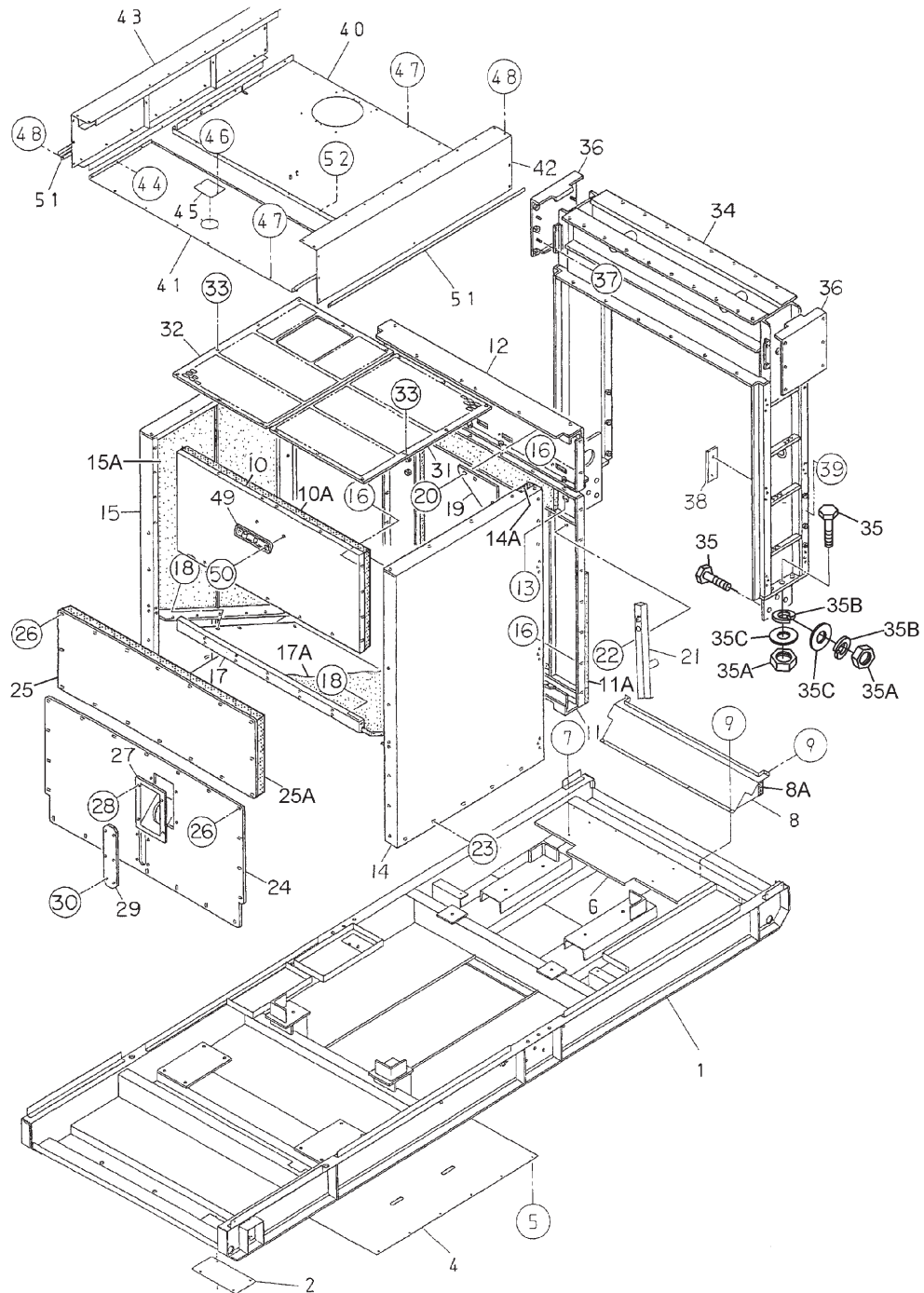

ENCLOSURE ASSY.#1 (CONTINUED)

<u>NO.</u>	<u>PART NO.</u>	<u>PART NAME</u>	<u>QTY.</u>	<u>REMARKS</u>
26	0019208020	HEX HEAD BOLT	36	
27	0845042703	FILLER BRACKET	1	
28	0019208020	HEX HEAD BOLT	4	
29	C4424204604	COVER	1	
30	0019206020	HEX HEAD BOLT	6	
31	C5424201903	FRONT FRAME COVER	1	
32	C5424202003	FRONT FRAME COVER	1	
33	0019208020	HEX HEAD BOLT	16	
34	C5434000702	CENTER FRAME	1	
35	0010120075	HEX HEAD BOLT	16	
35A	0040030000	HEX NUT	16	
35B	0040020000	WASHER, LOCK	16	
35C	0041620000	WASHER, FLAT	16	
36	C5434200003	COVER	2	
37	0207008000	HEX NUT	8	
38	C2367700404	COVER	1	
39	0019208020	HEX HEAD BOLT	2	
40	C5464101603	ROOF PANEL	1	
41	C5464101703	ROOF PANEL	1	
42	C5464101403	ROOF PANEL	1	
43	C5464101503	ROOF PANEL	1	
44	0207108000	HEX NUT	16	
45	8452023004	FILLER COVER	1	
46	0019208020	HEX HEAD BOLT	2	
47	0019208020	HEX HEAD BOLT	12	
48	0019210025	HEX HEAD BOLT	22	
49	0600500090	EMBLEM	1	
50	0021106016	MACHINE SCREW	2	
51	C5464500304	BRACKET	2	
52	0019206020	HEX HEAD BOLT	6	

ENCLOSURE ASSY. #2

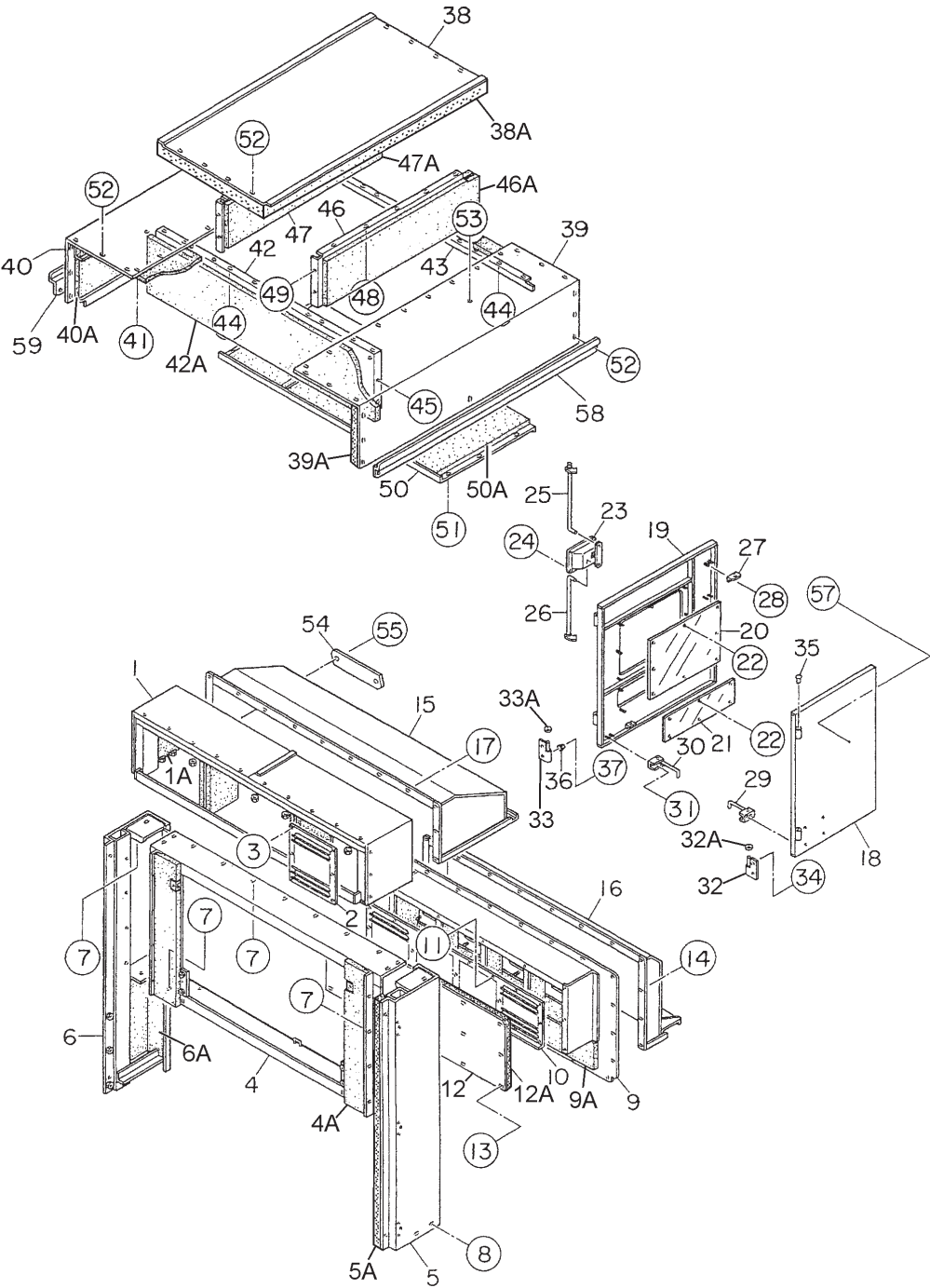

ENCLOSURE ASSY. #2

<u>NO.</u>	<u>PART NO.</u>	<u>PART NAME</u>	<u>QTY.</u>	<u>REMARKS</u>
1	C5444001403	REAR FRAME	1	
1A	C5494300104	LINING	1	
2	7525151004	LOUVER PANEL	5	
3	0207106000	HEX NUT	40	
4	C5444001303	REAR FRAME	1	
4A	C5494300604	LINING	1	
5	C5444001103	REAR FRAME	1	
5A	C5494300604	LINING	1	
6	C5444001203	REAR FRAME	1	
6A	C5494300604	LINING	1	
7	0017110020	HEX HEAD BOLT	21	
8	0019110025	HEX HEAD BOLT	4	
9	C5444300703	REAR FRAME COVER	1	
9A	C5494300704	LINING	1	
10	7525151804	LOUVER PANEL	1	
11	0207106000	HEX NUT	21	
12	C5444300804	DUCT COVER	1	
12A	C5494300804	LINING	1	
13	0017108020	HEX HEAD BOLT	15	
14	0019208020	HEX HEAD BOLT	21	
15	C5444300303	VISOR	1	
16	7525165603	VISOR	1	
17	0019208020	HEX HEAD BOLT	13	
18	C5444200503	REAR DOOR FRAME	1	
19	C5444200003	REAR DOOR FRAME	1	
20	7525147014	WINDOW PLATE	1	
21	7525147114	WINDOW PLATE	1	
22	0207306000	HEX NUT	14	
23	B9114000102	DOOR HANDLE	1	
24	0021806016	MACHINE SCREW	4	
25	7525146404	DOOR ROD	1	
26	7525146504	DOOR ROD	1	
27	0845050704	STAY	4	
28	0207106000	HEX NUT	8	
29	0805011304	DOOR STOPPER	1	
30	0805011204	DOOR STOPPER	1	
31	0207106000	HEX NUT	4	
32	0845047104	HINGE	2	
32A	0845045004	WASHER	2	
33	0845047204	HINGE	2	
33A	0845045004	WASHER	2	
34	0019208020	HEX HEAD BOLT	4	
35	0845031504	CAP	4	
36	0601850097	STOPPER	4	

ENCLOSURE ASSY. #2 (CONTINUED)

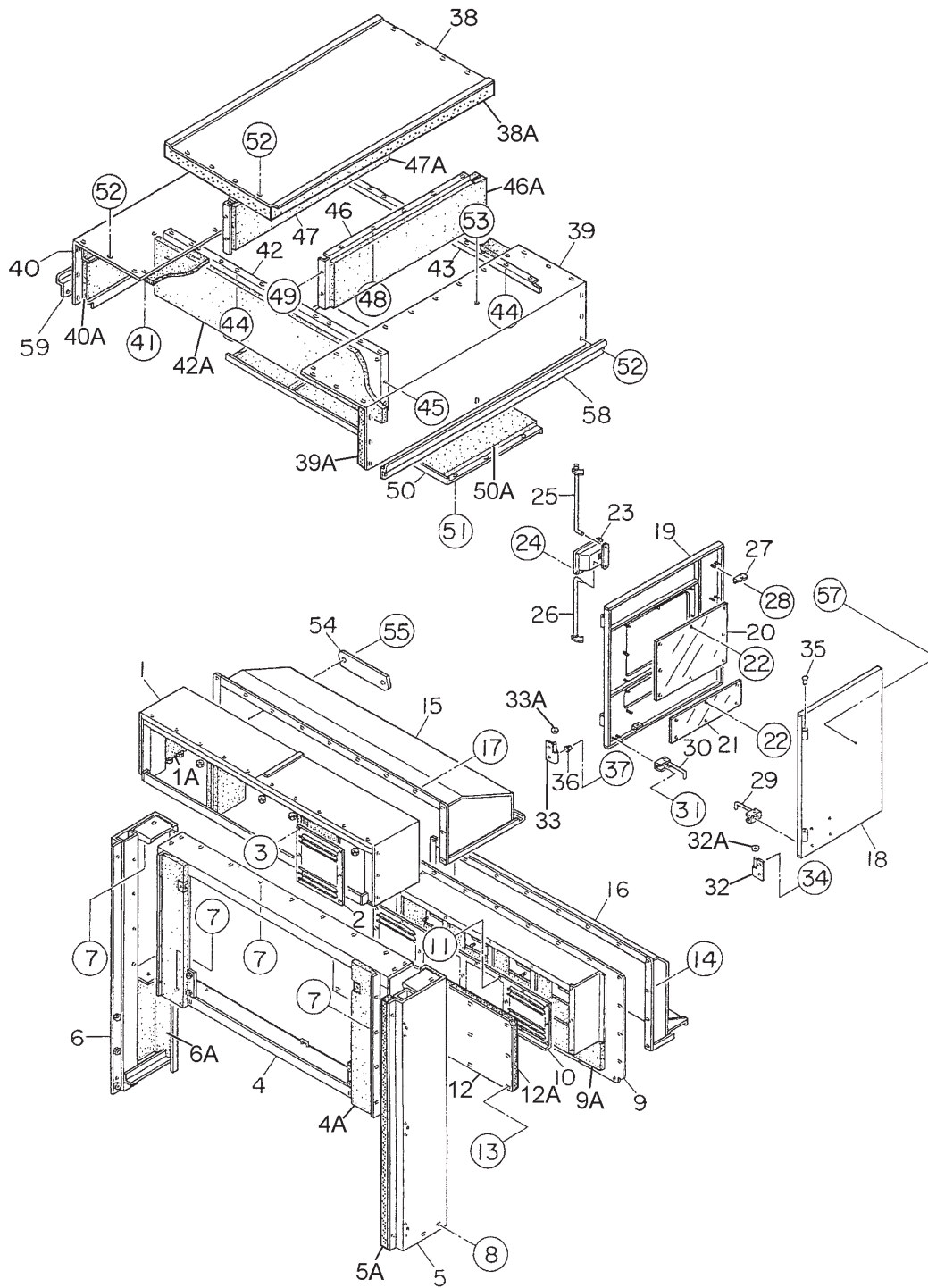

ENCLOSURE ASSY. #2 (CONTINUED)

<u>NO.</u>	<u>PART NO.</u>	<u>PART NAME</u>	<u>QTY.</u>	<u>REMARKS</u>
37	0025408025	MACHINE SCREW	4	
38	C5464201403	ROOF PANEL	1	
38A	C5494500503	LINING	1	
39	C5464201503	ROOF PANEL	1	
39A	C5494500503	LINING	1	
40	C5464201603	ROOF PANEL	1	
40A	C5494500503	LINING	1	
41	0207008000	HEX NUT	18	
42	C5464200504	PANEL	1	
42A	C5494500503	LINING	1	
43	C5464200604	GUIDE	1	
44	0207008000	HEX NUT	20	
45	0017108020	HEX HEAD BOLT	4	
46	C5464200404	PANEL	1	
46A	C5494500503	LINING	1	
47	C5464200304	PANEL	1	
47A	C5494500503	LINING	1	
48	0207008000	HEX NUT	10	
49	0017108020	HEX HEAD BOLT	4	
50	C5464400004	ROOF PANEL COVER	1	
50A	C5494500604	LINING	1	
51	0017108020	HEX HEAD BOLT	12	
52	0019210030	HEX HEAD BOLT	34	
53	0019212030	HEX HEAD BOLT	4	
54	0600500090	EMBLEM	1	
55	0021106016	MACHINE SCREW	2	
57	0207106000	HEX NUT	4	
58	C5464500404	BRACKET	1	
59	C5464500504	BRACKET	1	

ENCLOSURE ASSY. #3

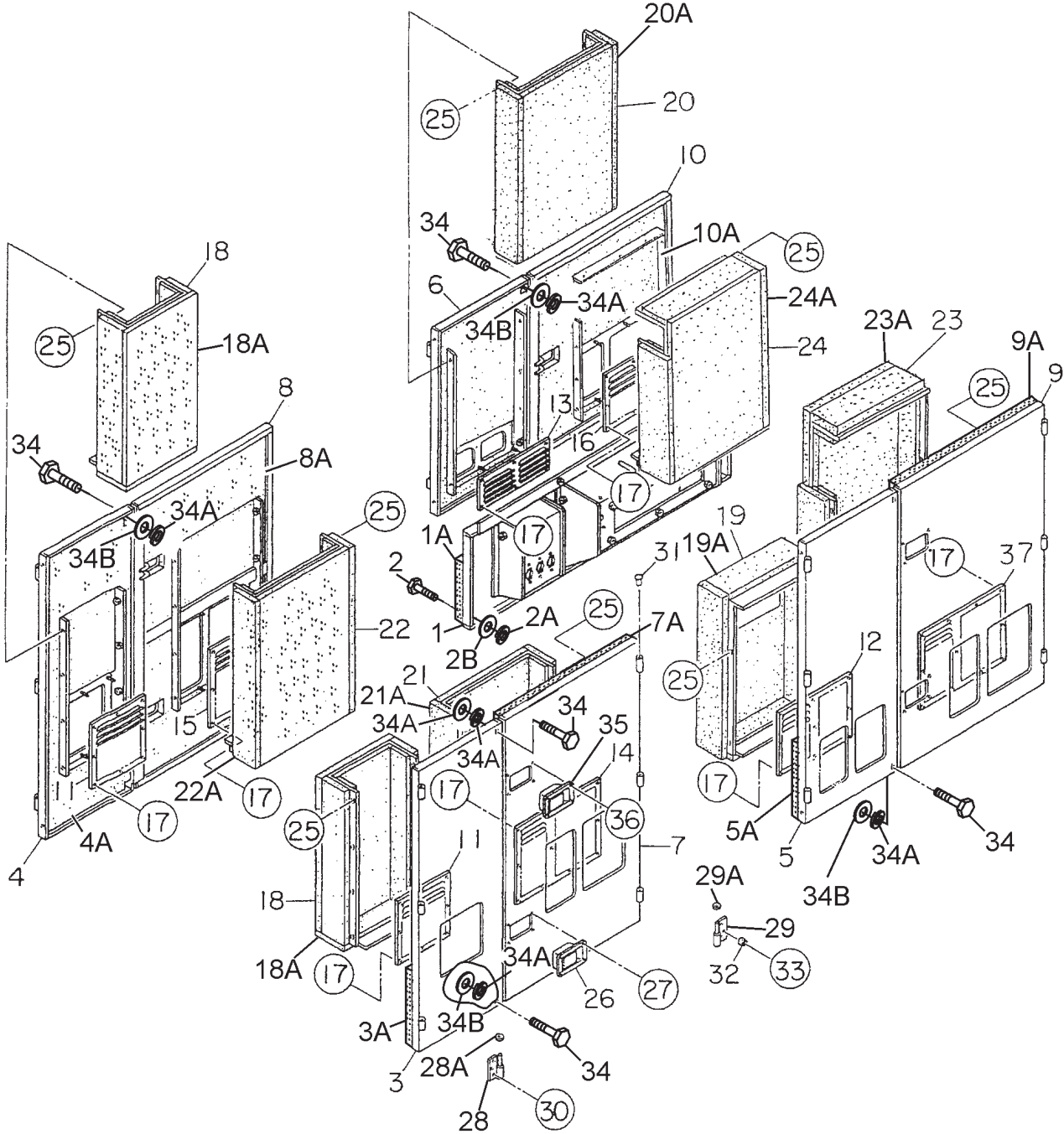

ENCLOSURE ASSY. #3

<u>NO.</u>	<u>PART NO.</u>	<u>PART NAME</u>	<u>QTY.</u>	<u>REMARKS</u>
1	C5454202603	SPLASHER PANEL	1	
1A	C5494405704	LINING	1	
2	0019110065	HEX HEAD BOLT	6	
2A	0042310000	WASHER, LOCK	6	
2B	0042410000	WASHER, FLAT	6	
3	C5454101703	SIDE PANEL	1	
3A	C5494400904	LINING	1	
4	C5454101803	SIDE PANEL	1	
4A	C5494405004	LINING	1	
5	C5454101903	SIDE PANEL	1	
5A	C5494405104	LINING	1	
6	C5454102003	SIDE PANEL	1	
6A	C5494405204	LINING	1	
7	C5454001903	SIDE DOOR	1	
7A	C5494404504	LINING	1	
8	C5454002003	SIDE DOOR	1	
8A	C5494404604	LINING	1	
9	C5454002103	SIDE DOOR	1	
9A	C5494404704	LINING	1	
10	C5454002203	SIDE DOOR	1	
10A	C5494404804	LINING	1	
11	C5454700304	LOUVER PANEL	2	
12	7525151604	LOUVER PANEL	1	
13	C5454700404	LOUVER PANEL	1	
14	7525151304	LOUVER PANEL	1	
15	7525151404	LOUVER PANEL	1	
16	C5454700204	LOUVER PANEL	1	
17	0207106000	HEX NUT	74	
18	C5454301004	DUCT	2	
18A	C5494405504	LINING	1	
18B	C5494405804	LINING	1	
19	C5454300704	DUCT	1	
19A	C5494403904	LINING	1	
20	C5454301104	DUCT	1	
20A	C5494405604	LINING	1	

ENCLOSURE ASSY. #3 (CONTINUED)

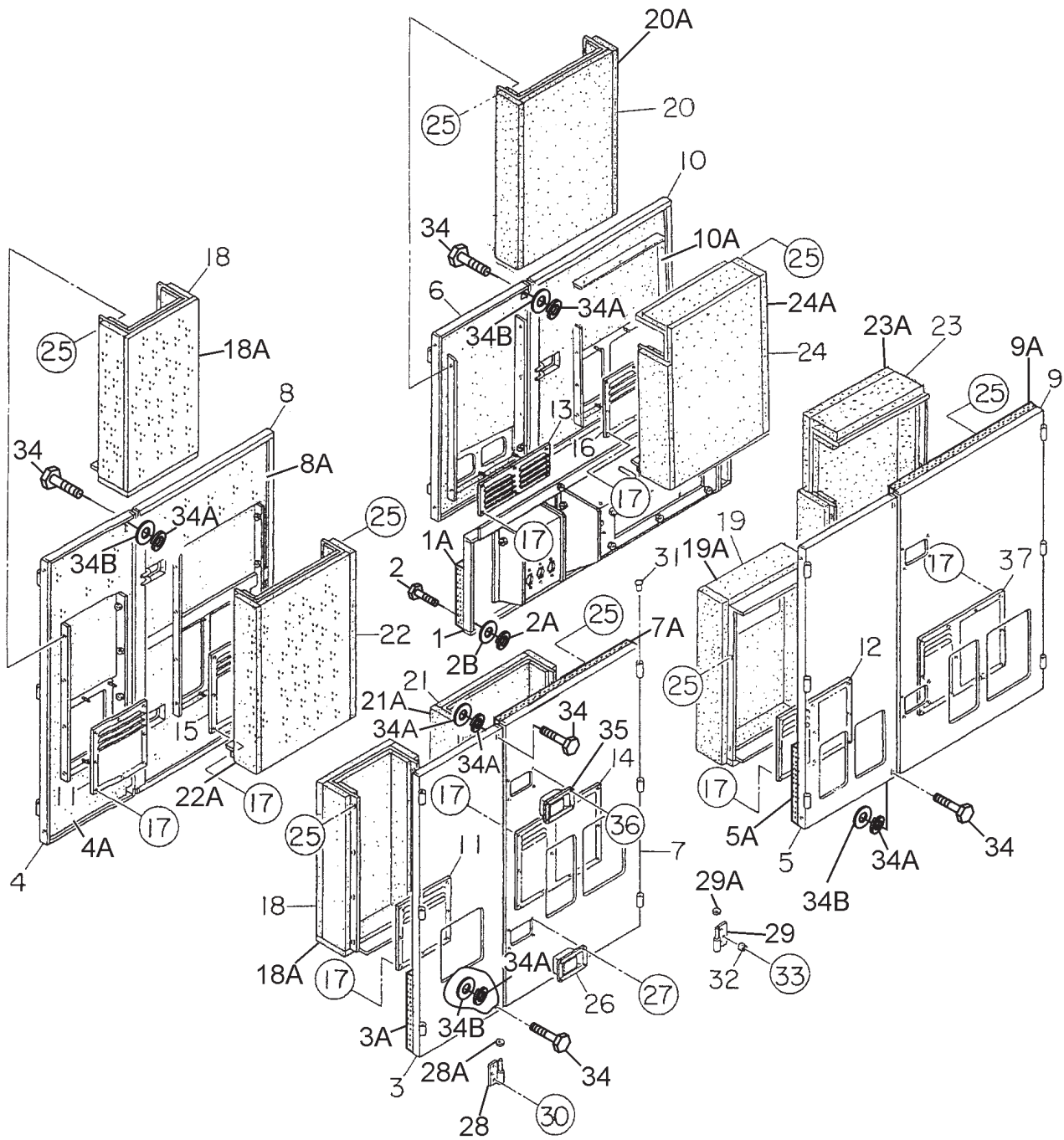

ENCLOSURE ASSY. #3 (CONTINUED)

<u>NO.</u>	<u>PART NO.</u>	<u>PART NAME</u>	<u>QTY.</u>	<u>REMARKS</u>
21	C5454300604	DUCT	1	
21A	C5494405904	LINING	1	
22	C5454300904	DUCT	1	
22A	C5494405904	LINING	1	
23	C5454300804	DUCT	1	
23A	C5494405304	LINING	1	
24	C5454300904	DUCT	1	
24A	C5494405404	LINING	1	
25	0019208020	HEX HEAD BOLT	71	
26	0825007362	DOOR HANDLE	3	
27	0021806016	MACHINE SCREW	12	
28	0845046904	HINGE	11	
28A	0845045004	WASHER	11	
29	0845049004	HINGE	11	
29A	0845045004	WASHER	11	
30	0019208020	HEX HEAD BOLT	44	
31	0845031504	CAP	22	
32	0601850097	STOPPER	16	
33	0025408025	MACHINE SCREW	22	
34	0019110065	HEX HEAD BOLT	8	
34A	0042310000	WASHER, LOCK	8	
34B	0042410000	WASHER, FLAT	8	
35	B9114000002	DOOR HANDLE	4	
36	0021806016	MACHINE SCREW	16	
37	C5454700104	LOUVER PANEL	1	

RUBBER SEALS ASSY.

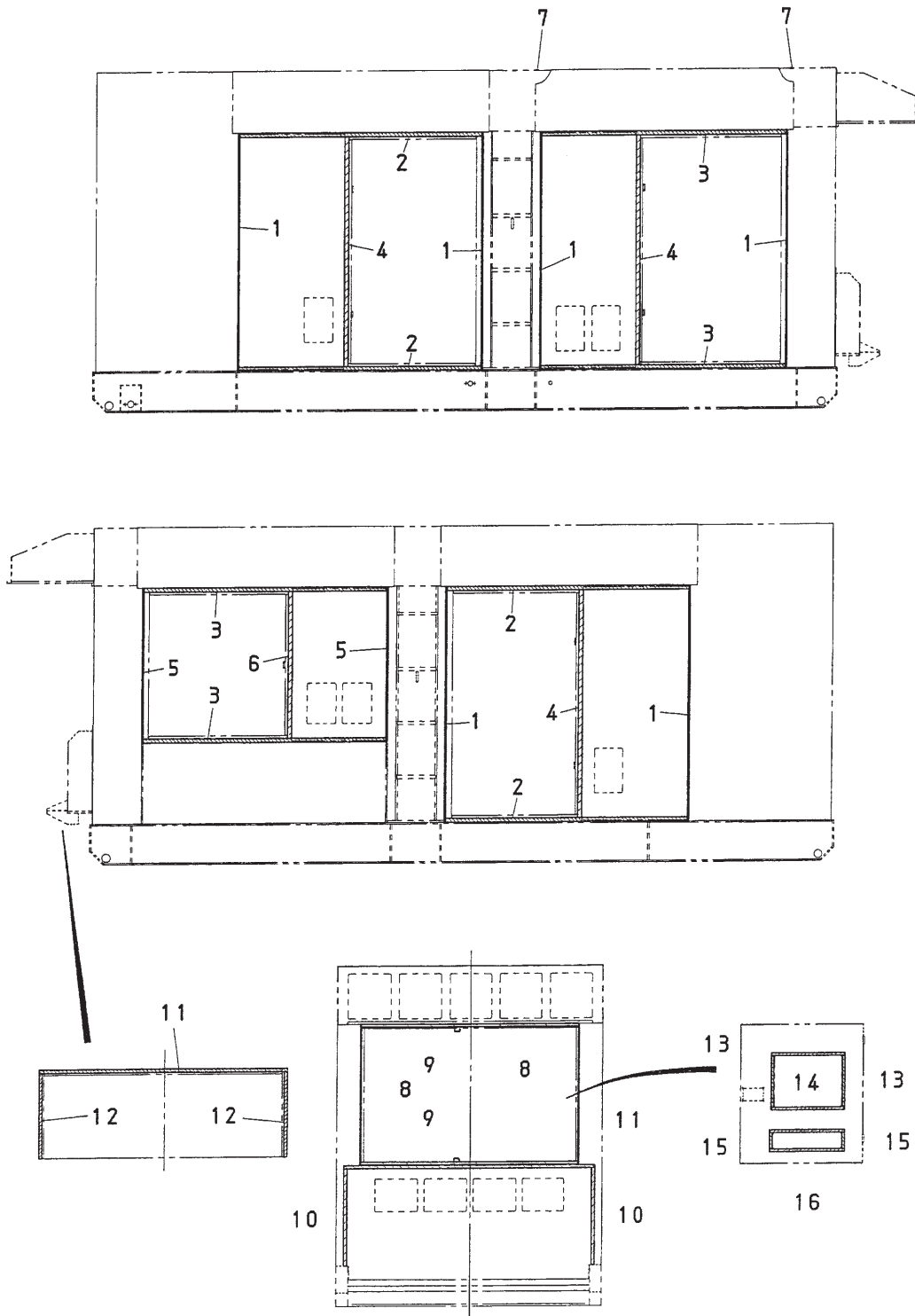

RUBBER SEALS ASSY.

<u>NO.</u>	<u>PART NO.</u>	<u>PART NAME</u>	<u>QTY.</u>	<u>REMARKS</u>
1	0228901750	RUBBER SEAL	6	
2	0228901780	RUBBER SEAL	4	
3	0228901800	RUBBER SEAL	4	
4	0228901690	RUBBER SEAL	3	
5	0228901150	RUBBER SEAL	2	
6	0228801090	RUBBER SEAL	1	
7	0229201950	RUBBER SEAL	2	
8	0221201030	RUBBER SEAL	2	
9	0228801600	RUBBER SEAL	2	
10	0229200710	RUBBER SEAL	2	
11	0229201840	RUBBER SEAL	2	
12	0229200625	RUBBER SEAL	2	
13	0228100380	RUBBER SEAL	2	
14	0228100550	RUBBER SEAL	2	
15	0228100120	RUBBER SEAL	2	
16	0228100560	RUBBER SEAL	2	

NAMEPLATE AND DECALS ASSY.

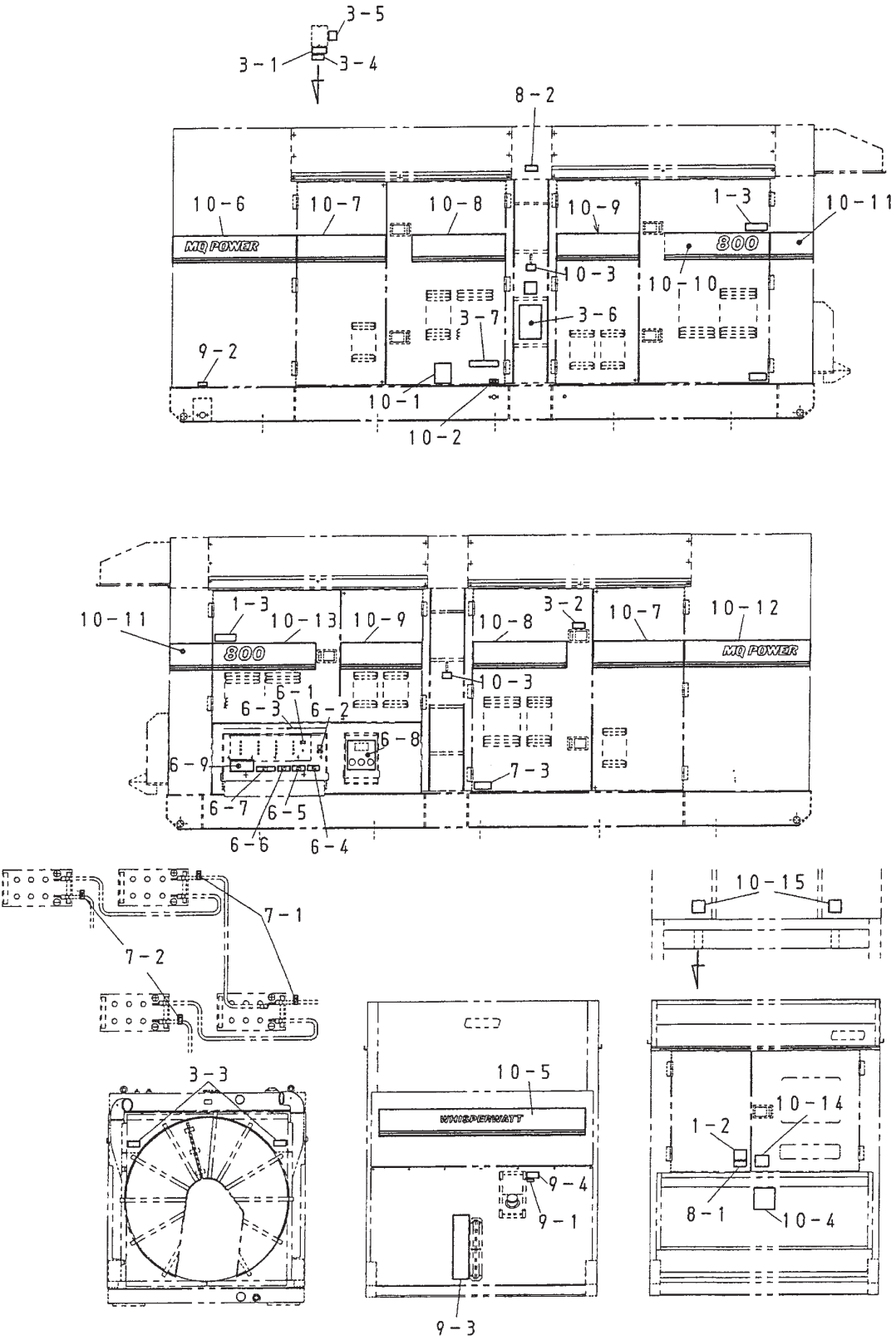

NAMEPLATE AND DECALS ASSY.

<u>NO.</u>	<u>PART NO.</u>	<u>PART NAME</u>	<u>QTY.</u>	<u>REMARKS</u>
12	B9521100404	DECAL : SAFETY INSTRUCTIOS	1	B92110040
13	B1552000103	DECAL : CAUTION.....	2	B15200010
CONTROL PANEL & BOX GROUP				
21	0800520100	PLATE : ON OFF	1	AT 202
22	0800520904	PLATE : AMMETER CHANGE OVER SWITCH	1	N2438
23	0800520814	PLATE : VOLTMETER CHANGE OVER SWITCH.....	1	N2439
24	0800564004	PLATE : OFF	2	N3805
25	0800565004	PLATE : ON	2	N3806
26	0840624504	DECAL : CIRCUIT BREAKER.....	1	S3031
27	0840624604	DECAL : PANEL LIGHT SWITCH	1	S3032
28	0840624704	DECAL : PILOT LAMP.....	1	S3033
29	0840624804	DECAL : VOLTAGE REGULATOR	1	S3034
210	B9531100604	DECAL : WARNING ELECTRIC SHOCK HAZARD	2	B93110060
211	C5551000303	DECAL : SETTING FOR OUTPUT VOLTAGE.....	1	C55100030
212	C5561101003	DECAL : WHISPERWATT 800	1	C56110010
ENGINE & RADIATOR GROUP				
31	0800689204	DECAL : COOLING WATER.....	1	S961
32	B9504000304	DECAL : CAUTION HOT PARTS.....	1	B90400030
33	B9504000404	DECAL : WARNING MOVING PARTS.....	2	B90400040
34	B9504100104	DECAL : WARNING HOT COOLANT.....	1	B90410010
35	0600501100	DECAL : WARNING.....	1	0600501100
36	0966810000	DECAL : FUEL PRIMING	1	
ENGINE OPERATING PANEL GROUP				
51	C5551001203	DECAL : OPERATING PANEL	1	C55100120
51A	0840647804	DECAL : EMERGENCY STOP.....	1	S4100
52	C5551001104	DECAL : WARNING LAMP	1	C55100110A
53	C0551000504	DECAL : BATTERY SWITCH	1	C05100050
OUTPUT TERMINAL GROUP				
61	0840614104	DECAL : GROUND.....	1	S2635
62	9039209064	DECAL : START CONTACT	1	S4468
63	0840655704	DECAL : TERMINAL COVER STOPPER.....	1	S4516
64	B9511100304	DECAL : WARNING.....	1	B91110030
65	B9511100404	DECAL : WARNING ELECTRIC SHOCK HAZARD	1	B93110050
66	B9531100504	DECAL : WARNING ELECTRIC SHOCK HAZARD	1	B93110050
67	C0551000404	DECAL : 3 PHASE OUTPUT TERMINAL.....	1	C05100040
68	C5551000403	DECAL : RECEPTACLE & CIRCUIT BREAKER.....	1	C55100040
69	0840619904	DECAL : DANGER HIGH VOLTAGE.....	1	S2731

NAMEPLATE AND DECALS ASSY (CONTINUED)

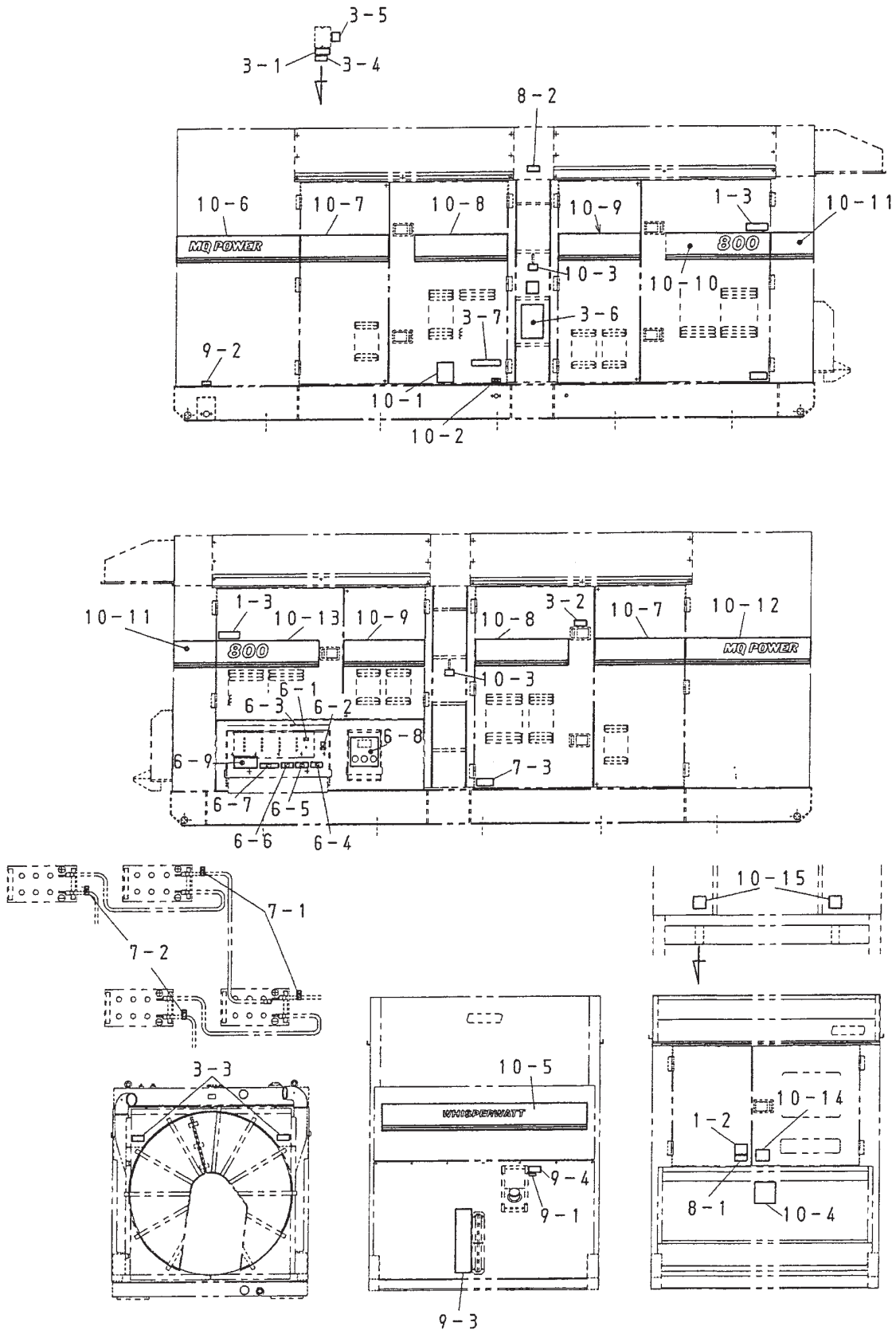

NAMEPLATE AND DECALS ASSY (CONTINUED)

<u>NO.</u>	<u>PART NO.</u>	<u>PART NAME</u>	<u>QTY.</u>	<u>REMARKS</u>
BATTERY GROUP				
71	0800689404	DECAL : +	2	S2090
72	0800689504	DECAL :	2	S2091
73	C9505300004	DECAL : CAUTION.....	1	C90530000
MUFFLER GROUP				
81	B9504200004	DECAL : WARNING ENGINE EXHAUST	1	B90420000
82	B9511100204	DECAL : CAUTION HOT SURFACES.....	1	B91110020
FUEL TANK GROUP				
91	1320620904	DECAL : DIESEL FUEL.....	1	S1756
92	6360620004	DECAL : FUEL DRAIN PLUG	1	S1883
93	0840607104	DECAL : FUEL GAUGE.....	1	S2365
94	B9504500004	DECAL : WARNING DIESEL FUEL	1	B90450000
BONNET GROUP				
101	0800615102	DECAL : CAUTION AGAINST OIL AND	1	S544A
102	1320610603	DECAL : WATER OIL	1	S1760
103	1320621504	DECAL : SUPPORT HOOK.....	2	S2257
104	0840625902	DECAL : MQ.....	1	S3057
105	C5561100703	STRIPE	1	
106	C5561101703	STRIPE	1	
107	C4561101404	STRIPE	2	
108	C5561101804	STRIPE	2	
109	C5561101304	STRIPE	2	
1010	C5561101603	STRIPE	1	
1011	C5561101104	STRIPE	2	
1012	C5561101504	STRIPE	1	
1013	C5561101204	STRIPE	1	
1014	A9504000014	DECAL : DANGER	1	A90400001
1015	C9511100804	DECAL : CAUTION.....	2	C91110080

NAMEPLATE AND DECALS ASSY. (CONTINUED)

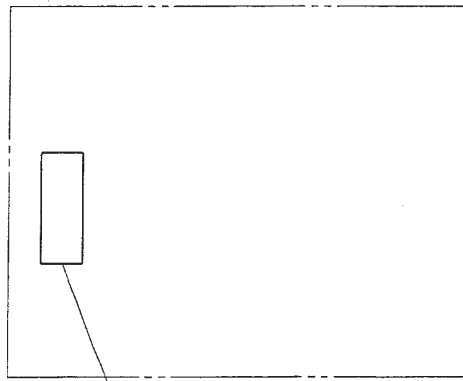

2-11

VIEW-Z

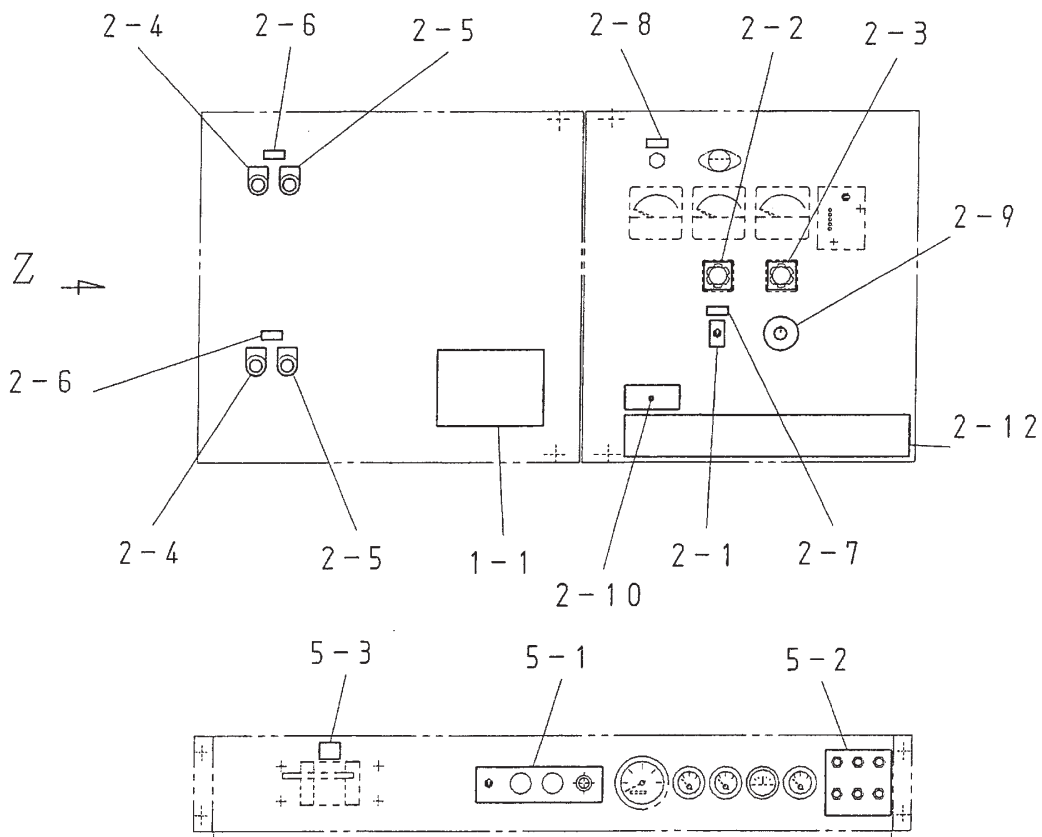

NAMEPLATE AND DECALS ASSY. (CONTINUED)

<u>NO.</u>	<u>PART NO.</u>	<u>PART NAME</u>	<u>QTY.</u>	<u>REMARKS</u>
11	C1552000403	DECAL : HANDLING PROCEDURES.....	1	C15200040
CONTROL PANEL & BOX GROUP				
21	0800520100	PLATE : ON OFF	1	AT 202
22	0800520904	PLATE : AMMETER CHANGE OVER SWITCH	1	N2438
23	0800520814	PLATE : VOLTMETER CHANGE OVER SWITCH.....	1	N2439
24	0800564004	PLATE : OFF	2	N3805
25	0800565004	PLATE : ON	2	N3806
26	0840624504	DECAL : CIRCUIT BREAKER.....	1	S3031
27	0840624604	DECAL : PANEL LIGHT SWITCH	1	S3032
28	0840624704	DECAL : PILOT LAMP.....	1	S3033
29	0840624804	DECAL : VOLTAGE REGULATOR	1	S3034
210	B9531100604	DECAL : WARNING ELECTRIC SHOCK HAZARD	2	B93110060
211	C5551000303	DECAL : SETTING FOR OUTPUT VOLTAGE.....	1	C55100030
212	C5561101003	DECAL : WHISPERWATT 800	1	C56110010
ENGINE OPERATING PANEL GROUP				
51	C5551001203	DECAL : OPERATING PANEL	1	C55100120
51A	0840647804	DECAL : EMERGENCY STOP	1	S4100
52	C5551001104	DECAL : WARNING LAMP	1	C55100110A
53	C0551000504	DECAL : BATTERY SWITCH	1	C05100050

TERMS AND CONDITIONS OF SALE — PARTS

PAYMENT TERMS

Terms of payment for parts are net 30 days.

FREIGHT POLICY

All parts orders will be shipped collect or prepaid with the charges added to the invoice. All shipments are F.O.B. point of origin. Multiquip's responsibility ceases when a signed manifest has been obtained from the carrier, and any claim for shortage or damage must be settled between the consignee and the carrier.

MINIMUM ORDER

The minimum charge for orders from Multiquip is \$15.00 net. Customers will be asked for instructions regarding handling of orders not meeting this requirement.

RETURNED GOODS POLICY

Return shipments will be accepted and credit will be allowed, subject to the following provisions:

1. A Returned Material Authorization must be approved by Multiquip prior to shipment.
2. To obtain a Return Material Authorization, a list must be provided to Multiquip Parts Sales that defines item numbers, quantities, and descriptions of the items to be returned.
 - a. The parts numbers and descriptions must match the current parts price list.
 - b. The list must be typed or computer generated.
 - c. The list must state the reason(s) for the return.
 - d. The list must reference the sales order(s) or invoice(s) under which the items were originally purchased.
 - e. The list must include the name and phone number of the person requesting the RMA.
3. A copy of the Return Material Authorization must accompany the return shipment.
4. Freight is at the sender's expense. All parts must be returned freight prepaid to Multiquip's designated receiving point.

5. Parts must be in new and resalable condition, in the original Multiquip package (if any), and with Multiquip part numbers clearly marked.
6. The following items are not returnable:
 - a. Obsolete parts. (If an item is in the price book and shows as being replaced by another item, it is obsolete.)
 - b. Any parts with a limited shelf life (such as gaskets, seals, "O" rings, and other rubber parts) that were purchased more than six months prior to the return date.
 - c. Any line item with an extended dealer net price of less than \$5.00.
 - d. Special order items.
 - e. Electrical components.
 - f. Paint, chemicals, and lubricants.
 - g. Decals and paper products.
 - h. Items purchased in kits.
7. The sender will be notified of any material received that is not acceptable.
8. Such material will be held for five working days from notification, pending instructions. If a reply is not received within five days, the material will be returned to the sender at his expense.
9. Credit on returned parts will be issued at dealer net price at time of the original purchase, less a 15% restocking charge.
10. In cases where an item is accepted, for which the original purchase document can not be determined, the price will be based on the list price that was effective twelve months prior to the RMA date.
11. Credit issued will be applied to future purchases only.

PRICING AND REBATES

Prices are subject to change without prior notice. Price changes are effective on a specific date and all orders received on or after that date will be billed at the revised price. Rebates for price declines and added charges for price increases will not be made for stock on hand at the time of any price change.

Multiquip reserves the right to quote and sell direct to Government agencies, and to Original Equipment Manufacturer accounts who use our products as integral parts of their own products.

SPECIAL EXPEDITING SERVICE

A \$35.00 surcharge will be added to the invoice for special handling including bus shipments, insured parcel post or in cases where Multiquip must personally deliver the parts to the carrier.

LIMITATIONS OF SELLER'S LIABILITY

Multiquip shall not be liable hereunder for damages in excess of the purchase price of the item with respect to which damages are claimed, and in no event shall Multiquip be liable for loss of profit or good will or for any other special, consequential or incidental damages.

LIMITATION OF WARRANTIES

No warranties, express or implied, are made in connection with the sale of parts or trade accessories nor as to any engine not manufactured by Multiquip. Such warranties made in connection with the sale of new, complete units are made exclusively by a statement of warranty packaged with such units, and Multiquip neither assumes nor authorizes any person to assume for it any other obligation or liability whatever in connection with the sale of its products. Apart from such written statement of warranty, there are no warranties, express, implied or statutory, which extend beyond the description of the products on the face hereof.

Effective: February 22, 2006

OPERATION AND PARTS MANUAL

HERE'S HOW TO GET HELP

PLEASE HAVE THE MODEL AND SERIAL
NUMBER ON-HAND WHEN CALLING

MULTIQUIP CORPORATE OFFICE

18910 Wilmington Ave Tel. (800) 421-1244
Carson, CA 90746 Fax (800) 537-3927
Contact: mq@multiquip.com
Web: www.multiquip.com

MQ Power

1800 Water Ridge Rd. Tel. (800) 883-2551
Suite 500/600 Fax (972) 315-1847
Lewisville, TX 75057
Contact: mqpower@multiquip.com
Web: www.mqpower.com

MQ Parts Department

800-427-1244 Fax: 800-672-7877
310-537-3700 Fax: 310-637-3284

Service/Tech Support/Warranty

800-835-2551 Fax: 310-638-8046

© COPYRIGHT 2009, MULTIQUIP INC.

MQ Power and the MQ Power logo are registered trademarks of Multiquip Inc. and may not be used, reproduced, or altered without written permission. All other trademarks are the property of their respective owners and used with permission.

This manual MUST accompany the equipment at all times. This manual is considered a permanent part of the equipment and should remain with the unit if resold.

The information and specifications included in this publication were in effect at the time of approval for printing. Illustrations, descriptions, references and technical data contained in this manual are for guidance only and may not be considered as binding. Multiquip Inc. reserves the right to discontinue or change specifications, design or the information published in this publication at any time without notice and without incurring any obligations.

Further, MQ Power disclaims any warranties or guaranties, expressed or implied, with regards to the information contained in this manual.

Your Local Dealer is:

Manufactured for
Multiquip Inc.
by
DENYO CO., LTD, JAPAN[®]

