

MQ MULTIQUIP **DuoScreed™**

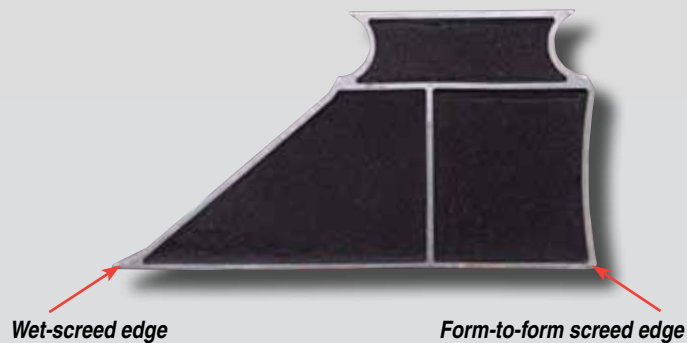

**Form-to-form
and wet screeding
with one machine**





DuoScreed

MultiQuip's DuoScreed utilizes a unique blade profile that enables one person to strike-off concrete floors. The screed's vibratory action embeds aggregate and reduces air voids, producing a strong, dense slab, while eliminating the strenuous, time-consuming labor of manual screeding.

The DuoScreed is ideal for a wide range of applications. Unlike competitive designs (which require different blades for each application), the DuoScreed uses a unique reversing blade. One side is used for standard form-to-form screeding, and the other side is for wet screeding.

- **Flexible drive shaft** requires no maintenance.
- **Fingertip throttle control** adjusts vibrator speed.
- **Blade widths available in sizes up to 20 feet long.**
- **Lightweight blade construction** — one-piece extruded aluminum, less than two pounds per linear foot.
- **Easy to use** — highly maneuverable around pipes or obstructions.
- **Unique reversing blade** — power unit is easily rotated 180 degrees to allow form-to-form or wet screeding.
- **Adjustable control handle** — customize for operator height and comfort.
- **Portable design** — the blade is quickly removed without tools; handles fold for storage.
- **Honda powered** — 1.5 HP four-stroke engine

Specifications

Model.....	DSGPULW
Blade widths (ft.)	6, 8, 10, 12, 14, 16, 18*, 20*
Blade construction.....	Aluminum
Engine	Honda GX-35SAT
HP (kW).....	1.3 (1.0)
Drive system.....	Flexible shaft
Power Unit weight.....	32 lb.
* 18 and 20ft. blade widths require two power units.	

* Engine power ratings are calculated by the individual engine manufacturer and the rating method may vary among engine manufacturers. MultiQuip Inc. and its subsidiary companies makes no claim, representation or warranty as to the power rating of the engine on this equipment and disclaims any responsibility or liability of any kind whatsoever with respect to the accuracy of the engine power rating. Users are advised to consult the engine manufacturer's owners manual and its website for specific information regarding the engine power rating.

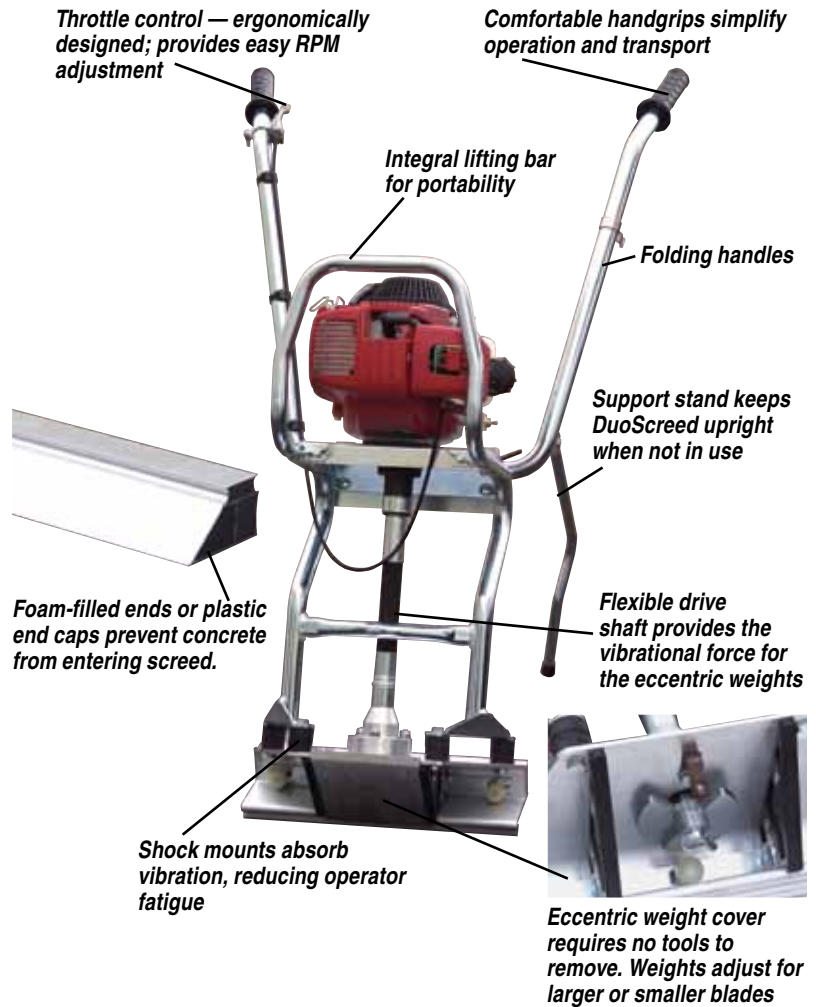

© COPYRIGHT 2011, MULTIQIP INC.

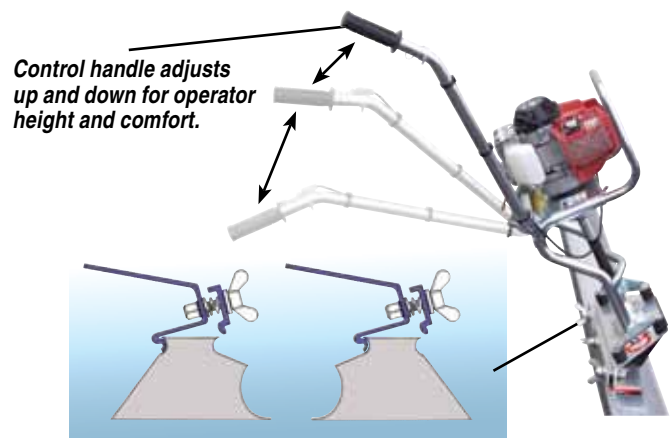

Control handle adjusts up and down for operator height and comfort.

Blade reverses in seconds without tools.



MULTIQIP INC.
 POST OFFICE BOX 6254
 CARSON, CA 90749
 310-537-3700 • 800-421-1244
 FAX: 310-537-3927
 E-MAIL: mq@multiquip.com
 www.multiquip.com