



Mandatory Bulletin No. RR20070815 Rev A
Subject: Fuel Shutoff Solenoid Failure
Models: P35, P48 and P54
Product Group: Roller
Date: 11/29/07

INFORMATIONAL BULLETIN

Group: RR

FOR INFORMATION ONLY

Series/Parts Affected:

Machines Affected:

P35K and P48K — ALL
P54K Series — S/N 483652 and below

SERVICE INFORMATION

Problem:

- Shutoff solenoid fails.
- Defective engine shutdown relay (P35/P48).

Remedy:

- Properly align or replace shutoff solenoid.
- If necessary, replace defective engine shutdown relay (P35 and P48 models only).

PARTS INFORMATION

Item	Quantity	Part #	Description	Remarks
P35/P48				
1	1	1547160010	SOLENOID, STOP	P35/P48 Only
2	1	1547160162	LEVER, STOP, ARM	P35/P48 Only
3	1	1733160150	LEVER, STOP, ROD	P35/P48 Only
4	1	KUT007031410	RELAY, SHUTDOWN	P35/P48 Only
P54				
5	1	KITSOLP54	KIT, SOLENOID P54	INCLUDES ITEMS 6 THRU 18
6	1		SOLENOID, 12 VDC	P54 ONLY
7	1		SUPPORT BRACKET	P54 ONLY
8	4		BOLT 1/4" X 3/4" NC	P54 ONLY
9	4		WASHER, FLAT 1/4"	P54 ONLY
10	1		WASHER, STAR 1/4"	P54 ONLY
11	4		NUT, NYLOC 1/4"	P54 ONLY
12	1		WASHER, STAR 12 MM	P54 ONLY
13	1		WASHER, LOCK 12 MM	P54 ONLY
14	2		BOLT, 12 MM X 1.25, SPECIAL THREAD	P54 ONLY
15	1		WIRE, GREEN 6.5"	P54 ONLY
16	1		WIRE, BLACK 6.5"	P54 ONLY
17	5		TIE WRAP 7.5"	P54 ONLY

Shutoff Solenoid Operation

The main function of the shutoff solenoid is to stop the engine after the ignition switch has been placed in the **OFF** position. When the engine is in use (running) the shutoff solenoid is inactive (**OFF**), meaning it has no influence on the engine.

When the ignition switch is placed in the **OFF** position the shutoff solenoid becomes active (**ON**). The **OFF** position of the ignition switch activates the engine stop relay which in turn energizes the shutoff solenoid. The magnetic coil of the solenoid draws the piston inward and moves with the aid of the connecting rod and rocker arms. This condition will cause the engine to stop.

After approximately 8~10 seconds the piston will return to the inactive (**OFF**) position. See Figures 1A and 1B below for a graphical representation of shutoff solenoid operation.

INSPECTION (P35/P48 ONLY)

1. Lift engine hood and locate engine shutoff solenoid (Figure 1).
2. Start engine and let run for a few seconds. After engine has stopped (wait approximately 8~10 seconds), verify that engine rocker arm does not make contact with engine stop tab. See Figures 1A and 1B below. If engine rocker arm is striking stop tab corrective action needs to be taken. Shutoff solenoid needs to be readjusted. If your machine works as indicated by Figure 1B, then you can assume your machine is functioning correctly and no corrective action is required.

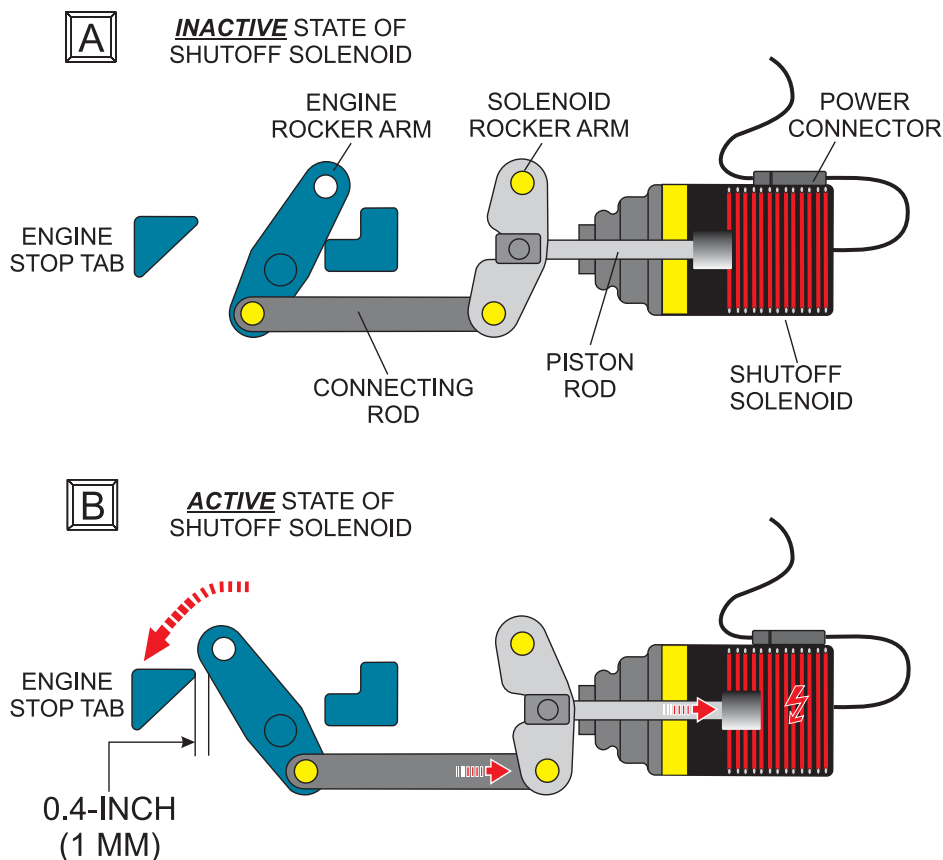

Figure 1. Shutoff Solenoid Active State

INSTALLATION INSTRUCTIONS

WORK SAFELY!

Only a qualified service technician with proper training should perform this installation. Follow all shop safety regulations when working on the machine.

Required Tools/Materials

- 3/8 Ratchet
- 10 mm drive socket
- 12 mm drive socket
- 13 mm drive socket
- Wire Cutters

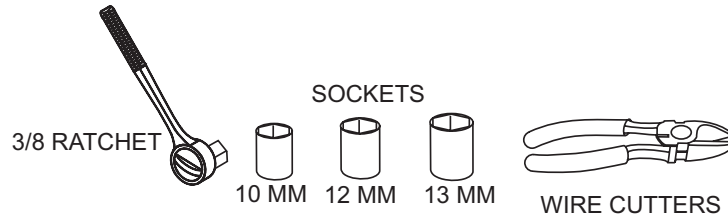

If applicable, please make sure all parts are accounted for.

Safety Procedures

Perform the following before attempting any work on the machine:

1. Place the roller on level secure ground that is free of dirt and debris.
2. Follow all shop safety guidelines when working on the roller.
3. Wear safety glasses, steel toed boots and any other safety protection that might be required for inspection or installation.

Shutoff Solenoid Alignment (P35/P48)

Reference Figures 2A thru 2C

When aligning the shutoff solenoid, look for the following:

- Placement of solenoid support bracket on engine is incorrect, allows rocker arm to contact the fixed stop. This condition may damage connecting rod and allow solenoid to remain activated and eventually burn.
- Connecting rod which transmits pulling tension is bent or not parallel to the moving direction.
- Maximum travel distance of piston (solenoid energized) is not reached due to incorrect alignment or position of shutoff solenoid.

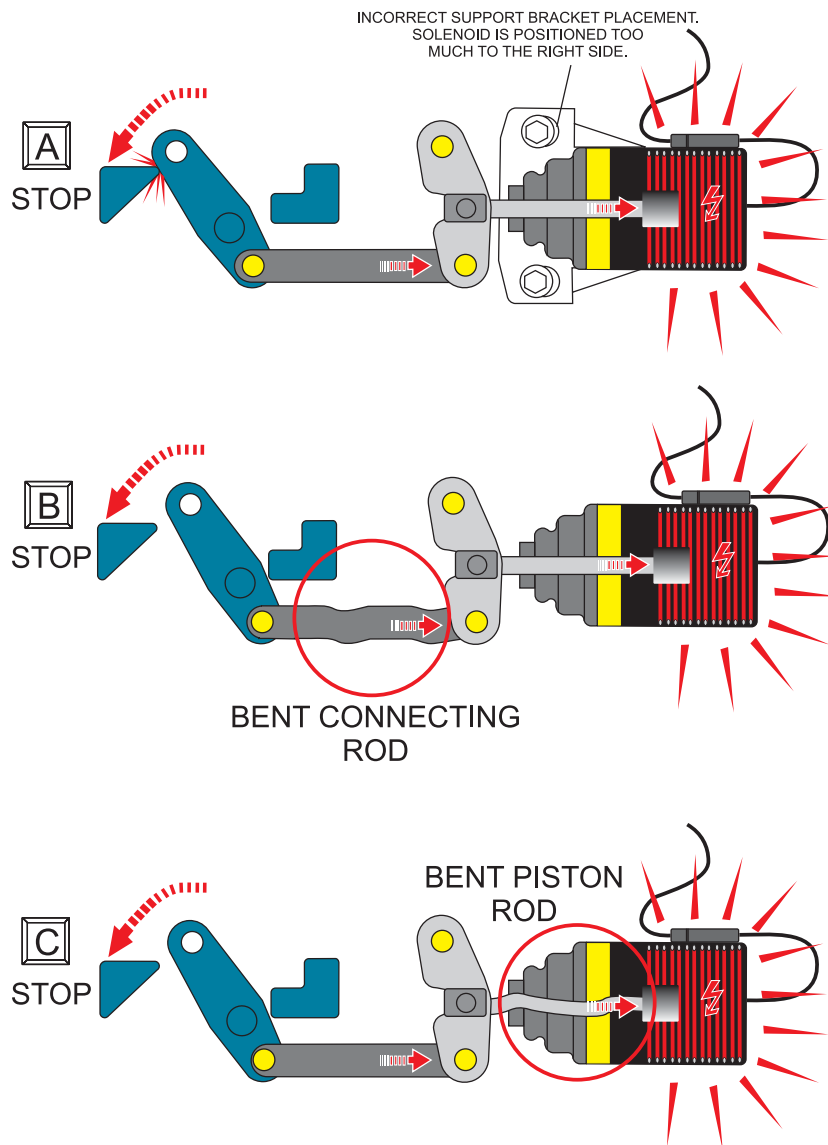

Figure 2. Shutoff Solenoid Malfunction

Shutoff Solenoid Replacement (P35/P48 Only)

If your unit exhibits the symptoms listed below it can be assumed that either the shutoff solenoid and/ or engine shutdown relay need corrective action.

- After stopping engine, engine will not restart.
- Before engine stops, continued fluctuations in speed and stuttering occur.

If the shutoff solenoid is found to be defective, perform the following:

1. Lift engine hood and disconnect negative battery cable from battery.
2. Disconnect power cable (Figure 3) from defective shutoff solenoid. Cut any tie-wraps that may be securing power cable.
3. Using a 3/8-inch ratchet with a 12 mm socket, remove the bolts (2) that secure the shutoff solenoid (Figure 3) to the engine. Remove defective shutoff solenoid from machine.

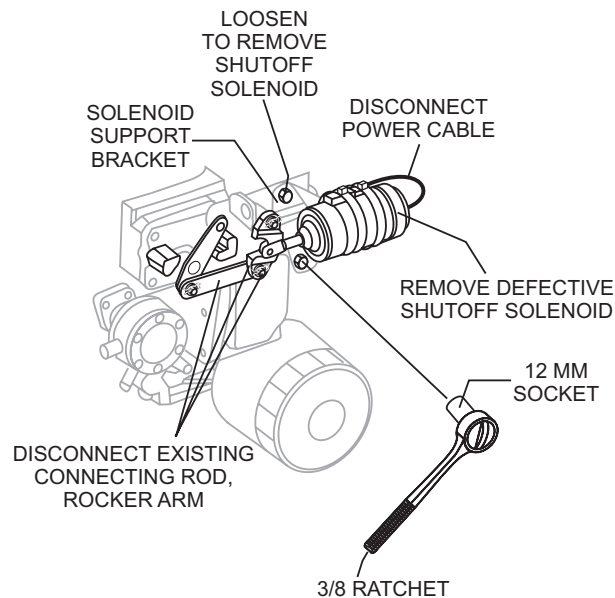

Figure 3. Shutoff Solenoid Removal

4. Using the bolts (2) that were removed in step 3, place new shutoff solenoid onto engine. Tighten mounting bolts securely.
5. Reconnect power cable to shutoff solenoid. Use tie-wraps as necessary.
6. Reconnect battery.
7. Adjust shutoff solenoid support bracket so that it is positioned parallel to the moving direction.
8. Place throttle lever in the ***idle*** position and start engine. Let engine run for a few seconds.
9. Stop engine (wait approximately 8~10 seconds), verify that engine rocker arm does not make contact with engine stop tab. At maximum deflection (travel) the rocker arm ***should not come in contact with the engine stop tab***. Distance between rocker arm and engine stop tab should be approximately .04-inches (1mm).
10. Repeat steps 8 and 9 with throttle lever in the ***full*** (high RPM) position.

Engine Stop Relay Replacement (P35 and P48 Rollers Only)

If the engine stop relay is found to be defective, perform the following:

1. Lift engine hood and disconnect negative battery cable from battery.
2. Using a 3/8-inch ratchet with a 10 mm socket, remove 4 bolts securing console cover panel (Figure 4). Set console cover panel aside.



Figure 4. Console Panel Removal

3. Locate engine stop relay (Figure 5). Disconnect wiring connector at bottom of relay.



Figure 5. Engine Stop Relay Removal/Installation

4. Using a 3/8-inch ratchet with a 13 mm socket remove the bolt that secures the engine stop relay to the frame. Remove engine stop relay.
5. Install and secure new relay onto machine frame. Insert wiring connector back into relay.
6. Reconnect battery.

P54 Rollers Only (S/N 483652 and below)

Ramax has made improvements to the OEM solenoid to ensure positive engine shutdown at any RPM. This improvement will require the removal of the OEM solenoid and replacement with solenoid P/N KITSOLP54.

Shutoff Solenoid Replacement (P54 Only, Reference Figure 6)

Perform the following for replacement of shutoff solenoid:

1. Lift engine hood and disconnect negative battery cable from battery.
2. Disconnect power cable (Figure 6A) from shutoff solenoid.

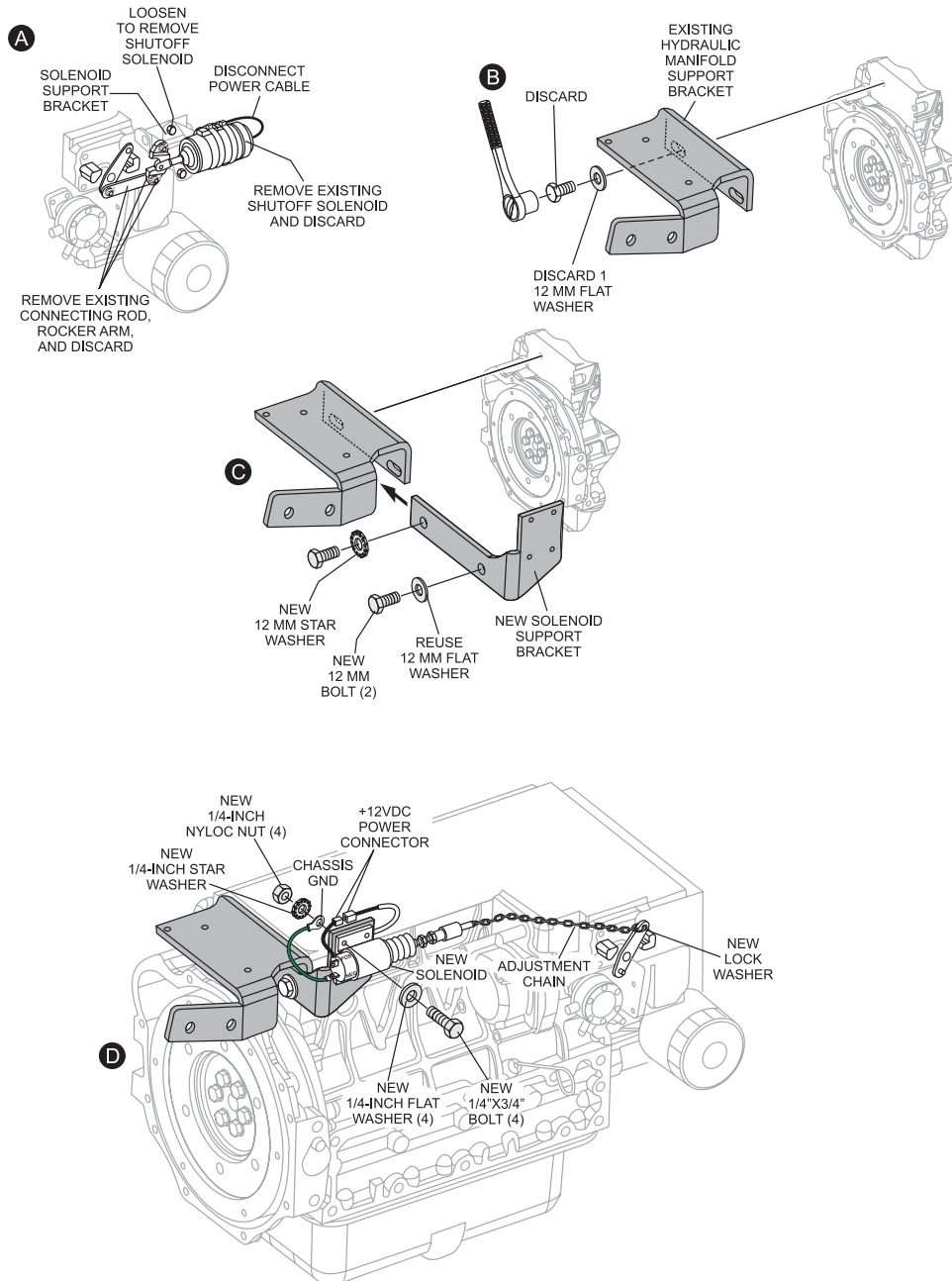

Figure 6. Solenoid Replacement (P54 Only)

3. Using a 3/8-inch ratchet with a 12 mm socket remove the bolts (2) that secure the **solenoid support bracket** to the engine (Figure 6A).
4. Discard solenoid mounting bracket, shutoff solenoid and associated hardware.
5. Using a 3/8-inch ratchet with a 12 mm socket, remove the bolts (2) that secure the **hydraulic manifold support bracket** to the engine (Figure 6B). Discard mounting bolts and one 12 mm flat washer. Retain other flat washer.
6. Install new solenoid support bracket in front of hydraulic manifold support bracket as shown in Figure 6C. Use new 12 mm bolts (2) along with existing 12 mm flat washer and new 12 mm star washer to secure both support brackets onto engine.
7. Place heavy duty shutoff solenoid onto solenoid support bracket as shown in Figure 6D. Use new 1/4" X 3/4" mm bolts (4) along with 1/4-inch flat washers (4), 1/4-inch star washer (1) and 1/4-inch nyloc nuts (4) to secure shutoff solenoid to support bracket. Tighten all nuts and bolts securely. **NOTE:** place ground terminal ring (green 6.5-inch wire) onto support bracket before tightening. Connect the other end of this wire to the **negative terminal** on the solenoid
8. Connect shutoff solenoid adjustment chain (Figure 6D) to engine rocker arm. Use lock washer (attached to chain) to secure chain to engine rocker arm. Adjust chain so that a little slack is present when the engine rocker arm is in the inactive state.
9. Connect one end of the new black +12VDC power wire (6.5-inch wire) to the engine solenoid power connector (Figure 6D). Connect the other end of this wire to the **positive terminal** on the shutdown solenoid.
10. Use tie wrap where applicable.
11. Reconnect battery.

Shutoff Solenoid Adjustment (P54 Only)

1. Place throttle lever in the idle position.
2. Place ignition key into ignition switch and start engine. Let engine run for a few seconds. Stop engine. After engine has stopped (wait approximately 8~10 seconds), verify that engine rocker arm does not make contact with engine stop tab.
3. If engine rocker arm is striking engine stop tab, solenoid needs to be readjusted. Continue using steps 1 and 2 to adjust solenoid until engine rocker arm has the correct clearance from the engine stop tab. Reference Figure 1B.
4. Repeat steps 2 and 3 with the throttle lever in the **full** (high RPM) position.
5. Once the correct solenoid travel position has been obtained, turn the jam nut (Figure 6D) against the swivel adapter, to lock the position in place

If you have any questions regarding the procedure described in this informational bulletin, please contact the Multiquip technical support department at 800-478-1244 for assistance!