



Service Bulletin No. VR20091204
Subject: Check Valve/Steering Pressure
Model: RX1510-C-I-CI
Product Group: Trench Roller
Date: December 04, 2009

SERVICE BULLETIN

Group: VR

THIS SERVICE BULLETIN IS MANDATORY!

Series/Parts Affected:
All Units

SERVICE INFORMATION	
MANDATORY UPDATE: FAILURE TO FOLLOW INSTRUCTIONS MAY LEAD TO INJURY OR DEATH AND CAUSE SEVERE UNIT DAMAGE!	
Problem 1:	
<ul style="list-style-type: none">Hydraulic brake pressure for both front and rear drive motors may not be adequate in severe angles. To maintain proper hydraulic brake pressure, new check valves must be installed.This condition may cause the drive motor brake to disengage and <i>may lead to injury or death and severe unit damage!</i>	
Solution: Install new check valves.	
Problem 2:	
<ul style="list-style-type: none">Hydraulic steering relief pressure may be set incorrectly.This condition may produce an increased load on the engine.	
Solution: Reset steering pressure.	

PARTS INFORMATION			
Quantity	Part #	Description	Remarks
2	3-48174	Check Valve	Problem 1

INSTRUCTIONS

WORK SAFELY!

This procedure should be performed only by a **qualified service technician** following safe and approved workshop techniques.

Required Tools

- 24 mm Wrench
- 6 mm Allen Wrench

Safety Procedures

Perform the following before attempting installation:

1. Following all safety shop rules and regulations when performing this installation.
2. Place the machine on level secure ground that is free of dirt and debris.

Check Valve Installation Procedure

1. Remove ignition key.

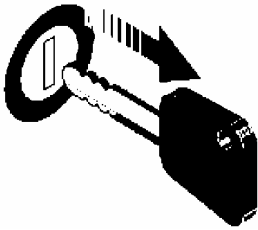

Figure 1. Ignition Key Removal

2. Lock emergency stop bumper (Figure 2).

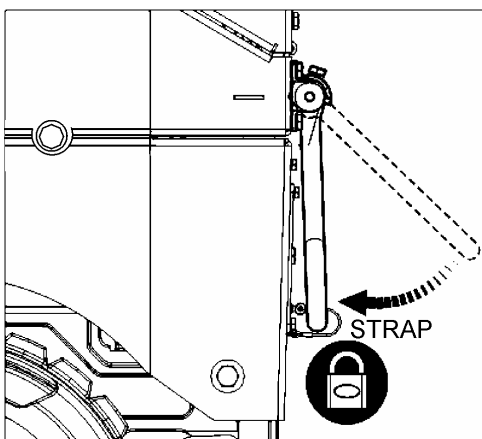

Figure 2. Locking Emergency Stop Bumper

3. Lock the articulation joint (Figure 3).

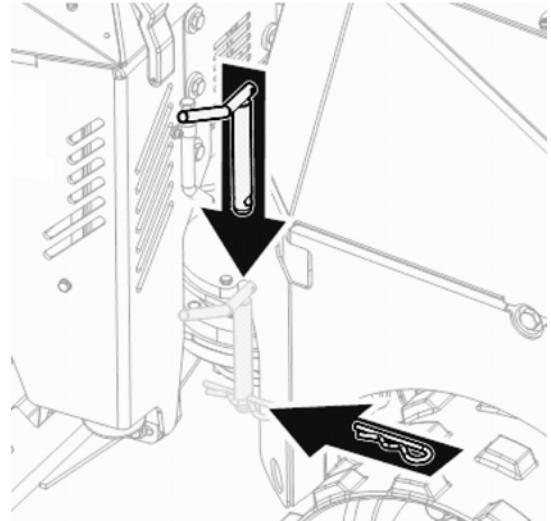

Figure 3. Locking Articulation Joint

4. Place chock blocks (Figure 4) underneath each drum to prevent rolling.

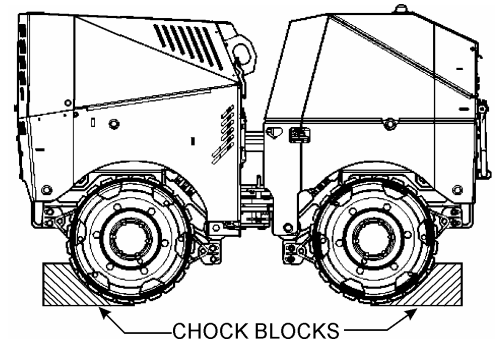

Figure 4. Chock Block Placement

5. Reference Figure 5 for hose and fitting locations.

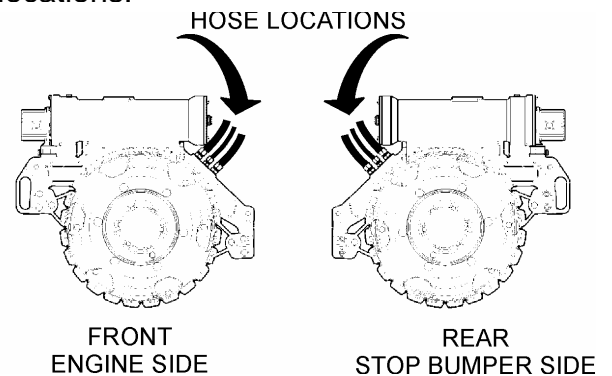

Figure 5. Hose/Fitting Locations

- At rear stop bumper side of roller, remove hose **A** as shown in Figure 6.

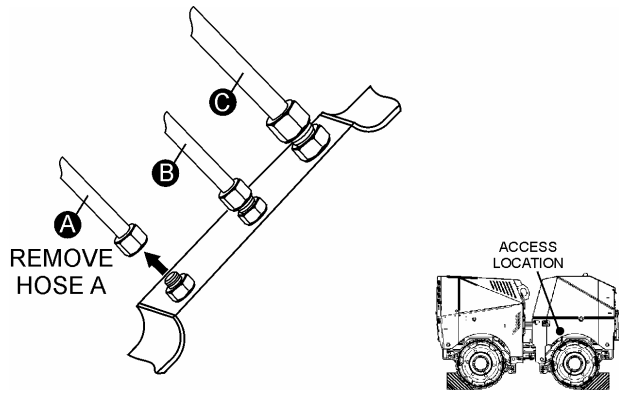

Figure 6. Hydraulic Hose A Removal (Rear Stop Bumper Side)

- Remove fitting as shown in Figure 7. Removal of this fitting will provide easier access when removing hose B and its associated fitting. Place this fitting in a safe place where it will not get lost. It will be used later.

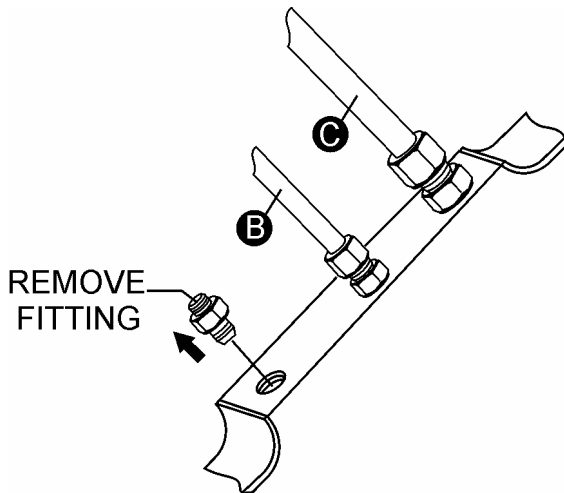

Figure 7. Fitting Removal (Hose A)

- Remove hose **B** as shown in Figure 7.

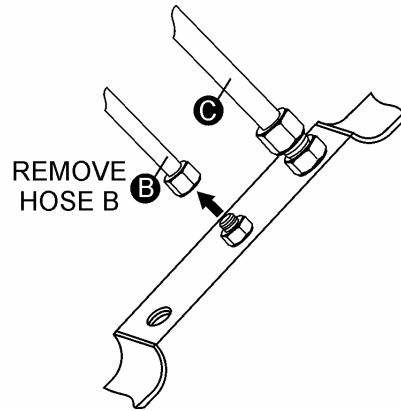

Figure 8. Hose B Removal

- Remove existing fitting (P/N 57502) as shown in Figure 8. Discard fitting as it will no longer be used.

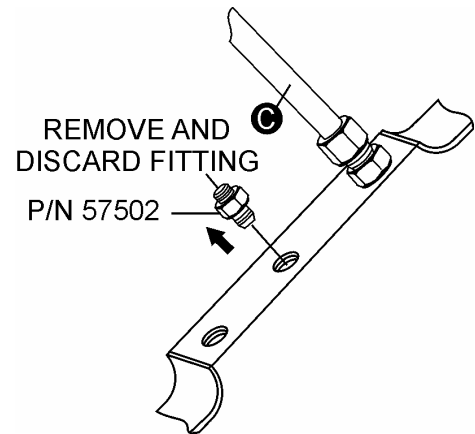

Figure 9. Fitting Removal (Hose B)

- Install new fitting P/N 3-48174 into **port B** as shown in Figure 10.

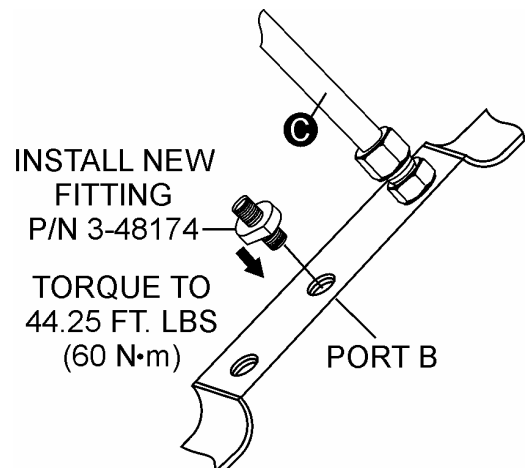

Figure 10. New Fitting Installation

11. Reinstall hose **B** as shown in Figure 11.

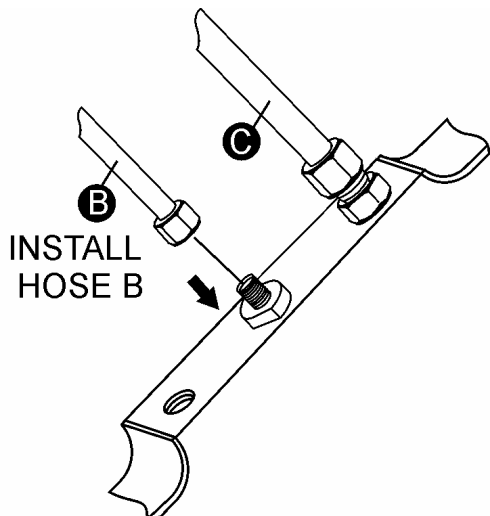

Figure 11. Re-Connect Hose B

13. Reinstall hose **A** as shown in Figure 13.

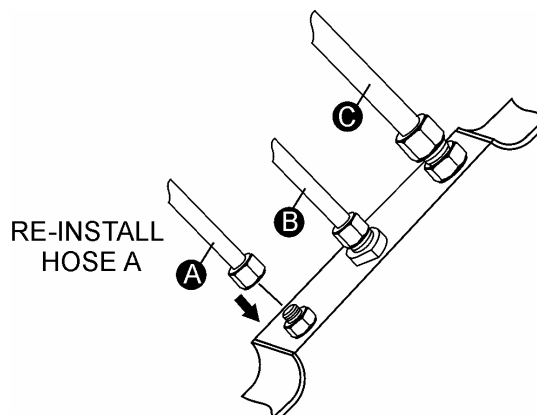

Figure 13. Re-Connect Hose A

12. Reinstall fitting removed in step 7 into port **A** as shown in Figure 12.

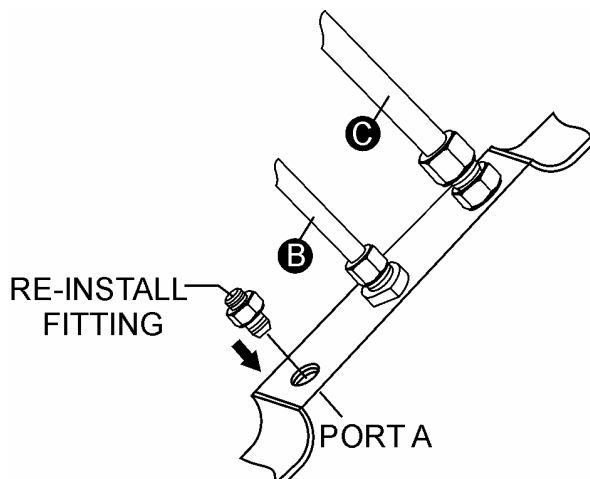

Figure 12. Port A Fitting Installation

14. Using same installation procedure, install second check valve at port **B**, engine end of roller. Remove hose **A** (engine side) as referenced in Figure 14 to make installation easier.

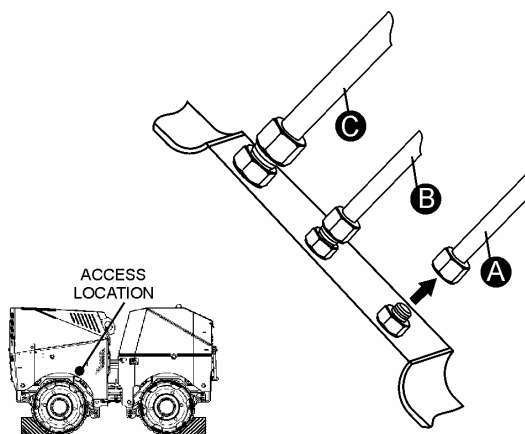

Figure 14. Hydraulic Hose A Removal Engine Side

Hydraulic Steering Pressure Calibration Procedure

1. Lift hood compartment at emergency stop bumper end of machine.
2. Locate manifold valve block (Figure 15).
3. At manifold valve block, remove black plastic cap covering hydraulic steering pressure adjustment screw.
4. Using a 24 mm wrench, loosen jam nut.
5. Insert 6 mm allen-wrench into hydraulic steering pressure adjustment screw.
6. Rotate adjustment screw counter-clockwise 1-1/2 turn.
7. Remove allen-wrench, and tighten jam nut.
8. Re-install black plastic cap.
9. Close hood.

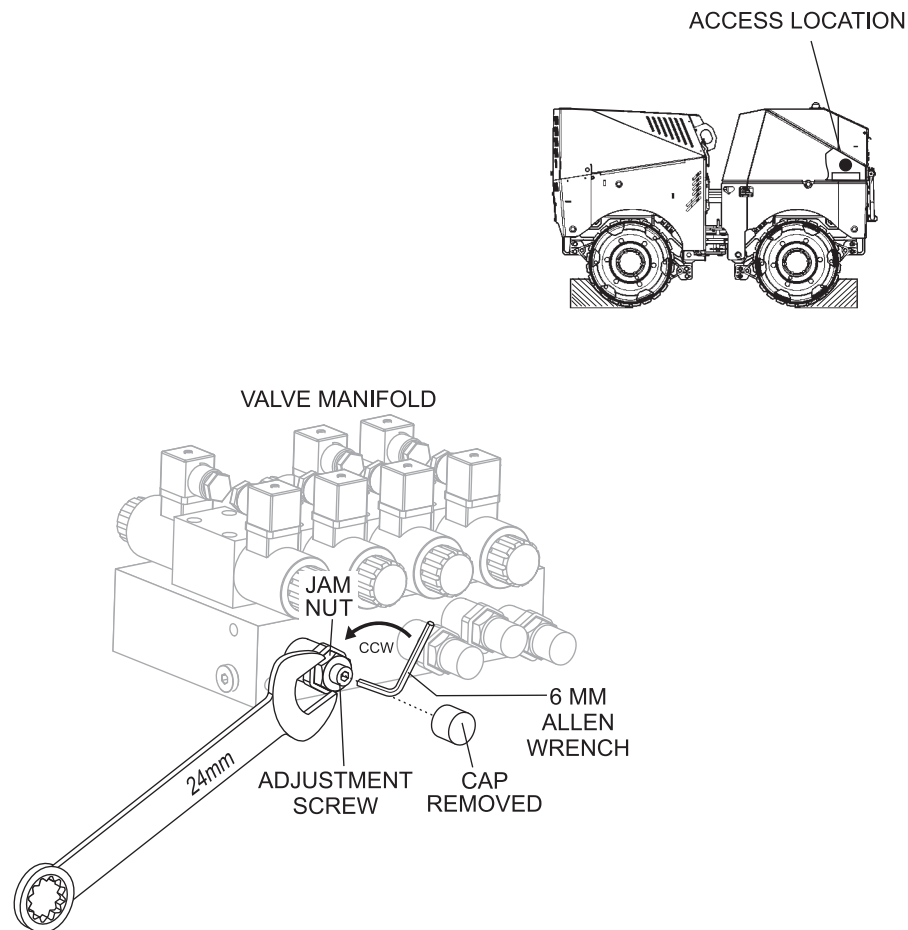

Figure 15. Hydraulic Steering Adjustment

If you have any questions regarding either of the procedures described above, contact the Multiquip technical support department at 800-478-1244 for assistance!

WARRANTY INFORMATION

Campaign: Reference No. 20091204

Multiquip will reimburse up to .75 hours of labor per machine for this repair.

Contact the Multiquip warranty department for claim number and warranty form.

Multiquip Warranty Department

800-421-1244

Chris Fairchild – Extension 1279

Wendy Sanchez - Extension 1322