

OPERATION AND PARTS MANUAL



ULTRA-SILENT™ SERIES MODEL DCA-70USI 60 Hz GENERATOR

PARTS LIST NO. M2900000314

Revision #0 (01/04/06)

**THIS MANUAL MUST ACCOMPANY
THE EQUIPMENT AT ALL TIMES.**



WARNING



CALIFORNIA — Proposition 65 Warning

Diesel engine exhaust and some of its constituents are known to the State of California to cause cancer, birth defects and other reproductive harm.

HERE'S HOW TO GET HELP

PLEASE HAVE THE MODEL AND SERIAL
NUMBER *ON-HAND* WHEN CALLING

MQ POWER CORPORATE OFFICE

18910 Wilmington Ave. 800-421-1244
Carson, CA 90746 FAX: 310-632-2656
Email: mqpower@multiquip.com
Internet: www.mqpower.com

PARTS DEPARTMENT

800-427-1244 FAX: 800-672-7877
310-537-3700 FAX: 310-637-3284

SERVICE DEPARTMENT

800-835-2551 FAX: 310-638-8046
310-537-3700

TECHNICAL ASSISTANCE

800-835-2551 FAX: 310-638-8046

WARRANTY DEPARTMENT

800-835-2551, EXT. 279 FAX: 310-638-8046
310-537-3700, EXT. 279

© COPYRIGHT 2005, MULTIQUIP INC.

MQ Power Inc, Ultra-Silent series, and the MQ Power logo are registered trademarks of Multiquip Inc. and may not be used, reproduced, or altered without written permission. All other trademarks are the property of their respective owners and used with permission.

This manual **MUST** accompany the equipment at all times. This manual is considered a permanent part of the equipment and should remain with the unit if resold.

The information and specifications included in this publication were in effect at the time of approval for printing. Illustrations are based on the *DCA-70USI (60 Hz) Ultra Silent Generator*. Multiquip Inc. reserves the right to discontinue or change specifications, design or the information published in this publication at any time without notice and without incurring any obligations.

To find the latest revision of this
publication, visit our website at:
www.mqpower.com



**MQ POWER DCA-70USI(60HZ)
ULTRA-SILENT GENERATOR**

California Proposition 65 Warning 2
 Here's How To Get Help 3
 Table Of Contents 4
 Parts Ordering Procedures 5
 Specifications 6
 Dimensions (Top, Side, Front) 7
 Safety Message Alert Symbols 8-9
 Rules for Safe Operation 10-13
 Generator Decals 14-15
 Installation 16-17
 General Information 18
 Major Components 19
 Generator Control Panel 21
 Engine Operating Panel 22-23
 Output Terminal Panel Familiarization 24-26
 Load Application 27
 Generator Outputs 28
 Gauge Reading 29
 Output Terminal Panel Connections 30-31
 Pre-Setup 32-35
 Generator Start-up Procedure (Manual) 36-37
 Generator Start-up Procedure (Auto Mode) 38
 Generator Shut-Down Procedure 38
 Maintenance (Engine) 39-40
 Maintenance (Trailer) 41-44
 Trailer Wiring Diagram 45
 Generator Wiring Diagram 46
 Engine Wiring Diagram 47
 Generator Troubleshooting 48
 Engine Controller Troubleshooting 49
 Explanation of Code in Remarks Column 50
 Suggested Spare Parts 51

ISUZU FF- 4BG1T ENGINE

Generator Assembly 52-53
 Control Box Assembly 54-57
 Engine and Radiator Assembly 58-61
 Output Terminal Assembly 62-63
 Battery Assembly 64-65
 Muffler Assembly 66-67
 Fuel Tank Assembly 68-69
 Enclosure #1 Assembly 70-73
 Enclosure #2 Assembly 74-75
 Rubber Seals Assembly 76-77
 Nameplate and Decals 78-79
 Terms and Condition of Sale — Parts 80

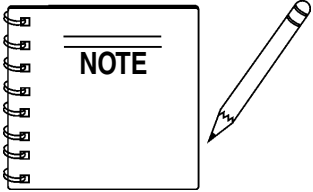

Specification and part number are subject to change without notice.

PARTS ORDERING PROCEDURES

When ordering parts, please supply the following information:

- Dealer account number
- Dealer name and address
- Shipping address (if different than billing address)
- Return fax number
- Applicable model number
- Quantity, part number and description of each part
- Specify preferred method of shipment:
 - ✓ FedEx or UPS Ground
 - ✓ FedEx or UPS Second Day or Third Day
 - ✓ FedEx or UPS Next Day
 - ✓ Federal Express Priority One
 - ✓ DHL
 - ✓ Truck

Note: Unless otherwise indicated by customer, all orders are treated as "Standard Orders", and will ship within 24 hours. We will make every effort to ship "Air Shipments" the same day that the order is received, if prior to 2PM west coast time. "Stock Orders" must be so noted on fax or web forms.



Here's how to get help...

Please have the model and serial number on hand when calling.

MQ POWER CORPORATE OFFICE

18910 Wilmington Ave. 800-421-1244
 Carson, CA 90746 FAX: 310-632-2656
 Email: mqpower@multiquip.com
 Internet: www.mqpower.com

PARTS DEPARTMENT

800-427-1244 FAX: 800-672-7877
 310-537-3700 FAX: 310-637-3284

SERVICE DEPARTMENT

800-835-2551 FAX: 310-638-8046
 310-537-3700

TECHNICAL ASSISTANCE

800-835-2551 FAX: 310-638-8046

WARRANTY DEPARTMENT

800-835-2551, EXT. 279 FAX: 310-638-8046
 310-537-3700, EXT. 279

Place Your Parts Order Via Web or Fax For Even More Savings!

(Domestic USA Dealers Only)

Extra Discounts!

All parts orders which include complete part numbers and are received by our automated web parts order system, or by fax qualify for the following extra discounts:

Ordered via	Standard orders	Stock orders (\$750 list and above)
Fax	3%	10%
Web	5%	10%

Special freight allowances when you order 10 or more line items via Web or Fax! **

FedEx Ground Service **at no charge for freight**

No other allowances on freight shipped by any other carrier.

****Common nuts, bolts and washers (all items under \$1.00 list price) do not count towards the 10+ line items.**

NOTE: DISCOUNTS ARE SUBJECT TO CHANGE



MQPOWER
 A Division of Multiquip Inc.
 POST OFFICE BOX 6254
 CARSON, CA 90749
 310-537-3700 • 800-421-1244
 FAX: 310-632-2656
 E-MAIL: mqpower@multiquip.com
 INTERNET: www.mqpower.com

Direct TOLL-FREE access to our Parts Department:

Toll-free nationwide — 800-427-1244

Toll-free FAX — 800-6-PARTS-7 (800/672-7877)

DCA-70USI (60 Hz) — SPECIFICATIONS

Table 1. Generator Specifications

Model	DCA-70USI	
Type	Revolving field, self ventilated, open protected type synchronous generator	
Armature Connection	Star with Neutral	Zig Zag
Phase	3	Single
Standby Output	73.5 KVA (58.8 KW)	42 KW
Prime Output	70 KVA (56 KW)	40 Kw
Voltage	240V or 480V	240/120
Frequency	60 Hz	
Speed	1800 rpm	
Power Factor	0.8	1
Aux. AC Power	Single Phase, 60 Hz	
Voltage	120 V	
Output	4.8 KW (2.4 KW x 2)	

Table 2. Engine Specifications

Model	ISUZU FF- 4BG1T
Type	4 cycle, water-cooled, direct injection, turbo-charged
No. of Cylinders	4 cylinders
Bore x Stroke	4.13 in. x 4.92 in. (105 mm x 125 mm)
Displacement	264 cu. in. (4,329 cc)
Starting	Electric 12VDC
Coolant Capacity	3.80 gal. (14.4 liters)
Lube Oil Capacity	3.49 gal. (13.2 liters)
Fuel Type	#2 Diesel Fuel
Fuel Tank Capacity	103 gal. (390 liters)
Fuel Consumption	4.31 gal. (13.0 L)/hr at full load
Battery	27(CCA O F 700A) x 1

DCA-70USI (60 Hz) — DIMENSIONS (TOP, SIDE AND FRONT)

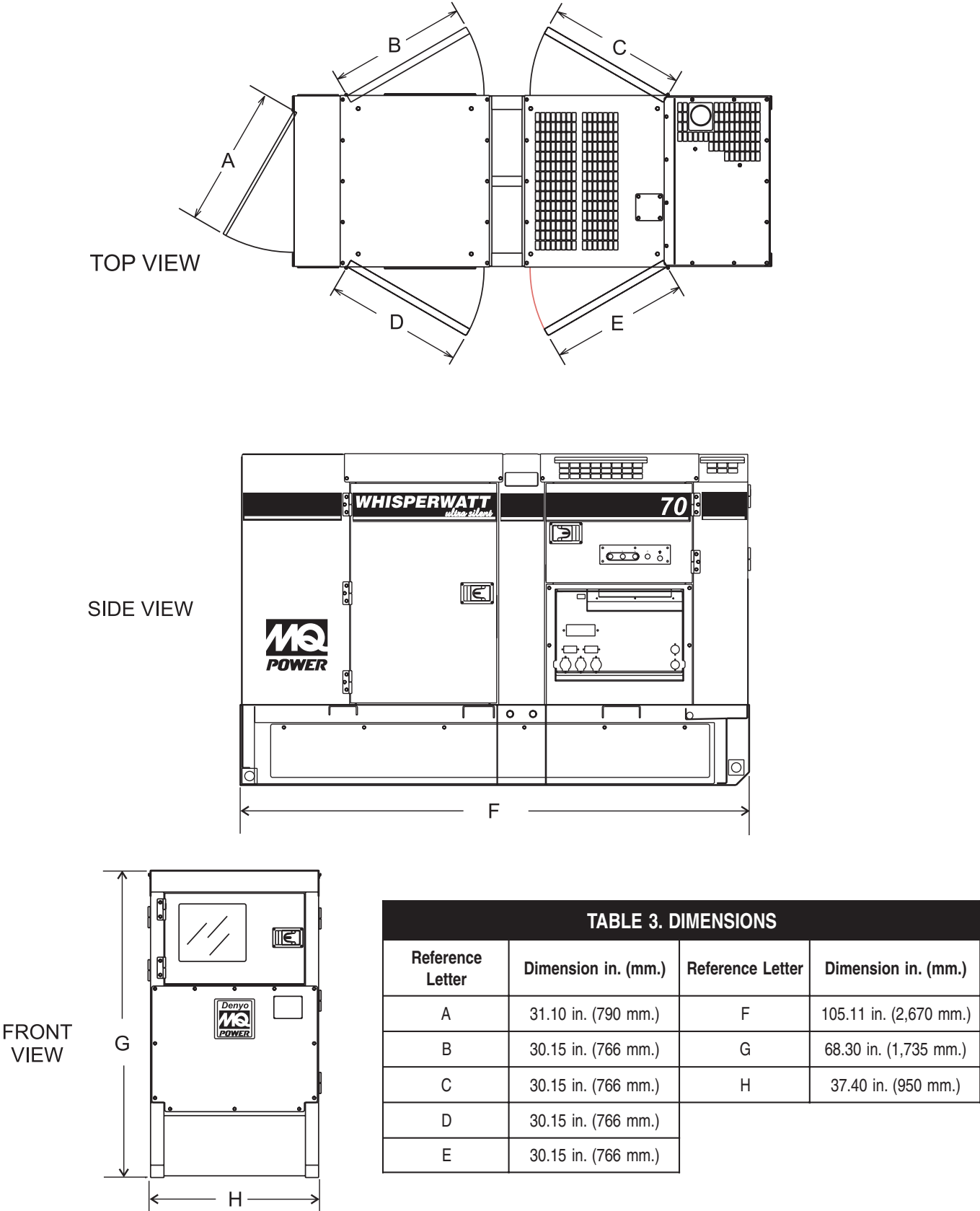
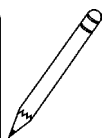
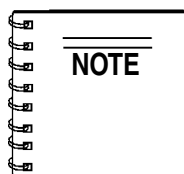

Figure 1. Dimensions

DCA- 70USI (60 Hz) — SAFETY MESSAGE ALERT SYMBOLS

FOR YOUR SAFETY AND THE SAFETY OF OTHERS!

Safety precautions should be followed at all times when operating this equipment. Failure to read and understand the Safety Messages and Operating Instructions could result in injury to yourself and others.



This **Operation and Parts** Manual has been developed to provide complete instructions for the safe and efficient operation of the MQ Power **Model DCA-70USI(60Hz) UltraSilent™ Generator**.

Before using this generator, ensure that the operating individual has read and understands all instructions in this manual.

SAFETY MESSAGE ALERT SYMBOLS

The three (3) Safety Messages shown below will inform you about potential hazards that could injure you or others. The Safety Messages specifically address the level of exposure to the operator, and are preceded by one of three words: **DANGER**, **WARNING**, or **CAUTION**.

DANGER

You **WILL** be **KILLED** or **SERIOUSLY** injured if you do not follow directions.

WARNING

You **COULD** be **KILLED** or **SERIOUSLY** injured if you do not follow directions.

CAUTION

You **CAN** be injured if you do not follow directions

HAZARD SYMBOLS

Potential hazards associated with the operation of this equipment will be referenced with "**Hazard Symbols**" which appear throughout this manual, and will be referenced in conjunction with Safety "**Message Alert Symbols**".

WARNING - LETHAL EXHAUST GASES



Gasoline engine exhaust gases contain poisonous carbon monoxide. This gas is colorless and odorless, and can cause **DEATH** if inhaled. **NEVER** operate this equipment in a confined area or enclosed structure that does not provide ample free flow air.

WARNING - EXPLOSIVE FUEL

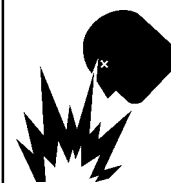

Gasoline is extremely flammable, and its vapors can cause an explosion if ignited. **DO NOT** start the engine near spilled fuel or combustible fluids. **DO NOT** fill the fuel tank while the engine is running or hot.

DO NOT overfill tank, since spilled fuel could ignite if it comes into contact with hot engine parts or sparks from the ignition system. Store fuel in approved containers, in well-ventilated areas and away from sparks and flames. **NEVER** use fuel as a cleaning agent.

WARNING - BURN HAZARDS



Engine components can generate extreme heat. To prevent burns, **DO NOT** touch these areas while the engine is running or immediately after operations. **NEVER** operate the engine with heat shields or heat guards removed.

DANGER - ELECTROCUTION HAZARDS

During operation of this generator, there exists the possibility of **electrocution**, **electrical shock or burn**, which can cause **severe bodily harm** or even **DEATH!**



DCA- 70USI (60 Hz) — SAFETY MESSAGE ALERT SYMBOLS

WARNING - ROTATING PARTS



NEVER operate equipment with covers, or guards removed. Keep **fingers, hands, hair** and clothing away from all moving parts to prevent injury.

CAUTION - RESPIRATORY HAZARDS



ALWAYS wear approved **respiratory** protection.

CAUTION - ACCIDENTAL STARTING



ALWAYS place the **Engine ON/OFF** switch in the **OFF** position and remove the ignition key when the pump is not in use.

CAUTION - SIGHT AND HEARING HAZARDS



ALWAYS wear approved **eye** and **hearing** protection.

CAUTION - OVER-SPEED CONDITIONS



NEVER tamper with the factory settings of the engine governor or settings. Personal injury and damage to the engine or equipment can result if operating in speed ranges above maximum allowable.

CAUTION - EQUIPMENT DAMAGE MESSAGES

Other important messages are provided throughout this manual to help prevent damage to your generator, other property, or the surrounding environment.

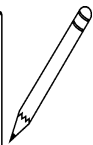
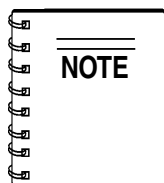

This generator, other property, or the surrounding environment could be damaged if you do not follow instructions.

DCA-70USI (60 Hz) — RULES FOR SAFE OPERATION

DANGER - READ THIS MANUAL!

Failure to follow instructions in this manual may lead to **serious injury** or even **DEATH!** This equipment is to be operated by trained and qualified personnel only! This equipment is for industrial use only.

The following safety guidelines should always be used when operating the **DCA-70USI (60 Hz) Ultra Silent™ Generator**.

General Safety:

- **DO NOT** operate or service this equipment before reading this entire manual.



The operator **MUST BE** familiar with proper safety precautions and operations techniques before using generator.

- This equipment should not be operated by persons under 18 years of age.
- **NEVER** operate this equipment without proper protective clothing, shatterproof glasses, steel-toed boots and other protective devices required by the job.



- **NEVER** operate this equipment when not feeling well due to fatigue, illness or taking medicine.
- **NEVER** operate this equipment under the influence or drugs or alcohol.



- **NEVER** use accessories or attachments, which are not recommended by MQ Power for this equipment. Damage to the equipment and/or injury to user may result.
- Manufacturer does not assume responsibility for any accident due to equipment modifications. Unauthorized equipment modification will void all warranties.
- Whenever necessary, replace nameplate, operation and safety decals when they become difficult read.

- **ALWAYS** check the machine for loosened threads or bolts before starting.

- **NEVER** operate the generator in an explosive atmosphere or near combustible materials. An explosion or fire could result causing severe **bodily harm or even death**.

- **NEVER** touch the hot exhaust manifold, muffler or cylinder. Allow these parts to cool before servicing engine or generator.



- **High Temperatures** – Allow the engine to cool before performing service and maintenance functions. Contact with **hot!** components can cause serious burns.

- The engine of this generator requires an adequate free flow of cooling air. **NEVER** operate the generator in any enclosed or narrow area where free flow of the air is restricted. If the air flow is restricted it will cause serious damage to the generator or engine and may cause injury to people. The generator engine gives off **DEADLY** carbon monoxide gas.

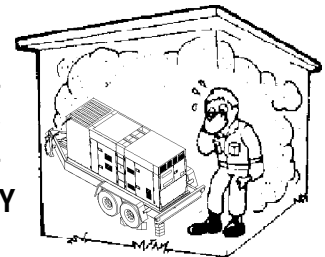

- **DO NOT** place hands or fingers inside generator engine compartment when engine is running.
- **NEVER** run engine without air filter. Severe engine damage may occur.
- **DO NOT** leave the generator running in the **manual mode** unattended.
- Refer to the **ISUZU Engine Owner's Manual** for engine technical questions or information.
- **ALWAYS** store equipment properly when it is not being used. Equipment should be stored in a clean, dry location out of the reach of children.

DCA-70USI (60 Hz) — RULES FOR SAFE OPERATION

Generator Grounding

To guard against electrical shock and possible damage to the equipment, it is important to provide a good **EARTH** ground.

Article 250 (Grounding) of the **National Electrical Code** (NEC) provides guide lines for proper grounding and specifies that the cable ground shall be connected to the grounding system of the building as close to the point of cable entry as practical.

The following safety recommendations should also be followed:

- **ALWAYS** make sure generator is properly grounded.
- **NEVER** use gas piping as an electrical ground.
- **ALWAYS** make sure that electrical circuits are properly **grounded** per the **National Electrical Code** (NEC) and local codes before operating generator. Severe **injury** or **DEATH!** by electrocution can result from operating an ungrounded generator.
- **ALWAYS** be sure to use the ground terminal (green wire) when connecting a load to the U,V, and W output terminal lugs.

Electrical Safety

- **ALWAYS** have a qualified electrician perform the generator wiring installation.
- **ALWAYS** make sure generator installation is accordance with the **National Electrical Code** (NEC) and local codes before operating generator.
- **NEVER** use a defective or frayed power cable. Check the cable for cuts in the insulation.
- **NEVER** use a extension cord that is frayed or damaged where the insulation has been cut.
- **ALWAYS** make certain that proper extension cord has been selected for the job. See Table 6.
- **NEVER** power cables or cords **lay in water**.
- **NEVER stand in water** while AC power from the generator is being transfer to a load.

⚠ DANGER - ELECTROCUTION HAZARDS

During operation of this generator, there exists the possibility of **electrocution, electrical shock or burn**, which can cause **severe bodily harm** or even **DEATH!**



To avoid these hazards:

NEVER use damaged or worn cables when connecting equipment to the generator. Make sure power connecting cables are securely connected to the generator's output terminals, insufficient tightening of the terminal connections may cause damage to the generator and electrical shock.

NEVER grab or touch a live power cord with wet hands.

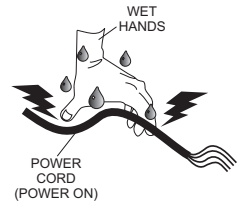

NEVER touch output terminals during operation. This is extremely dangerous. **ALWAYS** stop the machine and place the circuit breaker in the **OFF** position when contact with the output terminals is required.

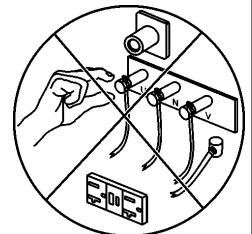

Backfeed to a utility system can cause **electrocution** and or property damage. **DO NOT** connect to any building's electrical system except through an approved device or after building main switch is opened. **ALWAYS** have a licensed electrician perform the installation

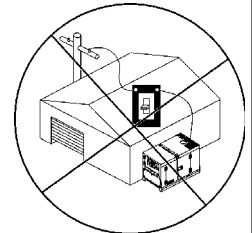

DCA-70USI (60 Hz) — RULES FOR SAFE OPERATION

Maintenance Safety

- The electrical voltage required to operate the generator can cause severe injury or even death through physical contact with live circuits. Turn all circuit breakers **OFF** before performing maintenance on the generator.
- **NEVER** lubricate components or attempt service on a running machine.
- **ALWAYS** disconnect the **NEGATIVE battery terminal** before performing service on the generator.
- Follow all Battery Safety Guidelines listed in this manual when handling or servicing the generator.
- **ALWAYS** allow the machine a proper amount of time to cool before servicing.
- Keep the machinery in proper running condition.
- Fix damage to the machine immediately and always replace broken parts.
- **ALWAYS** service air cleaner frequently to prevent engine malfunction.

WARNING - BURN HAZARDS

To prevent burns, **DO NOT** touch or open any of the below mentioned components while the engine is running or immediately after operations. Always allow sufficient time for the engine and generator to cool before performing maintenance.



- **Radiator Cap** - Removing the radiator cap while the engine is hot will result in high pressurized, boiling water to gush out of the radiator, causing severe scalding to any persons in the general area of the generator.
- **Coolant Drain Plug** - Removing the coolant drain plug while the engine is hot will result in hot coolant gushing out of the coolant drain plug, therefore causing severe scalding to any persons in the general area of the generator.
- **Engine Oil Drain Plug** - Removing the engine oil drain plug while the engine is hot will result in hot oil gushing out of the oil drain plug, therefore causing severe scalding to any persons in the general area of the generator.

Battery Safety

Use the following guidelines when handling the battery:

- The battery contains acids that can cause injury to the eyes and skin. To avoid eye irritation, **always** wear safety glasses.
- Use well insulated gloves when picking up the battery.

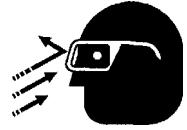

! DANGER - EXPLOSION HAZARDS

The risk of an explosion exists when performing service on the battery. To avoid **severe injury** or **DEATH**:

- **DO NOT** drop the battery. There is the possibility of risk that the battery may explode.
- **DO NOT** expose the battery to open flames, sparks, cigarettes etc. The battery contains combustible gases and liquids. If these gases and liquids come in contact with a flame or spark, an explosion could occur.

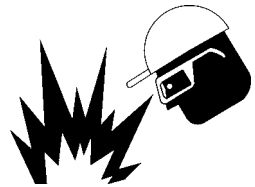

- **ALWAYS** keep the battery charged. If the battery is not charged a buildup of combustible gas will occur.
- **ALWAYS** keep battery charging and cables in good working condition. Repair or replace all worn cables.
- **ALWAYS** recharge the battery in an vented air environment, to avoid risk of a dangerous concentration of combustible gases.
- In case the battery liquid (dilute sulfuric acid) comes in contact with **clothing or skin**, rinse skin or clothing immediately with plenty of water.
- In case the battery liquid (dilute sulfuric acid) comes in contact with your **EYES**, rinse eyes immediately with plenty of water and contact the nearest doctor or hospital to seek medical attention.

DCA-70USI (60 Hz) — RULES FOR SAFE OPERATION

Towing & Transporting Safety

To reduce the possibility of an accident while transporting the generator on public roads, always make sure the trailer that supports the generator and the towing vehicle are in good operating condition and both units are mechanically sound.

The following list of safety precautions should be followed when towing your generator:

CAUTION - FOLLOW TOWING REGULATIONS

Check with your local county or state safety towing regulations, in addition to meeting **Department of Transportation (DOT) Safety Towing Regulations**, before towing your generator.

- **ALWAYS** shutdown engine before transporting.
- Tighten both fuel tank caps securely.
- If generator is mounted on a trailer, make sure trailer complies with all local and state safety transportation laws. Follow the listed **Towing & Transporting Safety** guidelines for basic towing techniques.
- Make sure the hitch and coupling of the towing vehicle are rated equal to, or greater than the trailer "gross vehicle weight rating."
- **ALWAYS** inspect the hitch and coupling for wear. **NEVER** tow a trailer with defective hitches, couplings, chains etc.
- Check the tire air pressure on both towing vehicle and trailer. **Trailer tires should be inflated to 50 psi cold.** Also check the tire tread wear on both vehicles.
- **ALWAYS** make sure the trailer is equipped with a "Safety Chain".
- **ALWAYS** attach trailer's safety chains to towing vehicle properly.
- **ALWAYS** make sure the vehicle and trailer directional, backup, brake, and trailer lights are connected and working properly.
- DOT Requirements include the following:
 - Connect and test electric brake operation.
 - Secure portable power cables in cable tray with tie wraps.

- The maximum speed for highway towing is **55 MPH** unless posted otherwise. Recommended off-road towing is not to exceed **15 MPH** or less depending on type of terrain.
- Place **chock blocks** underneath wheel to prevent **rolling**, while parked.
- Use the trailer's swivel jack to adjust the trailer height to a level position while parked.
- Avoid sudden stops and starts. This can cause skidding, or jack-knifing. Smooth, gradual starts and stops will improve towing.
- Avoid sharp turns.
- Trailer should be adjusted to a level position at all times when towing.
- Raise and lock trailer wheel stand in up position when transporting.
- Place **support blocks** underneath the trailer's bumper to prevent **tipping**, while parked.
- Avoid sharp turns to prevent rolling.
- **DO NOT** transport generator with fuel in tank.

Emergencies

- **ALWAYS** know the location of the nearest **fire extinguisher**.
- **ALWAYS** know the location of the nearest and **first aid kit**.
- **ALWAYS** know the location of the nearest phone or **keep a phone on the job site**, in case of emergencies.
- **ALWAYS** have easy access to the phone numbers of the nearest **Ambulance, Doctor** and **Fire Department**. This information will be invaluable in the case of an emergency.

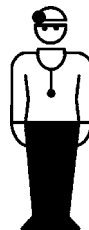
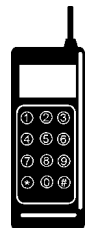

DCA-70USI (60 Hz) — GENERATOR DECALS

The **DCA-70USI (60 Hz) Whisperwatt™ Generator** is equipped with a number of safety decals (Figures 2 & 3). These decals are provided for operator safety and maintenance information. The illustration below and on the preceding page show the decals as they appear on the machine. Should any of these decals become unreadable, replacements can be obtained from your dealer.

OPERATING PROCEDURES

Manual Starting

1. Check the engine oil, coolant, and fuel levels. Replenish if necessary.
2. Place all Generator Circuit Breakers in the "OFF" position and close all doors.
3. Check that the Voltage select switch (or the Voltage change-over board) is present at desired voltage (in case of generator having multiple voltage ratings).
4. Set the Engine speed switch to the "LOW" position.
5. Turn the Auto-Off/Reset-Manual switch to the "Manual" position to start the engine. If the engine fails to start in the specified number of attempts, the overcrank lamp will indicate and the Auto-Off/Reset-Manual switch must be returned to the "Off/Reset" position before proceeding.
6. When the engine is ready for starting during cold weather operating conditions, push the intake heater button for approximately 30 seconds. Start engine using the Auto-Off/Reset-Manual switch to the "Manual" position. As soon as the engine starts, release the button. If the engine still does not start, utilize the water heater until water is warm. (If additional water heater is supplied.)
7. After starting, allow the engine to run for 1 or 2 minutes to warm-up. At temperatures below freezing, this time period must be extended to 2 to 4 minutes.
8. When the engine starts, immediately check for abnormal noise, vibration, fluid leakage or any indication of a problem. Check the control panel gauges. If all is normal, let the engine remain at the "Low" position for a short time, depending on the ambient conditions warm up.
9. After sufficient warm-up time has elapsed, set the Engine speed switch to the "High" position and the unit is ready for operation.
10. Check the NO-Load speed as shown in the table below.
80% operation—Approx. 80.0Hz (1800rpm)
11. Adjust the Voltage Regulator to the specified voltage.

Manual Stopping

1. Place the Generator Circuit Breakers in the "OFF" position.
2. Set the Engine speed switch to the "LOW" position, and allow the unit to cool for a few minutes.
3. Turn the Auto-Off/Reset-Manual switch, to the "Off/Reset" position.

Auto Starting/Stopping

1. With the Auto/Manual switch in the Auto position, the Auto Starting/Stopping controller monitors remote start contacts. Closure of the remote start contacts will begin engine cranking. When the contacts are opened cranking will stop or if running the engine will stop. All functions for the Automatic shutdown System work as in Manual Starting/stopping. For cold weather conditions utilize the water heater until water is warm. If the engine still does not start, please operate as in Manual Starting.

Emergency Stopping

1. Place the Generator Circuit Breakers in the "OFF" position.
2. Turn the Auto-Off/Reset-Manual switch to the "Off/Reset" position.

M35200010

P/N M352000103

SAFETY INSTRUCTIONS

Improper operation of this machine can cause severe injury or death.

- Read the instruction manual carefully before operating or servicing. This machine should only be operated by a person with sufficient knowledge and skill to ensure safe operation. High voltage circuits are located inside the output terminal cover and control panel.
- Close the cover and control panel before operating. Moving parts and hot surfaces are contained within the enclosure.
- Close all doors and lock them before operating.

M92010030

P/N M9520100304

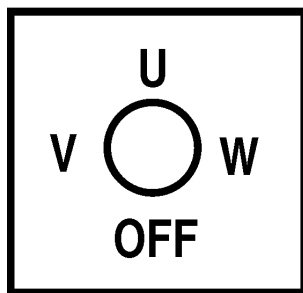

P/N M9520000104

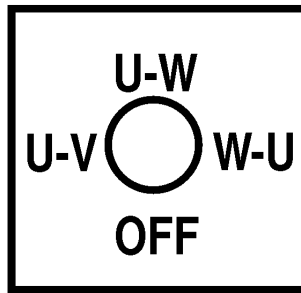

P/N M9520000204

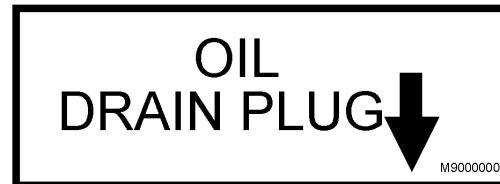

P/N M950000004



P/N M9510200002

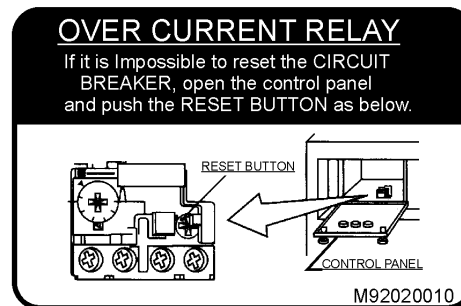

P/N M9520200104

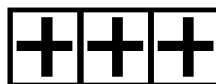

P/N M9500300104



P/N M9500300004



P/N M9500500004



P/N M9503000103

Figure 2. Generator Decals

DCA-70USI (60 Hz) — GENERATOR DECALS

	⚠ WARNING	⚠ WARNING	⚠ WARNING
	ELECTRIC SHOCK HAZARD <ul style="list-style-type: none"> Do not touch output terminals when this machine is operating. Turn power off before servicing 	ELECTRIC SHOCK HAZARD <ul style="list-style-type: none"> Always complete the grounding path from the ground terminal on this genset to an external grounding source. See instruction manual for details. 	<ul style="list-style-type: none"> Before connecting this generator to any building's electrical system, a licensed electrician must install an isolation (transfer) switch. Serious injury or death may result without this transfer switch

M9520 100503

P/N M9520100503

	⚠ WARNING
	HOT COOLANT can cause severe burns. <ul style="list-style-type: none"> Do not remove cap if radiator is hot.

M90310000

P/N M9503100004

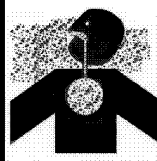
	⚠ WARNING
	ENGINE EXHAUST can cause severe injury or death. <ul style="list-style-type: none"> Use only in open, well ventilated areas or vent exhaust outside.

M90320000

P/N M9503200004

DANGER
HIGH VOLTAGE

M9520100401

P/N M9520100404

⚠ CAUTION
Stop engine before switching

M9520100204

P/N M9520100204

	⚠ CAUTION
	MOVING PARTS can cause severe injury. <ul style="list-style-type: none"> Do not operate with doors open. Stop engine before servicing.

M90300000

P/N M9503000004

NOTE
To use 50 amp receptacles, adjust the voltage selector switch to the single phase position and the main line circuit breaker to the on position.

P/N M1500020

P/N M1550000204

	⚠ CAUTION
	<ul style="list-style-type: none"> HOT PARTS can burn skin. Do not touch until the machine has sufficiently cooled.

M91010000

P/N M9510100004

	⚠ WARNING
	ELECTRIC SHOCK HAZARD <ul style="list-style-type: none"> Do not touch output terminals while this machine is operating. Turn power off before servicing.

P/N M9520100503

	⚠ WARNING
	ELECTRIC SHOCK HAZARD <ul style="list-style-type: none"> Do not touch internal wiring or connections while this machine is operating. Turn power off before servicing.

M92010000

P/N M9520100004

⚠ CAUTION
This machine stops and starts Automatically and without notice.

P/N B15200010

P/N B15200010

Figure 3. Generator Decals (Cont inued)

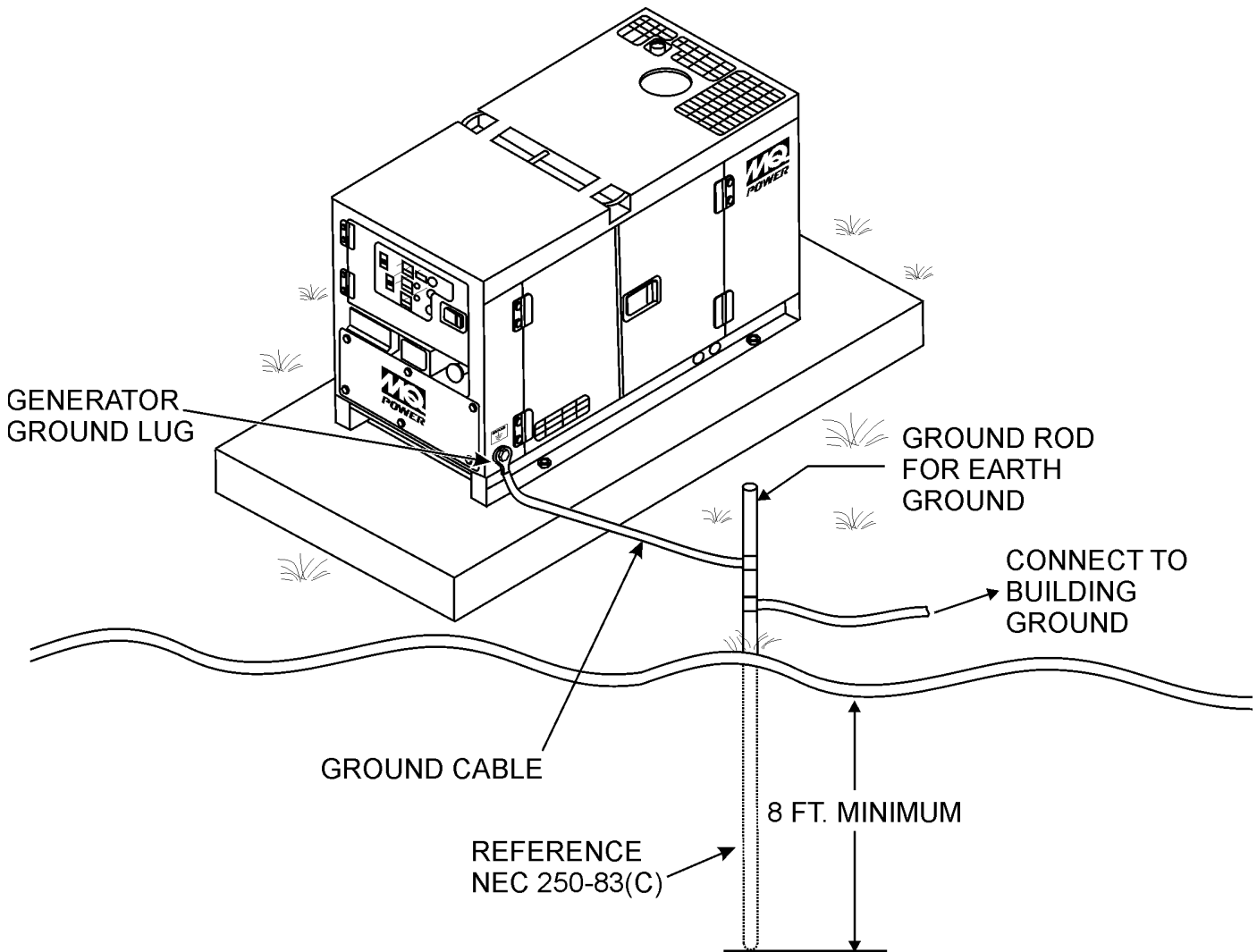

Figure 4. Typical Generator Grounding Application

Outdoor Installation

Install the generator in a area that is free of debris, bystanders, and overhead obstructions. Make sure the generator is on secure level ground so that it cannot slide or shift around. Also install the generator in a manner so that the exhaust will not be discharged in the direction of nearby homes.

The installation site must be relatively free from moisture and dust. All electrical equipment should be protected from excessive moisture. Failure to do will result in deterioration of the insulation and will result in short circuits and grounding.

Foreign materials such as dust, sand, lint and abrasive materials have a tendency to cause excessive wear to engine and alternator parts.

CAUTION - EXHAUST HAZARD

Pay close attention to ventilation when operating the generator inside tunnels and caves. The engine exhaust contains noxious elements. Engine exhaust must be routed to a ventilated area.

Indoor Installation

Exhaust gases from diesel engines are extremely poisonous. Whenever an engine is installed indoors the exhaust fumes must be vented to the outside. The engine should be installed at least two feet from any outside wall. Using an exhaust pipe which is too long or too small can cause excessive back pressure which will cause the engine to heat excessively and possibly burn the valves.

Mounting

The generator must be mounted on a solid foundation (such as concrete) and set firmly on the foundation to isolate vibration of the generator when it is running. The generator must set at least 6 inches above the floor or grade level (in accordance to NFPA 110, Chapter 5-4.1). **DO NOT** remove the metal skids on the bottom of the generator. They are to resist damage to the bottom of the generator and to maintain alignment.

Generator Grounding

To guard against electrical shock and possible damage to the equipment, it is important to provide a good **EARTH** ground.

Article 250 (Grounding) of the National Electrical Code (NEC) provides guide lines for proper grounding and specifies that the cable ground shall be connected to the grounding system of the building as close to the point of cable entry as practical.

NEC articles 250-64(b) and 250-66 set the following grounding requirements:

1. Use one of the following wire types to connect the generator to earth ground.
 - a. Copper - 10 AWG (5.3 mm²) or larger.
 - b. Aluminum - 8 AWG (8.4 mm²) or larger.
2. When grounding the generator (Figure 4) connect the ground cable between the lock washer and the nut on the generator and tighten the nut fully. Connect the other end of the ground cable to earth ground.
3. NEC article 250-52(c) specifies that the earth ground rod should be buried a minimum of 8 ft. into the ground.

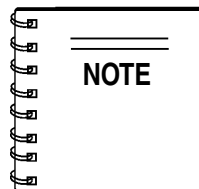

When connecting the generator to any buildings electrical system **ALWAYS** consult with a licensed electrician.

DCA-70USI Ultra Silent™ (60 Hz) Series Familiarization Generator

The MQ Power Model DCA-70USI (60 Hz) is a 56 kW generator (Figure 5) that is designed as a high quality portable (requires a trailer for transport) power source for telecom sites, lighting facilities, power tools, submersible pumps and other industrial and construction machinery.

Engine Operating Panel

The "Engine Operating Panel" is provided with the following:

- Tachometer
- Water Temperature Gauge
- Oil Pressure Gauge
- Charging Ammeter Gauge
- Fuel Level Gauge
- Pre-Heat Pushbutton
- Pre-Heat Lamp
- Panel Light/Panel Light Switch
- Auto ON/OFF Engine Controller (MPEC)
- Fuel Leak Detected Alarm Lamp

Generator Control Panel

The "Generator Control Panel" is provided with the following:

- Frequency Meter (Hz)
- AC Ammeter (Amps)
- AC Voltmeter (Volts)
- Ammeter Change-Over Switch
- Voltmeter Change-Over Switch
- Voltage Regulator
- 3-Pole, 175 amp Main Circuit Breaker
- "Control Box" (located behind the Gen. Control Panel)
 - Automatic Voltage Regulator
 - Current Transformer
 - Over-Current Relay
 - Voltage Rectifier
 - Starter Relay
 - Engine Controller (Computer Controlled)
 - Voltage Selector Switch

Output Terminal Panel

The "Output Terminal Panel" is provided with the following:

- Three 120/240V output receptacles (CS-6369), 50A
- Three auxiliary circuit breakers, 50A
- Two 120V output receptacles (GFCI), 20A
- Two GFCI circuit breakers, 20A
- Five output terminal lugs (3Ø power)
- Battery Charger (Optional)
- Water Heater (Optional)

Open Delta Excitation System

The DCA-70USI (60 Hz) generator is equipped with the state of the art "**Open-Delta**" excitation system. The open delta system consist of an electrically independent winding wound among stationary windings of the AC output section.

There are four connections of the open delta A, B, C and D. During steady state loads, the power from the voltage regulator is supplied from the parallel connections of A to B, A to D, and C to D. These three phases of the voltage input to the voltage regulator are then rectified and are the excitation current for the exciter section.

When a heavy load, such as a motor starting or a short circuit occurs, the automatic voltage regulator (AVR) switches the configuration of the open delta to the series connection of B to C. This has the effect of adding the voltages of each phase to provide higher excitation to the exciter section and thus better voltage response during the application of heavy loads.

The connections of the AVR to the AC output windings are for sensing only. No power is required from these windings.

The open-delta design provides virtually unlimited excitation current, offering maximum motor starting capabilities. The excitation does not have a "**fixed ceiling**" and responds according the demands of the required load.

Engine

The **DCA-70USI (60 Hz)** is powered by a 4 cycle, water cooled, direct injection, turbocharged **ISUZU Model FF-4BG1T Diesel Engine**. This engine is designed to meet every performance requirement for the generator. Reference Table 1 for engine specifications.

In keeping with MQ Power's policy of constantly improving its products, the specifications quoted herein are subject to change without prior notice.

Electric Governor System

The electric governor system controls the RPMs of the engine. When the engine demand increases or decreases, the governor system regulates the frequency variation to $\pm 0.25\%$.

Extension Cables

When electric power is to be provided to various tools or loads at some distance from the generator, extension cords are normally used. Cables should be sized to allow for distance in length and amperage so that the voltage drop between the generator and point of use (load) is held to a minimum. Use the cable selection chart (Table 6) as a guide for selecting proper extension cable size.

DCA-70USI (60 Hz) — MAJOR COMPONENTS

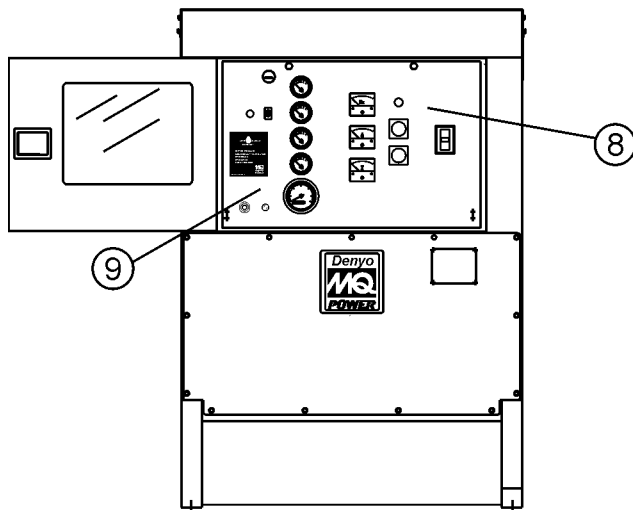
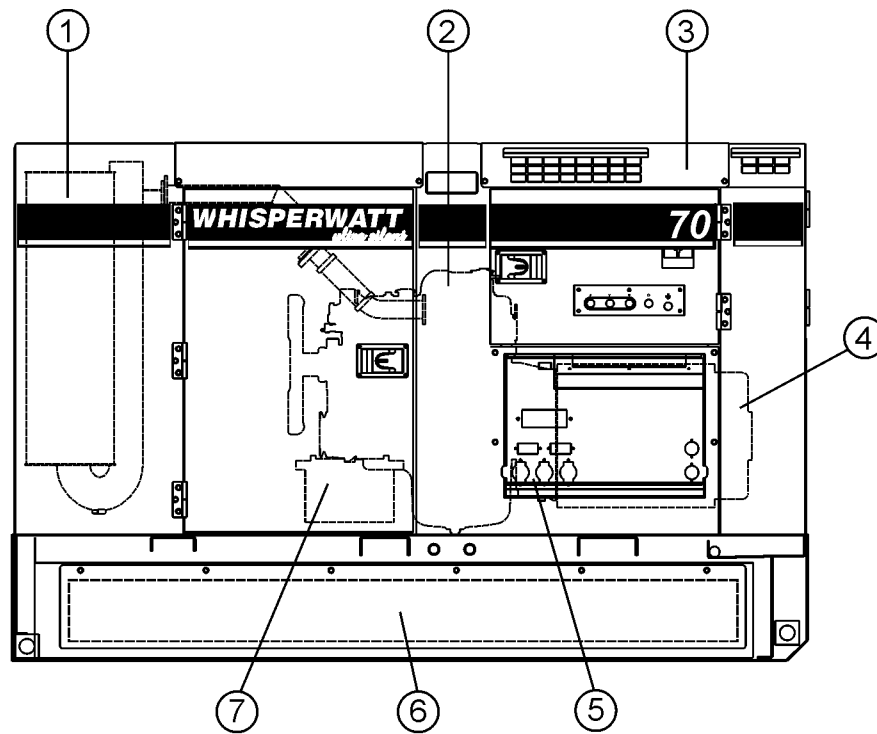

Table 4. Generator Major Components

ITEM NO.	DESCRIPTION
1	Muffler Assembly
2	Engine Assembly
3	Enclosure Assembly
4	Generator Assembly
5	Output Terminal Assembly
6	Fuel Tank Assembly
7	Battery Assembly
8	Generator Control Panel Assembly
9	Engine Operating Panel Assembly

Figure 5. Major Components

DCA-70USI (60 Hz) — GENERATOR CONTROL PANEL

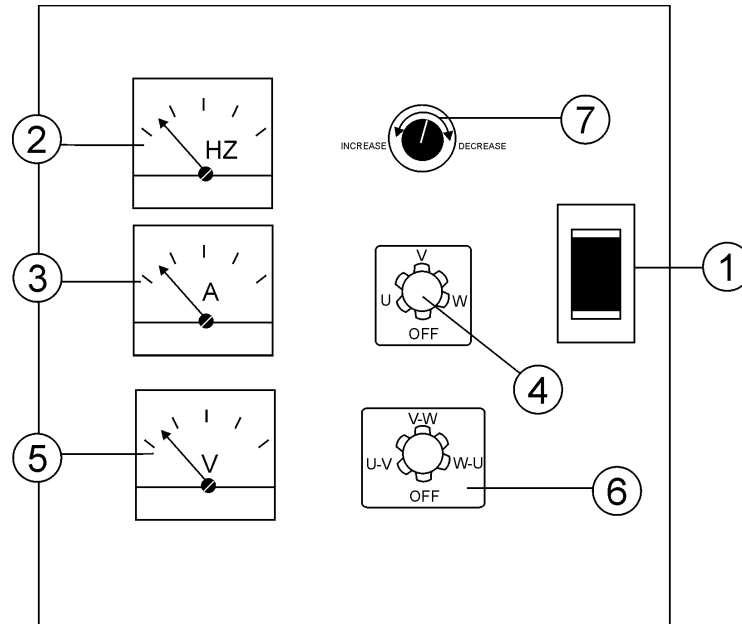

Figure 6. Generator Control Panel

The definitions below describe the controls and functions of the DCA-70USI (60 Hz) **Generator Control Panel** (Figure 6).

1. **Main Circuit Breaker** – This three-pole, 175A main breaker is provided to protect the the **U,V, and W Output Terminal Lugs** from overload.
2. **Frequency Meter** – Indicates the output frequency in hertz (Hz). Normally 60 Hz.
3. **AC Ammeter** – Indicates the amount of current the load is drawing from the generator per leg selected by the ammeter phase-selector switch.
4. **Ammeter Change-Over Switch** – This switch allows the AC ammeter to indicate the current flowing to the load connected to any phase of the output terminals, or to be switched off. This switch does not effect the generator output in any fashion, it is for current reading only.
5. **AC Voltmeter** – Indicates the output voltage present at the **U,V, and W Output Terminal Lugs**.
6. **Voltmeter Change-Over Switch** – This switch allows the AC voltmeter to indicate phase to phase voltage between any two phases of the output terminals or to be switched off.
7. **Voltage Regulator Control** – Allows $\pm 15\%$ manual adjustment of the generator's output voltage.

Located behind the generator control panel is the **Generator Control Box**. This box contains some of the necessary electronic components required to make the generator function.

The **Control Box** is equipped with the following major components:

- Over-Current Relay
- Automatic Voltage Regulator (AVR)
- Starter Relay
- Current Transformer
- Voltage Selector Switch
- Three Phase Circuit Breaker

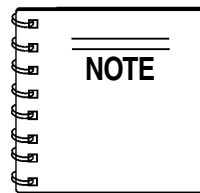

Remember the **overcurrent relay** monitors the current flowing from the **U,V, and W Output Terminal Lugs** to the load.

In the event of a short circuit or over current condition, it will automatically trip the 175 amp main breaker.

To restore power to the **Output Terminal Panel**, press the **reset** button on the overcurrent relay and place the **main** circuit breaker in the **closed** position (**ON**).

DCA-70USI (60 Hz) — ENGINE OPERATING PANEL

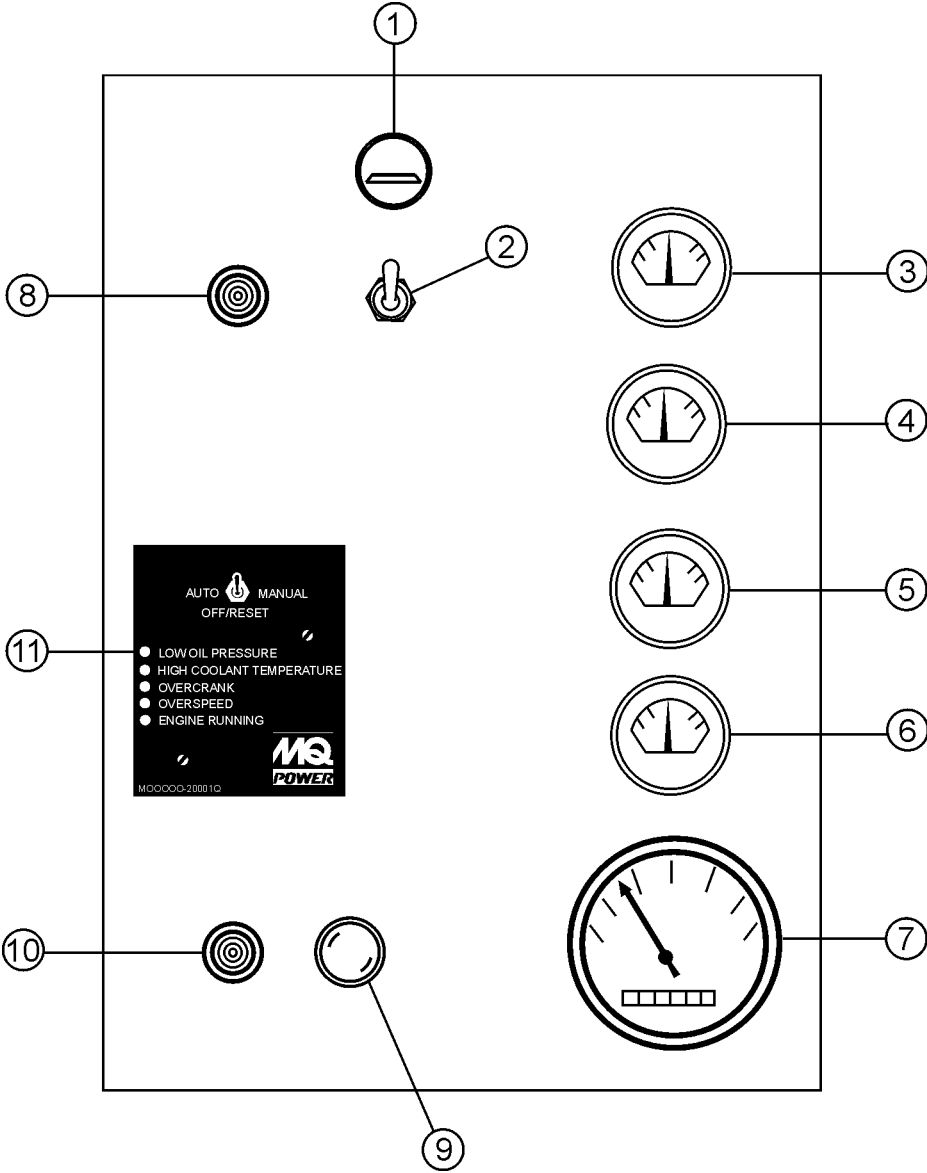

Figure 7. Engine Operating Panel

DCA-70USI (60 Hz) — ENGINE OPERATING PANEL

The definitions below describe the controls and functions of the DCA-70USI (60 Hz) **Engine Operating Panel** (Figure 7).

1. **Panel Light** – Normally used in dark areas or at night time. When activated, panel lights will illuminate. When the generator is not in use be sure to turn the panel light switch to the **OFF** position.
2. **Panel Light Switch** – When activated will turn on control panel light.
3. **Oil Pressure Gauge** – During normal operation this gauge be should read between 28 to 71 psi. (193~490 kPa). When starting the generator the oil pressure may read a little higher, but after the engine warms up the oil pressure should return to the correct pressure range.
4. **Water Temperature Gauge** – During normal operation this gauge be should read between 165° and 203°F.
5. **Charging Ammeter Gauge** – Indicates the current being supplied by the engine's alternator which provides current for generator's control circuits and battery charging system.
6. **Fuel Gauge** - Indicates amount of diesel fuel available.
7. **Tachometer** – Indicates engine speed in RPM's for 60 Hz operation. This meter should indicate 1800 RPM's when the rated load is applied. In addition a built in hour meter will record the number of operational hours that the generator has been in use.
8. **Fuel Leak Detected Alarm Lamp** – This lamp will illuminate when a leak in the fuel tank containment enclosure is detected.
9. **Pre-Heat Button** – Press and hold this button for 5 seconds to warm (cold weather) the engine glow plugs. While holding button down, verify that pre-heat lamp is on.
10. **Pre-Heat Lamp** – As the engine cranks, this lamp will illuminate to indicate automatic preheating of the engine. When the lamp turns off, the engine has been preheated and will start automatically.
11. **Auto On/Off Engine Controller (MPEC) –**

This controller has a vertical row of status LED's (inset), that when lit, indicate that an engine malfunction (fault) has been detected. When a fault has been detected the engine controller will evaluate the fault and all major faults will shutdown the generator.

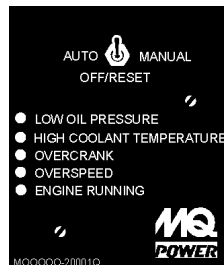

During **cranking cycle**, The MPEC will attempt to crank the engine for 10 seconds before disengaging. If the engine does not engage (start) by the third attempt, the engine will be shutdown by the engine controller's **Over Crank Protection** mode. If the engine engages at a speed (RPM's) that is not safe, the controller will shutdown the engine by initializing the **Over Speed Protection** mode.

Also the engine controller will shut down the engine in the event of low oil pressure, high coolant temperature, low coolant level, and loss of magnetic pickup. These conditions can be observed by monitoring the **LED** status indicators on the front of the controller module.

A. MPEC Control Switch – This switch controls the running of the unit. If this switch is set to the **OFF/RESET** position, the unit will not run. When this switch is set to the **MANUAL** position, the generator will start immediately.

If the generator is to be connected to a building's AC power source via a transfer switch (isolation), place the switch in the **AUTO** position. In this position the generator will monitor the AC line output from the building's power source.

B. Low Oil Pressure – Indicates the engine pressure has fallen below 15 psi. The oil pressure is detected using variable resistive values from the oil pressure sending unit. This is considered a **major** fault.

C. High Coolant Temperature – Indicates the engine temperature has exceeded 221°F. The engine temperature is detected using variable resistive values from the temperature sending unit. This is considered a **major** fault.

D. Overcrank Shutdown – Indicates the unit has attempted to start a pre-programmed number of times, and has failed to start. The number of cycles and duration are programmable. It is pre-set at 3 cycles with a 10 second duration. This is considered a **major** fault.

E. Overspeed Shutdown – Indicates the engine is running at an unsafe speed. This is considered a **major** fault.

F. Engine Running – Indicates that engine is running at a safe operating speed.

DCA-70USI (60 Hz) — OUTPUT TERMINAL PANEL FAMILIARIZATION

Output Terminal Panel

The **Output Terminal Panel** (Figure 8) shown below is located on the right-hand side (left from control panel) of the generator. Lift up on the cover to gain access to receptacles and terminal lugs.

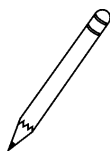
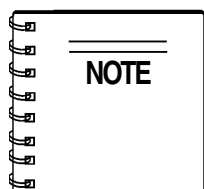

Terminal legs “O” and “Ground” are considered **bonded grounds**.

Output Terminal Familiarization

The “**Output Terminal Panel**” (Figure 8) is provided with the following:

- Three (3) 120/240V output receptacles @ 50 amp
- Three (3) Circuit Breakers @ 50 amps
- Two (2) 120V GFCI receptacles @ 20 amp
- Two (2) GFCI Circuit Breakers @ 20 amps
- Five (5) Output Terminal Lugs (U, V, W, O, Ground)

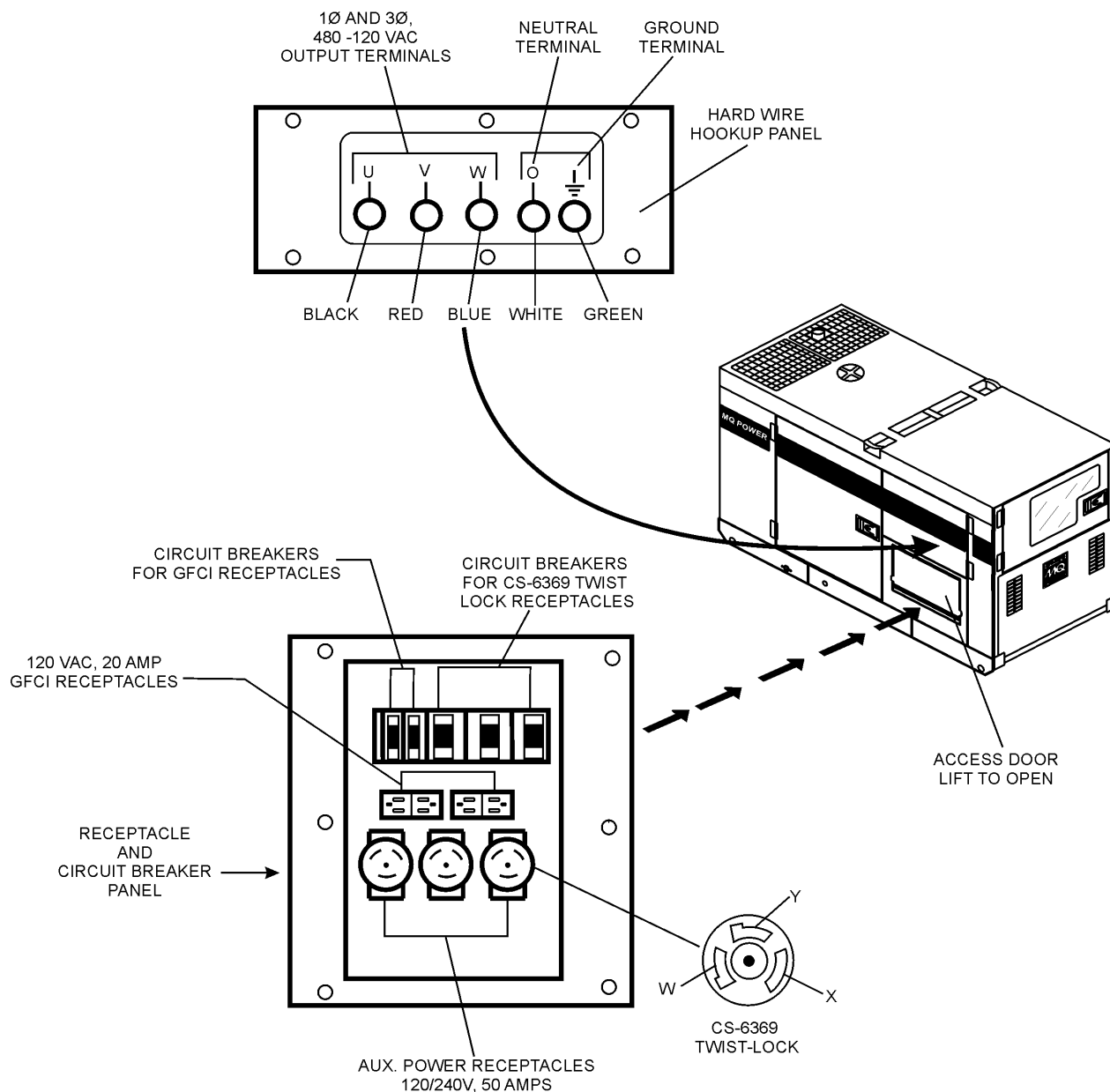

Figure 8. Output Terminal Panel

DCA-70USI (60 Hz) — OUTPUT TERMINAL PANEL FAMILIARIZATION

120 VAC GFCI Receptacles

There are two 120 VAC, 20 amp GFCI (Duplex Nema 5-20R) receptacles provided on the output terminal panel. These receptacles can be accessed in **any voltage selector switch** position. Each receptacle is protected by a 20 amp circuit breaker. These breakers are located directly above the GFCI receptacles. Remember the load output (current) of both GFCI receptacles is dependent on the load requirements of the U, V, and W output terminal lugs.

Pressing the **reset** button resets the GFCI receptacle after being tripped. Pressing the **Test Button** (See Figure 9) in the center of the receptacle will check the GFCI function. Both receptacles should be tested at least once a month.

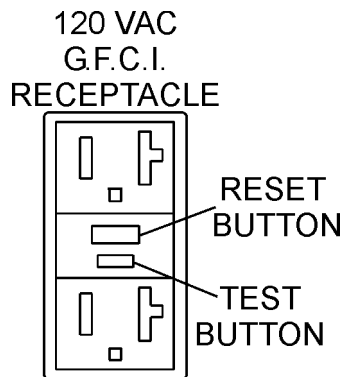

Figure 9. G.F.C.I. Receptacle

Twist Lock Dual Voltage 120/240 VAC Receptacles

There are three 120/240V, 50 amp auxilliary twist-lock (CS-6369) receptacles (Figure 10) provided on the output terminal panel. These receptacles can **only** be accessed when the voltage selector switch is placed in the **single-phase 240/120 position**.

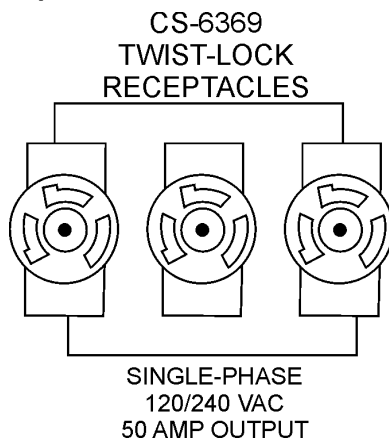

Figure 10. 120/240V Twist-Lock Auxiliary Receptacles

Each auxilliary receptacle is protected by a 50 amp circuit breaker. These breakers are located directly above the GFCI receptacles. Remember the load output (current) on all three receptacles is dependent on the load requirements of the **Output Terminal Lugs**.

Turn the **voltage regulator control knob** (Figure 11) on the control panel to obtain the desired voltage. Turning the knob clockwise will **increase** the voltage, turning the knob counter-clockwise will **decrease** the voltage.

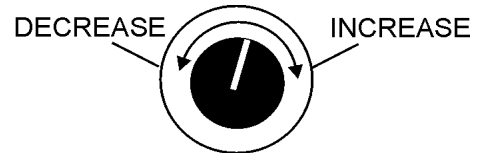

Figure 11. Voltage Regulator Control Knob

Removing the Plastic Face Plate (Hard Wire Hookup Panel)

The **Output Terminal Lugs** are protected by a plastic face plate cover (Figure 12). Un-screw the securing bolts and lift the plastic terminal cover to gain access to the terminal enclosure.

After the load wires have been securely attached to the terminal lugs, reinstall the plastic face plate.

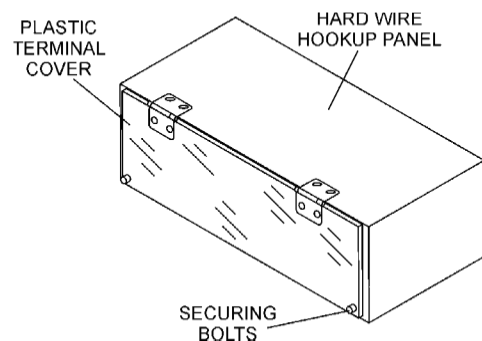

Figure 12. Plastic Face Plate (Output Terminal Lugs)

DCA-70USI (60 Hz) — OUTPUT TERMINAL PANEL FAMILIARIZATION

Connecting Loads

Loads can be connected to the generator by the **Output Terminal Lugs** or the convenience receptacles (Figure 13). Make sure to read the operation manual before attempting to connect a load to the generator.

To protect the output terminals from overload, a 3-pole, 175A **main** circuit breaker is provided. Make sure to switch **ALL** circuit breakers to the **OFF** position prior to starting the engine.

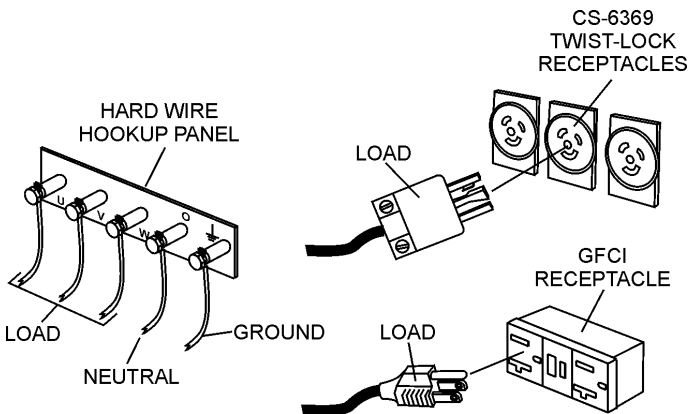

Figure 13. Connecting Loads

Over Current Relay

An **over current relay** (Figure 14) is connected to the main circuit breaker. In the event of an overload, both the circuit breaker and the over current relay may trip. If the circuit breaker can not be reset, the **reset button** on the over current relay must be pressed. The over current relay is located in the control box.

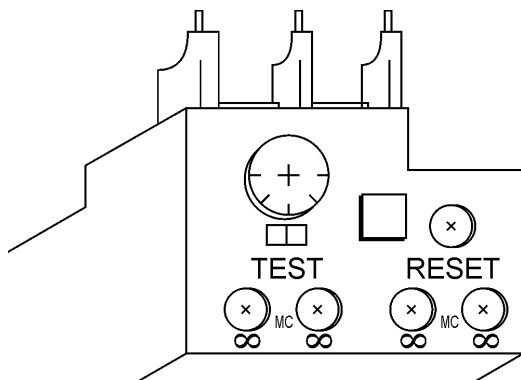

Figure 14. Over Current Relay

Blower Fan

This unit has an intake fan located at the rear of the machine to draw outside air into the cabinet to cool the engine. The fan has a 10 amp AC fuse located beneath the **Voltage Selector Switch** (Figure 15).

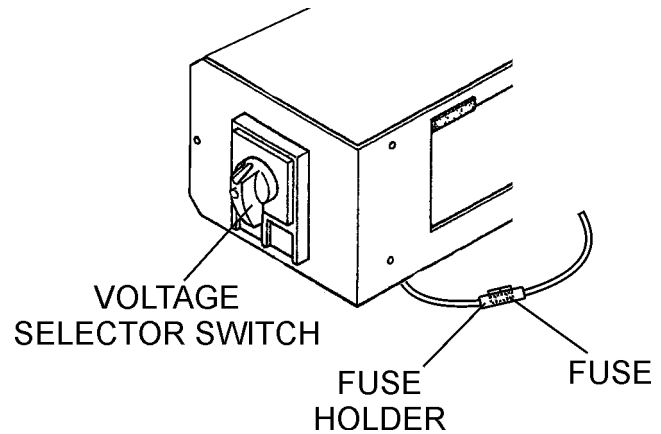

Figure 15. Blower Fan Fuse

! DANGER - ELECTROCUTION HAZARDS

This fuse has current running through it any time the engine is running. This fuse is **NOT** connected to the main circuit breaker of the generator. Attempting to replace the fuse with the engine and/or generator operating could result in **electrocution** and **severe bodily harm**. **ALWAYS** turn the unit completely off before attempting to replace or handle this fuse.



DCA-70USI (60 Hz) — LOAD APPLICATION

Single Phase Load

Always be sure to check the nameplate on the generator and equipment to insure the wattage, amperage, frequency, and voltage requirements are satisfactorily supplied by the generator for operating the equipment.

Generally, the wattage listed on the nameplate of the equipment is its rated output. Equipment may require 130—150% more wattage than the rating on the nameplate, as the wattage is influenced by the efficiency, power factor and starting system of the equipment.

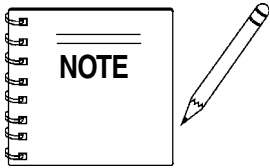

If wattage is not given on the equipment's name plate, approximate wattage may be determined by multiplying nameplate voltage by the nameplate amperage.

$$\text{WATTS} = \text{VOLTAGE} \times \text{AMPERAGE}$$

The power factor of this generator is 0.8. See Table 4 below when connecting loads.

Table 5. Power Factor By Load

Type Of Load	Power Factor
Single-phase induction motors	0.4 - 0.75
Electric heaters, incandescent lamps	1.0
Fluorescent lamps, mercury lamps	0.4 - 0.9
Electronic devices, communication equipment	1.0
Common power tools	0.8

Table 6. Cable Selection (60 Hz, Single Phase Operation)

Current in Amperes	Load In Watts		Maximum Allowable Cable Length			
	At 100 Volts	At 200 Volts	#10 Wire	#12 Wire	#14 Wire	#16 Wire
2.5	300	600	1000 ft.	600 ft.	375 ft.	250 ft.
5	600	1200	500 ft.	300 ft.	200 ft.	125 ft.
7.5	900	1800	350 ft.	200 ft.	125 ft.	100 ft.
10	1200	2400	250 ft.	150 ft.	100 ft.	
15	1800	3600	150 ft.	100 ft.	65 ft.	
20	2400	4800	125 ft.	75 ft.	50 ft.	

CAUTION: Equipment damage can result from low voltage.

Three Phase Load

When calculating the power requirements for 3-phase power use the following equation:

$$\text{KVA} = \frac{\text{VOLTAGE} \times \text{AMPERAGE} \times 1.732}{1000}$$

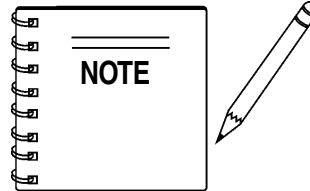

If 3Ø load (kVA) is not given on the equipment nameplate, approximate 3Ø load output may be determined by multiplying voltage by amperage by 1.732.

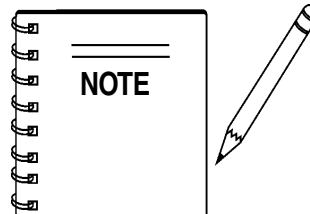

Motors and motor-driven equipment draw much greater current for starting than during operation.

An inadequate size connecting cable which cannot carry the required load can cause a voltage drop which can burn out the appliance or tool and overheat the cable. See Table 5.

- When connecting a resistance load such as an incandescent lamp or electric heater, a capacity of up to the generating set's rated output (kW) can be used.
- When connecting a fluorescent or mercury lamp, a capacity of up to the generating set's rated output (kW) multiplied by 0.6 can be used.
- When connecting an electric drill or other power tools, pay close attention to the required starting current capacity.

When connecting ordinary power tools, a capacity of up to the generating set's rated output (kW) multiplied by 0.8 can be used.

DANGER - ELECTRICAL SYSTEM HAZARDS

Before connecting this generator to any building's electrical system, a **licensed electrician** must install an **isolation (transfer) switch**. Serious damage to the building's electrical system may occur without this transfer switch.

DCA-70USI (60 Hz) — GENERATOR OUTPUTS

Voltage Selector Switch

The **voltage selector** switch (Figure 16) is located above the output terminal panel's **Hard Wire Hook-up Panel**. It has been provided for ease of voltage selection.

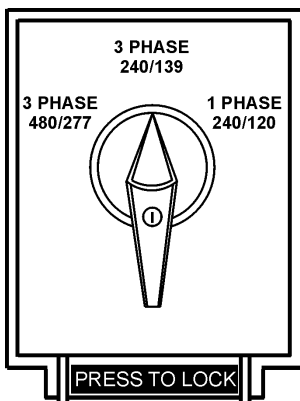

Figure 16. Voltage Selector Switch

Voltage Selector Switch Locking Button

The voltage selector switch has a locking button to protect the generator and load from being switched while the engine is running. To lock the voltage selector switch, **press** and **hold** the **red button** located at the bottom of the switch.

! CAUTION - CHANGING VOLTAGES

NEVER change the position of the **voltage selector switch** while the engine is running. **ALWAYS** place circuit breaker in the open position before selecting voltage.

Generator Output Voltages

A wide range of voltages are available to supply voltage for many different applications. Voltages are selected by using the **voltage selector** switch (Figure 15). To obtain some of the voltages as listed in Table 7 (see below) will require a fine adjustment using the **voltage regulator (VR) control knob** located on the control panel.

	208V	220V	240V	416V	440V	480V
Three Phase (Switchable)						
Single Phase (Switchable)	120V	127V	139V	240V	254V	277V

Generator Amperage

Table 8 describes the generator's current output capability for both 1Ø-phase and 3Ø phase applications.

DCA-70USI	kW	kVA	120V	240V	480V
Single Phase	40	N/A	166A x 2	168A	N/A
Three Phase*	56	70	N/A	168A	84A
* Power Factor = 0.8					

GFCI Receptacle Load Capability

The load capability of the GFCI receptacles is directly related to the voltage being supplied at either the output terminals or the 2 twist lock auxiliary receptacles.

Tables 9 and 10 show what amount of current is available at the GFCI receptacles when the output terminals and twist lock receptacles are in use. Be careful that your load does not to exceed the available current capability at the receptacles.

KW in Use Twist-Lock (CS6369)	Available Load Current (Amps)
1Ø 240/120V	GFCI Duplex NEMA 5-20R 120V
40.4	0
39.2	5 amps per receptacle
38.0	10 amps per receptacle
36.8	15 amps per receptacle
35.6	20 amps per receptacle

KVA in Use (UVWO Terminals)	Available Load Current (Amps)
3Ø 240/480V	GFCI Duplex NEMA 5-20R 120V
70	0
65.8	5 amps per receptacle
61.7	10 amps per receptacle
57.5	15 amps per receptacle
53.4	20 amps per receptacle

How to Read the Output Terminal Gauges.

The gauges and selector switches on the control panel **DO NOT** effect the generator output. They are provided to help observe how much power is being supplied at the **Output terminals lugs**.

Before taking a reading from either gauge, set the **Voltage Selector Switch** (Figure 17) to the position which produces the required voltage (For example, for 3Ø 240V, choose the center 3Ø 240/139V position on the volt- selector switch.)

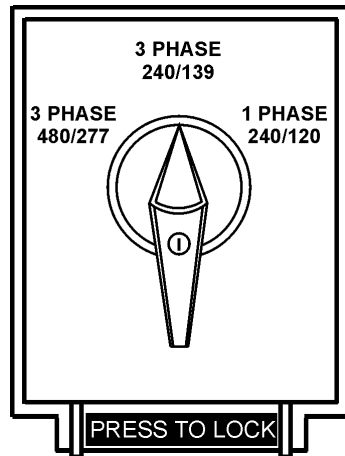
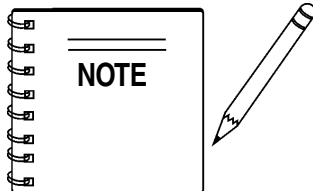

Figure 17. Voltage Selector Switch 240/139V Three Phase Position



For 3Ø 208V/1Ø,120V, place the Voltage Selector Switch in the 3 Phase 240/139 position.

Reading Amperage

To determine the amperage at a terminal lug, set the **AC Ammeter Change-Over Switch** to the appropriate setting (Figure 20) to activate the **AC Ammeter Gauge** (Figure 21) and read the available amperage at the terminal lug.

For example, to measure the amperage at the U terminal lug, set the **AC Ammeter Change-Over Switch** to U and read the **AC Ammeter Gauge**.

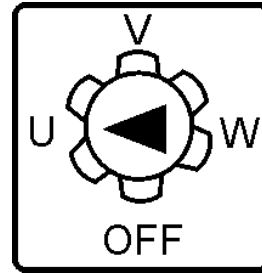

Figure 20. AC Ammeter Change-Over Switch

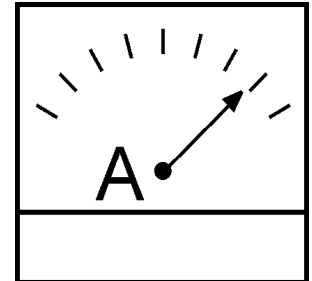
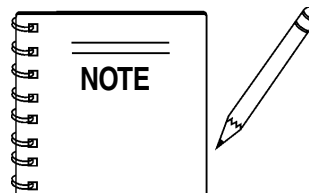

Figure 21. AC Ammeter (Amp reading on U lug)



The **ammeter** gauge will only show a reading when the **Output Terminal Lugs** are connected to a load and in use.

Reading Voltage

To determine the voltage between two terminal lugs, set the **AC Voltmeter Change-Over Switch** to the appropriate setting (Figure 18) to activate the **AC Voltmeter Gauge** (Figure 19) and read the available voltage between the two lugs.

For example, to measure the voltage between the W and U terminal lugs, set the **AC Voltmeter Change-Over Switch** to W-U and read the **AC Voltmeter Gauge**.

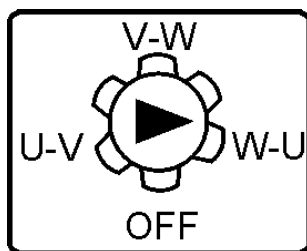

Figure 18. AC Voltmeter Change-Over Switch

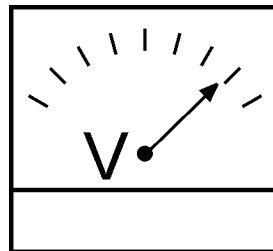

Figure 19. AC Voltmeter Gauge (Volt reading on W-U Lug)

DCA-70USI (60 Hz) — OUTPUT TERMINAL PANEL CONNECTIONS

UVWO Terminal Output Voltages

Various output voltages can be obtained using the **Output Terminal Lugs**. The voltages at the terminals are dependent on the position of the **Voltage Selector Switch** and the adjustment of the **Voltage Regulator Control Knob**.

Remember the voltage selector switch determines the **range** of the output voltage. The voltage regulator (VR) allows the user to increase or decrease the selected voltage.

3Ø 240/139 Output Terminal Lug Voltages

1. Place the voltage selector switch in the 3Ø 240/139 position as shown in Figure 22.

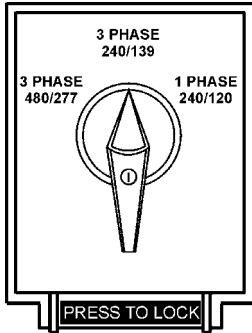

Figure 22. Voltage Selector Switch 240/139V Three-Phase Position

2. Connect the load wires to the **Output Terminal Lugs** as shown in Figure 23.

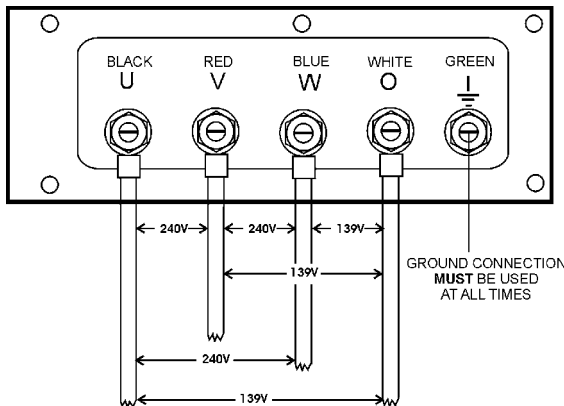

Figure 23. Output Terminal Lugs 3Ø-240/139V Connections

3. Turn the voltage regulator knob (Figure 23) clockwise to increase voltage output, turn counterclockwise to decrease voltage output.

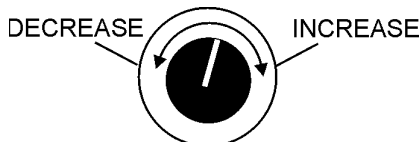
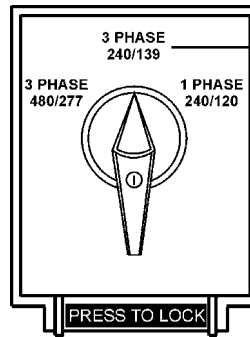

Figure 24. Voltage Regulator Knob (139V/240V)

3Ø 208V/1Ø120V Output Terminal Lug Voltages

1. Place the voltage selector switch in the 3Ø 240/139 position as shown in Figure 25.



Use this position for 3Ø-240 or 1Ø120V.

Figure 25. Voltage Selector Switch 240/139V Three-Phase Position

2. Connect the load wires to the **Output Terminal Lugs** as shown in Figure 26.

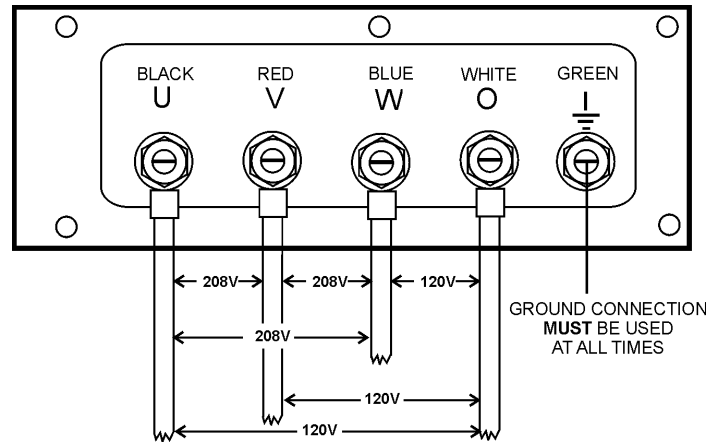
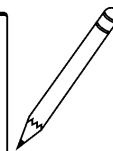
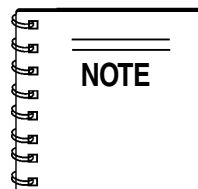

Figure 26. Output Terminal Lugs 3Ø-208/120V Connections

3. Turn the voltage regulator knob (Figure 24) clockwise to increase voltage output, turn counterclockwise to decrease voltage output.



To achieve a 3Ø 208V output the voltage selector switch must be in the 3Ø-240/139 position and the voltage regulator must be adjusted to 208V.

DCA-70USI (60 Hz) — OUTPUT TERMINAL PANEL CONNECTIONS

3Ø 480/277 Output Terminal Lug Voltages

1. Place the voltage selector switch in the 3Ø 480/277 position as shown in Figure 27.

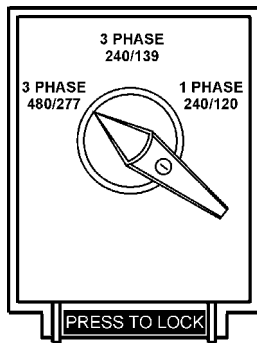

Figure 27. Voltage Selector Switch 480/277V Three-Phase Position

1Ø 240V/120V Output Terminal Lug Voltages

1. Place the voltage selector switch in the 1Ø 240/120 position as shown in Figure 29.

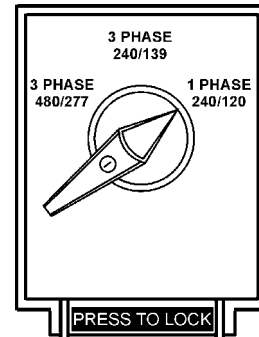

Figure 29. Voltage Selector Switch 240/120V Single-Phase Position

2. Connect the load wires to the **Output Terminal Lugs** as shown in Figure 28.

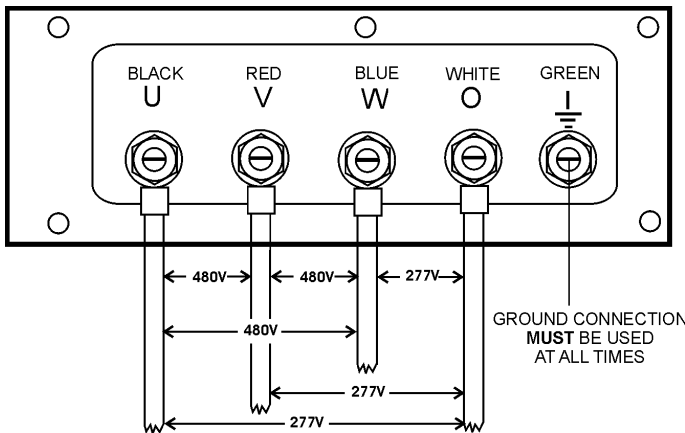

Figure 28. Output Terminal Lugs 3Ø-480/277V Connections

2. Connect the load wires to the **Output Terminal Lugs** as shown in Figure 30.

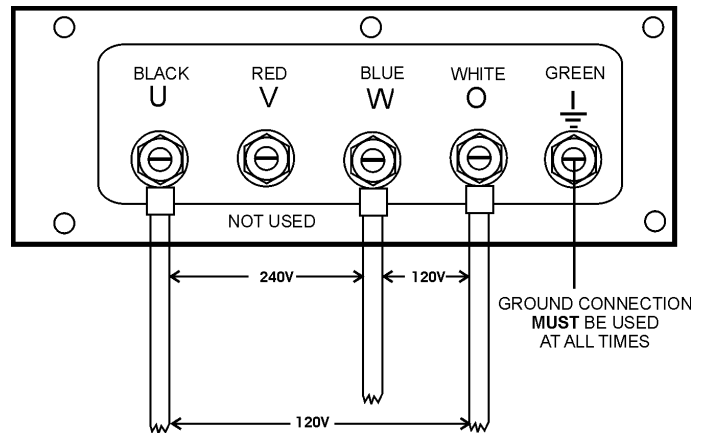

Figure 30. Output Terminal Lugs 1Ø-240/120V Connections

3. Turn the voltage regulator knob (Figure 24) clockwise to increase voltage output, turn counterclockwise to decrease voltage output.

3. Turn the voltage regulator knob (Figure 25) clockwise to increase voltage output, turn counterclockwise to decrease voltage output.

Circuit Breakers

To protect the generator from an overload, a 3-pole, 175 amp, **main** circuit breaker is provided to protect the **U, V, and W Output Terminals** from overload. In addition two single-pole, 20 amp **GFCI** circuit breakers are provided to protect the GFCI receptacles from overload. Three 50 amp **load** circuit breakers have also been provided to protect the auxiliary receptacles from overload. Make sure to switch **ALL** circuit breakers to the **OFF** position prior to starting the engine.

Lubrication Oil

Fill the engine crankcase with lubricating oil through the filler hole, but **DO NOT** overfill. Make sure the generator is level, and verify that the oil level is maintained between the two notches (Figure 31) on the dipstick. See Table 11 for proper selection of engine oil.

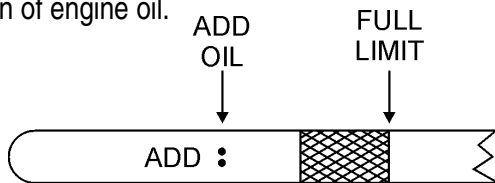

Figure 31. Engine Oil Dipstick

When checking the engine oil, be sure to check if the oil is clean. If the oil is not clean, drain the oil by removing the oil drain plug, and refill with the specified amount of oil as outlined in the **ISUZU Engine Owner's Manual**. Oil should be warm before draining.

Other types of motor oils may be substituted if they meet the following requirements:

- API Service Classification CC/SC
- API Service Classification CC/SD
- API Service Classification CC/SE
- API Service Classification CC/SF

Table 11. Recommended Motor Oil		OIL: SAE	
°F	°C		
122	50		
104	40	10W/40	30
86	30		
68	20		
50	10		
32	0		
-14	-10	5W/30	ARCTIC OIL
-4	-20		
-22	-30	15W/30	
-40	-40	10W/30	
		10W	
		20W/40	

Fuel Check

! DANGER - EXPLOSION/FIRE HAZARDS

Fuel spillage on a **hot** engine can cause a **fire** or **explosion**. If fuel spillage occurs, wipe up the spilled fuel completely to prevent fire hazards. **NEVER** smoke around or near the generator.

Refilling the Fuel System

! CAUTION - REFUELING THE GENERATOR

ONLY properly trained personnel who have read and understand this section should refill the fuel tank system.

This generator has an internal fuel tank located inside the trailer frame and may also be equipped with an environmental fuel tank (Figure 32). **ALWAYS** fill the fuel tanks with clean fresh **#2 diesel fuel**. **DO NOT** fill the fuel tanks beyond their capacities.

Pay attention to the fuel tank capacity when replenishing fuel. The fuel tank cap must be closed tightly after filling. Handle fuel in a safety container. If the container does not have a spout, use a funnel. Wipe up any spilled fuel immediately.

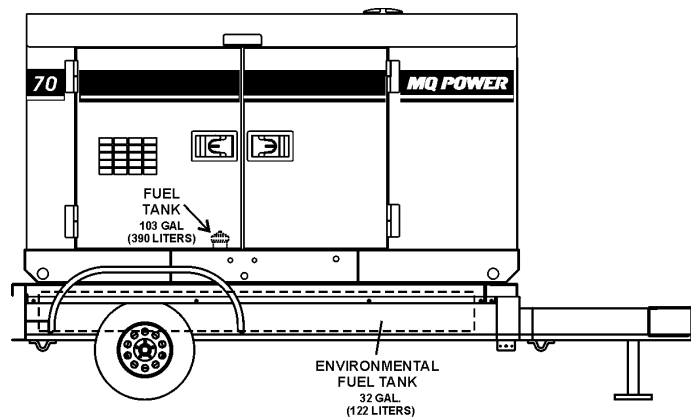

Figure 32. Internal Fuel Tank System

Refueling Procedure:

! WARNING - RESPIRATORY HAZARDS

Diesel fuel and its vapors are dangerous to your health and the surrounding environment. Avoid skin contact and/or inhaling fumes.



1. **Level Tanks** – Make sure fuel cells are level with the ground. Failure to do so will cause fuel to spill from the tank before reaching full capacity (Figure 33).

! CAUTION - REFUELING THE GENERATOR

ALWAYS place trailer on firm level ground before refueling to prevent spilling and maximize the amount of fuel that can be pumped into the tank.

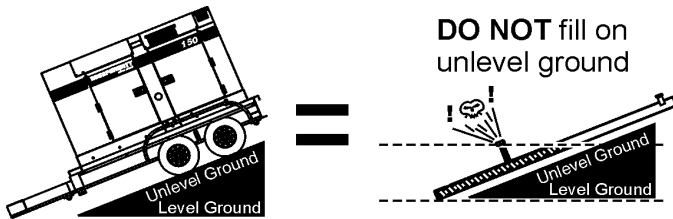
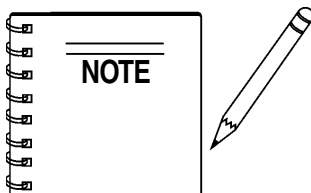

Figure 33. Only Fill on Level Ground



ONLY! use #2 diesel fuel when refueling.

3. Open cabinet doors on the “right side” of the generator (from generator control panel position). Remove fuel cap and fill tank (Figure 34).

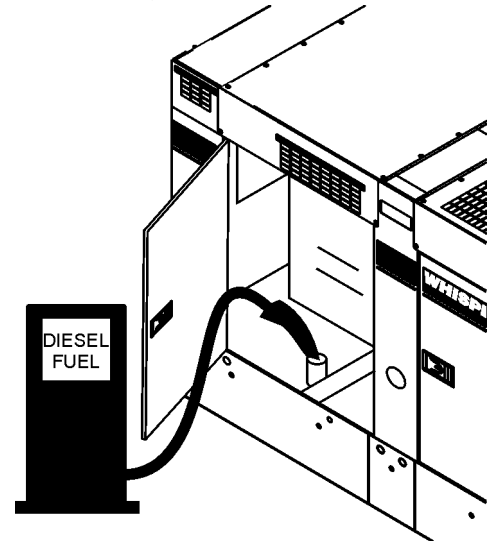

Figure 34. Fueling the Generator

3. **NEVER** overfill fuel tank – It is important to read the fuel gauge when filling trailer fuel tank. **DO NOT** wait for fuel to rise in filler neck (Figure 35).

FUEL GAUGE LOCATED ON CONTROL PANEL

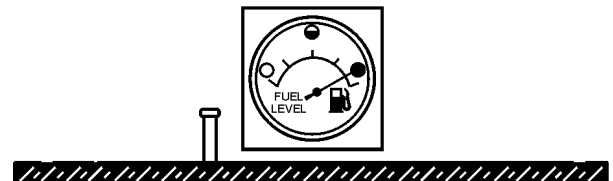

Figure 35. Full Fuel Tank

! CAUTION - REFUELING THE GENERATOR

DO NOT OVER-FILL fuel system. Leave room for fuel expansion. Fuel expands when heated (Figure 36).



Figure 36. Fuel Expansion

Coolant (ISUZU Antifreeze/Summer Coolant/Water)

ISUZU recommends ISUZU Antifreeze/Summer Coolant for use in their engines, which can be purchased in concentrate (and mixed with 50% demineralized water) or pre-diluted. See the **ISUZU Engine Owner's Manual** for further details.

! WARNING - BURN HAZARDS

If adding coolant/antifreeze mix to the radiator, **DO NOT** remove the radiator cap until the unit has completely cooled. The possibility of **hot!** coolant exists which can cause severe burns.



Day-to-day addition of coolant is done from the recovery tank. When adding coolant to the radiator, **DO NOT** remove the radiator cap until the unit has completely cooled. See Table 12 for engine, radiator, and recovery tank coolant capacities. Make sure the coolant level in the recovery tank is always between the "H" and the "L" markings.

Engine and Radiator	3.8 Gal. (14.4 liters)
Reserve Tank	2 Quarts (1.9 liters)

Operation Freezing Weather

When operating in freezing weather, be certain the proper amount of antifreeze (Table 13) has been added.

Vol % Anti-Freeze	Freezing Point	
	°C	°F
50	-37	-34

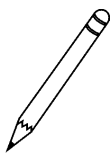
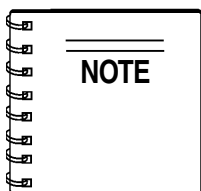

When the antifreeze is mixed with water, the antifreeze mixing ratio **must be** less than 50%.

Cleaning the Radiator

The engine may overheat if the radiator fins become overloaded with dust or debris. Periodically clean the radiator fins with compressed air. Cleaning inside the machine is dangerous, so clean only with the engine turned off and the **negative** battery terminal disconnected.

Air Cleaner

Periodic cleaning/replacement is necessary. Inspect it in accordance with the **ISUZU Engine Owner's Manual**.

Fan Belt Tension

A slack fan belt may contribute to overheating, or to insufficient charging of the battery. Inspect the fan belt for damage and wear and adjust it in accordance with the **ISUZU Engine Owner's Manual**.

The fan belt tension is proper if the fan belt bends 10 to 15 mm (Figure 37) when depressed with the thumb as shown below.

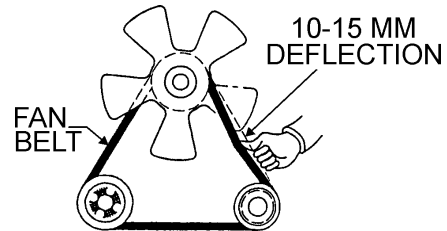
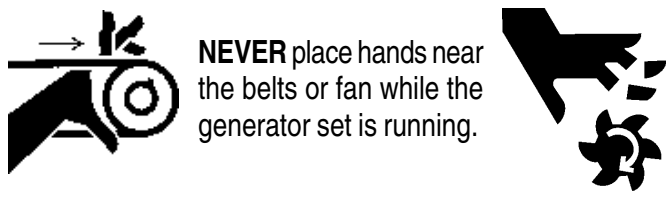

Figure 37. Fan Belt Tension

! CAUTION - ROTATING PARTS

NEVER place hands near the belts or fan while the generator set is running.



Battery

This unit is of negative ground **DO NOT** connect in reverse. Always maintain battery fluid level between the specified marks. Battery life will be shortened, if the fluid level are not properly maintained. Add only distilled water when replenishment is necessary.

DO NOT over fill. Check to see whether the battery cables are loose. Poor contact may result in poor starting or malfunctions. **Always** keep the terminals firmly tightened. Coating the terminals with an approved battery terminal treatment compound. Replace battery with only recommended type battery. The battery type used in this generator is BCI Group 27.

The battery is sufficiently charged if the specific gravity of the battery fluid is 1.28 (at 68° F). If the specific gravity should fall to 1.245 or lower, it indicates that the battery is dead and needs to be recharged or replaced.

Before charging the battery with an external electric source, be sure to disconnect the battery cables.

Battery Cable Installation

ALWAYS be sure the battery cables (Figure 38) are properly connected to the battery terminals as shown below. The **Red Cable** is connected to the positive terminal of the battery, and the **Black Cable** is connected to the negative terminal of the battery.

! CAUTION - BATTERY SERVICING SAFETY

ALWAYS disconnect the negative terminal **FIRST** and reconnect negative terminal **LAST**.

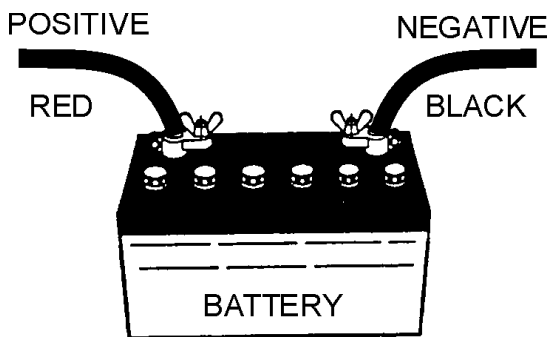
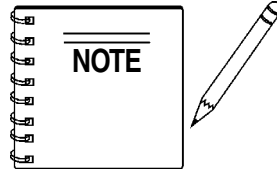

Figure 38. Battery Connections

When connecting battery do the following:

1. **NEVER** connect the battery cables to the battery terminals when the **MPEC Control Switch** is in either the **MANUAL** position. **ALWAYS** make sure that the **MPEC Control Switch** is in the **OFF/RESET** position when connecting the battery.
2. Place a small amount of battery terminal treatment compound around both battery terminals. This will ensure a good connection and will help prevent corrosion around the battery terminals.



If the battery cable is connected incorrectly, electrical damage to the generator will occur. Pay close attention to the polarity of the battery when connecting the battery.

! CAUTION - BATTERY SERVICING SAFETY

Inadequate battery connections may cause poor starting of the generator, and create other malfunctions.

Alternator

The polarity of the alternator is negative grounding type. When an inverted circuit connection takes place, the circuit will be in short circuit instantaneously resulting the alternator failure.

DO NOT put water directly on the alternator. Entry of water into the alternator can cause corrosion and damage the alternator.

Wiring

Inspect the entire generator for bad or worn electrical wiring or connections. If any wiring or connections are exposed (insulation missing) replace wiring immediately.

Piping and Hose Connection

Inspect all piping, oil hose, and fuel hose connections for wear and tightness. Tighten all hose clamps and check hoses for leaks.

If any hose (**fuel** or **oil**) lines are defective replace them immediately.

DCA-70USI (60 Hz) — GENERATOR START-UP PROCEDURE (MANUAL)

Before Starting

CAUTION - LETHAL EXHAUST HAZARD

The engine's exhaust contains harmful emissions. **ALWAYS have adequate ventilation when operating.** Direct exhaust away from nearby personnel.

WARNING - STARTING THE GENERATOR

NEVER! manually start the engine with the **main, GFCI** or **auxiliary** circuit breakers in the **ON** (closed) position.

1. Place the **main, G.F.C.I.,** and **aux.** circuit breakers (Figure 39) in the **OFF** position prior to starting the engine.

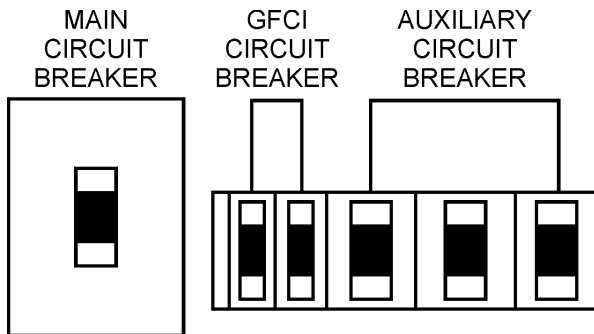
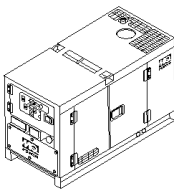
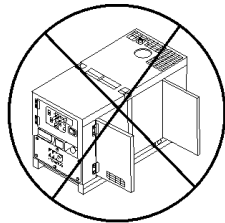

Figure 39. Main, Aux. and GFCI Circuit Breakers (OFF)

2. Connect the load to the **receptacles** or the **Output Terminal Lugs** as shown in Figure 13. These load connection points can be found on the output terminal panel and the output terminal panel's hard wire hookup panel.
3. The output terminal lugs are protected by a plastic cover. Remove this cover to gain access to the terminals. Tighten terminal nuts securely to prevent load wires from slipping out.
4. Close all engine enclosure doors (Figure 40).



CORRECT



INCORRECT

Figure 40. Engine Enclosure Doors

5. Place the **voltage selector switch** in the desired voltage position (Figure 41).

Figure 41. Voltage Selector Switch

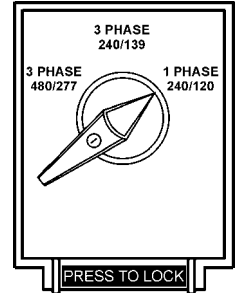

6. Press and hold the **pre-heat button** (Figure 42) for at least 5 seconds to warm the engine glow plugs.

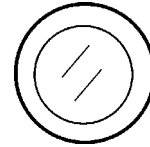

Figure 42. Pre-Heat Button

7. Verify that the **pre-heat lamp** (Figure 43) is lit. The lamp will turn off when the engine has started.

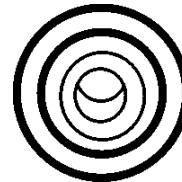

Figure 43. Pre-Heat Lamp

Starting (Manual)

8. Once the engine glow plugs have been warmed, place the **MPEC Control Switch** in the **MANUAL** position to start the engine (Figure 44).

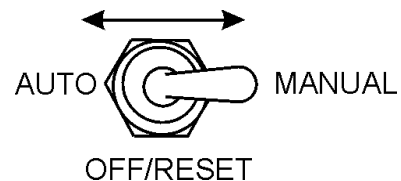

Figure 44. MPEC Control Switch (Manual Position)

9. Once the engine starts, let the engine run for 1-2 minutes. Listen for any abnormal noises. If any abnormalities exist, shutdown the engine and correct the problem.

DCA-70USI (60 Hz) — GENERATOR START-UP PROCEDURE (MANUAL)

10. Verify that the **Engine Running** status LED on the MPEC unit (Figure 45) is **ON** (lit) after the engine has been started.

Figure 45. Engine Running LED (ON)

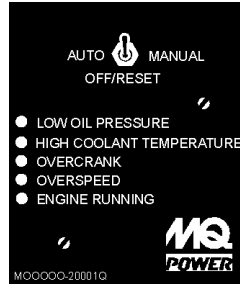

11. The generator's frequency meter (Figure 46) should be displaying the 60 cycle output frequency in **HERTZ**.

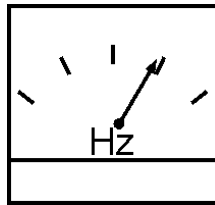

Figure 46. Frequency Meter (Hz)

12. The generator's AC-voltmeter (Figure 47) will display the generator's output in **VOLTS**. If the voltage is not within the specified tolerance, use the voltage adjustment control knob (Figure 48) to increase or decrease the desired voltage.

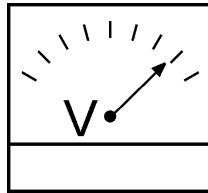

Figure 47. Voltmeter

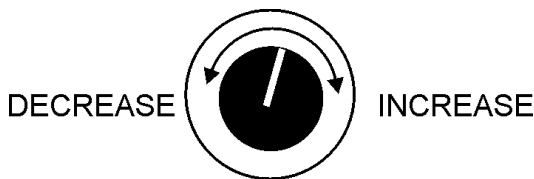

Figure 48. Voltage Adjust Control Knob

13. The ammeter (Figure 49) will indicate **zero amps** with no load applied. When a load is applied, the ammeter will indicate the amount of current that the load is drawing from the generator.

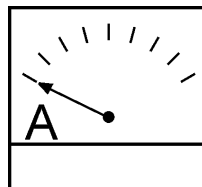

Figure 49. Ammeter (No Load)

14. The engine oil pressure gauge (Figure 50) will indicate the oil pressure (kg/ cm²) of the engine. Under normal operating conditions the oil pressure is approximately 35~65 PSI.

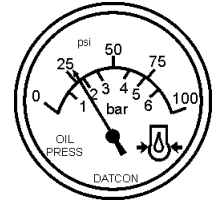

Figure 50. Oil Pressure Gauge

15. The **coolant temperature gauge** (Figure 51) will indicate the coolant temperature. Under normal operating conditions the coolant temperature should be between 165 and 215 degrees Fahrenheit (**Green Zone**).

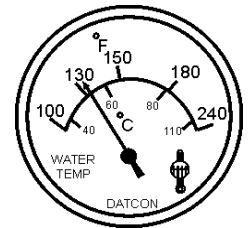

Figure 51. Coolant Temperature Gauge

16. The **tachometer gauge** (Figure 52) will indicate the speed of the engine when the generator is operating. Under normal operating conditions this speed is approximately 1800 RPM's.

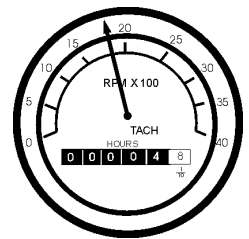

Figure 52. Engine Tachometer Gauge

17. Place the **main**, **GFCI**, and **aux.** circuit breakers in the **ON** position (Figure 53).

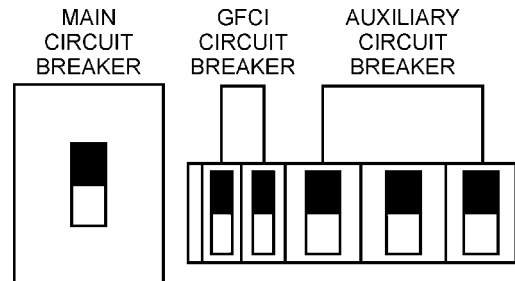

Figure 53. Main, Aux. and GFCI Circuit Breakers (ON)

18. Observe the generator's ammeter (Figure 54) and verify it reads the anticipated amount of current with respect to the load. The ammeter will only display a current reading if a load is in use.

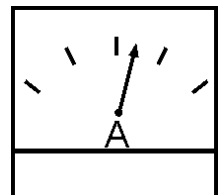

Figure 54. Ammeter (Load)

DCA-70USI (60 Hz) — GENERATOR START-UP PROCEDURE (AUTO MODE)

19. The generator will run until manually stopped or an abnormal condition occurs.

Starting (Auto Mode)

! DANGER - ELECTRICAL SYSTEM HAZARDS

Before connecting this generator to any building's electrical system, a **licensed electrician** must install an **isolation (transfer) switch**. Serious damage to the building's electrical system may occur without this transfer switch.



! CAUTION - BACKUP GENERATOR USE

When connecting the generator to a isolation (transfer) switch, **ALWAYS** have power applied to the generator's internal battery charger. This will ensure that the engine will not fail due to a dead battery.

NOTE

When the generator is set in the **AUTO** mode, the generator will **automatically start** in the event of commercial power falling below a prescribed level by means of a contact closure that is generated automatically by a transfer switch.

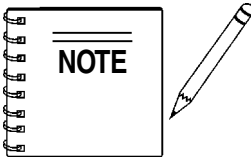

! WARNING - AUTO MODE MAINTENANCE

When running the generator in the **AUTO** mode, remember the generator can start up at any time without warning. **NEVER** attempt to perform any maintenance when the generator is in the auto mode.

1. Perform steps 1 through 5 in the **Before Starting** section as outlined in the **Manual Starting Procedure**.
2. Place the **MPEC Control Switch** (Figure 55) in the **AUTO** position .

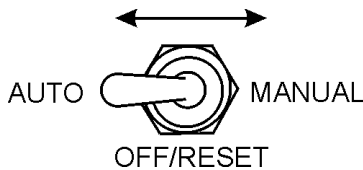
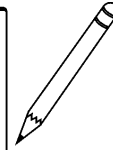
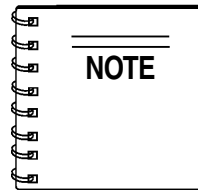

Figure 55. MPEC Control Switch (AUTO)

3. Continue to follow the steps outlined in the **Manual Start-up** procedure (start at step 9).



When the **MPEC Control Switch** is placed in the **AUTO** position, the engine glow plugs will be warmed and the engine will start automatically. The pre-heat lamp will turn off when the engine has started.

! WARNING - SHUTTING DOWN THE GENERATOR

NEVER stop the engine suddenly except in an emergency. **DO NOT** use the emergency stop switch as a method of shutting down the generator. This switch is **ONLY** to be used in the event of an emergency.

Shutdown Procedure

To shutdown the generator use the following procedure:

1. Place both the **MAIN, GFCI** and **LOAD** circuit breakers as shown in Figure 39 to the **OFF** position.
3. Let the engine cool by running it for 3-5 minutes with no load applied.
4. Place the **MPEC Control Switch** (Figure 56) to the **OFF/RESET** position.



Figure 56. MPEC Control Switch (Off/Reset)

5. Verify that the **all** status LED on the MPEC display are **OFF** (not lit).
6. Remove all loads from the generator.

Emergency Shutdown Procedure

1. To shut-down the engine in the event of an emergency, switch the **MAIN, GFCI** and **LOAD** (Figure 39) circuit breakers to **OFF** position.
2. Place the **MPEC Control Switch** switch (Figure 56) to the **OFF/RESET** position.

TABLE 14. INSPECTION/MAINTENANCE		10 Hrs DAILY	250 Hrs	500 Hrs	1000 Hrs
ENGINE	Check Engine Fluid Levels	X			
	Check Air Cleaner	X			
	Check Battery Acid Level	X			
	Check Fan Belt Condition	X			
	Check for Leaks	X			
	Check for Loosening of Parts	X			
	Replace Engine Oil and Filter * 1		X		
	Clean Air Filter		X		
	Check Fuel Filter/Water Separator Bowl	X			
	Clean Unit, Inside and Outside		X		
	Change Fuel Filter			X	
	Clean Radiator and Check Coolant Protection Level*2			X	
	Replace Air Filter Element * 3			X	
	Check all Hoses and Clamps * 4				X
	Clean Inside of Fuel Tank				X
GENERATOR	Measure Insulation Resistance Over 3M ohms		X		
	Check Rotor Rear Support Bearing			X	

*1 Replace engine oil and filter at 100 hours, first time only.

*2 Add "Supplemental Coolant Additives (SCA'S)" to recharge the engine coolant.

*3 Replace primary air filter element when restriction indicator shows a vacuum of 625 mm (25 in. H₂O).

*4 If blowby hose needs to be replaced, ensure that the slope of the blowby hose is at least a 1/2 inch per foot, with no sags or dips that could collect moisture and/or oil.

General Inspection

Prior to each use, the generator should be cleaned and inspected for deficiencies. Check for loose, missing or damaged nuts, bolts or other fasteners. Also check for fuel, oil, and coolant leaks. Use Table 14 as a general maintenance guideline **Engine Side** (Refer to the Engine Instruction Manual)

Air Cleaner

Every 250 hours: Remove air cleaner element and clean the heavy duty paper element with light spray of compressed air. Replace the air cleaner as needed.

Air Cleaner with Dust Indicator

This indicator is attached to the air cleaner. When the air cleaner element is clogged, air intake restriction becomes greater and the dust indicator signal shows **RED** meaning the element needs changing or service. After changing the air element, press the dust indicator button to reset the indicator.

Service Daily

If the engine is operating in very **dusty** or **dry grass** conditions, a clogged air cleaner will result. This can lead to a loss of power, excessive carbon buildup in the combustion chamber and high fuel consumption. Change air cleaner more **frequently** if these conditions exist.

Fuel Addition

Add diesel fuel (the grade may vary according to season and locations).

Removing Water from the Fuel Tank

After prolonged use, water and other impurities accumulate in the bottom of the tank. Occasionally inspect the fuel tank for water contamination and drain the contents if required.

During cold weather, the more empty volume inside the tank, the easier it is for water to condense. This can be reduced by keeping the tank full with diesel fuel.

Air Removal

If air enters the fuel injection system of a diesel engine, starting becomes impossible. After running out of fuel, or after disassembling the fuel system, bleed the system according to the following procedure. See the *ISUZU Engine Manual* for details.

To restart after running out of fuel, turn the switch to the “ON” position for 15-30 seconds. Try again, if needed. This unit is equipped with an automatic air bleeding system.

Check Oil Level

Check the crankcase oil level prior to each use, or when the fuel tank is filled. Insufficient oil may cause severe damage to the engine. Make sure the generator is level. The oil level must be between the two notches on the dipstick as shown in Figure 31.

Replacing Oil Filter

- Remove the old oil filter.
- Apply a film of oil to the gasket on the new oil filter.
- Install the new oil filter.
- After the oil cartridge has been replaced, the engine oil will drop slightly. Run the engine for a while and check for leaks before adding more oil if needed. Clean excessive oil from engine.

Cleaning the Fuel Strainer

Clean the fuel strainer if it contains dust or water. Remove dust or water in the strainer cap and wash it in gasoline. Securely fasten the fuel strainer cap so that fuel will not leak. Check the fuel strainer every 200 hours of operation or once a month.

Replacing Fuel Filter

- Replace the fuel filter cartridge with new one every 500 hours or so.
- Loosen the drain plug at the lower top of the fuel filter. Drain the fuel in the fuel body together with the mixed water. **DO NOT** spill the fuel during disassembly.
- Vent any air.

Flushing Out Radiator and Replacing Coolant

- Open both cocks located at the crankcase side and at the lower part of the radiator and drain coolant. Open the radiator cap while draining. Remove the overflow tank and drain.
- Check hoses for softening and kinks. Check clamps for signs of leakage.
- Flush the radiator by running clean tap water through radiator until signs of rust and dirt are removed. **DO NOT** clean radiator core with any objects, such as a screwdriver.
- Tighten both cocks and replace the overflow tank.
- Replace with coolant as recommended by the engine manufacturer.
- Close radiator cap tightly.

WARNING - BURN HAZARDS

Allow engine to **cool** when flushing out radiator. Flushing the radiator while hot could cause serious burns from water or steam.



Generator Storage

For long term storage of the generator the following is recommended:

- Fill the fuel tank completely. Treat with a fuel stabilizer if necessary.
- Completely drain the oil from the crankcase and refill if necessary with fresh oil.
- Clean the entire generator, internal and external.
- Cover the generating set and store in a clean, dry place.
- Disconnect the battery.
- Make sure engine coolant is at proper level.
- If generator is mounted on a trailer, jack trailer up and place on blocks so tires do not touch the ground or block and completely remove the tires.

Jacket Water Heater and Internal Battery Charger 120 VAC Input Receptacles (OPTIONAL)

This generator can be optionally equipped with two 120 VAC, 20 amp input receptacles located on the output terminal panel.

The purpose of these receptacles is to provide power via commercial power to the *jacket water heater* and *internal battery charger*.

These receptacles will **ONLY** function when commercial power has been supplied to them (Figure 57). To apply commercial power to these receptacles, a power cord of adequate size will be required (See Table 6).

When using the generator in *hot* climates there is no reason to apply power to jacket water heater. However, if the generator will be used in *cold* climates it is always a good idea to apply power to the jacket water heater at all times. To apply power to the jacket water heater simply apply power to the jacket water heater receptacle via commercial power using an power cord of adequate size.

If the generator will be used daily, the battery should normally not require charging. If the generator will be idle (not used) for long periods of time, apply power to the battery charger receptacle via commercial power using an power cord of adequate size.

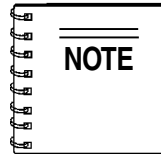

To ensure adequate starting capability, **always** have power applied to the generator's *internal battery charger*.

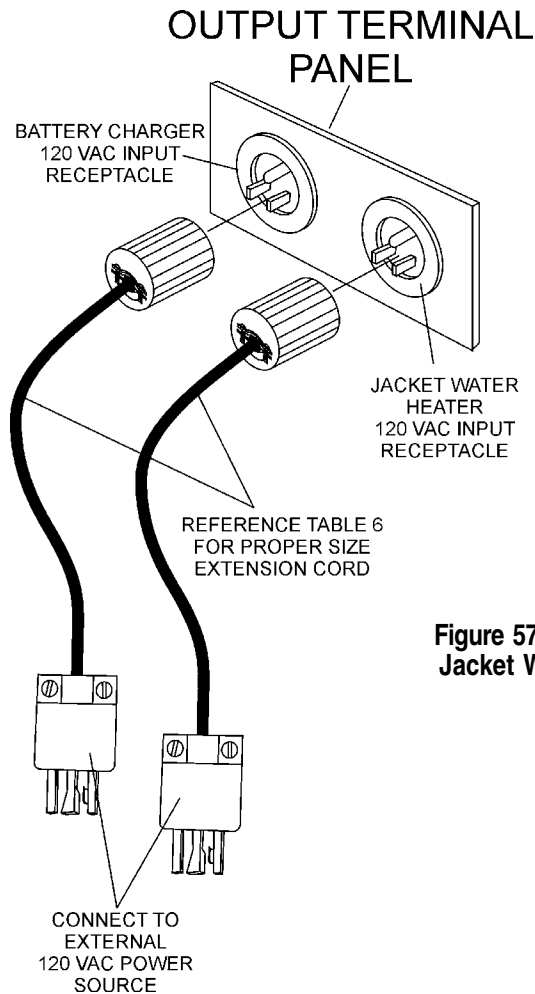

Figure 57. DCA-45SIU2 Battery Charger & Jacket Water Heater Power Connections

Trailer Maintenance

This section is intended to provide the user with generic trailer service and maintenance information. The service and maintenance guidelines referenced in this section refer to a wide range of trailers.

Remember periodic inspection of the trailer will ensure safe towing of the generator and will prevent personal injury and damage to the equipment.

The definitions below describe some of the major components of a typical trailer that would be used with the DCA-70USI Ultra Silent™ Generator.

1. **Fuel Cell** - Provides an adequate amount of fuel for the equipment in use. Fuel cells must be empty when transporting equipment.
2. **Braking System** - System employed in stopping the trailer. Typical braking systems are electric, surge, hydraulic, hydraulic-surge and air.
3. **GVWR**- Gross Vehicle Weight Rating (GVWR) is the maximum number of pounds the trailer can carry, including the fuel cell (empty).
4. **Frame Length** - Measurement is from the ball hitch to the rear bumper (reflector).
5. **Frame Width** - Measurement is from fender to fender
6. **Jack Stand** - Trailer support device with maximum pound requirement from the tongue of the trailer.
7. **Coupler** - Type of hitch used on the trailer for towing.
7. **Coupler** - Type of hitch used on the trailer for towing.
8. **Tire Size** - Indicates the diameter of the tire in inches (10,12,14, etc.), and the width in millimeters (175,185,205, etc.). The tire diameter must match the diameter of the tire rim.
9. **Tire Ply** - The tire ply (layers) number is rated in letters; 2-ply,4-ply,6-ply, etc.
10. **Wheel Hub** - The wheel hub is connected to the trailer's axle.
11. **Tire Rim** - Tires mounted on a tire rim. The tire rim must match the size of the tire.
12. **Lug Nuts** - Used to secure the wheel to the wheel hub. Always use a torque wrench to tighten down the lug nuts. See Table 16 and Figure 59 for lug nut tightening and sequence.
13. **Axle** - Indicates the maximum weight the axle can support in pounds, and the diameter of the axle expressed in inches. Please note that some trailers have a double axle. This will be shown as 2-6000 lbs., meaning two axles with a total weight capacity of 6000 pounds.
14. **Suspension** - Protects the trailer chassis from shocks transmitted through the wheels. Types of suspension used are leaf, Q-flex, and air ride.
15. **Electrical** - Electrical connectors (looms) are provided with the trailer so the brake lights and turn signals can be connected to the towing vehicle.
16. **Application** - Indicates which units can be employed on a particular trailer.

Brakes

Trailer brakes should be inspected the **first 200 miles** of operation. This will allow the brake shoes and drums to seat properly. After the first 200 mile interval, inspect the brakes **every 3,000 miles**. If driving over rough terrain, inspect the brakes more frequently.

Figure 58 displays the major hydraulic surge brake components that will require inspection and maintenance. Please inspect these components as required using steps 1 through 8 and Table 15 as listed below:

Brake Adjustment

1. Place the trailer on jack stands. Make sure the jack stands are placed on secure level ground.
2. Check the wheel and drum for free rotation.
3. Remove the adjusting hole cover from the adjusting slot at the bottom brake backing plate.
4. With a screwdriver or standard adjusting tool, rotate the star wheel of the adjuster assembly to expand the brake shoes.
5. Adjust the brake shoes outward until the pressure of the lining against the wheel drum makes the wheel difficult to turn.
6. Adjust, rotate the star wheel in the opposite direction until the wheel rotates freely with slight lining drag.
7. Replace the adjusting hole cover and lower the trailer to the ground.
8. Repeat steps 1 through 7 on the remaining brakes.

Hydraulic Surge Brakes

Hydraulic surge brakes (Figure 58) should not require any special attention with the exception of routine maintenance such as shoe and lining replacement. Brake lines should be periodically checked for cracks, kinks, or blockage.

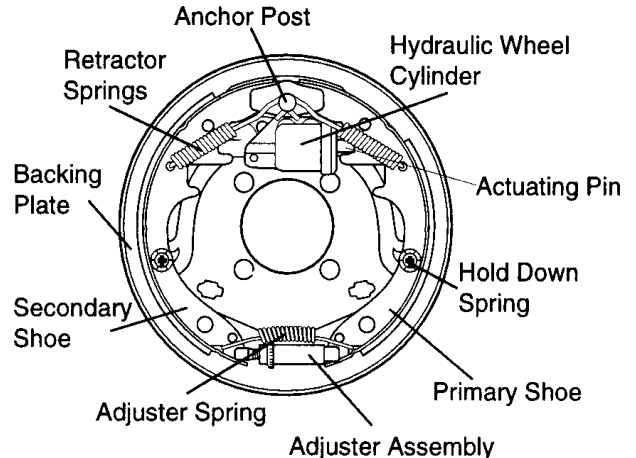

Figure 58. Hydraulic Brake Components

Actuator

Hydraulic surge braking requires the installation of an actuator at the tongue of the trailer. Remember the **surge** or **push** of the trailer toward the tow vehicle automatically synchronizes the trailer brakes with the tow vehicle brakes. As the trailer pushes against the tow vehicle the actuator telescopes together and applies force to the master cylinder, supplying hydraulic pressure to the trailer brakes.

Periodically check and test the surge “**actuator**” to make sure that it is functioning correctly. Never use an undersize actuator.

Table 15. Hydraulic Brake Troubleshooting

Symptom	Possible Cause	Solution
No Brakes	Brake line broken or kinked?	Repair or replace.
Weak Brakes or Brakes Pull to One Side	Brake lining glazed?	Reburnish or replace.
	Trailer overloaded?	Correct weight.
	Brake drums scored or grooved?	Machine or replace.
	Tire pressure correct?	Inflate all tires equally.
	Tires unmatched on the same axle?	Match tires.
Locking Brakes	Brake components loose, bent or broken?	Replace components.
	Brake drums out-of-round?	Replace.
Noisy Brakes	System lubricated?	Lubricate.
	Brake components correct?	Replace and correct.
Dragging Brakes	Brake lining thickness incorrect or not adjusted correctly?	Install new shoes and linings.
	Enough brake fluid or correct fluid?	Replace rubber parts fill with dot 4 fluid.

DCA-70USI (60 Hz) — TRAILER MAINTENANCE

Tires/Wheels/Lug Nuts

Tires and wheels are a very important and critical components of the trailer. When specifying or replacing the trailer wheels it is important the wheels, tires, and axle are properly matched.

! CAUTION - EYESIGHT HAZARD

ALWAYS wear safety glasses when removing or installing force fitted parts. Failure to comply may result in serious injury.



! CAUTION - REPAIRING TRAILER WHEELS



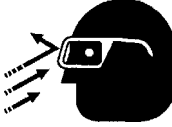



DO NOT attempt to repair or modify a wheel. **DO NOT** install in inner tube to correct a leak through the rim. If the rim is cracked, the air pressure in the inner tube may cause pieces of the rim to explode (break off) with great force and cause serious eye or bodily injury.



Tire Wear/Inflation

Tire inflation pressure is the most important factor in tire life. Pressure should be checked cold before operation **DO NOT** bleed air from tires when they are **hot!** Check inflation pressure weekly during use to insure the maximum tire life and tread wear.

Table 16 (Tire Wear Troubleshooting) will help pinpoint the causes and solutions of tire wear problems.

TABLE 16. TIRE WEAR TROUBLESHOOTING			
WEAR PATTERN		CAUSE	SOLUTION
	Center Wear	Over Inflation.	Adjust pressure to particular load per tire manufacturer.
	Edge Wear	Under Inflation.	Adjust pressure to particular load per tire manufacturer.
	Side Wear	Loss of camber or overloading.	Make sure load does not exceed axle rating. Align wheels.
	Toe Wear	Incorrect toe-in.	Align wheels.
	Cupping	Out-of-balance.	Check bearing adjustment and balance tires.
	Flat Spots	Wheel lockup & tire skidding.	Avoid sudden stops when possible and adjust brakes.

Suspension

The **leaf suspension** springs and associated components (Figure 59) should be visually inspected every 6,000 miles for signs of excessive wear, elongation of bolt holes, and loosening of fasteners. Replace all damaged parts (suspension) immediately. Torqued suspension components as detailed in Table 17.

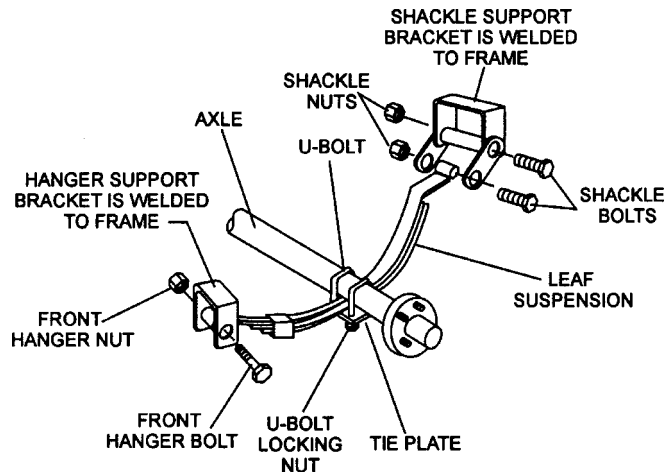

Figure 59. Major Suspension Components

Table 17. Suspension Torque Requirements

Item	Torque (Ft.-Lbs.)
3/8" U-BOLT	MIN-30 MAX-35
7/16" U-BOLT	MIN-45 MAX-60
1/2" U-BOLT	MIN-45 MAX-60
SHACKLE BOLT SPRING EYE BOLT	SNUG FIT ONLY. PARTS MUST ROTATE FREELY. LOCKING NUTS OR COTTER PINS ARE PROVIDED TO RETAIN NUT-BOLT ASSEMBLY.
SHOULDER TYPE SHACKLE BOLT	MIN-30 MAX-50

DCA-70USI (60 Hz) — TRAILER MAINTENANCE

Lug Nut Torque Requirements

It is extremely important to apply and maintain proper wheel mounting torque on the trailer. Be sure to use only the fasteners matched to the cone angle of the wheel. Proper procedure for attachment of the wheels is as follows:

1. Start all wheel lug nuts by hand.
2. Torque all lug nuts in sequence (see Figure 60). **DO NOT** torque the wheel lug nuts all the way down. Tighten each lug nut in 3 separate passes as defined by Table 18.
3. After first road use, retorque all lug nuts in sequence. Check all wheel lug nuts periodically.

Table 18. Tire Torque Requirements

Wheel Size	First Pass FT-LBS	Second Pass FT-LBS	Third Pass FT-LBS
12"	20-25	35-40	50-65
13"	20-25	35-40	50-65
14"	20-25	50-60	90-120
15"	20-25	50-60	90-120
16"	20-25	50-60	90-120

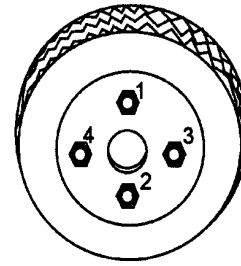

4-LUG NUTS

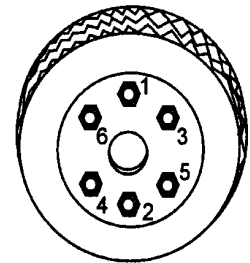

6-LUG NUTS

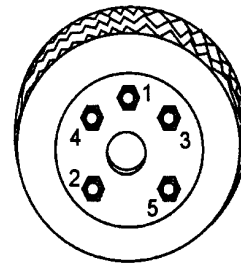

5-LUG NUTS

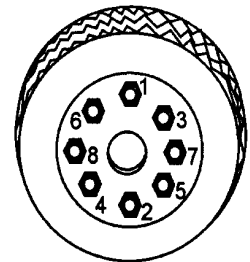

8-LUG NUTS

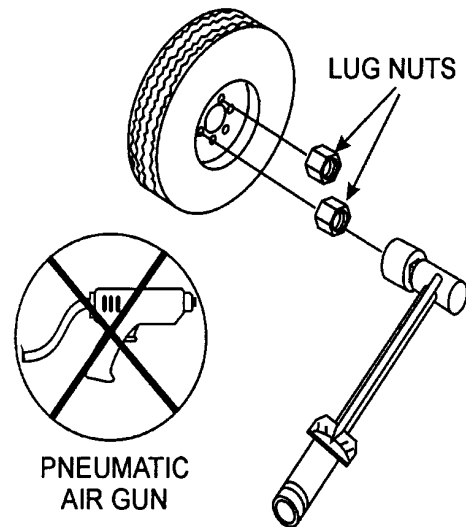

PNEUMATIC
AIR GUN

TORQUE WRENCH

Figure 60. Wheel Lug Nuts
Tightening Sequence

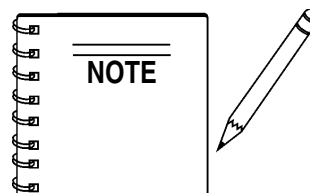

NEVER use an pneumatic air gun to tighten wheel lug nuts.

DCA-70USI (60 Hz) — TRAILER WIRING DIAGRAM

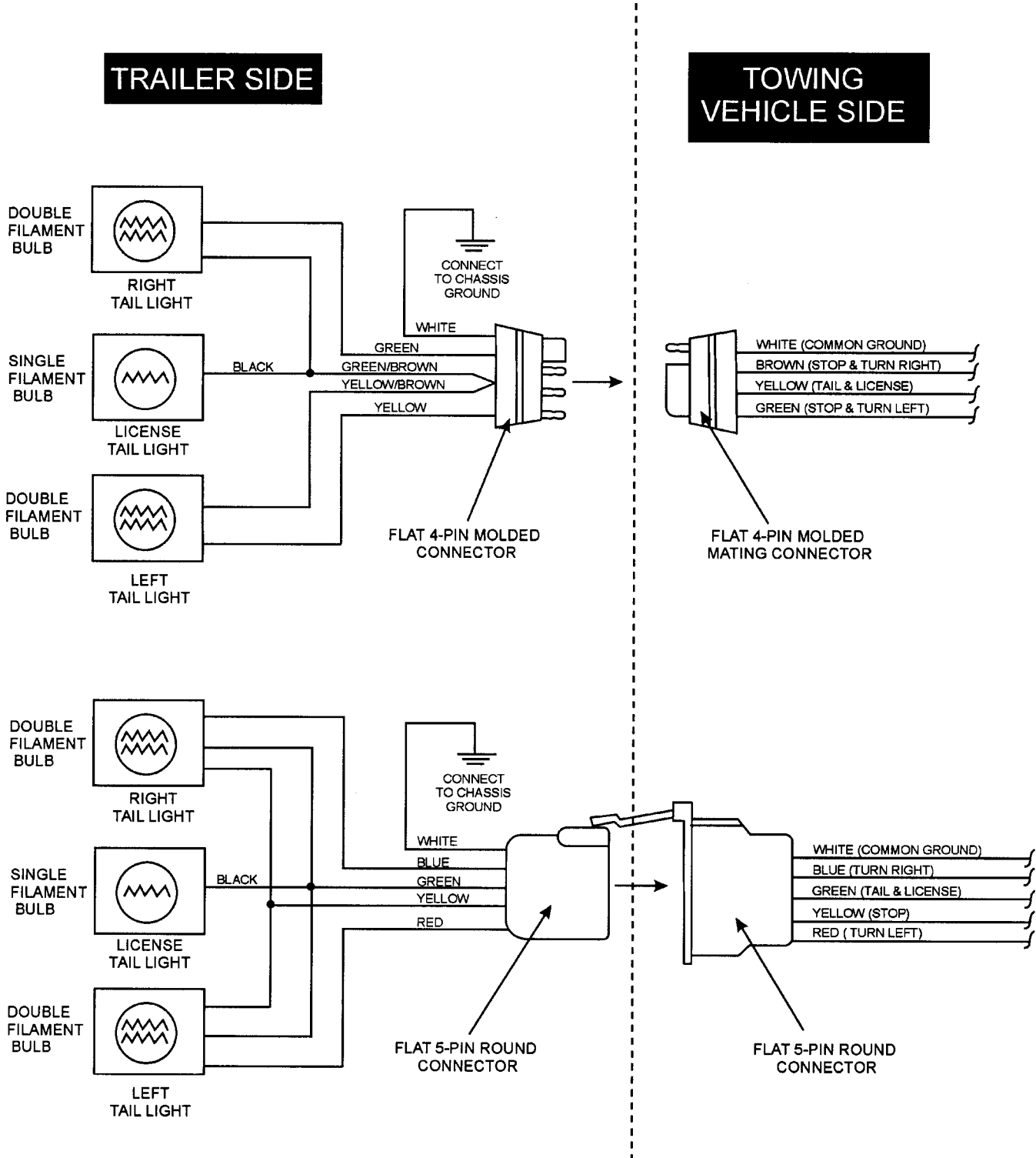
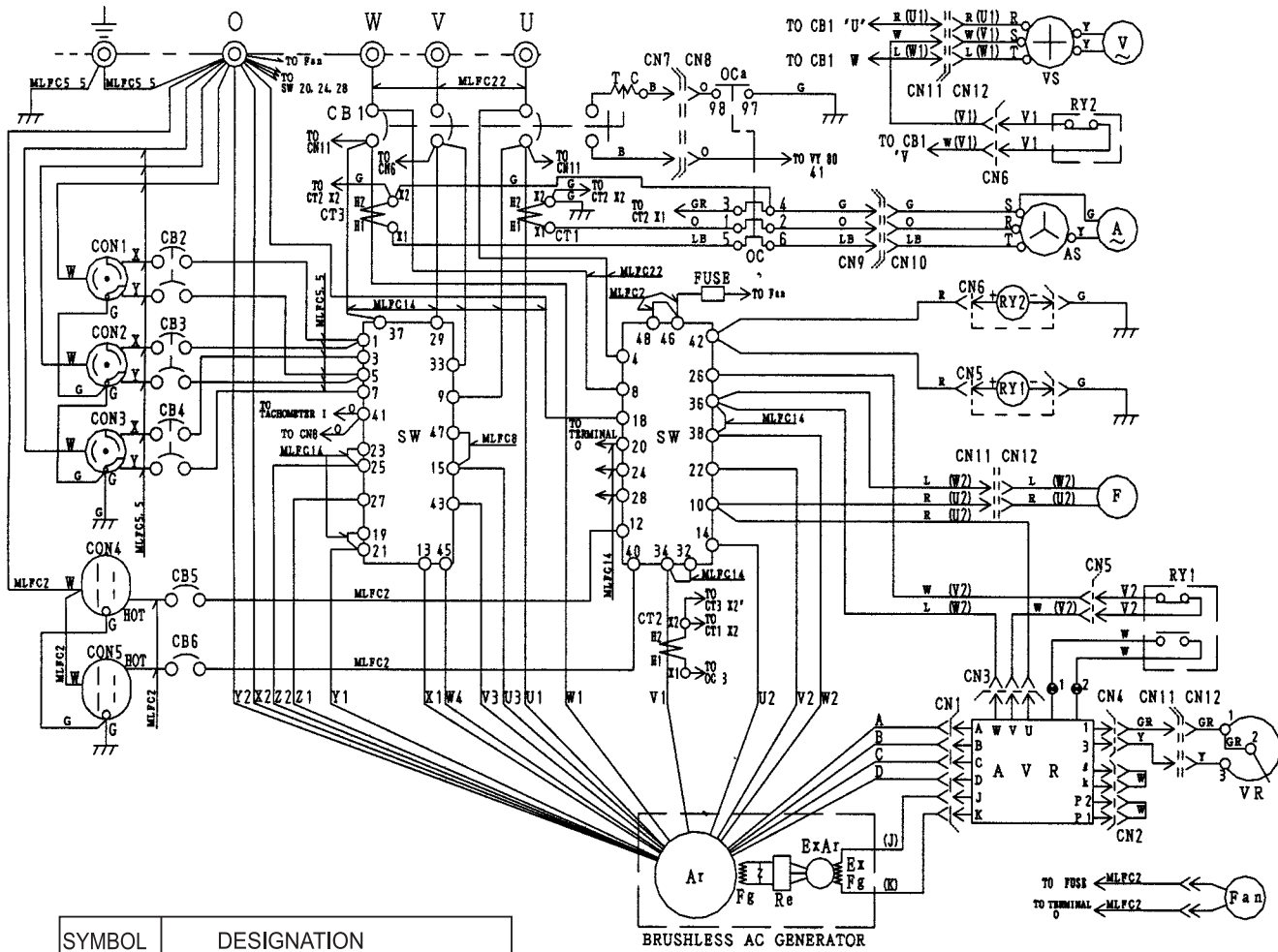

Figure 61. Trailer/Towing Vehicle Wiring Diagram

DCA-70USI (60 Hz) — GENERATOR WIRING DIAGRAM



SYMBOL	DESIGNATION
Ar	MAIN GENERATOR ARMATURE WINDING
Fg	MAIN GENERATOR FIELD WINDING
ExAr	EXCITER ARMATURE WINDING
ExFg	EXCITER FIELD WINDING
Re	RECTIFIER
AVR	AUTOMATIC VOLTAGE REGULATOR
VR	VOLTAGE REGULATOR (RHEOSTAT)
CT 1,2,3	CURRENT TRANSFORMER
AS	CHANGE-OVER SWITCH, AMMETER
A	AC. AMMETER
VS	CHANGE-OVER SWITCH, VOLTMETER
V	AC. VOLTMETER
F	FREQUENCY METER
CB1	CIRCUIT BREAKER
CB2,3,4	CIRCUIT BREAKER
CB5,6	CIRCUIT BREAKER
CON1,2,3	RECEPTACLE
CON4,5	RECEPTACLE
OC	OVER CURRENT RELAY
SW	SELECTOR SWITCH
RY1,2	RELAY UNIT
FUSE	15A
FAN	FAN MOTOR

CONNECTOR ARRANGEMENT (WIRING VIEW)

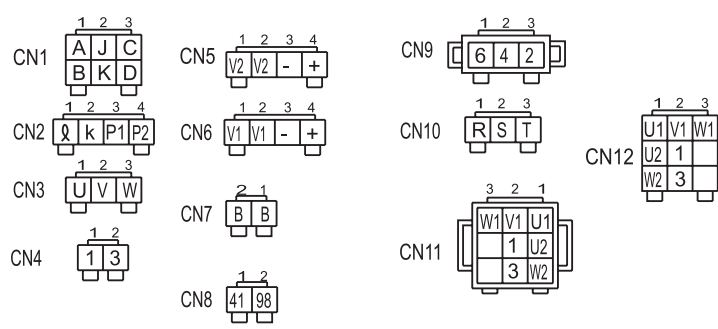

Figure 62. Generator Wiring Diagram

DCA-70USI (60 Hz) — ENGINE WIRING DIAGRAM

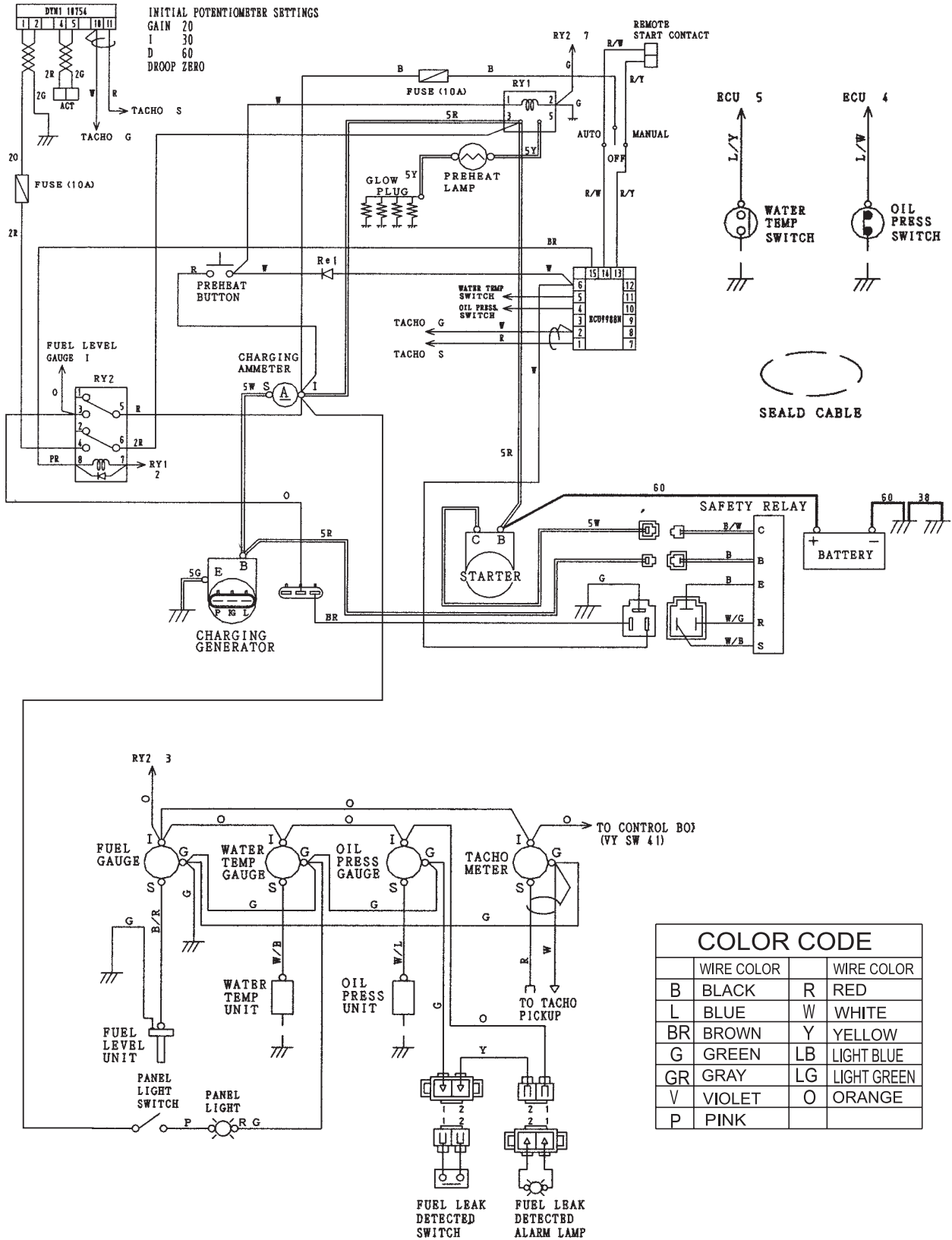

Figure 63. Engine Wiring Diagram

DCA-70USI (60 Hz) — TROUBLESHOOTING (GENERATOR)

Practically all breakdowns can be prevented by proper handling and maintenance inspections, but in the event of a breakdown, use Table 19 shown below for diagnosis of the Generator. If the problem cannot be remedied, consult our company's business office or service plant.

TABLE 19. GENERATOR TROUBLESHOOTING

SYMPTOM	POSSIBLE PROBLEM	SOLUTION
No Voltage Output	AC Voltmeter defective?	Check output voltage using a voltmeter.
	Is wiring connection loose?	Check wiring and repair.
	Is AVR defective?	Replace if necessary.
	Defective Rotating Rectifier?	Check and replace.
	Defective Exciter Field?	Check for 17.3 ohms across J & K on CN1
Low Voltage Output	Is engine speed correct?	Turn engine throttle lever to "High".
	Is wiring connections loose?	Check wiring and repair.
	Defective AVR?	Replace if necessary.
High Voltage Output	Is wiring connections loose?	Check wiring and repair.
	Defective AVR?	Replace if necessary.
Circuit Breaker Tripped	Short Circuit in load?	Check load and repair.
	Over current?	Confirm load requirements and reduce.
	Defective circuit breaker?	Check and replace.
	Over current Relay actuated?	Confirm load requirement and replace.

DCA-70USI (60 Hz) — TROUBLESHOOTING (ENGINE CONTROLLER)

Practically all breakdowns can be prevented by proper handling and maintenance inspections, but in the event of a breakdown, use Table 20 (Engine Controller Troubleshooting) as a basic guideline for troubleshooting the Microprocessor Engine Controller unit (MPEC). If the problem cannot be remedied, consult our company's business office or service plant.

TABLE 20. ENGINE CONTROLLER TROUBLESHOOTING (MPEC)

SYMPTOM	POSSIBLE PROBLEM	SOLUTION
Low oil pressure light is on.	Low oil level?	Fill oil level.
	Oil pressure sending unit failure?	Replace oil pressure sending unit.
	Time delay malfunction in Controller?	Refer to dealer.
	Wire shorted?	Inspect/repair wire.
Low coolant level light is on. (Optionally Installed)	Low coolant level?	Fill coolant level.
	Sending unit failure?	Replace sending unit.
	Low battery voltage?	Replace/charge battery.
High coolant temperature light is on.	Fan belt tension incorrect?	Tighten/replace fan belt.
	Air flow is not circulation through radiator?	Clean/repair radiator grill.
	Doors open?	Close doors.
	Exhaust leaking?	Replace/repair gaskets or faulty part.
	Generator being overloaded?	Check/reduce load.
	Thermostat failure?	Replace thermostat.
	Air intake blocked?	Clear all air intakes.
Overcrank light is on.	Temperature switch failure?	Replace temperature switch.
	No or low Fuel?	Fill fuel level.
Overspeed light is on.	Controller needs to be calibrated?	Refer to dealer.
	RPM engine speed too high?	Adjust RPM.
	Governor actuator needs to be adjusted?	Adjust governor actuator.
	Governor controller needs to be adjusted?	Adjust governor controller.
Loss of MPU light(s) or on.	Engine Controller needs to be calibrated?	Refer to dealer.
	Magnetic pick up out of adjustment?	Adjust magnetic pick up.
	Magnetic pick up dirty?	Clean magnetic pick up.

EXPLANATION OF CODE IN REMARKS COLUMN

How to read the marks and remarks used in this parts book.

Items Found In the “Remarks” Column

Serial Numbers-Where indicated, this indicates a serial number range (inclusive) where a particular part is used.

Model Number-Where indicated, this shows that the corresponding part is utilized only with this specific model number or model number variant.

Items Found In the “Items Number” Column

All parts with same symbol in the number column, *, #, +, %, or <, belong to the same assembly or kit.

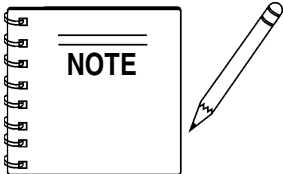

If more than one of the same reference number is listed, the last one listed indicates newest (or latest) part available.

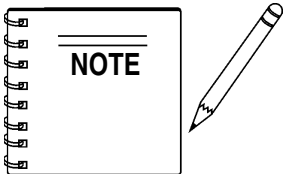

The contents of this catalog are subject to change without notice.

DCA-70USI (60 Hz) — SUGGESTED SPARE PARTS

DCA-70USI (60 Hz) WHISPER WATT GENERATOR W/ISUZU FF4BG1T DIESEL ENGINE 1 TO 3 UNITS

<u>Qty.</u>	<u>P/N</u>	<u>Description</u>
5	1132402311	FILTER, OIL
5	1132400791	FILTER, FUEL, PRIMARY
3	0602046365	ELEMENT, AIR
1	8972333820	BELT, FAN
1	0605505070	CAP. FUEL TANK
1	0602122272	UNIT, OIL PRESSURE
1	0602123260	UNIT, WATER TEMPERATURE
2	0601802149	FUSE, 10A
1	8971256000	SENDER, WATER SWITCH (ENGINE SIDE)
1	9827200690	SENDER, OIL SWITCH (ENGINE SIDE)
1	0605501079	SENDER, FUEL SWITCH

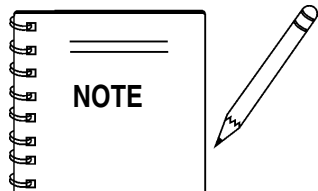

Part number on this Suggested Spare Parts list may supercede/replace the P/N shown in the text pages of this book.

DCA-70USI (60 HZ) — GENERATOR ASSY.

GENERATOR ASSY.

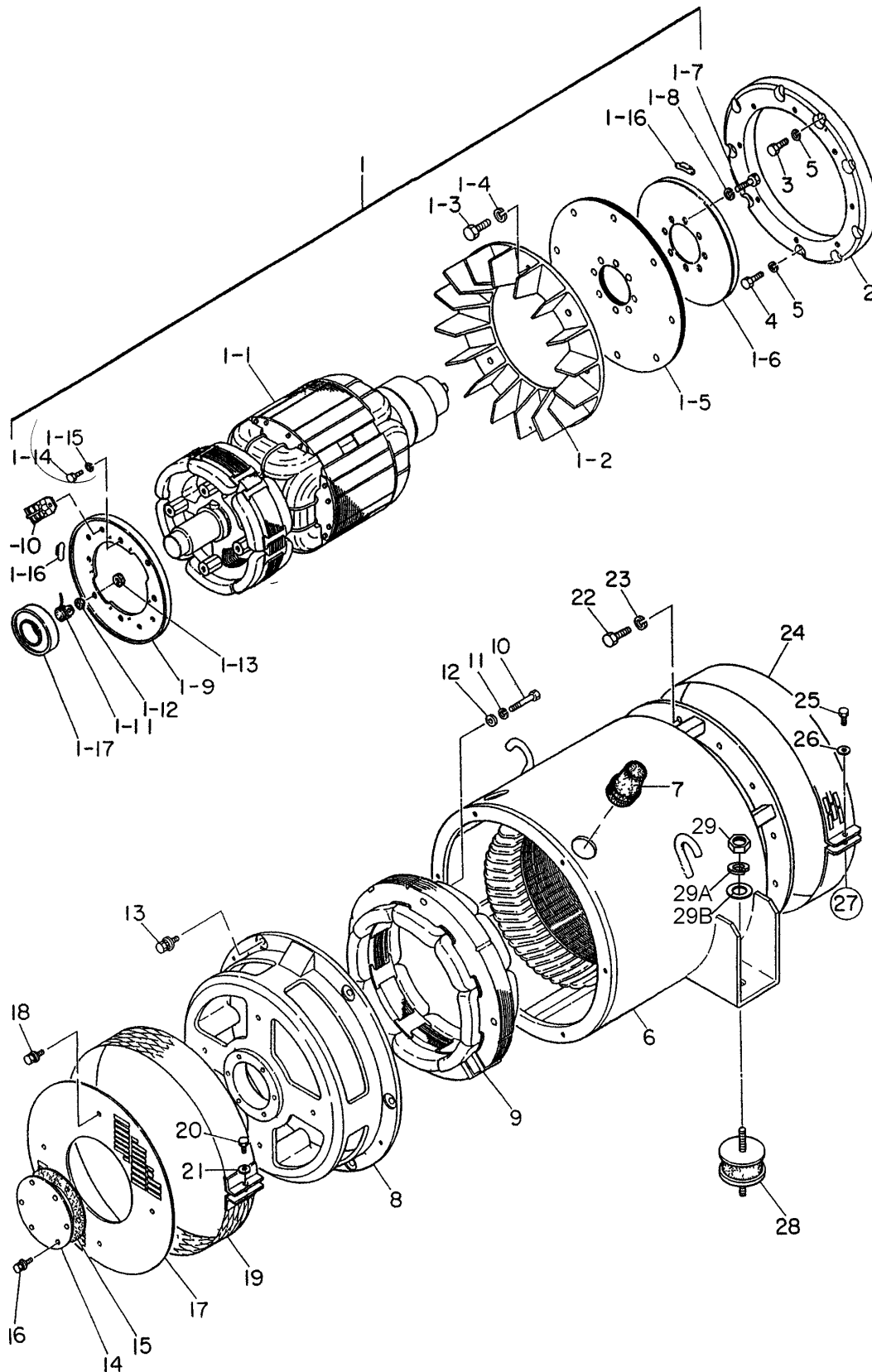

DCA-70USI (60 Hz) — GENERATOR ASSY.

GENERATOR ASSY.

<u>NO.</u>	<u>PART NO.</u>	<u>PART NAME</u>	<u>QTY.</u>	<u>REMARKS</u>
1	B5110000102	ROTOR ASSY.	1	INCLUDES ITEMS W/*
1-1*		FIELD ASSY.	1	
1-2*	8101070033	FAN	1	
1-3*	0010310035	HEX HEAD BOLT	8	
1-4*	0042510000	SPRING WASHER	8	
1-5*	8101611004	COUPLING DISK	5	
1-6*	8101015003	BALANCING PLATE	1	PURCHASE SET OF 1-16
1-7*	0012110030	HEX HEAD BOLT	8	S=26
1-8*	0042510000	SPRING WASHER	8	
1-9*	8101026013	SET PLATE, RECTIFIER	1	PURCHASE SET OF 1-16
1-10*	0601821349	RECTIFIER	2	PT3610
1-11*	0601822601	SURGE ABSORBER	1	ERZ-M14JK621A
1-12*	8001020004	INSULATOR WASHER	1	
1-13*	8001020504	INSULATOR WASHER	1	
1-14*	0010110020	HEX HEAD BOLT	4	
1-15*	0040010000	SPRING WASHER	4	
1-16*	0601000209	BALANCING WEIGHT KIT	1	
1-17*	0071906311	BEARING	1	6311DDU C3
2	M2163400103	COUPLING RING	1	
3	M9200100204	REAMER BOLT	2	
4	0010310030	HEX HEAD BOLT	7	
5	0042510000	SPRING WASHER	9	
6	B5130000103	STATOR ASSY	1	B5134000304
7	0845041904	GROMMET	2	
8	8191315292	END BRACKET	1	
9	8101350013	FIELD ASSY EXCITER	1	B5134000304
10	0012110070	HEX HEAD BOLT	4	S=26
11	0042610000	SPRING WASHER	4	
12	0041210000	PLAIN WASHER	4	
13	0017110035	HEX HEAD BOLT	6	
14	8101312014	COVER, BEARING	1	
15	8131312014	GASKET, BEARING	1	
16	0016906016	HEX HEAD BOLT	4	
17	8101331003	COVER, END BRACKET	1	
18	0016906016	HEX HEAD BOLT	4	
19	8101333003	COVER, END BRACKET	1	
20	0340406040	HEX HEAD BOLT	1	
21	0041606000	PLAIN WASHER	1	
22	0010110030	HEX HEAD BOLT	12	
23	0042510000	SPRING WASHER	12	
24	8111332014	COVER, FAN	1	
25	0340406040	HEX HEAD BOLT	1	
26	0041606000	PLAIN WASHER	1	
27	0600815000	NUT	1	
28	0605000010	RUBBER SUSPENSION	2	
29	0030012000	HEX NUT	2	
29A	0040012000	SPRING WASHER	2	
29B	0041212000	PLAIN WASHER	2	

DCA-70USI (60 Hz) — CONTROL BOX ASSY.

CONTROL BOX ASSY.

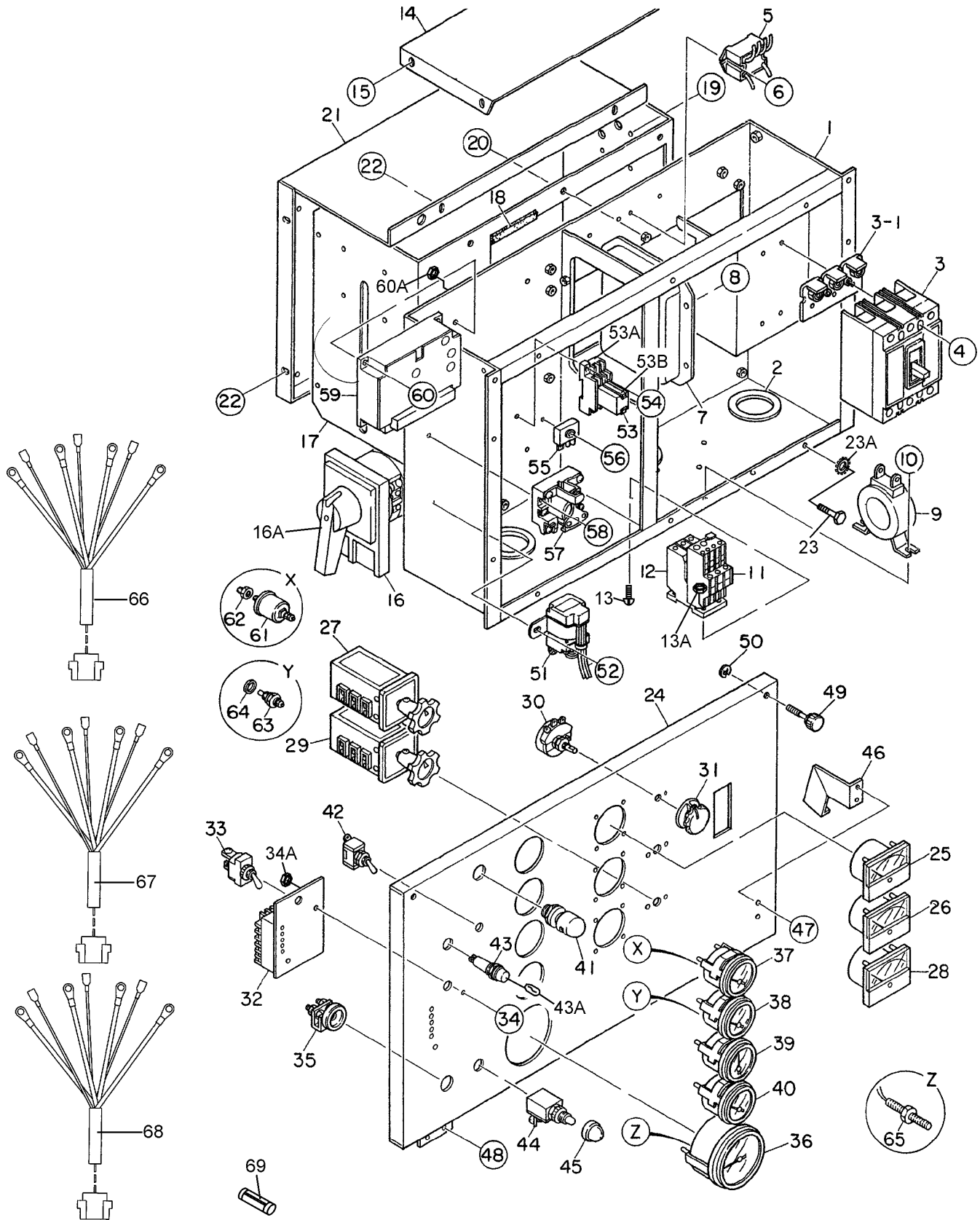

DCA-70USI (60 Hz) — CONTROL BOX ASSY.

CONTROL BOX ASSY.

<u>NO.</u>	<u>PART NO.</u>	<u>PART NAME</u>	<u>QTY.</u>	<u>REMARKS</u>
1	M2213001102	CONTROL BOX	1	
2	0330000180	EDGING	3	
3	0601870432	CIRCUIT BREAKER, 175 A	1	
3-1	0601870490	COVER, CIRCUIT BREAKER	2	
4	0021004040	MACHINE SCREW	4	
5	0601823863	RELAY UNIT	2	
6	0027104016	MACHINE SCREW	4	
7	0601820671	AUTOMATIC VOLTAGE REGULATOR	1	
8	0027105016	MACHINE SCREW	4	
9	0601806139	CURRENT TRANSFORMER, 150/5A	3	
10	0027106016	MACHINE SCREW	6	
11	0601820847	OVER CURRENT RELAY	1	
12	0601820848	OVER CURRENT RELAY	1	
13	0027104016	MACHINE SCREW	2	
13A	0207004000	HEX NUT	2	
14	M2213500203	CONTROL BOX COVER	1	
15	0016906016	HEX HEAD BOLT	4	
16	M2270100004	SELECTOR SWITCH	1	
16A	M1201000004	KNOB, SELECTOR SWITCH		
17	M2213600803	SWITCH BRACKET	1	
18	0330000320	EDGING	2	
19	0027104010	MACHINE SCREW	4	
20	0016906016	HEX HEAD BOLT	6	
21	M2213600904	SWITCH COVER	1	
22	0016906016	HEX HEAD BOLT	4	
23	0015906016	HEX HEAD BOLT	8	
23A	0040506000	TOOTHED WASHER	1	
24	M2223000703	CONTROL PANEL	1	
25	0601807641	FREQUENCY METER, 45~65Hz 240V	1	
26	0601808987	AC AMMETER, 0~150A/300A:5A	1	
27	0601801040	CHANGE-OVER SWITCH, AMMETER	1	
28	0601806859	AC VOLTMETER, 0~600V	1	
29	0601801041	CHANGE-OVER SWITCH, VOLTMETER	1	
30	0601840073	RHEOSTAT(VOLTAGE REGULATOR)	1 2W 1k OHM
31	0601840121	KNOB	1	
32	0602202593	CONTROLLER, 60 Hz	1	
33	0601831340	SWITCH	1	
34	0027104040	MACHINE SCREW	2	
34A	0207004000	HEX NUT	2	
35	8941739480	CONTROL RESISTANCE	1 REPLACES P/N 0602202506
36	0602120095	TACHOMETER	1	

DCA-70USI (60 Hz) — CONTROL BOX ASSY. (CONT.)

CONTROL BOX ASSY.

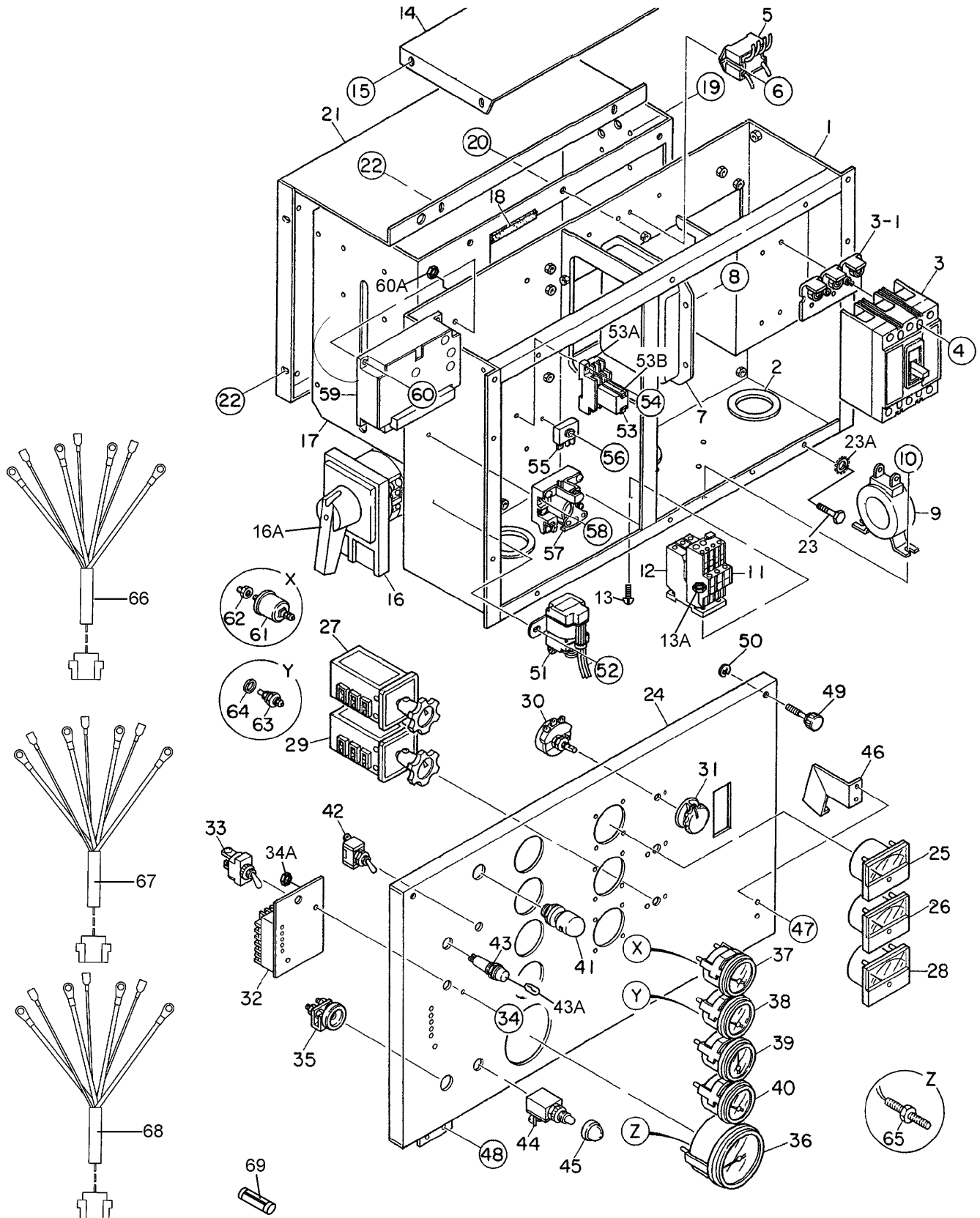

DCA-70USI (60 Hz) — CONTROL BOX ASSY. (CONT.)

CONTROL BOX ASSY.

<u>NO.</u>	<u>PART NO.</u>	<u>PART NAME</u>	<u>QTY.</u>	<u>REMARKS</u>
37	0602122093	OIL PRESSURE GAUGE	1	
38	0602123090	WATER TEMPERATURE GAUGE	1	
39	0602121080	CHARGING AMMETER	1	
40	0602125090	FUEL GAUGE	1	
41	0601810141	PANEL LIGHT	1	
42	0601831330	SWITCH, PANEL LIGHT	1	
43	0602103092	ALARM LAMP	1	
43A	0601810245	BULB, DC18V	1	
44	0601831585	PREHEAT BUTTON	1	
45	0601831586	CAP	1	
46	M1224100104	STOPPER	1	
47	0027105010	MACHINE SCREW	2	
48	0027105010	MACHINE SCREW	4	
49	M9220100004	SET SCREW	2	
50	0080200007	SNAP RING	2	
51	1825530401	STARTER RELAY	1	REPLACES P/N 0602200304
52	0016906016	MACHINE SCREW	2	
53	LY2DDC12V	RELAY	1	
53A	PTF08AE	BASE	1	
53B	PYCA1	CAP	2	
54	0027104020	MACHINE SCREW	2	
55	0601823240	RECTIFIER, DE45	1	
56	0027104020	MACHINE SCREW	1	
57	0601827680	STARTER RELAY	1	
58	0027104020	MACHINE SCREW	2	
59	0602202546	CONTROLLER (EGS)DYN1	1	
60	0027105016	MACHINE SCREW	4	
60A	0207005000	HEX NUT	4	
61	0602122272	UNIT, OIL PRESSURE	1	
62	M9200100004	ADAPTER	1	
63	8971256000	SENDER, WATER SWITCH	1	
64	9095720140	PACKING	1	REPLACES P/N 0602121109
65	0602120480	PICK UP, TACHOMETER	1	
66	M2246701504	WIRE HARNESS, GENERATOR	1	
67	M2357201102	WIRE HARNESS, ENGINE	1	
68	M3357200304	WIRE HARNESS, FUEL LEAK	1	
69	0601802149	FUSE, 10A	3	

DCA-70USI (60 Hz) — ENGINE AND RADIATOR ASSY.

ENGINE AND RADIATOR ASSY.

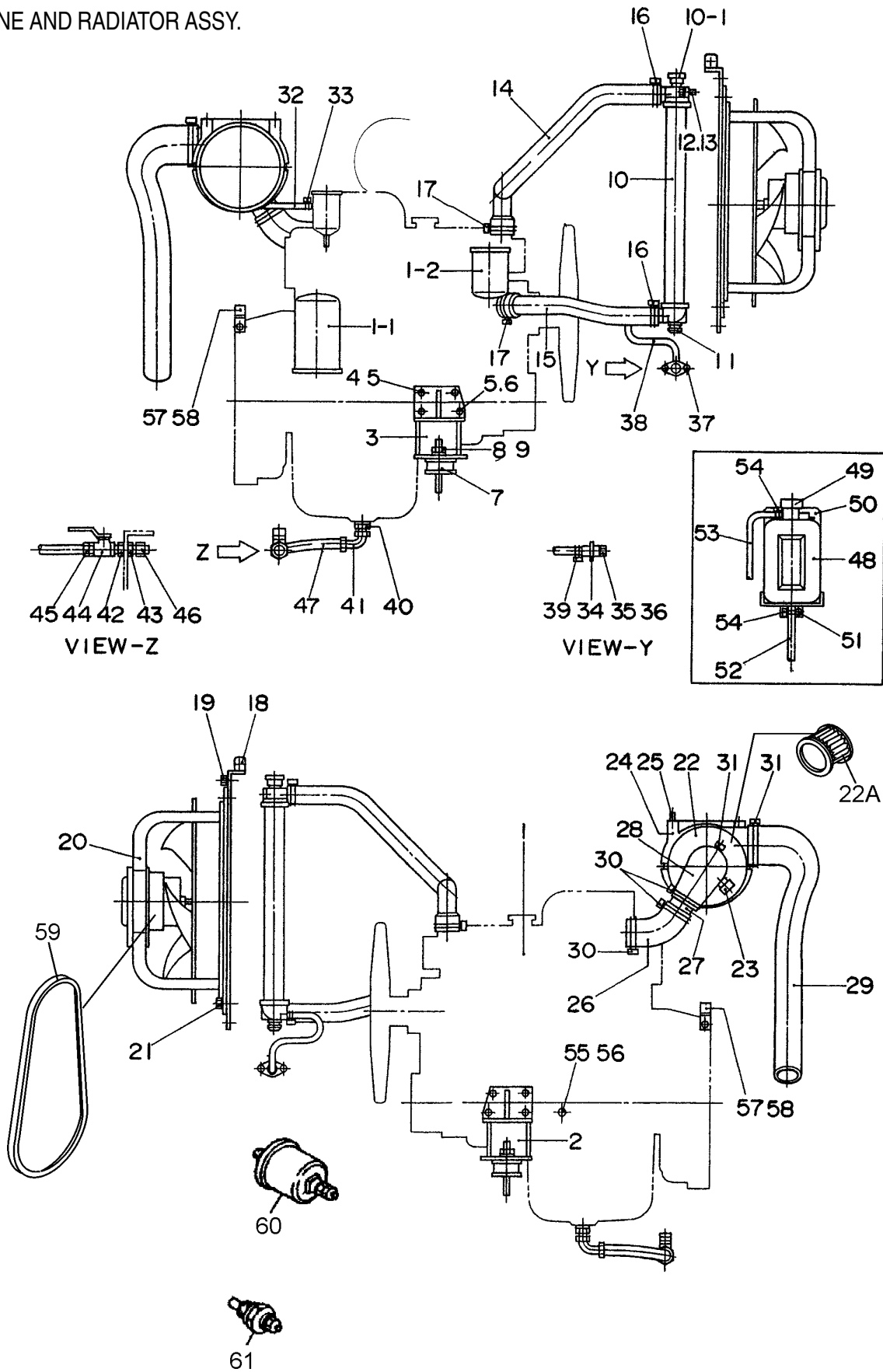

DCA-70USI (60 Hz) — ENGINE AND RADIATOR ASSY.

ENGINE AND RADIATOR ASSY.

<u>NO.</u>	<u>PART NO.</u>	<u>PART NAME</u>	<u>QTY.</u>	<u>REMARKS</u>
1	M2923200024	ENGINE, ISUZU FF-4BG1T	1	
1-1	1132402311	CARTRIDGE, OIL FILTER	1	REPLACES P/N 0602041216
1-2	1132400791	CARTRIDGE, FUEL FILTER	1	REPLACES P/N 0602042407
2	M1303200103	ENGINE FOOT	1	
3	M1303200203	ENGINE FOOT	1	
4	0010710025	HEX HEAD BOLT	7	
5	0042510000	SPRING WASHER	8	
6	0030410000	HEX, NUT	1	
7	0605000009	RUBBER SUSPENSION	2	
8	0030012000	HEX, NUT	2	
9	0040012000	SPRING WASHER	2	
10	M2923200044	RADIATOR	1	
10-1	0602011053	CAP, RADIATOR	1	
11	M9312200104	MOUNT RUBBER	2	
12	0016908040	HEX, HEAD BOLT	2	
13	0207008000	HEX, NUT	2	
14	M2310500803	RADIATOR HOSE	1	
15	M2310500903	RADIATOR HOSE	1	
16	0605515147	HOSE BAND	2	
17	0605515199	HOSE BAND	2	
18	M2313300404	FAN BRACKET	1	
19	0017110030	HEX, HEAD BOLT	4	
20	0601822798	FAN MOTOR	1	
21	0017110030	HEX, HEAD BOLT	4	
22	0602046582	AIR CLEANER	1	
22A	0602046365	ELEMENT, AIR CLEANER	1	
23	0602040651	INDICATOR, AIR CLEANER	1	
24	0602040554	BAND, AIR CLEANER	1	
25	0016908030	HEX, HEAD BOLT	2	
26	M2373100404	HOSE, AIR CLEANER	1	
27	M2326100004	BLOWBY PIPE	1	
28	M2373100304	HOSE, AIR CLEANER	1	
29	M1374100103	HOSE, AIR CLEANER	1	
30	0605515146	HOSE BAND	3	
31	0605515197	HOSE BAND	2	
32	0191300450	BLOWBY HOSE	1	
33	0605515198	HOSE BAND	2	
34	M2320300103	DRAIN JOINT	1	
35	M9200200004	PLUG	1	

DCA-70USI (60 Hz) — ENGINE AND RADIATOR ASSY. (CONT.)

ENGINE AND RADIATOR ASSY.

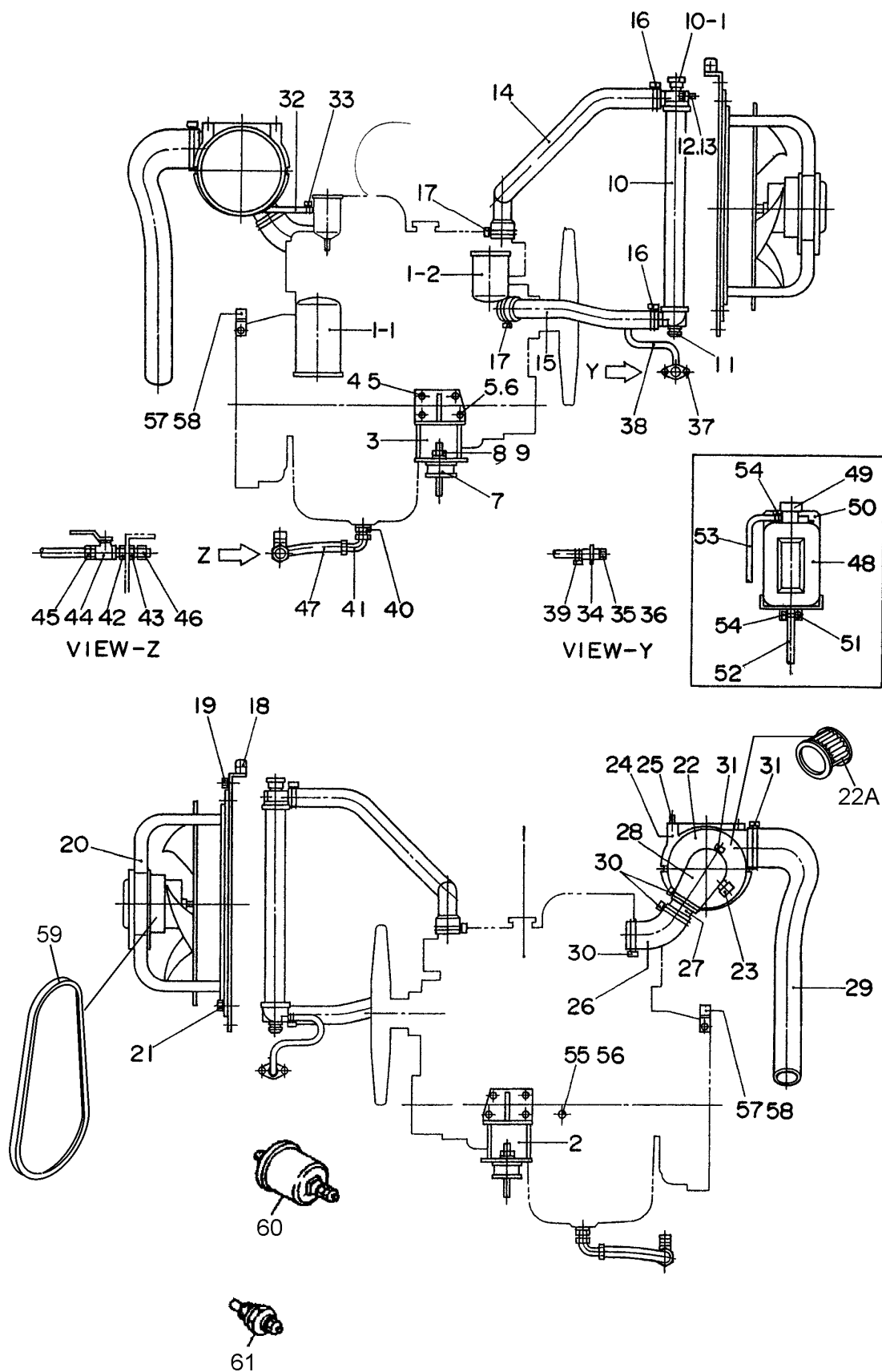

DCA-70USI (60 Hz) — ENGINE AND RADIATOR ASSY. (CONT.)

ENGINE AND RADIATOR ASSY.

<u>NO.</u>	<u>PART NO.</u>	<u>PART NAME</u>	<u>QTY.</u>	<u>REMARKS</u>
36	0150000018	O RING	1	
37	0016906020	HEX, HEAD BOLT	2	
38	0199900600	DRAIN HOSE	1	
39	0605515106	HOSE BAND	1	
40	0602022560	ADAPTER	1	
41	0602022561	90 DEG. ELBOW	1	
42	0602206590	CONNECTOR	1	
43	0603300285	ROCKNUT	1	
44	0605511395	VALVE	1	
45	0603306395	HOSE JOINT	1	
46	0602021070	CAP	1	
47	0269200420	DRAIN HOSE	1	
48	M9300000203	RESERVE TANK	1	
49	0602010900	CAP, RESERVE TANK	1	
50	M3316100303	BRACKET, RESERVE TANK	1	
51	0016908020	HEX, HEAD BOLT	3	
52	0199102000	HOSE	1	
53	0193600700	HOSE	1	
54	0605515106	HOSE BAND	3	
55	0017112025	HEX, HEAD BOLT	1	
56	0040512000	TOOTHED WASHER	1	
57	0602220911	CLAMP	2	
58	0017110020	HEX, HEAD BOLT	2	
59	8972333820	FAN BELT	1 REPLACES P/N 0602011434
60	0602123260	UNIT, WATER TEMPERATURE	1	
61	9827200690	SENDER, OIL SWITCH	1	

DCA-70USI (60 Hz) — OUTPUT TERMINAL ASSY.

OUTPUT TERMINAL ASSY.

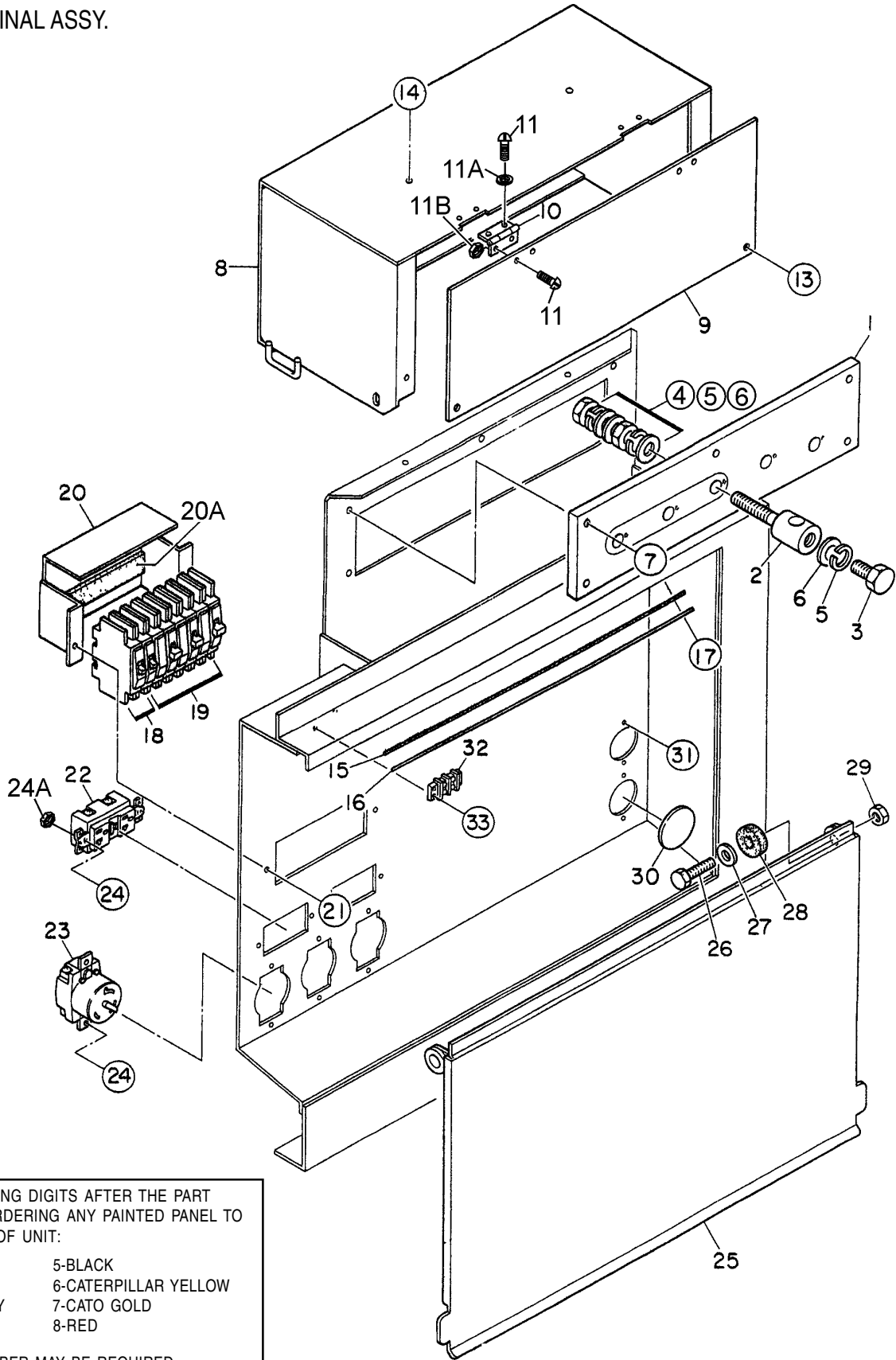

ADD THE FOLLOWING DIGITS AFTER THE PART NUMBER WHEN ORDERING ANY PAINTED PANEL TO INDICATE COLOR OF UNIT:

- | | |
|-----------------|----------------------|
| 1-ORANGE | 5-BLACK |
| 2-WHITE | 6-CATERPILLAR YELLOW |
| 3-SPECTRUM GREY | 7-CATO GOLD |
| 4-SUNBELT GREEN | 8-RED |

THE SERIAL NUMBER MAY BE REQUIRED.

DCA-70USI (60 Hz) — OUTPUT TERMINAL ASSY.

OUTPUT TERMINAL ASSY.

<u>NO.</u>	<u>PART NO.</u>	<u>PART NAME</u>	<u>QTY.</u>	<u>REMARKS</u>
1	M2230700113	TERMINAL PANEL	1	
2	M2233000004	OUTPUT TERMINAL BOLT	5	
3	M2233100004	TIE BOLT	5	
4	0039312000	HEX, NUT	10	
5	0040012000	SPRING WASHER	15	
6	0041412000	PLAIN WASHER	20	
7	0016908035	HEX, HEAD BOLT	5	
8	M3236100503	TERMINAL COVER	1	
9	M3236100404	OUTPUT WINDOW	1	
10	0605010040	HINGE	2	
11	0027103010	MACHINE SCREW	4	
11A	0030003000	HEX, NUT	4	
11B	0041203000	PLAIN WASHER	4	
12	0027103010	MACHINE SCREW	4	
12A	0030003000	HEX, NUT	4	
13	0016906020	HEX, HEAD BOLT	2	
14	0016906016	HEX, HEAD BOLT	4	
15	M3236400004	CABLE OUTLET COVER	1	
16	M3236300004	SUPPORTER, CABLE OUTLET COVER	1	
17	0016906020	HEX, HEAD BOLT	6	
18	0601870440	CIRCUIT BREAKER, 1-POLE, 20A	2	
19	0601870441	CIRCUIT BREAKER, 2-POLE 50A	3	
20	M1260700504	BREAKER FITTING COVER	1	
20A	0222100100	CUSHION RUBBER	2	
21	0016906020	HEX, HEAD BOLT	2	
22	0601812598	RECEPTACLE, 125V 20A	2	
23	0601812538	RECEPTACLE, CS6369 250V 50A	3	
24	0027104016	MACHINE SCREW	10	
24A	0207004000	HEX, NUT	10	
25	M2236100603	TERMINAL COVER	1	
26	0010112045	HEX, HEAD BOLT	2	
27	0041212000	PLAIN WASHER	2	
28	M9310200004	STAY RUBBER	2	
29	0030012000	HEX, NUT	2	
30	0603306775	BLIND PLUG	2	
31	0027104016	MACHINE SCREW	4	
32	0601815194	TERMINAL	1	
33	0027104016	MACHINE SCREW	2	

DCA-70USI (60 Hz) — BATTERY ASSY.

BATTERY ASSY.

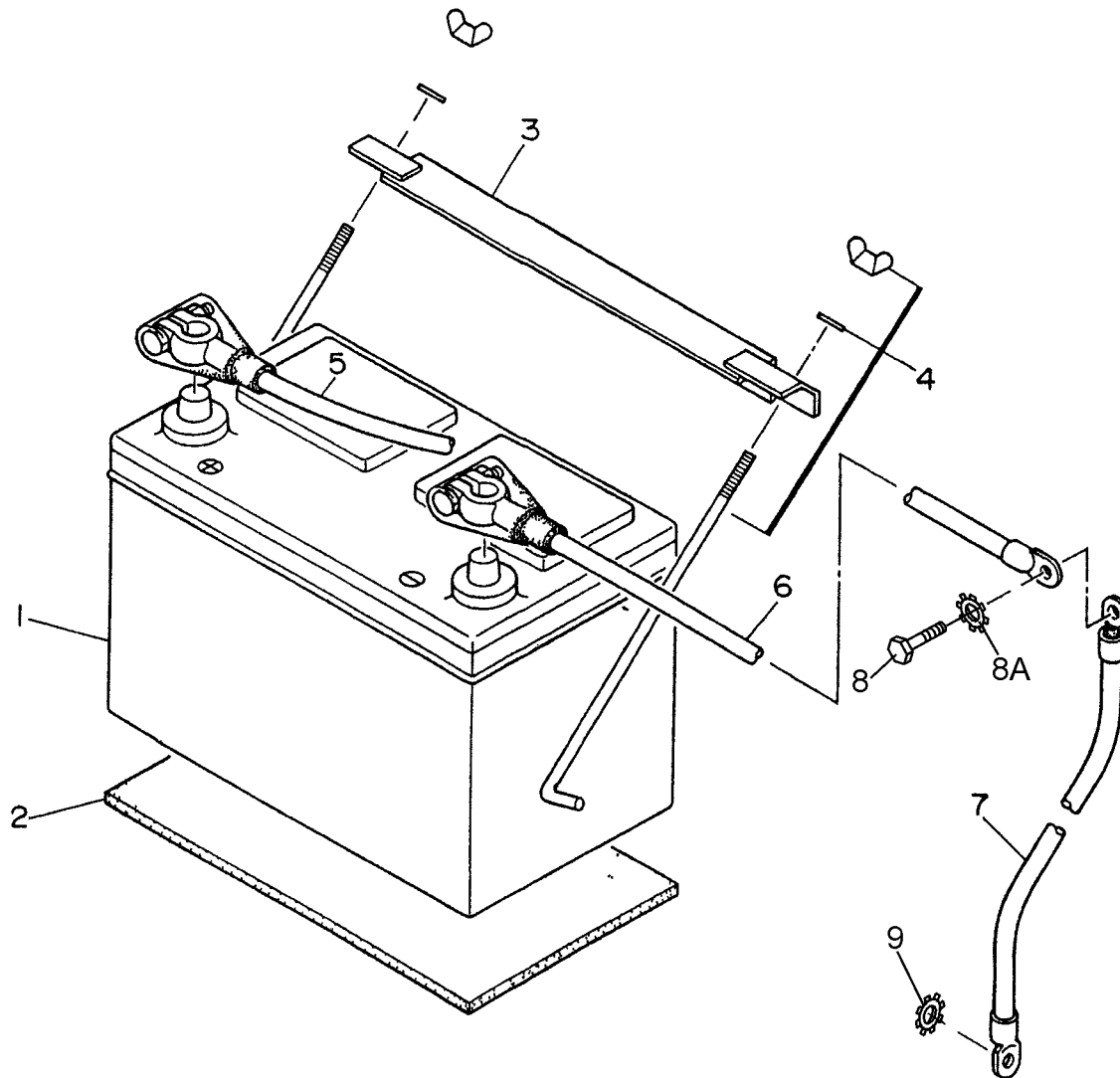

DCA-70USI (60 Hz) — BATTERY ASSY.

BATTERY ASSY.

<u>NO.</u>	<u>PART NO.</u>	<u>PART NAME</u>	<u>QTY.</u>	<u>REMARKS</u>
1	0602220187	BATTERY, 627MFD	1	
2	M9210500014	BATTERY SHEET	1	
3	M9103000304	BATTERY BAND	1	
4	0602220920	BATTERY BOLT SET	2	
5	M2346900404	BATTERY CABLE	1	
6	M2346900104	BATTERY CABLE	1	
7		CABLE	1 MAKE LOCALLY
8	0017112025	HEX, HEAD BOLT	1	
8A	0040512000	TOOTHED WASHER	1	
9	0040520000	TOOTHED WASHER	1	

DCA-70USI (60 Hz) — MUFFLER ASSY.

MUFFLER ASSY.

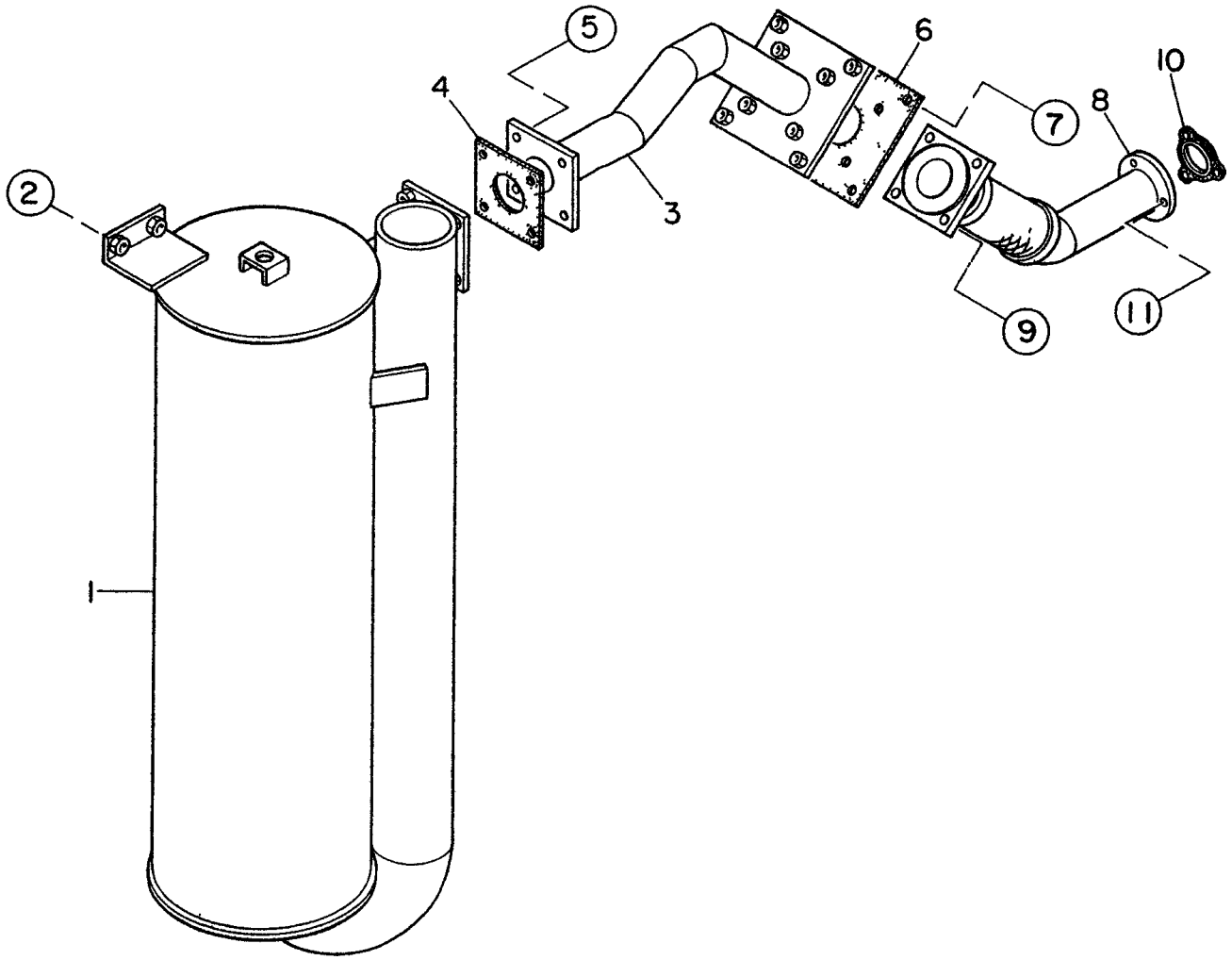

DCA-70USI (60 Hz) — MUFFLER ASSY.

MUFFLER ASSY.

<u>NO.</u>	<u>PART NO.</u>	<u>PART NAME</u>	<u>QTY.</u>	<u>REMARKS</u>
1	M2330101003	MUFFLER	1	
2	0017112030	HEX, HEAD BOLT	4	
3	M233000903	EXHAUST PIPE	1	
4	M2333200404	GASKET	1	
5	0017110040	HEX, HEAD BOLT	4	
6	M2333200304	GASKET	1	
7	0017110035	HEX, HEAD BOLT	4	
8	M2333000803	EXHAUST PIPE	1	
9	0017110050	HEX, HEAD BOLT	4	
10	3943690210	GASKET	1	REPLACES P/N 0602320101
11	0039308000	HEX, NUT	6	

DCA-70USI (60 Hz) — FUEL TANK ASSY.

FUEL TANK ASSY.

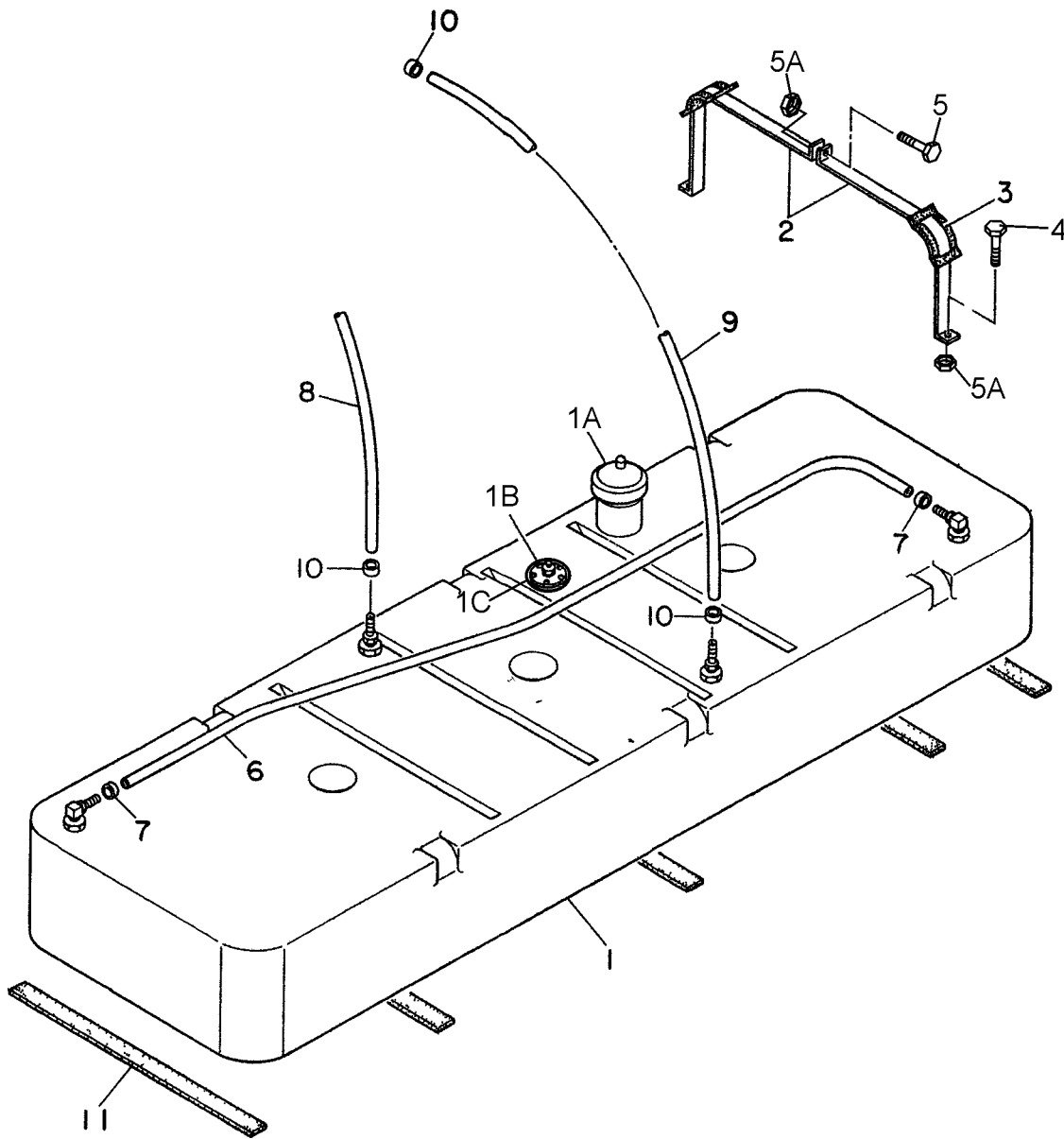

DCA-70USI (60 Hz) — FUEL TANK ASSY.

FUEL TANK ASSY.

<u>NO.</u>	<u>PART NO.</u>	<u>PART NAME</u>	<u>QTY.</u>	<u>REMARKS</u>
1	M2363001202	FUEL TANK	1	
1A	0605505070	FUEL TANK CAP	1	
1B	0605501079	FUEL SENDER UNIT	1	
1C	0605516090	GASKET	1	
2	M2363200704	TANK BAND	6	
3	M9310500104	SUPPORTER SHEET	6	
4	0016908020	HEX, HEAD BOLT	6	
5	0016908055	HEX, HEAD BOLT	3	
5A	0207008000	HEX, NUT	9	
6	0191302200	VENT HOSE	1	
7	0605515109	HOSE BAND	2	
8	0191300900	SUCTION HOSE	1	
9	0191301100	RETURN HOSE	1	
10	0605515109	HOSE BAND	4	
11	0222100710	TANK SHEET	5	

DCA-70USI (60 Hz) — ENCLOSURE #1 ASSY.

ENCLOSURE #1 ASSY.

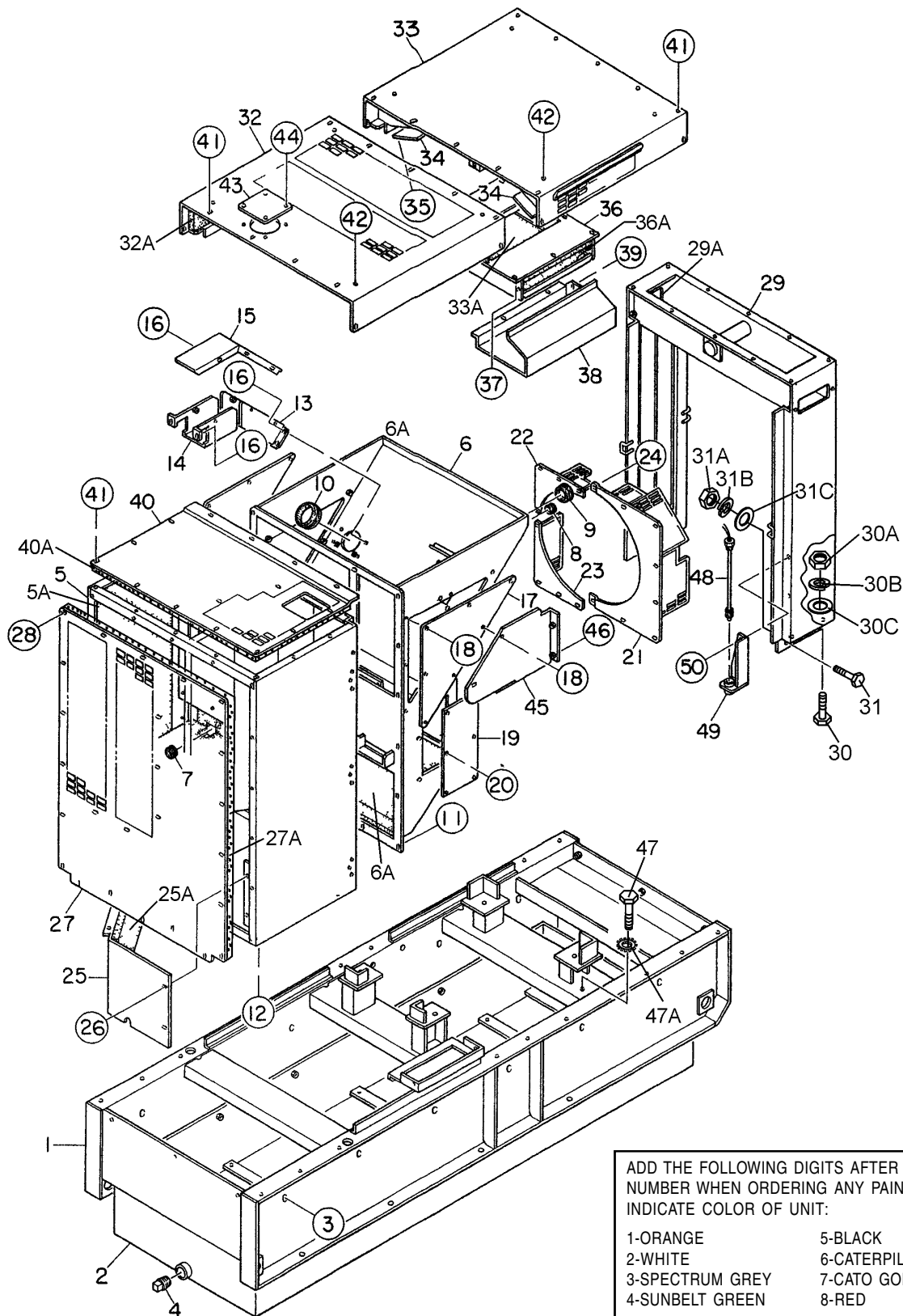

ADD THE FOLLOWING DIGITS AFTER THE PART NUMBER WHEN ORDERING ANY PAINTED PANEL TO INDICATE COLOR OF UNIT:

- | | |
|-----------------|----------------------|
| 1-ORANGE | 5-BLACK |
| 2-WHITE | 6-CATERPILLAR YELLOW |
| 3-SPECTRUM GREY | 7-CATO GOLD |
| 4-SUNBELT GREEN | 8-RED |

THE SERIAL NUMBER MAY BE REQUIRED.

DCA-70USI (60 Hz) — ENCLOSURE #1 ASSY.

ENCLOSURE #1 ASSY.

<u>NO.</u>	<u>PART NO.</u>	<u>PART NAME</u>	<u>QTY.</u>	<u>REMARKS</u>
1	M2413001702	BASE	1	
2	M2363300603	ENVIRONMENTAL TANK	1	
3	0016910030	HEX, HEAD BOLT	12	
4	0603306797	PLUG	1	
5	M2423001302	FRONT FRAME	1	
5A	M2493104603	ACOUSTIC SHEET	1	
6	M2423001402	FRONT FRAME	1	
6A	M2493104603	ACOUSTIC SHEET	1	
7	0601850265	GROMMET	1	
8	0601850263	GROMMET	1	
9	0601851736	GROMMET	1	
10	0601851739	GROMMET	1	
11	0016908020	HEX, HEAD BOLT	20	
12	0016910025	HEX, HEAD BOLT	6	
13	M2310600204	HOSE COVER	1	
14	M2310600304	HOSE COVER	1	
15	M2310600004	HOSE COVER	1	
16	0016906020	HEX, HEAD BOLT	12	
17	M3423200704	DUCT COVER	2	
18	0016906020	HEX, HEAD BOLT	14	
19	M3423200804	DUCT COVER	1	
20	0016906016	HEX, HEAD BOLT	6	
21	M2310300704	FAN SHROUD	1	
22	M2310300804	FAN SHROUD	1	
23	M2310300904	FAN SHROUD	1	
24	0016906020	HEX, HEAD BOLT	14	
25	M2423300204	DISCHARGE GUIDE	1	
25A	M2493104504	ACOUSTIC SHEET	1	
26	0016908020	HEX, HEAD BOLT	6	
27	M243202004	COVER, FRONT FRAME	1	
27A	M2493104304	ACOUSTIC SHEET	1	
28	0019208020	HEX, HEAD BOLT	25	
29	M2433000803	CENTER FRAME	1	
29A	M2493200004	ACOUSTIC SHEET	1	
30	0010114040	HEX, HEAD BOLT	4	
30A	0030014000	HEX, NUT	4	
30B	0040014000	SPRING WASHER	4	
30C	0041214000	PLAIN WASHER	8	

DCA-70USI (60 Hz) — ENCLOSURE #1 ASSY. (CONT.)

ENCLOSURE #1 ASSY.

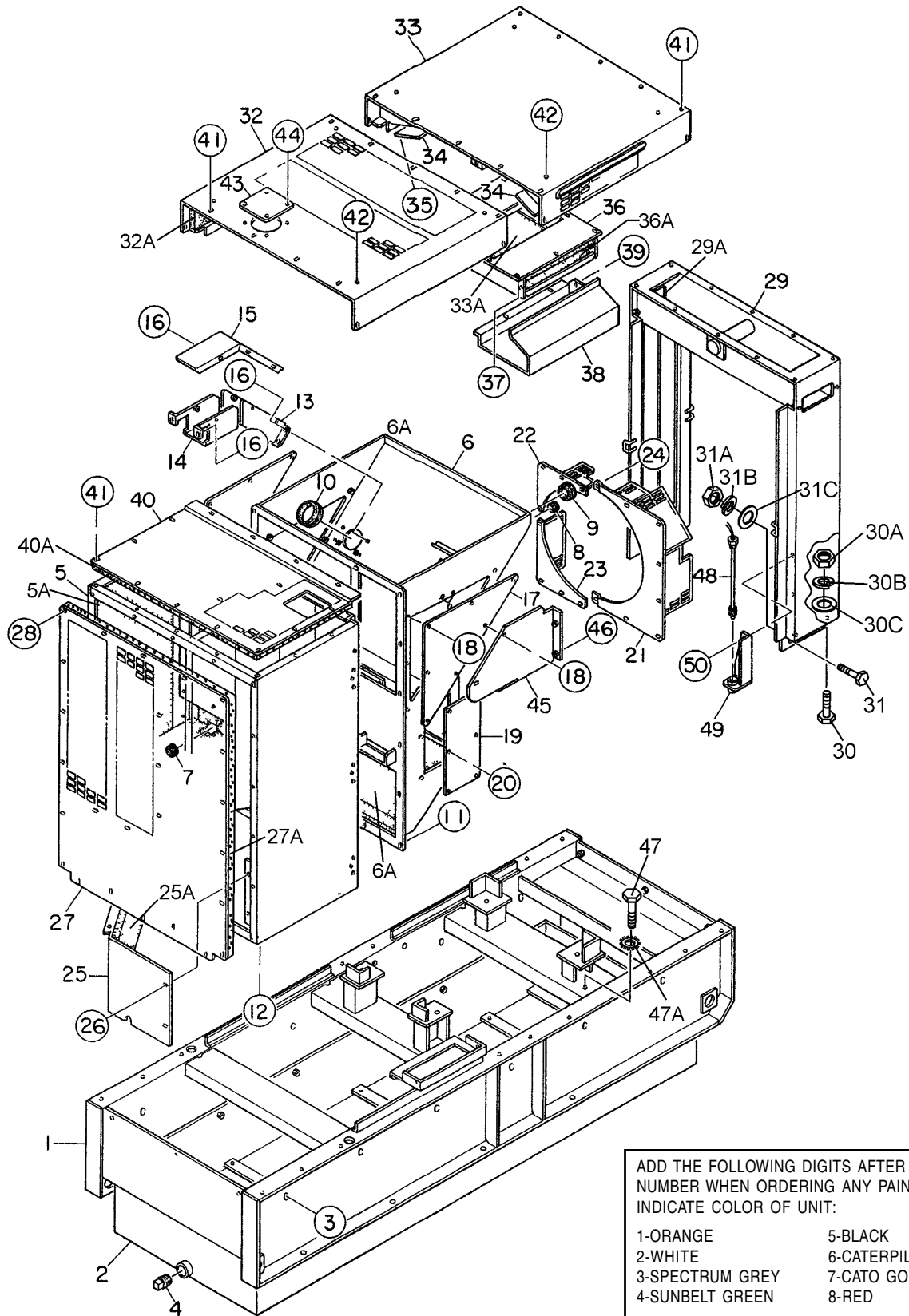

ADD THE FOLLOWING DIGITS AFTER THE PART NUMBER WHEN ORDERING ANY PAINTED PANEL TO INDICATE COLOR OF UNIT:

- | | |
|-----------------|----------------------|
| 1-ORANGE | 5-BLACK |
| 2-WHITE | 6-CATERPILLAR YELLOW |
| 3-SPECTRUM GREY | 7-CATO GOLD |
| 4-SUNBELT GREEN | 8-RED |

THE SERIAL NUMBER MAY BE REQUIRED.

DCA-70USI (60 Hz) — ENCLOSURE #1 ASSY. (CONT.)

ENCLOSURE (PART 1) ASSY.

<u>NO.</u>	<u>PART NO.</u>	<u>PART NAME</u>	<u>QTY.</u>	<u>REMARKS</u>
31	0010120050	HEX, HEAD BOLT	4	
31A	0030020000	HEX, NUT	4	
31B	0040020000	SPRING WASHER	4	
31C	0041220000	PLAIN WASHER	8	
32	M2463100302	ROOF PANEL	1	
32A	M2493502604	ACOUSTIC SHEET	1	
33	M2463200302	ROOF PANEL	1	
33A	M2493502403	ACOUSTIC SHEET	1	
34	M3463200704	BACK PLATE	2	
35	0016906016	HEX, HEAD BOLT	12	
36	M2463200503	DUCT	1	
36A	M2493502704	ACOUSTIC SHEET	1	
37	0016908020	HEX, HEAD BOLT	10	
38	M2463400103	DUCT COVER	1	
39	0016908020	HEX, HEAD BOLT	6	
40	M2423201504	OVER COVER, FRONT FRAME	1	
40A	M2493104404	ACOUSTIC SHEET	1	
41	0019208020	HEX, HEAD BOLT	42	
42	0019210025	HEX, HEAD BOLT	8	
43	M3310600004	COVER, RADIATOR CAP	1	
44	0019208020	HEX, HEAD BOLT	4	
45	M2483100304	COVER, EXHAUST PIPE	1	
46	0016908020	HEX, HEAD BOLT	2	
47	0016908020	HEX, HEAD BOLT	1	
47A	0040508000	TOOTHED WASHER	1	
48	0605503062	FUEL LEAK DETECTED SWITCH	1	
49	M1414800104	BRACKET	1	
50	0017108020	HEX, HEAD BOLT	2	

DCA-70USI (60 Hz) — ENCLOSURE #2 ASSY.

ENCLOSURE #2 ASSY.

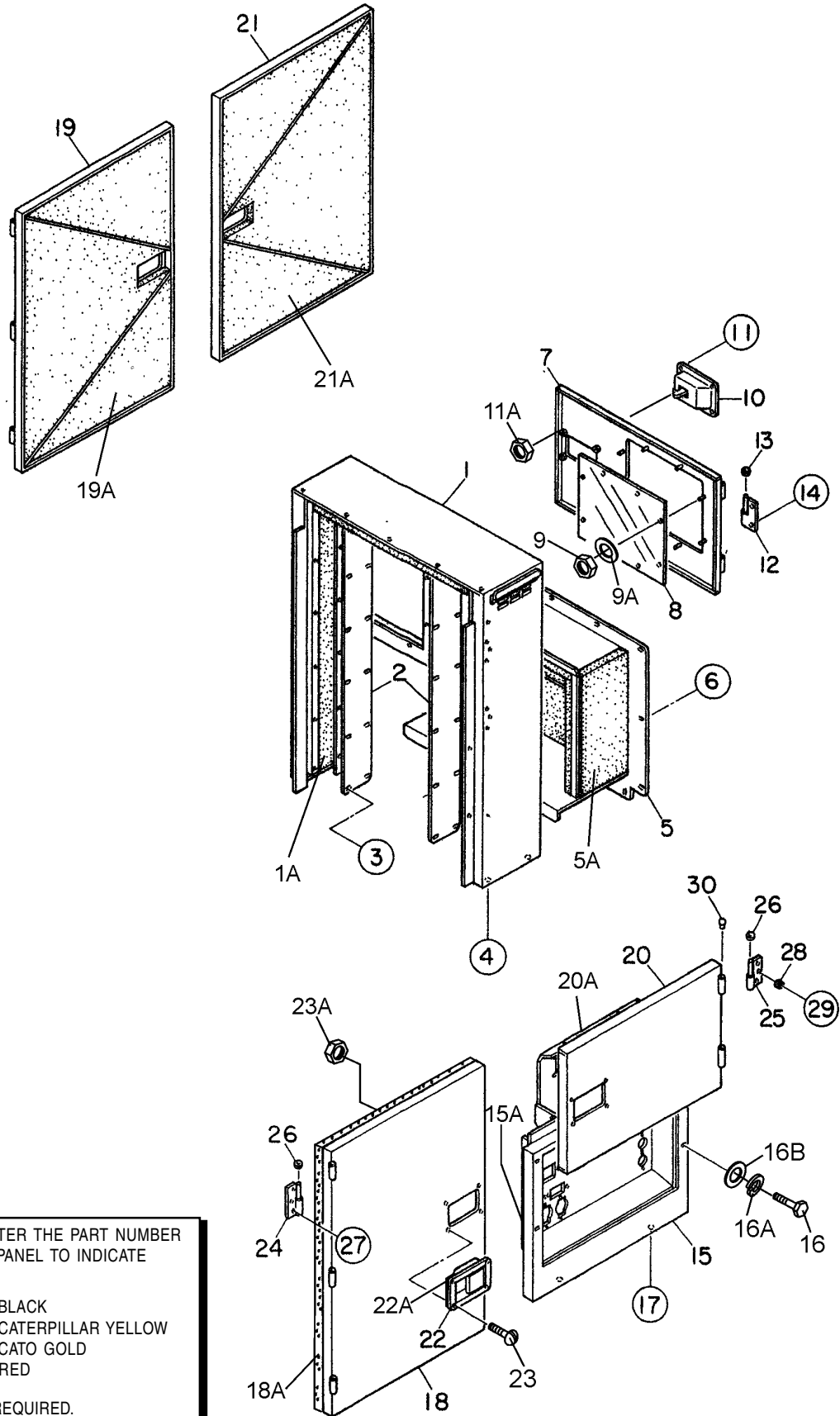

ADD THE FOLLOWING DIGITS AFTER THE PART NUMBER WHEN ORDERING ANY PAINTED PANEL TO INDICATE COLOR OF UNIT:

- | | |
|-----------------|----------------------|
| 1-ORANGE | 5-BLACK |
| 2-WHITE | 6-CATERPILLAR YELLOW |
| 3-SPECTRUM GREY | 7-CATO GOLD |
| 4-SUNBELT GREEN | 8-RED |

THE SERIAL NUMBER MAY BE REQUIRED.

DCA-70USI (60 Hz) — ENCLOSURE #2 ASSY.

ENCLOSURE #2 ASSY.

<u>NO.</u>	<u>PART NO.</u>	<u>PART NAME</u>	<u>QTY.</u>	<u>REMARKS</u>
1	M2443000802	REAR FRAME	1	
1A	M2493303103	ACOUSTIC SHEET	1	
2	M2443000604	DUCT	2	
3	0016908020	HEX, HEAD BOLT	24	
4	0016910025	HEX, HEAD BOLT	4	
5	M2443301103	COVER, REAR FRAME	1	
5A	M2493303004	ACOUSTIC SHEET	1	
6	0019208020	HEX, HEAD BOLT	12	
7	M2443200303	DOOR, REAR FRAME	1	
8	M1444600004	WINDOW PLATE	1	
9	0207006000	HEX, NUT	8	
9A	0041206000	PLAIN WASHER	8	
10	M9113000002	DOOR HANDLE ASSY	1	
11	0021806016	MACHINE SCREW	4	
11A	0030006000	HEX, NUT	4	
12	M9110100204	HINGE	2	
13	M9116100004	WASHER	2	
14	0019208020	HEX, HEAD BOLT	3	
15	M2453201202	SPLASHER PANEL	1	
15A	M2493405204	ACOUSTIC SHEET	1	
16	0019108065	HEX, HEAD BOLT	4	
16A	0042308000	SPRING WASHER	4	
16B	0042408000	PLAIN WASHER	4	
17	0016910025	HEX, HEAD BOLT	2	
18	M2453001703	SIDE DOOR	1	
18A	M2493404704	ACOUSTIC SHEET	1	
19	M2453001803	SIDE DOOR	1	
19A	M2493405104	ACOUSTIC SHEET	1	
20	M2453001903	SIDE DOOR	1	
20A	M2493405304	ACOUSTIC SHEET	1	
21	M2453001703	SIDE DOOR	1	
21A	M2493404704	ACOUSTIC SHEET	1	
22	M9113000002	DOOR HANDLE ASSY	4	
22A	C9312500004	SEAL RUBBER	4	
23	0021806016	MACHINE SCREW	16	
23A	0030006000	HEX, NUT	16	
24	M9110100804	HINGE	6	
25	M9110100904	HINGE	5	
26	M9116100004	WASHER	11	
27	0019208020	HEX, HEAD BOLT	26	
28	0601850097	STOPPER	8	
29	0027208025	MACHINE SCREW	8	
30	M9310000004	CAP	13	

DCA-70USI (60 Hz) — RUBBER SEALS ASSY.

RUBBER SEALS ASSY.

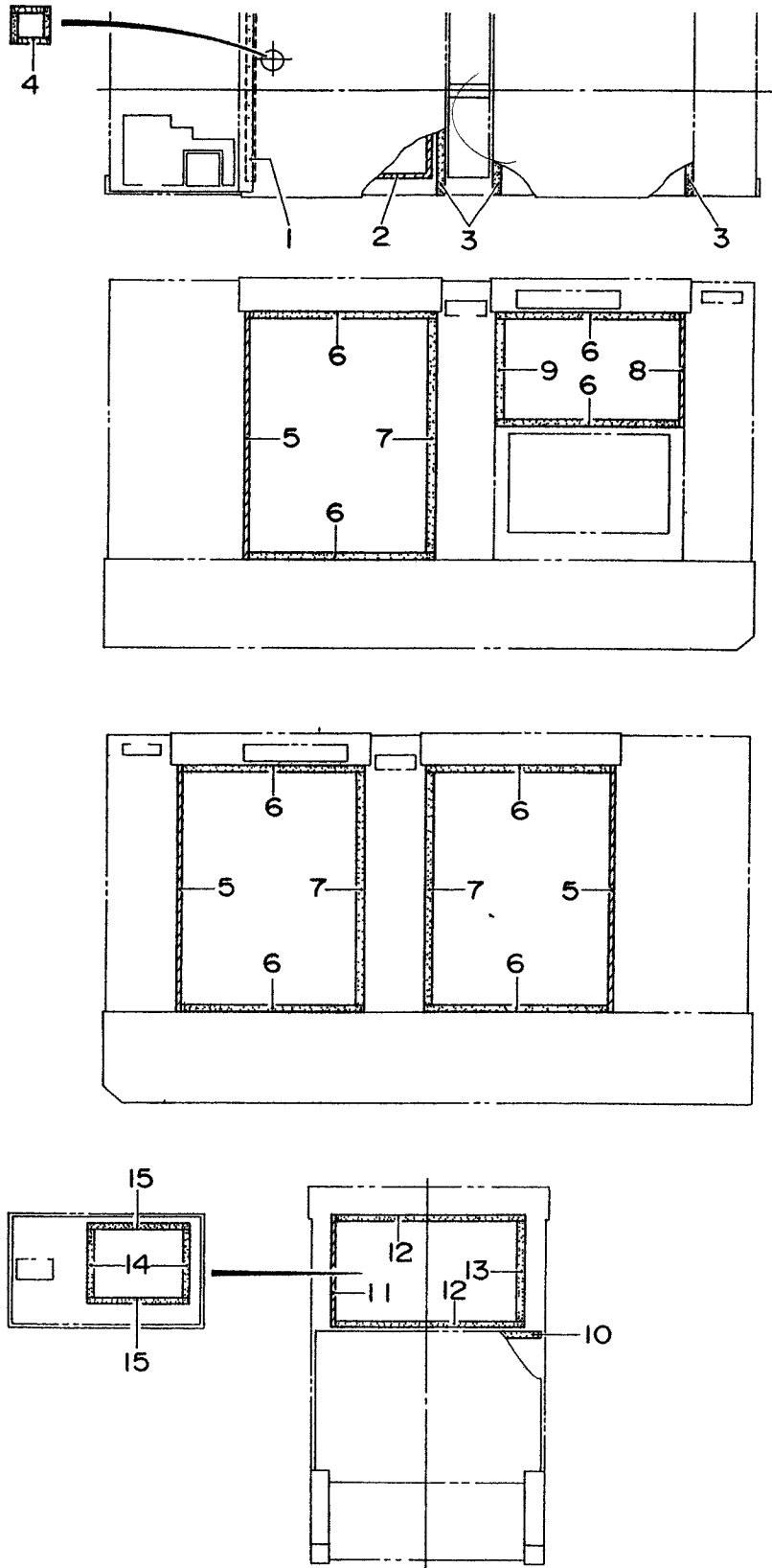

DCA-70USI (60 Hz) — RUBBER SEALS ASSY.

RUBBER SEALS ASSY.

<u>NO.</u>	<u>PART NO.</u>	<u>PART NAME</u>	<u>QTY.</u>	<u>REMARKS</u>
1	0229200840	RUBBER SEAL	1	
2	0314502250	RUBBER SEAL	1	
3	0229200950	RUBBER SEAL	3	
4	0229200125	RUBBER SEAL	4	
5	0228901165	RUBBER SEAL	3	
6	0228900770	RUBBER SEAL	8	
7	0228901105	RUBBER SEAL	3	
8	0228900535	RUBBER SEAL	1	
9	0228900475	RUBBER SEAL	1	
10	0229200910	RUBBER SEAL	1	
11	0228800525	RUBBER SEAL	1	
12	0228800790	RUBBER SEAL	2	
13	0228800475	RUBBER SEAL	1	
14	0228100325	RUBBER SEAL	2	
15	0228100420	RUBBER SEAL	2	

DCA-70USI (60 Hz) — NAME PLATE AND DECALS ASSY.

NAMEPLATE AND DECALS ASSY.

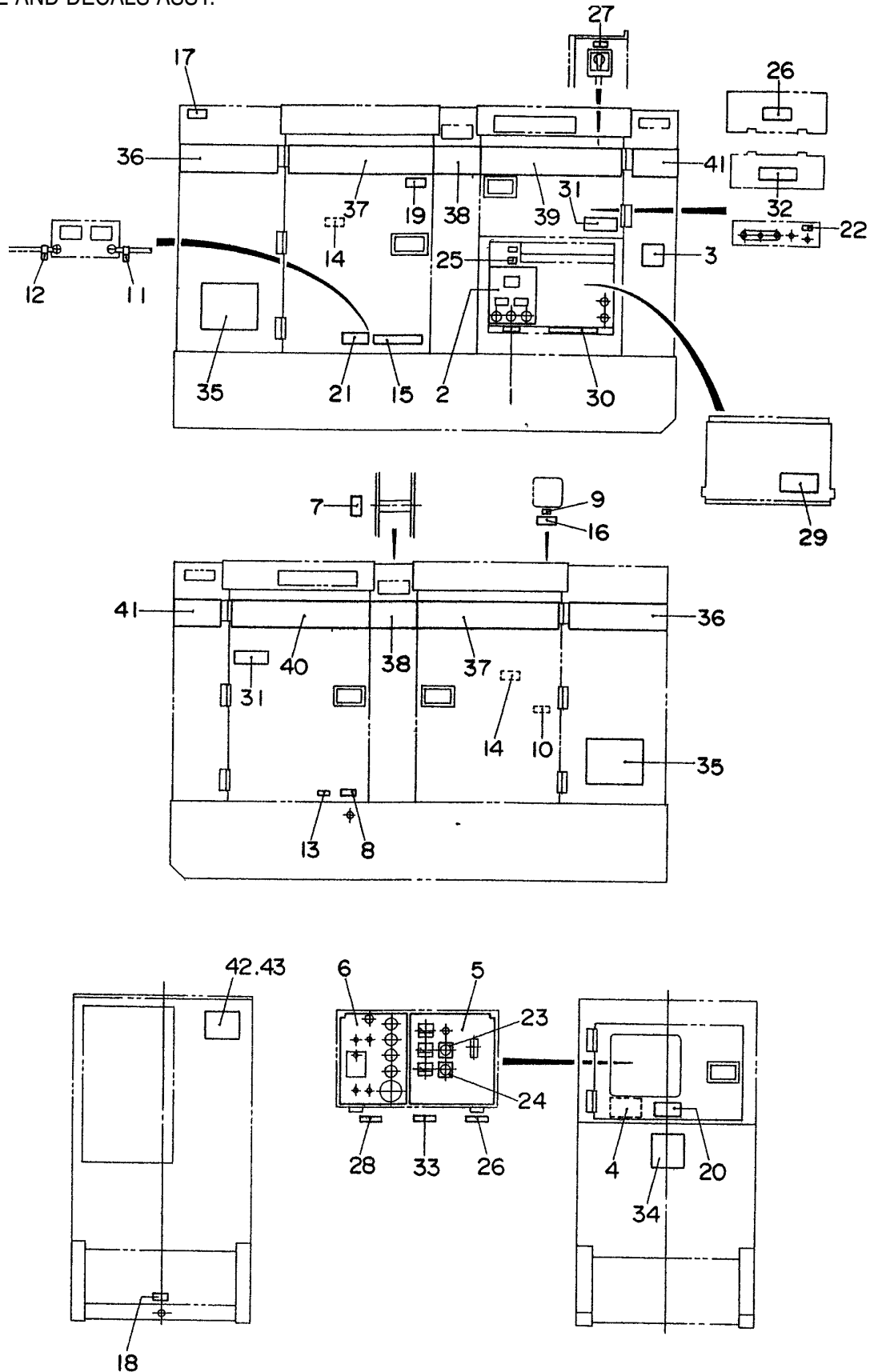

DCA-70USI (60 Hz) — NAME PLATE AND DECALS ASSY.

NAMEPLATE AND DECALS ASSY.

<u>NO.</u>	<u>PART NO.</u>	<u>PART NAME</u>	<u>QTY.</u>	<u>REMARKS</u>
1	M1550000204	DECAL; NOTE	1	M15000020
2	M1550002203	DECAL; AUXILIARY OUTPUT	1	M15000220
3	M2550000304	DECAL; NOTE	1	M25000030
4	M2550000703	DECAL; OPERATING PROCEDURES	1	M25000070
5	M2550000803	DECAL; GENERATOR CONTROL	1	M25000080
6	M2550000903	DECAL; ENGINE OPERATING	1	M25000090
7	M3550002204	DECAL; CAUTION	1	M35000220
8	M9500000004	DECAL; OIL DRAIN PLUG	1	M90000000
9	M9500100004	DECAL; WATER	1	M90010000
10	M9500100104	DECAL; WATER DRAIN	1	M90010010
11	M9500300004	DECAL; -	1	M90030000
12	M9500300104	DECAL; +	1	M90030010
13	M9500500004	DECAL; DIESEL FUEL	1	M90050000
14	M9503000004	DECAL; WARNING MOVING PARTS	2	M90300000
15	M9503000103	DECAL; WATER-OIL CHECK	1	M90300010
16	M9503100004	DECAL; WARNING HOT COOLANT	1	M90310000
17	M9503200004	DECAL; WARNING ENGINE EXHAUST	1	M90320000
18	M9510000004	DECAL; FULID DRAIN	1	M91000000
19	M9510100004	DECAL; CAUTION HOT PARTS	1	M91010000
20	M9510100304	DECAL; ENVIRONMENTAL WARNING	1	M91010030
21	M9510100403	DECAL; CAUTION	1	M91010040
22	M9520000004	DECAL; GROUND	1	M92000000
23	M9520000104	DECAL; AMMETER CHANGE-OVER SW.	1	M92000010
24	M9520000204	DECAL; VOLTMETER CHANGE-OVER SW. ...	1	M92000020
25	M9520000504	DECAL; START CONTACT	1	M92000050
26	M9520100004	DECAL; WARNING ELECT. SHOCK HAZ.	1	M92010000
27	M9520100204	DECAL; CAUTION	1	M92010020A
28	M9520100304	DECAL; SAFETY INSTRUCTIONS	1	M92010030
29	M9520100404	DECAL; DANGER HIGH VOLTAGE	1	M92010040
30	M9520100503	DECAL; WARNING	1	M92010050
31	M9520100603	DECAL; CAUTION	2	M92010060
32	M9520200003	DECAL; CONNECTION OF OUTPUT CABLE .	1	M92020000
33	M9520200404	DECAL; OVER CURRENT RELAY	1	M92020040
34	M9512200004	DECAL; MQ	1	M91220000
35	M9510200304	DECAL; MQ POWER	2	
36	M2560101104	STRIPE	2	
37	M2560100603	STRIPE; WHISPERWATT	2	
38	M3560102204	STRIPE	2	
39	M2560101303	STRIPE; 70	1	
40	M2561002504	STRIPE; 70	1	
41	M3560102504	STRIPE	2	
42	0600500092	PLATE; MQ POWER	1	
43	0021106016	MACHINE SCREW	4	

PAYMENT TERMS

Terms of payment for parts are net 10 days.

FREIGHT POLICY

All parts orders will be shipped collect or prepaid with the charges added to the invoice. All shipments are F.O.B. point of origin. Multiquip's responsibility ceases when a signed manifest has been obtained from the carrier, and any claim for shortage or damage must be settled between the consignee and the carrier.

MINIMUM ORDER

The minimum charge for orders from Multiquip is \$15.00 net. Customers will be asked for instructions regarding handling of orders not meeting this requirement.

RETURNED GOODS POLICY

Return shipments will be accepted and credit will be allowed, subject to the following provisions:

1. A Returned Material Authorization must be approved by Multiquip prior to shipment.
2. To obtain a Return Material Authorization, a list must be provided to Multiquip Parts Sales that defines item numbers, quantities, and descriptions of the items to be returned.
 - a. The parts numbers and descriptions must match the current parts price list.
 - b. The list must be typed or computer generated.
 - c. The list must state the reason(s) for the return.
 - d. The list must reference the sales order(s) or invoice(s) under which the items were originally purchased.
 - e. The list must include the name and phone number of the person requesting the RMA.
3. A copy of the Return Material Authorization must accompany the return shipment.
4. Freight is at the sender's expense. All parts must be returned freight prepaid to Multiquip's designated receiving point.

5. Parts must be in new and resalable condition, in the original Multiquip package (if any), and with Multiquip part numbers clearly marked.

6. The following items are not returnable:
 - a. Obsolete parts. (If an item is in the price book and shows as being replaced by another item, it is obsolete.)
 - b. Any parts with a limited shelf life (such as gaskets, seals, "O" rings, and other rubber parts) that were purchased more than six months prior to the return date.
 - c. Any line item with an extended dealer net price of less than \$5.00.
 - d. Special order items.
 - e. Electrical components.
 - f. Paint, chemicals, and lubricants.
 - g. Decals and paper products.
 - h. Items purchased in kits.

7. The sender will be notified of any material received that is not acceptable.
8. Such material will be held for five working days from notification, pending instructions. If a reply is not received within five days, the material will be returned to the sender at his expense.
9. Credit on returned parts will be issued at dealer net price at time of the original purchase, less a 15% restocking charge.
10. In cases where an item is accepted, for which the original purchase document can not be determined, the price will be based on the list price that was effective twelve months prior to the RMA date.
11. Credit issued will be applied to future purchases only.

PRICING AND REBATES

Prices are subject to change without prior notice. Price changes are effective on a specific date and all orders received on or after that date will be billed at the revised price. Rebates

for price declines and added charges for price increases will not be made for stock on hand at the time of any price change.

Multiquip reserves the right to quote and sell direct to Government agencies, and to Original Equipment Manufacturer accounts who use our products as integral parts of their own products.

SPECIAL EXPEDITING SERVICE

A \$35.00 surcharge will be added to the invoice for special handling including bus shipments, insured parcel post or in cases where Multiquip must personally deliver the parts to the carrier.

LIMITATIONS OF SELLER'S LIABILITY

Multiquip shall not be liable here under for damages in excess of the purchase price of the item with respect to which damages are claimed, and in no event shall Multiquip be liable for loss of profit or good will or for any other special, consequential or incidental damages.

LIMITATION OF WARRANTIES

No warranties, express or implied, are made in connection with the sale of parts or trade accessories nor as to any engine not manufactured by Multiquip. Such warranties made in connection with the sale of new, complete units are made exclusively by a statement of warranty packaged with such units, and Multiquip neither assumes nor authorizes any person to assume for it any other obligation or liability whatever in connection with the sale of its products. Apart from such written statement of warranty, there are no warranties, express, implied or statutory, which extend beyond the description of the products on the face hereof.

OPERATION AND PARTS MANUAL

HERE'S HOW TO GET HELP

PLEASE HAVE THE MODEL AND SERIAL
NUMBER *ON-HAND* WHEN CALLING

MQ POWER CORPORATE OFFICE

18910 Wilmington Ave. 800-421-1244
Carson, CA 90746 FAX: 310-632-2656
Email: mqpower@multiquip.com
Internet: www.mqpower.com

PARTS DEPARTMENT

800-427-1244 FAX: 800-672-7877
310-537-3700 FAX: 310-637-3284

SERVICE DEPARTMENT

800-835-2551 FAX: 310-638-8046
310-537-3700

TECHNICAL ASSISTANCE

800-835-2551 FAX: 310-638-8046

WARRANTY DEPARTMENT

800-835-2551, EXT. 279 FAX: 310-638-8046
310-537-3700, EXT. 279

Manufactured for Multiquip Inc.
by
DENYO CO., LTD, JAPAN

Your Local Dealer is:



MQ POWER

A Division of Multiquip Inc.

POST OFFICE BOX 6254

CARSON, CA 90749

310-537-3700 • 800-421-1244

FAX: 310-632-2656

E-mail: mqpower@multiquip.com

Internet: www.mqpower.com