

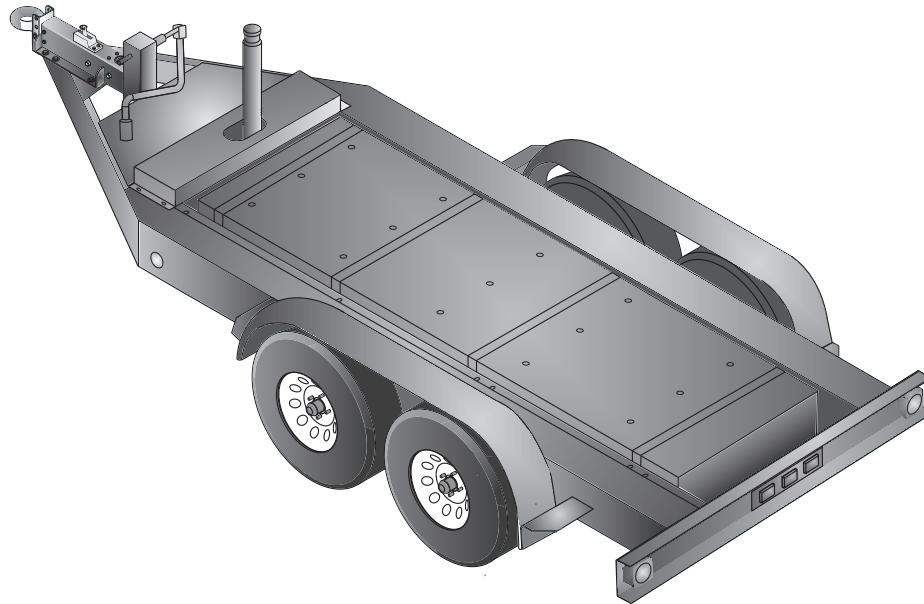

TRLR325XF Tandem Axle Trailer



TRLR325XF Technical Data			
Gross Vehicle Weight Rating (GVWR)	18,000 lbs	Tire Size	235/75R17.5 LR-H
Gross Axle Weight Rating (GAWR)	10,000 lbs (ea.)	Wheel Bolt Pattern	8 x 6.5
Actuator Rating	20,000 lbs	Tire Load Rating	6,005 lbs (ea.)
Pintle Eye Coupler Rating	20,000 lbs	Dimensions (LxWxH)	See Dimensions on reverse page

Standard Trailer Equipment

- Fits MQ Power Generator Models DCA250SSI, DCA300SSC, DCA300SSK
- Straight Tandem-axle Design with Leaf Spring Suspension
- H.D. Welded Steel Frame Construction
- Structural Channel for Generator Mounting and Support
- Integral Fuel Cell; Single-wall Steel Design; 300-gallon Capacity
- Replaceable, Bolt-on Hydraulic Brake Actuator
- Electric-actuated Drum Brakes (all axles)
- Hydraulic Uni-servo Drum Brakes - 12-inch Cluster (allows 15-20% braking in reverse)
- D.O.T. Steel Brake Lines, Brass Tees & Rubber Hydraulic Brake Hoses
- 4-hole Channel Allows 3-position, Adjustable Coupler Height; 4-inches O/A
- 3-inch Pintle-eye Coupler, Rated 20,000 lbs
- Heavy-duty, Tongue Mounted, Drop-leg Jack (rated 10,000 pound lift)
- Replaceable, Bolt-on Steel Fenders
- High-gloss Enamel Coated Frame, Channel, Actuator & Fenders
- D.O.T. Approved Tail Lamps, Stop Lamps, Turn Signal Lamps, Side Marker Lamps
- Weatherproof, Rubber Armored, 3-piece Trailer Light Wiring Harness



TRLR325XF Tandem Axle Trailer

Optional Trailer Equipment

- Hydraulic-actuated Drum Brakes (all axles) uses "Free Backing Solenoid" (requires special wiring harness and connector).
- Anti-Theft Wheel Lock
- Tongue Mounted Utility Storage Box
- Rear Stabilizer Stands
- Spare Tire with Locking Mount

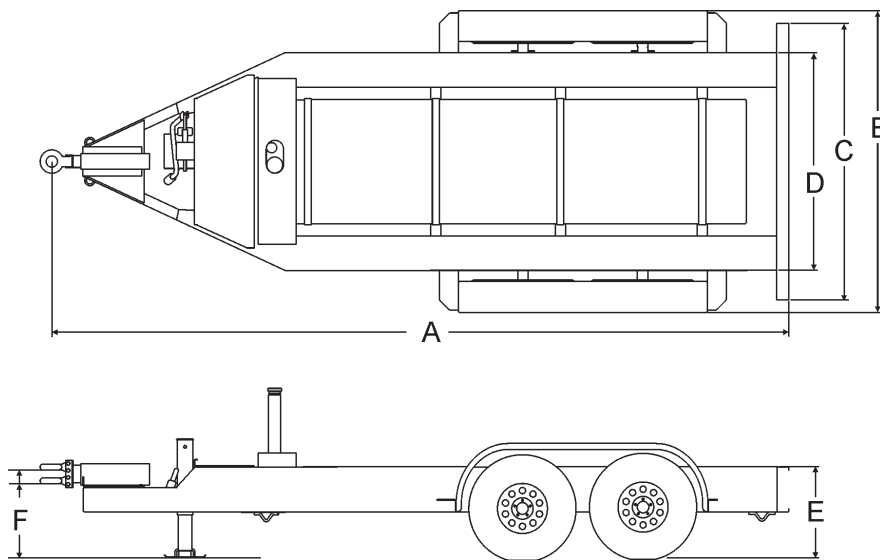

Trailer Dimensions						
A	B	C	D	E	F	
					Min.	Max.
234 in.	96 in.	88 in.	69 in.	33 in.	27 in.	31 in.
Trailer Weight						
without fuel				with fuel		
3,860 lbs (1,751 kg)*				5,990 lbs (2,717 kg)*		

* Weight is approximate

Your MQ Power dealer is:



MQ POWER
 POST OFFICE BOX 6254
 CARSON, CA 90749
 310-537-3700 • 800-421-1244
 FAX: 310-632-2656
 E-MAIL: mqpower@multiquip.com
 WEBSITE: www.mqpower.com