

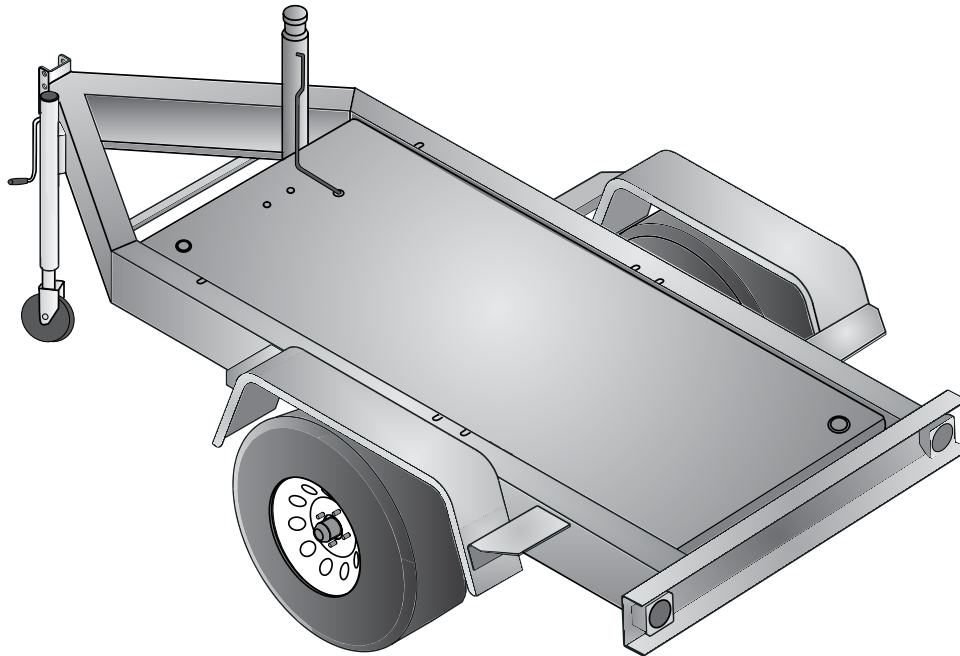

# TRLR50XF

## MQ POWER Single Axle Trailer



### TRLR50XF Technical Data

Gross Vehicle Weight Rating (GVWR) — 2,700 lbs (1225 kg)	Tire Size — ST175/80D13 LR-C
Gross Axle Weight Rating (GAWR) — 3,500 lbs (1,588 kg) (ea.)	Wheel Bolt Pattern — 5 Lug on 4.5 in
Coupler Rating — See coupler options on back page.	Tire Load Rating — 1,360 lbs/617 kg (ea.)

### STANDARD TRAILER EQUIPMENT

- Fits MQ Power Generator Models DCA20SPX, DCA25SSI
- Single-axle Design with Leaf Spring Suspension
- H.D. Welded Steel Frame Construction
- Integral Fuel Cell; Single-wall Steel Design, 41-gallon Capacity
- Formed Channel for Generator Mounting and Support
- 4-hole Channel Allows 3-position, Adjustable Coupler Height; 4-inches O/A
- Tongue Mounted Swivel Jack with Caster (rated 1,000 lb lift)
- Replaceable, Bolt-on Steel Fenders
- Powder Coat Paint Process including: Frame, Channel, Actuator & Fenders
- D.O.T. Approved Tail Lamps, Stop Lamps, Turn Signal Lamps, Side Marker Lamps



# TRLR50XF

## MQ POWER Single Axle Trailer

### OPTIONAL TRAILER EQUIPMENT

- Adjustable 2-inch Ball Coupler
- Adjustable 2 5/16-inch Ball Coupler
- Adjustable 3-inch Pintle Eye Coupler
- Rear Stabilizer Stands
- Tongue Mounted Utility Storage Box
- Spare Tire with Locking Mount
- Anti-Theft Wheel Lock

### Coupler Options

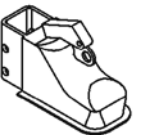
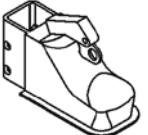
3" Pintle Eye 20,000 lbs. (9,072 kg)  #EE36264	
2" Ball Coupler 6,000 lbs. (2,722 kg) #29228  10,000 lbs. (4,536 kg) #EE43254	
2-5/16" Ball Coupler 14,000 lbs. (6,350 kg)  #EE43253	

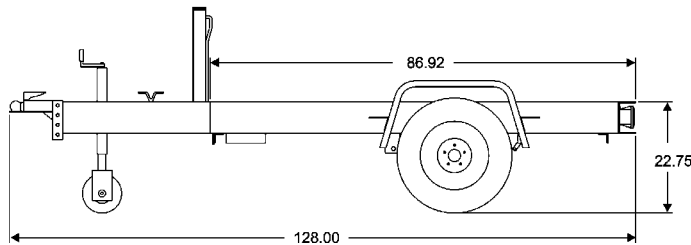
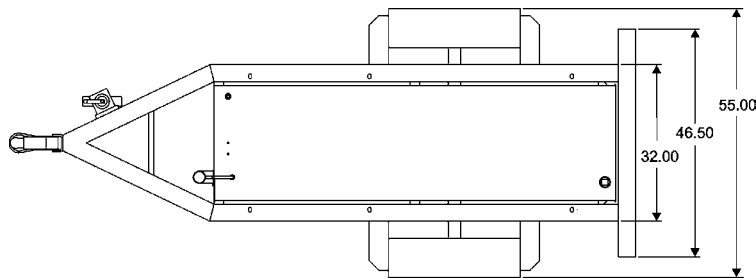

Trailer Weight	
Without fuel	With fuel
510 lbs. (231.5 kg)	801 lbs. (363.6 kg)

Your Multiquip dealer is:

