

# PARTS AND OPERATION MANUAL

# STOW

A DIVISION OF MULTQUIP INC.

## SV-SERIES VIBRATOR MOTOR

MODEL # \_\_\_\_\_

SERIAL # \_\_\_\_\_

Revision #2 (09/16/02)

© COPYRIGHT 2002, MULTQUIP INC.

**STOW**  
A DIVISION OF MULTQUIP INC.

**STOW CONSTRUCTION EQUIPMENT**

A DIVISION OF MULTQUIP INC.

POST OFFICE BOX 6254

CARSON, CA 90749

310-537-3700 • 888-252-STOW [888-252-7869]

FAX: 310-537-1986 • FAX: 800-556-1986

E-MAIL: stow@multiquip.com • WWW: stowmfg.com

**PARTS DEPARTMENT:**

800-427-1244

FAX: 800-672-7877

**SERVICE DEPARTMENT/TECHNICAL ASSISTANCE:**

800-478-1244

FAX: 310-631-5032

**P/N 36199**



# WARNING



## **CALIFORNIA — Proposition 65 Warning**

Engine exhaust and some of its constituents, and some dust created by power sanding, sawing, grinding, drilling and other construction activities contains chemicals known to the State of California to cause cancer, birth defects and other reproductive harm. Some examples of these chemicals are:

- Lead from lead-based paints.
- Crystalline silica from bricks.
- Cement and other masonry products.
- Arsenic and chromium from chemically treated lumber.

Your risk from these exposures varies, depending on how often you do this type of work. To reduce your exposure to these chemicals: **ALWAYS** work in a well ventilated area, and work with approved safety equipment, such as dust masks that are specially designed to filter out microscopic particles.

## **HERE'S HOW TO GET HELP**

*PLEASE HAVE THE MODEL AND SERIAL NUMBER  
ON-HAND WHEN CALLING*

### ***PARTS DEPARTMENT***

*800-427-1244 or 310-537-3700*

*FAX: 800-672-7877 or 310-637-3284*

### ***SERVICE DEPARTMENT/TECHNICAL ASSISTANCE***

*800-478-1244 or 310-537-3700*

*FAX: 310- 537-4259*

### ***WARRANTY DEPARTMENT***

*888-661-4279, or 310-661-4279*

*FAX: 310- 537-1173*

### ***MAIN***

*800-421-1244 or 310-537-3700*

*FAX: 310-537-3927*

# SV-SERIES VIBRATOR MOTOR—TABLE OF CONTENTS

Here's How To Get Help .....	3
Table Of Contents .....	4
Parts Ordering Procedures .....	5
Safety Message Alert Symbols .....	6
Rules For Safe Operation .....	7-9

## **MQ STOW — SV-SERIES VIBRATOR MOTOR**

Specifications .....	10
Decals .....	11
Preparation & Operation .....	12
Operation .....	13
Maintenance .....	14
Troubleshooting .....	15
Vibrator Motor Assembly .....	16-19
Terms and Conditions of Sale .....	20

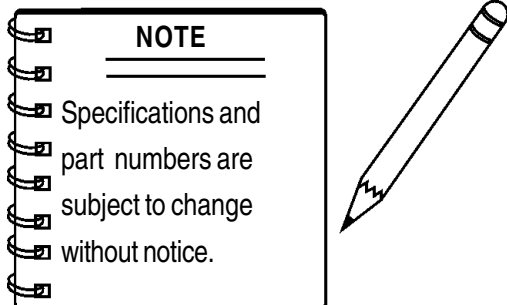

# SV-SERIES VIBRATOR MOTOR— PARTS ORDERING PROCEDURES

- Dealer account number
- Dealer name and address
- Shipping address (if different than billing address)
- Return fax number
- Applicable model number
- Quantity, part number and description of each part
- Specify preferred method of shipment:
  - UPS Ground
  - UPS Second Day or Third Day\*
  - UPS Next Day\*
  - Federal Express Priority One (please provide us with your Federal Express account number)\*
  - Airborne Express\*
  - Truck or parcel post

*\*Normally shipped the same day the order is received, if prior to 2PM west coast time.*

## Earn Extra Discounts when you order by FAX!

All parts orders which include complete part numbers and are received by fax qualify for the following extra discounts:

<u>Number of line items ordered</u>	<u>Additional Discount</u>
1-9 items	3%
10+ items**	5%

### Get special freight allowances when you order 10 or more line items via FAX! \*\*

- UPS Ground Service at no charge for freight
- UPS Third Day Service at one-half of actual freight cost

No other allowances on freight shipped by any other carrier.

\*\*Common nuts, bolts and washers (all items under \$1.00 list price) do not count towards the 10+ line items.

\*DISCOUNTS ARE SUBJECT TO CHANGE\*

Fax order discount and UPS special programs revised June 1, 1995

**Extra Fax Discount  
for Domestic USA  
Dealers Only**

**Up to 5%  
extra savings!**

**UPS  
Special**  
For faxed orders only

**Now! Direct TOLL-FREE access  
to our Parts Department!**

Toll-free nationwide:

800-421-1244

Toll-free FAX:

800/6-PARTS-7 • 800-672-7877

# SV-SERIES VIBRATOR MOTOR— SAFETY MESSAGE ALERT SYMBOLS

## FOR YOUR SAFETY AND THE SAFETY OF OTHERS!

Safety precautions should be followed at all times when operating this equipment. Failure to read and understand the Safety Messages and Operating Instructions could result in injury to yourself and others.

### NOTE

This Owner's Manual has been developed to provide complete instructions for the safe and efficient operation of the MQ STOW SV-SERIES VIBRATOR MOTOR.

**Before using this VIBRATOR MOTOR, ensure that the operating individual has read and understands all instructions in this manual.**

## SAFETY MESSAGE ALERT SYMBOLS

The three (3) Safety Messages shown below will inform you about potential hazards that could injure you or others. The Safety Messages specifically address the level of exposure to the operator, and are preceded by one of three words: **DANGER**, **WARNING**, or **CAUTION**.



**DANGER:** You **WILL** be **KILLED** or **SERIOUSLY** injured if you **DO NOT** follow directions.



**WARNING:** You **CAN** be **KILLED** or **SERIOUSLY** injured if you **DO NOT** follow directions.



**CAUTION:** You **CAN** be injured if you **DO NOT** follow directions.

Potential hazards associated with SV-SERIES VIBRATOR MOTOR operation will be referenced with "**Hazard Symbols**" which appear throughout this manual, and will be referenced in conjunction with Safety "**Message Alert Symbols**".

## HAZARD SYMBOLS



### Accidental Starting

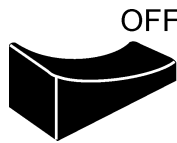

**ALWAYS** place the motor ON/OFF switch in the **OFF** position, when the Vibrator Motor is not in use.



### Sight and Hearing hazard

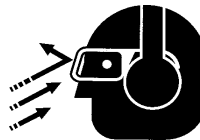

**ALWAYS** wear approved eye and hearing protection.



### Burn Hazard

**High Temperatures** – Unplug the machine and allow to **cool** before performing service and maintenance functions. Contact with **hot!** components can cause serious burns.



### Explosive Fuel

**NEVER** operate the Vibrator Motor in an explosive atmosphere or near combustible materials. An explosion or fire could result causing severe **bodily harm or even death**.

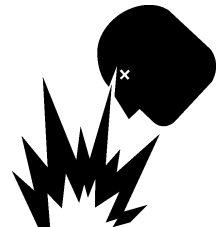

# SV-SERIES VIBRATOR MOTOR— RULES FOR SAFE OPERATION

## CAUTION:



Failure to follow instructions in this manual may lead to serious injury. This equipment is to be operated by trained and qualified personnel only! This equipment is for industrial use only.

The following safety guidelines should always be used when operating the SV-SERIES VIBRATOR MOTOR.

## SAFETY

- **DO NOT** operate or service this equipment before reading this entire manual.
- **ALWAYS** use proper lifting techniques when using the the Vibrator Motor, flexible shaft and vibrator head assembly.
- **ALWAYS** check to make sure that the operating area is clear before starting the Vibrator Motor.
- **NEVER** leave the machine *unattended* while running.
- Keep the Vibrator Motor in proper running condition.
- Make sure that there is no buildup of concrete, grease, oil or debris on the Vibrator Motor.
- Fix damage to the Vibrator Motor immediately and always replace broken parts.
- This equipment should not be operated by persons under 18 years of age.
- **NEVER** operate this equipment without proper protective clothing, shatterproof glasses, steel-toed boots and other protective devices required by the job.



- **NEVER** operate this equipment when not feeling well due to fatigue, illness or taking medicine.



- **NEVER** operate this equipment under the influence of drugs or alcohol.



- **ALWAYS** check the Vibrator Motor for loosened threads or bolts before starting.
- **NEVER** use accessories or attachments, which are not recommended by Stow for this equipment. Damage to the equipment and/or injury to user may result.

## EMERGENCIES

- **ALWAYS** know the location of the nearest *fire extinguisher*.



- **ALWAYS** know the location of the nearest and *first aid kit*.



- In emergencies *always* know the location of the nearest phone or *keep a phone on the job site*. Also know the phone numbers of the nearest *ambulance, doctor* and *fire department*. This information will be invaluable in the case of an emergency.

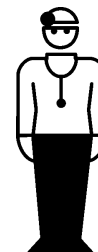

# SV-SERIES VIBRATOR MOTOR— RULES FOR SAFE OPERATION

## SAFETY INSTRUCTIONS

For the safety of yourself and others working around you, it is **EXTREMELY** important that you observe the following rules:

- **NEVER** operate a vibrator motor while under the influence of drugs, alcohol, or medications that may impair the senses or reactions.
- Dress properly. Wear appropriate clothing and protective safety equipment. Wear clothing that will not likely become caught in the equipment or snag on the forms. Eye, hand, hearing, and foot safety equipment is required.
- Keep untrained personnel away. **DO NOT** let visitors contact the vibrator unit. All visitors should be kept away from the work area.
- **ALWAYS** disconnect the motor from the power source when not in use, before servicing, and when changing flexible shafting and vibrator heads.
- **DO NOT** abuse the motor cord.
- **NEVER** carry the motor by the cord. Use the carrying frame.
- **DO NOT** yank the cord to disconnect it from the receptacle. Grasp the plug itself to disconnect it.
- Keep the cord from heat, oil, and sharp objects.
- Avoid unintentional starting.
- **DO NOT** carry plugged-in motor with finger on the switch.
- Be sure switch is in the "OFF" position before plugging the motor into a power source.
- **DO NOT** overload the motor. It will do a better and safer job at the rate for which it was designed.
- **DO NOT** expose vibrator motor to rain.
- **DO NOT** use vibrator motor in damp or wet locations without proper electrical circuits.
- **DO NOT** use the vibrator in the presence of flammable liquids or gases.
- Keep work area well lit.
- Keep work area clean. A cluttered area invites injuries.
- **DO NOT** overreach. Keep proper footing and balance at all times.
- Secure forms. Make sure the form work is well made and braced to withstand the stresses made by vibration.
- The use of any attachment or accessory not intended for use with this vibrator motor may present a risk of injury to the operator or other personnel.
- Maintain tools with care.
- Keep vibrator motor clean for better and safer operation.
- Inspect motor cord periodically and if damaged, have it repaired by an authorized service facility.
- Use only factory authorized identical **replacement parts**.
- Check for damaged parts.
- Before each use **ALWAYS** check the motor to make certain there are no damaged parts, and that all parts function properly, (examples: switch, cord housing). If any damage or malfunctioning parts are found, have them repaired or replaced by an authorized service facility.
- **NEVER** use the motor with a defective switch. If the switch does not turn the motor "ON" or "OFF", have it replaced before using the motor.
- Before plugging the motor into a power source, **ALWAYS** remove any wrenches or other tools from the motor, shaft, and head that were used for assembly.
- **ALWAYS** use the correct tool for the job.
- **DO NOT** force the motor and head to do the job of a larger motor and head.
- **DO NOT** use this motor for anything other than its intended use.
- Store idle vibrator motor. When not in use, motor should be stored in a dry, safe storage area.
- **SAVE THESE INSTRUCTIONS.** Keep these instructions in a safe place for future reference.

## WARNING!



When using electric tools, basic safety precautions should **ALWAYS** be followed to reduce the risk of fire, electric shock, and personal injury.

1. Know your concrete vibrator. Read this instruction manual. Learn the vibrator's applications, limitations, and specific potential hazards peculiar to this tool.
2. Guard against electrical shock.
3. Prevent body contact with grounded surfaces. (For example: pipes, reinforcing bar, etc.)

# SV-SERIES VIBRATOR MOTOR— RULES FOR SAFE OPERATION

- Use a protection wiring device, such as a Ground Fault Circuit Interrupter, for the protection of personnel.
- This concrete vibrator motor (230V) is equipped with a 3-conductor cord, and a 3-prong grounding type plug to fit the proper grounding type receptacle. The green conductor in the cord is the ground wire. **NEVER** connect the green wire to a live terminal. See (Figure 1) for proper grounding methods. (230V ONLY)

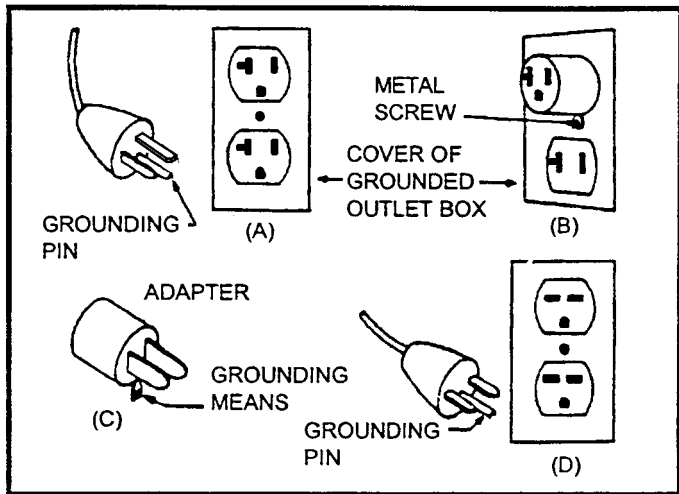

Figure 1. Grounding Methods (230V) Typical

- Use of extension cords.
  - **MAKE CERTAIN** the power cord/extension cord is free from damage, and that the grounding circuit is operational. Repair or replace all damaged cords and grounding units.
  - When extending the cord, **MAKE CERTAIN** not to submerge the connection in water. To avoid the possibility of electric shock, water-tight connections should always be made.
  - Use only extension cords that are intended for outdoor use and so marked.
  - Use only the gauge wire and length of cord recommended for the motor size. If in doubt, go to the next heavier gauge. (The smaller the gauge number, the heavier the cord.)
  - See (Table 1) for recommended extension cord sizes.

TABLE 1. Extension Cord Sizes

Ampere Rating Range	Volts	Length of Cord in Feet					
	115V	25 Ft.	50 Ft.	100 Ft.	150 Ft.	200 Ft.	250 Ft.
		230V	50 Ft.	100 Ft.	200 Ft.	300 Ft.	400 Ft.
0 - 2		18	18	18	16	16	14
2 - 3		18	18	16	14	14	12
3 - 4		18	18	16	14	12	12
4 - 5		18	18	14	12	12	10
5 - 6		18	16	14	12	10	10
6 - 8		18	16	12	10	10	8
8 - 10		18	14	12	10	8	8
10 - 12		16	14	10	8	8	6
12 - 14		16	12	10	8	6	6
14 - 16		16	12	10	8	6	6
16 - 18		14	12	8	8	6	4
18 - 20		14	12	8	6	6	4

## WARNING!



**DO NOT REMOVE THE GROUNDING PIN FROM THE PLUG. (230V ONLY)**

## WARNING!



**ALWAYS** use a grounded 3-wire extension cord that has a 3-prong grounding plug, and a 3-pole receptacle that accepts the plug on the concrete vibrator motor. (230V ONLY)

## WARNING!



**MAKE CERTAIN** the motor is connected to a **GROUND FAULT CIRCUIT INTERRUPTER** to protect the operator from possible electric shock. (230V ONLY)

## CAUTION!



Use of an extension cord with a wire gauge smaller than, or length longer than that stated previously could result in reduced motor performance and/or damage to the motor or extension cord due to overheating.

# SV-SERIES VIBRATOR MOTOR— SPECIFICATIONS

## Specifications

TABLE 2. SPECIFICATIONS					
Model	SV-1	SV-2/SV-2E		SV-3/SV-3E	
Horsepower	1HP	2HP		3HP	
Length	13.5"	13.5"		13.5"	
Width	8.75	8.75"		8.75"	
Height	8.75"	8.75"		8.75"	
Weight	11 LBS.	12.5 LBS.		13.5 LBS.	
RPM (No Load)	18,000 RPM	18,000 RPM		18,000 RPM	
Volts	115VAC	115VAC	230VAC	115VAC	230VAC
Amps	1-3A	2-3.5A	1-1.75A	3-5A	1.5-2.5A
Hertz	60Hz	60Hz		60Hz	

# SV-SERIES VIBRATOR MOTOR— DECALS

## Machine Decals



P/N 30166-001



P/N 30242-001



P/N 30166-002



P/N 20215-001



P/N 30166-004

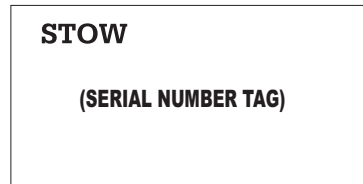

CONTACT SERVICE DEPARTMENT



P/N 30166-005



P/N 30166-007

Figure 2. Decals, SV-1, SV-2 and SV-3

# SV-SERIES VIBRATOR MOTOR—PREPARATION & OPERATION



Before using your Vibrator Motor, read and fully understand all of the safety and operating instructions not only for the motor, but also for the flexible shafting and the head that will be used with the motor.

1. The vibrator motor, flexible shafting, and heads are shipped from the factory ready to use. Connect per instruction bulletins.
2. Use only the combination of flexible shafting and heads shown below in Table 3.

Table 3. Shaft Sizes			
MODEL	SHAFT	HEAD SIZE	MAX. SHAFT LENGTH
SV-1	314V	900 1000 1300	21 FT.
SV-2	382V	1400 1700	28 FT.
		2100	21 FT.
SV-3	382V	1400 1700 2100 2600	35 FT.

3. To connect the 382V flexible shafting to the vibrator motor see (Figure 3).

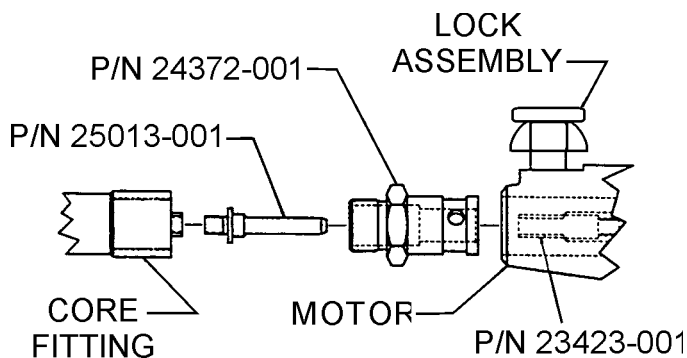

Figure 3. Shafting to Motor Connection

## WARNING!



**MAKE CERTAIN** the motor is disconnected from the power source and the switch is in the "OFF" position.

4. Slide the core out of the casing far enough to thread the spindle (p/n 25013-001) into the core fitting and tighten. A pair of pliers and a wrench can be used to tighten the connection. It is important that this connection be tight. If it is not, the torque of the motor plus the load of the head will jam the two fittings together making it extremely hard to loosen them for disassembly.
5. Thread the shaft coupling (P/N 24372-001) into the casing ferrule and tighten.
6. Pull up on the lock pin and slide the shaft assembly into the front motor bearing housing and release the lock pin. Give the shaft assembly a twist to make sure that the lock pin is seated in one of the 3 tapered holes in the shaft coupling.
7. Clean the mating parts threads with Locquic Primer "T". Allow to dry several minutes before applying a ring of Loctite No. 271 or equivalent to the middle of the casing threads. Screw the head tightly to the casing and wait 1 hour before using. Threads are left-hand; turn counter-clockwise to tighten.

## CAUTION!



If the shaft begins to helix (buckle) excessively during operation, stop and investigate. This is an indication of an overload condition.

## CAUTION!



The vibrator head is cooled by the concrete. Operation of the vibrator head in air longer than 2 minutes at a time will cause overheating of the bearings which will result in premature head failure.

## CAUTION!



Visually inspect the air intake and exhaust frequently to make sure the motor has sufficient air for cooling.

# SV-SERIES VIBRATOR MOTOR — OPERATION

## THEORY OF CONCRETE VIBRATION

This **VIBRATOR MOTOR** is designed for the **compaction** of concrete by removal of air pockets and voids.

The action of vibration is to set the particles in the fresh concrete in motion, thereby reducing the friction between the particles and giving the mixture the mobile quality of a thick fluid so that gravity and the displacement of entrapped air will cause it to settle easily into place.

By thus consolidating the concrete quickly, "stiffer" or "drier" mixes can be poured than would otherwise be possible. It has been proven that (up to a point) the drier the concrete, (that is, the less water in it), the better the quality throughout and the greater the strength.

Drier mixes also make the concrete more water tight, increase resistance to weathering, and create a better bond between concrete and reinforcement. Because vibration causes much of the entrapped air in the concrete to rise to the surface, honeycombing is prevented. Also, vibration eliminates most of the air pockets between the concrete and the vertical forms.

## SV-SERIES VIBRATOR MOTOR OPERATION

**Read** all the safety instructions carefully. Safety instructions will be found throughout this manual and on the Vibrator Motor. Keep all safety information in good, readable condition.

1. Make certain that the flexible shaft is properly attached to the motor and the head to the flexible shaft.
2. Use the flexible shaft in as straight a position as possible.
3. **DO NOT** bend the flexible shaft sharply at any point. Sharp bends may cause a permanent kink, requiring early replacement of the flexible shaft.
4. With the Stow vibrator motor properly plugged into the correct power source, turn the **ON/OFF** switch to the "**ON**" position and proceed to insert the vibrator into the concrete.
5. The concrete is normally placed in the forms in layers about 12 to 18 inches thick in a manner which forms a fairly level surface. The vibrator head is inserted vertically into the top of the pile.
6. **DO NOT** insert the head into the side of the pile to make the concrete flow as this practice can cause segregation of the aggregate from the mortar. When the surface has become fairly level, the head should be immersed and generally moved in the pattern shown in Figure 4.

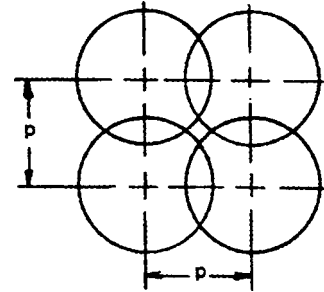
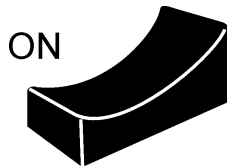

**Figure 4. Compaction Coverage with 50% Radial Overlap**

**Table 4. Compaction Coverage**

Head	900	1000	1300	1400	1700	2100	2600
P-Dimension	4"	5-1/2"	8"	8"	12"	14"	18"

7. Immerse the head for 5 to 10 seconds, (until air stops rising), and then withdraw it slowly to let the concrete fill the void left by the head.
8. The head should be completely below the surface when vibrating to keep the head cool.
9. When vibrating a thin horizontal slab, the head can be used in a horizontal position.

# SV-SERIES VIBRATOR MOTOR — MAINTENANCE

## MAINTENANCE

### CAUTION!



Before performing any maintenance on this unit, **ALWAYS MAKE CERTAIN** that the switch is in the "OFF" position and the power cord is disconnected from the power source.

This is a universal motor and it will run at approximately its rated speed if the motor and its attached equipment are properly operated and maintained.

1. Have repair work performed by an authorized service facility, using identical or manufacturer approved replacement parts.
2. This motor uses sealed bearings and does not require lubrication.
3. Visually inspect the motor daily before use for defective or missing parts, and have repairs made before use.
4. Inspect brushes frequently and replace when they become worn to a length of 3/8".
5. Keep air inlet and air exit louvers clean and free of concrete and debris. Failure to do so will result in rapid motor overheating and parts failure.
6. Clean air filter as needed. If unit is used in high dust areas, filter will have to be cleaned more often.
7. Use wrench to tighten brush caps. The brush cap must be tight enough that the brush holder does not move.
8. Should complete disassembly of the motor become necessary, it will be much easier if all internal components are built into (Left) housing half P/N 29944-302. Using the exploded view as a guide, place the anti-rotation pin side of the field into the slot provided in the -302 housing. See the end of the maintenance section for proper field orientation. This anti-rotation pin along with the armature bearing housings will help align the entire motor. Next, place (Right) housing half P/N 29944-301 down on top of the -302 half and snap them together, (the lip around the housing should "pop" as it aligns). Holding the assembled halves tightly, flip the entire unit over so that the screws can be inserted.
9. The 382V flexible shaft requires cleaning and relubrication every 100 hours of operation. Refer to 382V flexible shafting operating instructions for maintenance instructions.

10. Vibrator heads should be inspected and relubricated every 100 hours of operation. Follow the instructions for vibrator heads.

### NOTE

Heat should be used to break down the loctite while you unthread the head from the shaft. This will prevent possible damage to the threads from the loctite.

### Field Orientation (Figure 5) (when viewed from the rear of the motor)

1. The field should be positioned so the wires coming out of the field are have 3 wires coming out of the upper field shoe and one wire coming out of the lower field shoe.
2. The 2 long leads from the upper shoe should be routed through the housing to the switch.
3. The third shorter lead from the upper shoe should be connected to the right-hand brush holder when viewed from the rear of the motor.
4. The single lead from the lower shoe should be connected to the left -hand brush holder when viewed from the rear of the motor.
5. After assembling complete motor, check the direction of shaft rotation. When viewed from the front or drive end of the motor the shaft should turn in a counter-clockwise direction.

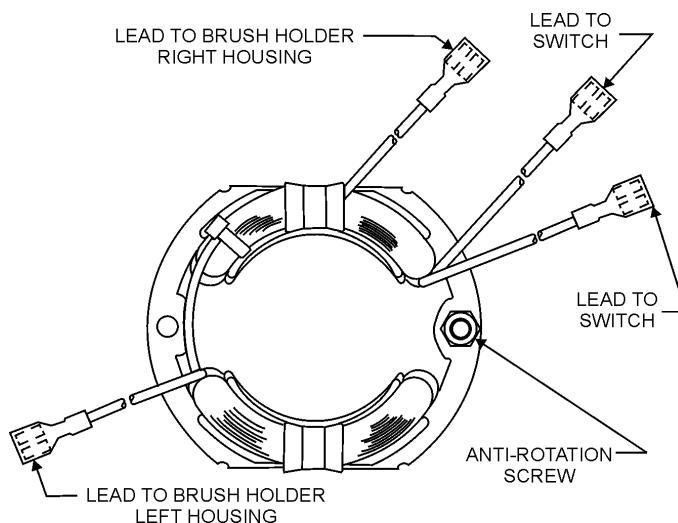

Figure 5. Field Orientation

# SV-SERIES VIBRATOR MOTOR — TROUBLESHOOTING

**TABLE 5. TROUBLESHOOTING**

<b>SYMPTOM</b>	<b>POSSIBLE PROBLEM</b>	<b>SOLUTION</b>
Motor does not start.	Burnt out switch (rare). One or more internal connections open.	Replace or complete connections as needed.
Housing halves do not seat together properly	Pinched wire.	Use screw driver to adjust wires. <b>MAKE CERTAIN</b> not to damage the insulation on the wires.
Growling/scraping noise from armature and field area.	Rubbing between armature and field.	Reassemble motor components in housing 29944-302. Spin armature on its bearings and feel for rubbing between the field and armature. If rubbing cannot be eliminated, contact the manufacturer.
Rattling noise from forward bearing housing area.	Forward bearing spinning inside its housing.	Secure outer ring of bearing with Loctite RC-609 (or equivalent) to the inner bearing housing surface.

# SV-SERIES — VIBRATOR MOTOR ASSY.

VIBRATOR MOTOR ASSY.

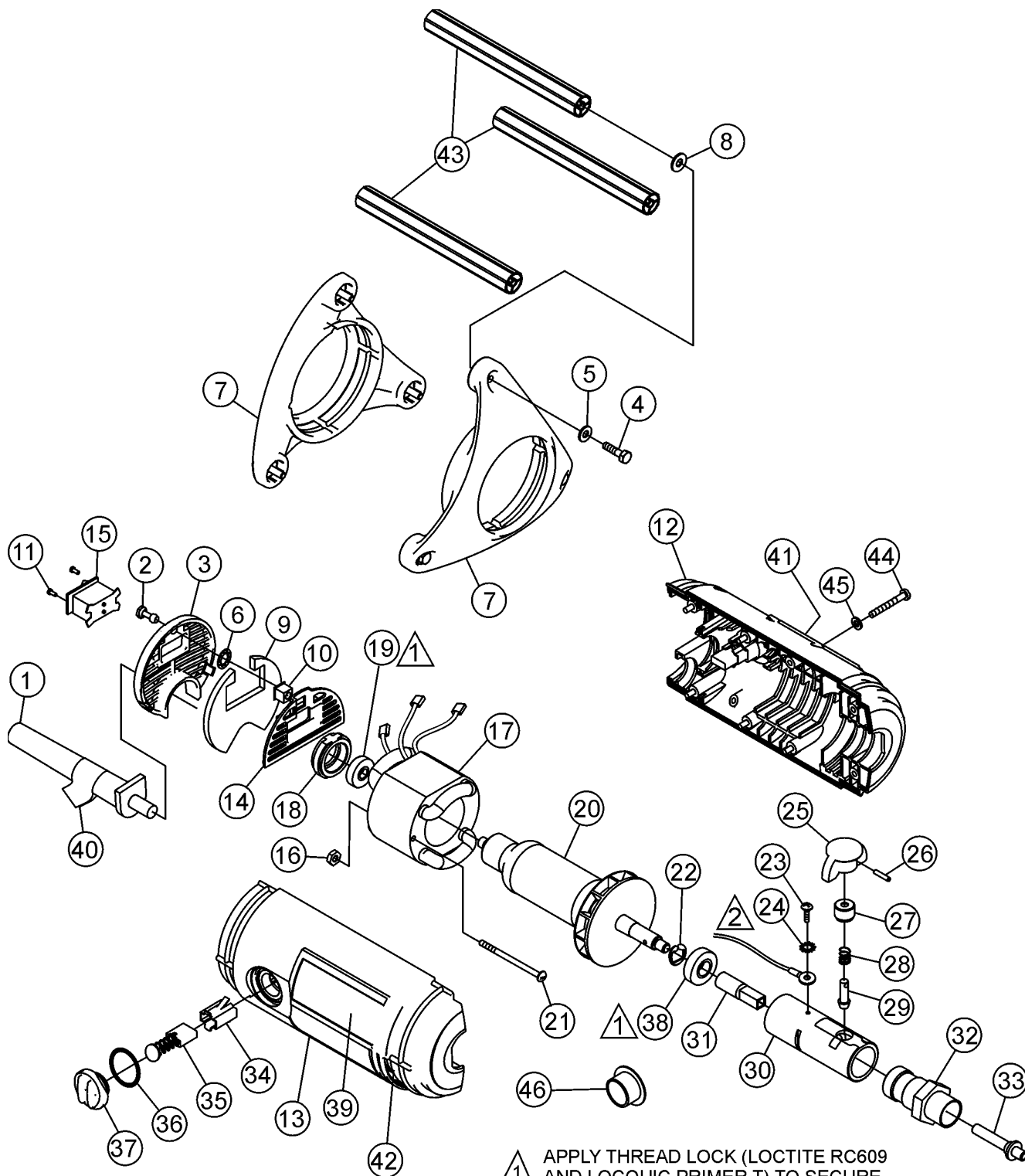

▲ 1 APPLY THREAD LOCK (LOCTITE RC609 AND LOCQUIC PRIMER T) TO SECURE FORWARD AND REAR BEARINGS INTO THE BEARING HOUSINGS. (ITEMS 19 AND 38)

▲ 2 GROUND WIRE (230V -621 ONLY)

# SV-SERIES — VIBRATOR MOTOR ASSY.

## VIBRATOR MOTOR ASSY.

<u>NO.</u>	<u>PART NO.</u>	<u>PART NAME</u>	<u>QTY.</u>	<u>REMARKS</u>
1	30205-401	CORD, 115V	1	
1	30214-502	CORD, 230V	1	
2	29982-001	STUD, FASTENER	1	
3	29955-001	BACK PLATE	1	
4	30190-016	SCREW, HHCS M6 X 16	6	
5	30245-004	WASHER, FLAT 1/4"	6	
6	30201-001	WASHER, RETAINER	1	
7	29945-001	END CAP	2	
8	10136	WASHER, FLAT	6	
9	29980-001	AIR FILTER	1	
10	29983-001	NUT, CAGE 1/4 TURN	1	
11	15164-005	POP RIVET	2	
12	29944-301	HOUSING, RIGHT	1	
13	29944-302	HOUSING, LEFT	1	
14	29954-001	PLATE, MTG SWITCH	1	
15	23366-001	SWITCH	1	
16	10019	NUT, NYLOC	1	
17	29942-411	FIELD, 1HP 115V SV-1	1	
17	29942-421	FIELD, 1HP 230V SV-1	1	
17	29942-412	FIELD, 2HP 115V SV-2	1	
17	29942-422	FIELD, 2HP 230V SV-2	1	
17	29942-413	FIELD, 3HP 115V SV-3	1	
17	29942-423	FIELD, 3HP 230V SV-3	1	
18	29950-001	HOUSING, REAR BEARING	1	
19	14611-001	BEARING, REAR	1	
20	29943-411	ARMATURE, 1HP 115V SV-1	1	
20	29943-421	ARMATURE, 1HP 230V SV-1	1	
20	29943-412	ARMATURE, 2HP 115V SV-2	1	
20	29943-422	ARMATURE, 2HP 230V SV-2	1	
20	29943-413	ARMATURE, 3HP 115V SV-3	1	
20	29943-423	ARMATURE, 3HP 230V SV-3	1	
21	06827-044	SCREW, 10-32 X 2-3/4	1	
22	10096-002	SNAP RING, EXT	1	
23	16784-004	SCREW, 8-32 X 1/4	1	
24	07027-013	WASHER, STAR #8	1	
25	29946-001	KNOB	1	
26	07502-016	ROLL PIN, 5/32 X 1	1	
27	29948-001	HOUSING, SPRING	1	
28	23432-001	SPRING	1	
29	29947-001	PIN, QD LOCK	1	
30	29949-001	HOUSING, FRONT BEARING	1	
31	23429-001	FITTING, ADAPTER	1	
32	29979-001	COUPLING, SHAFT 314V (SV-1)	1	
32	24372-001	COUPLING, SHAFT 382V (SV-2 & SV-3)	1	
33	29957-001	SPINDLE 314V (SV-1)	1	
33	25013-001	SPINDLE 382V (SV-2 & SV-3)	1	

# SV-SERIES — VIBRATOR MOTOR ASSY.

VIBRATOR MOTOR ASSY.

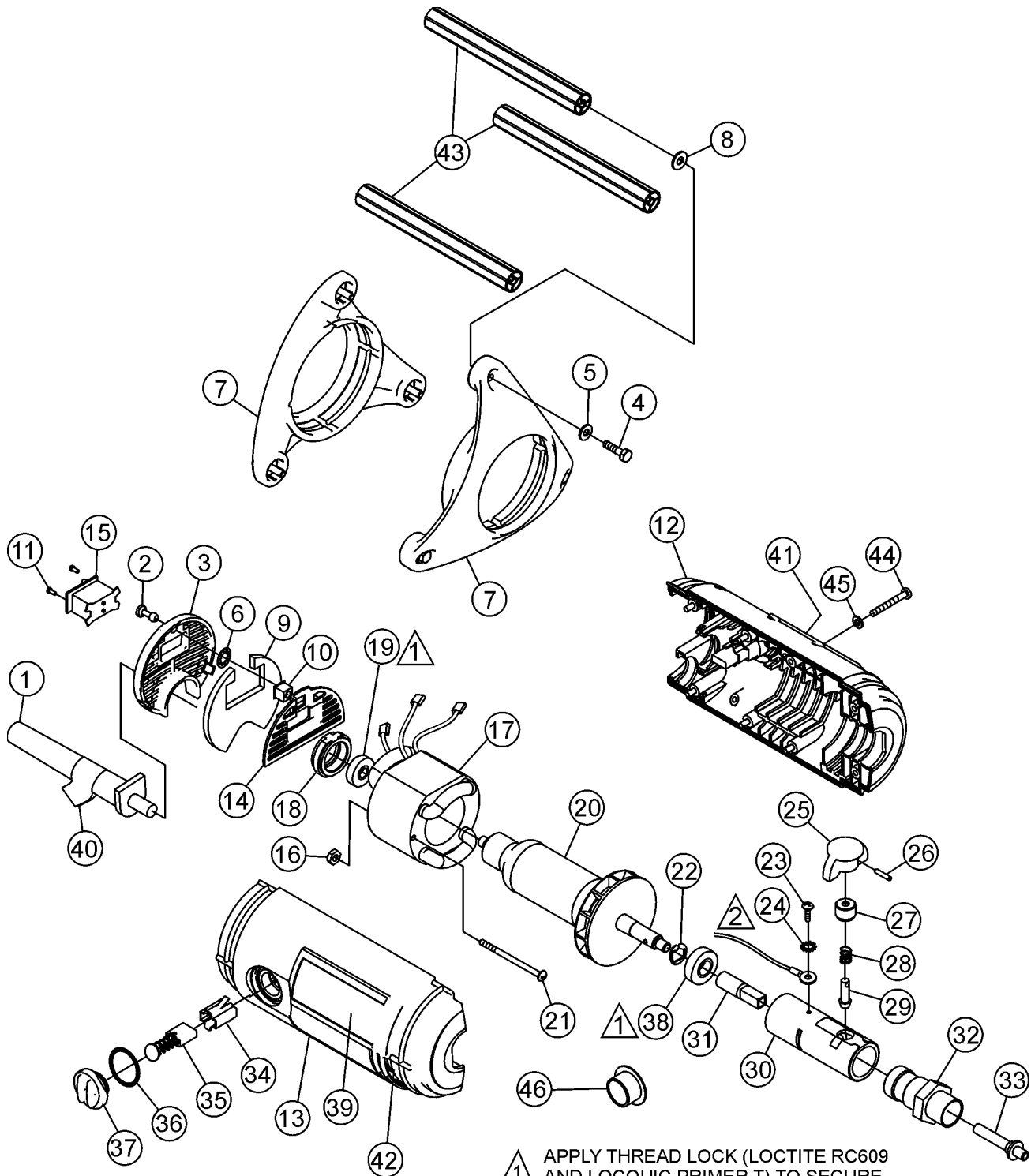

△ 1 APPLY THREAD LOCK (LOCTITE RC609 AND LOCQUIC PRIMER T) TO SECURE FORWARD AND REAR BEARINGS INTO THE BEARING HOUSINGS. (ITEMS 19 AND 38)

△ 2 GROUND WIRE (230V -621 ONLY)

## SV-SERIES — VIBRATOR MOTOR ASSY.

### VIBRATOR MOTOR ASSY.

<u>NO.</u>	<u>PART NO.</u>	<u>PART NAME</u>	<u>QTY.</u>	<u>REMARKS</u>
34	23361-001	BRUSH HOLDER	2	
35	30264-401	BRUSH ASM	2	
36	22094-028	O-RING	2	
37	29952-001	CAP, BRUSH	2	
38	14611-003	BEARING, FRONT	1	
39	30166-001	DECAL, SV-1 115V	1	
39	30166-002	DECAL, SV-1 230V	1	
39	30166-004	DECAL, SV-2 115V	1	
39	30166-005	DECAL, SV-2 230V	1	
39	30166-007	DECAL, SV-3	1	
40	25215-001	DECAL, WARNING	1	
41	30242-001	DECAL, STOW	1	
42		TAG, SERIAL NUMBER .....	1	..... CONTACT SALES DEPT.
43	29951-001	TUBE HANDLE	3	
44	29987-040	SCREW, M5 X 40MM	8	
45	29988-005	WASHER, LOCK M5	8	
46	11534-018	PROTECTOR, PLASTIC	1	

**PAYMENT TERMS**

Terms of payment for parts are net 10 days.

**FREIGHT POLICY**

All parts orders will be shipped collect or prepaid with the charges added to the invoice. All shipments are F.O.B. point of origin. Multiquip's responsibility ceases when a signed manifest has been obtained from the carrier, and any claim for shortage or damage must be settled between the consignee and the carrier.

**MINIMUM ORDER**

The minimum charge for orders from Multiquip is \$15.00 net. Customers will be asked for instructions regarding handling of orders not meeting this requirement.

**RETURNED GOODS POLICY**

Return shipments will be accepted and credit will be allowed, subject to the following provisions:

1. A Returned Material Authorization must be approved by Multiquip prior to shipment.
2. To obtain a Return Material Authorization, a list must be provided to Multiquip Parts Sales that defines item numbers, quantities, and descriptions of the items to be returned.
  - a. The parts numbers and descriptions must match the current parts price list.
  - b. The list must be typed or computer generated.
  - c. The list must state the reason(s) for the return.
  - d. The list must reference the sales order(s) or invoice(s) under which the items were originally purchased.
  - e. The list must include the name and phone number of the person requesting the RMA.
3. A copy of the Return Material Authorization must accompany the return shipment.

4. Freight is at the sender's expense. All parts must be returned freight prepaid to Multiquip's designated receiving point.
5. Parts must be in new and resalable condition, in the original Multiquip package (if any), and with Multiquip part numbers clearly marked.
6. The following items are not returnable:
  - a. Obsolete parts. (If an item is listed in the parts price book as being replaced by another item, it is obsolete.)
  - b. Any parts with a limited shelf life (such as gaskets, seals, "O" rings, and other rubber parts) that were purchased more than six months prior to the return date.
  - c. Any line item with an extended dealer net price of less than \$5.00.
  - d. Special order items.
  - e. Electrical components.
  - f. Paint, chemicals, and lubricants.
  - g. Decals and paper products.
  - h. Items purchased in kits.
7. The sender will be notified of any material received that is not acceptable.
8. Such material will be held for 5 working days from notification, pending instructions. If a reply is not received within 5 days, the material will be returned to the sender at his expense.
9. Credit on returned parts will be issued at dealer net price at time of the original purchase, less a 15% restocking charge.
10. In cases where an item is accepted for which the original purchase document can not be determined, the price will be based on the list price that was effective twelve months prior to the RMA date.
11. Credit issued will be applied to future purchases only.

**PRICING AND REBATES**

Prices are subject to change without prior notice. Price changes are effective on a specific date and all orders received on or after that date will be billed at the revised price. Rebates for price declines and added charges for price increases will not be made for stock on hand at the time of any price change.

Multiquip reserves the right to quote and sell direct to Government agencies, and to Original Equipment Manufacturer accounts who use our products as integral parts of their own products.

**SPECIAL EXPEDITING SERVICE**

A \$20.00 to \$50.00 surcharge will be added to the invoice for special handling including bus shipments, insured parcel post or in cases where Multiquip must personally deliver the parts to the carrier.

**LIMITATIONS OF SELLER'S LIABILITY**

Multiquip shall not be liable here under for damages in excess of the purchase price of the item with respect to which damages are claimed, and in no event shall Multiquip be liable for loss of profit or good will or for any other special, consequential or incidental damages.

**LIMITATION OF WARRANTIES**

No warranties, express or implied, are made in connection with the sale of parts or trade accessories nor as to any engine not manufactured by Multiquip. Such warranties made in connection with the sale of new, complete units are made exclusively by a statement of warranty packaged with such units, and Multiquip neither assumes nor authorizes any person to assume for it any other obligation or liability whatever in connection with the sale of its products. A part from such written statement of warranty, there are no warranties, express, implied or statutory, which extend beyond the description of the products on the face hereof.



# PARTS AND OPERATION MANUAL

## **HERE'S HOW TO GET HELP**

*PLEASE HAVE THE MODEL AND SERIAL NUMBER  
ON-HAND WHEN CALLING*

### **PARTS DEPARTMENT**

*800-427-1244 or 310-537-3700*

*FAX: 800-672-7877 or 310-637-3284*

### **SERVICE DEPARTMENT/TECHNICAL ASSISTANCE**

*800-478-1244 or 310-537-3700*

*FAX: 310- 537-4259*

### **WARRANTY DEPARTMENT**

*888-661-4279, or 310-661-4279*

*FAX: 310- 537-1173*

### **MAIN**

*800-421-1244 or 310-537-3700*

*FAX: 310-537-3927*

**STOW**  
A DIVISION OF MULTIQUIP INC.

#### **STOW CONSTRUCTION EQUIPMENT**

*A DIVISION OF MULTIQUIP INC.*

*POST OFFICE BOX 6254*

*CARSON, CA 90749*

*310-537-3700 • 888-252-STOW [888-252-7869]*

*FAX: 310-537-1986 • FAX: 800-556-1986*

*E-MAIL: stow@multiquip.com • WWW: stowmfg.com*

#### **PARTS DEPARTMENT:**

*800-427-1244*

*FAX: 800-672-7877*

#### **SERVICE DEPARTMENT/TECHNICAL ASSISTANCE:**

*800-478-1244*

*FAX: 310-631-5032*