



UPA-88/UPA-88A Kit, Urethane Plate Attachment Installation Instructions

The following instructions are intended to assist the user in installing the UPA-88/UPA-88A Kit, Urethane Plate Attachment to the Multiquip MVC-88 Series plate compactors. The UPA-88/UPA-88A is designed for compacting paving stones and decorative brick. The pad prevents damage to the stone as the plate passes over the surface. It is not intended for soil or backfill compaction. Please read the instructions before assembling.

Item	Part Number	Description	Qty.	Remarks
A	UPA-88	Kit, Urethane Plate Attachment (contains items 1-9)	1	for casing height = 7/16" (MVC88 w/ S/N K6886 and below)
	UPA-88A	Kit, Urethane Plate Attachment (contains items 1A-9)	1	for casing height = 9/16" (MVC88 w/ S/N K6887 and above)
1	416456210	Interlocking Bolt 16x35, UP-88	2	for casing height = 7/16" (MVC88 w/ S/N K6886 and below)
1A	416456211	Interlocking Bolt 16x40, UP-88A	2	for casing height = 9/16" (MVC88 w/ S/N K6887 and above)
2	416342380	Hanger Block Plate	1	
3	012012030	Bolt 12x30	2	
4	030212300	Spring Washer M12	2	
5	416342370	Plate	1	
6	011208035	Bolt 8x35	4	
7	022710809	Nylon Nut M8	4	
8	PADUPA88	Urethane Pad	1	
9	416010030	Cap	2	

Refer to Figure 1 for location of parts and components when performing the following steps. Refer to Table for parts to be used.

- Using a 3/8" ratchet and 24 mm socket, remove and discard the 2 eccentric mounting bolts on the front of the MVC-88 plate compactor. Keep the 2 lock washers and the 2 flat washers from the mounting bolts.
- Using a 3/8" ratchet and 24 mm socket, screw the 2 interlocking bolts (item 1/1A) in place of the discarded mounting bolts with the old lock washers and flat washers. Use Loctite #271 (red) on the male thread portion only. Torque the screws to 203 ft-lb.
- Align the 4 holes of the plate (item 5) to the 4 holes on the front of the urethane pad (item 8). Using a 3/8" ratchet and 13 mm socket, install the four 8x35 bolts (item 6) to the 4 holes.
- On the other side of the urethane pad, attach the hanger block plate (item 2) by inserting the 4 holes to the bolts sticking out from the urethane pad.
- Fasten the hanger block plate in place using the 4 nylon nuts (item 7).
- Lay the assembled urethane pad flat on the ground and place the MVC-88 plate compactor on top of the pad with the hanger block plate about 2 to 3 inches from the front of the compactor's base plate.
- Slide in the assembled urethane pad towards the compactor aligning the 2 holes of the hanger block plate to the 2 interlocking bolts that were attached in step 2.
- Using a 3/8" ratchet and 19 mm socket, install the two 12x30 bolts (item 3) and 2 spring washers (item 4) to the 2 holes on the hanger block plate. Torque the screws to 86.8 ft-lb. **DO NOT USE LOCTITE OR OVERTIGHTEN.**

NOTE: When the urethane pad is removed for standard operation of the MVC-88 plate compactor, it is not necessary to remove the interlocking bolts (item 1). Place caps (item 9) over the bolts to keep the bolt threads clean while the urethane pad is not installed.

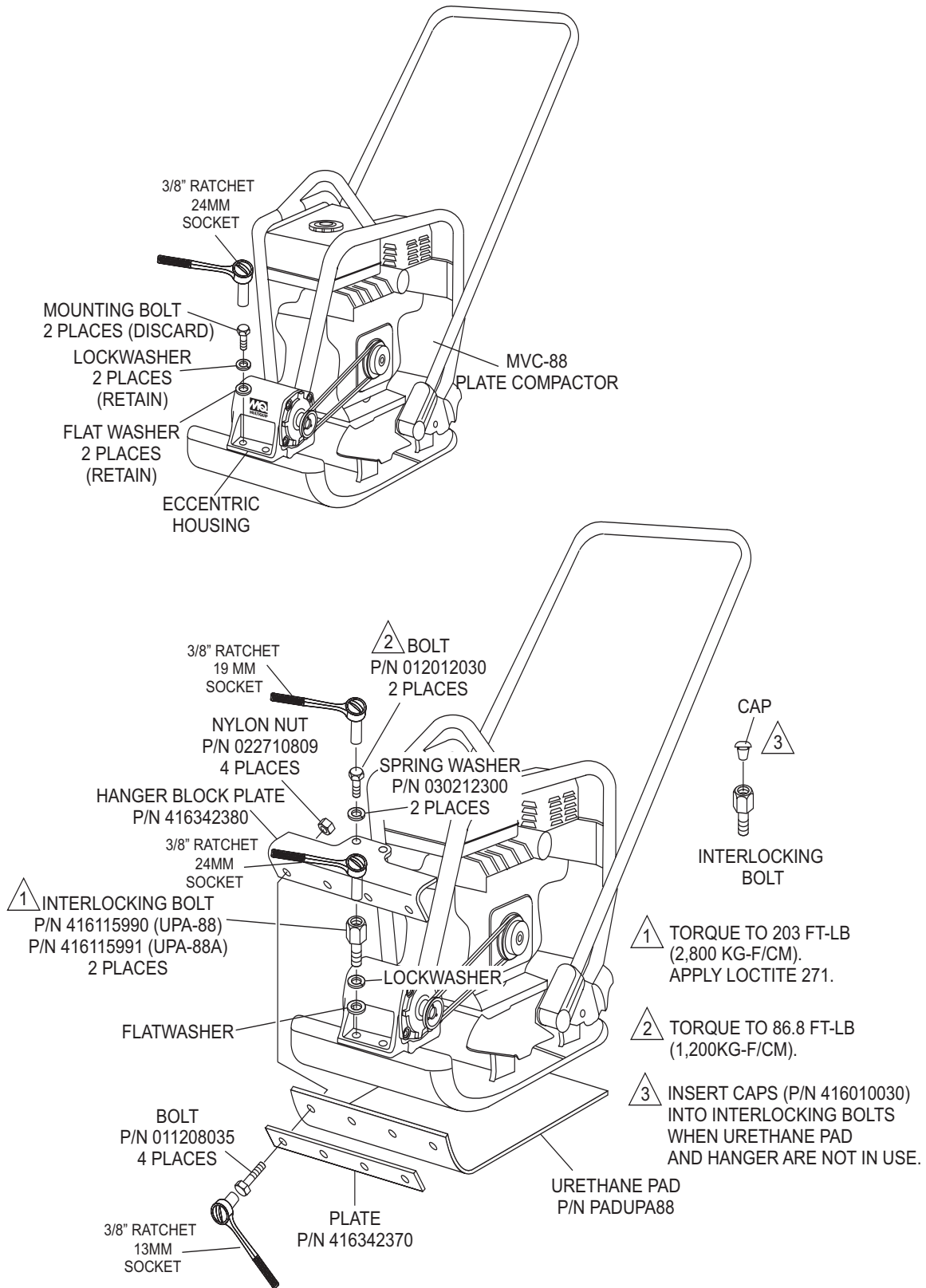

Figure 1. Location of Parts and Components