

OPERATION & PARTS MANUAL



Mikasa SERIES
MODEL MVH-R60H
REVERSABLE PLATE COMPACTOR
(HONDA GASOLINE ENGINE)

Revision #1 (09/09/04)

**THIS MANUAL MUST ACCOMPANY
THE EQUIPMENT AT ALL TIMES.**



WARNING



CALIFORNIA — Proposition 65 Warning

Engine exhaust and some of its constituents are known to the State of California to cause cancer, birth defects and other reproductive harm.

HERE'S HOW TO GET HELP

PLEASE HAVE THE MODEL AND SERIAL
NUMBER *ON-HAND* WHEN CALLING

MULTIQUIP CORPORATE OFFICE

18910 Wilmington Ave.

Carson, CA 90746

Email: mq@multiquip.com

Internet: www.multiquip.com

800-421-1244

FAX: 310-537-3927

PARTS DEPARTMENT

800-427-1244

310-537-3700

FAX: 800-672-7877

FAX: 310-637-3284

MAYCO PARTS

800-306-2926

310-537-3700

FAX: 800-672-7877

FAX: 310-637-3284

SERVICE DEPARTMENT

800-478-1244

310-537-3700

FAX: 310-537-4259

TECHNICAL ASSISTANCE

800-421-1244

FAX: 310-631-5032

WARRANTY DEPARTMENT

800-421-1244, EXT. 279

310-537-3700, EXT. 279

FAX: 310-537-1173

© COPYRIGHT 2004, MULTIQUIP INC.

Multiquip Inc and the MQ logo are registered trademarks of Multiquip Inc. and may not be used, reproduced, or altered without written permission. All other trademarks are the property of their respective owners and used with permission.

This manual MUST accompany the equipment at all times. This manual is considered a permanent part of the equipment and should remain with the unit if resold.

The information and specifications included in this publication were in effect at the time of approval for printing. Illustrations are based on the *Mikasa MVH-R60H Plate Compactor*. Illustrations, descriptions, references and technical data contained in this manual are for guidance only and may not be considered as binding. Multiquip Inc. reserves the right to discontinue or change specifications, design or the information published in this publication at any time without notice and without incurring any obligations.

To find the latest revision of this
publication, visit our website at:
www.multiquip.com



MULTIQUIP MVH-R60H PLATE COMPACTOR

Here's How To Get Help	3
Table Of Contents	4
Parts Ordering Procedures	5
Specifications	6
Dimensions	7
Safety Message Alert Symbols	8-9
Rules For Safe Operation.....	10-11
Operation and Safety Decals	12
General Information	13
Components (Plate Compactor)	14
Components (Honda Engine)	15
Inspection	16-17
Initial Start-Up	18-19
Operation	20
Maintenance	21-22
Preparation For Long Term Storage	23
Troubleshooting (Engine).....	24-25
Troubleshooting (Plate Compactor)	26
Explanation Of Codes In Remarks Column	28
Suggested Spare Parts	29

HONDA GX120K1SM12 GASOLINE ENGINE

Cylinder Head Assembly	46-47
Cylinder Barrel Assembly	48-49
Crankcase Cover Assembly	50-51
Crankshaft Assembly	52-53
Piston/Connecting Rod Assembly	54-55
Camshaft Assembly	56-57
Recoil Starter Assembly.....	58-59
Fan Cover Assembly	60-61
Carburetor Assembly	62-63
Air Cleaner Assembly.....	64-65
Muffler Assembly	66-67
Fuel Tank Assembly	68-69
Flywheel Assembly	70-71
Ignition Coil Assembly	72-73
Control Assembly	74-75
Label Assembly	76-77
Terms and Conditions Of Sale — Parts	78

COMPONENT DRAWINGS

Decal Placement	30-31
Control Assembly	32-35
Vibrator Assembly	36-37
Body Assembly	38-41
Vibrating Plate Assembly	42-43
Water Tank/Sprinkler Assembly.....	44-45

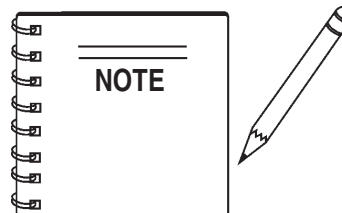

Specification and part number are subject to change without notice.

PARTS ORDERING PROCEDURES

When ordering parts, please supply the following information:

- Dealer account number
- Dealer name and address
- Shipping address (if different than billing address)
- Return fax number
- Applicable model number
- Quantity, part number and description of each part
- Specify preferred method of shipment:
 - ✓ FedEx or UPS Ground
 - ✓ FedEx or UPS Second Day or Third Day
 - ✓ FedEx or UPS Next Day
 - ✓ Federal Express Priority One
 - ✓ DHL
 - ✓ Truck

Note: Unless otherwise indicated by customer, all orders are treated as "Standard Orders", and will ship within 24 hours. We will make every effort to ship "Air Shipments" the same day that the order is received, if prior to 2PM west coast time. "Stock Orders" must be so noted on fax or web forms.



Here's how to get help...

Please have the model and serial number on hand when calling.

MULTIQUIP CORPORATE OFFICE

18910 Wilmington Ave. 800-421-1244
 Carson, CA 90746 FAX: 310-537-3927
 Email: mq@multiquip.com
 Internet: www.multiquip.com

PARTS DEPARTMENT

800-427-1244 FAX: 800-672-7877
 310-537-3700 FAX: 310-637-3284

MAYCO PARTS

800-306-2926 FAX: 800-672-7877
 310-537-3700 FAX: 310-637-3284

SERVICE DEPARTMENT

800-421-1244 FAX: 310-537-4259
 310-537-3700

TECHNICAL ASSISTANCE

800-478-1244 FAX: 310-631-5032

WARRANTY DEPARTMENT

800-421-1244, EXT. 279 FAX: 310-537-1173
 310-537-3700, EXT. 279

Place Your Parts Order Via Web or Fax For Even More Savings!

(Domestic USA Dealers Only)

Extra Discounts!

All parts orders which include complete part numbers and are received by our automated web parts order system, or by fax qualify for the following extra discounts:

Ordered via	Standard orders	Stock orders (\$750 list and above)
Fax	3%	10%
Web	5%	10%

Special freight allowances when you order 10 or more line items via Web or Fax! **

FedEx Ground Service **at no charge for freight**

No other allowances on freight shipped by any other carrier.

****Common nuts, bolts and washers (all items under \$1.00 list price) do not count towards the 10+ line items.**

NOTE: DISCOUNTS ARE SUBJECT TO CHANGE



MULTIQUIP INC.
 18910 WILMINGTON AVENUE
 POST OFFICE BOX 6254
 CARSON, CALIFORNIA 90749
 310-537-3700 • 800-421-1244
 FAX: 310-537-3927
 E-MAIL: mq@multiquip.com
 INTERNET: www.multiquip.com

Direct TOLL-FREE access to our Parts Department:

Toll-free nationwide — 800-427-1244

Toll-free FAX — 800-6-PARTS-7 (800/672-7877)

MVH-R60H — SPECIFICATIONS

TABLE 1. MVH-R60H REVERSIBLE PLATE COMPACTOR SPECIFICATIONS

Model	MVH-R60H
Centrifugal Force	3,100 lbs. (1,400 kg.)
Number of Vibrations	6,000 v/min.
Traveling Speed	82 ft./min (25 meters/min.)
Lubricating Oil in Vibration Case	17.92 fl. oz. (530 cc.)
Plate Size (LxW)	18.9 x 13.8 in. (480 x 350 mm.)
Operating Weight	141 lbs. (64 kg.)

TABLE 2. SPECIFICATIONS (ENGINE)

Engine	Model	Honda GX120K1SM12
	Type	Air-cooled 4 stroke, Single Cylinder, OHV, Horizontal Shaft Gasoline Engine
	Bore X Stroke	2.4 in. x 1.7 in. (60 mm x 42 mm)
	Displacement	119 cc (7.2 cu-in)
	Max Output	4.0 H.P./3600 R.P.M.
	Fuel Tank Capacity	0.66 US gal. (2.5 liters)
	Fuel	Unleaded Automobile Gasoline
	Lube Oil Capacity	.60 liters (0.63 qts)
	Speed Control Method	Centrifugal Fly-weight Type
	Starting Method	Recoil Start
Dimension - (L x W x H)		11.7 x 13.4 x 12.5 in. (297 x 341 x 318 mm)
Dry Net Weight		28.7 lbs (13 Kg.)

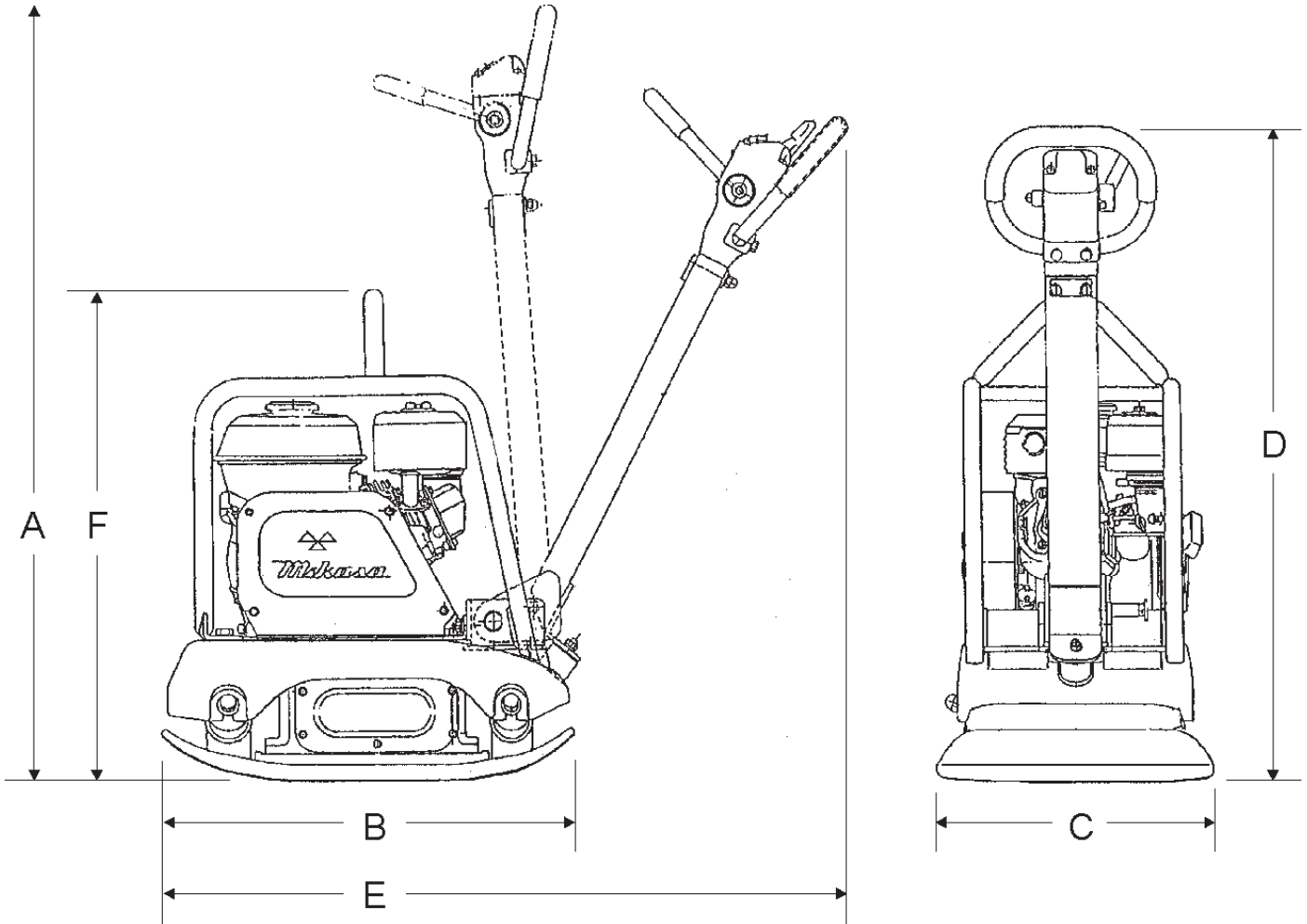

Figure 1. MVH-R60H Dimensions

TABLE 3. DIMENSIONS

REF.	DIMENSIONS
A	45 in. (134.6 cm.)
B	22 in. (61 cm.)
C	13 in. (86 cm.)
D	41 in. (162 cm.)
E	35 in. (97 cm.)
F	25 in. (97 cm.)
Shipping Dimensions:	14.5 x 23 x 43 in. (36.8 x 58.4 x 109 cm.)

MVH-R60H — SAFETY MESSAGE ALERT SYMBOLS

FOR YOUR SAFETY AND THE SAFETY OF OTHERS!

Safety precautions should be followed at all times when operating this equipment. Failure to read and understand the Safety Messages and Operating Instructions could result in injury to yourself and others.

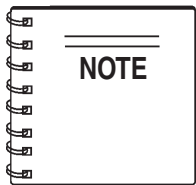

This Owner's Manual has been developed to provide complete instructions for the safe and efficient operation of the Multiquip MVC-R60H Plate Compactor. Refer to the engine

manufacturer's instructions for data relative to its safe operation.

Before using this plate compactor, ensure that the operating individual has read and understands all instructions in this manual.

SAFETY MESSAGE ALERT SYMBOLS

The three (3) Safety Messages shown below will inform you about potential hazards that could injure you or others. The Safety Messages specifically address the level of exposure to the operator, and are preceded by one of three words: **DANGER**, **WARNING**, or **CAUTION**.

DANGER

You **WILL** be **KILLED** or **SERIOUSLY** injured if you **DO NOT** follow directions.

WARNING

You **CAN** be **KILLED** or **SERIOUSLY** injured if you **DO NOT** follow directions.

CAUTION

You **CAN** be **INJURED** if you **DO NOT** follow directions.

Potential hazards associated with the operation of an **MVH-R60H Plate Compactor** will be referenced with Hazard Symbols which appear throughout this manual, and will be referenced in conjunction with Safety Message Alert Symbols.

HAZARD SYMBOLS

WARNING - Lethal Exhaust Gasses

Engine exhaust gases contain poisonous carbon monoxide. This gas is colorless and odorless, and can cause death if inhaled. **NEVER** operate this equipment in a confined area or enclosed structure that does not provide ample free flow air.



WARNING - Explosive Fuel

Gasoline is extremely flammable, and its vapors can cause an explosion if ignited. **DO NOT** start the engine near spilled fuel or combustible fluids.



DO NOT fill the fuel tank while the engine is running or hot. **DO NOT** overfill tank, since spilled fuel could ignite if it comes into contact with hot engine parts or sparks from the ignition system. Store fuel in approved containers, in well-ventilated areas and away from sparks and flames.

WARNING - Burn Hazards

Engine components can generate extreme heat. To prevent burns, **DO NOT** touch these areas while the engine is running or immediately after operations. Never operate the engine with heat shields or heat guards removed.



CAUTION - Respiratory Hazard

ALWAYS wear approved **respiratory** protection when required.



MVH-R60H — SAFETY MESSAGE ALERT SYMBOLS

CAUTION - Rotating Parts

NEVER operate equipment with covers, or guards removed. Keep fingers, hands, hair and clothing away from all moving parts to prevent injury.



CAUTION - Equipment Damage Messages

Other important messages are provided throughout this manual to help prevent damage to your light tower, other property, or the surrounding environment.

CAUTION - Accidental Starting

ALWAYS place the power source, circuit breakers or **ON/OFF** switch in the **OFF** position, when the generator is not in use, unless connected to transfer switch.

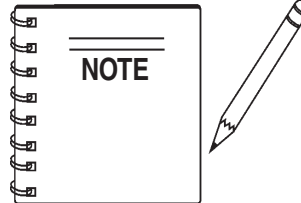

This reversible plate compactor, other property, or the surrounding environment could be damaged if you do not follow instructions.

CAUTION - Sight and Hearing Hazards

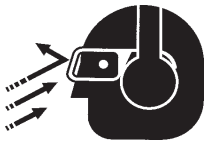

ALWAYS wear approved eye and hearing protection.

MVH-R60H — RULES FOR SAFE OPERATION

WARNING - Read This Manual

Failure to follow instructions in this manual may lead to **Serious Injury** or even **Death**. This equipment is to be operated by trained and qualified personnel only! This equipment is for industrial use only.

The following safety guidelines should always be used when operating the Mikasa MVH-R60H Reversible Plate Compactor:

Safety:

- **DO NOT** operate or service this equipment before reading this entire manual.
- This equipment should not be operated by persons under 18 years of age.
- **NEVER** operate this equipment without proper protective clothing, shatterproof glasses, steel-toed boots and other protective devices required by the job.



- **NEVER** operate this equipment when not feeling well due to fatigue, illness or taking medicine.
- **NEVER** operate this equipment under the influence of **drugs** or **alcohol**.



- **NEVER** use accessories or attachments, which are not recommended by Multiquip for this equipment. Damage to the equipment and/or injury to user may result.
- Manufacturer does not assume responsibility for any accident due to equipment modifications. Unauthorized equipment modification will void all warranties.
- Whenever necessary, replace nameplate, operation and safety decals when they become difficult read.
- **ALWAYS** check all the bolts on the light tower for tightness.
- **NEVER** disconnect any "**emergency or safety devices**". These devices are intended for operator safety. Disconnection of these devices can cause severe injury, bodily harm or even death! Disconnection of any of these devices will void all warranties.

- **NEVER** touch the hot exhaust manifold, muffler or cylinder. Allow these parts to cool before servicing engine or generator.

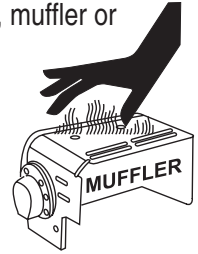

- **High Temperatures** – Allow the engine to cool before adding fuel or performing service and maintenance functions. Contact with *hot* components can cause serious burns.

- The engine of this reversible plate compactor requires an adequate free flow of cooling air. **NEVER** operate the reversible plate compactor in any enclosed or narrow area where free flow of the air is restricted. If the air flow is restricted it will cause serious damage to the reversible plate compactor or engine and may cause injury to people and property. Remember the vibration roller's engine gives off **DEADLY** gases.

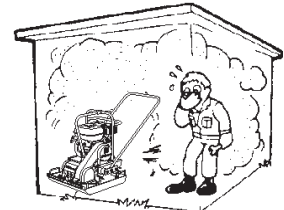

- **ALWAYS** refuel in a well-ventilated area, away from sparks and open flames.

- **ALWAYS** use extreme caution when working with **flammable** liquids. When refueling, **stop the engine** and allow it to cool. **DO NOT smoke** around or near the machine. Fire or explosion could result from fuel vapors, or if fuel is spilled on a hot engine.



- **NEVER** operate the reversible plate compactor in an explosive atmosphere or near combustible materials. An explosion or fire could result causing severe *bodily harm or even death*.

- Topping-off to filler port is dangerous, as it tends to spill fuel.
- **ALWAYS** store the reversible plate compactor in a clean, dry location out of the reach of children.
- **NEVER** run engine without air cleaner. Severe engine damage may occur.
- **NEVER** leave the reversible plate compactor unattended, turn off engine.
- **CAUTION** must always be observed while servicing this reversible plate compactor. Rotating parts can cause injury if contacted.
- **DO NOT** leave reversible plate compactor with engine running.

MVH-R60H — RULES FOR SAFE OPERATION

Loading and Unloading (Crane):

- Before lifting, make sure that machine parts (hook and vibration insulator) are not damaged and screws are not loosened or lost.
- Always make sure crane or lifting device has been properly secured to the hook of guard frame on compactor.
- **NEVER** lift the machine while the engine is running.
- Use adequate lifting cable (wire or rope) of sufficient strength.
- Use one point suspension hook and lift straight upwards.
- **NEVER** allow any person or animal to stand underneath the machine while lifting.
- Try not to lift machine to unnecessary heights.

Transporting:

- **ALWAYS** shutdown engine before transporting.
- Tighten fuel tank cap securely and close fuel cock to prevent fuel from spilling.
- Drain fuel when transporting compactor over long distances or bad roads.
- **ALWAYS** tie down the compactor during transportation by securing the compactor's guard frame with rope.

Maintenance Safety:

- **NEVER** lubricate components or attempt service on a running machine.
- **ALWAYS** allow the machine a proper amount of time to cool before servicing.
- Keep the machinery in proper running condition.
- Fix damage to the machine immediately and always replace broken parts.
- Dispose of hazardous waste properly. Examples of potentially hazardous waste are used motor oil, fuel and fuel filters.
- **DO NOT** use food or plastic containers to dispose of hazardous waste.
- **DO NOT** pour waste, oil or fuel directly onto the ground, down a drain or into any water source.

Emergencies:

- **ALWAYS** know the location of the nearest **fire extinguisher**.
- **ALWAYS** know the location of the nearest **first aid kit**.
- In emergencies **always** know the location of the nearest phone or **keep a phone on the job site**. Also know the phone numbers of the nearest **ambulance, doctor** and **fire department**. This information will be invaluable in the case of an emergency.



MVH-R60H — OPERATION AND SAFETY DECALS

Machine Safety Decals

The MVH-R60H Reversible Plate Compactor is equipped with a number of safety decals. These decals are provided for operator safety and maintenance information. The illustration below shows these decals as they appear on the machine. Should any of these decals become unreadable, replacements can be obtained from your dealer.



P/N: TBD



P/N: 920207480



**CONTACT
SERVICE DEPT.**

MVH-R60

P/N: TBD



P/N: 920207420

DANGER FUEL	DANGER FUEL	DANGER LIFTING	DANGER LIFTING
Fire Risk	Operate only in well-ventilated area	Do not stand next to machine while lifting	Do not use machine handle
WARNING NOISE	WARNING HOT TEMP.	CAUTION MOVING PARTS	CAUTION READ
Wear eye protection	Operate only in well-ventilated area	Do not touch moving parts in operation	Read operator's manual carefully before use

OPERATIONAL CAUTION

- Prior to OPERATION, check engine oil and fuel levels. If not enough, add to proper levels.
- Warm up engine at low speed for 3 to 5 minutes.
- Operate machine at full throttle speed. (Incorrect clutch engagement causes clutch to burn.)
- Use travel lever to travel in reverse motion. Do not push or pull travel lever strongly.

NPA-952 J

P/N: 920209520

Figure 2. Operation and Safety Decals

Definition of Plate Compactor

The Mikasa MVH-R60H is a walk-behind, reversible plate compactor design for the compaction of sand, clay and asphalt. This plate compactor is a powerful compacting tool capable of applying a tremendous force in consecutive high frequency vibrations to a soil surface. Its applications include soil compacting for road, embankments and reservoirs as well as backfilling for gas pipelines, water pipelines and cable installation work.

Vibratory Plates

The vibratory plates of the MVH-R60H produce low amplitude high frequency vibrations, designed to compact granular soils.

The resulting vibrations cause forward motion. The engine and handle are vibration isolated from the vibrating plate. The heavier the plate, the more compaction force it generates.

Reversible Vibratory Plates

Reversible vibratory plates have two eccentric weights that allow a smooth transition for forward and reverse travel, plus increased compaction force as the result of dual weights.

Due to their weight and force, reversible plates are ideal for semi-cohesive soils.

Frequency/Speed

The compactor's vibrating plate has a frequency of 6000 vpm (vibrations per minute). The forward and reverse travel speed of the compactor is approximately 82 ft./minute (25 meters/minute).

Engine

The Mikasa MVH-R60H Reversible Plate Compactor is equipped with an Honda GX120K1SM12 gasoline engine.

Controls

Before starting the MVH-R60H Reversible Plate Compactor, identify and understand the function of the controls and components as indicated on Figure 3.

MVH-R60H — COMPONENTS (PLATE COMPACTOR)

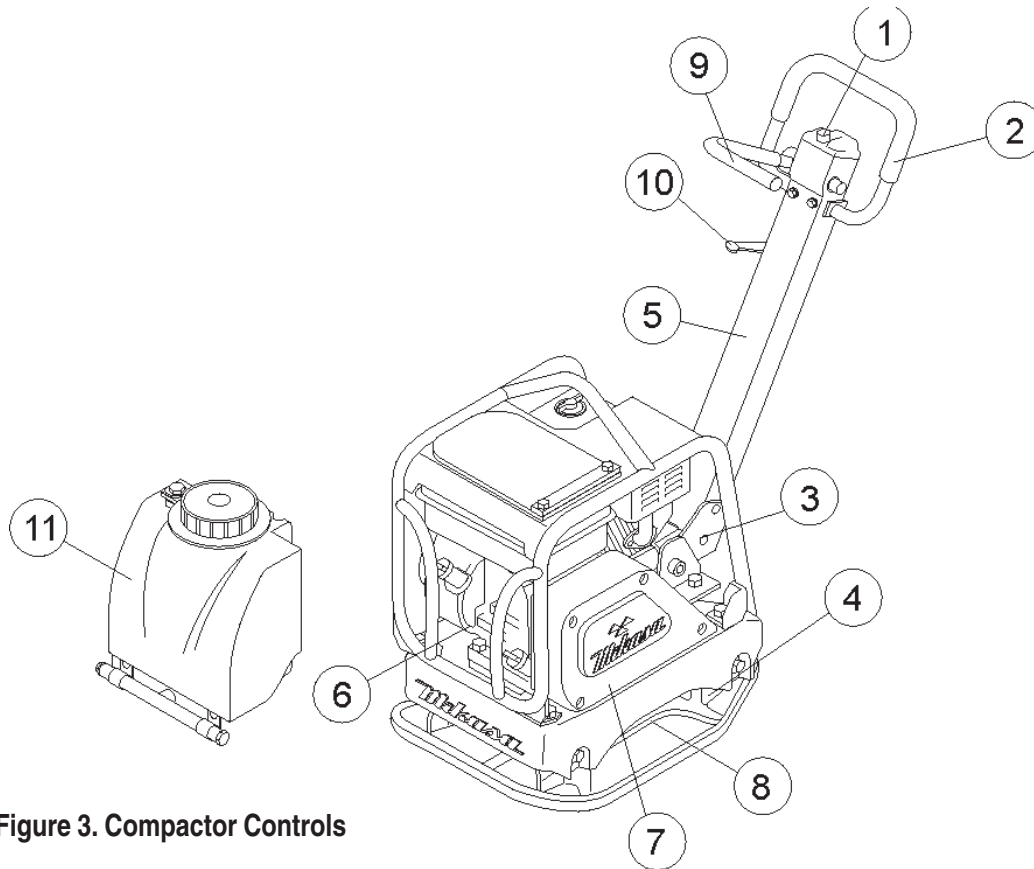

Figure 3. Compactor Controls

Figure 3 shows the location of the controls, indicators and general maintenance parts. The function of each control is described below:

1. **Breather Cap** – Remove this cap to bleed (remove air) the hydraulic system. When replacing hydraulic oil, use "Shell Tellus #46 or equivalent".
2. **Hand Grip** – When operating the compactor use this hand grip to maneuver the compactor.
3. **Handle Lock** – Pull handle bar downward (working position), then pull handle lock to lock handle bar in place.
4. **Vibration Case Oil Level Check Plug** – Remove this plug to check the vibration case oil. Oil level should be all the way up to the filler port. When replacing vibration case oil, use 10W-30 engine oil.
5. **Handle Bar (working position)** – When operating the compactor, this handle is to be in the downward position.
6. **Gasoline Engine** – This plate compactor uses a Honda GX120K1SM12 engine. Refer to the engine owners manual for engine information and related topics.
11. **Water Tank** – Optional water tank used for dust control and as a compaction aid. Attaches to the front of the R60's frame.

7. **Belt Cover** – Remove this cover to gain access to the V-belts.

CAUTION - V-belt Safety

NEVER attempt to check the V-belt with the engine running or operate the machine with the cover removed. Severe injury can occur if your hand gets caught between the V-belt and the clutch. Always use safety gloves.



8. **Vibration Case** – Encloses the eccentric, gears and counter weights.
9. **Forward & Reverse Lever** – **Push** the lever forward, the compactor will move in a forward direction, **pull** the lever backwards, the compactor will move in backwards direction. Placing the lever in the middle (midway) will cause the compactor not to move (neutral).
10. **Throttle Control** – Move the throttle lever to the **rabbit** position for full throttle (max RPM's), for engine idle, move the throttle lever to the **turtle** position.

MVH-R60H — COMPONENTS (HONDA GX120K1SM12 ENGINE)

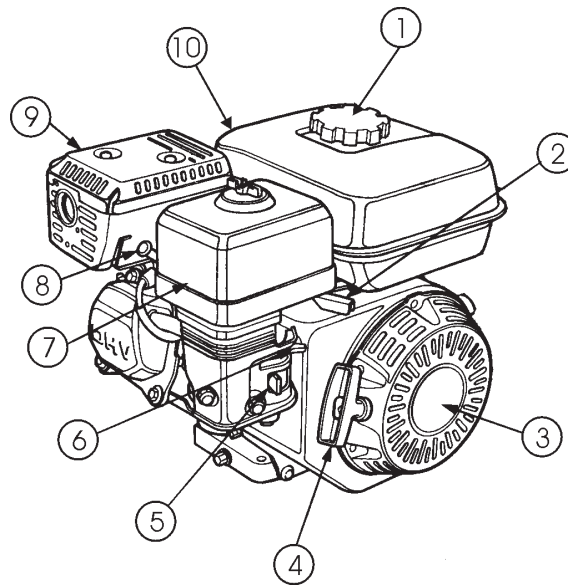

Figure 4. Honda GX160K1QA2 Engine Controls & Components

INITIAL SERVICING

The engine (Figure 4) must be checked for proper lubrication and filled with fuel prior to operation. Refer to the manufacturer's Engine manual for instructions & details of operation and servicing.

1. **Fuel Filler Cap** – Remove this cap to add unleaded gasoline to the fuel tank. Make sure cap is tightened securely. **DO NOT** over fill.

CAUTION - Fueling The Engine

Adding fuel to the tank should be done only when the engine is stopped and has had an opportunity to cool down. In the event of a fuel spill, **DO NOT** attempt to start the engine until the fuel residue has been completely wiped up, and the area surrounding the engine is dry.



2. **Throttle Lever** – Used to adjust engine RPM speed (lever advanced forward **SLOW**, lever back toward operator **FAST**).
3. **Engine ON/OFF Switch** – **ON** position permits engine starting, **OFF** position stops engine operations.
4. **Recoil Starter (pull rope)** – Manual-starting method. Pull the starter grip until resistance is felt, then pull briskly and smoothly.
5. **Fuel Valve Lever** – **OPEN** to let fuel flow, **CLOSE** to stop the flow of fuel.

6. **Choke Lever** – Used in the starting of a cold engine, or in cold weather conditions. The choke enriches the fuel mixture.
7. **Air Cleaner** – Prevents dirt and other debris from entering the fuel system. Remove wing-nut on top of air filter canister to gain access to filter element.

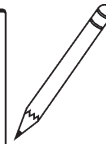
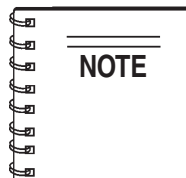

Operating the engine without an air filter, with a damaged air filter, or a filter in need of replacement will allow dirt to enter the engine, causing rapid engine wear.

8. **Spark Plug** – Provides spark to the ignition system. Set spark plug gap to 0.6 - 0.7 mm (0.028 - 0.031 inch) for Honda engine. Clean spark plugs once a week.
9. **Muffler** – Used to reduce noise and emissions.

CAUTION - Burn Hazard

Engine components can generate extreme heat. To prevent burns, **DO NOT** touch these areas while the engine is running or immediately after operating. **NEVER** operate the engine with the muffler removed.



10. **Fuel Tank** – Holds unleaded gasoline. For additional information refer to engine owner's manual.

CAUTION - General Safety Precautions

NEVER operate the compactor in a confined area or enclosed area structure that does not provide ample **free flow of air**.



ALWAYS wear approved eye and hearing protection before operating the compactor.

Before Starting:

1. Read safety instructions at the beginning of manual.
2. Remove dirt and dust, particularly in the engine cooling air inlet, carburetor and air cleaner.
3. Check the air filter for dirt and dust. If air filter is dirty, clean the air filter using compressed air, or replace the air filter with a new one as necessary.
4. Check carburetor for external dirt and dust. Clean with dry compressed air.
5. Check fastening nuts and bolts for tightness.



Engine Oil Check

1. To check the engine oil level, place the plate compactor on secure level ground with the engine stopped.
2. Remove the filler cap/dipstick from the engine oil filler hole (Figure 5) and wipe it clean.

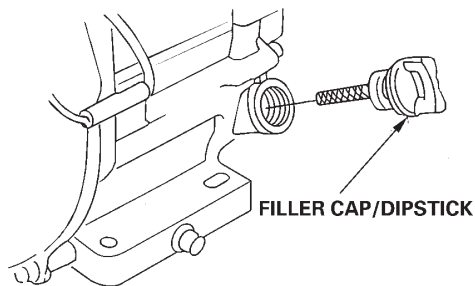

Figure 5. Engine Oil Dipstick

3. Insert and remove the dipstick without screwing it into the filler neck. Check the oil level shown on the dipstick.
4. If the oil level is low (Figure 6), fill to the edge of the oil filler hole with the recommended oil type (Table 4). Maximum oil capacity is 400 cc.

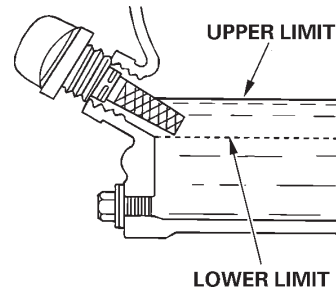
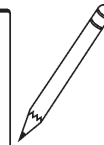
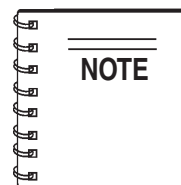

Figure 6. Engine Oil Dipstick



The Oil Alert system will automatically stop the engine before the engine falls below safe limits. Always be sure to check the engine oil level prior to starting the engine.

Table 4. Oil Type

Season	Temperature	Oil Type
Summer	(25°C or Higher)	SAE 10W-30
Spring/Fall	(25°C~10°C)	SAE 10W-30/20
Winter	Lower than 10°C	SAE 10W-10

Fuel Check

1. Remove the cap located on top of fuel tank.
2. Visually inspect to see if fuel level is low. If fuel is low, replenish with unleaded fuel.
3. When refueling, be sure to use a strainer for filtration. **DO NOT** top-off fuel. Wipe up any spilled fuel.

WARNING - Explosive Fuel

Gasoline is extremely flammable, and its vapors can cause an explosion if ignited. **DO NOT** start the engine near spilled fuel or combustible fluids. **DO NOT** smoke while refueling. **DO NOT** attempt to refuel the pump if the engine is **hot!** or **running**.



MVH-R60H — START-UP PROCEDURE

This section is intended to assist the operator with the **initial start-up** of the compactor. It is extremely important that this section be read carefully before attempting to use the compactor in the field.

1. Place the **fuel valve lever** (Figure 7) in the **ON** position.

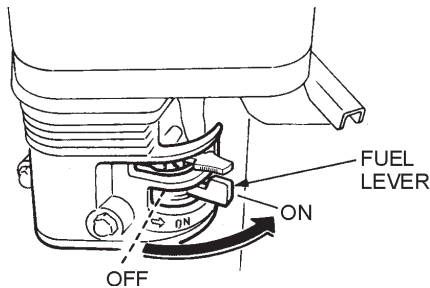

Figure 7. Fuel Valve Lever

2. Place the **Engine ON/OFF switch** (Figure 8) in the **ON** position.

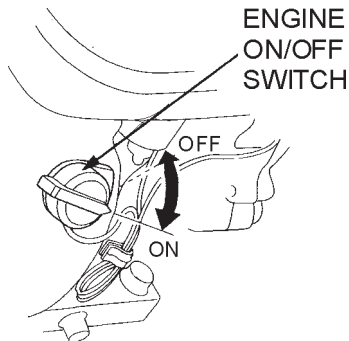

Figure 8. Engine ON/Off Switch

3. Place the **Choke Lever** (Figure 9) in the **OPEN** position.

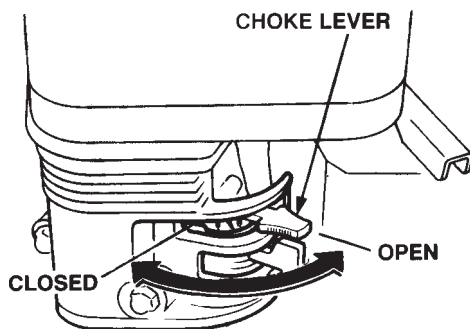
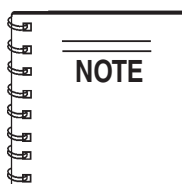

Figure 9. Choke Lever



The **CLOSED** position of the choke lever enriches the fuel mixture for starting a **COLD** engine. The **OPEN** position provides the correct fuel mixture for normal operation after starting, and for restarting a warm engine.

4. Place the **throttle lever** halfway between **FAST** and **SLOW**. This compactor is equipped with a throttle lever (Figure 10) that is located in the vicinity of the hydraulic pump. This throttle lever is connected to the engine throttle linkage.

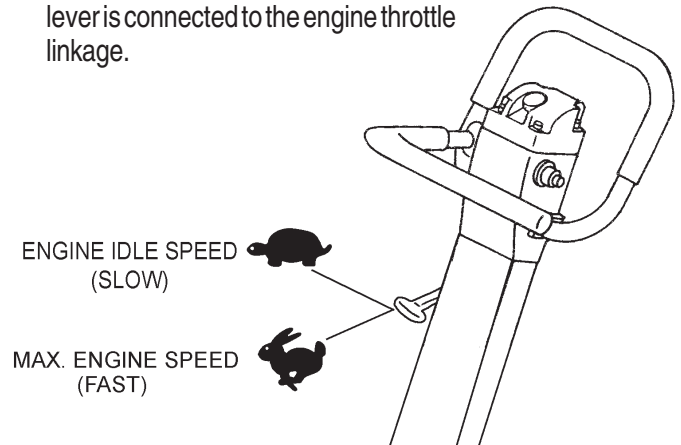

Figure 10. Engine Throttle Lever

5. Grasp the starter grip (Figure 11) and slowly pull it out. The resistance becomes the hardest at a certain position, corresponding the compression point. Rewind the rope a little from that point and pull out sharply.

! CAUTION - Using the Recoil Starter Rope

DO NOT pull the starter rope all the way to the end.

DO NOT release the starter rope after pulling. Allow it to rewind as soon as possible.

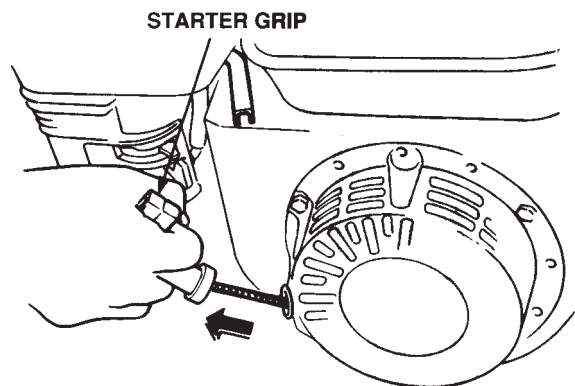

Figure 11. Starter Grip

6. If the engine has started, slowly return the choke lever (Figure 11) to the **CLOSED** position. If the engine has not started repeat steps 1 through 5.
7. Before the compactor is put into operation run the engine for 3-5 minutes.
8. Check for abnormal engine noises or fuel leaks.

MVH-R60H — SHUT-DOWN PROCEDURES

Stopping the Engine

! CAUTION - Stopping the engine while working

NEVER stop the engine suddenly while working at high speeds. This can damage your engine.

1. Place the **throttle lever** (Figure 12) in **SLOW** position, and listen for the engine speed to decrease.

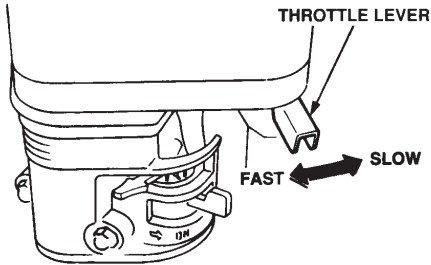

Figure 12. Throttle Lever (SLOW Position)

2. Place the **Engine ON/OFF switch** (Figure 13) in the **OFF** position.

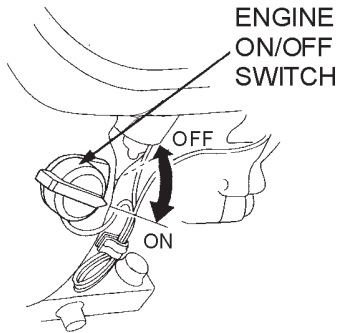

Figure 13. Engine ON/Off Switch (OFF Position)

3. Place the **fuel valve lever** (Figure 14) in the **OFF** position.

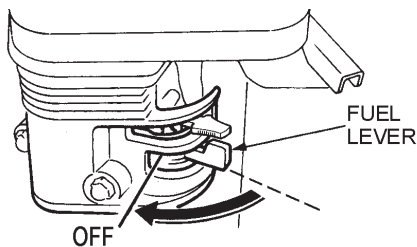

Figure 14. Fuel Valve Lever (OFF Position)

Emergency Shutdown Procedure:

1. Move the throttle lever quickly to the **SLOW** position (Figure 12).
2. Place the engine **ON/OFF** switch in the **OFF** position (Figure 13).

Operation

CAUTION - General Operation Safety

Make sure to follow all safety rules referenced in the safety section of this manual before operating compactor. Keep work area clear of debris and other objects that could cause damage to the compactor or bodily injury.

1. Grasp the compactor's hand grip and move the throttle lever (Figure 10) quickly to the **fast** position. The compactor will not operate correctly until the engine speed is high enough to engage the centrifugal clutch (approximately 2300 RPMs)

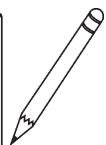
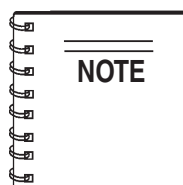

Always move the throttle lever quickly without hesitation, because increasing the engine speed slowly causes the clutch to slip.

2. To make the compactor move in the forward direction push the **Directional Travel Lever** (Figure 15) forward.

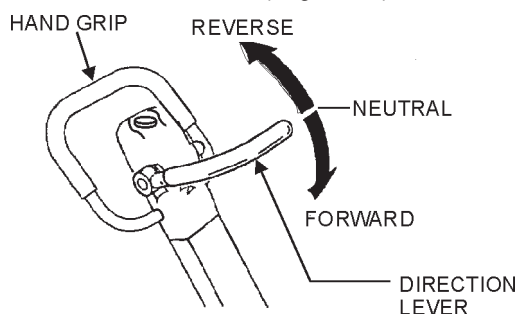

Figure 15. Directional Travel Lever

3. To make the compactor move in the reverse direction pull the **Directional Travel Lever** (Figure 15) backwards.
4. Firmly gasp the compactor's hand grip, the compactor will begin moving in the desired position when the **Directional Travel Lever** has been placed in the desired position.
5. Slowly walk behind the compactor and be on the lookout for any large objects or foreign matter that might cause damage to the compactor or bodily injury.

CAUTION - Directional Travel Lever Lock

Moving the **Directional Travel Lever** back and forth a few times after the engine has been turned off, will cause the lever to be locked in the forward position.

DO NOT try to operate lever forcibly. The direction travel lever will operate normally when the engine is started and the compactor is in action.

Operating the Compactor on High Moisture Content Soil

Compactor traveling speed may drop on soils which contain clay, or other types of soil. Soil with high moisture content can cause the compaction plate to "stick" to the ground (not lifting up off the ground very fast or high).

To rectify this problem, consider the following:

- Check the bottom plate to see if clay or equivalent material has been lodge in the plate mechanism. If so, wash with water and remove.
- Remember the compactor does not work as efficiently on clay or soils that have a high moisture content level.
- If the soil has a high moisture level, dry soil to appropriate moisture content level or carry out compaction twice.

Maintenance

⚠ CAUTION - General Maintenance Safety

Inspection and other services should **always** be carried out on hard and level ground with the engine shutdown.

Inspection and Maintenance Service Tables.

To make sure your plate compactor is always in good working condition before using, carry out the maintenance inspection in accordance with Tables 5 through 7.

Daily Service

- Check for leakage of fuel or oil.
- Check for loose screws including tightness. See Table 7 below (tightening torque), for retightening:
- Remove soil and clean the bottom of compaction plate.
- Check hydraulic pump, piping and hose for any leakage. A loosened hydraulic hose can be a cause for leakage. Check hydraulic hose connections with wrench applied for tightness.
- Check engine oil, see Inspection section.

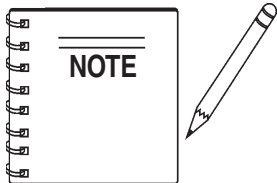

These inspection intervals are for operation under normal conditions. Adjust your inspection intervals based on the number hours plate compactor is in use, and particular working conditions.

Material	6mm	8mm	10mm	12mm	14mm	16mm	18mm	20mm
4T	70	150	300	500	750	1,100	1,400	2,000
6-8T	100	250	500	800	1,300	2,000	2,700	3,800
11T	150	400	800	1,200	2,000	2,900	4,200	5,600
*	100 (6mm)		300 ~ 350 (8mm)			650 ~ 700 (10mm)		
* (In case counter-part is of aluminum)								
Material and quality of material is marked on each bolt, and screw.								
Note: Threads in use with this machine are all right handed								

Item	Hours of Operation	Remarks
(Starting check)	Every 8 hours (every day)	
Loosened or lost screws	Every 8 hours (every day)	
Damage of any part	Every 8 hours (every day)	
Function of controlling system part	Every 8 hours (every day)	
Leak of hydraulic system	Every 100 hours	See page 21.
Vibrator oil check	Every 300 hours	See page 22.
Vibrator oil replacement	Every 100 hours	See page 22.
Hydraulic oil check	First 200 hours, then every 1000 hrs.	See page 23.
V-belt (clutch) check	Every 200 hours	See page 22.

Item	Hours of Operation
Leakage of oil or fuel	Every 8 hours (Check Daily)
Tightness of fastening threads	Every 8 hours (Check Daily)
Engine oil check and replenishment	Every 8 hours (Check Daily) (Replenish to specified max. level)
Engine oil replenishment	First 20 hours, then every 100 hours
Air cleaner cleaning	Every 50 hours

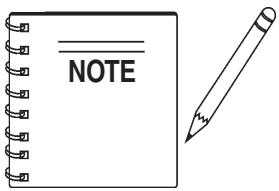

Fuel piping and connections should be replaced every 2 years.

Spark Plug

1. Remove and clean the spark plug (Figure 16).
2. Adjust the spark gap to 0.028 ~0.031 inch (0.6~0.7 mm). This unit has electronic ignition, which requires no adjustments.

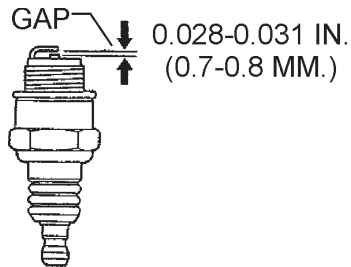

Figure 16. Spark Plug Gap

Engine Oil Replacement:

1. Replace engine oil after the first 20 hours of operation and every 100 hours thereafter.
2. Oil may be drained more easily when it is warm after operation.
3. When changing the engine oil, the old oil can be drained by removing the oil filler cap, and unscrewing the engine oil drain plug located at the base of the engine (Figure 17).
4. Remember to refill engine crankcase with the recommended type of oil as listed in Table 4 (For more details, see separate Honda Owner's Manual).

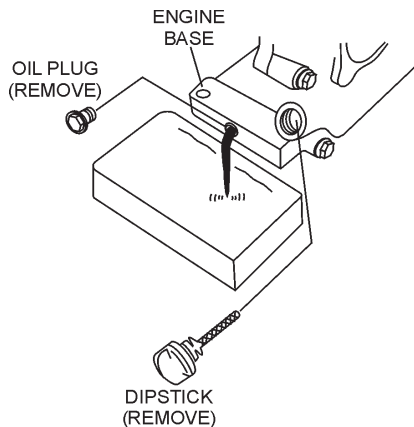

Figure 17. Engine Oil Plug

Air Filter

The air filter element should be regularly cleaned. A clogged air cleaner can cause poor engine starting, lack of power and shorten engine life substantially.

1. To clean or replace air filter loosen the wing nut on the air filter housing (Figure 18), remove the cover and take out air filter cartridge. If only cleaning of the air filter is desired blow through the air filter cartridge from the inside, moving a jet of dry compressed air up and down until all dust is removed.

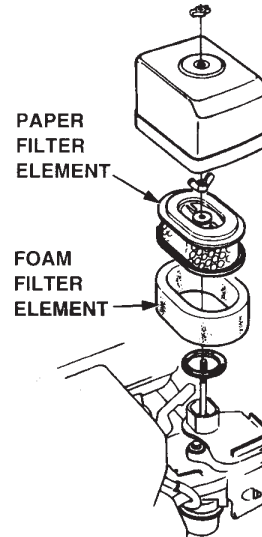

Figure 18. Air Filter

Checking and Replacing the V-Belt and Clutch

! CAUTION - Checking and Replacing the V-Belt

NEVER attempt to check the V-belt with the engine running. Severe injury can occur if your hand gets caught between the V-belt and the clutch. Always use safety gloves.



1. To check the V-belt tension (Figure 19), remove **upper** belt cover.

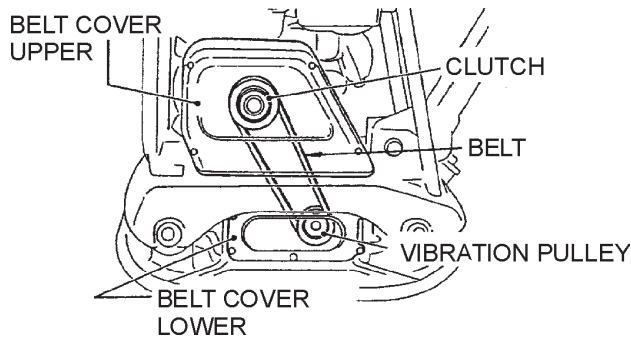

Figure 19. V-Belt Location

2. The V-belt tension is proper if the V-belt bends 10 to 15 mm (Figure 20) when depressed with finger at midway between the clutch and vibration pulley shafts.

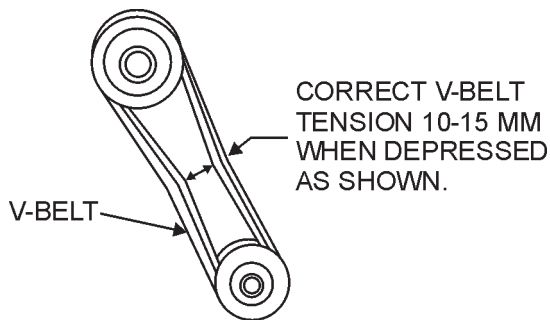

Figure 20. V-Belt Tension

3. If the V-belt becomes worn or loose, replace the belt. A loose V-belt will decrease the power transmission output, causing reduced compaction and premature wear of the belt.

Replacing the V-belt

1. Remove the belt cover.
2. Engage an offset wrench (13 mm) or the like to vibrator pulley (lower) fastening bolt.
3. Engage waste cloth or the like at midway of V-belt on the left side and while pulling it back strongly, rotate the offset wrench clockwise so that the V-belt will come off.
4. Check the clutch and replace as necessary, following the procedures listed in **Checking the Clutch**.
5. Engage V-belt to lower vibrator pulley and push the V-belt to the left side of the upper clutch and the rotate offset wrench clockwise so that the V-belt moves onto the pulley.

Checking the Clutch

1. With belt cover removed, visually check outer drum of the clutch for seizure and "V" groove for wear or damage.
2. Clean the "V" groove as necessary.
3. Check the clutch lining and shoe for signs of wear. If the shoe is worn, replace the clutch to prevent deficient power transmission and slippage.

Replacing the Clutch

1. Remove V-belt.
2. Remove bolt at engine power output by giving a shock to an engaged wrench (e.g. tapping with hammer) and rotate the bolt counterclockwise.
3. Remove clutch with a pulley extractor.
4. To install a new clutch, reverse steps 1-3.

Hydraulic Oil Check

Check hydraulic oil in every 100 hours of operation.

1. With handle bar positioned vertically (storage position), remove the breather cap (Figure 8) from the breather plug.
2. Use a 24 mm wrench and remove breather plug (Figure 21). Visually check to see if hydraulic oil comes up to the oil level line that is etched on the back side of the handle.

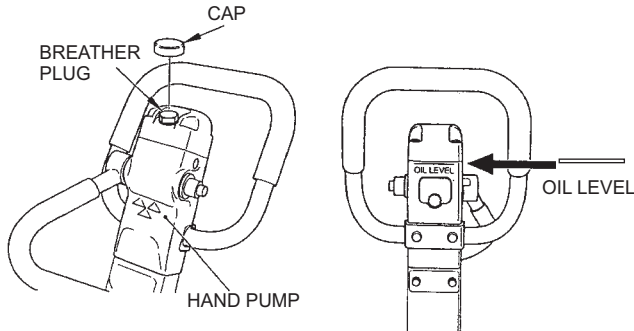

21. Vibrator Oil Gauge

2. If the hydraulic oil level is low, replace with "Shell Tellus" oil #46 or equivalent.

Replace hydraulic oil after first 200 hours and in every 1,000 hours of operation.

Replacing Hydraulic Oil

1. After removing plug cap of hand pump (Figure 22), remove plug of breather (24 mm wrench) and disconnect vibrator side of hydraulic hose (Figure 22) at vibrator cylinder. With travel lever placed in the **FORWARD** position, drain hydraulic oil in the pump.

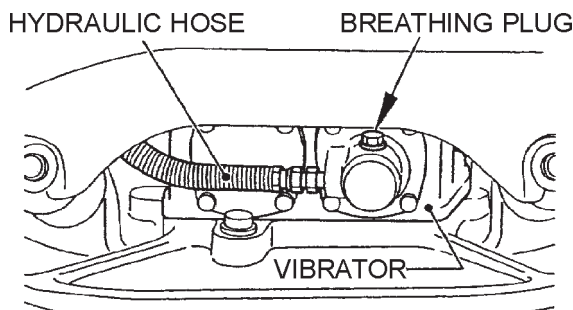

Figure 22. Hydraulic Hose

2. After draining, reconnect the hydraulic hose to vibrator.
3. Fill oil through breather hole of hand pump. Use **Shell Tellus Oil #46** or equivalent.
4. Removing the vibrator cylinder breather plug causes oil to flow out of breather hole for a while. When aeration disappears, replace the plug and tighten securely.

5. Replace breather plug of hand pump and fit the plug cap. After making sure that oil in pump is at proper level, replace the breather plug.

CAUTION - Over-filling the Hydraulic Oil

Make sure hydraulic oil in hand pump is at a normal operating level. **DO NOT** over fill. Over filling (excessive oil) will cause excess oil to blow out of breather plug.

Vibrator Oil Check

1. Place the compactor on a flat surface with the handle in the upright (storage) position.
2. Check the oil level by removing the vibrator oil gauge bolt using a 14 mm wrench as shown in Figure 23. The vibrator oil level should be maintained between the two markings as shown in Figure 7. If oil is required, replenish using SAE 10W-30.

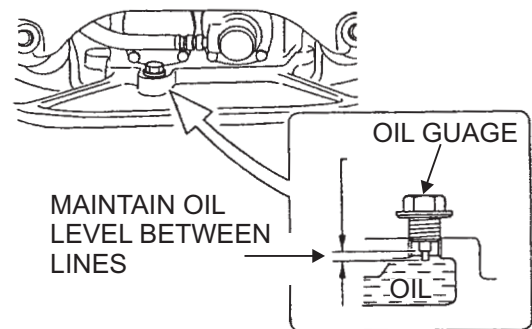
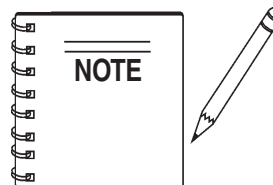

Figure 23. Vibrator Oil Gauge



Always clean the area around the vibrator oil level check hole before removing oil check plug. This will prevent dirt and debris from entering the system.

Replacing Vibrator Oil

The vibrator oil should be replaced every 300 hours of operation using engine oil 10W-30.

MVH-R60H — TROUBLESHOOTING (ENGINE)

Practically all breakdowns can be prevented by proper handling and maintenance inspections, but in the event of a breakdown, please take a remedial action following the diagnosis based on the Engine Troubleshooting (Tables 8) information shown below and on the proceeding pages. If the problem cannot be remedied, please leave the unit just as it is and consult our company's business office or service plant.

TABLE 8. ENGINE TROUBLESHOOTING

SYMPTOM	POSSIBLE CAUSE	SOLUTION
Difficult to start, "fuel is available, but no SPARK at spark plug".	Spark plug bridging?	Check gap, insulation or replace spark plug.
	Carbon deposit on spark plug?	Clean or replace spark plug.
	Short circuit due to deficient spark plug insulation?	Check spark plug insulation, replace if worn.
	Improper spark plug gap?	Set to proper gap.
Difficult to start, "fuel is available, and SPARK is present at the spark plug".	ON/OFF switch is shorted?	Check switch wiring, replace switch.
	Ignition coil defective?	Replace ignition coil.
	Improper spark gap, points dirty?	Set correct spark gap and clean points.
	Condenser insulation worn or short circuiting?	Replace condenser.
	Spark plug wire broken or short circuiting?	Replace defective spark plug wiring.
Difficult to start, "fuel is available, spark is present and compression is normal"	Wrong fuel type?	Flush fuel system, and replace with correct type of fuel.
	Water or dust in fuel system?	Flush fuel system.
	Air cleaner dirty?	Clean or replace air cleaner.
Difficult to start, "fuel is available, spark is present and compression is low"	Suction/exhaust valve stuck or protruded?	Re-seat valves.
	Piston ring and/or cylinder worn?	Replace piston rings and or piston.
	Cylinder head and/or spark plug not tightened properly?	Torque cylinder head bolts and spark plug.
	Head gasket and/or spark plug gasket damaged?	Replace head and spark plug gaskets.
No fuel present at carburetor.	Fuel not available in fuel tank?	Fill with correct type of fuel.
	Fuel cock does not open properly?	Apply lubricant to loosen fuel cock lever, replace if necessary.
	Fuel filter clogged?	Replace fuel filter.
	Fuel tank cap breather hole clogged?	Clean or replace fuel tank cap.
	Air in fuel line?	Bleed fuel line.

TABLE 8. ENGINE TROUBLESHOOTING (CONTINUED)

SYMPTOM	POSSIBLE CAUSE	SOLUTION
"Weak in power" compression is proper and does not misfire.	Air cleaner not clean?	Clean or replace air cleaner
	Improper level in carburetor?	Check float adjustment, re-build carbureator.
	Defective Spark plug?	Clean or replace spark plug.
"Weak in power" compression is proper but misfires.	Water in fuel system?	Flush fuel system, and replace with correct type of fuel.
	Dirty spark plug?	Clean or replace spark plug.
	Ignition coil defective?	Replace ignition coil.
Engine overheats.	Spark plug heat value improper?	Replace with correct type of spark plug.
	Correct type of fuel?	Replace with correct type of fuel
	Cooling fins dirty?	Clean cooling fins.
Rotational speed fluctuates.	Governor adjusted correctly?	Adjust governor.
	Governor spring defective?	Replace governor spring.
	Fuel flow restricted?	Check entire fuel system for leaks or clogs.
Recoil starter malfunction.	Recoil mechanism clogged with dust and dirt?	Clean recoil assembly with soap and water.
	Spiral spring loose?	Replace spiral spring.

MVH-R60H — TROUBLESHOOTING (PLATE COMPACTOR)

Practically all breakdowns can be prevented by proper handling and maintenance inspections, but in the event of a breakdown, please take a remedial action following the diagnosis based on the Compactor Troubleshooting (Tables 9) information shown below and on the proceeding pages. If the problem cannot be remedied, please leave the unit just as it is and consult our company's business office or service plant.

TABLE 9. PLATE COMPACTOR TROUBLESHOOTING

SYMPTOM	POSSIBLE CAUSE	SOLUTION
Travel speed too low, and vibration is weak.	Engine speed too low?	Set engine speed to correct RPM.
	Clutch slips?	Check or replace clutch.
	V-belt slips?	Adjust or replace V-belt.
	Excessive oil in vibrator?	Drain excess oil and fill to proper level.
	Malfunction in vibrator housing?	Check eccentric, gears and counter weights.
Travels forward or reverse, but impossible to switch direction.	Directional components defective?	Check all directional components
	Reversing lever adjustment?	Adjust or repair reversing lever.
	Hydraulic oil hose broken?	Repair or replace hydraulic oil hose.
	Aeration in hydraulic oil for reversing system?	Bleed hydraulic oil system.
	Check valve in hand pump clogged with dust?	Clean or replace hand pump check valve.
	Piston or bearing in cylinder (vibrator assy.) is defective?	If worn, replace cylinder piston or bearing.
Does not travel either forward or reverse.	V-belt slips?	Replace V-belt.
	Clutch slips?	Check clutch springs and shoes.
	Vibrator locked?	Check vibrator housing (eccentric, gears and counterweights)
	Piston or bearing in cylinder defective?	If worn, replace cylinder piston or bearing.
Travel lever operating resistance great.	Air in hydraulic line?	Bleed hydraulic oil system.
	Piston or bearing in cylinder defective?	If worn, replace cylinder piston or bearing.

MVH-R60H — EXPLANATION OF CODE IN REMARKS COLUMN

How to read the marks and remarks used in this parts book.

Items Found In the “Remarks” Column

Serial Numbers-Where indicated, this indicates a serial number range (inclusive) where a particular part is used.

Model Number-Where indicated, this shows that the corresponding part is utilized only with this specific model number or model number variant.

Items Found In the “Items Number” Column

All parts with same symbol in the number column, *, #, +, %, or >, belong to the same assembly or kit.

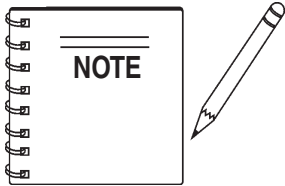

If more than one of the same reference number is listed, the last one listed indicates newest (or latest) part available.

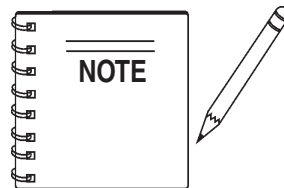

The contents of this catalog are subject to change without notice.

MVH-R60H with HONDA GX120K1SM12 ENGINE

1 to 5 Units

<u>Qty.</u>	<u>P/N</u>	<u>Description</u>
3	070100312	V-BELT
4	939010250	SHOCK ABSORBER
3	9807956846	SPARK PLUG
1	28462ZH8003 ...	ROPE, RECOIL STARTER
3	17210ZE0822 ...	ELEMENT, AIR CLEANER
1	17620ZH7023 ...	FUEL CAP
1	17672ZE2W01 .	FUEL FILTER, FUEL TANK

MVH-R60H — NAME PLATES AND DECALS

NAME PLATES ASSY.

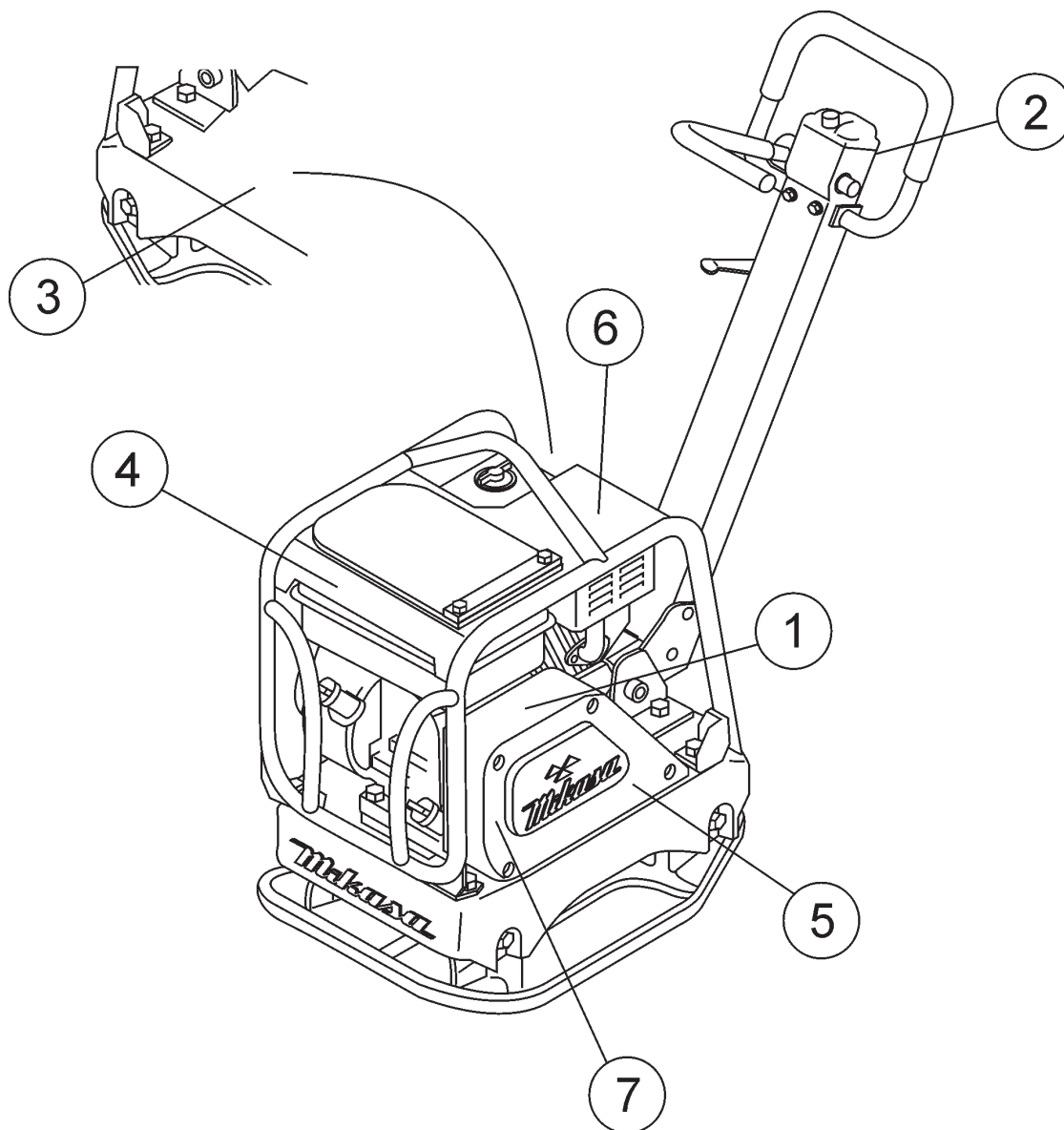

MVH-R60H — NAME PLATES AND DECALS

NAMEPLATE AND DECALS

<u>NO</u>	<u>PART NO</u>	<u>PART NAME</u>	<u>QTY.</u>	<u>REMARKS</u>
1	920201580	DECAL, MQ MARK 71X55	1	
2	920207480	DECAL, SHELL TELLUS OIL 46	1	
3		DECAL, SERIAL NO.	1 CONTACT PARTS DEPT.
4	920110000	DECAL, MVH-R60	1	
5	920207420	DECAL, V-BELT RPF-3320	1	
6	920209520	DECAL, OPERATIONAL CAUTION	1	
7	920201650	DECAL, OIL SAE 10W30	1	

MVH-R60H — CONTROL HANDLE ASSY.

CONTROL HANDLE ASSY.

<u>NO</u>	<u>PART NO</u>	<u>PART NAME</u>	<u>QTY.</u>	<u>REMARKS</u>
1	463342840	HANDLE	1	
2	463342860	BRACKET, HANDLE	1	
3	009120408	SUNK HEAD BOLT 8X20 T	5	
4	030208200	WASHER, LOCK M8	5	
5	031108160	WASHER, FLAT M8	5	
6	020308060	NUT M8	5	
6	022610808	FLANGE NUT M8 H	5	
8	001221464	BOLT 14X120 T	1	
9	031114260	WASHER, FLAT M14	2	
10	463456190	WASHER 14.4X32X0.6	2	
11	032114250	CONICAL SPRING WASHER M14	2	
12	020314110	NUT M14	2	
13	939010220	SHOCK ABSORBER, STOPPER	1	
14	022910220	WING NUT M12	1	
16	463342190	HAND PUMP ASSY.	1	
17	463342130	TRAVEL LEVER	1	
18	001520820	SOCKET HEAD BOLT 8X20 T	2	
19	458451420	COLLAR/MVH-120	1	
20	033910030	WAVE WASHER 15.5X20X0.3	4	
21	001220854	BOLT 8X70 T	2	
22	022130806	CAP NUT M8	2	
23	030208200	WASHER, LOCK M8	2	
24	031108160	WASHER, FLAT M8	2	
25	463342150	HANDLE GRIP	1	
26	954002620	OIL HOSE 730L	1	
26	954002621	OIL HOSE 780L	1	
27	954404230	CLAMP SA120-18	1	
28	001220620	BOLT 6X20 T	1	
29	020306050	NUT M6	1	
30	030206150	WASHER, LOCK M6	1	
31	031106100	WASHER, FLAT M6	1	
32	463455940	BREATHER CAP	1	
34	463455960	THROTTLE NUT	1	
35	001520510	SOCKET HEAD BOLT 5X10 T	1	

MVH-R60H — CONTROL HANDLE ASSY. (CONTINUED)

CONTROL HANDLE ASSY. (CONTINUED)

<u>NO</u>	<u>PART NO</u>	<u>PART NAME</u>	<u>QTY.</u>	<u>REMARKS</u>
36	463455950	SPACER, THROTTLE	1	
37	362341550	THROTTLE BODY	1	
38	362455610	THROTTLE GEAR	1	
39	362455630	THROTTLE LEVER	1	
40	362455620	SLIDER	1	
41	050100450	O-RING G-45	1	
42	050200100	O-RING P-10	1	
43	031110160	WASHER, FLAT M10	3	
44	033910070	CONICAL SPRING WASHER	2	
44	032110180	CONICAL SPRING WASHER M10	2	
45	096206006	SOCKET HEAD SCREW 6X6	1	
46	020410060	NUT M10, H+6	1	
47	022131008	CAP NUT M10	1	
48	096208020	SOCKET HEAD SCREW 8X20	1	
49	020408050	NUT M8, H+5	1	
50	956100047	THROTTLE WIRE 845-925	1	
51	001220625	BOLT 6X25 T	2	
52	030206150	WASHER, LOCK M6	2	
53	031106100	WASHER, FLAT M6	2	
54	511010040	CLAMP TC-300	1	

MVH-R60H — VIBRATOR ASSY.

VIBRATOR ASSY.

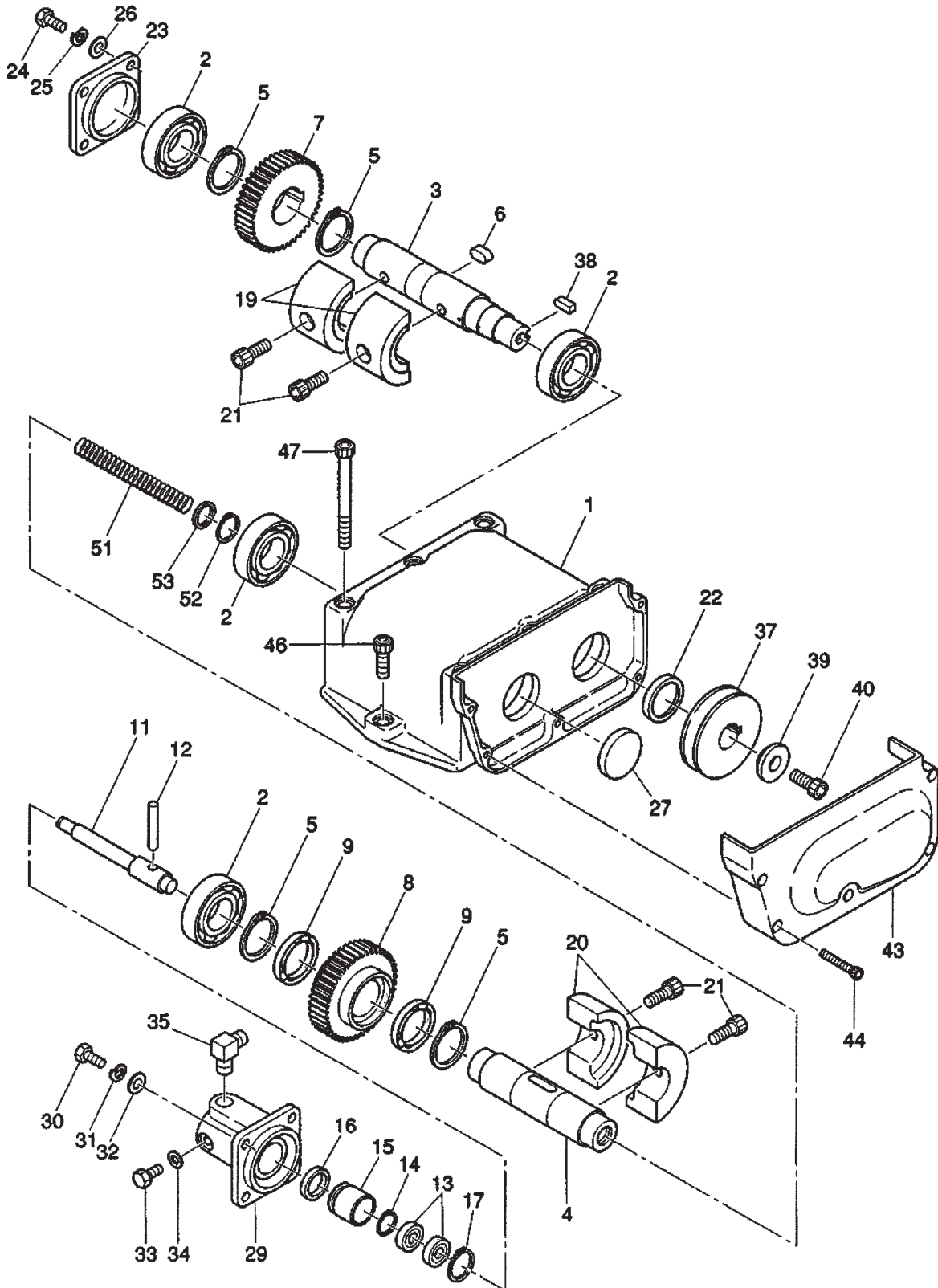

MVH-R60H — VIBRATOR ASSY.

VIBRATOR ASSY.

<u>NO</u>	<u>PART NO</u>	<u>PART NAME</u>	<u>QTY.</u>	<u>REMARKS</u>
1	463117150	VIBRATING CASE	1	
2	040406206	BEARING 6206C4	4	
3	463342040	ROTARY SHAFT, DRIVE	1	
4	463342050	ROTARY SHAFT, DRIVEN	1	
5	080200350	STOP RING S-35	4	
6	951405460	KEY 10X8X19 RR	1	
7	463342060	GEAR (DRIVE)	1	
8	463342070	GEAR (DRIVEN)	1	
9	040306807	BEARING 6807C3	2	
11	463342080	PISTON ROD	1	
12	025508045	PIN 8X45	1	
13	042506000	BEARING 6000ZZSG	2	
14	080200100	STOP RING S-10	1	
15	455435051	PISTON, 22.4D	1	
16	455010070	PACKING USH-22.4X30X5	1	
17	080100260	STOP RING R-26	1	
19	463455910	ECCENT. ROTATOR, DRIVE	2	
20	463455920	ECCENT. ROTATOR, DRIVEN	2	
21	009120304	SOCKET HEAD BOLT 10X25 T	4	
22	060202040	OIL SEAL SC-28458	1	
23	463455930	BEARING COVER	1	
24	001220820	BOLT 8X20 T	4	
25	030208200	WASHER, LOCK M8	4	
26	031108160	WASHER FLAT M8	4	
27	953405580	SEAL CAP SC-458	1	
29	463342090	CYLINDER	1	
30	001220820	BOLT 8X20 T	4	
31	030208200	WASHER, LOCK M8	4	
32	031108160	WASHER, FLAT M8	4	
33	001200812	BOLT 8X12	1	
34	953404600	COPPER PACKING 8X16X2	1	
35	954001160	ELBOW 90 DEG. PT1/4-PF1/4	1	
37	463342100	PULLEY 80D-A1	1	
38	951405240	KEY 7X7X19 R	1	
39	952406920	WASHER 9X(24-35)X10.5	1	
40	001520815	SOCKET HEAD BOLT 8X15 T	1	
43	463216110	BELT COVER (LOWER)	1	
44	001520640	SOCKET HEAD BOLT 6X40 T	5	
46	001521030	SOCKET HEAD BOLT 10X30 T	2	
47	001521060	SOCKET HEAD BOLT 10X100 T	6	
51	463456200	SPRING 1.2X15.6X130	1	
52	080100190	STOP RING R-19	1	
53	031108160	WASHER, FLAT M8	1	

MVH-R60H — BODY ASSY.

BODY ASSY.

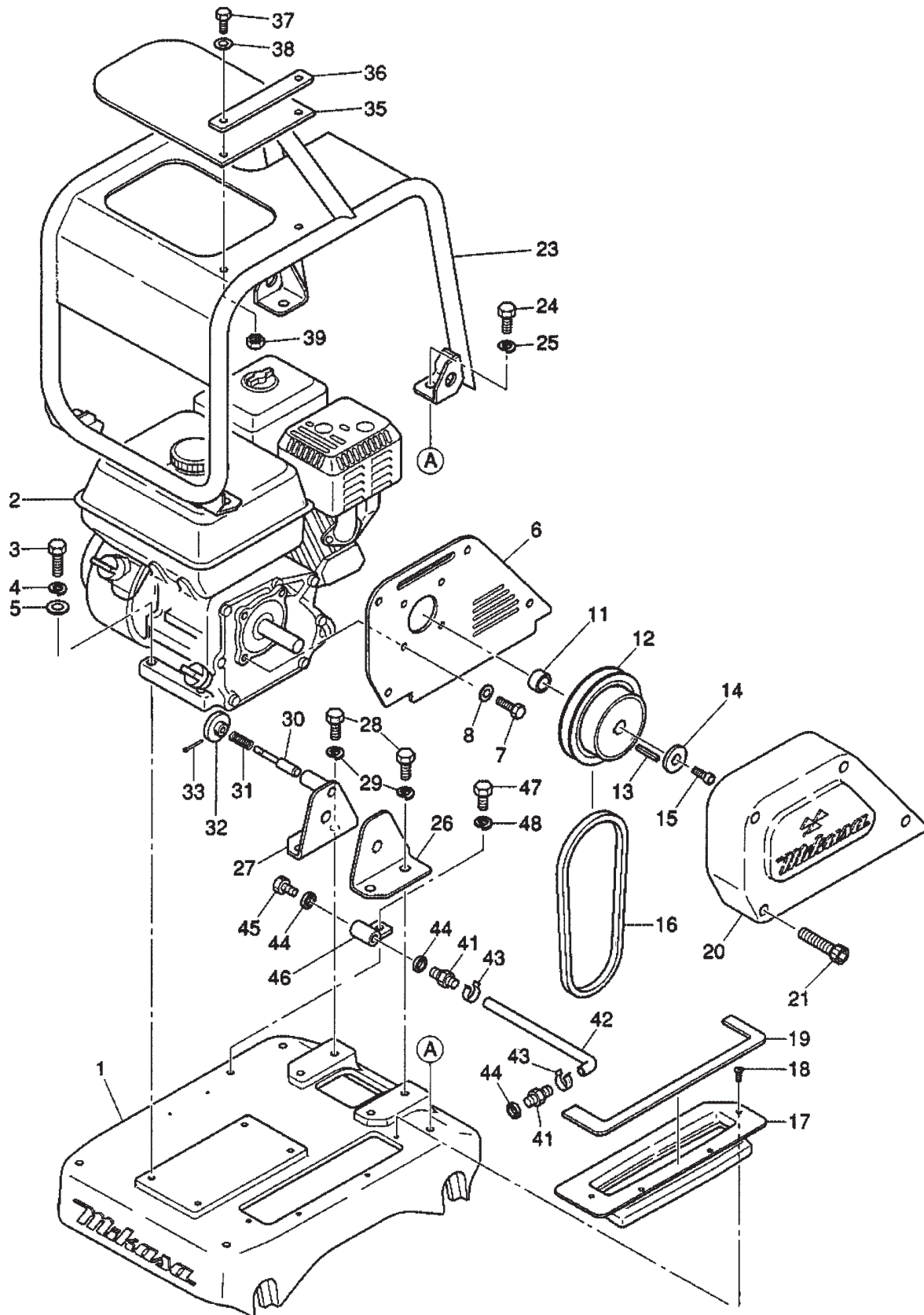

MVH-R60H — BODY ASSY.

BODY ASSY.

<u>NO</u>	<u>PART NO</u>	<u>PART NAME</u>	<u>QTY.</u>	<u>REMARKS</u>
1	463117120	BASE	1	
1	463117121	BASE (FRAME W/WATER TANK)	1	USE W/ ITEM 23 (GUARD FRAME W/ WATER TANK)
2	912212004	ENGINE AY GX120K1SM12	1	
3	001220840	BOLT 8X40 T	4	
4	030208200	WASHER, LOCK M8	4	
5	031108160	WASHER,FLAT M8	4	
6	463342160	BELT COVER PLATE	1	
7	001220820	BOLT 8X20 T	4	
8	030208200	WASHER, FLAT M8	4	
11	463455900	SPACER 18X25.4X13	1	
12	460446780	CLUTCH ASSY.	1	
13	951400100	KEY 5X5X35	1	
14	460446640	WASHER, CLUTCH	1	
15	001520825	SOCKET HEAD BOLT 8X25 T	1	
16	070100322	V-BELT RPF-3320	1	
17	463216120	DUST COVER	1	
18	092006010	FLAT HEAD SCREW 6X10	4	
19	463342030	SPONGE, DUST COVER	1	
20	463117140	BELT COVER	1	
21	001520854	SOCKET HEAD BOLT 8X70 T	4	
23	463117131	GUARD FRAME	1	
23	463117500	GUARD FRAME W/WATER TANK	1	
24	001221030	BOLT 10X30 T	4	
24	001221230	BOLT 12X30 T	4	USE W/ ITEM 23 (GUARD FRAME W/ WATER TANK)
25	030210250	WASHER, LOCK M10	4	
25	030212300	WASHER, LOCK M12	4	USE W/ ITEM 23 (GUARD FRAME W/ WATER TANK)
26	463342010	STAY (L), HANDLE	1	
27	463342020	STAY (R), HANDLE	1	
27	463342021	STAY (R), HANDLE	1	USE W/ ITEM 23 (GUARD FRAME W/ WATER TANK)
28	001221030	BOLT 10X30 T	4	
29	030210250	WASHER, LOCK M10	4	
30	458450860	STOPPER	1	
30	458450861	STOPPER	1	USE W/ ITEM 23 (GUARD FRAME W/ WATER TANK)
31	458450880	SPRING 1.2-10-29	1	
32	458450850	GRIP	1	
33	025402516	SPRING PIN 2.5X16	1	
35	458450830	RUBBER COVER	1	

MVH-R60H — BODY ASSY.

BODY ASSY.

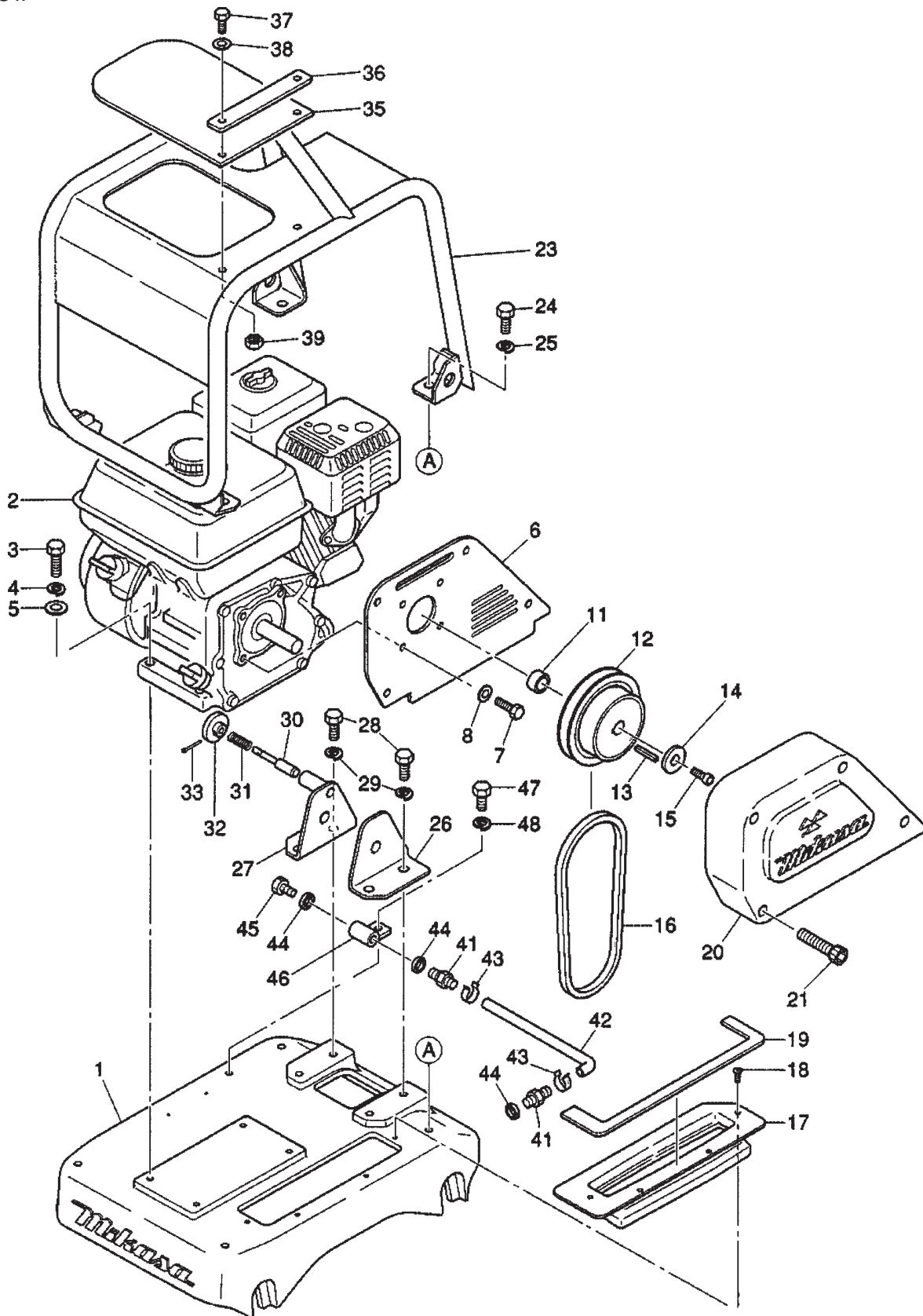

BODY ASSY.

<u>NO</u>	<u>PART NO</u>	<u>PART NAME</u>	<u>QTY.</u>	<u>REMARKS</u>
36	458450810	PLATE, RUBBER COVER	1	
37	001220825	BOLT 8X25 T	2	
38	031108160	WASHER, FLAT M8	2	
39	022710809	NYLON NUT M8	2	
41	15550ZK8P90	DRAIN JOINT	2	
42	15552ZB9000	DRAIN HOSE	1	
43	954010070	HOSE BAND 11.5D	2	
44	90601ZE1000	WASHER, DRAIN PLUG	3	
45	90131ZE1000	BOLT, DRAIN PLUG	1	
46	458450840	JOINT	1	
47	001220820	BOLT 8X20 T	1	
48	030208200	WASHER, LOCK M8	1	

MVH-R60H — VIBRATING PLATE ASSY.

VIBRATING PLATE ASSY.

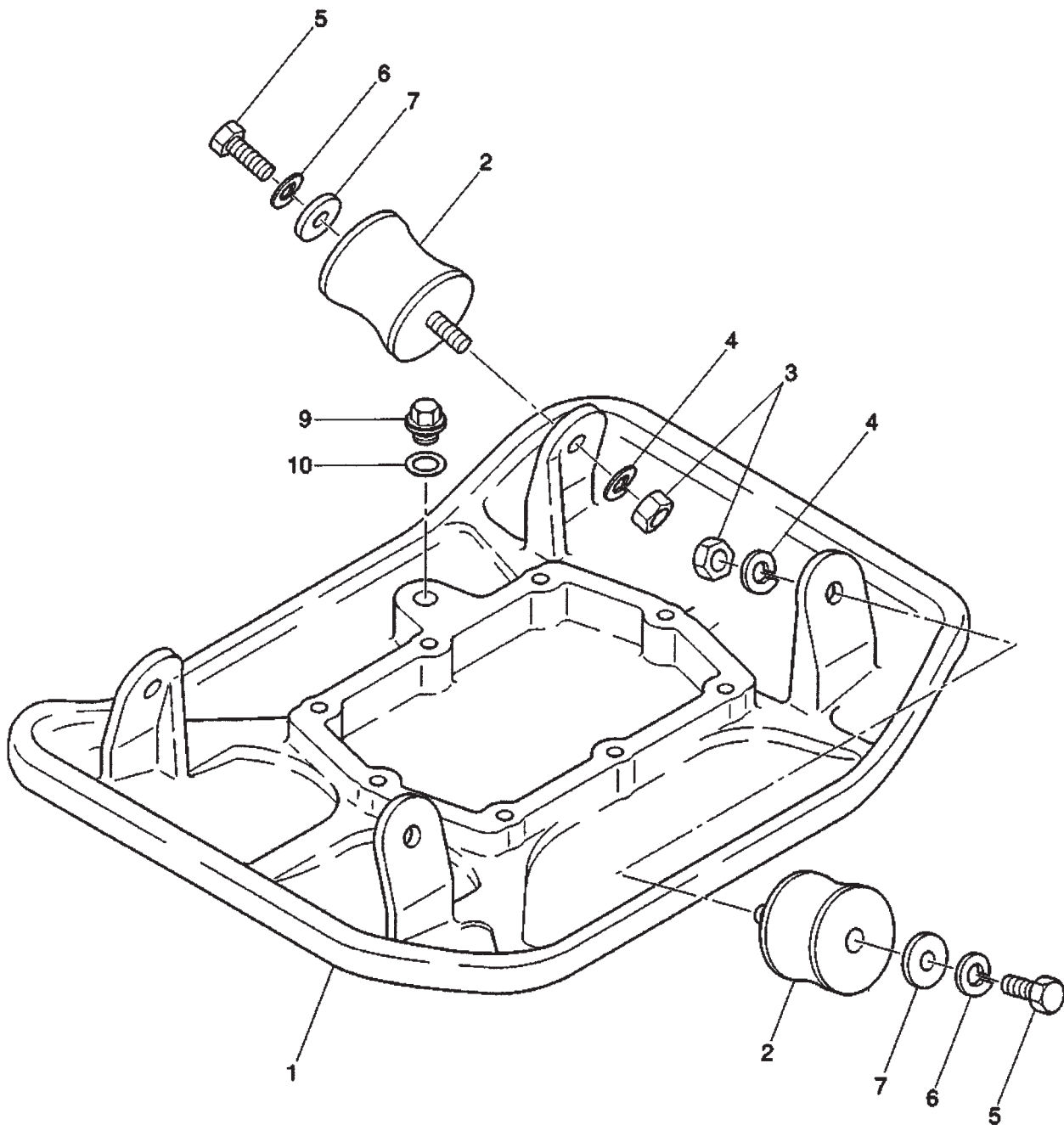

MVH-R60H — VIBRATING PLATE ASSY.

VIBRATING PLATE ASSY.

<u>NO</u>	<u>PART NO</u>	<u>PART NAME</u>	<u>QTY.</u>	<u>REMARKS</u>
1	463117110	VIBRATING PLATE	1	
2	939010160	SHOCK ABSORBER TAK-50	4	
3	020310080	NUT M10	4	
4	030210250	WASHER, LOCK M10	4	
5	001221030	BOLT 10X30 T	4	
6	030210250	WASHER, LOCK M10	4	
7	952401660	WASHER 103045	4	
9	460449160	OIL GAUGE	1	
10	953405260	PACKING 1/4 (CU)	1	

MVH-R60H — WATER TANK/SPRINKLER ASSY.

WATER TANK/SPRINKLER ASSY.

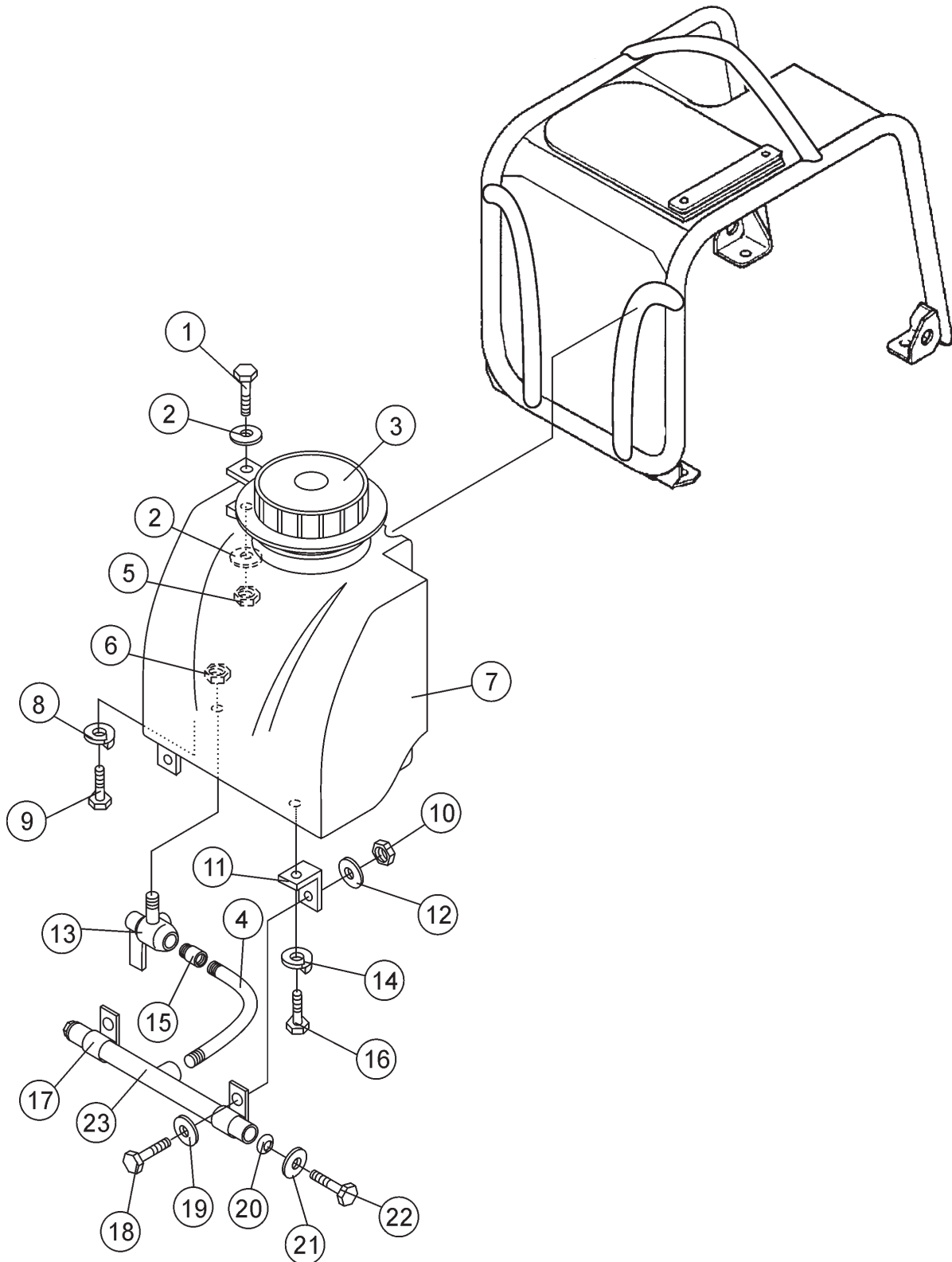

MVH-R60H — WATER TANK/SPRINKLER ASSY.

WATER TANK/SPRINKLER ASSY.

<u>NO</u>	<u>PART NO</u>	<u>PART NAME</u>	<u>QTY.</u>	<u>REMARKS</u>
1*	001241030	BOLT 10 X30	1	
2*	033910010	WASHER 10 MM 5 X 21 X 2	2	
3*	954300342	CAP, WATER TANK	1	
4	463456580	WATER HOSE	1	
5*	022910180	NYLON NUT M10	1	
6	022610808	FLANGE NUT M8	1	
7	463910010	WATER TANK ASSY.	1	INCLUDES ITEMS W/*
10	020306050	NUT M6	2	
11	463456570	L-TYPE STAY	2	
12	030206150	WASHER, LOCK M6	2	
13	954407090	HOOK ANGLE TYPE M8	1	
15	954405680	CONNECTOR 1/4 X 10	1	
16	001220615	BOLT 8X15	2	
17	954404230	CLAMP SA120--18	2	
18	001220615	BOLT 6 X15	2	
19	031106100	WASHER, FLAT	2	
20\$	515910050	CAP ASSY. W/BOLT AND WASHER	2	INCLUDES ITEMS W/#
21\$#	031106100	WASHER, M6	2	
22\$#	001220620	BOLT, 6X20	2	
23	463342970	SPRINKLING PIPE	1	INCLUDES ITEMS W/\$
24	458450830	RUBBER COVER	1	
25	001220825	BOLT 8X25	2	
26	031108160	WASHER, FLAT	2	
27	458450810	PLATE, RUBBER COVER	1	
28	022710809	NYLON NUT M8	2	
29	001221230	BOLT 12 X30	4	
30	030212300	WASHER, LOCK M12	4	

HONDA GX120K1SM12 ENGINE — CYLINDER HEAD ASSY.

CYLINDER HEAD ASSY.

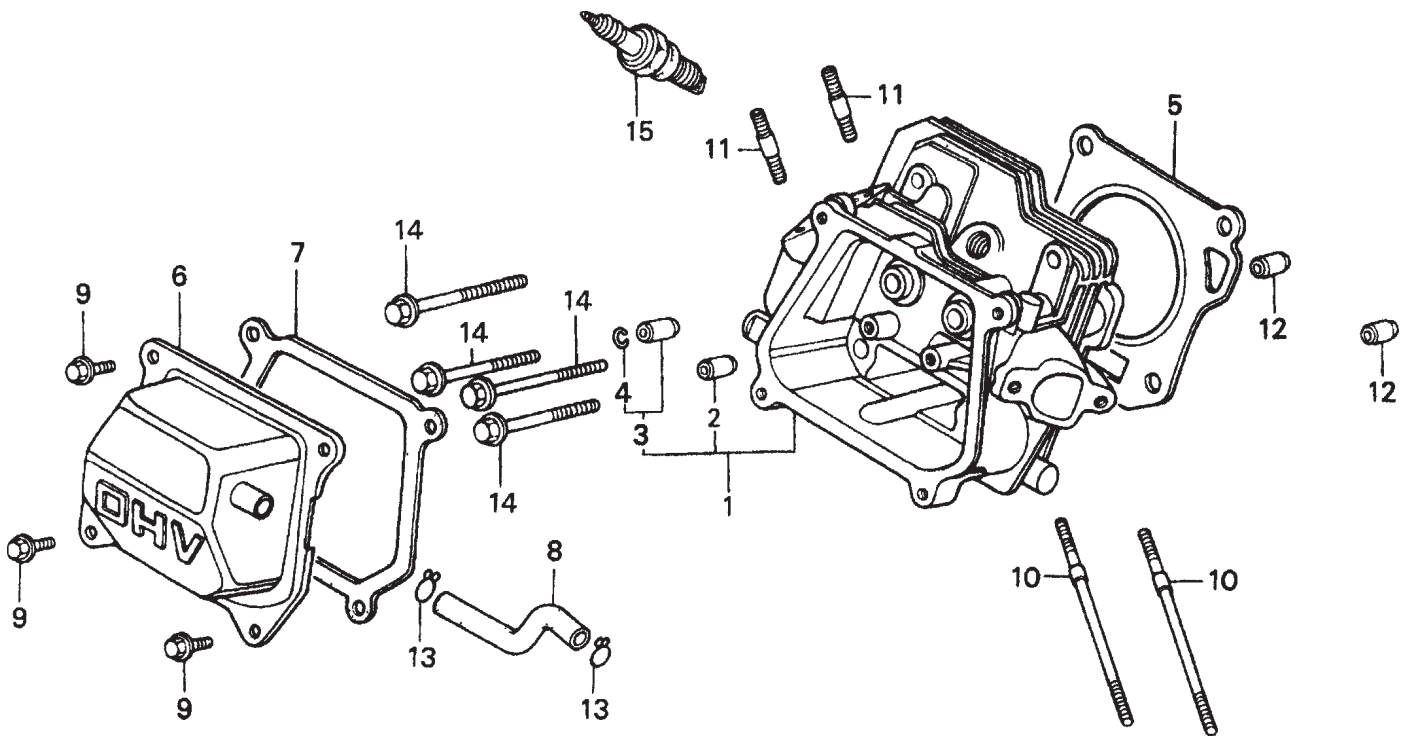

HONDA GX120K1SM12 ENGINE — CYLINDER HEAD ASSY.

CYLINDER HEAD ASSY.

NO.	PART NO.	PART NAME	QTY.	REMARKS
1	12210ZH7000	CYLINDER HEAD	1	INCLUDES ITEMS W/*
2*	12204ZE1306	GUIDE, VALVE (OS) OPTIONAL	1	
3*	12205ZE1315	GUIDE, EX. VALVE (OS) OPTIONAL	1	INCLUDES ITEMS W/+
4*+	12216ZE5300	CLIP, VALVE GUIDE	1	
5	12251ZH7800	GASKET, CYLINDER HEAD	1	
6	12310ZE1020	COVER, HEAD	1	
7	12391ZE1000	GASKET, CYLINDER HEAD COVER	1	
8	15721ZH8000	TUBE, BREATHER	1	
9	90013883000	BOLT, FLANGE 6X12 (CT200)	4	
10	90043ZE1020	BOLT, STUD 6X109	2	
11	90047ZE1000	BOLT, STUD 8X32	2	
12	9430110160	PIN, A, DOWEL 10X16	2	
14	957230805500	BOLT, FLANGE 8X55	4	
15	9807956846	SPARK PLUG BPR6ES (NGK)	1	

HONDA GX120K1SM12 ENGINE — CYLINDER BARREL ASSY.

CYLINDER BARREL ASSY.

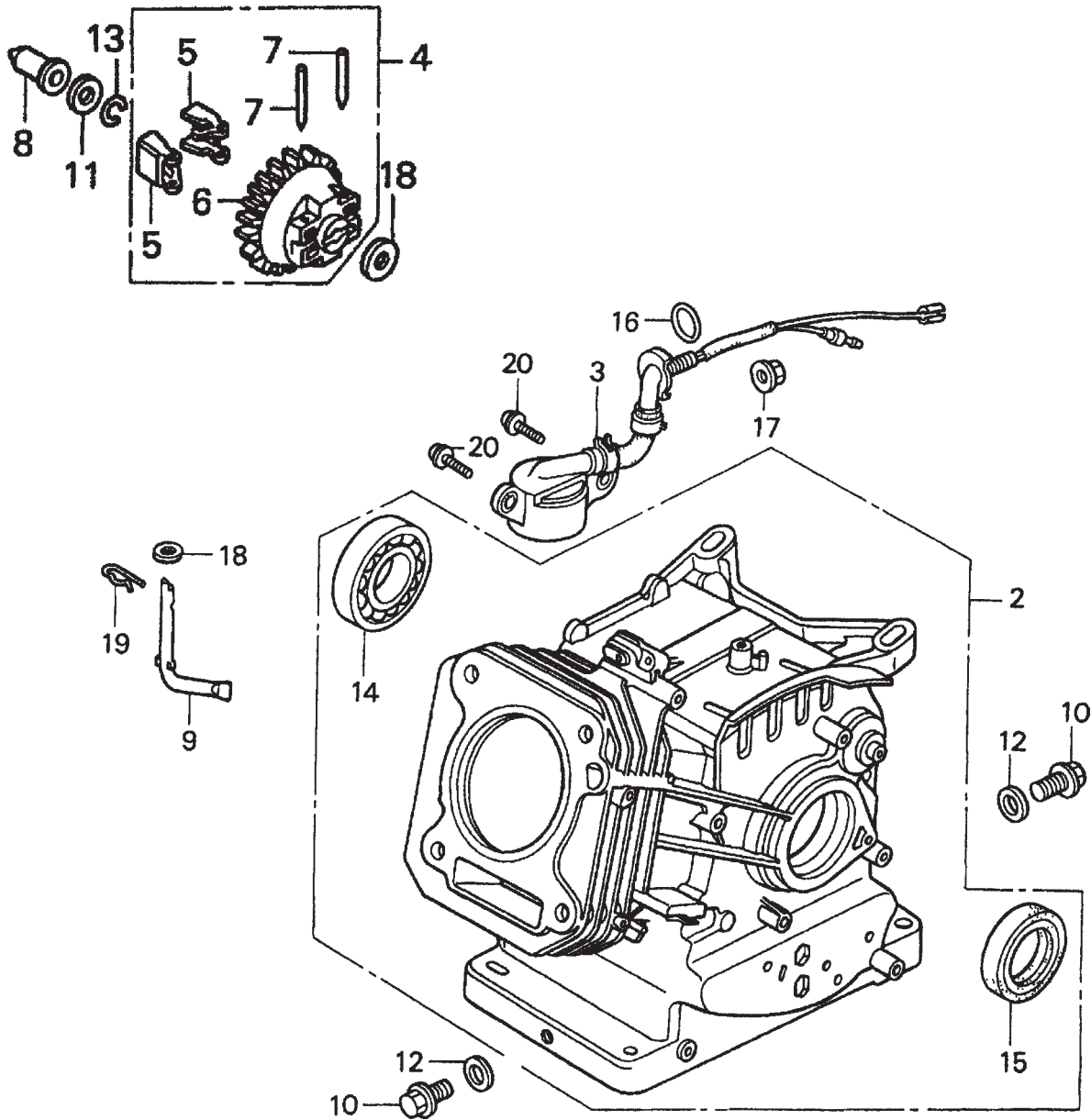

HONDA GX120K1SM12 ENGINE — CYLINDER BARREL ASSY.

CYLINDER BARREL ASSY.

<u>NO.</u>	<u>PART NO.</u>	<u>PART NAME</u>	<u>QTY.</u>	<u>REMARKS</u>
2	120A0ZH7810	BARREL ASSY., CYLINDER	1	INCLUDES ITEMS W/*
3	15510ZE1033	SWITCH ASSY., OIL LEVEL	1	
4	16510ZE1000	GOVERNOR ASSY.	1	INCLUDES ITEMS W/#
5#	16511ZE1000	WEIGHT, GOVERNOR	2	
6#	16512ZE1000	HOLDER, GOVERNOR WEIGHT	1	
7#	16513ZE1000	PIN, GOVERNOR WEIGHT	2	
8	16531ZE1000	SLIDER, GOVERNOR	1	
9	16541ZE1000	SHAFT, GOVERNOR ARM	1	
10	90131ZE1000	BOLT, DRAIN PLUG	2	
11	90451ZE1000	WASHER, THRUST 6mm	1	
12	90601ZE1000	WASHER, DRAIN PLUG 10.2mm	2	
13	90602ZE1000	CLIP, GOVERNOR HOLDER	1	
14*	91001878003	BEARING, RADIAL BALL 62/22	1	
15*	91202ZE6003	OIL SEAL 22X35X6	1	
16	91353671004	O- RING 14mm	1	
17	9405010000	NUT, FLANGE 10mm	1	
18	9410106800	WASHER, PLAIN 6mm	2	
19	9425108000	PIN, LOCK 8mm	1	
20	957010601200	BOLT, FLANGE 6X12	2	

HONDA GX120K1SM12 ENGINE — CRANKCASE COVER ASSY.

CRANKCASE COVER ASSY.

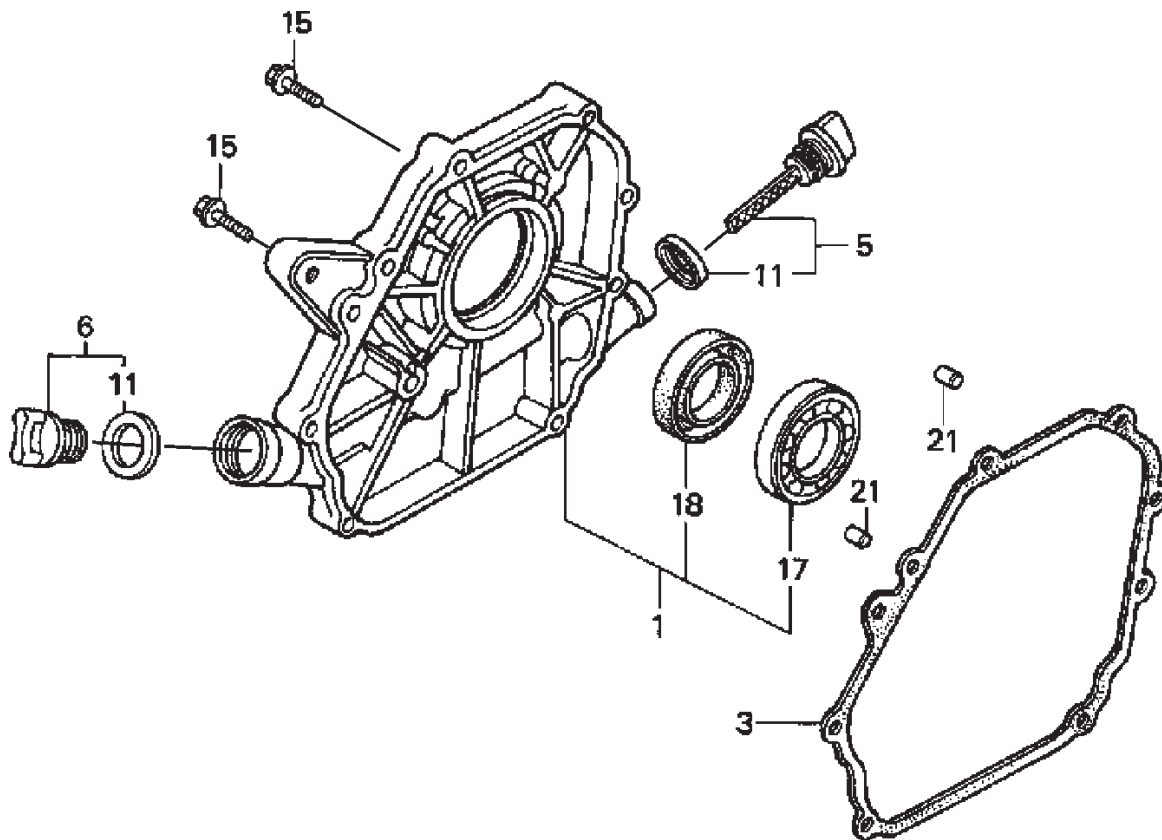

HONDA GX120K1SM12 ENGINE — CRANKCASE COVER ASSY.

CRANKCASE COVER ASSY.

<u>NO.</u>	<u>PART NO.</u>	<u>PART NAME</u>	<u>QTY.</u>	<u>REMARKS</u>
1	11300ZE0640	COVER ASSY., CRANKCASE	1	INCLUDES ITEMS W/*
3	11381ZH7800	GASKET, CRANKCASE	1	
5	15600ZE1003	CAP ASSY., OIL FILLER	1	INCLUDES ITEMS W/#
6	15600ZG4003	CAP ASSY., OIL FILLER	1	INCLUDES ITEMS W/+
11#+	15625ZE1003	PACKING, OIL FILLER CAP	2	
15	90015883000	BOLT, FLANGE 6X28	7	
17*	91001878003	BEARING, RADIAL 62/22	1	
18*	91203ZE0003	OIL SEAL 22X41X6	1	
21	9430108140	DOWEL PIN 8X14	2	

HONDA GX120K1SM12 ENGINE — CRANKSHAFT ASSY.

CRANKSHAFT ASSY.

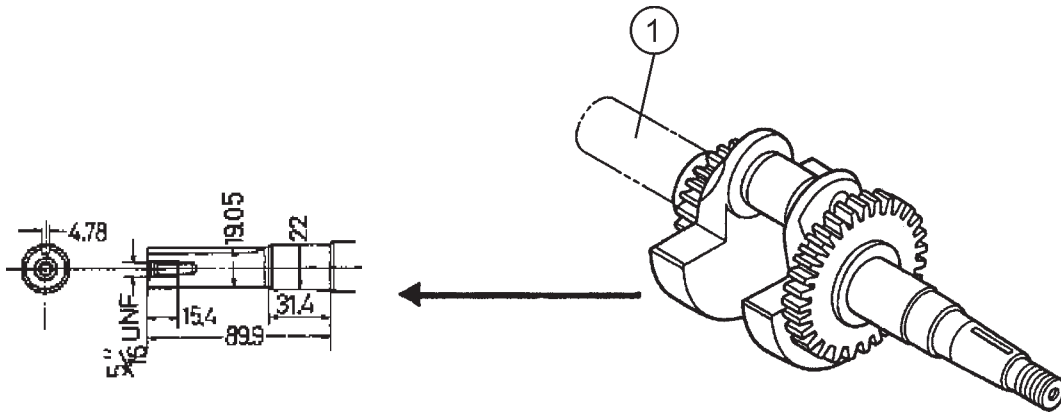

HONDA GX120K1SM12 ENGINE — CRANKSHAFT ASSY.

CRANKSHAFT ASSY.

<u>NO.</u>	<u>PART NO.</u>	<u>PART NAME</u>	<u>QTY.</u>	<u>REMARKS</u>
1	13310ZE0601	CRANKSHAFT	1	

HONDA GX120K1SM12 ENGINE — PISTON/CONNECTING ROD ASSY.

PISTON/CONNECTING ROD ASSY.

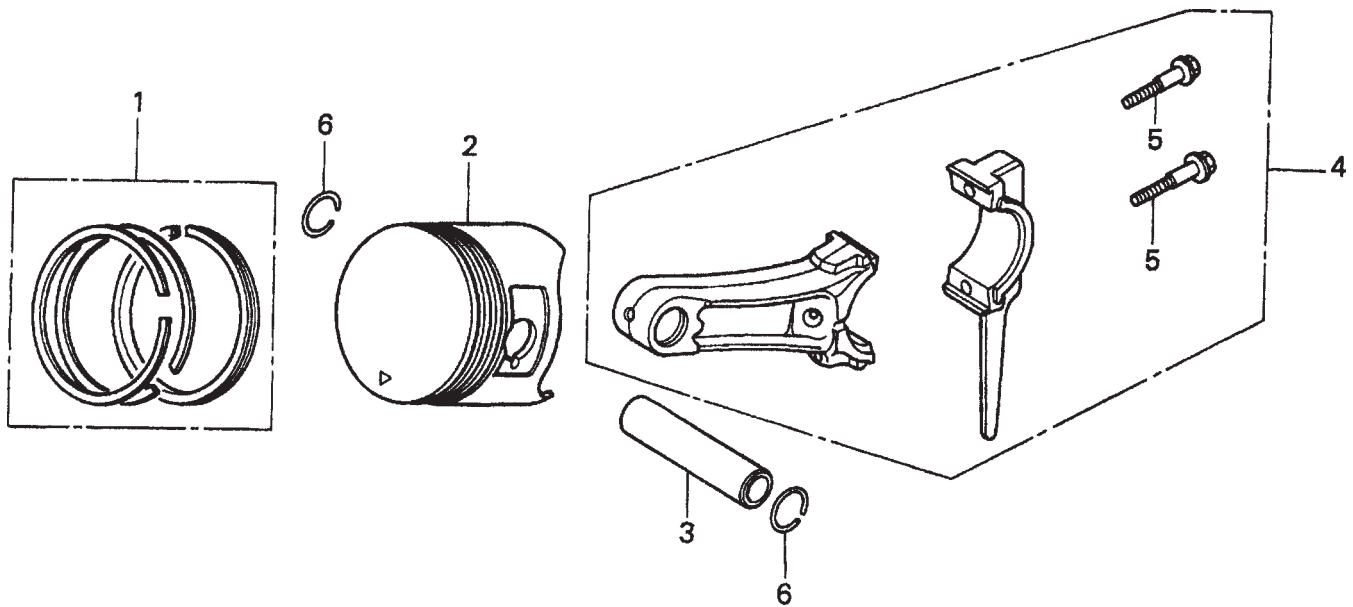

HONDA GX120K1SM12 ENGINE — PISTON/CONNECTING ROD ASSY.

PISTON/CONNECTING ROD ASSY.

<u>NO.</u>	<u>PART NO.</u>	<u>PART NAME</u>	<u>QTY.</u>	<u>REMARKS</u>
1	13010ZK7V01	RING SET, PISTON (STANDARD)	1	
1	13011ZK7V01	RING SET, PISTON (OS 0.25), OPTIONAL	1	
1	13012ZK7V01	RING SET, PISTON (OS 0.50) , OPTIONAL	1	
1	13013ZK7V01	RING SET, PISTON (OS 0.75), OPTIONAL	1	
2	13101ZH7000	PISTON, STANDARD	1	
2	13102ZH7000	PISTON, OS 0.25	1	
2	13103ZH7000	PISTON, OS 0.50	1	
2	13104ZH7000	PISTON, 0.75	1	
3	13111ZE0000	PIN, PISTON	1	
4	132A0ZE0000	ROD ASSY, CONNECTING (UNDER SIZE)	1	INCLUDES ITEMS W/*
4	13200ZE0000	ROD ASSY., CONNECTING	1	INCLUDES ITEMS W/*
5*	90001ZE1000	BOLT, CONNECTING ROD	2	
6	90551ZE0000	CLIP, PISTON PIN 13MM	2	

HONDA GX120K1SM12 ENGINE — CAMSHAFT ASSY.

CAMSHAFT ASSY.

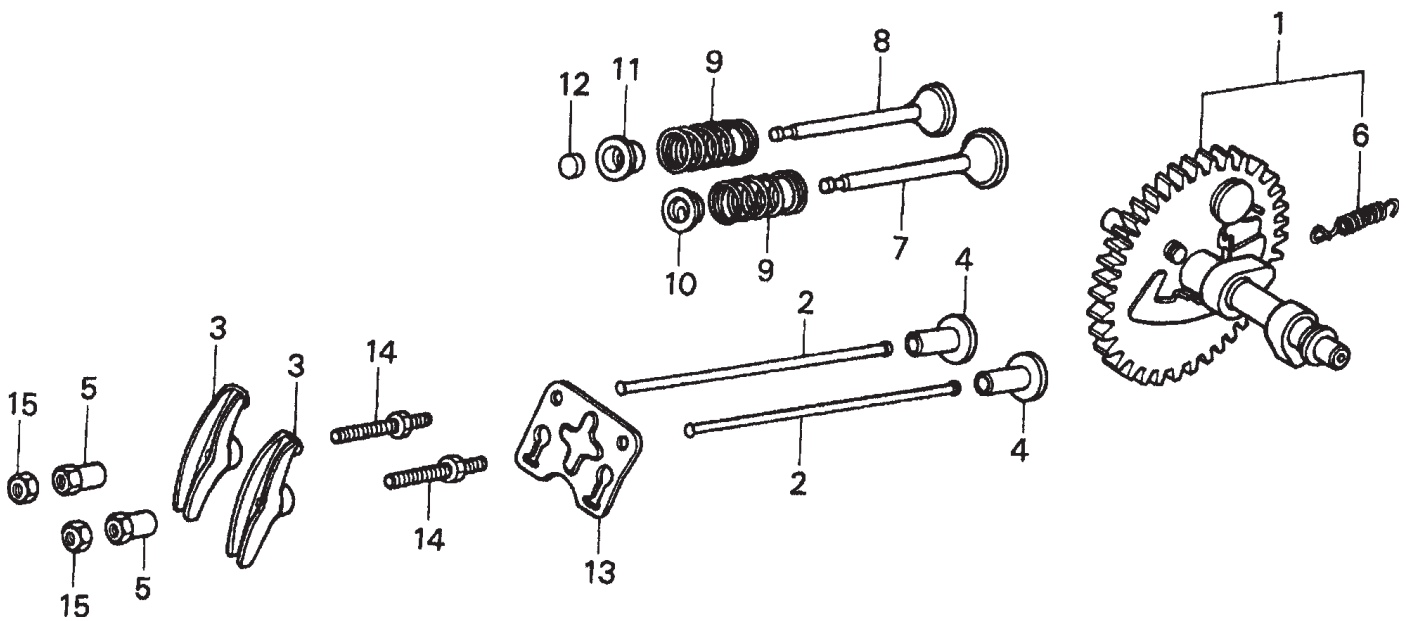

HONDA GX120K1SM12 ENGINE — CAMSHAFT ASSY.

CAMSHAFT ASSY.

<u>NO.</u>	<u>PART NO.</u>	<u>PART NAME</u>	<u>QTY.</u>	<u>REMARKS</u>
1	14100ZE0812	CAMSHAFT ASSY.	1	INCLUDES ITEMS W/*
2	14410ZE0010	ROD, PUSH	2	
3	14431ZE1000	ARM, VALVE ROCKER	2	
4	14441ZE1010	LIFTER, VALVE	2	
5	14451ZE1013	PIVOT, ROCKER ARM	2	
6*	14568ZE1000	SPRING, WEIGHT RETURN	1	
7	14711ZF0000	VALVE, IN.	1	
8	14721ZF0000	VALVE, EX.	1	
9	14751ZF1000	SPRING, VALVE	2	
10	14771ZE1000	RETAINER, IN. VALVE SPRING	1	
11	14773ZE1000	RETAINER, EX. VALVE SPRING	1	
12	14781ZE1000	ROTATOR, VALVE	1	
13	14791ZE0010	PLATE, PUSH ROD GUIDE	1	
14	90012ZE0010	BOLT, PIVOT 8MM	2	
15	90206ZE1000	NUT, PIVOT ADJ.	2	

HONDA GX120K1SM12 ENGINE — RECOIL STARTER ASSY.

RECOIL STARTER ASSY.

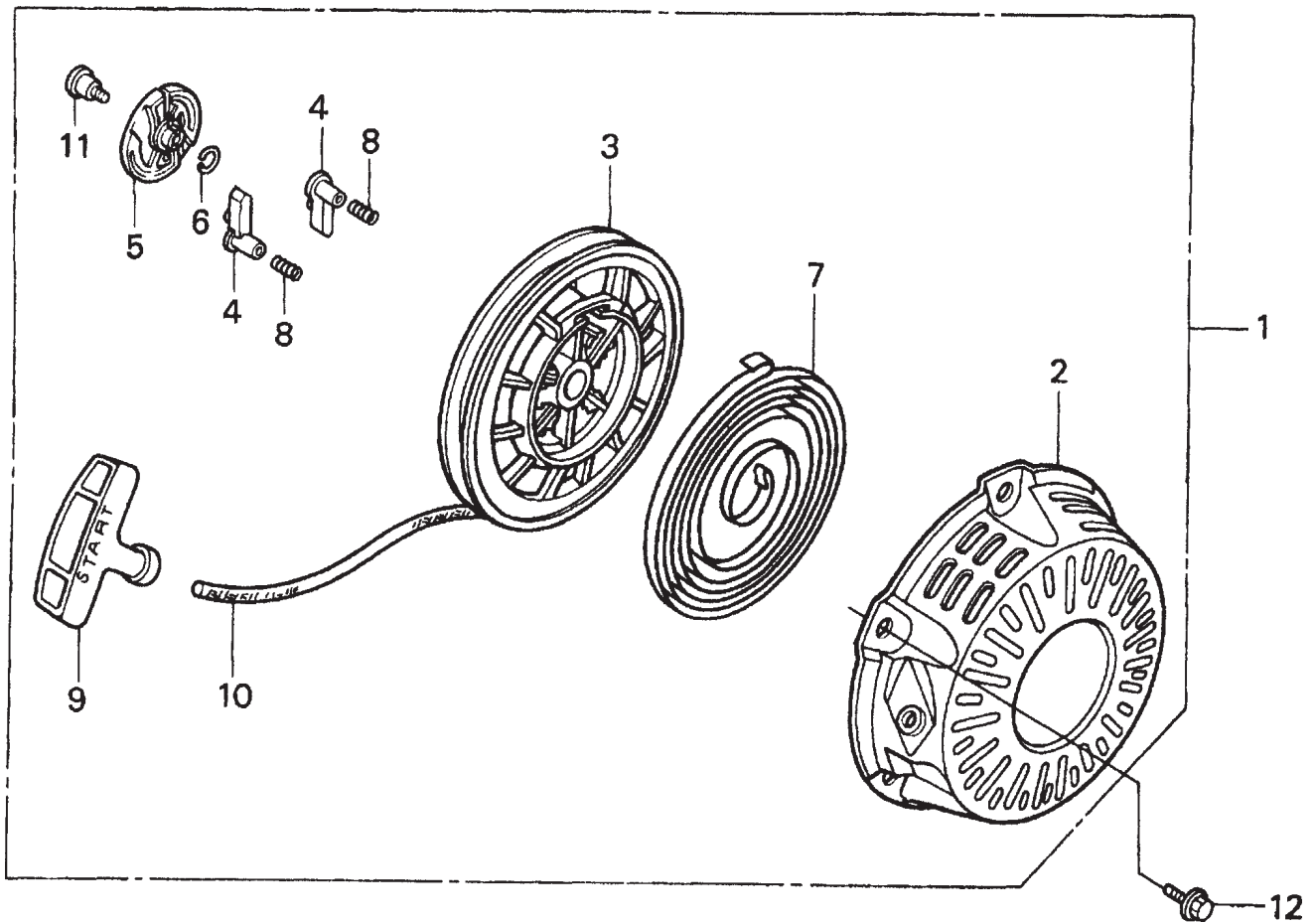

HONDA GX120K1SM12 ENGINE — RECOIL STARTER ASSY.

RECOIL STARTER ASSY.

NO.	PART NO.	PART NAME	QTY.	REMARKS
1	28400ZH8013ZA	STARTER ASSY., RECOIL *NH1* (BLACK)	1	INCLUDES ITEMS W/*
2*	28410ZH8003ZA	CASE, RECOIL STARTER *NH1* (BLACK)	1	
3*	28420ZH8013	REEL, RECOIL STARTER	1	
4*	28422ZH8013	RATCHET, STARTER	2	
5*	28433ZH8003	GUIDE, RATCHET	1	
6*	28441ZH8003	SPRING, FRICTION	1	
7*	28442ZH8003	SPRING, RECOIL STARTER	1	
8*	28443ZH8003	SPRING, RETURN	2	
9*	28461ZH8003	KNOB, RECOIL STARTER	1	
10*	28462ZH8003	ROPE, RECOIL STARTER	1	
11*	90003ZH8003	SCREW, SETTING	1	
12	9008ZE2003	BOLT, FLANGE 6X10	3	

HONDA GX120K1SM12 ENGINE — FAN COVER ASSY.

FAN COVER ASSY.

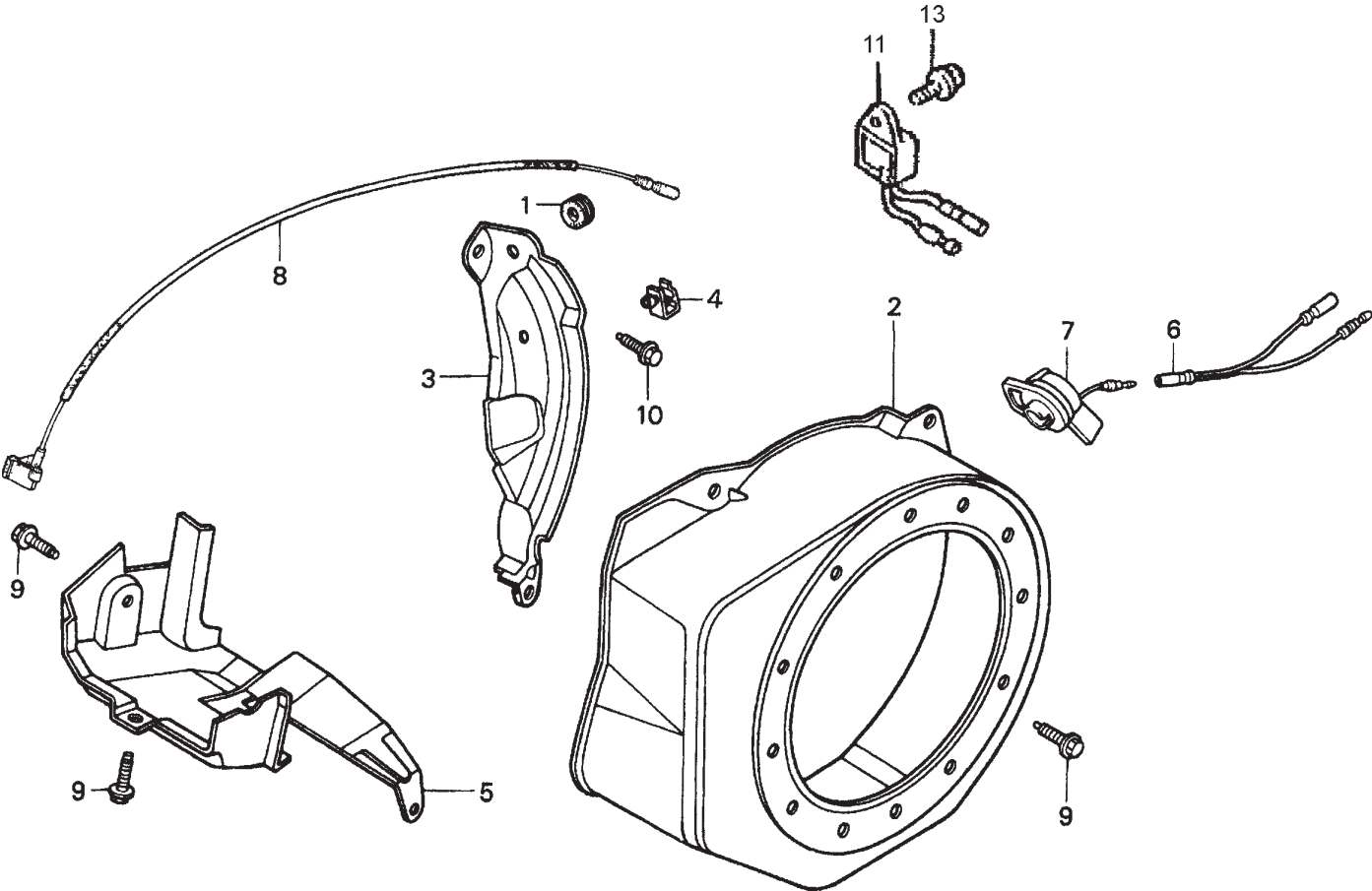

HONDA GX120K1SM12 ENGINE — FAN COVER ASSY.

FAN COVER ASSY.

<u>NO.</u>	<u>PART NO.</u>	<u>PART NAME</u>	<u>QTY.</u>	<u>REMARKS</u>
1	11347371300	GROMMET, ADJUSTING COVER	1	
2	19610ZE0000ZA	COVER, FAN RED	1	
3	19611ZH7810	PLATE, SIDE (OIL ALERT)	1	
4	90601ZH7013	CLIP, HARNESS	1	
5	19630ZH7000	SHROUD	1	
6	32197ZH8003	SUB- HARNESS	1	
7	36100ZH7003	SWITCH ASSEMBLY, ENGINE STOP	1	
8	36101ZE1010	WIRE, STOP SWITCH 370MM	1	
9	90013883000	BOLT, FLANGE 6X12 (CT200)	6	
10	90022888010	BOLT, FLANGE 6X12 (CT200)	1	
11	34150ZH7003	ALERT UNIT, OIL	1	
13	95 7010600800	BOLT, FLANGE 6X8	1	

HONDA GX120K1SM12 ENGINE — CARBURETOR ASSY.

CARBURETOR ASSY.

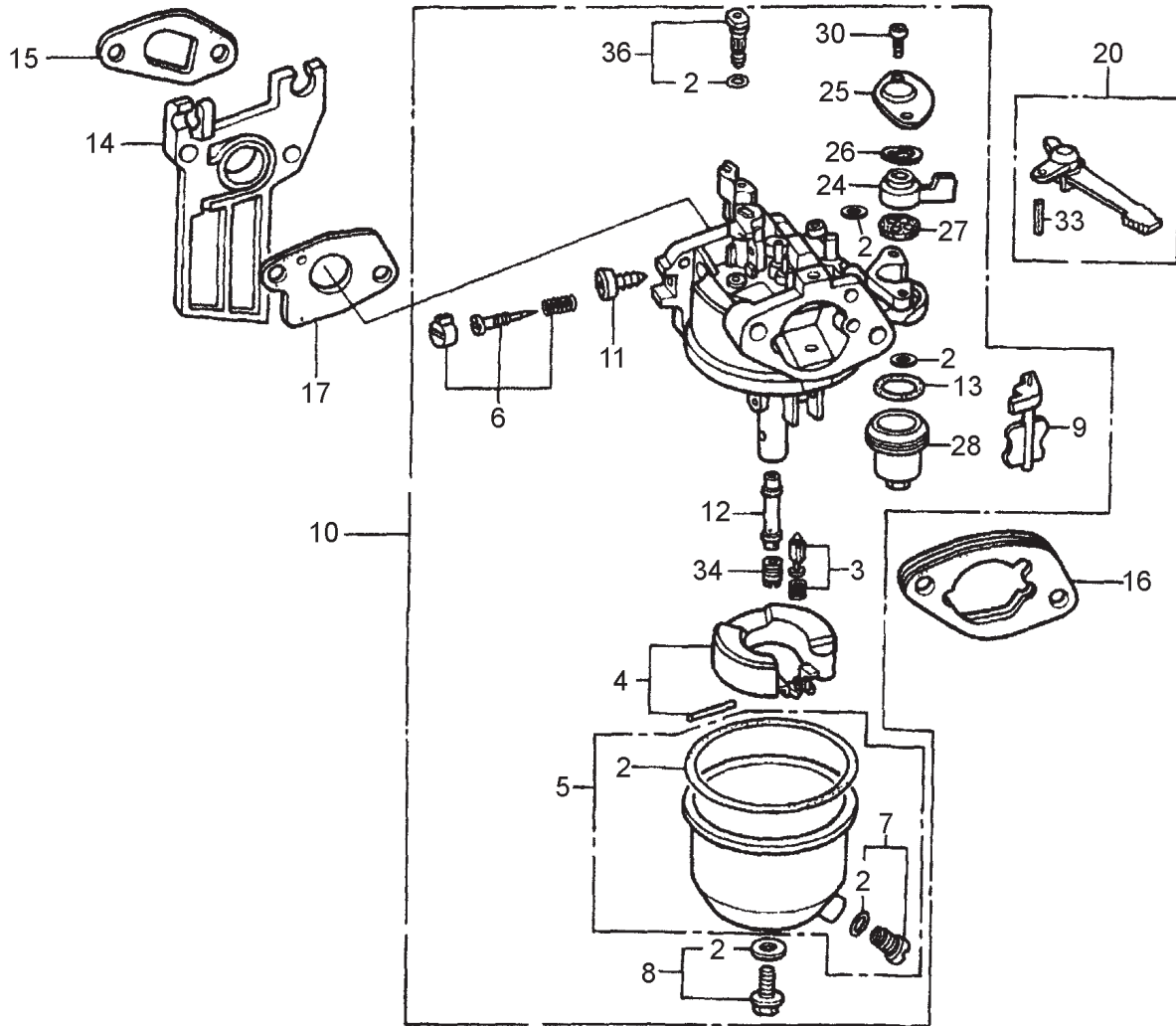

HONDA GX120K1SM12 ENGINE — CARBURETOR ASSY.

CARBURETOR ASSY.

<u>NO.</u>	<u>PART NO.</u>	<u>PART NAME</u>	<u>QTY.</u>	<u>REMARKS</u>
2*#	16010ZE1812	GASKET SET	1	
3*	16011ZE0005	VALVE SET, FLOAT	1	
4*	16013ZE0005	FLOAT SET	1	
5*	16015ZE0831	FLOAT CHAMBER SET	1	INCLUDES ITEMS W/#
7*#	16024ZE1811	DRAIN SCREW SET	1	
8*	16028ZE0005	SCREW SET B	1	
9*	16044ZE0005	CHOKE SET	1	
10	16100ZH7W51	CARBURETOR ASSY., BE60B B	1	INCLUDES ITEMS W/*
11*	16124ZE0005	SCREW, THROTTLE STOP	1	
12*	16166ZH7W50	NOZZLE, MAIN	1	
13*	16173001004	PACKING, CUP	1	
14	16211ZE0000	INSULATOR, CARBURETOR	1	
15	16212ZH7800	PACKING, INSULATOR	1	
16	16220ZE1020	SPACER, CARBURETOR	1	
17	16221ZH8801	GASKET, CARBURETOR	1	
20	16610ZE1000	LEVER, CHOKE (STANDARD)	1	INCLUDES ITEMS W/+
24*	16953ZE1812	LEVER, VALVE	1	
25*	16954ZE1812	PLATE, LEVER SETTING	1	
26*	16956ZE1811	SPRING, VALVE LEVER	1	
27*	16957ZE1812	GASKET, VALVE	1	
28*	16967ZE0811	CUP, FUEL STRAINER	1	
30*	93500030061H	SCREW, PAN (3 X 6)	2	
33+	9430520122	PIN, SPRING (2 X 12)	1	
34*	99101ZH80600	JET, MAIN (#60)	1	
35*	99204ZE00350	JET, SET, PILOT (#35)	1	
36	16016ZH7W01	SCREW SET	1	

HONDA GX120K1SM12 ENGINE — AIR CLEANER ASSY.

AIR CLEANER ASSY.

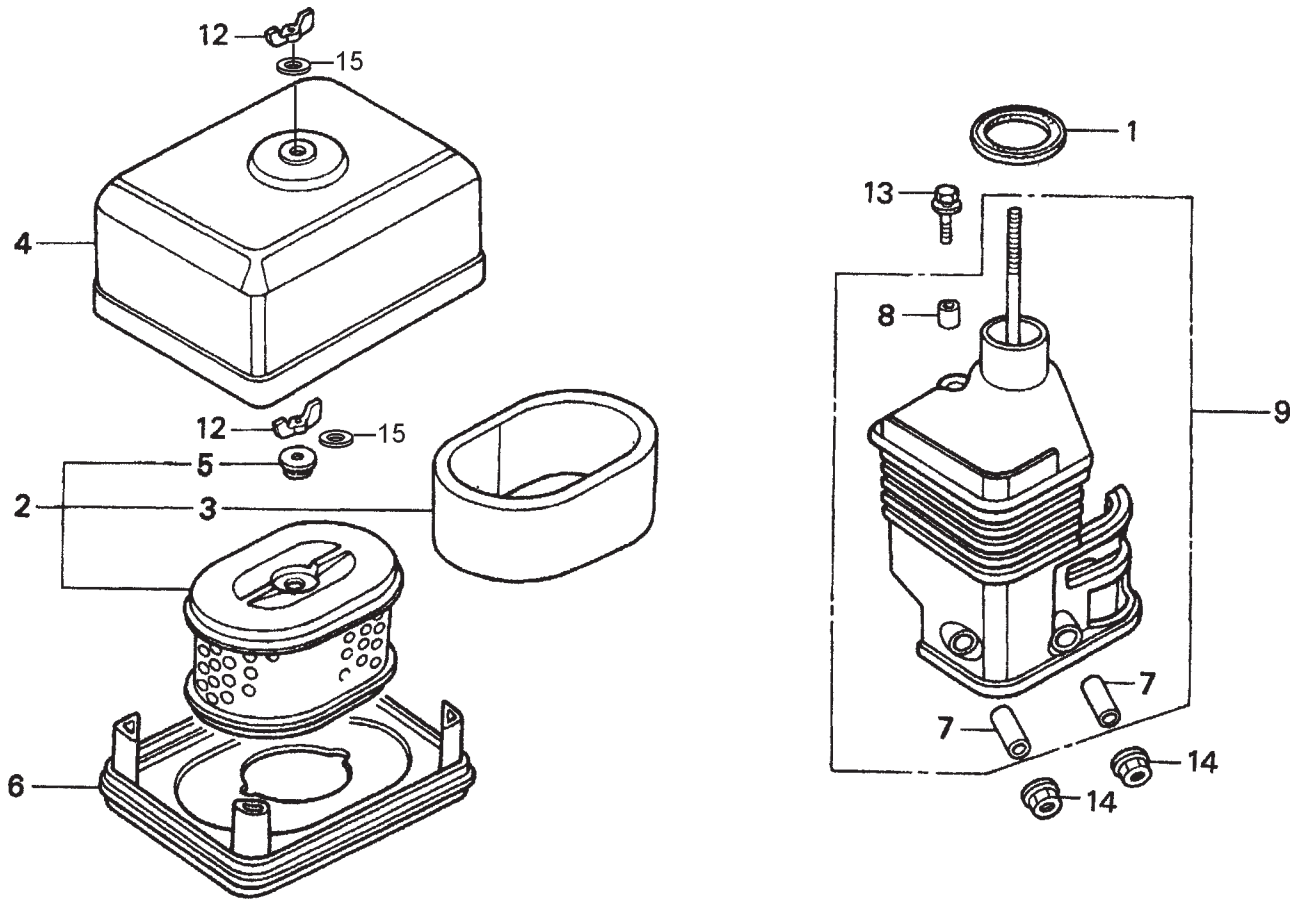

HONDA GX120K1SM12 ENGINE — AIR CLEANER ASSY.

AIR CLEANER ASSY.

<u>NO.</u>	<u>PART NO.</u>	<u>PART NAME</u>	<u>QTY.</u>	<u>REMARKS</u>
1	16271ZE1000	GASKET, ELBOW	1	
2	17210ZE0822	CLEANER ELEMENT	1	INCLUDES ITEMS W/#
3#	17218ZE0821	ELEMENT OUTER	1	
4	17230ZE0820	COVER, AIR CLEANER	1	
5#	17232891000	GROMMET, AIR CLEANER	1	
6	17235ZE1831	NOSE, SILENCER	1	
7*	17238ZE0010	COLLAR, AIR CLEANER	2	
8*	17239ZE1000	COLLAR B, AIR CLEANER	1	
9	17410ZE0030	ELBOW, AIR CLEANER	1	INCLUDES ITEMS W/*
12	90325044000	WINGNUT, TOOL BOX SETTING	2	
13	957010602000	BOLT, FLANGE 6X20	1	
14	9405006000	NUT, FLANGE 6MM	2	
15	9410106800	PLAIN WASHER 6MM	2	

HONDA GX120K1SM12 ENGINE — MUFFLER ASSY.

MUFFLER ASSY.

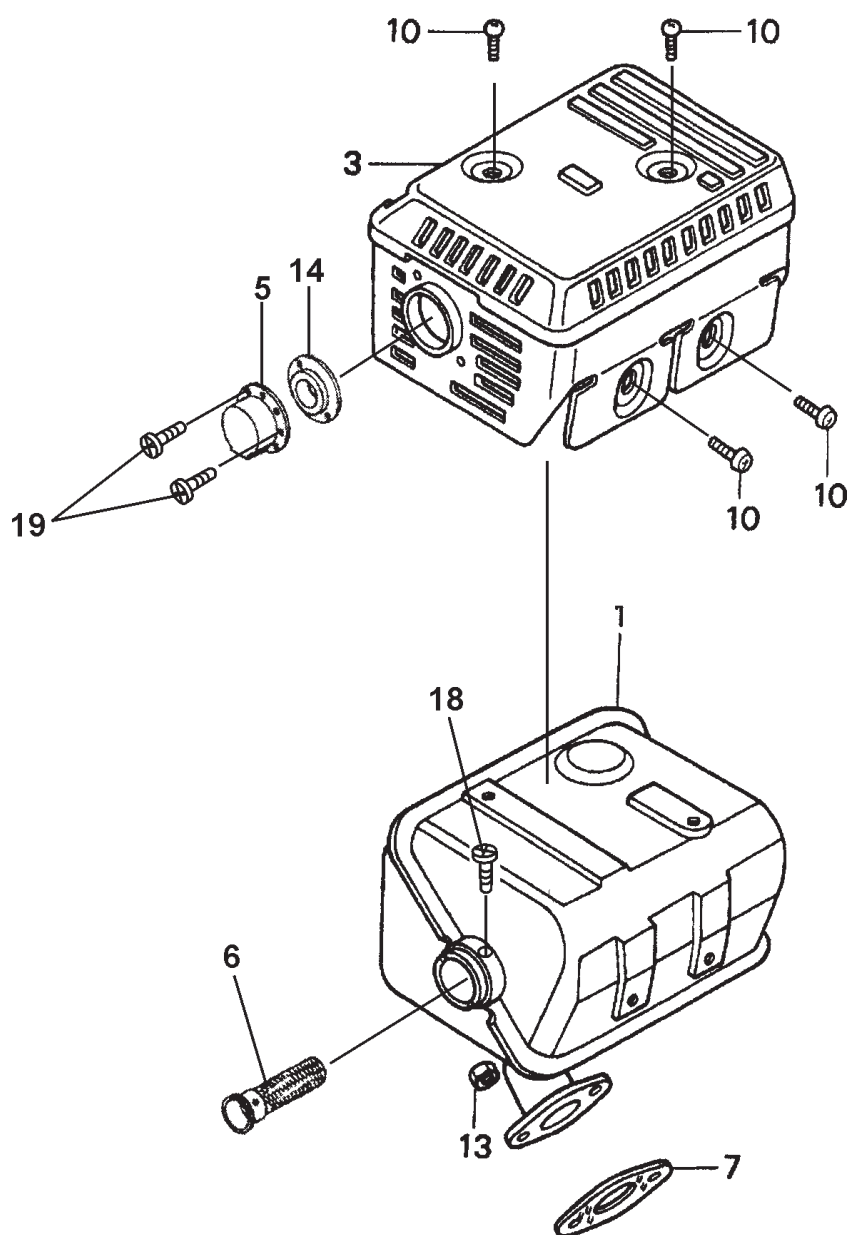

HONDA GX120K1SM12 ENGINE — MUFFLER ASSY.

MUFFLER ASSY.

<u>NO.</u>	<u>PART NO.</u>	<u>PART NAME</u>	<u>QTY.</u>	<u>REMARKS</u>
1	18310ZH8810	MUFFLER, ARRESTER	1	
3	18320ZF1H01	PROTECTOR, MUFFLER	1	
5	18340ZE1010	DEFLECTOR	1	
6	18355ZE1000	ARRESTER, SPARK		
7	18381ZH8800	GASKET, MUFFLER	1	
10	90050ZE1000	SCREW, TAPPING 5X8	4	
13	94001080000S	NUT, HEX. 8MM	2	
14	18522ZE1000	GUIDE, MUFFLER	1	
18	90055ZE1000	SCREW, TAPPING 4X6	1	
19	90002ZG0003	SCREW, TAPPING 4X8	2	

HONDA GX120K1SM12 ENGINE — FUEL TANK ASSY.

FUEL TANK ASSY.

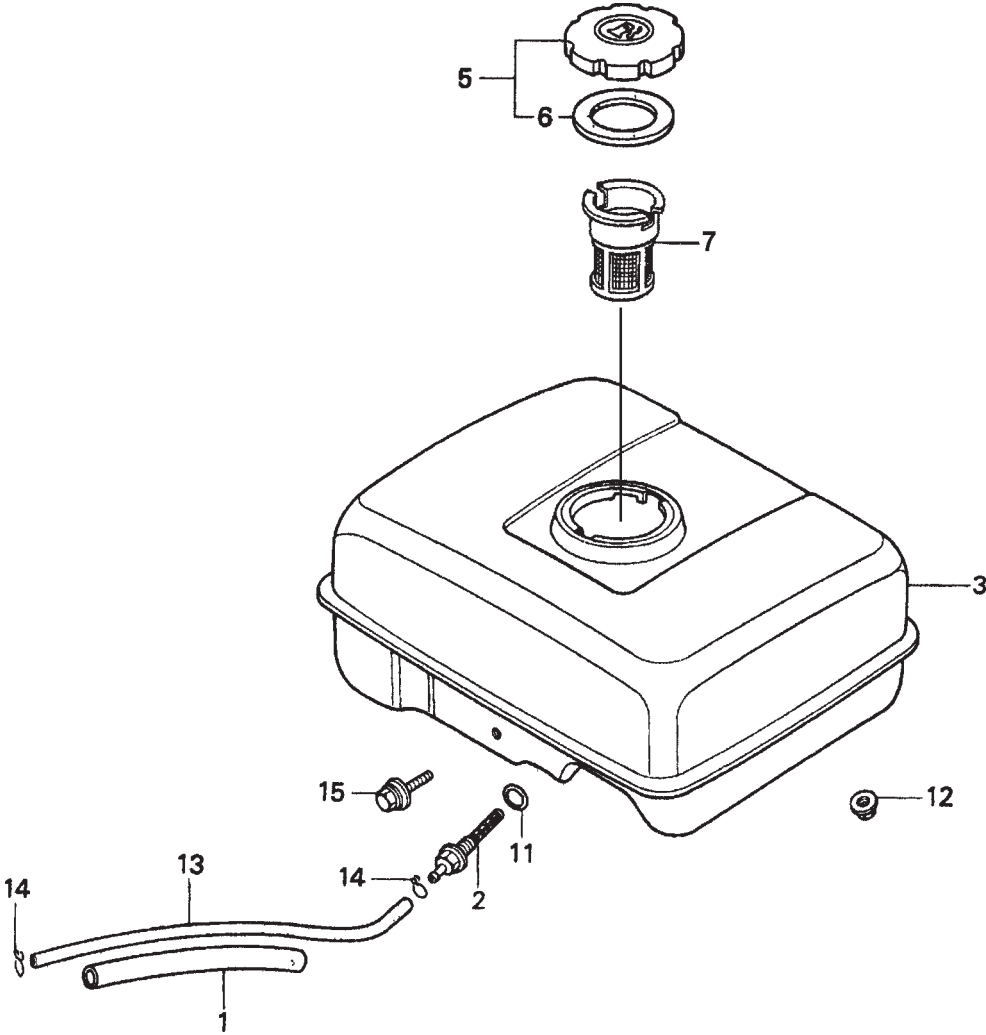

HONDA GX120K1SM12 ENGINE — FUEL TANK ASSY.

FUEL TANK ASSY.

<u>NO.</u>	<u>PART NO.</u>	<u>PART NAME</u>	<u>QTY.</u>	<u>REMARKS</u>
1	16854ZH8000	RUBBER, SUPPORTER 107MM	1	
2	16955ZE1000	JOINT, FUEL TANK	1	
3	17510ZE0020ZD	TANK, FUEL *NH1* (BLACK)	1	
5	17620ZH7023	CAP, FUEL FILLER	1	INCLUDES ITEMS W/*
6*	17631ZH7003	GASKET, FUEL FILLER CAP	1	
7	17672ZE2W01	FUEL FILTER	1	
11	91353671004	O- RING 14MM	1	
12	9405006000	NUT, FLANGE 6MM	2	
13	950014514040	BULK HOSE, FUEL 4.5X140	1	
14	9500202080	CLIP, TUBE (B8)	2	
15	957010602500	BOLT, FLANGE 6X25	1	

HONDA GX120K1SM12 ENGINE — FLYWHEEL ASSY.

FLYWHEEL ASSY.

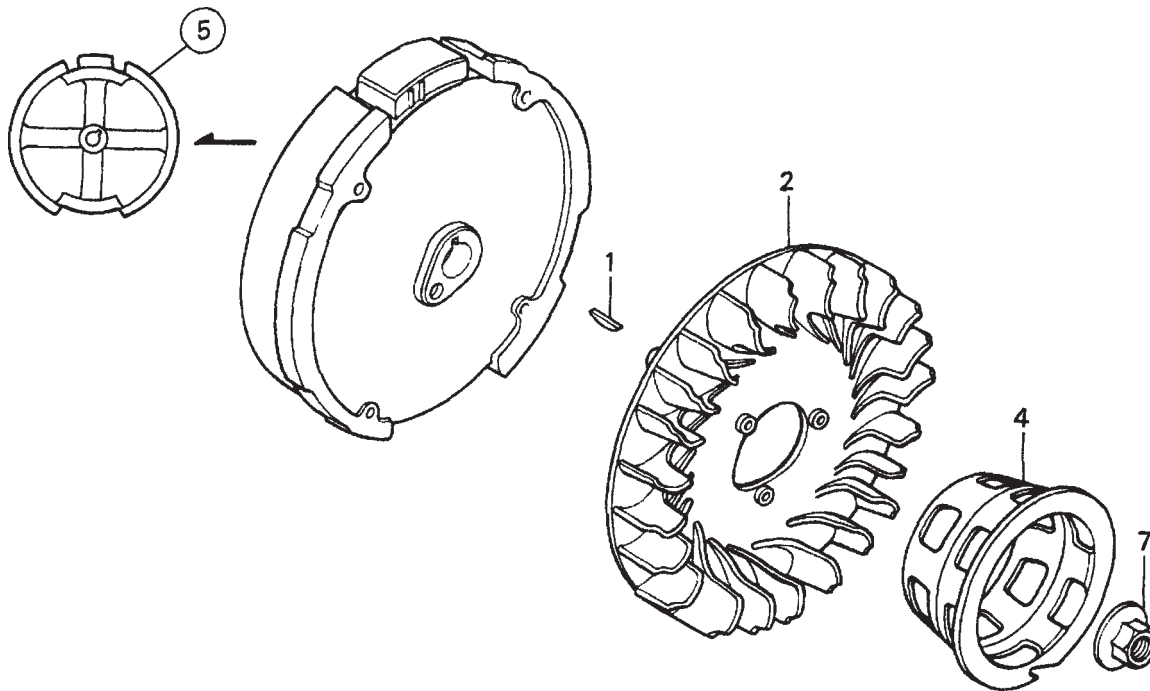

HONDA GX120K1SM12 ENGINE — FLYWHEEL ASSY.

FLYWHEEL ASSY.

<u>NO.</u>	<u>PART NO.</u>	<u>PART NAME</u>	<u>QTY.</u>	<u>REMARKS</u>
1	13331357000	KEY, SPECIAL WOODRUFF 25X18	1	
2	19511ZE0000	FAN, COOLING	1	
4	28451ZH8003	PULLEY, STARTER	1	
5	31100ZE0010	FLYWHEEL	1	
7	90201878003	NUT, SPECIAL 14MM	1	

HONDA GX120K1SM12 ENGINE — IGNITION COIL ASSY.

IGNITION COIL ASSY.

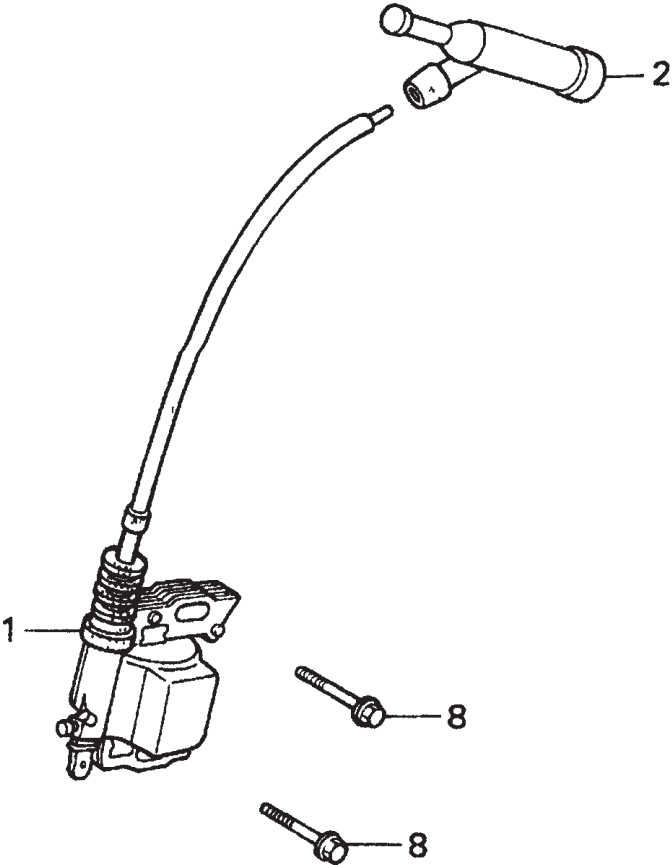

HONDA GX120K1SM12 ENGINE — IGNITION COIL ASSY.

IGNITION COIL ASSY.

<u>NO.</u>	<u>PART NO.</u>	<u>PART NAME</u>	<u>QTY.</u>	<u>REMARKS</u>
1	30500ZE1033	COIL ASSY., IGNITION	1	
2	30700ZE1013	CAP ASSY., NOISE SUPPRESSOR	1	
8	90121952000	BOLT, FLANGE 6X25	2	

HONDA GX120K1SM12 ENGINE — CONTROL ASSY.

CONTROL ASSY.

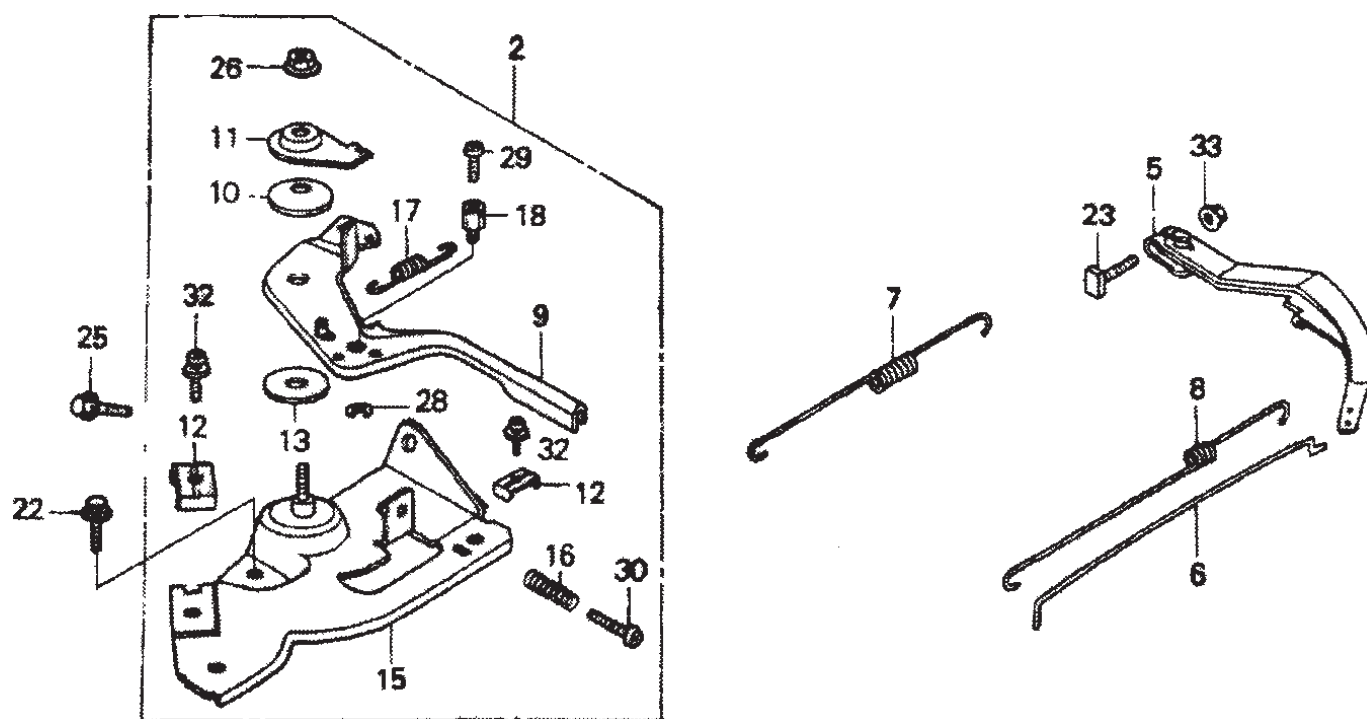

HONDA GX120K1SM12 ENGINE — CONTROL ASSY.

CONTROL ASSY.

<u>NO.</u>	<u>PART NO.</u>	<u>PART NAME</u>	<u>QTY.</u>	<u>REMARKS</u>
2	16500ZH7810	CONTROL ASSY.	1	INCLUDES ITEMS W/#
5	16551ZE0010	ARM, GOVERNOR	1	
6	16555ZE0000	ROD, GOVERNOR	1	
7	16561ZE0020	SPRING, GOVERNOR	1	
8	16562ZE0020	SPRING, THROTTLE RETURN	1	
9#	16571ZH7000	LEVER, CONTROL	1	
10#	16574ZE1000	SPRING, LEVER	1	
11#	16575ZH8000	WASHER, CONTROL LEVER	1	
12#	16576891000	HOLDER, CABLE		
13#	16578ZE1000	SPACER, CONTROL LEVER	1	
15#	16580ZH7810	BASE CONTROL	1	
16#	16584883300	SPRING, CONTROL ADJUSTING	1	
17#	16592ZE1810	SPRING, CABLE RETURN	1	
18#	16594883010	HOLDER, WIRE	1	
22	90013883000	BOLT, FLANGE 6X12 (CT200)	1	
23	90015ZE5010	BOLT, GOVERNOR ARM	1	
25	90022888010	BOLT, FLANGE 6X20 (CT200)	1	
26#	90114SA0000	NUT, SELF- LOCK 6MM	1	
28#	93500040060H	SCREW 4X6	1	
30#	93500050250H	SCREW, PAN 5X25	1	
32#	93500050160A	SCREW, PAN 5X16	1	
33	9405006000	NUT, FLANGE 6MM	1	

HONDA GX120K1SM12 ENGINE — LABELS ASSY.

LABELS ASSY.

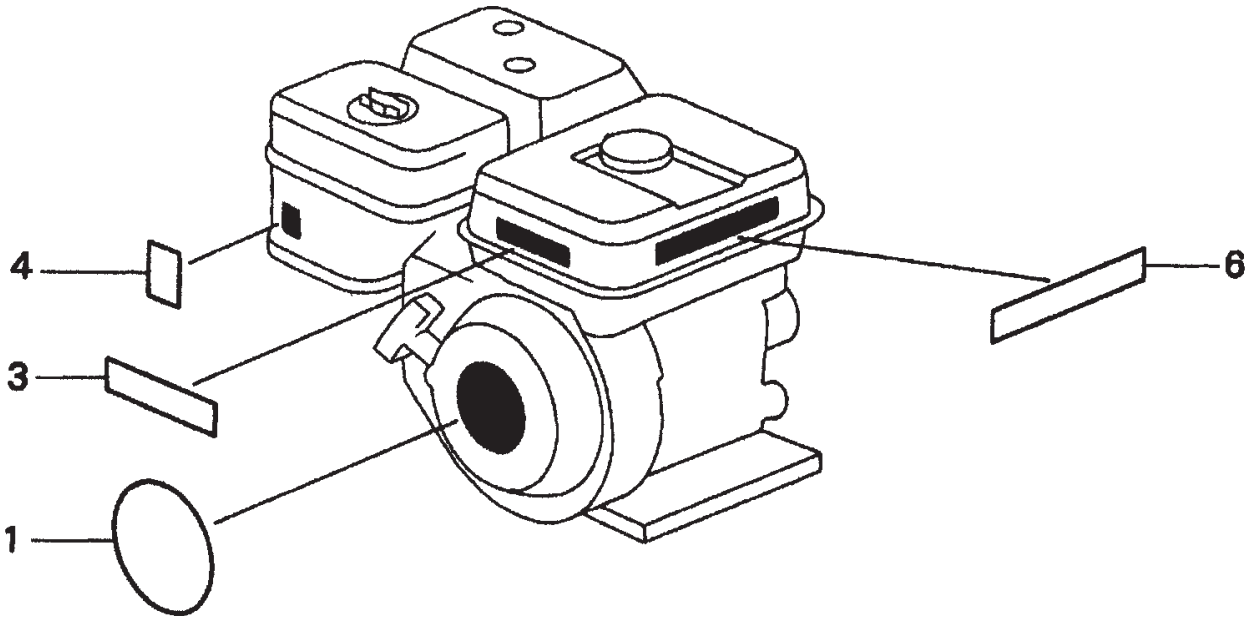

HONDA GX120K1SM12 ENGINE — LABELS ASSY.

LABELS ASSY.

<u>NO.</u>	<u>PART NO.</u>	<u>PART NAME</u>	<u>QTY.</u>	<u>REMARKS</u>
1	87521ZH7020	EMBLEM	1	
3	87522ZH9000	LABEL, CAUTION	1	
4	87528ZE1810	MARK, CHOKE	1	
6	87532ZH8810	MARK, OIL ALERT (E)	1	

PAYMENT TERMS

Terms of payment for parts are net 10 days.

FREIGHT POLICY

All parts orders will be shipped collect or prepaid with the charges added to the invoice. All shipments are F.O.B. point of origin. Multiquip's responsibility ceases when a signed manifest has been obtained from the carrier, and any claim for shortage or damage must be settled between the consignee and the carrier.

MINIMUM ORDER

The minimum charge for orders from Multiquip is \$15.00 net. Customers will be asked for instructions regarding handling of orders not meeting this requirement.

RETURNED GOODS POLICY

Return shipments will be accepted and credit will be allowed, subject to the following provisions:

1. A Returned Material Authorization must be approved by Multiquip prior to shipment.
2. To obtain a Return Material Authorization, a list must be provided to Multiquip Parts Sales that defines item numbers, quantities, and descriptions of the items to be returned.
 - a. The parts numbers and descriptions must match the current parts price list.
 - b. The list must be typed or computer generated.
 - c. The list must state the reason(s) for the return.
 - d. The list must reference the sales order(s) or invoice(s) under which the items were originally purchased.
 - e. The list must include the name and phone number of the person requesting the RMA.
3. A copy of the Return Material Authorization must accompany the return shipment.
4. Freight is at the sender's expense. All parts must be returned freight prepaid to Multiquip's designated receiving point.

5. Parts must be in new and resalable condition, in the original Multiquip package (if any), and with Multiquip part numbers clearly marked.

6. The following items are not returnable:

- a. Obsolete parts. (If an item is in the price book and shows as being replaced by another item, it is obsolete.)
- b. Any parts with a limited shelf life (such as gaskets, seals, "O" rings, and other rubber parts) that were purchased more than six months prior to the return date.
- c. Any line item with an extended dealer net price of less than \$5.00.
- d. Special order items.
- e. Electrical components.
- f. Paint, chemicals, and lubricants.
- g. Decals and paper products.
- h. Items purchased in kits.

7. The sender will be notified of any material received that is not acceptable.

8. Such material will be held for five working days from notification, pending instructions. If a reply is not received within five days, the material will be returned to the sender at his expense.

9. Credit on returned parts will be issued at dealer net price at time of the original purchase, less a 15% restocking charge.

10. In cases where an item is accepted, for which the original purchase document can not be determined, the price will be based on the list price that was effective twelve months prior to the RMA date.

11. Credit issued will be applied to future purchases only.

PRICING AND REBATES

Prices are subject to change without prior notice. Price changes are effective on a specific date and all orders received on or after that date will be billed at the revised price. Rebates for price declines and added charges for price increases will not be made for stock on hand at the time of any price change.

Multiquip reserves the right to quote and sell direct to Government agencies, and to Original Equipment Manufacturer accounts who use our products as integral parts of their own products.

SPECIAL EXPEDITING SERVICE

A \$35.00 surcharge will be added to the invoice for special handling including bus shipments, insured parcel post or in cases where Multiquip must personally deliver the parts to the carrier.

LIMITATIONS OF SELLER'S LIABILITY

Multiquip shall not be liable here under for damages in excess of the purchase price of the item with respect to which damages are claimed, and in no event shall Multiquip be liable for loss of profit or good will or for any other special, consequential or incidental damages.

LIMITATION OF WARRANTIES

No warranties, express or implied, are made in connection with the sale of parts or trade accessories nor as to any engine not manufactured by Multiquip. Such warranties made in connection with the sale of new, complete units are made exclusively by a statement of warranty packaged with such units, and Multiquip neither assumes nor authorizes any person to assume for it any other obligation or liability whatever in connection with the sale of its products. Apart from such written statement of warranty, there are no warranties, express, implied or statutory, which extend beyond the description of the products on the face hereof.

OPERATION & PARTS MANUAL

HERE'S HOW TO GET HELP

PLEASE HAVE THE MODEL AND SERIAL
NUMBER *ON-HAND* WHEN CALLING

MULTIQUIP CORPORATE OFFICE

18910 Wilmington Ave.
Carson, CA 90746
Email: mq@multiquip.com
Internet: www.multiquip.com

800-421-1244
FAX: 310-537-3927

PARTS DEPARTMENT

800-427-1244
310-537-3700

FAX: 800-672-7877
FAX: 310-637-3284

MAYCO PARTS

800-306-2926
310-537-3700

FAX: 800-672-7877
FAX: 310-637-3284

SERVICE DEPARTMENT

800-478-1244
310-537-3700

FAX: 310-537-4259

TECHNICAL ASSISTANCE

800-421-1244

FAX: 310-631-5032

WARRANTY DEPARTMENT

800-421-1244, EXT. 279
310-537-3700, EXT. 279

FAX: 310-537-1173

Your Local Dealer is:



MULTIQUIP INC.

18910 WILMINGTON AVE.
CARSON, CALIFORNIA 90746
800-421-1244 • 310-537-3700
FAX: 310-537-3927

E-mail: mq@multiquip.com

Internet: multiquip.com

Atlanta • Boise • Dallas • Houston • Newark
Montreal, Canada • Manchester, UK
Rio De Janeiro, Brazil • Guadalajara, Mexico