

PARTS MANUAL SUPPLEMENT



P35K, P48K, P54K Shell Kit Mounting Instructions

© COPYRIGHT 2000, MULTIQUIP INC.

Revision #0 (06/08/00)



MULTIQUIP INC.
18910 WILMINGTON AVE.
CARSON, CALIFORNIA 90746
310-537-3700
800-421-1244
FAX: 310-537-3927

PARTS DEPARTMENT:

800-427-1244
FAX: 800-672-7877

SERVICE DEPARTMENT:

800-478-1244
FAX: 310-537-4259

E-mail: mq@multiquip.com • www.multiquip.com

HERE'S HOW TO GET HELP

*PLEASE HAVE THE MODEL AND SERIAL NUMBER
ON-HAND WHEN CALLING*

PARTS DEPARTMENT

800/427-1244 or 310/537-3700

FAX: 800/672-7877 or 310/637-3284

SERVICE DEPARTMENT

800/478-1244 or 310/537-3700

FAX: (310) 537-4259

WARRANTY DEPARTMENT

800/421-1244, EXT. 279 or 310/537-3700

FAX: (310) 537-1173

MAIN

800/421-1244 or 310/537-3700

FAX: (310) 537-3927

Here's how to get help 2
Table of contents 3
Parts ordering procedures 4

Rammax - P35K, P48K, P54K

P35K, P48K, P54K — Parts List 5
Shell Mounting Kit Instructions 6
P35K, P48K, P54K — Shell Kit Drawings 7-19

Terms and conditions of sale — parts 20

*NOTE: Specification and part number
are subject to change without notice.*

PARTS ORDERING PROCEDURES

- Dealer account number
- Dealer name and address
- Shipping address (if different than billing address)
- Return fax number
- Applicable model number
- Quantity, part number and description of each part
- Specify preferred method of shipment:
 - UPS Ground
 - UPS Second Day or Third Day*
 - UPS Next Day*
 - Federal Express Priority One (please provide us with your Federal Express account number)*
 - Airborne Express*
 - Truck or parcel post

**Normally shipped the same day the order is received, if prior to 2PM west coast time.*

Earn Extra Discounts when you order by FAX!

All parts orders which include complete part numbers and are received by fax qualify for the following extra discounts:

<u>Number of line items ordered</u>	<u>Additional Discount</u>
1-9 items	3%
10+ items**	5%

Get special freight allowances when you order 10 or more line items via FAX!**

- UPS Ground Service at no charge for freight
- PS Third Day Service at one-half of actual freight cost

No other allowances on freight shipped by any other carrier.

**Common nuts, bolts and washers (all items under \$1.00 list price) do not count towards the 10+ line items.

DISCOUNTS ARE SUBJECT TO CHANGE

Fax order discount and UPS special programs revised June 1, 1995

**Extra Fax Discount
for Domestic USA
Dealers Only**

**Up to 5%
extra savings!**

**UPS
Special**
For faxed orders only

**Now! Direct TOLL-FREE access
to our Parts Department!**

Toll-free nationwide:

800-421-1244

Toll-free FAX:

800/6-PARTS-7 • 800-672-7877

Prior to installation, please insure that you have received all parts. Each kit consists of the following:

Model: P35K

- (1)..... BM 236 Center Punch
- (1)..... 56334 Lifting eye bolt
- (3)..... 08454 Smooth Drum Segments
- (18).... 58032 Flat washer B21 DIN 125
- (18).... 55393 Hex bolt M20 x 50 DIN 933-10.9
- (1)..... 16037 Front scraper (assembled)
- (1)..... 16036 Back scraper (assembled)
- (18).... 59654 Headless pin M20 x 20 DIN 913

Model: P48K

- (1)..... BM 236 Center Punch
- (1)..... 56334 Lifting eye bolt
- (3)..... 08605 Smooth Drum Segments
- (18).... 58032 Flat washer
- (18).... 55393 Hex bolt M20 x 50 DIN 933-10.9
- (1)..... 16037 Front scraper (assembled)
- (1)..... 16036 Back scraper (assembled)
- (18).... 59654 Headless pin M20 x 20 DIN 913

Model: P 54K

- (1)..... 56334 Lifting bolt
- (1)..... BM236 Center punches
- (3)..... 07846 Shell Segments
- (2)..... Scrapper bars (assembled)
- (2)..... Scrapper Mounting Brackets
- (18)..... Washers B23
- (18)..... Hex head bolts M22 x 50
- (1)..... Set of Installation instructions

Should any of these listed parts be missing, please contact us. Note: the Center punches will only be needed, if your drum is not factory predrilled.

P35K, P48K, P54K — SHELL KIT MOUNTING INSTRUCTIONS

Mounting of smooth drum segments

If this is the first time you install the shell kit and your sheep foot drum has not been pre-drilled, some additional steps will be required prior to installing the smooth drum segments. These preparatory steps are outlined first. If you re-install the shell kit or your drum has been factory pre-drilled, skip Step 1 and go straight to Step 2 “Installation of Segments”.

Should you require any help, please do not hesitate to call on us.

STEP 1 Pre-drill sheep foot drum

The individual segments are marked with the following numbers 1, 2 and 3.

On the right hand side of each segment additional notches are stamped in which do have the form of a center punch. Line up the segments to mount and ensure, these center punches are all facing the same side.

In the center of each smooth drum segment is a hex bolt welded, in which the enclosed lifting eye can be screwed in, in order to facilitate the mounting of the parts.

To mark the drilling locations for the mounting holes, use the supplied punches. Screw the punches into each of the segments mounting studs, working with one segment at a time. Position segment 1 on the sheep foot drum, align it and secure it by using screw clamps. Using a hammer, mark the drilling locations on the sheep foot drum.

Drill the drum as marked and screw on segment 1.

Repeat these steps for each of the segments, until all 3 segments are mounted. Depending on wear of the drum at time of first installation, a 2mm to 6 mm gap between segments is normal.

STEP 2 Installation of the shell kits

If your sheep foot drum has been factory pre-drilled,

locate Segment 1 and align it on the drum. Secure it with screw clamps. Screw in the bolts (M22 x 50) placing a washer on the bolt head.

Locate Segment 2. Align this segment to the first. Secure with screw clamps. Depending on how much the drum has worn a gap of 2mm to 6 mm is normal. Any gap between segments should be the same. Install the bolts.

Repeat these steps for segment three.

Mount the scrapers in front and back of the smooth drum segments. The scrapers must be aligned to have a gap of 5 to 10 mm (.196 in. to .393 in)

Finally, the center nut used to install the eyelet to initially lift the segment 1 into position should be removed. Simply tap the nut with a hammer to break the weld.

Your shell kit is now ready to use.

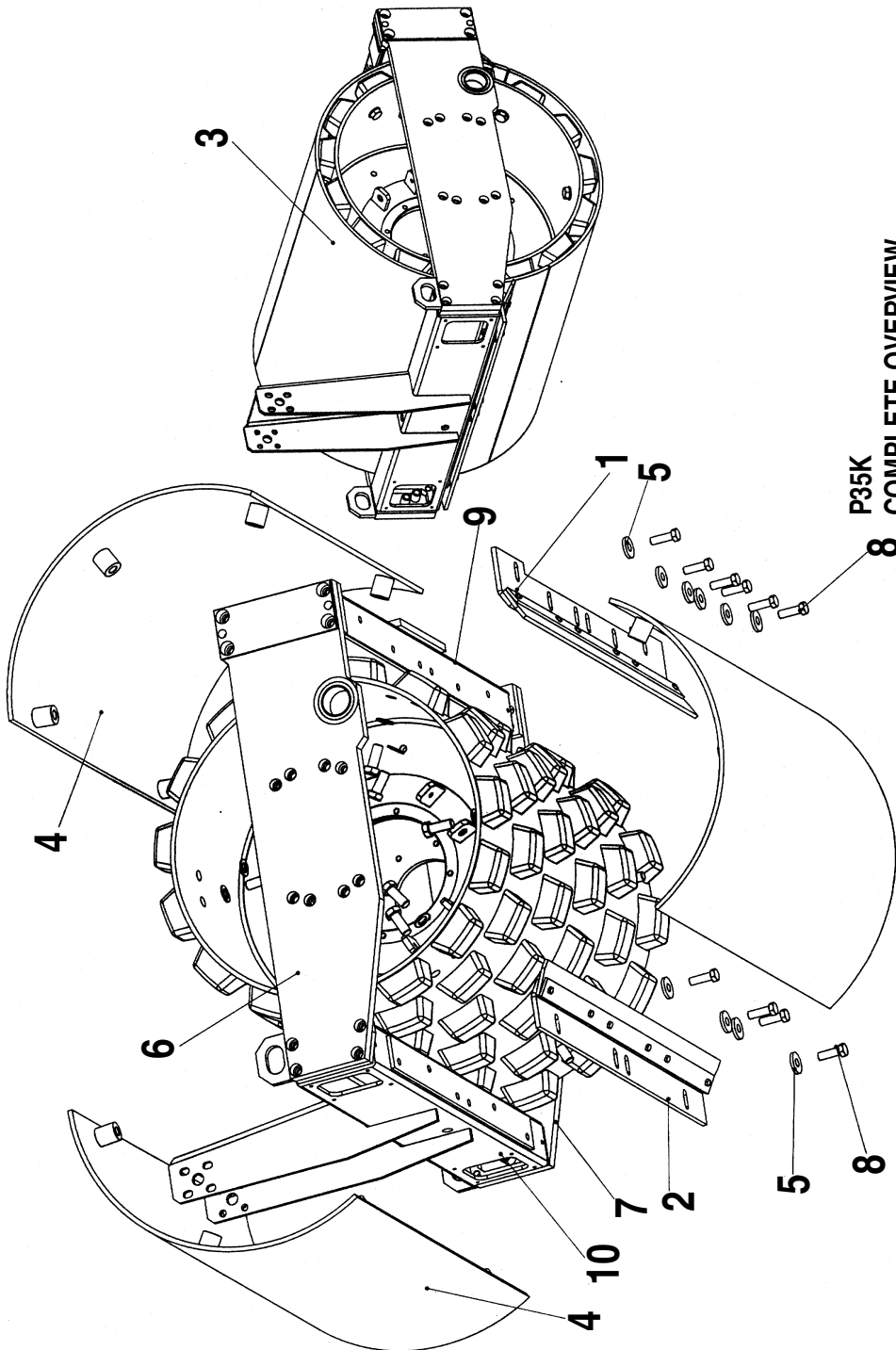

P35K COMPLETE OVERVIEW

1) Scraper Complete, Back	P/N 16036	Qty 1
2) Scraper Complete, Front	P/N 16037	Qty 1
3) Smooth Drum Segment Kit Complete ...	P/N 16052	Qty 1
4) Smooth Drum Segments	P/N 08454	Qty 3
5) Flat Washer A17 ST DIN 6340	P/N 58129	Qty 10
6) Left Side Plate Complete	P/N 08437	Qty 1
7) Right Side Plate Complete	P/N 08436	Qty 1
8) Hex bolt M16 x 50 DIN 933-8.8	P/N 55963	Qty 10
9) Cross Section, Back	P/N 08438	Qty 1
10) Cross Section, Front	P/N 08249	Qty 1

**P35K
SEGMENTS SECTION**

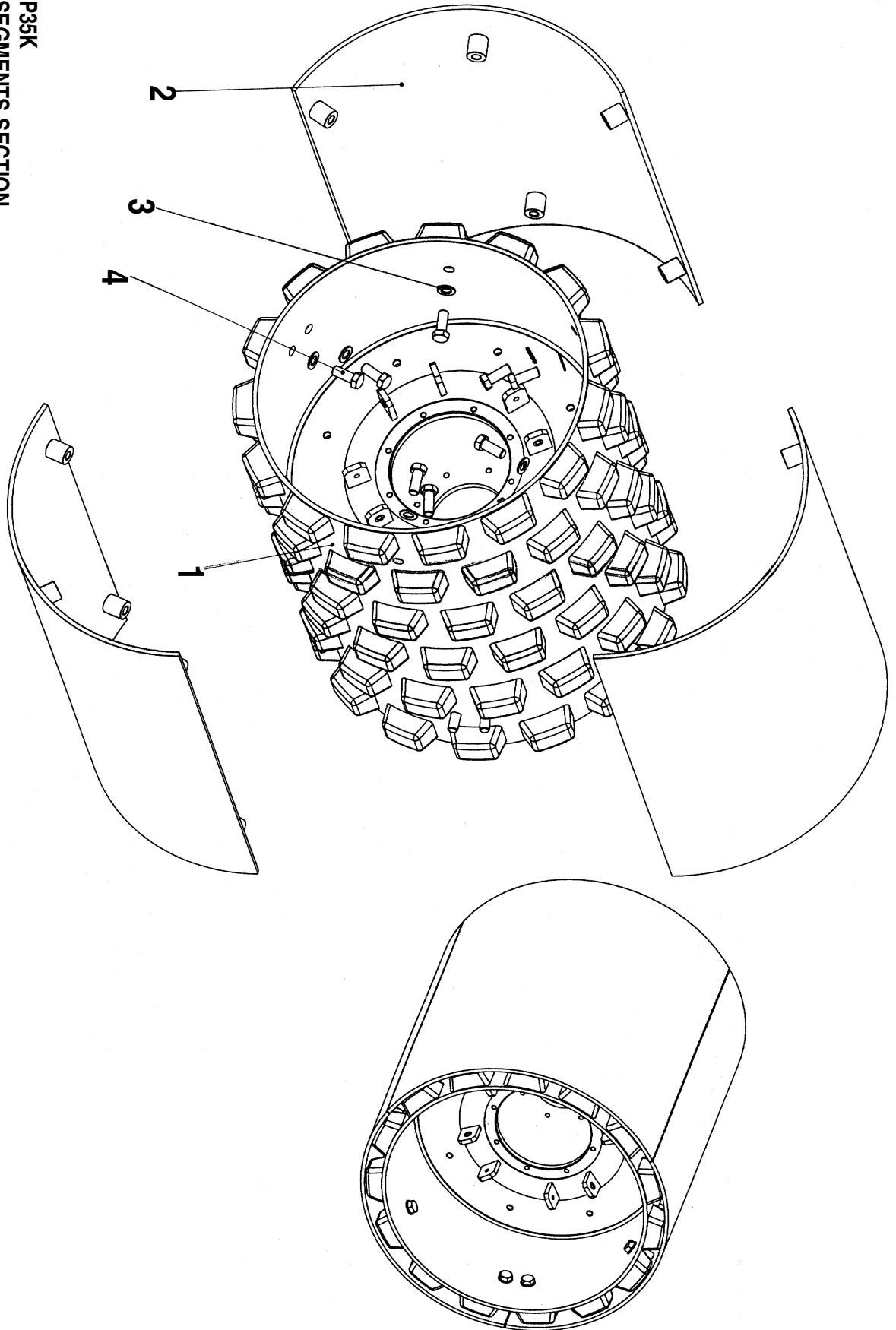

- | | | |
|---|-----------|--------|
| 1) Sheeps Foot Drum Complete | P/N 08458 | Qty 1 |
| 2) Smooth Drum Segments | P/N 08454 | Qty 3 |
| 3) Flat Washer B21 DIN 125 | P/N 58032 | Qty 18 |
| 4) Hex Bolt M20 x 50 DIN 933-10.9 | P/N 55393 | Qty 18 |

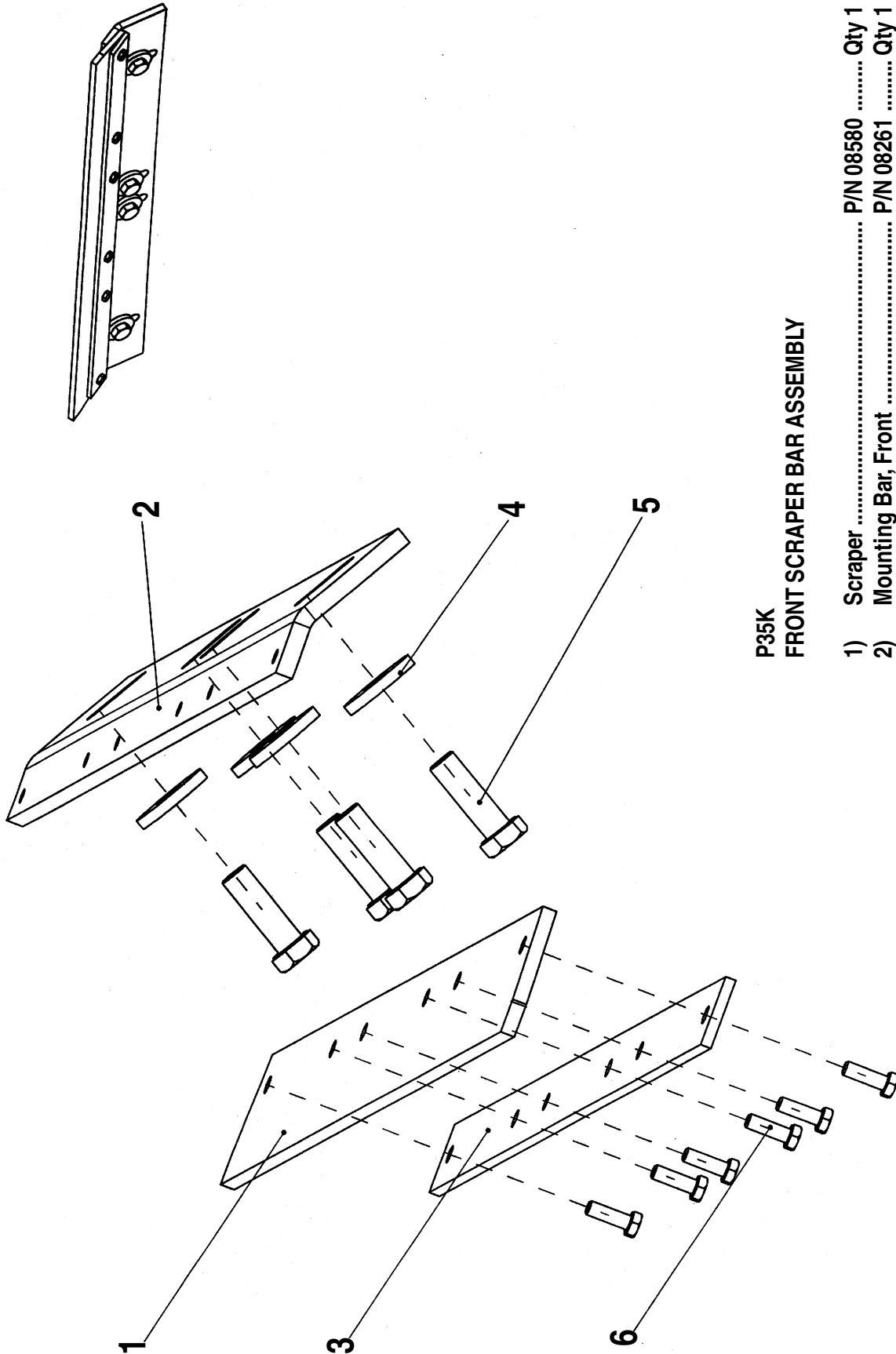

**P35K
FRONT SCRAPER BAR ASSEMBLY**

- | | | |
|--|-----------------|-------|
| 1) Scraper | P/N 08580 | Qty 1 |
| 2) Mounting Bar, Front | P/N 08261 | Qty 1 |
| 3) Mounting Support, Front | P/N 08163 | Qty 1 |
| 4) Flat Washer A17 ST DIN 6340 | P/N 58129 | Qty 4 |
| 5) Hex Bolt M16 x 50 DIN 933.8.8 | P/N 55963 | Qty 4 |
| 6) Hex Bolt M8 x 25 DIN 933 | P/N 55903 | Qty 6 |

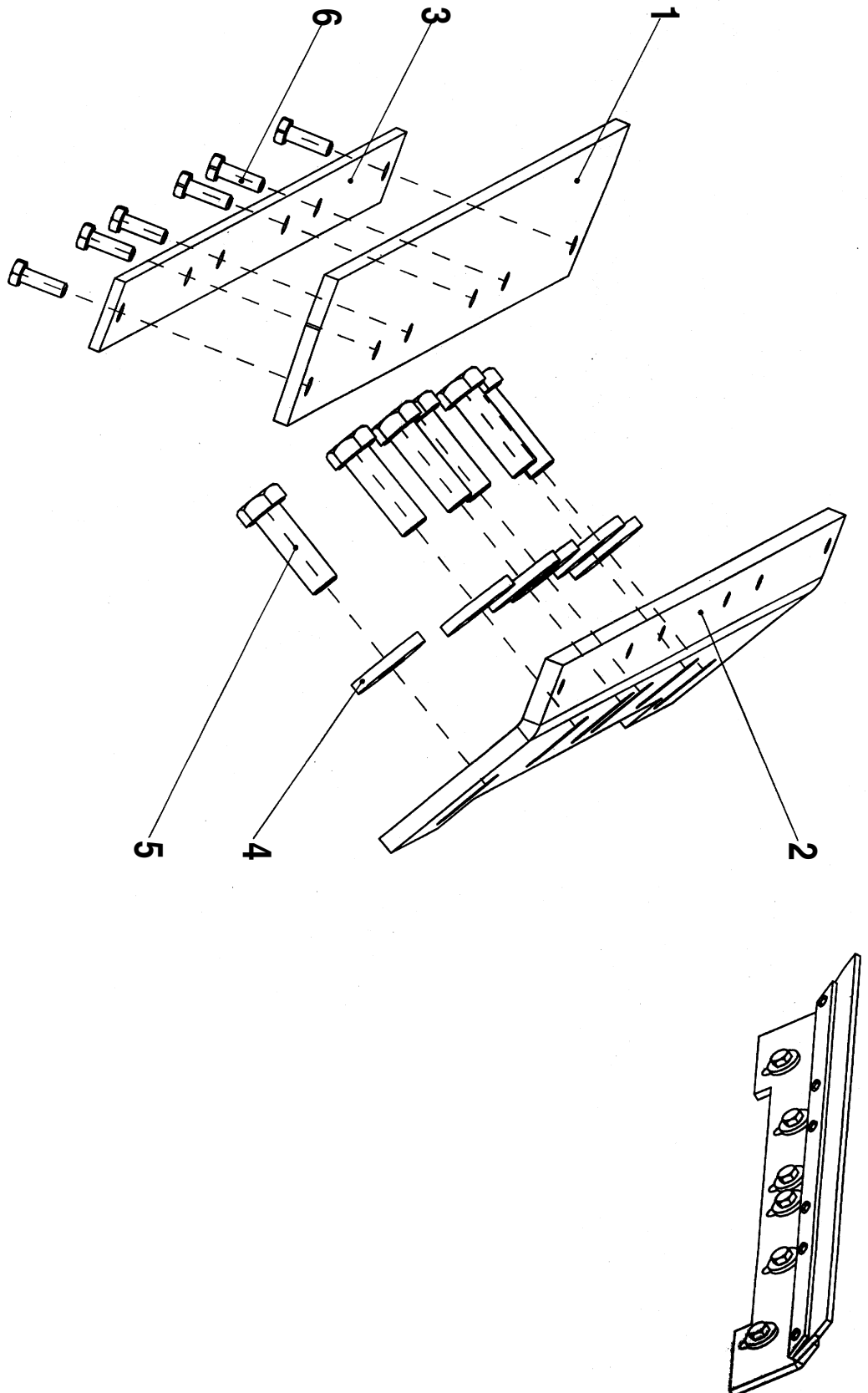

**P35K
REAR SCRAPER-BAR ASSEMBLY**

- | | | |
|---------------------------------------|-----------------|-------|
| 1) Scraper — Back Side | P/N 08581 | Qty 1 |
| 2) Mounting-Bar — Back | P/N 08167 | Qty 1 |
| 3) Mounting Support — Back | P/N 08163 | Qty 1 |
| 4) Flat Washer A17 DIN 6340 | P/N 58129 | Qty 6 |
| 5) Hex Bolt M16 x 50 DIN 933.88 | P/N 55963 | Qty 6 |
| 6) Hex Bolt M8 x 25 DIN 933 | P/N 55903 | Qty 6 |

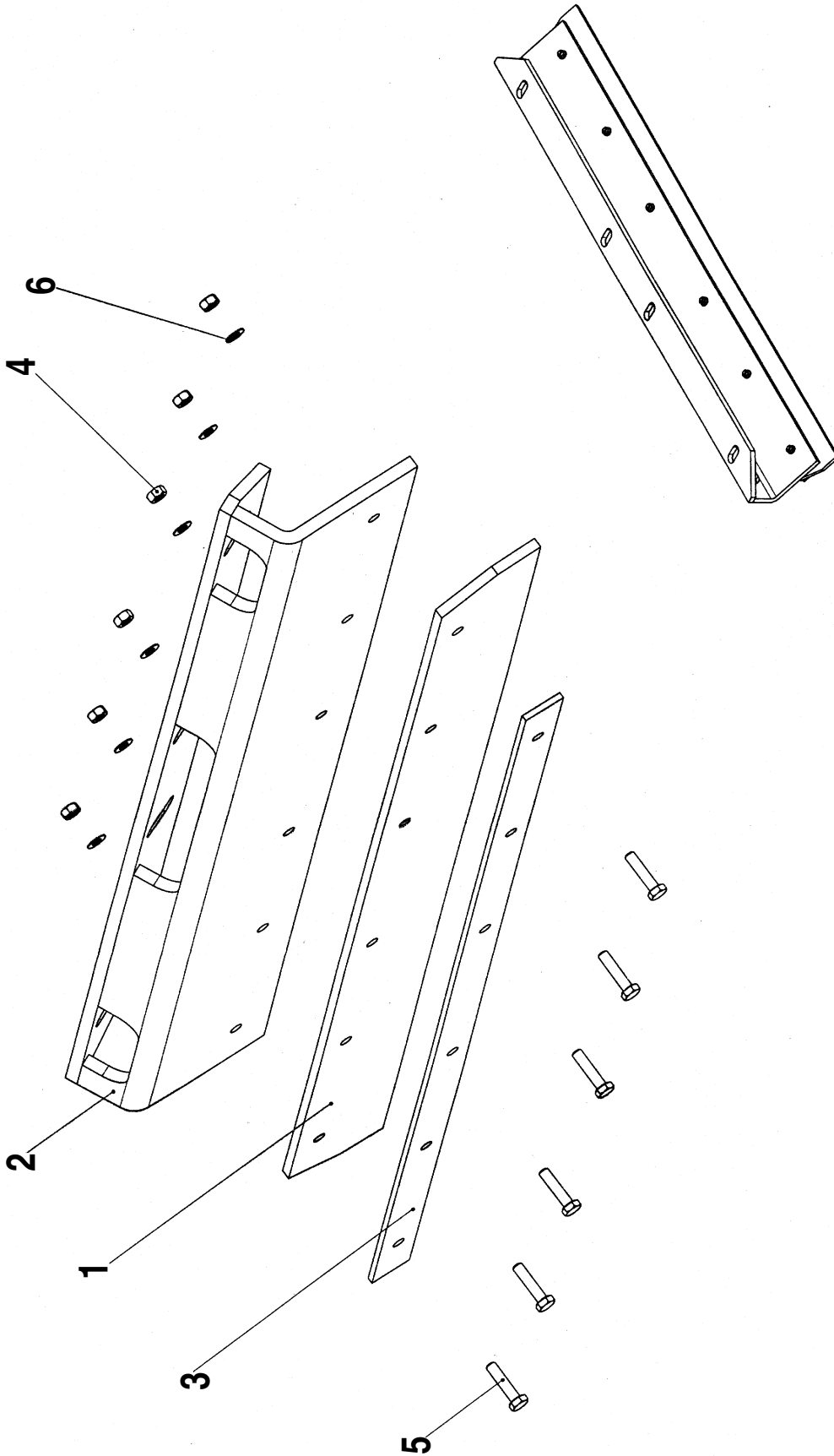

**P48K
FRONT SCRAPER BAR ASSEMBLY**

1) Scraper	P/N 08559	Qty 1
2) Mounting Bar, Front	P/N 08562	Qty 1
3) Mounting Support	P/N 08561	Qty 1
4) Hex Nut M8 DIN 934-8	P/N 57029	Qty 6
5) Hex Bolt M8 x 35 DIN 933.8.8	P/N 55908	Qty 6
6) Disk Spring A16 x 8.2 x 0.9 DIN 2093	P/N 59057	Qty 6

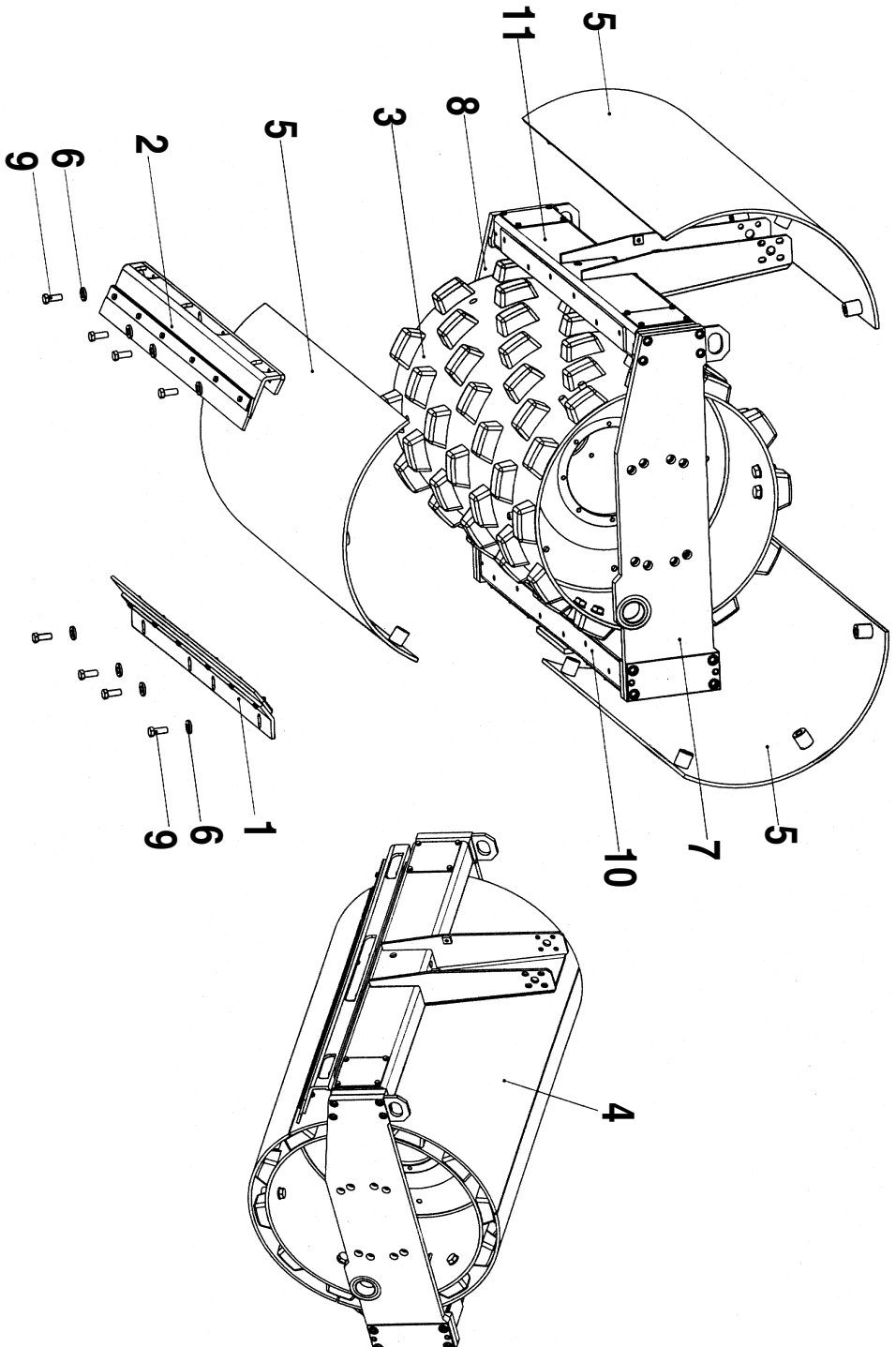

**P48K
COMPLETE OVERVIEW**

- | | | |
|--|-----------|-------|
| 1) Scraper Set Complete, Back | P/N 16006 | Qty 1 |
| 2) Scraper Set Complete, Front | P/N 16003 | Qty 1 |
| 3) Sheep Foot Drum | P/N 08608 | Qty 1 |
| 4) Smooth Drum Segment Kit | P/N 16039 | Qty 1 |
| 5) Smooth Drum Segments | P/N 08605 | Qty 3 |
| 6) Washer | P/N 08276 | Qty 8 |
| 7) Left Side Plate Complete | P/N 08491 | Qty 1 |
| 8) Right Side Plate Complete | P/N 18496 | Qty 1 |
| 9) Hex Bolt M16 x 40 DIN 933-8.8 | P/N 55938 | Qty 8 |
| 10) Cross Section, Back | P/N 08498 | Qty 1 |
| 11) Cross Section, Front | P/N 08493 | Qty 1 |

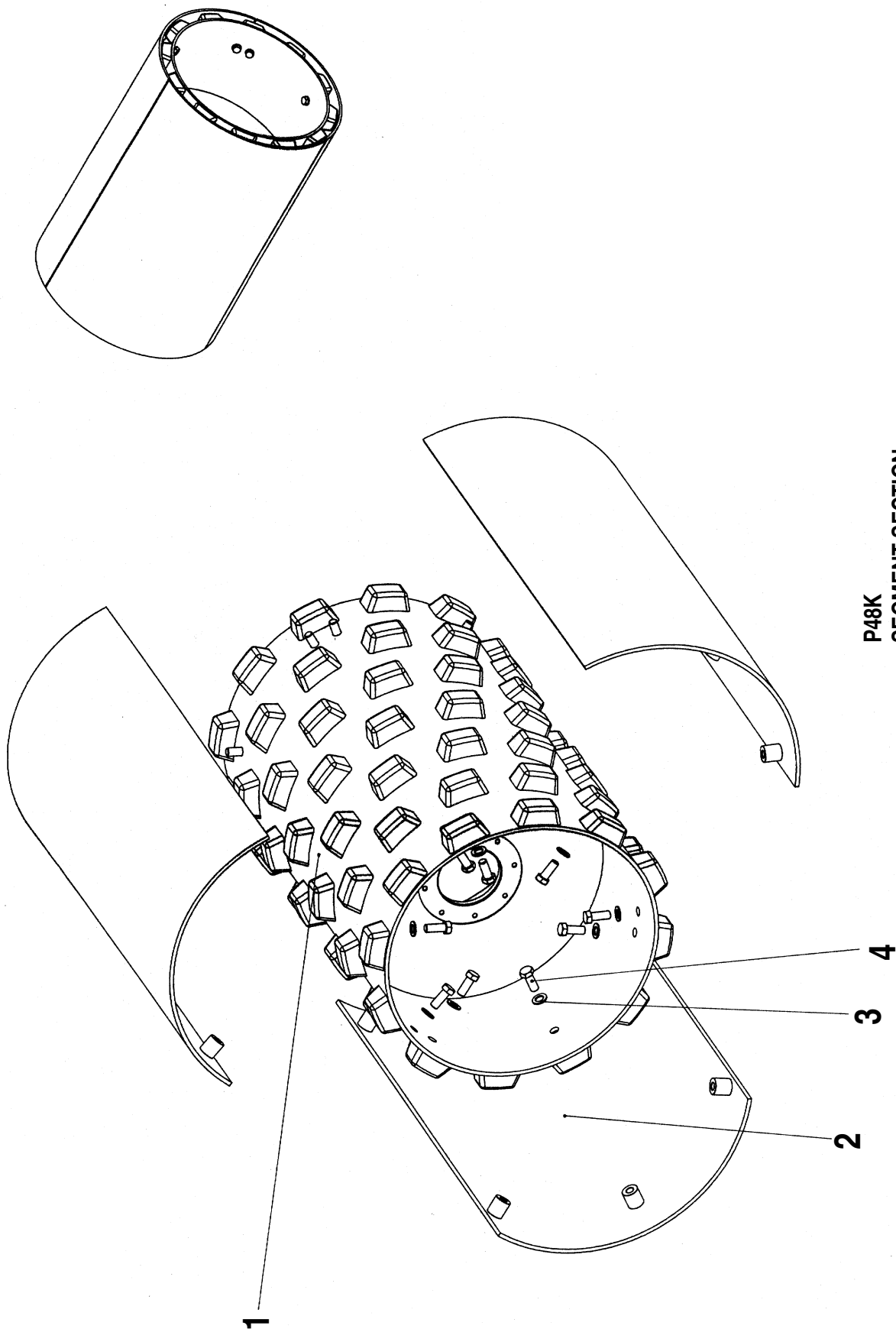

**P48K
SEGMENT SECTION**

- 1) Drum P/N 08608 Qty 1
- 2) Smooth Drum Segment P/N 08605 Qty 3
- 3) Flat Washer B21 DIN 125 P/N 58032 Qty 18
- 4) Hex Head Bolt P/N 55393 Qty 18

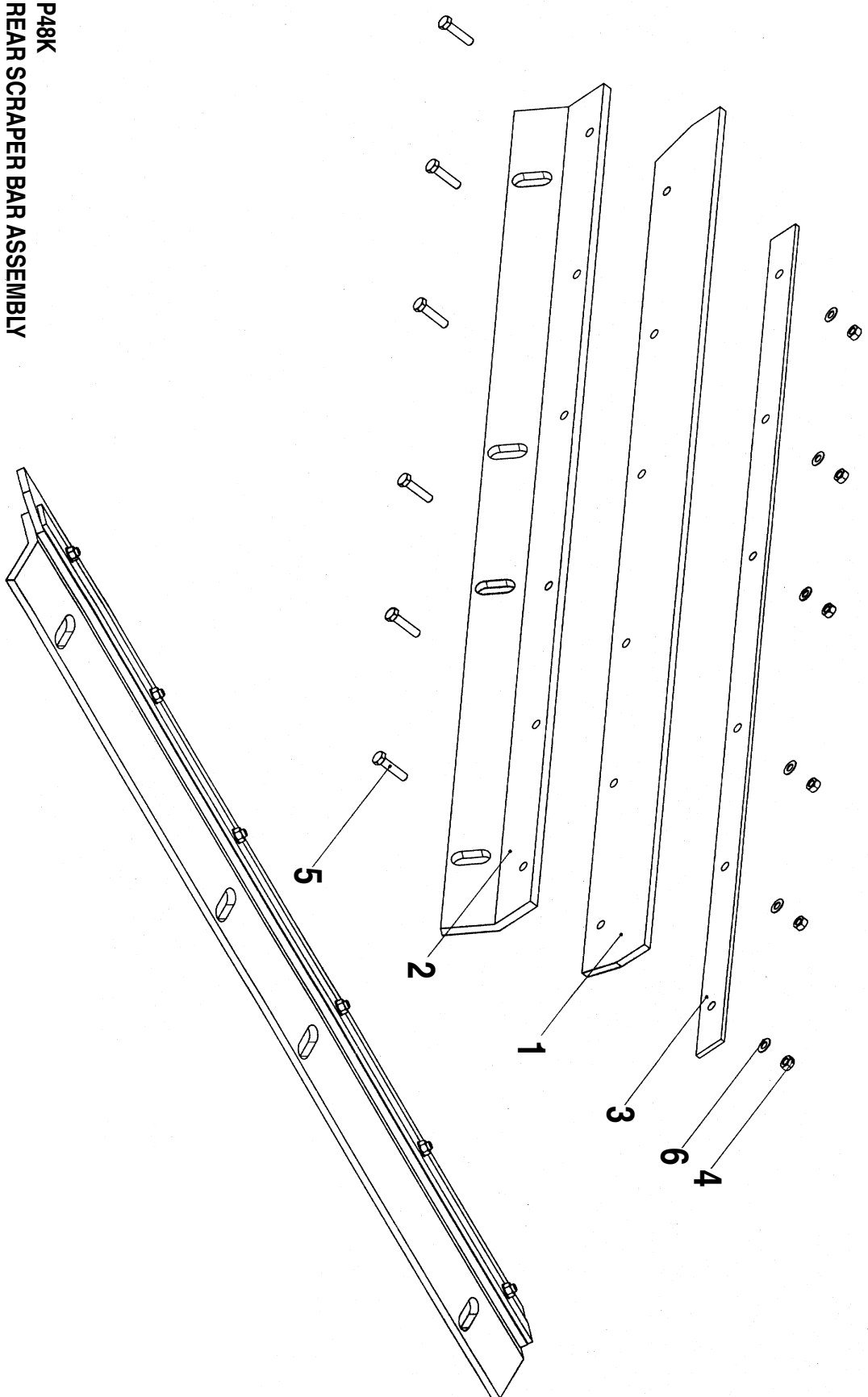

**P48K
REAR SCRAPER BAR ASSEMBLY**

- | | | |
|---|-----------------|-------|
| 1) Scraper | P/N 08559 | Qty 1 |
| 2) Mounting Bar, Rear | P/N 08560 | Qty 1 |
| 3) Mounting Support | P/N 08561 | Qty 1 |
| 4) Hex Nut M8 DIN 934-8 | P/N 57029 | Qty 6 |
| 5) Hex Bolt M8 x 35 DIN 933 8.8 | P/N 55908 | Qty 6 |
| 6) Disk Spring A16 x 8.2 x 0.9 DIN 2093 | P/N 59057 | Qty 6 |

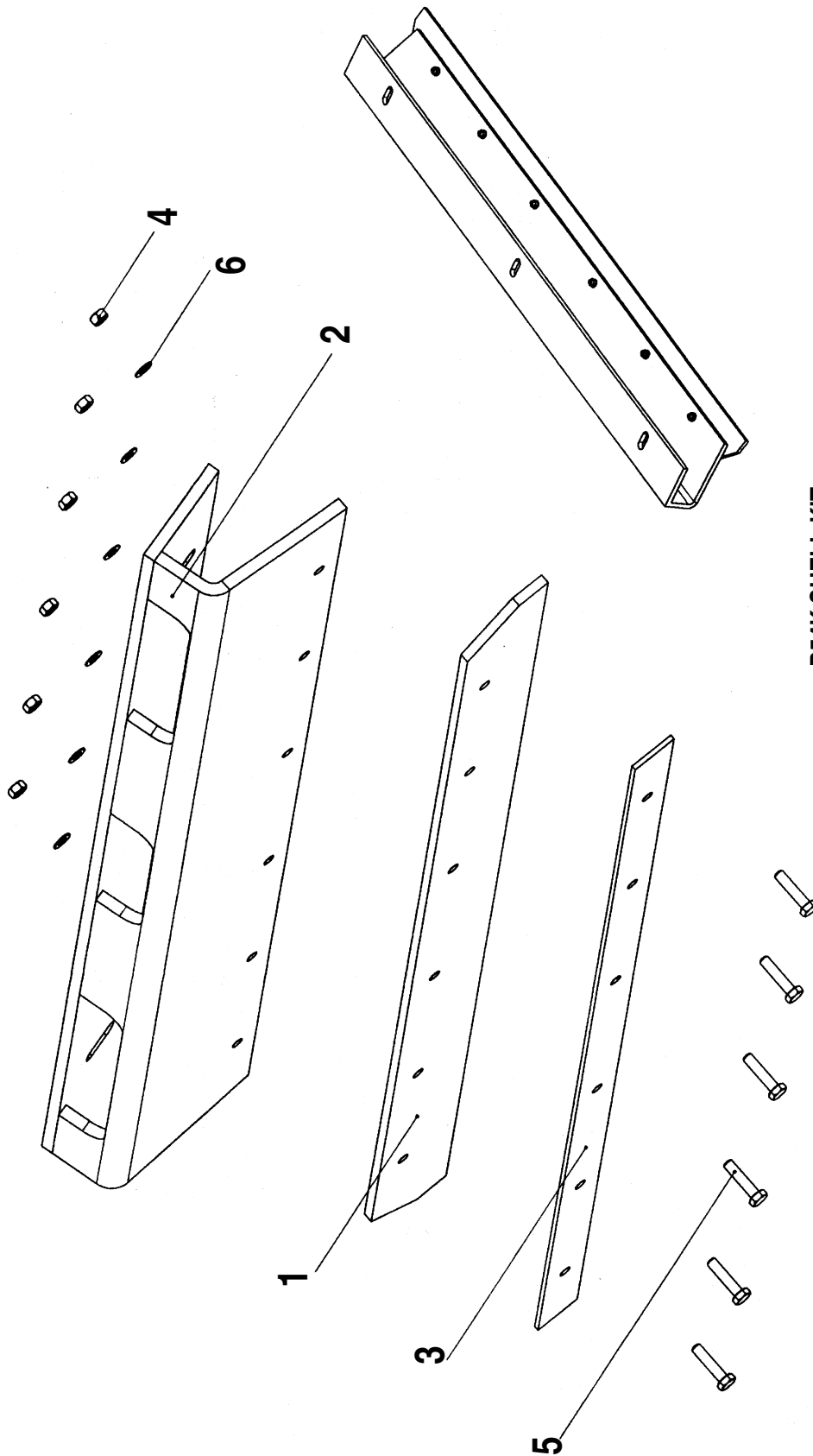

**P54K SHELL KIT
BACK SCRAPER BAR ASSEMBLY**

- 1) Scraper P/N 07845 Qty 1
- 2) Back mounting bracket P/N 07848 Qty 1
- 3) Mounting Bar P/N 07829 Qty 1
- 4) Hex Nut M8 P/N DIN 934-8 Qty 6
- 5) Hex Bolt M8 x 35mm P/N DIN 933-8.8 Qty 6
- 6) Washer A16 x 8.2 x 0.9 P/N DIN 2093 Qty 6

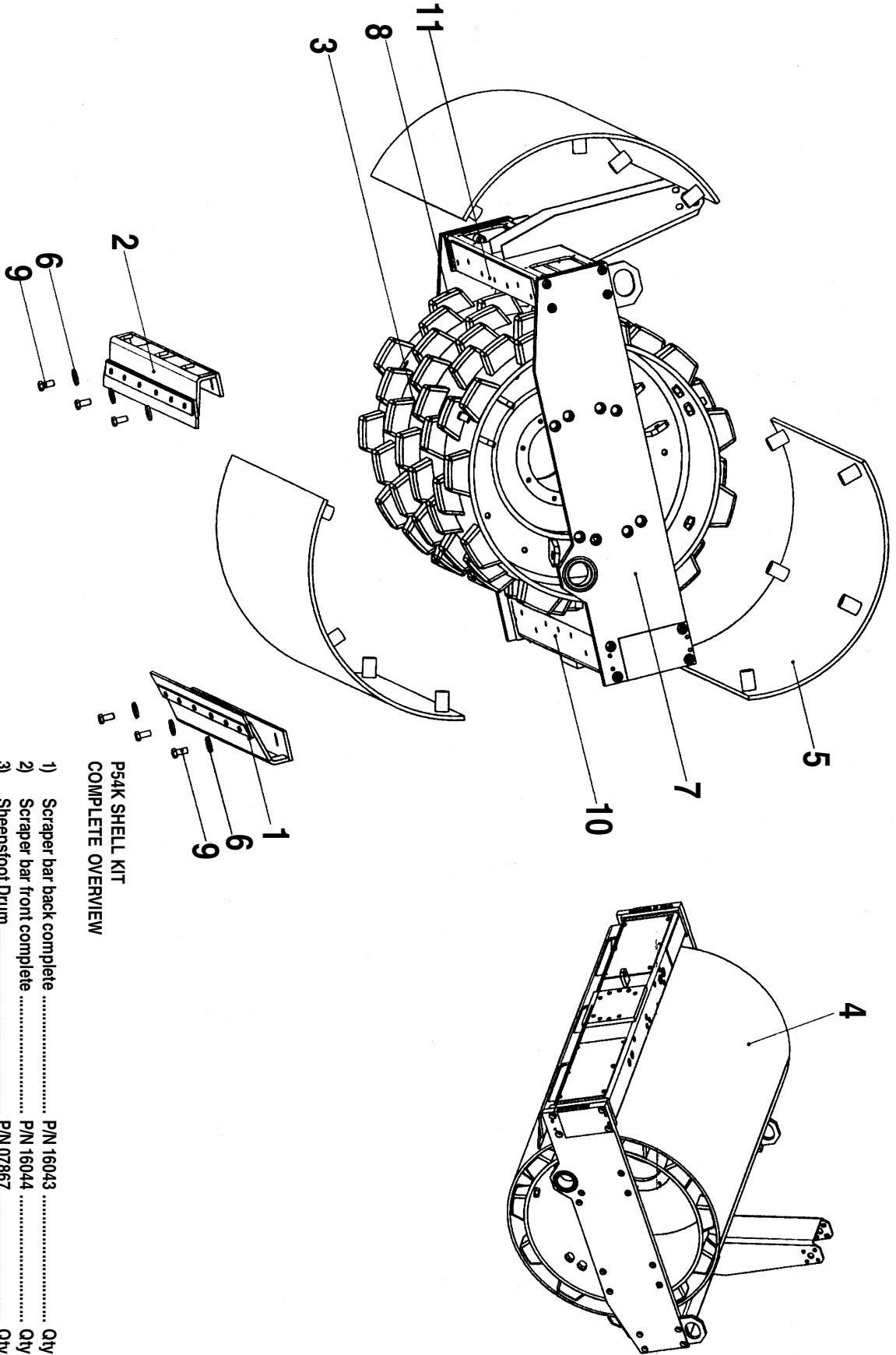

**P54K SHELL KIT
COMPLETE OVERVIEW**

1) Scraper bar back complete	P/N 16043	Qty 1
2) Scraper bar front complete	P/N 16044	Qty 1
3) Sheepfoot Drum	P/N 07867	Qty 1
4) Shell Kit Complete (Installed)	P/N 16012	Qty 1
5) Shell Segments	P/N 07846	Qty 3
6) Washer A17	P/N DIN 6340	Qty 10
7) Side Plate Left Complete	P/N DIN 07870	Qty 1
8) Side Plate right Complete	P/N DIN 07871	Qty 1
9) Hex head Bolt M16 x 35	P/N DIN 933-8.8	Qty 10
10) Back cross piece	P/N 07834	Qty 1
11) Front cross piece	P/N 07830	Qty 1

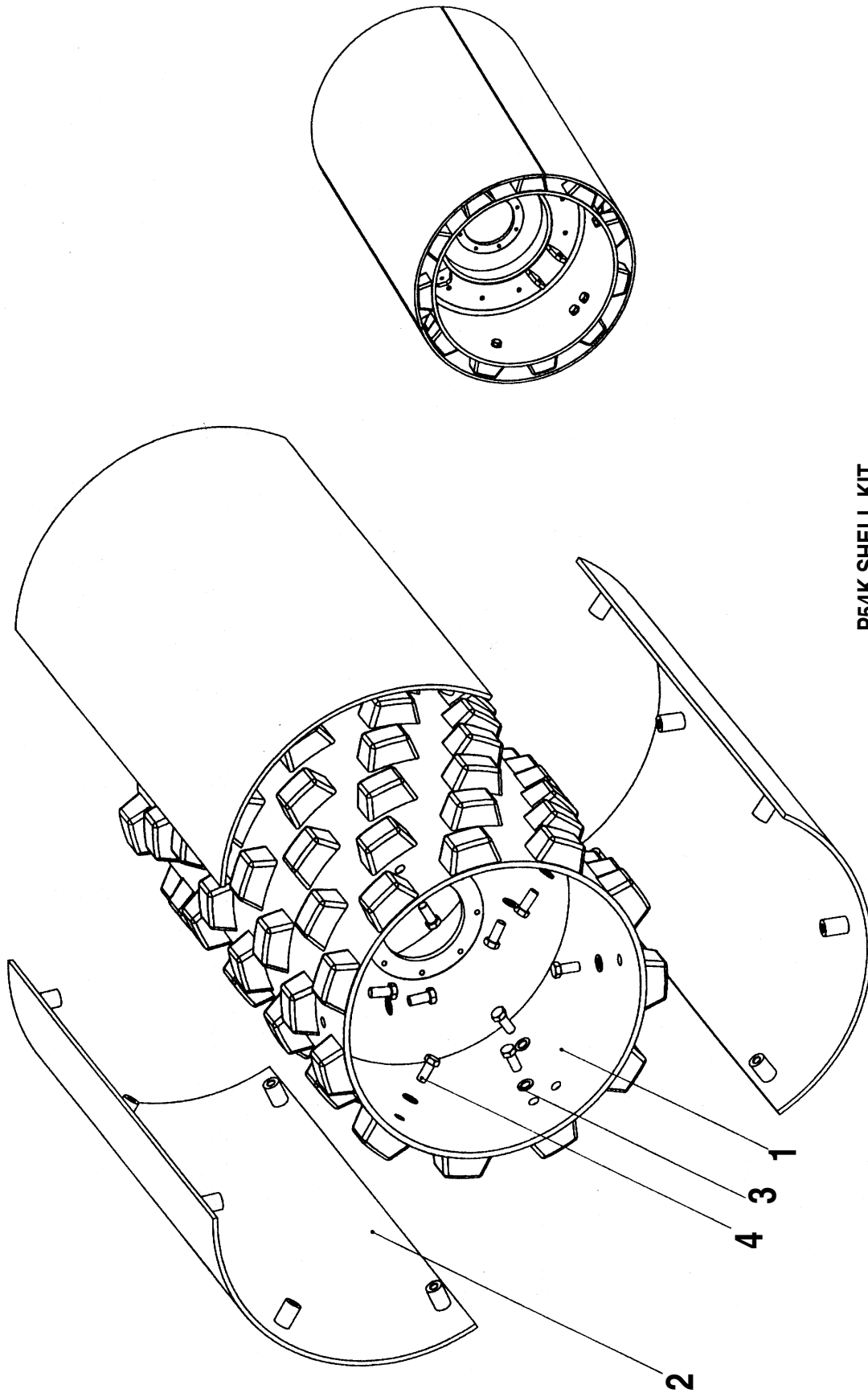

**P54K SHELL KIT
SEGMENTS SECTION**

- 1) Sheepfoot Drum P/N 07867 Qty 1
- 2) Shell Segment P/N 07846 Qty 3
- 3) Washer B23 P/N DIN 125 Qty 18
- 4) Hex Headbolt M22 x 50 P/N DIN 933-10.9 Qty 18

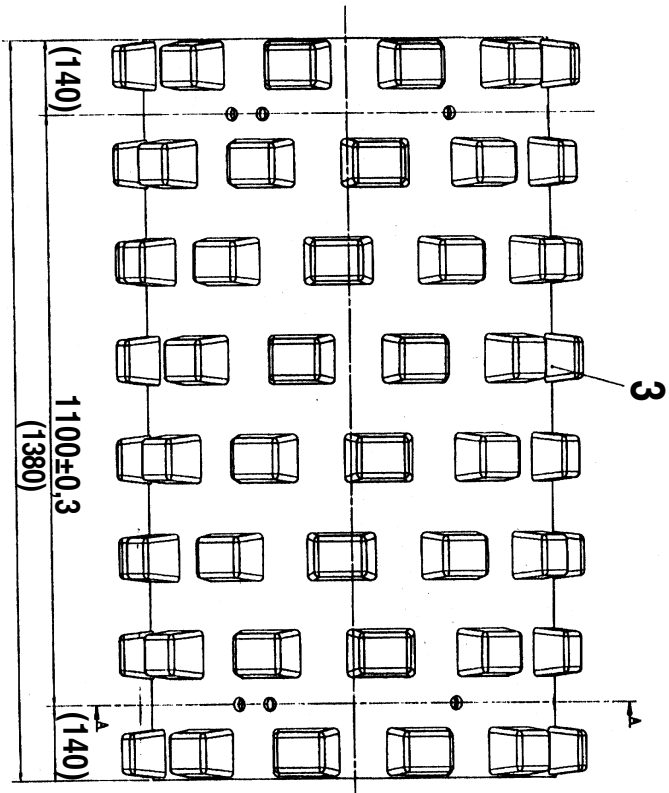
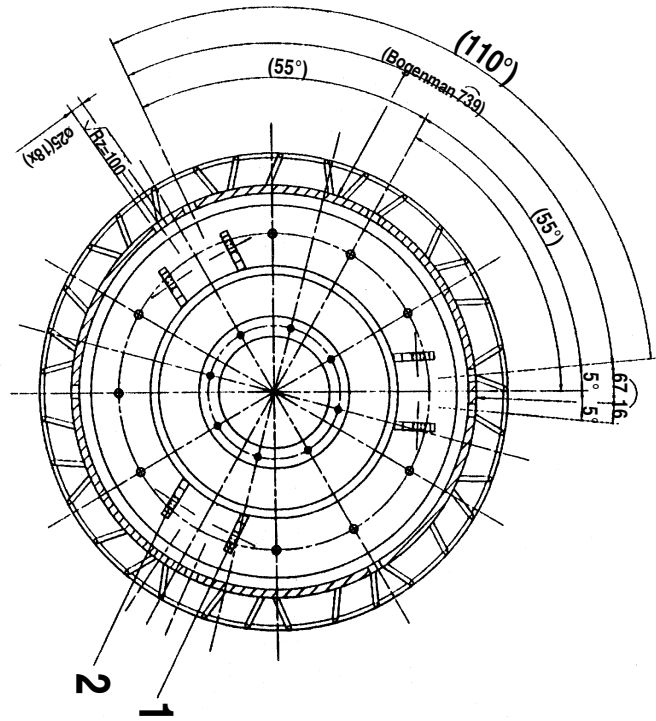
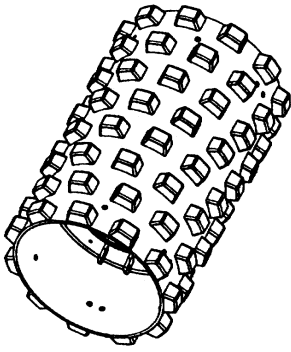

**P54K SHEEPSFOOT DRUM
MOUNTING HOLE POSITIONS**

- 1) Mounting Plate P/N 07738 Qty 3
- 2) Mounting Plate P/N 07739 Qty 3
- 3) Sheepfoot segments P/N 07081 Qty 88

PAYMENT TERMS

Terms of payment for parts are net 10 days.

FREIGHT POLICY

All parts orders will be shipped collect or prepaid with the charges added to the invoice. All shipments are F.O.B. point of origin. Multiquip's responsibility ceases when a signed manifest has been obtained from the carrier, and any claim for shortage or damage must be settled between the consignee and the carrier.

MINIMUM ORDER

The minimum charge for orders from Multiquip is \$15.00 net. Customers will be asked for instructions regarding handling of orders not meeting this requirement.

RETURNED GOODS POLICY

Return shipments will be accepted and credit will be allowed, subject to the following provisions:

1. A Returned Material Authorization must be approved by Multiquip prior to shipment.
2. To obtain a Return Material Authorization, a list must be provided to Multiquip Parts Sales that defines item numbers, quantities, and descriptions of the items to be returned.
 - a. The parts numbers and descriptions must match the current parts price list.
 - b. The list must be typed or computer generated.
 - c. The list must state the reason(s) for the return.
 - d. The list must reference the sales order(s) or invoice(s) under which the items were originally purchased.
 - e. The list must include the name and phone number of the person requesting the RMA.
3. A copy of the Return Material Authorization must accompany the return shipment.

4. Freight is at the sender's expense. All parts must be returned freight prepaid to Multiquip's designated receiving point.
5. Parts must be in new and resalable condition, in the original Multiquip package (if any), and with Multiquip part numbers clearly marked.
6. The following items are not returnable:
 - a. Obsolete parts. (If an item is listed in the parts price book as being replaced by another item, it is obsolete.)
 - b. Any parts with a limited shelf life (such as gaskets, seals, "O" rings, and other rubber parts) that were purchased more than six months prior to the return date.
 - c. Any line item with an extended dealer net price of less than \$5.00.
 - d. Special order items.
 - e. Electrical components.
 - f. Paint, chemicals, and lubricants.
 - g. Decals and paper products.
 - h. Items purchased in kits.
7. The sender will be notified of any material received that is not acceptable.
8. Such material will be held for 5 working days from notification, pending instructions. If a reply is not received within 5 days, the material will be returned to the sender at his expense.
9. Credit on returned parts will be issued at dealer net price at time of the original purchase, less a 15% restocking charge.
10. In cases where an item is accepted for which the original purchase document can not be determined, the price will be based on the list price that was effective twelve months prior to the RMA date.
11. Credit issued will be applied to future purchases only.

PRICING AND REBATES

Prices are subject to change without prior notice. Price changes are effective on a specific date and all orders received on or after that date will be billed at the revised price. Rebates for price declines and added charges for price increases will not be made for stock on hand at the time of any price change.

Multiquip reserves the right to quote and sell direct to Government agencies, and to Original Equipment Manufacturer accounts who use our products as integral parts of their own products.

SPECIAL EXPEDITING SERVICE

A \$20.00 to \$50.00 surcharge will be added to the invoice for special handling including bus shipments, insured parcel post or in cases where Multiquip must personally deliver the parts to the carrier.

LIMITATIONS OF SELLER'S LIABILITY

Multiquip shall not be liable here under for damages in excess of the purchase price of the item with respect to which damages are claimed, and in no event shall Multiquip be liable for loss of profit or good will or for any other special, consequential or incidental damages.

LIMITATION OF WARRANTIES

No warranties, express or implied, are made in connection with the sale of parts or trade accessories nor as to any engine not manufactured by Multiquip. Such warranties made in connection with the sale of new, complete units are made exclusively by a statement of warranty packaged with such units, and Multiquip neither assumes nor authorizes any person to assume for it any other obligation or liability whatever in connection with the sale of its products. A part from such written statement of warranty, there are no warranties, express, implied or statutory, which extend beyond the description of the products on the face hereof.

PARTS MANUAL SUPPLEMENT

HERE'S HOW TO GET HELP

*PLEASE HAVE THE MODEL AND SERIAL NUMBER
ON-HAND WHEN CALLING*

PARTS DEPARTMENT

800/427-1244 or 310/537-3700

FAX: 800/672-7877 or 310/637-3284

SERVICE DEPARTMENT

800/478-1244 or 310/537-3700

FAX: (310) 537-4259

WARRANTY DEPARTMENT

800/421-1244, EXT. 279 or 310/537-3700

FAX: (310) 537-1173

MAIN

800/421-1244 or 310/537-3700

FAX: (310) 537-3927



MULTIQUIP INC.

POST OFFICE BOX 6254
CARSON, CA 90749
310-537-3700 • 800-421-1244
FAX: 310-537-3927
E-MAIL: mq@multiquip.com
WWW: multiquip.com

Atlanta • Boise • Dallas • Houston • Newark
Quebec, Canada • Manchester, UK • Rio De Janeiro, BR • Guadalajara, MX