

OPERATION AND PARTS MANUAL



MODELS

MQD2H

MQD3H

DIAPHRAGM PUMPS

(Honda GX120K1QX2 Gasoline Engine)

Revision #6 (10/27/11)

To find the latest revision of this
publication, visit our website at:
www.multiquip.com



THIS MANUAL MUST ACCOMPANY THE EQUIPMENT AT ALL TIMES.



 WARNING 
CALIFORNIA — Proposition 65 Warning
Engine exhaust and some of its constituents are known to the State of California to cause cancer, birth defects and other reproductive harm.

TABLE OF CONTENTS

MQ-D2H/D3H Gasoline Powered Diaphragm Pumps

Proposition 65 Warning	2
Table of Contents	4
Parts Ordering Procedures	5
Safety Information	6-9
Specifications	10
Dimensions	11
General Information	12
Components	13
Basic Engine	14
Inspection	15
Set-up	16-17
Operation	18-19
Maintenance	20-25
Preparation for Long-Term Storage	26
Troubleshooting	27-29
Explanation Of Code In Remarks Column	30
Suggested Spare Parts	31

Component Drawings

Nameplate and Decals Assy.	32-33
Waterbox and Flap Valve Assy. (2-inch)	34-35
Pump Assy. (2-inch)	36-37
Handle, Engine and Wheel Assy. (2-inch)	38-39
Waterbox and Flat Valve Assy. (3-inch)	40-41
Pump Assy. (3-inch)	42-43
Handle, Engine and Wheel Assy. (3-inch)	44-45

HONDA GX120K1QX2 Engine

Air Cleaner Assembly	46-47
Camshaft Assembly	48-49
Carburetor Assembly	50-51
Control Assembly	52-53
Crankcase Cover Assembly	54-55
Crankshaft Assembly	56-57
Cylinder Barrel Assembly	58-59
Cylinder Head Assembly	60-61
Fan Cover Assembly	62-63
Flywheel Assembly	64-65
Fuel Tank Assembly	66-67
Ignition Coil Assembly	68-69
Muffler Assembly	70-71
Piston Assembly	72-73
Recoil Starter Assembly	74-75
Gasket Kit Assembly	76-77
Labels	78-79
Terms and Condition Of Sale — Parts	80

NOTICE

Specification and part number are subject to change without notice.

PARTS ORDERING PROCEDURES

Ordering parts has never been easier! Choose from three easy options:

Effective:
January 1st, 2006



Order via Internet (Dealers Only):

Order parts on-line using Multiquip's SmartEquip website!

- View Parts Diagrams
- Order Parts
- Print Specification Information



If you have an MQ Account, to obtain a Username and Password, E-mail us at: parts@multiquip.com.

To obtain an MQ Account, contact your District Sales Manager for more information.

Goto www.multiquip.com and click on **Order Parts** to log in and save!

Use the **internet** and qualify for a **5% Discount** on *Standard orders* for all orders which include complete part numbers.*

Note: Discounts Are Subject To Change



Order via Fax (Dealers Only):

All customers are welcome to order parts via Fax.

Domestic (US) Customers dial:
1-800-6-PARTS-7 (800-672-7877)

Fax your order in and qualify for a **2% Discount** on *Standard orders* for all orders which include complete part numbers.*

Note: Discounts Are Subject To Change



Order via Phone: Domestic (US) Dealers Call:
1-800-427-1244

Non-Dealer Customers:

Contact your local Multiquip Dealer for parts or call 800-427-1244 for help in locating a dealer near you.



International Customers should contact their local Multiquip Representatives for Parts Ordering information.

When ordering parts, please supply:

- | | |
|---|--|
| <input type="checkbox"/> Dealer Account Number | <input type="checkbox"/> Specify Preferred Method of Shipment: |
| <input type="checkbox"/> Dealer Name and Address | <input checked="" type="checkbox"/> UPS/Fed Ex <input checked="" type="checkbox"/> DHL |
| <input type="checkbox"/> Shipping Address (if different than billing address) | <input type="checkbox"/> Priority One <input checked="" type="checkbox"/> Truck |
| <input type="checkbox"/> Return Fax Number | <input type="checkbox"/> Ground |
| <input type="checkbox"/> Applicable Model Number | <input type="checkbox"/> Next Day |
| <input type="checkbox"/> Quantity, Part Number and Description of Each Part | <input type="checkbox"/> Second/Third Day |

NOTICE

All orders are treated as *Standard Orders* and will ship the same day if received prior to 3PM PST.

WE ACCEPT ALL MAJOR CREDIT CARDS!



www.multiquip.com



SAFETY INFORMATION

Do not operate or service the equipment before reading the entire manual. Safety precautions should be followed at all times when operating this equipment. Failure to read and understand the safety messages and operating instructions could result in injury to yourself and others.



SAFETY MESSAGES

The four safety messages shown below will inform you about potential hazards that could injure you or others. The safety messages specifically address the level of exposure to the operator and are preceded by one of four words: **DANGER**, **WARNING**, **CAUTION** or **NOTICE**.

SAFETY SYMBOLS

 **DANGER**

Indicates a hazardous situation which, if not avoided, **WILL** result in **DEATH** or **SERIOUS INJURY**.

 **WARNING**

Indicates a hazardous situation which, if not avoided, **COULD** result in **DEATH** or **SERIOUS INJURY**.



 **CAUTION**

Indicates a hazardous situation which, if not avoided, **COULD** result in **MINOR** or **MODERATE INJURY**.

NOTICE

Addresses practices not related to personal injury.

Potential hazards associated with the operation of this equipment will be referenced with hazard symbols which may appear throughout this manual in conjunction with safety messages.

Symbol	Safety Hazard
	Rotating parts hazards
	Electric shock hazards

SAFETY INFORMATION

GENERAL SAFETY

CAUTION

- **NEVER** operate this equipment without proper protective clothing, shatterproof glasses, respiratory protection, hearing protection, steel-toed boots and other protective devices required by the job or city and state regulations.



- Avoid wearing jewelry or loose fitting clothes that may snag on the controls or moving parts as this can cause serious injury.

- **NEVER** operate this equipment when not feeling well due to fatigue, illness or when under medication.



- **NEVER** operate this equipment under the influence of drugs or alcohol.



- **ALWAYS** clear the work area of any debris, tools, etc. that would constitute a hazard while the equipment is in operation.

- No one other than the operator is to be in the working area when the equipment is in operation.

- **DO NOT** use the equipment for any purpose other than its intended purposes or applications.

NOTICE

- This equipment should only be operated by trained and qualified personnel 18 years of age and older.

- Whenever necessary, replace nameplate, operation and safety decals when they become difficult read.

- Manufacturer does not assume responsibility for any accident due to equipment modifications. Unauthorized equipment modification will void all warranties.

- **NEVER** use accessories or attachments that are not recommended by Multiquip for this equipment. Damage to the equipment and/or injury to user may result.

- **ALWAYS** know the location of the nearest **fire extinguisher**.



- **ALWAYS** know the location of the nearest **first aid kit**.



- **ALWAYS** know the location of the nearest phone or **keep a phone on the job site**. Also, know the phone numbers of the nearest **ambulance, doctor and fire department**. This information will be invaluable in the case of an emergency.



SAFETY INFORMATION

PUMP SAFETY

DANGER

- **NEVER** operate the equipment in an explosive atmosphere or near combustible materials. An explosion or fire could result causing severe **bodily harm or even death.**
- **NEVER** use pump for swimming pool dewatering applications. This can result in electrical shock or electrocution.



WARNING

- Accidental starting can cause severe injury or death. **ALWAYS** place the ON/OFF switch in the OFF position.
- **DO NOT** place hands or fingers inside pump when pump is running.
- **NEVER** disconnect any **emergency or safety devices.** These devices are intended for operator safety. Disconnection of these devices can cause severe injury, bodily harm or even death. Disconnection of any of these devices will void all warranties.



CAUTION

- **DO NOT** restrict the flow of the discharge hose as it may cause overheating.
- Be careful of discharge whipping under pressure.

NOTICE

- **ALWAYS** place the pump in an upright position on a platform before using. The platform will prevent the pump from burrowing itself on soft sand or mud.
- **NEVER** operate pump on its side.
- **DO NOT** allow up to freeze in water.
- **NEVER** leave an open pump chamber unattended.
- **ALWAYS** keep the machine in proper running condition.
- **DO NOT** attempt to thaw-out a frozen pump by using a torch or other source of flame. Application of heat in this manner may heat the oil in the seal cavity above the critical point, causing pump damage.

- **DO NOT** pump water greater than 104° F.
- **DO NOT** pump liquids containing acid or alkali.
- **ALWAYS** check strainer before pumping. Make sure strainer is not clogged. Remove any large objects, dirt or debris from the strainer to prevent clogging.
- **ALWAYS** use a large basket strainer when pumping water that contains large debris.
- **ALWAYS** flush pump (clean) after use when pumping water concentrated with heavy debris. It is very important to always flush the pump before turning it off to prevent clogging.
- Fix damage to machine and replace any broken parts immediately.
- **ALWAYS** store equipment properly when it is not being used. Equipment should be stored in a clean, dry location out of the reach of children and unauthorized personnel.
- **NEVER** lubricate components or attempt service on a running machine.
- **ALWAYS** allow the machine a proper amount of time to cool before servicing.
- Keep machine in proper running condition.

ELECTRICAL SAFETY

DANGER

- The electrical voltage required to operate pump can cause severe injury or even death through physical contact with live circuits. **ALWAYS** disconnect electrical power from pump before performing maintenance on pump.



NOTICE

- **ALWAYS** make certain that the voltage supplied to the pump is correct. Always read the pump's nameplate to determine what the power requirements are.

SAFETY INFORMATION

Power Cord/Cable Safety

DANGER

- **NEVER** let power cords or cables **lay in water**.
- **NEVER** use **damaged** or **worn** cables or cords. Inspect for cuts in the insulation.

- **NEVER** grab or touch a live power cord or cable with wet hands. The possibility exists of **electrical shock, electrocution or death**.

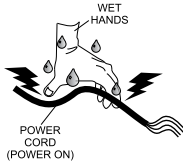

- Make sure power cables are securely connected to the motor's output receptacles. Incorrect connections may cause electrical shock and damage to the motor.

WARNING

- **NEVER** attempt to use the power cord as a lifting or lowering device for the pump.

NOTICE

- **ALWAYS** make certain that proper power or extension cord has been selected for the job. See Cable Selection Chart in this manual.

Grounding Safety

DANGER

- **ALWAYS** make sure pump is grounded.
- **ALWAYS** make sure that electrical circuits are properly grounded to a suitable earth ground (ground rod) per the National Electrical Code (NEC) and local codes before operating generator. **Severe injury or death by electrocution** can result from operating an ungrounded motor.
- **NEVER** use gas piping as an electrical ground.

LIFTING SAFETY

CAUTION

- When raising or lowering of the pump is required, always attach an adequate rope or lifting device to the correct lifting point (handle) on the pump.

NOTICE

- **DO NOT** lift machine to unnecessary heights.
- **NEVER** lift the equipment while the engine is running.

TRANSPORTING SAFETY

NOTICE

- **ALWAYS** shutdown pump before transporting.
- **ALWAYS** tie down equipment during transport by securing the equipment with rope.

ENVIRONMENTAL SAFETY

NOTICE

- Dispose of hazardous waste properly. Examples of potentially hazardous waste are used motor oil, fuel and fuel filters. 
- **DO NOT** use food or plastic containers to dispose of hazardous waste.
- **DO NOT** pour waste, oil or fuel directly onto the ground, down a drain or into any water source.

SPECIFICATIONS

Table 1. Specifications (Pump)

	Type	MQ-D2H Diaphragm Pump	MQ-D3H Diaphragm Pump
Pump	Suction & Discharge Size	2.00 in. (50.8 mm.)	3.00 in. (76.2 mm.)
	Maximum Pumping Capacity	3,000 gallons/hour (11,340 liters/hour)	5,400 gallons/hour (20,456 liters/hour)
	Max. Solids Diameter	1-1/2 in. (38.1 mm)	1-5/8 in (41.275 mm)
	Max Lift	26 ft. (7.92 meters)	26 ft. (7.92 meters)
	Max. Head	25 ft. (7.62 meters)	25 ft. (7.62 meters)
	Dry Net Weight		140 lbs. (63 Kg.)

Table 2. Specifications (Engine)

Engine	Model	HONDA GX120K1QX2
	Type	Air-cooled 4 stroke, Single Cylinder, OHV, Horizontal Shaft Gasoline Engine
	Bore X Stroke	2.4 in. x 1.7 in. (60 mm x 42 mm)
	Displacement	119 cc (7.2 cu-in)
	Max Output	4.0 H.P./2,750 R.P.M.
	Fuel Tank Capacity	0.66 US gal. (2.5 liters)
	Fuel	Unleaded Automobile Gasoline
	Lube Oil Capacity	.60 liters (0.63 qts)
	Speed Control Method	Centrifugal Fly-weight Type
	Starting Method	Recoil Start
Dimension (L x W x H)	11.7 x 13.4 x 12.5 in. (297 x 341 x 318 mm)	
Dry Net Weight	28.7 lbs (13 Kg.)	

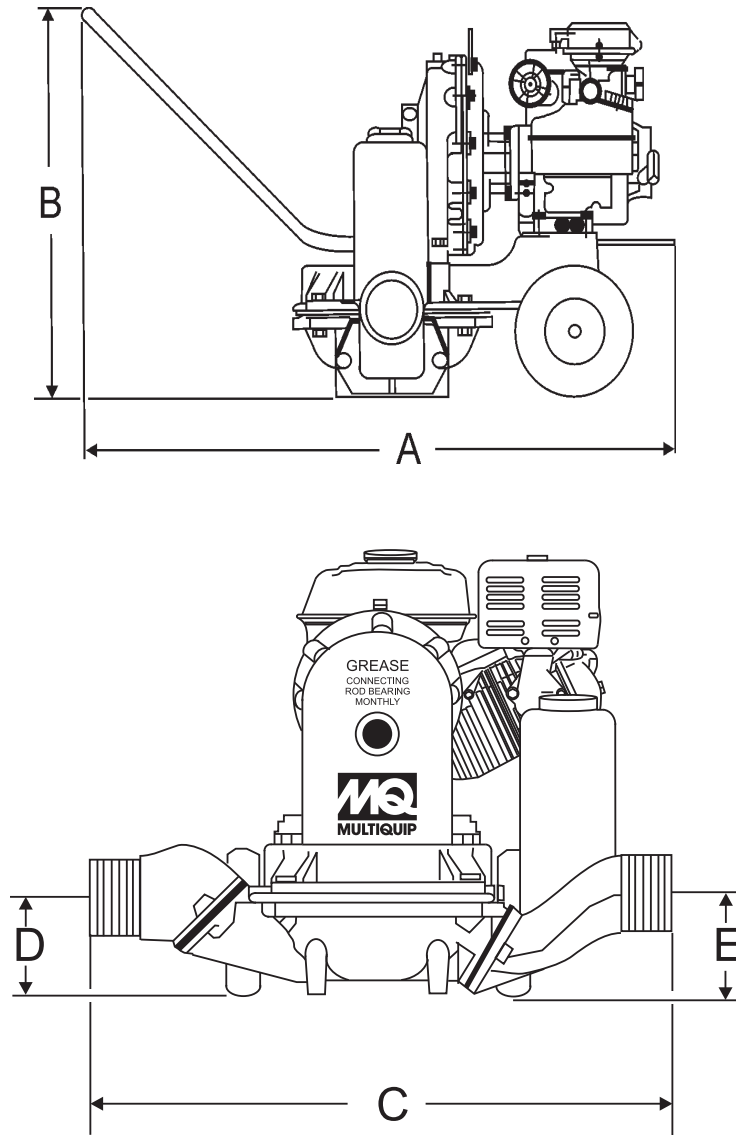

Figure 1. MQ-D2H/D3H Pump Dimensions

Table 3. Dimensions					
MODEL	A LENGTH	B HEIGHT	C WIDTH	D DISCHARGE	E SUCTION
MQ-D2H	39 in. (99.06 cm.)	27.53 in. (69.93 cm.)	25.68 in. (65.23 cm.)	7.34 in. (18.64 cm.)	5.62 in. (14.27 cm.)
MQ-D3H	41.5 in. (105.41 cm.)	22 in. (55.88 cm.)	30 in. (76.2 cm.)	6.2 in. (15.75 cm.)	6.3 in. (16 cm.)

GENERAL INFORMATION

APPLICATION

The **MQD2H** and **MQD3H diaphragm** pumps are designed to be used for de-watering applications. The suction and discharge ports on the **MQD2H** use a 2-inch diameter opening, which allows the pump to pump at rate of approximately 3,000 gallons/hour (gph) or 11,340 liters/hour (lph). The suction and discharge ports on the **MQD3H** use a 3-inch diameter opening, which allows the pump to pump at rate of approximately 5,400 gallons/hour (gph) or 20,456 liters/hour (lph).

Diaphragm pumps use a positive displacement design rather than centrifugal force to move water through the casing. This means the pump will deliver a specific amount of flow per stroke, revolution or cycle. These pumps are commonly referred to as mud hogs, mud hens and mud suckers. Their names reflect their popularity for use in applications where shallow depths and slurry water render centrifugal pumps ineffective.

Power Plant

These diaphragm pumps are powered by a 4.0 horsepower air cooled, 4-stroke, single cylinder **HONDA GX120** gasoline engine that incorporates a low “**Oil Alert Feature**”. The drive shaft of the engine is coupled to an offset connecting rod that is coupled to a flexible diaphragm. The connecting rod alternately raises (expands) and lowers (contracts) the diaphragm at a rate of 60 cycles per minute at maximum engine RPM (2,750).

Oil Alert Feature

In the event of **low oil** or **no oil**, the HONDA GX120 engine has a built-in oil alarm engine shut-down feature. In the event the oil level is low the engine will automatically shut-down.

Suction Lift

This pump is intended to be used for dewatering applications and is capable of suction lifts up to 25 feet at sea level. For optimal suction lift performance keep the suction hose or line as short as possible. In general always place the pump as close to the water as possible.

Pump Support

The pump should always be placed on **solid stationary ground** in a level position.

NEVER place the pump on **soft soil**. The suction hose or pipe connection should always be checked for tightness and leaks. A small suction leak in the hose or fittings could prevent the pump from priming.

Elevation

Higher elevations will effect the performance of the pump. Due to less atmospheric pressure at higher altitudes, pumps **DO NOT** have the priming ability that they have at sea level. This is due to the “thinner air” or lack of oxygen at higher altitudes.

A general rule of thumb is that for every 1,000 feet of elevation above sea level a pump will lose one foot of priming ability.

For example, in Flagstaff, Arizona where the elevation is approximately 7,000 feet, the pump would have a suction lift of only 18 feet rather than the 25 feet at sea level. Table 3 shows suction lift at various elevations.

Table 4. Suction Lift at Various Elevations

Altitude Feet (Meters)	Suction Lift in Feet (Meters)			
	10.0 (3.048)	15.0 (4.572)	20.0 (6.096)	25.0 (7.620)
Sea Level	10.0 (3.048)	15.0 (4.572)	20.0 (6.096)	25.0 (7.620)
2,000 (610)	8.80 (2.680)	13.2 (4.023)	17.6 (5.364)	22.0 (6.705)
4,000 (1,219)	7.80 (2.377)	11.7 (3.566)	15.6 (4.754)	19.5 (5.943)
6,000 (1,829)	6.90 (2.103)	10.4 (3.169)	13.8 (4.206)	17.3 (5.273)
8,000 (2,438)	6.20 (1.889)	9.30 (2.834)	12.4 (3.779)	15.5 (4.724)
10,000 (3,048)	5.70 (1.737)	8.60 (2.621)	11.4 (3.474)	14.3 (4.358)

Table 4 shows percentage drops in performance as elevation increases.

Table 5. Performance Loss at Various Elevations

Altitude Feet (Meters)	Discharge Flow	Discharge Head
Sea Level	100%	100%
2,000 (610)	97%	95%
4,000 (1,219)	95%	91%
6,000 (1,829)	93%	87%
8,000 (2,438)	91%	83%
10,000 (3,048)	88%	78%

Figure 2 shows a typical application using the MQD2H or MQD3H diaphragm pump. Please note that this pump is intended for the removal of clean water and water containing some debris and solids. Maximum size of solids for the MQD2H should not exceed 1-1/2 inches (38.1 mm) in diameter, and maximum size of solids for the MQD3H should not exceed 1-5/8 inches (41.275) in diameter. **DO NOT** set strainer on bottom of water bed. Placing the strainer above the water bed will prevent the pump from drawing in excessive amounts of sand and foreign debris.

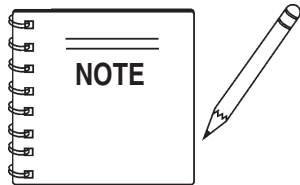

Contact your nearest Multiquip dealer for quick disconnect hoses and fittings.

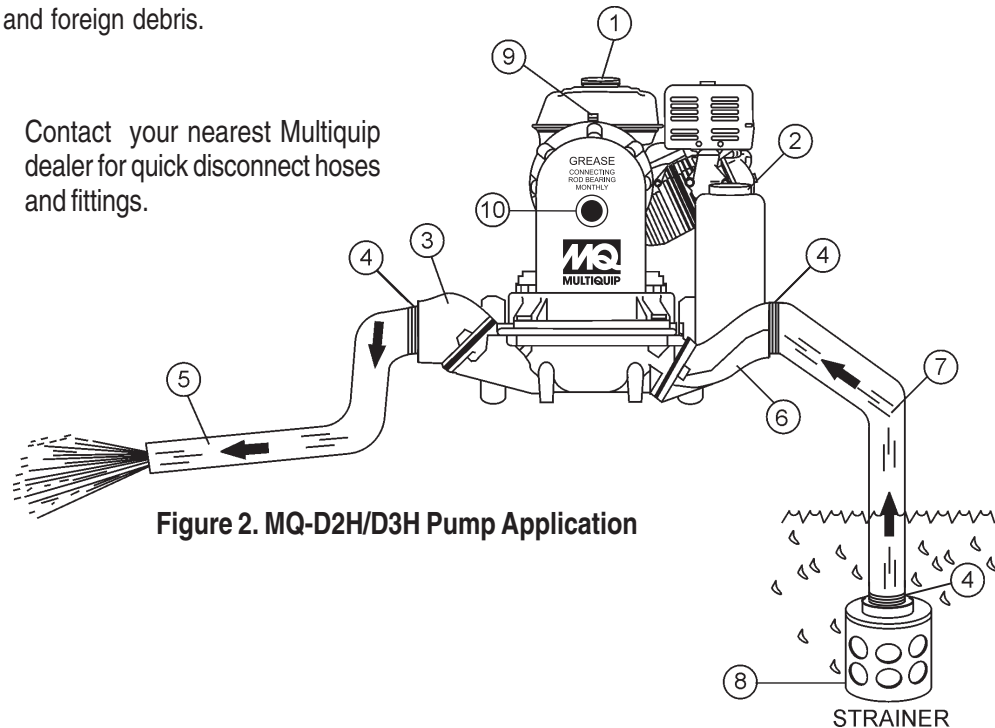

Figure 2. MQ-D2H/D3H Pump Application

1. **Pump** – The **Multiquip** Models MQD2H and MQD3H are 2-inch and 3-inch diaphragm pumps respectively and are used in general de-watering applications. Typical dewatering applications consist of cleaning out cesspools and septic tanks, draining slow seepage from small excavations, trenches and construction sites, or pumping out industrial waste.
2. **Priming Plug/Suction Priming Chamber** – Fill with clean water to assist with faster priming times.
3. **Discharge Port** – Connect either a 2-inch or 3-inch discharge hose to this port depending on pump model.
4. **NPT Connection** – Used to secure the hose to the inlet and outlet ports on the pump.
5. **Discharge Hose** – Connect a flexible rubber hose to the discharge port on the pump. Make sure that the hose lays flat and is not kinked. Use only recommended type discharge hose. Contact Multiquip parts department for ordering information.
6. **Suction Port** – Connect either a 2-inch or 3-inch inlet hose to this port depending on pump model.
7. **Suction Hose** – Connect a flexible rubber hose to the suction port on the pump. Make sure that the hose lays flat and is not kinked. Use only recommended type suction hose. Contact Multiquip parts department for ordering information.
8. **Strainer** – Always attach a strainer to bottom side of the suction hose to prevent large objects and debris from entering the pump. Strainer should be positioned so that it will remain completely under water.
9. **Transmission Oil Fill Plug** – Remove this plug to add SAE 80/90 EP (API GL-5) gear oil to the transmission. Transmission oil capacity is 22 ounces (651 ml.).
10. **Connecting Rod Grease Access Hole** – Grease connecting rod bearing through this access hole. Grease connecting rod bearing every 25 hours of operation.

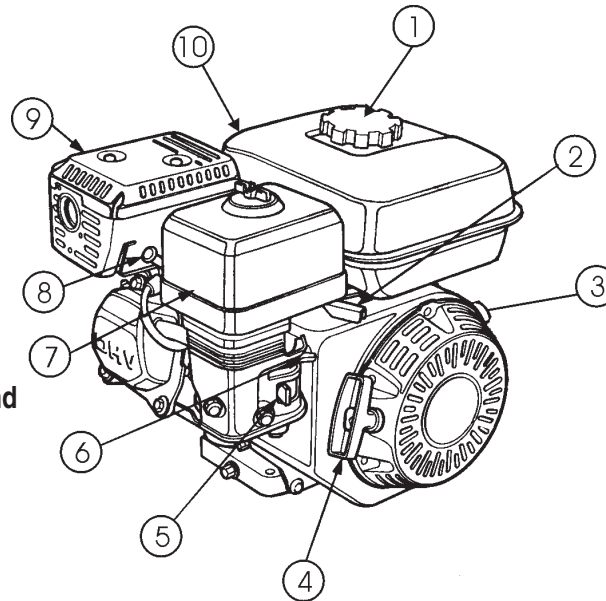

Figure 3. Engine Controls and Components

INITIAL SERVICING

The engine (Figure 3) must be checked for proper lubrication and filled with fuel prior to operation. Refer to the Honda manufacturers engine manual for instructions and details for operation and servicing.

1. **Fuel Filler Cap** – Remove this cap to add unleaded gasoline to the fuel tank. Make sure cap is tightened securely. **DO NOT** over fill.

6. **Choke Lever** – Used in the starting of a cold engine, or in cold weather conditions. The choke enriches the fuel mixture.
7. **Air Cleaner** – Prevents dirt and other debris from entering the fuel system. Remove wing-nut on top of air filter cannister to gain access to filter element.

! DANGER - Explosive Fuel

Adding fuel to the tank should be done only when the engine is stopped and has had an opportunity to cool down. In the event of a fuel spill, **DO NOT** attempt to start the engine until the fuel residue has been completely wiped up, and the area surrounding the engine is dry.



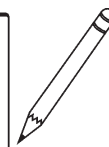
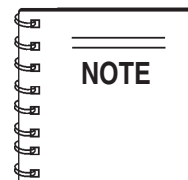

Operating the engine without an air filter, with a damaged air filter, or a filter in need of replacement will allow dirt to enter the engine, causing rapid engine wear.

2. **Throttle Lever** – Used to adjust engine RPM speed (lever advanced forward **SLOW**, lever back toward operator **FAST**).
3. **Engine ON/OFF Switch** – ON position permits engine starting, OFF position stops engine operations.
4. **Recoil Starter (pull rope)** – Manual-starting method. Pull the starter grip until resistance is felt, then pull briskly and smoothly.
5. **Fuel Valve Lever** – **OPEN** to let fuel flow, **CLOSE** to stop the flow of fuel.

8. **Spark Plug** – Provides spark to the ignition system. Set spark plug gap to 0.6 - 0.7 mm (0.028 - 0.031 inch) Clean spark plug once a week.
9. **Muffler** – Used to reduce noise and emissions.

! CAUTION - Burn Hazard

Engine components can generate extreme heat. To prevent burns, **DO NOT** touch these areas while the engine is running or immediately after operating. **NEVER** operate the engine with the muffler removed.



10. **Fuel Tank** – Holds unleaded gasoline. For additional information refer to engine owner's manual.

! CAUTION - Read Manual

Please read the entire maintenance section in this manual before servicing the pump. In addition for operator safety, please read all safety messages at the beginning of the manual



Inspection

1. Clean the pump, removing dirt and dust, particularly the engine cooling air inlet, carburetor and air cleaner.
2. Check the air filter for dirt and dust. If air filter is dirty, replace air filter with a new one as required.
3. Check carburetor for external dirt and dust. Clean with dry compressed air.
4. Check fastening nuts and bolts for tightness.

Engine Oil Check

1. To check the engine oil level, place the pump on secure level ground with the engine stopped.
2. Remove the filler dipstick from the engine oil filler hole (Figure 4) and wipe clean.

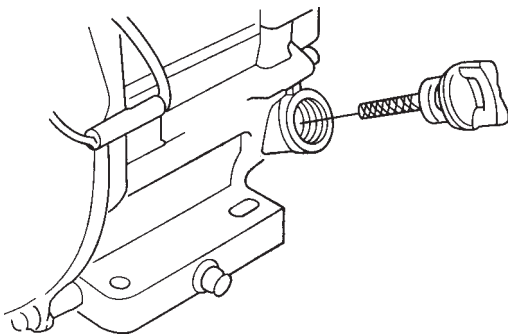

Figure 4. Engine Oil Dipstick (Removal)

3. Insert and remove the dipstick without screwing it into the filler neck. Check the oil level shown on the dipstick.
4. If the oil level is low (Figure 5), fill to the edge of the oil filler hole with the recommended oil type (Table 5). Maximum oil capacity is .63 quarts (.60 liters).

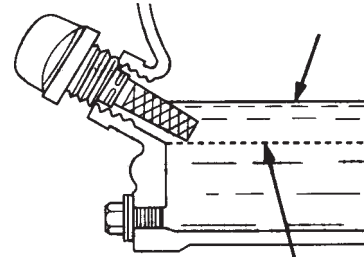



Figure 5. Engine Oil Dipstick (Oil Level)

Table 6. Oil Type

Season	Temperature	Oil Type
Summer	25°C or Higher	SAE 10W-30
Spring/Fall	25°C~10°C	SAE 10W-30/20
Winter	0°C or Lower	SAE 10W-10

! DANGER - Explosive Fuel

Motor fuels are highly flammable and can be dangerous if mishandled. **DO NOT** smoke while refueling. Adding fuel to the tank should be done only when the engine is stopped and has had an opportunity to cool down. **DO NOT** attempt to refuel the pump if the engine is **hot!** or **running!** In the event of any spilled fuel, wipe up immediately. **DO NOT** attempt to start the engine until the fuel residue has been completely wiped up, and the area surrounding the engine is dry.



Fuel Check

1. Remove the gasoline cap located on top of fuel tank.
2. Visually inspect to see if the fuel level is low. If fuel is low, replenish with unleaded fuel.
3. When refueling, be sure to use a strainer for filtration. **DO NOT** top-off fuel. Wipe up any spilled fuel **immediately!**

Handle Installation

The MQ-D2H/D3H diaphragm pumps are completely assembled except for the steering handle. Attach the steering handle to the pump base as shown in Figure 6.

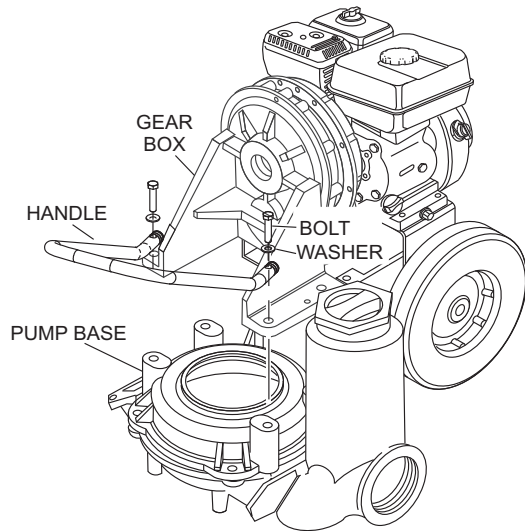



Figure 6. Handle Installation

Before Starting:

! CAUTION - General Safety Precautions

NEVER operate the pump in a confined area or enclosed area structure that does not provide ample **free flow of air**.



! ALWAYS wear approved eye and hearing protection before operating the pump.



Before Starting

1. Read safety instructions at the beginning of manual.
2. Place pump as near to water as possible, on a firm flat, level surface.



! WARNING - Fill Cap

DO NOT open **fill cap** if pump is **hot!** Water inside may be under pressure.

Hoses and Clamps

1. Check that all hoses are **securely** attached to the pump. Make certain suction hose (Figure 2) does not have any air leakage. Use teflon tape or pipe dope on NPT threads.
2. Remember suction hoses must be **rigid** enough not to collapse when the pump is in operation.
3. Check that the **discharge** hose (Figure 2) is not restricted. Place hose so that it lays as straight as it is possible on the ground. Remove any twists or sharp bends from hose which may block the flow of water.

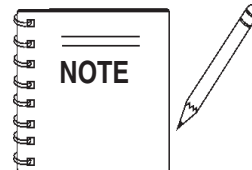

NOTE Suction and discharge hoses are available from Multiquip. Contact your nearest dealer for more information.

4. The discharge hose is usually a **collapsible** (thin-walled) hose, however if a thin-walled discharge hose is not available, a rigid suction hose can be substituted in its place.
5. Make sure the **suction strainer** (Figure 2) is clean and securely attached to the water end of the suction hose. The strainer is designed to protect the pump by preventing large objects from being pulled into the pump.

! CAUTION - Transmission Fluid

Transmission fluid needs to be added prior to operation.

! CAUTION - Strainer
 The strainer should be positioned so it will remain completely **under water**. Running the pump with the strainer above water for long periods can damage the pump.

! CAUTION - Flammable Fluids
DO NOT pump flammable fluids, corrosive chemicals or fluids containing toxic substances. These fluids can create potentially dangerous health and environmental hazards. Contact local authorities for assistance.

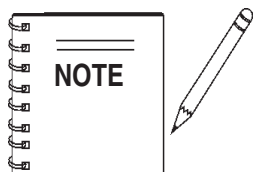

This pump uses a water-cooled **mechanical seal** to prevent water from seeping into the engine. The passage of water through the pump casing lubricates the seal and prevents it from overheating.

Gear Reduction Oil (Transmission)

1. Remove the **transmission oil level plug** (Figure 7). If oil begins to seep out as the plug is being removed, then it can be assumed that the transmission oil is at the proper operating level.
2. If oil does not seep out as the oil level plug is being removed, then remove the **transmission oil fill plug** and fill with **SAE 80/90 EP (API GL-5) gear oil** to the proper operating level. Transmission oil capacity is 22 ounces (651 ml).

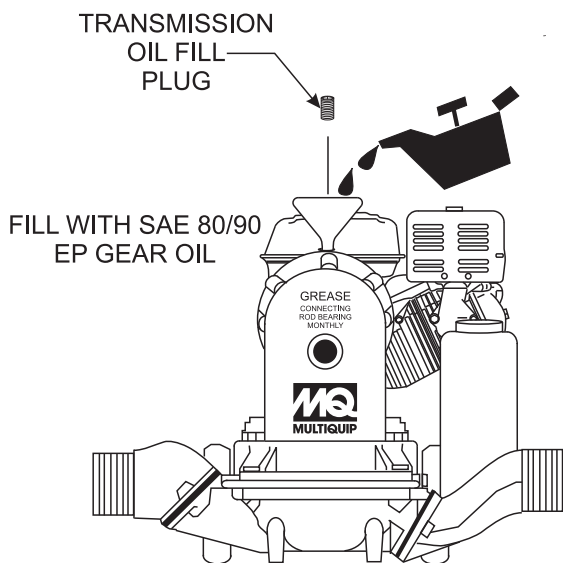
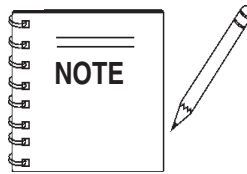

Figure 7. Transmission Oil Level



Diaphragm pumps will handle fluids containing considerable solids (see Table 1 for maximum solids diameter), however, if the mixture is too heavy to be pumped, water must be added until the mixture becomes sufficiently fluid for pumping.

Connecting Rod Bearing Lubrication

1. Grease **connecting rod bearing** thru the access hole (Figure 8) every 25 hours of operation.
2. Use only **premium lithium based grease**, conforming to NLG1 Grade #2 consistency.

APPLY 2 OR 3 SHOTS OF PREMIUM LITHIUM BASE GREASE EVERY 25 HOURS OF OPERATION

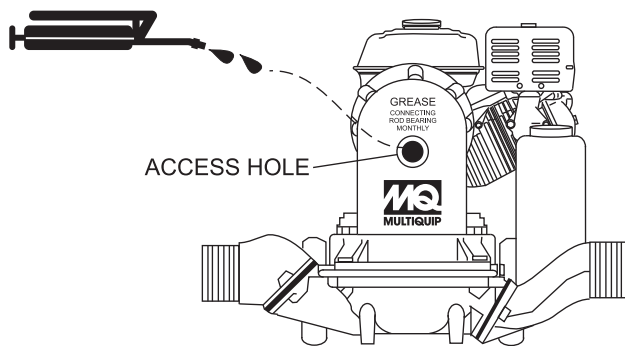

Figure 8. Connecting Rod Bearing Lubrication

Helpful Hints

The capacity of this diaphragm pump will vary greatly depending on the height of the suction lift and length of the discharge hose. A discharge hose which is too small, long or high will cause the following:

- Excessive bulging of diaphragm on the down stroke.
- Valves closing with a loud snap.
- Rough operation.
- Engine overloads and slow downs.
- Reduced efficiency.

CAUTION - Read Manual

DO NOT attempt to operate the pump until the Safety, General Information and Inspection sections of this manual have been **read and thoroughly understood**.



This section is intended to assist the operator with the **initial start-up** of the trash pump. It is extremely important that this section be read carefully before attempting to use the pump in the field.

Starting the Engine (HONDA engine)

1. Place the engine **fuel valve lever** (Figure 9) to the "ON" position.

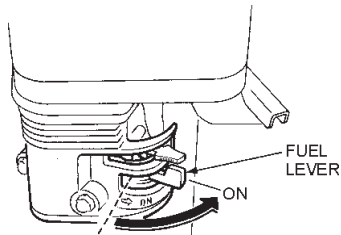

Figure 9. Engine Fuel Valve Lever (ON Position)

2. Move the **throttle lever** (Figure 10) away from the slow position, about 1/3 of the way toward the fast position.

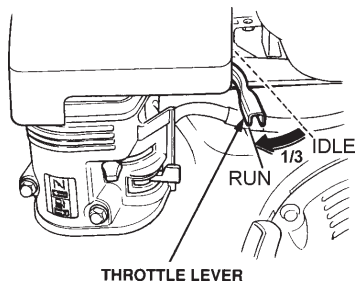

Figure 10. Throttle Lever (1/3 Start Position)

3. Place the **choke lever** (Figure 11) in the "CLOSED" position if starting a **cold** engine.

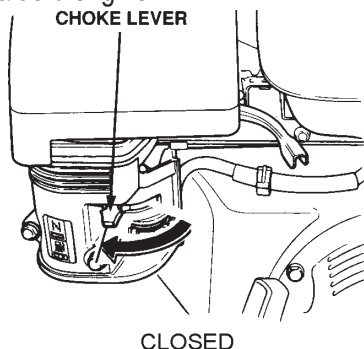

Figure 11. Engine Choke Lever (CLOSED)

4. Place the **choke lever** (Figure 12) in the "OPEN" position if starting a **warm engine** or the **temperature is warm**.

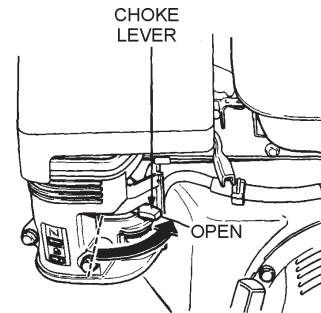

Figure 12. Engine Choke Lever (Open)

5. Place the **engine ON/OFF switch** (Figure 13) in the "ON" position.

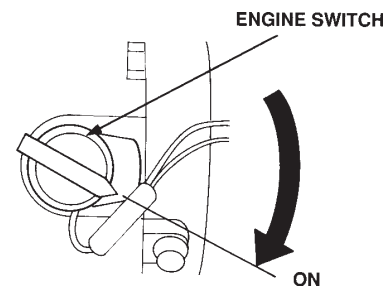

Figure 13. Engine ON/OFF Switch (ON Position)

6. Grasp the starter grip (Figure 14) and slowly pull it out. The resistance becomes the hardest at a certain position, corresponding to the compression point. Pull the starter grip briskly and smoothly for starting.

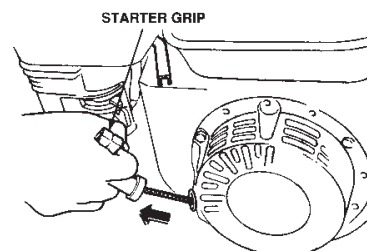

Figure 14. Starter Grip

- If the engine has started, slowly return the choke lever (Figure 15) to the “OPEN” position. If the engine has not started repeat steps 1 through 6.

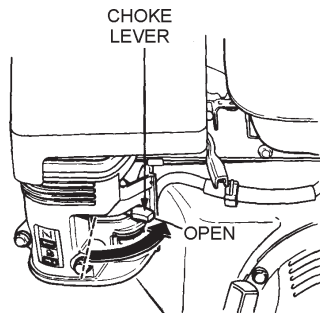

Figure 15. Choke Lever (Open)

- Before the pump is placed into operation, run the engine for several minutes. Check for fuel leaks, and noises that would associate with a loose component.
- To begin pumping, place the throttle lever (Figure 16) in the “RUN” position.

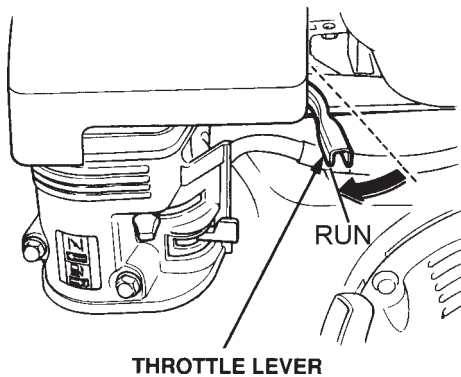
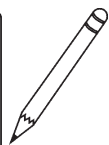
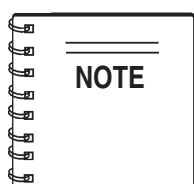

Figure 16. Throttle Lever (Run)



Pump speed can be **regulated** with the engine throttle control from full volume, 65 strokes per minute, to about 40 strokes per minute for lesser volume seepage. Smoothest operation can be determined by trying to pump at several speeds. Limit maximum speed to 65 strokes per minute of the diaphragm (2,800 RPM engine speed).

Stopping The Engine

Normal Shutdown

- Move the throttle lever to the **IDLE** position (Figure 17) and run the engine for three minutes at low speed.

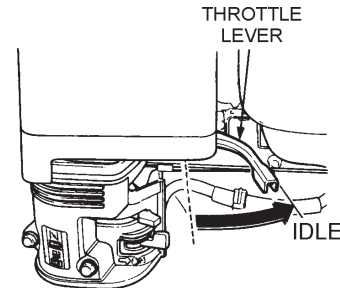

Figure 17. Throttle Lever (Idle)

- After the engine **cools**, turn the engine ON/OFF switch to the “OFF” position (Figure 18).

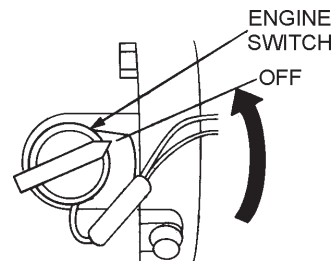

Figure 18. Engine ON/OFF Switch (OFF)

- Place the **fuel shut-off lever** (Figure 19) in the “OFF” position.

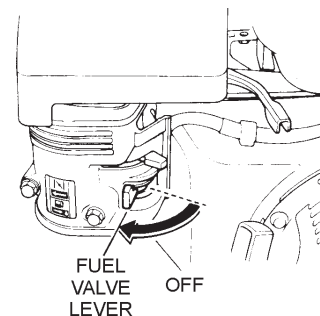

Figure 19. Fuel Valve Lever (OFF)

Emergency Showdown

- Move the throttle lever quickly to the “**IDLE**” position, and place the engine ON/OFF switch in the “**OFF**” position.

Pump Vacuum Test

To perform the pump vacuum test do the following:

1. Start the engine as outlined in the initial start-up section, and wait for the pump to begin pumping.
2. Check and make sure that there are no air leaks between the vacuum tester (Figure 21) and the inlet port on the pump. If air leaks are present reseal vacuum tester.
3. Run the pump for a few minutes while monitoring the vacuum gauge. If the gauge indicates a reading between -25 and -20 in. Hg. (inches of mercury) then it can be assumed that the pump is working correctly.

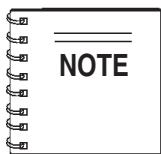

22 in. Hg (inches of mercury) translates into 25 feet of lift at **sea level**.

4. If the vacuum tester gauge indicates a reading **below** -20 in. Hg, it can then be assumed that the pump is not functioning correctly, and corrective action needs to be taken.
5. To test the **flapper valve**, shut down the engine. The vacuum tester should remain attached to the pump suction inlet port by vacuum. This indicates the pump's flapper valve is seating properly to hold water in the suction hose when the engine is stopped. This prevents backflow and allows for faster priming when the engine is restarted.

Flapper Valve Replacement

1. Remove the two bolts that secure the suction port chamber (Figure 20) to the pump well. Remove suction port chamber. Replace valves as required and reassemble.

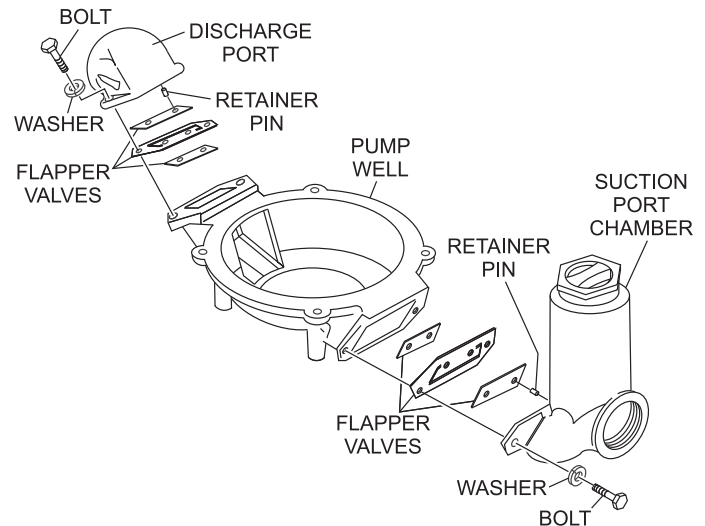

Figure 20. Flapper Valve Replacement

2. Remove the two bolts that secure the discharge port (Figure 20) to the pump well. Remove discharge port plate. Replace valves as required and reassemble.

Gear Reduction Oil (Transmission)

1. Check gearbox oil level every **20 hours** of operation or at least once a week; more often if any leakage is detected around the gearbox.
2. Change transmission oil after the first **40 hours** of operation. Use **SAE 80/90 EP (API GL-5) gear oil**. Transmission oil capacity is 22 ounces (651 ml.). Check oil level periodically and change oil after every **350 hours** of operation.

Connecting Rod Bearing Lubrication

1. Grease **connecting rod bearing** (Figure 8) every 8 hours of operation. This is done by rotating the rod bearing to the 12 o'clock position. At this point the grease fitting will be visible through the guard hole.
2. Use only **premium lithium based grease**, conforming to NLG1 Grade #2 consistency.
3. Remove connecting rod guard occasionally and wipe up excess grease from connecting rod bearing.

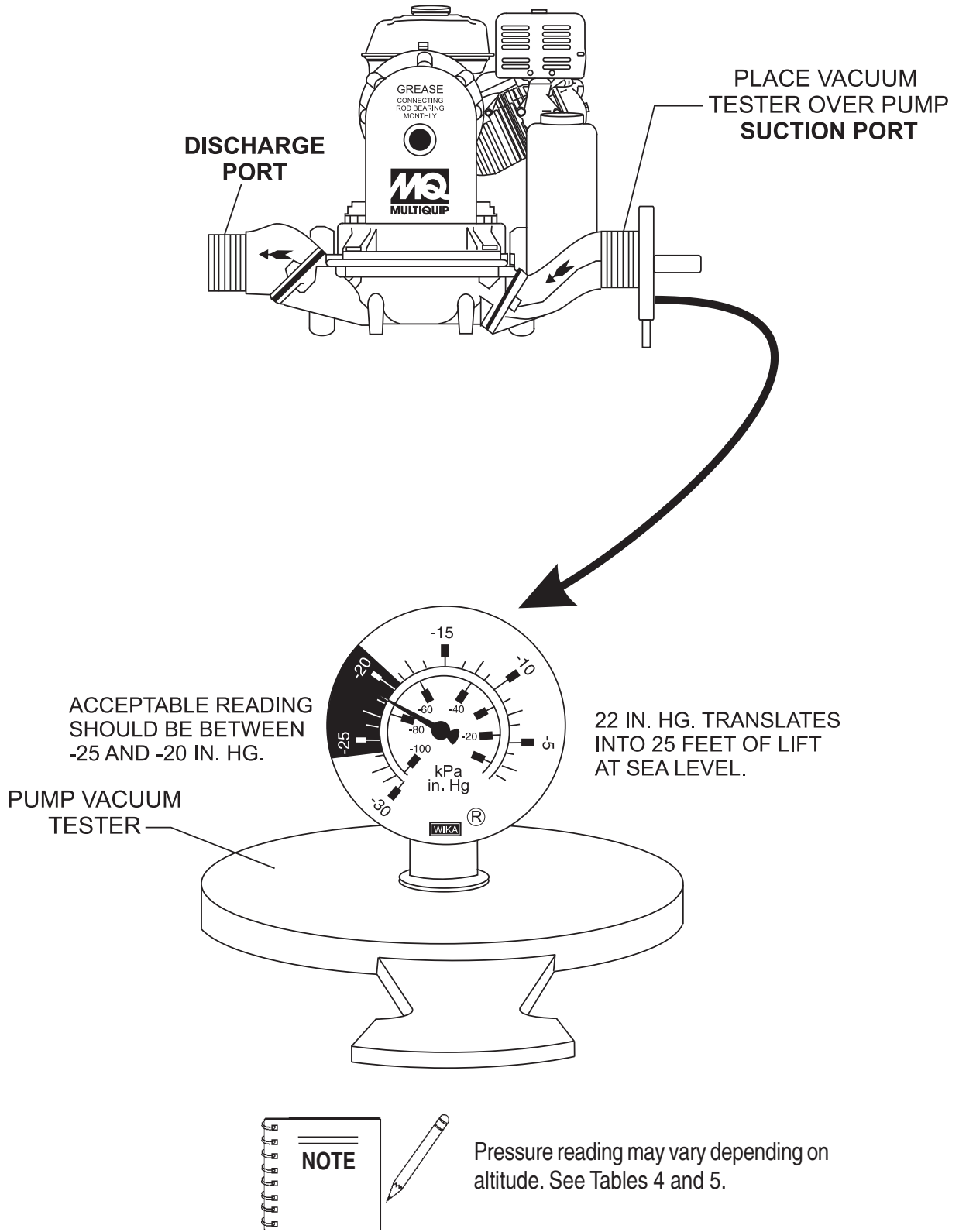

Figure 21. Pump Vacuum Tester

Rotation of Suction and Discharge Ports

In some applications, it may be preferable to have suction/discharge ports rotated 90° (Figure 22) to be in-line with the pump wheels. Perform the following procedure to rotate ports:

1. Remove the four hex head cap screws, hex nuts, flat washers and lock washers from the pump base.
2. Push pump well downwards to separate from pump base.
3. Rotate pump well 90° clockwise so that driver is positioned over top of discharge plate.
4. Align pump well, pump base, and diaphragm with each other. Once all components have been properly aligned, reinstall the four hex head cap screws, hex nuts, flat washers and lock washers and tighten securely.

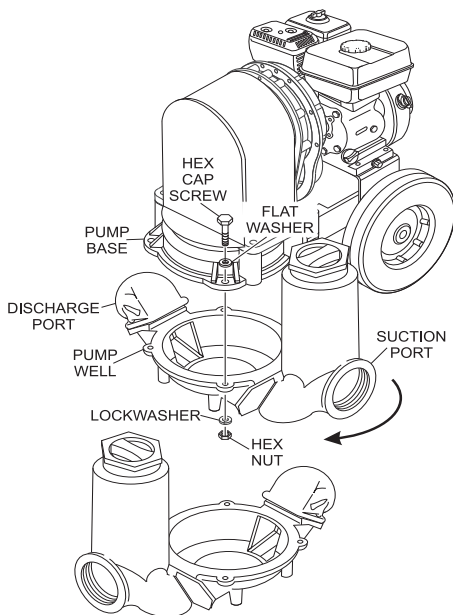

Figure 22. Suction/Discharge Port Rotation

Clearing a Jam-Up

If large solids or an accumulation of sand or other sediment becomes lodged in the pump well, preventing the plunger arm from making a full stroke; the pump may stall, the crank could slip on the output shaft, or the plunger arm could incur extreme damage and shear.

If a jam-up does occur, the pump should be thoroughly cleaned as described on the “Pump Stalls” section.

! CAUTION - Stalled or Stopped Pump

If pump has stopped or stalled for any unknown reason, **clean out pump cavity (well)** thoroughly. Failure to comply could result in damage to plunger arm or other internal pump components.

Stalled Pump

If pump has stalled for any unknown reason perform the following:

1. Remove handle from pump. See Figure 6.
2. Remove the four hex head cap screws, hex nuts, flat washers and lock washers from the pump base.
3. Push pump well downwards (Figure 23) to separate from pump base.
4. Clean and remove all dirt and debris from pump well.
5. Align pump well, pump base, and diaphragm with each other. Once all components have been properly aligned, reinstall the four hex head cap screws, hex nuts, flat washers and lock washers and tighten securely.

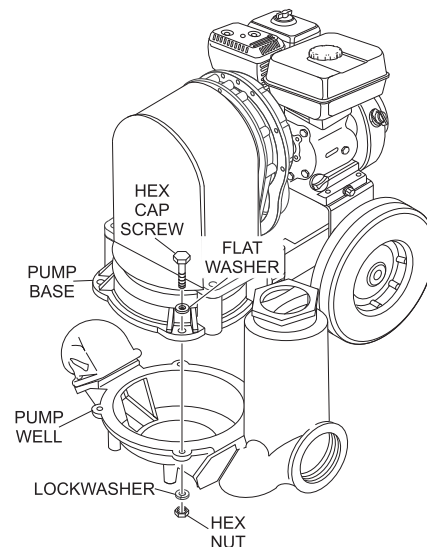

Figure 23. Pump Well (Clean-out)

! WARNING - Lock Screw Torqueing

Pump jamming with an over-torqued lock screw (plunger arm) may cause internal damage. Under torqueing may allow the output shaft to spin and wear parts prematurely causing replacement.

Seized Plunger

If the plunger arm has seized, perform the following:

1. Remove plunger guard (Figure 24) by turning guard hand knob counterclockwise to loosen.
2. Disassemble pump and clean as described in steps 1 thru 4 in the "Stalled Pump" section.
3. Using a torque wrench, torque lock screw (Figure 24) to 70 ft.-lbs. (9.6 kg-m).

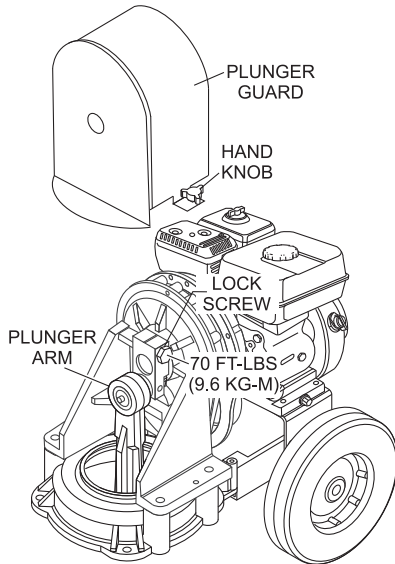

Figure 24. Lock Screw Torqueing

Diaphragm Replacement

1. Remove plunger cover as shown in step 1 of the "Seized Plunger" section.
2. Remove handle as shown in Figure 6 of the "Handle Installation" section.
3. Rotate pump output shaft until plunger arm is in the down position.
4. Remove the four hex head cap screws, hex nuts, flat washers and lock washers from the pump base.
5. Push pump well downwards to separate from pump base.
6. Remove the three carriage bolts (Figure 25) that secure the diaphragm to the plunger arm base. Remove diaphragm.
7. Replace diaphragm, reassemble in reverse order.

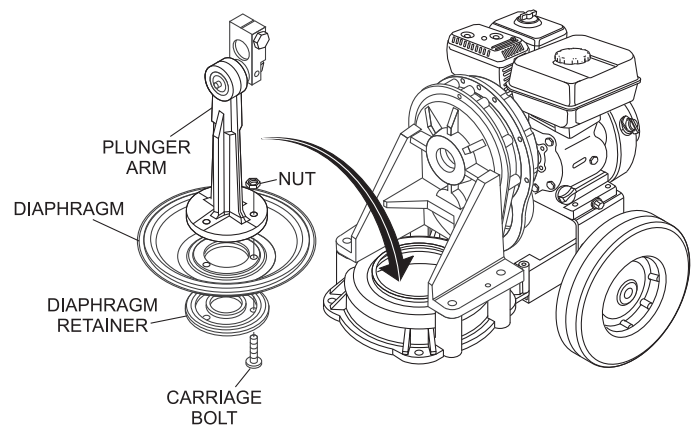

Figure 25. Diaphragm Replacement

Engine Maintenance

Perform engine maintenance procedures as referenced by Table 7 below:

Table 7. Engine Maintenance Schedule							
DESCRIPTION (3)	OPERATION	BEFORE	FIRST MONTH OR 10 HRS.	EVERY 3 MONTHS OR 25 HRS.	EVERY 6 MONTHS OR 50 HRS.	EVERY YEAR OR 100 HRS.	EVERY 2 YEARS OR 200 HRS.
Engine Oil	CHECK	X					
	CHANGE		X				
Air Cleaner	CHECK	X					
	CHANGE			X (1)			
All Nuts & Bolts	Re-tighten If Necessary	X					
Spark Plug	CHECK-CLEAN				X		
	REPLACE						X
Cooling Fins	CHECK				X		
Spark Arrester	CLEAN					X	
Fuel Tank	CLEAN					X	
Fuel Filter	CHECK					X	
Idle Speed	CHECK-ADJUST					X (2)	
Valve Clearance	CHECK-ADJUST						X (2)
Fuel lines	CHECK	Every 2 years (replace if necessary) (2)					

(1) Service more frequently when used in **DUSTY** areas.

(2) These items should be serviced by your servic dealer, unless you have the proper tools and are mechanically proficient. Refer to the HONDA shop Manual for service procedures

(3) For commercial use, log hours of operation to determine proper maintenance intervals.

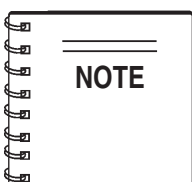

Reference manufacturer engine manual for specific servicing instructions.

Maintenance

Perform the engine maintenance procedures as indicated below:

DAILY

- Thoroughly remove dirt and oil from the engine and control area. Clean or replace the air cleaner elements as necessary. Check and retighten all fasteners as necessary. Check the spring box and bellows for oil leaks. Repair or replace as needed.

WEEKLY

- Remove the fuel filter cap and clean the inside of the fuel tank.
- Remove or clean the filter at the bottom of the tank.
- Remove and clean the spark plug (Figure 26), then adjust the spark gap to 0.028 ~0.031 inch (0.6~0.7 mm). This unit has electronic ignition, which requires no adjustments.

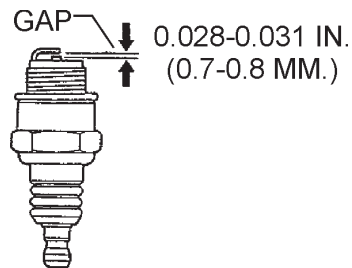

Figure 26. Spark Plug Gap

ENGINE OIL

1. Drain the engine oil when the oil is **warm** as shown in Figure 27.
2. Remove the oil drain bolt and sealing washer and allow the oil to drain into a suitable container.
3. Replace engine oil with recommended type oil as listed in Table 5. Engine oil capacity is .63 quarts (.60 liters). **DO NOT** overfill.
4. Install drain bolt with sealing washer and tighten securely.

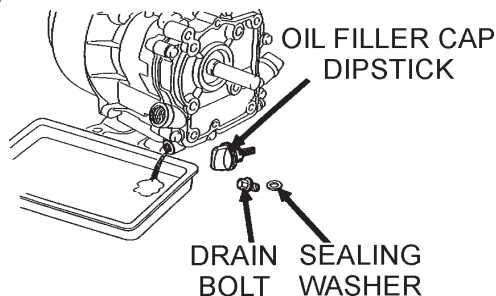

Figure 27. Engine Oil (Draining)

! DANGER - Combustion (Fire , Explosion)

DO NOT use gasoline as a cleaning solvent. The possibility exists of fire or explosion.

ENGINE AIR CLEANER

1. Remove the air cleaner cover and foam filter element as shown in Figure 28.
2. Tap the paper filter element (Figure 28) several times on a hard surface to remove dirt, or blow compressed air [not exceeding 30 psi (207 kPa, 2.1 kgf/cm²)] through the filter element from the air cleaner case side. **NEVER** brush off dirt. Brushing will force dirt into the fibers. Replace the paper filter element if it is excessively dirty.
3. Clean foam element in warm, soapy water or nonflammable solvent. Rinse and dry thoroughly. Dip the element in clean engine oil and completely squeeze out the excess oil from the element before installing.

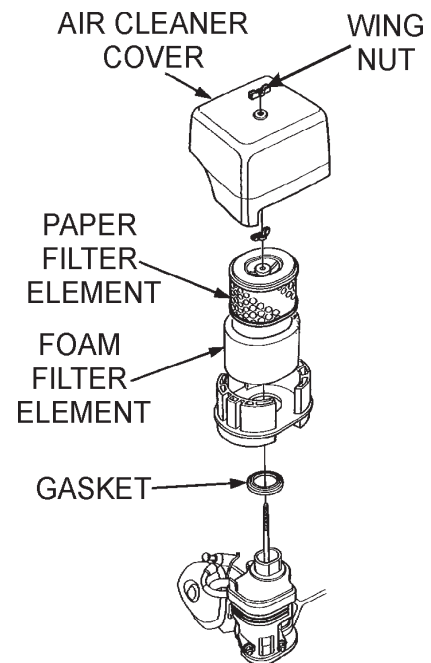

Figure 28. Engine Air Cleaner

PREPARATION FOR LONG-TERM STORAGE

Pump Storage

For storage of the pump for over 30 days, the following is required:

- Drain the fuel tank completely.
- Run the engine until the fuel is completely consumed.
- Completely drain used oil from the engine crankcase and fill with fresh clean oil, then follow the procedures described in the engine manual for engine storage.
- Remove the pump cover and clean inside of pump housing. Coat inside of pump housing with a light film of oil to reduce corrosion. A spray can of oil works well for this application.
- Cover suction and discharge ports with duct tape to prevent any foreign matter from falling into pump.
- Cover pump and engine with plastic covering or equivalent and store in a clean, dry place.

TABLE 8. ENGINE TROUBLESHOOTING

SYMPTOM	POSSIBLE PROBLEM	SOLUTION
Difficult to start		
Fuel is available but spark plug will not ignite. (Power available at high tension cable).	Ignition plug being bridge?	Check ignition system.
	Carbon deposit at ignition?	Clean or replace ignition.
	Short circuit due to defective insulators?	Replace insulators.
	Improper spark gap?	Set spark plug gap to the correct gap.
Fuel is available but spark plug will not ignite. (Power NOT available at high tension cable).	Short circuit at stop switch?	Check stop switch circuit. Replace stop switch if defective.
	Ignition coil defective?	Replace ignition coil.
Fuel is available and spark plug ignites (compression normal).	Muffler clogged with carbon deposits?	Clean or replace muffler.
	Mixed fuel quality is inadequate?	Check fuel to oil mixture.
	Fuel in use inadequate (water, dust)?	Flush fuel sytem and replace with fresh fuel.
	Air Cleaner clogged?	Clean or replace air cleaner.
Fuel is available and spark plug ignites (compression low).	Defective cylinder head gasket?	Tighten cylinder head bolts or replace head gasket.
	Cylinder worn?	Replace cylinder.
	Spark plug loose?	Tighen spark plug.
Operation not satisfactory		
Not enough power available (compression normal, no miss-firing).	Air cleaner clogged?	Clean or replace air cleaner.
	Air in fuel line?	Bleed (remove air) from fuel line.
	Fuel level in carbureator float chamber improper?	Adjust carbureator float
	Carbon deposits in cylinder?	Clean or replace cylinder
Not enough power available (compression normal, miss-firing).	Ignition coil defective?	Flush fuel sytem and replace with fresh fuel.
	Ignition plug often shorts?	Replace ignition wires, clean ignition.
	Fuel in use inadequate (water, dust)?	Flush fuel sytem and replace with fresh fuel.
Engine overheats.	Excessive carbon depostion in combustion chamber?	Clean or replace crankcase.
	Exhaust or muffler clogged with carbon.	Clean or replace muffler.
	Spark plug heat value incorrect?	Replace spark plug with correct type spark plug.

TROUBLESHOOTING

TABLE 8. ENGINE TROUBLESHOOTING (Continued)

SYMPTOM	POSSIBLE PROBLEM	SOLUTION
Operation not satisfactory		
Rotational speed fluctuates.	Governor adjustment improper?	Adjust governor to correct lever.
	Governor spring defective?	Clean or replace ignition.
	Fuel flow erratic?	Check fuel line.
	Air taken in through suction line?	Check suction line.
Recoil starter not working properly.	Dust in rotating part?	Clean recoil starter assembly.
	Spring spring failure?	Replace sprial spring.

TABLE 9. PUMP TROUBLESHOOTING

SYMPTOM	POSSIBLE PROBLEM	SOLUTION
Pump does not take on water.	Not enough priming water in the housing?	Add water to suction chamber.
	Engine speed too low?	Increase throttle.
	Strainer plugged?	Clean strainer.
	Suction hose damaged?	Replace or repair hose, and clamps
	Air leak at suction port?	Check that fittings are tight and properly sealed.
	Pump is located too high above water line?	Move pump closer to water.
	Debris collecting in pump housing?	Clean pump housing.
	Water leaking out weep hole between pump and engine?	Check condition of mechanical seal and gaskets, between pump end and engine housing.
	Valves not seated correctly?	Check that valves are seated correctly. Pour water in in suction chamber to help seal valves.
Pump does not prime correctly?	Check diaphragm for breaks or leaks.	
Pump takes in water, little or no discharge.	Engine speed too low?	Increase throttle speed.
	Suction strainer partially plugged?	Clean strainer.
Suction hose leaks at inlet.	Teflon Tape/Pipe Dope not used?	Apply teflon tape or pipe dope to NPT fittings.
	Hose diameter is too large?	Use same diameter on suction/discharge ports.
Discharge hose does not stay on coupling.	Pressure too high?	Check pressure, add additional clamp.
	Hose kinked or end blocked?	Check hose.

TABLE 9. PUMP TROUBLESHOOTING (Continued)

SYMPTOM	POSSIBLE PROBLEM	SOLUTION
Flow rate is slow.	Incorrect engine speed speed?	Increase engine speed.
	Piping is clogged or damaged?	Clean or replace piping.
	Clogged pump?	Clean pump well.
	Discharge line restricted or undersize?	Flush out piping or replace.
	Collapsible disc hose?	Replace with rigid or noncollapsible hose.
	Too many hose bends?	Straighten hose.
	Hose lines too long?	Shorten hose lines.
Pump runs but no fluid.	Faulty suction piping?	Replace piping.
	Pump located too far from fluid source?	Move pump closer to source.
	Gate valve closed?	Open gate valve.
	Clogged strainer?	Clean or replace strainer.
	Discharge height too high?	Lower the height.
Pump starts and stops pumping.	Leak in suction line?	Repair suction line.
	Leak in foot valve?	Repair or replace valve.
	Diaphragm has a crack or hole?	Replace diaphragm.
	Defective or clogged flapper valves?	Clean or replace flapper valves.
Excessive noise while pump is in operation.	Pump not secured properly?	Secure pump.
	restricted suction line?	Clean or correct restriction.
Water can be seen on top of diaphragm.	Diaphragm has crack or hole?	Replace diaphragm.
	Screw loose holding diaphragm?	Tighten screw.
Pump stalls repeatedly or stops for no apparent reason.	Discharge height is over 25 feet (7.62 meters) of head?	Lower height.
	Material jammed in pump well?	Clean out pump well.

EXPLANATION OF CODE IN REMARKS COLUMN

The following section explains the different symbols and remarks used in the Parts section of this manual. Use the help numbers found on the back page of the manual if there are any questions.

NOTICE

The contents and part numbers listed in the parts section are subject to change **without notice**. Multiquip does not guarantee the availability of the parts listed.

SAMPLE PARTS LIST

NO.	PART NO.	PART NAME	QTY.	REMARKS
1	12345	BOLT.....	1	INCLUDES ITEMS W/%
2%		WASHER, 1/4 IN.....		NOT SOLD SEPARATELY
2%	12347	WASHER, 3/8 IN.....	1	MQ-45T ONLY
3	12348	HOSE		A/R ...MAKE LOCALLY
4	12349	BEARING	1	S/N 2345B AND ABOVE

NO. Column

Unique Symbols — All items with same unique symbol

(@, #, +, %, or >) in the number column belong to the same assembly or kit, which is indicated by a note in the “Remarks” column.

Duplicate Item Numbers — Duplicate numbers indicate multiple part numbers, which are in effect for the same general item, such as different size saw blade guards in use or a part that has been updated on newer versions of the same machine.

NOTICE

When ordering a part that has more than one item number listed, check the remarks column for help in determining the proper part to order.

PART NO. Column

Numbers Used — Part numbers can be indicated by a number, a blank entry, or TBD.

TBD (To Be Determined) is generally used to show a part that has not been assigned a formal part number at the time of publication.

A blank entry generally indicates that the item is not sold separately or is not sold by Multiquip. Other entries will be clarified in the “Remarks” Column.

QTY. Column

Numbers Used — Item quantity can be indicated by a number, a blank entry, or A/R.

A/R (As Required) is generally used for hoses or other parts that are sold in bulk and cut to length.

A blank entry generally indicates that the item is not sold separately. Other entries will be clarified in the “Remarks” Column.

REMARKS Column

Some of the most common notes found in the “Remarks” Column are listed below. Other additional notes needed to describe the item can also be shown.

Assembly/Kit — All items on the parts list with the same unique symbol will be included when this item is purchased.

Indicated by:

“INCLUDES ITEMS W/(unique symbol)”

Serial Number Break — Used to list an effective serial number range where a particular part is used.

Indicated by:

“S/N XXXXX AND BELOW”

“S/N XXXX AND ABOVE”

“S/N XXXX TO S/N XXX”

Specific Model Number Use — Indicates that the part is used only with the specific model number or model number variant listed. It can also be used to show a part is NOT used on a specific model or model number variant.

Indicated by:

“XXXXX ONLY”

“NOT USED ON XXXX”

“Make/Obtain Locally” — Indicates that the part can be purchased at any hardware shop or made out of available items. Examples include battery cables, shims, and certain washers and nuts.

“Not Sold Separately” — Indicates that an item cannot be purchased as a separate item and is either part of an assembly/kit that can be purchased, or is not available for sale through Multiquip.

SUGGESTED SPARE PARTS

MQ-D2H/D3H DIAPHRAGM PUMP 1 TO 3 UNITS WITH HONDA GX120K1QX2 ENGINE

Qty.	P/N	Description
3	17210ZE0505	ELEMENT AIR CLEANER DUAL
3	9807955846	SPARK PLUG
1	17620ZH7023	CAP, FUEL WITH GASKET
1	28462ZH8003	ROPE STARTER
1	336030000	DIAPHRAGM 2-INCH
1	213200000	DIAPHRAGM 3-INCH
2	336007090	FLAP VALVE 2-INCH
2	335407090	FLAP VALVE 3-INCH
1	212400000	PLUG, 2 & 3-INCH FILL
1	212500000	PRIMING PLUG GASKET, 2 & 3-INCH
1	C23017000	STRAINER 2-INCH
1	168000000	STRAINER 3-INCH

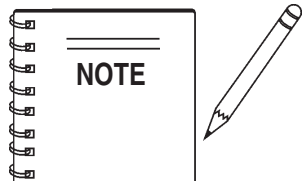

Part number on this Suggested Spare Parts List may super cede/replace the P/N shown in the text pages of this book.

NAME PLATE AND DECALS ASSY.

NAMEPLATE AND DECALS ASSY.

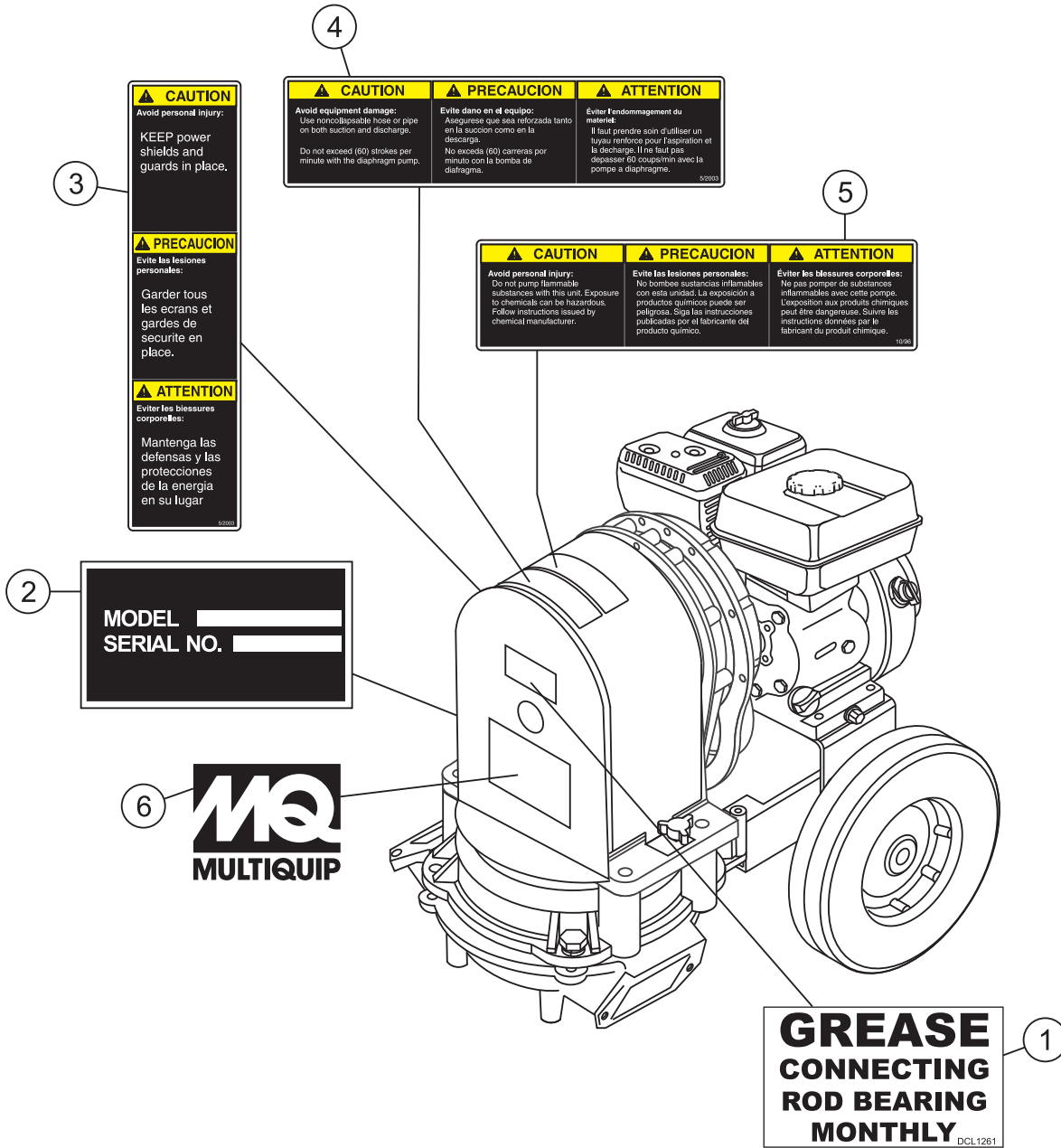

NAME PLATE AND DECALS ASSY.

NAMEPLATE AND DECALS ASSY.

<u>NO.</u>	<u>PART NO.</u>	<u>PART NAME</u>	<u>QTY.</u>	<u>REMARKS</u>
1	DCL1261	DECAL, GREASE MONTHLY	1	
2		DECAL, NAMEPLATE	1 CONTACT MQ PARTS DEPT
3	205901900	DECAL, CAUTION, KEEP GUARDS IN PLACE	1	
4	335425200	DECAL, CAUTION, AVOID EQUIPMENT DAMAGE	1	
5	205200200	DECAL, CAUTION, AVOID PERSONAL INJURY	1	
6	512910	DECAL, MQ LOGO	1	

MQD2H — WATERBOX AND FLAP VALVE ASSY.

WATERBOX AND FLAP VALVE ASSY. (2-INCH)

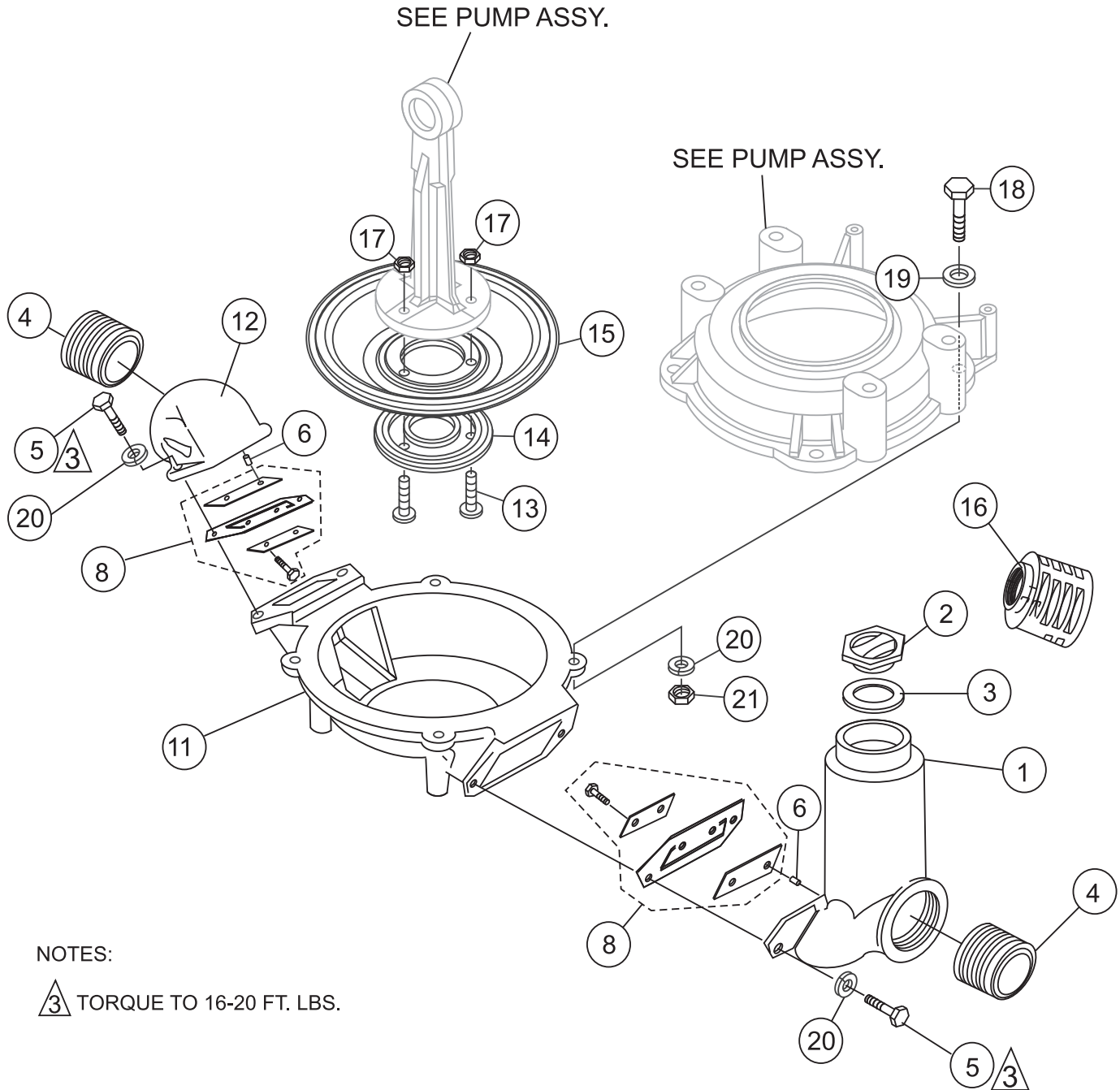

NOTES:

 TORQUE TO 16-20 FT. LBS.

MQD2H — WATERBOX AND FLAP VALVE ASSY.

WATERBOX AND FLAP VALVE ASSY. (2-INCH)

<u>NO.</u>	<u>PART NO.</u>	<u>PART NAME</u>	<u>QTY.</u>	<u>REMARKS</u>
1	336005001	SUCTION PRIMING CHAMBER	1	
2	212400000	PRIMING PLUG	1	
3	212500000	PRIMING PLUG GASKET	1	
4	316017000	NPT PIPE NIPPLES (PACK OF TWO)	1	
5	176601300	BOLT 1/2"-13 X 1-1/2"	4	
5	175900100	BOLT 3/8"-16 X 1-1/2"	4	
6	212100000	RETAINER PIN 1/8" X 3/8"	2	
8	336007090	FLAPPER VALVE ASSY	2	
11	336000101	PUMP WELL	1	
12	336005201	DISCHARGE PLATE	1	
13	176001100	CARRIAGE BOLT 3/8"-16 X 2-1/4"	3	
14	336009200	DIAPHRAGM RETAINER	1	
15	336030000	DIAPHRAGM	1	
16	C23017000	NPT STRAINER 3/8" HOLES	1	
17	178000000	NUT, HEX 3/8"-16	3	
18	176601600	BOLT 1/2"-13 X 2-1/4"	4	
19	179800200	FLAT WASHER 1/2"	4	
20	179800100	SPLIT LOCKWASHER 1/2"	8	
20	179300100	SPLIT LOCKWASHER 3/8"	8	
21	178200100	NUT 1/2"-13	4	

MQD2H —PUMP ASSY.

PUMP ASSY. (2-INCH)

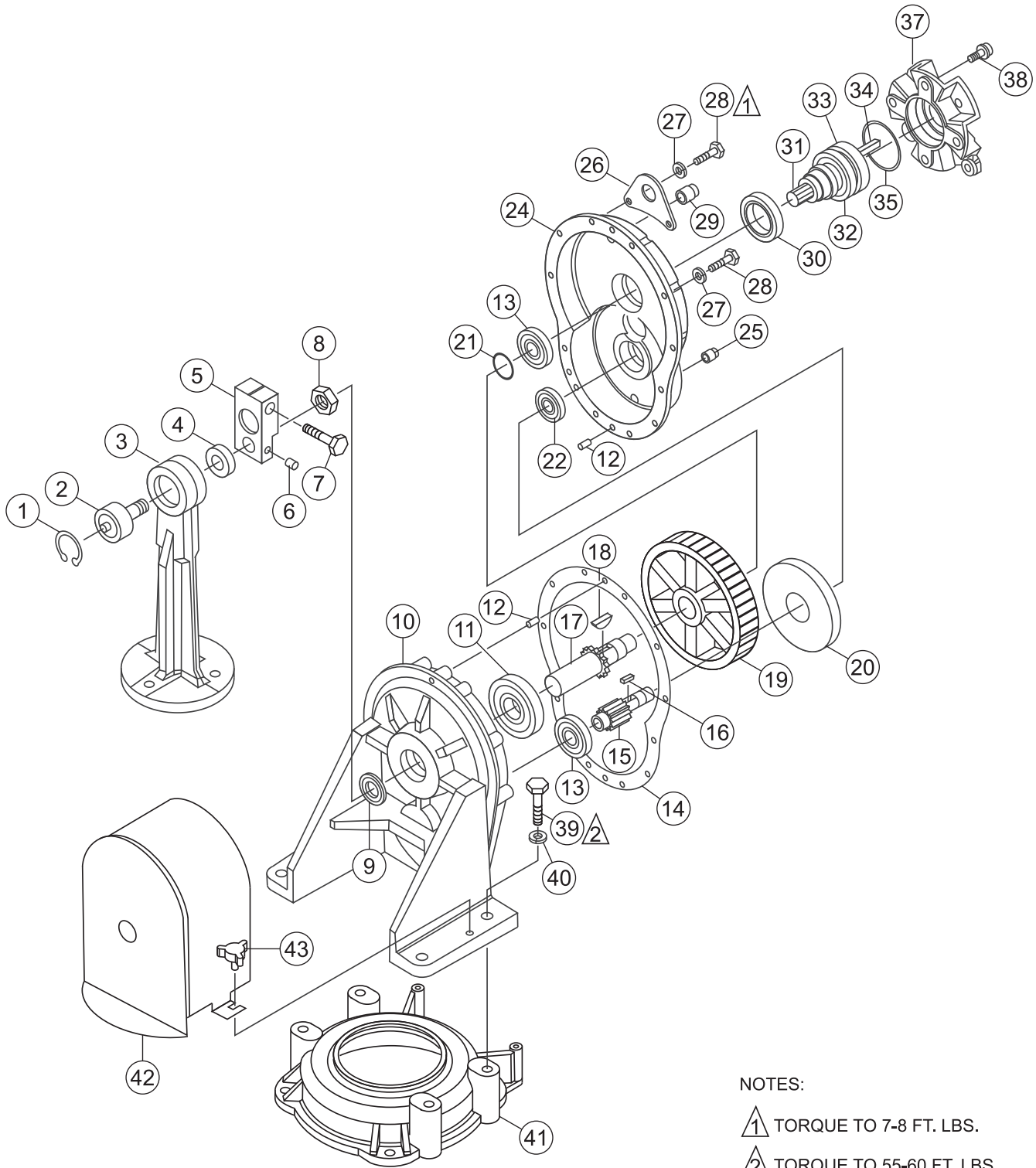

MQD2H —PUMP ASSY.

PUMP ASSY. (2-INCH)

<u>NO.</u>	<u>PART NO.</u>	<u>PART NAME</u>	<u>QTY.</u>	<u>REMARKS</u>
1	336019100	INTERNAL RETAINING RING 1-1/2"	1	
2	336019000	PLUNGER BEARING	1	INCLUDES ITEMS W/#
3	336009001	PLUNGER ARM	1	
4	180103000	SPACER 5/8" X 1-1/16"	1	
5	336009401	CRANK	1	
6	173800100	SOCKET SET SCREW 5/16"-18 X 1/2"	1	
7	176601800	BOLT 1/2"-13 X 2-3/4"	1	
8#		LOCKNUT 3/4" -16	1	
9	214800000	OIL SEAL	1	
10	335409001	GEAR BOX OUTPUT HALF	1	
11	335419000	OUTPUT BALL BEARING #6307	1	
12	171700200	DOWEL PIN 1/4" X 3/4"	2	
13	335419100	INTERMEDIATE BALL BEARING #6304	2	
14	335430000	GASKET	1	
15	335412100	IDLER PINION SHAFT	1	
16	215700000	WOODRUFF KEY #406 1/8" X 3/4"	1	
17	335414001	OUTPUT SHAFT	1	
18	214100000	WOODRUFF KEY #1008 5/16" X 1"	1	
19	335412000	OUTPUT GEAR	1	
20	214900000	INTERNAL SPUR GEAR	1	
21	180606400	EXTERNAL RETAINING RING 1-1/8"	1	
22	335419200	IDLER BALL BEARING #6302	1	
24	335409101	GEAR BOX INPUT HALF	1	
25	176700200	NPT PIPE PLUG 1/4"	2	
26	335410600	LIFT BRACKET	1	
27	178800100	LOCK WASHER 1/4"	12	
28	171800400	BOLT 1/4"-20 X 7/8"	12	
29	176700100	NPT PIPE PLUG 1/2"	1	
30	335419400	INPUT PINION BALL BEARING OPEN #6007	1	
31	335412200	INPUT PINION	1	
32	214800100	OIL SEAL, INPUT PINION	1	
33	335419300	INPUT PINION BALL BEARING SEALED #6007	1	
34	151700100	KEY 3/16" X 3/16" X 1-1/2"	1	
35	218100500	O-RING #143 BUNA N	1	
37	335409301	ADAPTER (GASOLINE ENGINE)	1	
38	174500200	FLANGE SCREW 5/16"-18 X 3/4"	4	
39	176601300	BOLT 1/2"-13 X 1-1/2"	2	
39	175900100	BOLT 3/8"-16 X 1-1/2"	2	
40	179800100	SPLIT LOCKWASHER 1/2"	2	
40	179300100	SPLIT LOCKWASHER 3/8"	2	
41	336002001	PUMP BASE	1	
42	335410300	PLUNGER GUARD	1	
43	171601000	KNOB 1/4"-20 X 1/2"	2	

MQD2H —HANDLE, ENGINE, AND WHEEL ASSY.

HANDLE, ENGINE AND WHEEL ASSY. (2-INCH)

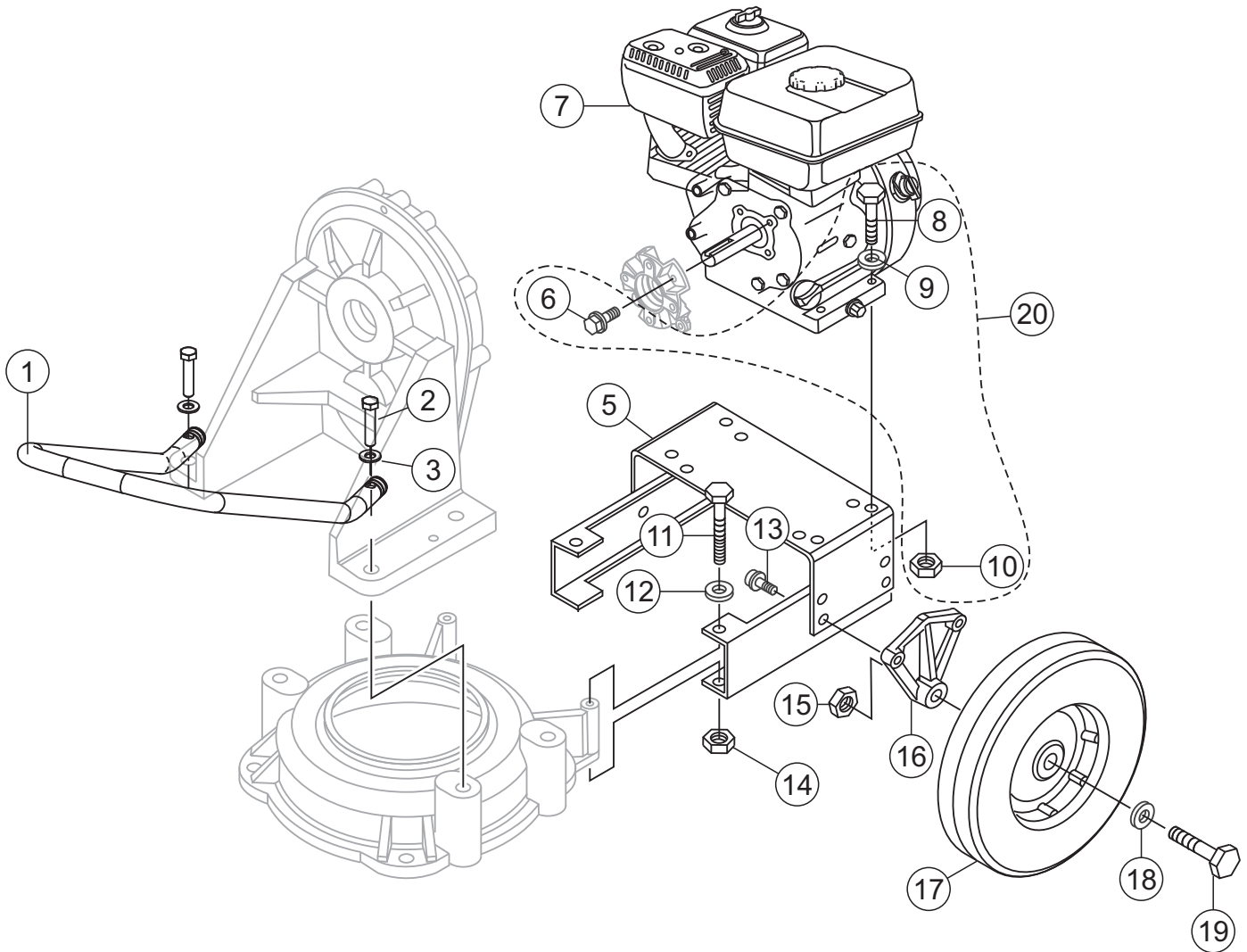

MQD2H —HANDLE, ENGINE, AND WHEEL ASSY.

HANDLE, ENGINE AND WHEEL ASSY. (2-INCH)

<u>NO.</u>	<u>PART NO.</u>	<u>PART NAME</u>	<u>QTY.</u>	<u>REMARKS</u>
1	335411690	HANDLE	1	REPLACES 215200000
2	13178	BOLT 1/2"-13 X 2-1/4"	2	REPLACES 176601300 & 175900100
3	0447	FLAT WASHER 1/2"	2	REPLACES 179800100 & 179300100
5	335410800	ENGINE MOUNT	1	
6#	TBD	BOLT	4	
7	163000700	HONDA GX120 ENGINE	1	
8#	TBD	BOLT	4	
9#	TBD	WASHER	4	
10#	TBD	NUT	4	
11	173401300	BOLT 1/4"-20 X 3"	2	
12	178900000	SAE WASHER 1/4"	2	
13	174500200	FLANGE BOLT 5/16-18 X 3/4"	4	
14	176600000	FLANGE NUT 1/4"-20	2	
15	178202000	NUT 5/8"-18	2	
16	335410900	WHEEL BRACKET	2	
17	166300000	WHEEL	2	
18	179900000	WASHER 5/8"	2	
19	176900000	BOLT 5/8"-18 X 4"	2	
20	335A42090	KIT, HARDWARE, GASOLINE ENGINE ADAPTER (PACK OF 4)	1	INCLUDES ITEMS W/#

MQD3H — WATERBOX AND FLAP VALVE ASSY.

WATERBOX AND FLAP VALVE ASSY. (3-INCH)

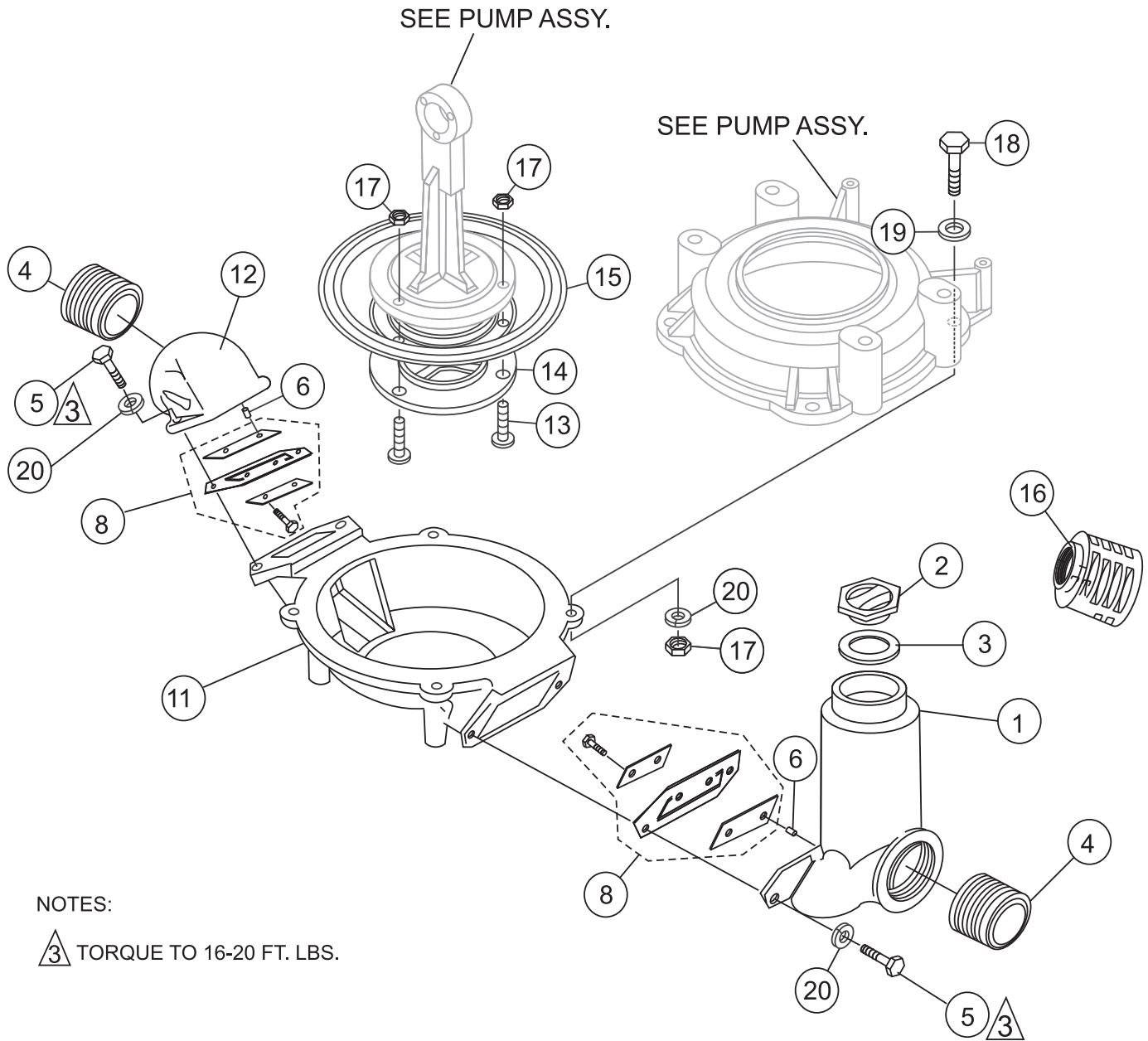

MQD3H —WATERBOX AND FLAP VALVE ASSY.

WATERBOX AND FLAP VALVE ASSY. (3-INCH)

<u>NO.</u>	<u>PART NO.</u>	<u>PART NAME</u>	<u>QTY.</u>	<u>REMARKS</u>
1	212300001	SUCTION PRIMING CHAMBER	1	
2	212400000	PRIMING PLUG	1	
3	212500000	PRIMING PLUG GASKET	1	
4	327017000	NPT PIPE NIPPLES (PACK OF TWO)	1	
5	176601300	BOLT 1/2"-13 X 1-1/2"	4	
6	212100000	RETAINER PIN 1/8" X 3/8"	2	
8	335407090	FLAPPER VALVE ASSY	2	
11	212000001	PUMP WELL	1	
12	213100001	DISCHARGE PLATE	1	
13	176601500	CARRIAGE BOLT 1/2"-13 x 2"	3	
14	213300000	DIAPHRAGM RETAINER	1	
15	213200000	DIAPHRAGM	1	
16	168000000	NPT STRAINER 3/8" HOLES	1	
17	178200100	NUT, HEX 1/2"-13	5	
18	176601600	BOLT 1/2"-13 X 2-1/4"	2	
19	179800200	FLAT WASHER 1/2"	2	
20	179800100	SPLIT LOCKWASHER 1/2"	6	

MQD3H — PUMP ASSY.

PUMP ASSY. (3-INCH)

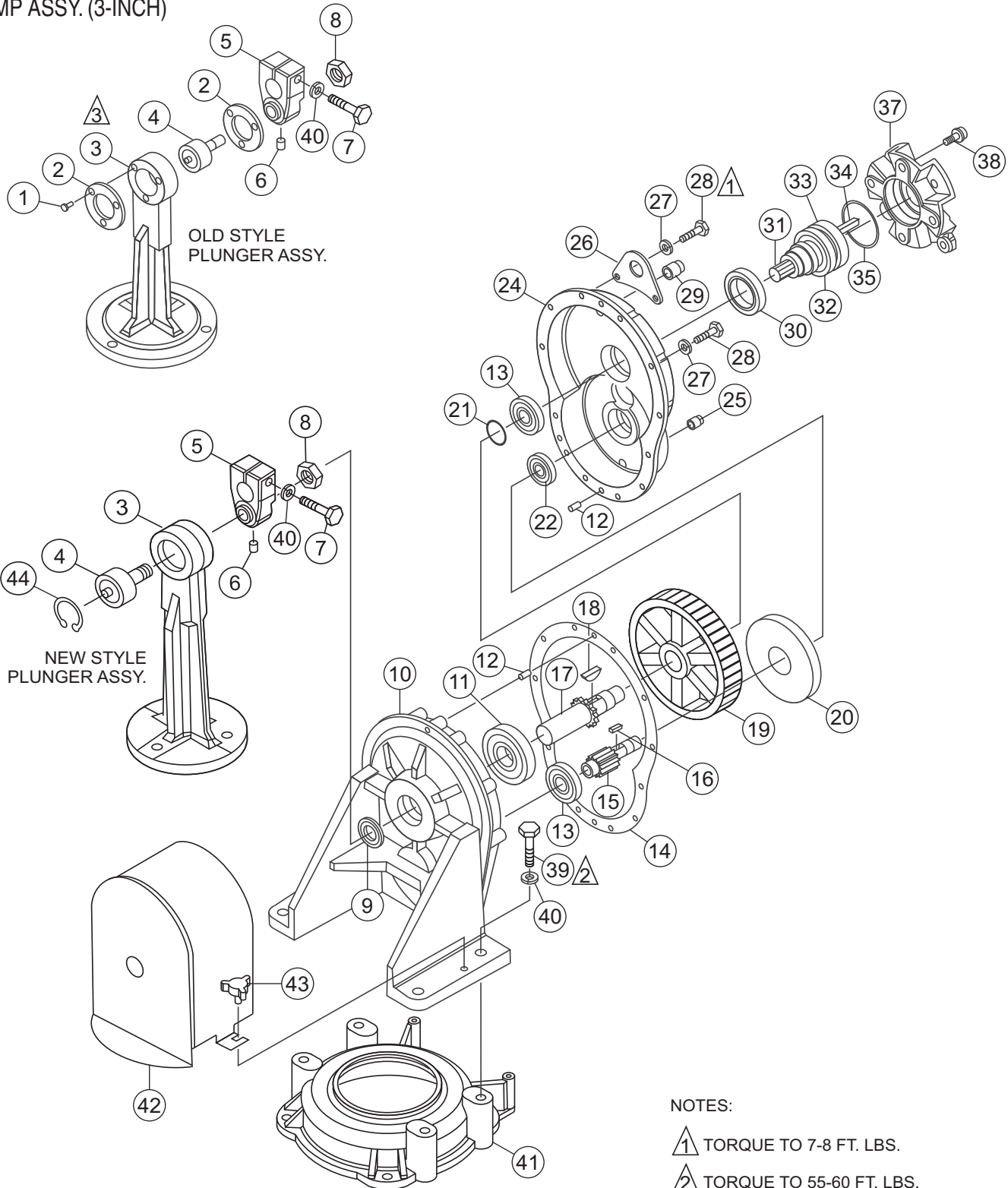

NOTES:

- ▲ TORQUE TO 7-8 FT. LBS.
- ▲ TORQUE TO 55-60 FT. LBS.
- ▲ OLD STYLE PLUNGER ARM, ITEM 3, NO LONGER AVAILABLE. IF REPLACEMENT IS REQUIRED, ORDER NEW STYLE PLUNGER ASSY. PARTS.

MQD3H — PUMP ASSY.

PUMP ASSY. (3-INCH)

<u>NO.</u>	<u>PART NO.</u>	<u>PART NAME</u>	<u>QTY.</u>	<u>REMARKS</u>
1	170400200	FLAT HD MACH SCHREW #10-32 X 1/2"	6	OLD STYLE PLUNGER
2	213600000	BEARING RETAINER	2	OLD STYLE PLUNGER
3		PLUNGER ARM	1	NO LONGER AVAILABLE
3	213400001	PLUNGER ARM	1	NEW STYLE PLUNGER
4	213800090	PLUNGER BEARING	1	REPLACES P/N 213800000
5	214000001	CRANK	1	
6	173800100	SOCKET SET SCREW 5/16"-18 X 1/2"	1	
7	176601800	BOLT 1/2"-13 X 2-3/4"	1	
8	178401000	LOCKNUT 3/4" -16	1	
9	214800000	OIL SEAL	1	
10	335409001	GEAR BOX OUTPUT HALF	1	
11	335419000	OUTPUT BALL BEARING #6307	1	
12	171700200	DOWEL PIN 1/4" X 3/4"	2	
13	335419100	INTERMEDIATE BALL BEARING #6304	2	
14	335430000	GASKET	1	
15	335412100	IDLER PINION SHAFT	1	
16	215700000	WOODRUFF KEY #406 1/8" X 3/4"	1	
17	335414000	OUTPUT SHAFT	1	
18	214100000	WOODRUFF KEY #1008 5/16" X 1"	1	
19	335412000	OUTPUT GEAR	1	
20	214900000	INTERNAL SPUR GEAR	1	
21	180606400	EXTERNAL RETAINING RING 1-1/8"	1	
22	335419200	IDLER BALL BEARING #6302	1	
24	335409101	GEAR BOX INPUT HALF	1	
25	176700200	NPT PIPE PLUG 1/4"	2	
26	335410600	LIFT BRACKET	1	
27	178800100	LOCK WASHER 1/4"	12	
28	171800400	BOLT 1/4"-20 X 7/8"	12	
29	176700100	NPT PIPE PLUG 1/2"	1	
30	335419400	INPUT PINION BALL BEARING OPEN #6007	1	
31	335412200	INPUT PINION	1	
32	214800100	OIL SEAL, INPUT PINION	1	
33	335419300	INPUT PINION BALL BEARING SEALED #6007	1	
34	151700100	KEY 3/16" X 3/16" X 1-1/2"	1	
35	218100500	O-RING #143 BUNA N	1	
37	335409301	ADAPTER (GASOLINE ENGINE)	1	
38	174500200	FLANGE SCREW 5/16"-18 X 3/4"	4	
39	176601300	BOLT 1/2"-13 X 1-1/2"	4	
40	179800100	SPLIT LOCKWASHER 1/2"	5	
41	335400101	PUMP BASE	1	
42	335410300	PLUNGER GUARD	1	
43	171601000	KNOB 1/4"-20 X 1/2"	2	
44	335019000	RETAINER RING	1	NEW STYLE PLUNGER

MQD3H — HANDLE, ENGINE, AND WHEEL ASSY.

HANDLE, ENGINE AND WHEEL ASSY. (3-INCH)

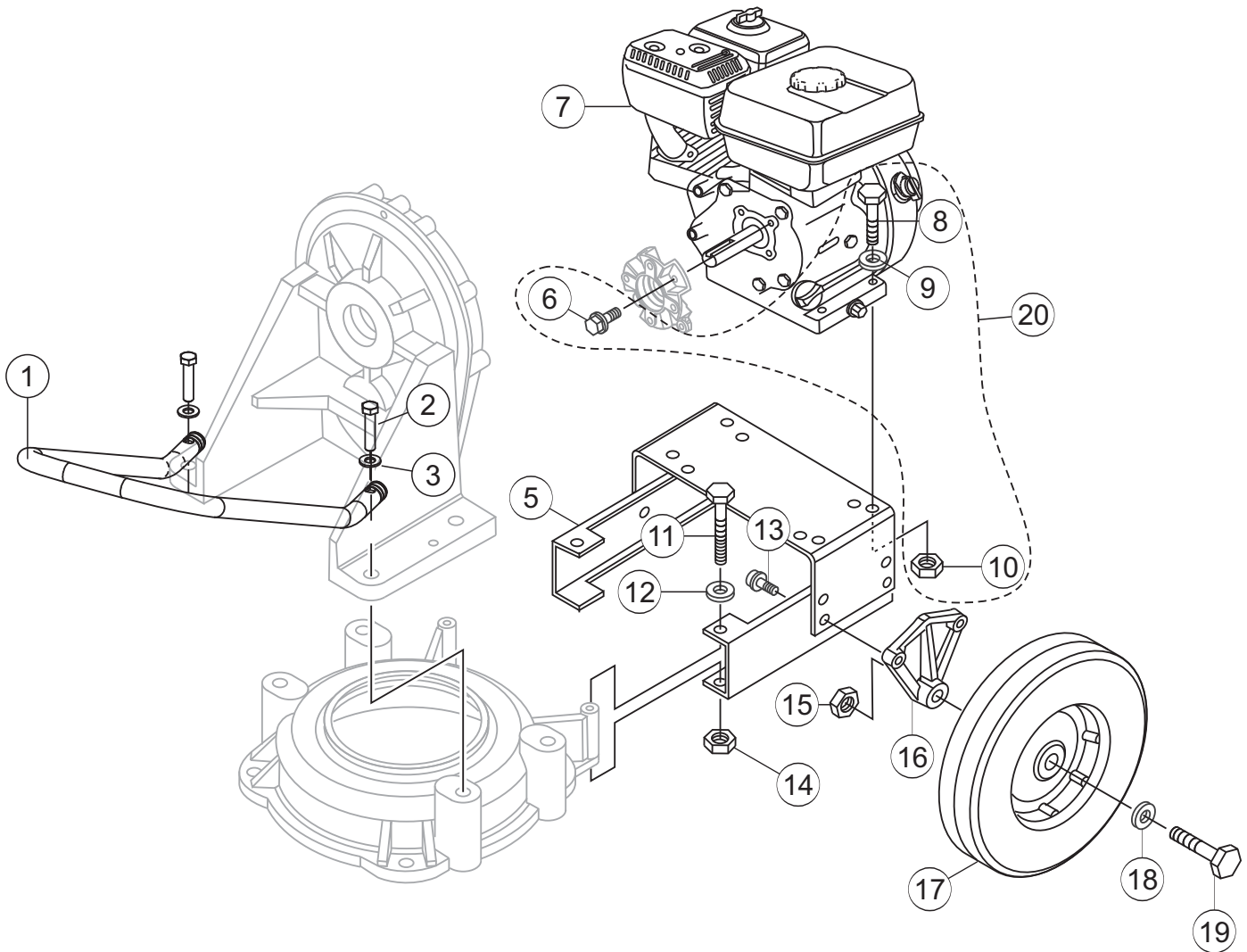

MQD3H — HANDLE, ENGINE, AND WHEEL ASSY.

HANDLE, ENGINE AND WHEEL ASSY. (3-INCH)

<u>NO.</u>	<u>PART NO.</u>	<u>PART NAME</u>	<u>QTY.</u>	<u>REMARKS</u>
1	335411690	HANDLE	1	REPLACES 215200000
2	13178	BOLT 1/2"-13 X 2-1/4"	2	REPLACES 176601600
3	0447	FLAT WASHER 1/2"	2	REPLACES 179800200
5	335410800	ENGINE MOUNT	1	
6#	TBD	BOLT	4	
7	163000700	HONDA GX120 ENGINE	1	
8#	TBD	BOLT	4	
9#	TBD	WASHER	4	
10#	TBD	NUT	4	
11	173401300	BOLT 1/4"-20 X 3"	2	
12	178900000	SAE WASHER 1/4"	2	
13	174500200	FLANGE BOLT 5/16-18 X 3/4"	4	
14	176600000	FLANGE NUT 1/4"-20	2	
15	178202000	NUT 5/8"-18	2	
16	335410900	WHEEL BRACKET	2	
17	166300000	WHEEL	2	
18	179900000	WASHER 5/8"	2	
19	176900000	BOLT 5/8"-18 X 4"	2	
20	335A42090	KIT, HARDWARE, GASOLINE ENGINE ADAPTER (PACK OF 4)	1	INCLUDES ITEMS W/#

HONDA GX120K1QX2 ENGINE — AIR CLEANER ASSY.

AIR CLEANER ASSY.

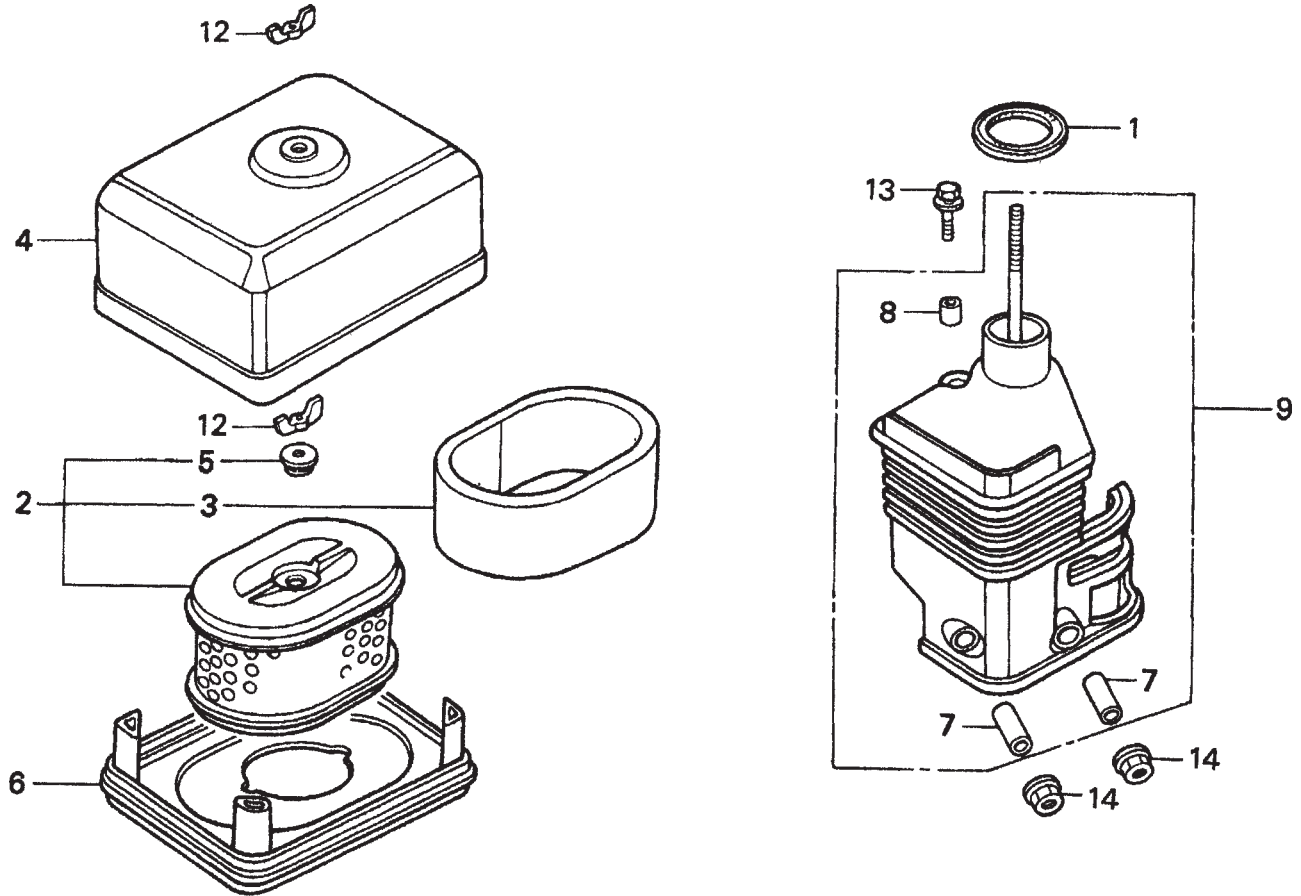

HONDA GX120K1QX2 ENGINE — AIR CLEANER ASSY.

AIR CLEANER ASSY.

<u>NO.</u>	<u>PART NO.</u>	<u>PART NAME</u>	<u>QTY.</u>	<u>REMARKS</u>
1	16271ZE1000	GASKET, ELBOW	1	
2	17210ZE0505	ELEMENT, AIR CLEANER (DUAL)	1	INCLUDES ITEMS W/*
3*	17218ZE0505	FILTER, OUTER	1	
4	17230ZE0820	COVER, AIR CLEANER (DUAL)	1	
5*	17232891000	GROMMET, AIR CLEANER	1	
7#	17238ZE0010	COLLAR, AIR CLEANER	2	
8#	17239ZE1000	COLLAR B, AIR CLEANER	1	
9	17410ZE0030	ELBOW, AIR CLEANER	1	INCLUDES ITEMS W/#
12	90325044000	WINGNUT, TOOL BOX SETTING	2	
13	957010602000	BOLT, FLANGE 6X20	1	
14	9405006000	NUT, FLANGE 6MM	2	

HONDA GX120K1QX2 ENGINE — CAMSHAFT ASSY.

CAMSHAFT ASSY.

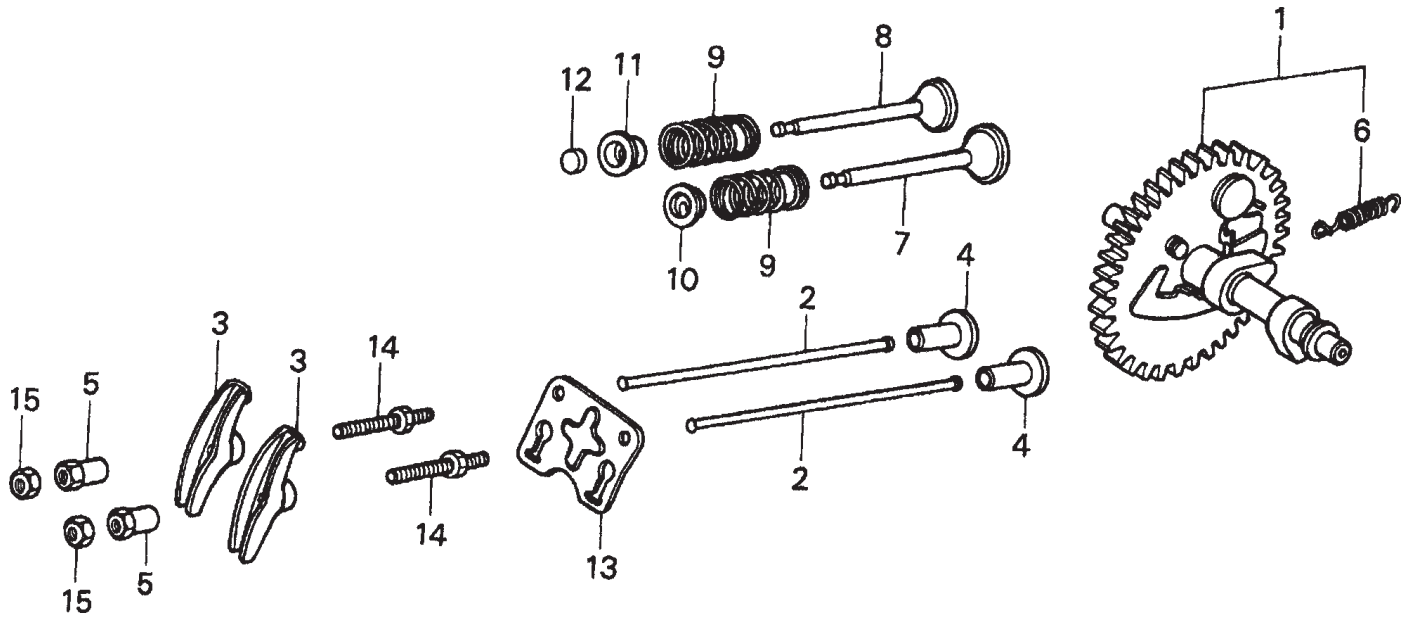

HONDA GX120K1QX2 ENGINE — CAMSHAFT ASSY.

CAMSHAFT ASSY.

<u>NO.</u>	<u>PART NO.</u>	<u>PART NAME</u>	<u>QTY.</u>	<u>REMARKS</u>
1	14100ZE0812	CAMSHAFT ASSEMBLY	1	INCLUDES ITEMS W/*
2	14410ZE0010	ROD, PUSH	2	
3	14431ZE1000	ARM, VALVE ROCKER	2	
4	14441ZE1010	LIFTER, VALVE	2	
5	14451ZE1013	PIVOT, ROCKER ARM	2	
6*	14568ZE1000	SPRING, WEIGHT RETURN	1	
7	14711ZF0010	VALVE, IN.	1	
8	14721ZF0000	VALVE, EX.	1	
9	14751ZF1000	SPRING, VALVE	2	
10	14771ZE1000	RETAINER, IN. VALVE SPRING	1	
11	14773ZE1000	RETAINER, EX. VALVE SPRING	1	
12	14781ZE1000	ROTATOR, VALVE	1	
13	14791ZE0010	PLATE, PUSH ROD GUIDE	1	
14	90012ZE0010	BOLT, PIVOT 8MM	2	
15	90206ZE1000	NUT, PIVOT ADJ.	2	

HONDA GX120K1QX2 ENGINE — CARBURETOR ASSY.

CARBURETOR ASSY.

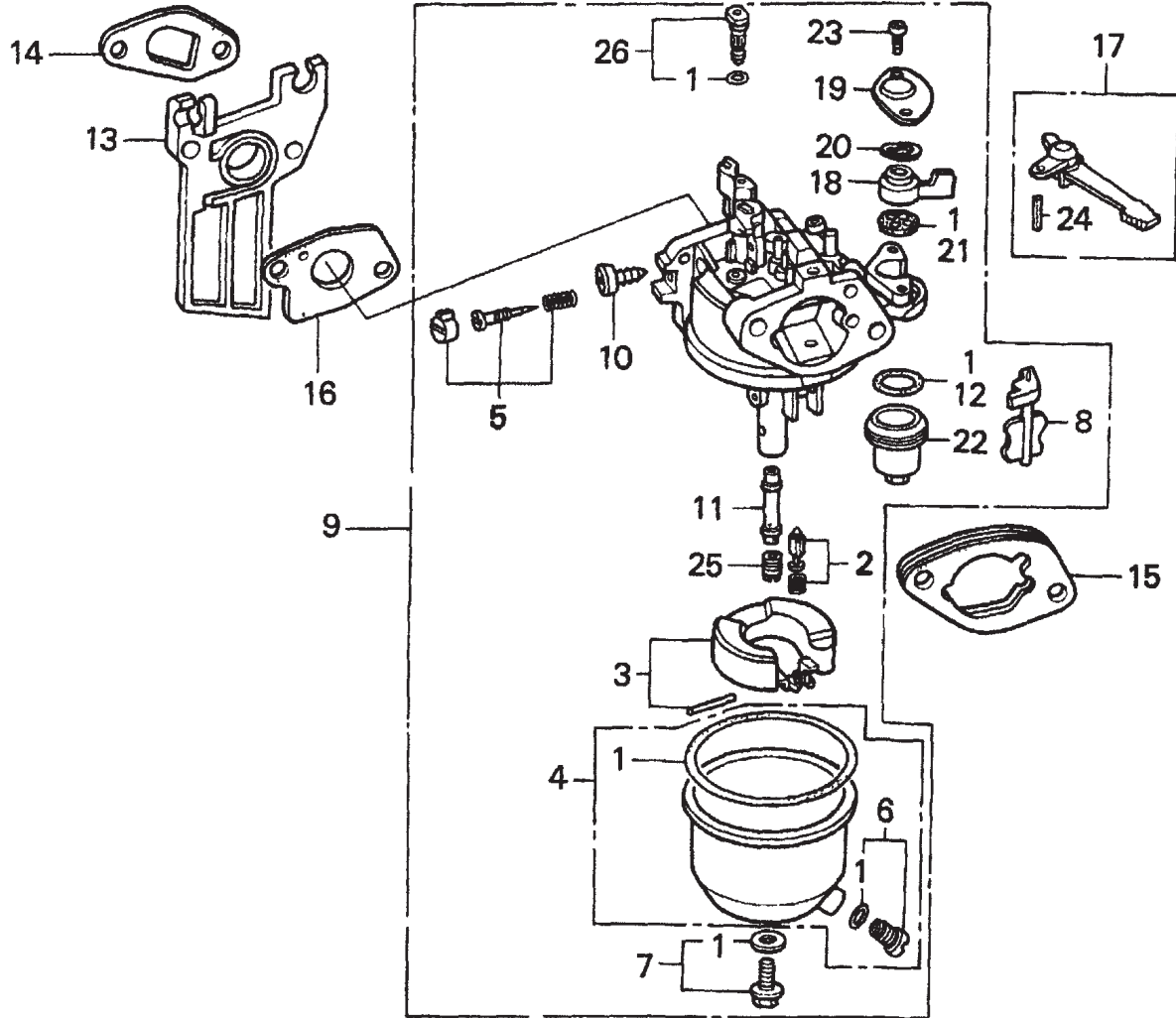

HONDA GX120K1QX2 ENGINE — CARBURETOR ASSY.

CARBURETOR ASSY.

<u>NO.</u>	<u>PART NO.</u>	<u>PART NAME</u>	<u>QTY.</u>	<u>REMARKS</u>
1*	16010ZE1812	GASKET SET	1	
2*	16011ZE0005	VALVE SET, FLOAT	1	
3*	16013ZE0005	FLOAT SET	1	
4*	16015ZE1811	CHAMBER SET, FLOAT	1	
5*	16016ZH7W01	SCREW SET	1	
6*	16024ZE1811	SCREW SET, DRAIN	1	
7*	16028ZE0005	SCREW SET B	1	
8*	16044ZE0005	CHOKE SET	1	
9	16100ZH7W51	CARBURETOR ASSEMBLY, BE60B B.....	1	INCLUDES ITEMS W/*
10*	16124ZE0005	SCREW, THROTTLE STOP	1	
11*	16166ZH7W50	NOZZLE, MAIN	1	
12*	16173001004	GASKET, FUEL STRAINER CUP	1	
13	16211ZE0000	INSULATOR, CARBURETOR	1	
14	16212ZH7800	GASKET, INSULATOR	1	
15	16220ZE1020	SPACER, CARBURETOR	1	
16	16221ZH8801	GASKET, CARBURETOR	1	
17	16610ZE1000	LEVER, CHOKE (STANDARD)	1	INCLUDES ITEMS W/+
18*	16953ZE1812	LEVER, VALVE	1	
19*	16954ZE1811	PLATE, LEVER SETTING	1	
20*	16956ZE1811	SPRING, VALVE LEVER	1	
21*	16957ZE1812	GASKET, VALVE	1	
22*	16967ZE0811	CUP, FUEL STRAINER	1	
23*	93500030080G	SCREW, PAN (3 X 6)	2	
24#	9430520122	PIN, SPRING (2 X 12)	1	
25	99101ZH80550	JET, MAIN (#55) (OPTIONAL)	1	
25	99101ZH80580	JET, MAIN (#58) (OPTIONAL)	1	
25*	99101ZH80600	JET, MAIN (#60)	1	
26*	99204ZE00350	JET, SET, PILOT (#35)	1	

HONDA GX120K1QX2 ENGINE — CONTROL ASSY.

CONTROL ASSY.

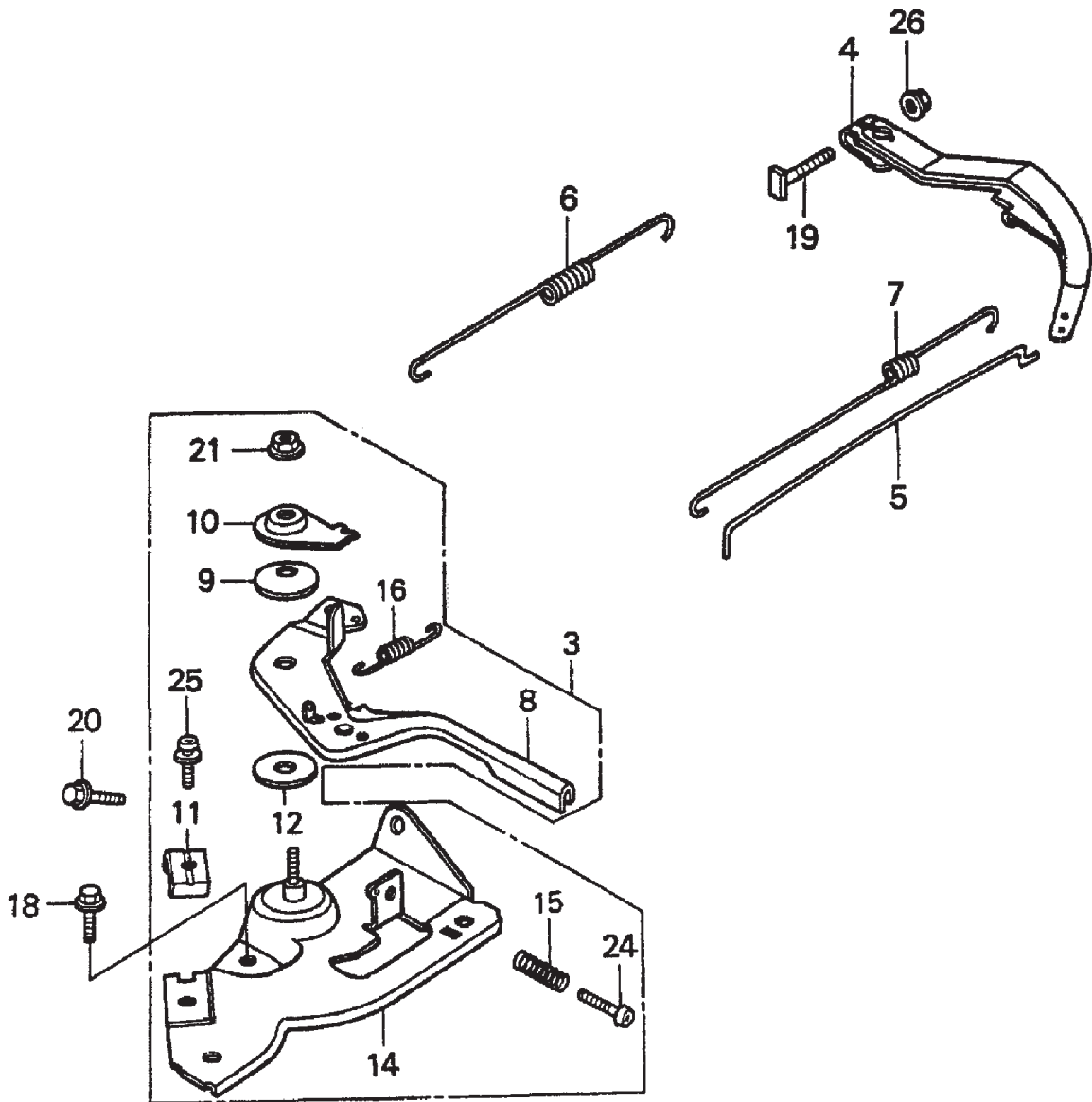

HONDA GX120K1QX2 ENGINE — CONTROL ASSY.

CONTROL ASSY.

<u>NO.</u>	<u>PART NO.</u>	<u>PART NAME</u>	<u>QTY.</u>	<u>REMARKS</u>
3	16500ZH7820	CONTROL ASSEMBLY (REMOTE)	1	INCLUDES ITEMS W/#
4	16551ZE0010	ARM, GOVERNOR	1	
5	16555ZE0000	ROD, GOVERNOR	1	
6	16561ZE0020	SPRING, GOVERNOR	1	
7	16562ZE0020	SPRING, THROTTLE RETURN	1	
8#	16571ZH7000	LEVER, CONTROL	1	
9#	16574ZE1000	SPRING, LEVER	1	
10#	16575ZH8000	WASHER, CONTROL LEVER	1	
11#	16576891000	HOLDER, CABLE		
12#	16578ZE1000	SPACER, CONTROL LEVER	1	
14#	16580ZH7810	BASE CONTROL	1	
15#	16584883300	SPRING, CONTROL ADJUSTING	1	
16#	16592ZE1810	SPRING, CABLE RETURN		
18	90013883000	BOLT, FLANGE 6X12 (CT200)	1	
19	90015ZE5010	BOLT, GOVERNOR ARM	1	
20	90022888010	BOLT, FLANGE 6X20 (CT200)	1	
21#	90114SA0000	NUT, SELF- LOCK 6MM	1	
24#	93500050250H	SCREW, PAN 5X25	1	
25#	93500050160A	SCREW, PAN	1	
26	9405006000	NUT, FLANGE 6MM	1	

HONDA GX120K1QX2 ENGINE — CRANKCASE COVER ASSY.

CRANKCASE COVER ASSY.

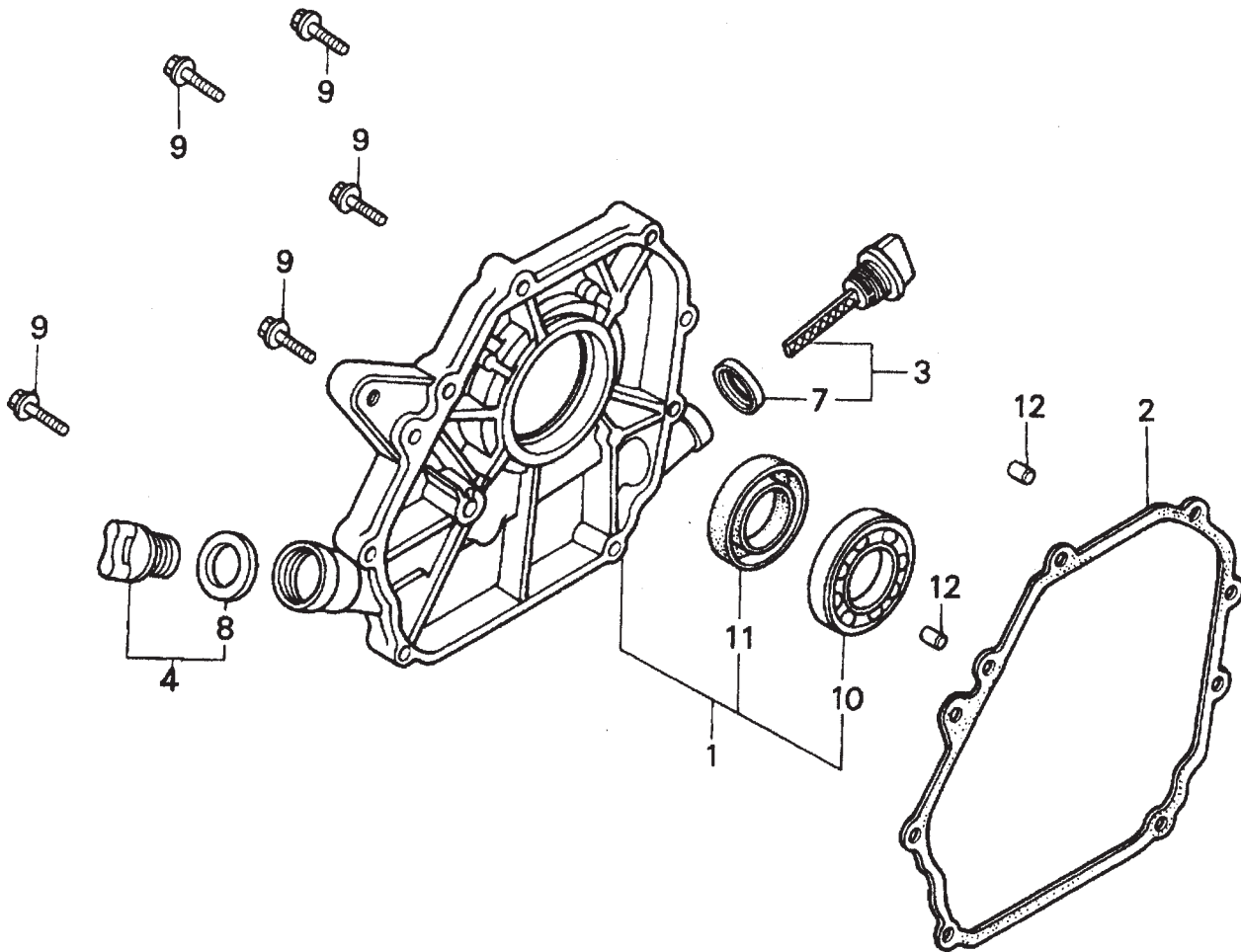

HONDA GX120K1QX2 ENGINE — CRANKCASE COVER ASSY.

CRANKCASE COVER ASSY.

<u>NO.</u>	<u>PART NO.</u>	<u>PART NAME</u>	<u>QTY.</u>	<u>REMARKS</u>
1	11300ZE0640	COVER ASSEMBLY, CRANKCASE (W- TYPE).....	1	INCLUDES ITEMS W/*
2	11381ZH7800	GASKET, CASE COVER	1	
3	15600ZE1003	CAP ASSEMBLY, OIL FILLER	1	INCLUDES ITEMS W/#
4	15600ZG4003	CAP ASSEMBLY, OIL FILLER	1	INCLUDES ITEMS W/+
7#	15625ZE1003	GASKET, OIL FILLER CAP	1	
8+	15625ZE1003	GASKET, OIL FILLER CAP	1	
9	90015883000	BOLT, FLANGE 6X28	7	
10*	91001878003	BEARING, RADIAL BALL	1	
11*	91203ZE0003	OIL SEAL 22X41X6	1	
12	9430108140	PIN A, DOWEL 8X14	2	

HONDA GX120K1QX2 ENGINE — CRANKSHAFT ASSY.

CRANKSHAFT ASSY.

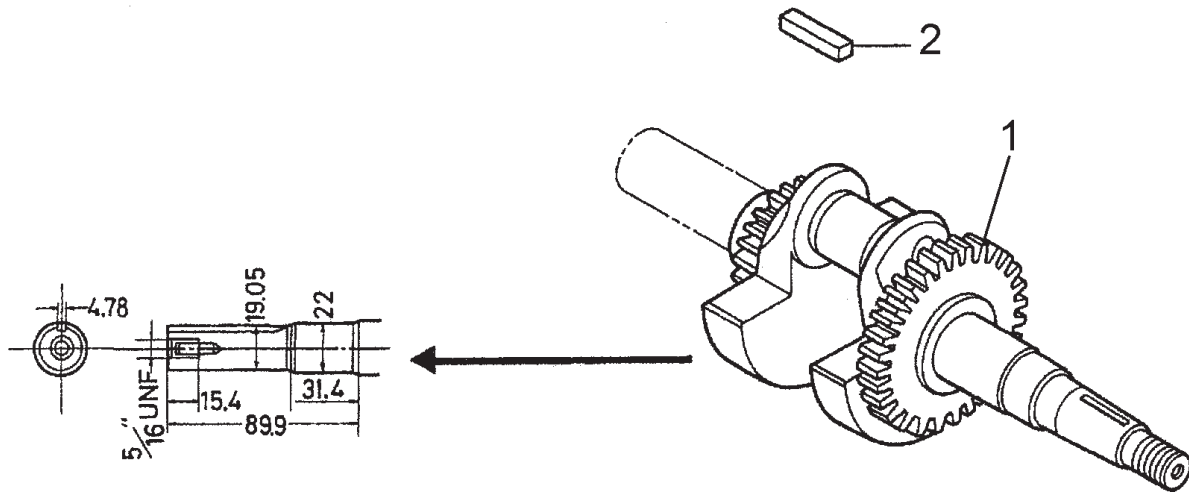

HONDA GX120K1QX2 ENGINE — CRANKSHAFT ASSY.

CRANKSHAFT ASSY.

<u>NO.</u>	<u>PART NO.</u>	<u>PART NAME</u>	<u>QTY.</u>	<u>REMARKS</u>
1	13310ZE0601	CRANKSHAFT, H-TYPE	1	
2	90745ZE1600	KEY 4.78 X4.78X38	1	

HONDA GX120K1QX2 ENGINE — CYLINDER BARREL ASSY.

CYLINDER BARREL ASSY.

<u>NO.</u>	<u>PART NO.</u>	<u>PART NAME</u>	<u>QTY.</u>	<u>REMARKS</u>
2	120A0ZH7810	CYLINDER ASSEMBLY (OIL ALERT)	1	INCLUDES ITEMS W/*
3	15510ZE1033	SWITCH ASSEMBLY, OIL LEVEL	1	
4	16510ZE1000	GOVERNOR ASSEMBLY	1	INCLUDES ITEMS W/#
5#	16511ZE1000	WEIGHT, GOVERNOR	2	
6#	16512ZE1000	HOLDER, GOVERNOR WEIGHT	1	
7#	16513ZE1000	PIN, GOVERNOR WEIGHT	2	
8	16531ZE1000	SLIDER, GOVERNOR	1	
9	16541ZE1000	SHAFT, GOVERNOR ARM	1	
10	90131ZE1000	BOLT, DRAIN PLUG	2	
11	90451ZE1000	WASHER, THRUST 6mm	1	
12	90601ZE1000	WASHER, DRAIN PLUG 10.2mm	2	
13	90602ZE1000	CLIP, GOVERNOR HOLDER	1	
14*	91001878003	BEARING, RADIAL BALL 62/22	1	
15*	91202ZE6003	OIL SEAL 22X35X6	1	
16	91353671003	O- RING 13.5X1.5 (ARAI)	1	
17	9405010000	NUT, FLANGE 10mm	1	
18	9410106800	WASHER, PLAIN 6mm	2	
19	9425108000	PIN, LOCK 8mm	1	
20	957010601200	BOLT, FLANGE 6X12	2	

HONDA GX120K1QX2 ENGINE — CYLINDER HEAD ASSY.

CYLINDER HEAD ASSY.

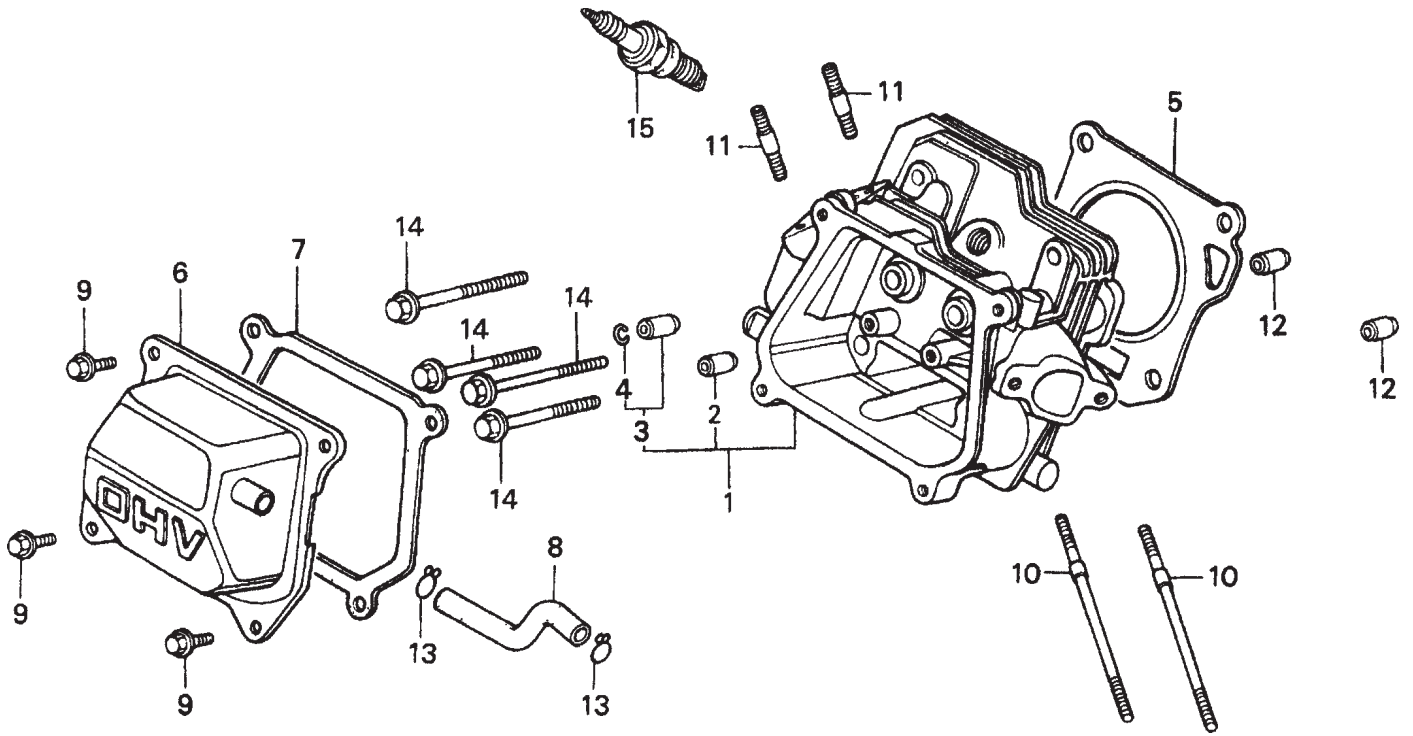

HONDA GX120K1QX2 ENGINE — CYLINDER HEAD ASSY.

CYLINDER HEAD ASSY.

<u>NO.</u>	<u>PART NO.</u>	<u>PART NAME</u>	<u>QTY.</u>	<u>REMARKS</u>
1	12210ZH7000	CYLINDER HEAD	1	INCLUDES ITEMS W/*
2*	12204ZE1306	GUIDE, VALVE (OS) OPTIONAL	1	
3*	12205ZE1315	GUIDE, EX. VALVE (OS) OPTIONAL	1	INCLUDES ITEMS W/+
4*+	12216ZE5300	CLIP, VALVE GUIDE	1	
5	12251ZH7800	GASKET, CYLINDER HEAD	1	
6	12310ZE1000	COVER, HEAD	1	
6	12310ZE1010	COVER, HEAD	1	
7	12391ZE1000	GASKET, CYLINDER HEAD COVER	1	
8	15721ZH8000	TUBE, BREATHER	1	
9	90013883000	BOLT, FLANGE 6X12 (CT200)	4	
10	90043ZE1020	BOLT, STUD 6X109	2	
11	90047ZE1000	BOLT, STUD 8X32	2	
12	9430110160	PIN, A, DOWEL 10X16	2	
14	957230805500	BOLT, FLANGE 8X55	4	
15	9807955846	SPARK PLUG BPR6ES (NGK)	1	

HONDA GX120K1QX2 ENGINE — FAN COVER ASSY.

FAN COVER ASSY.

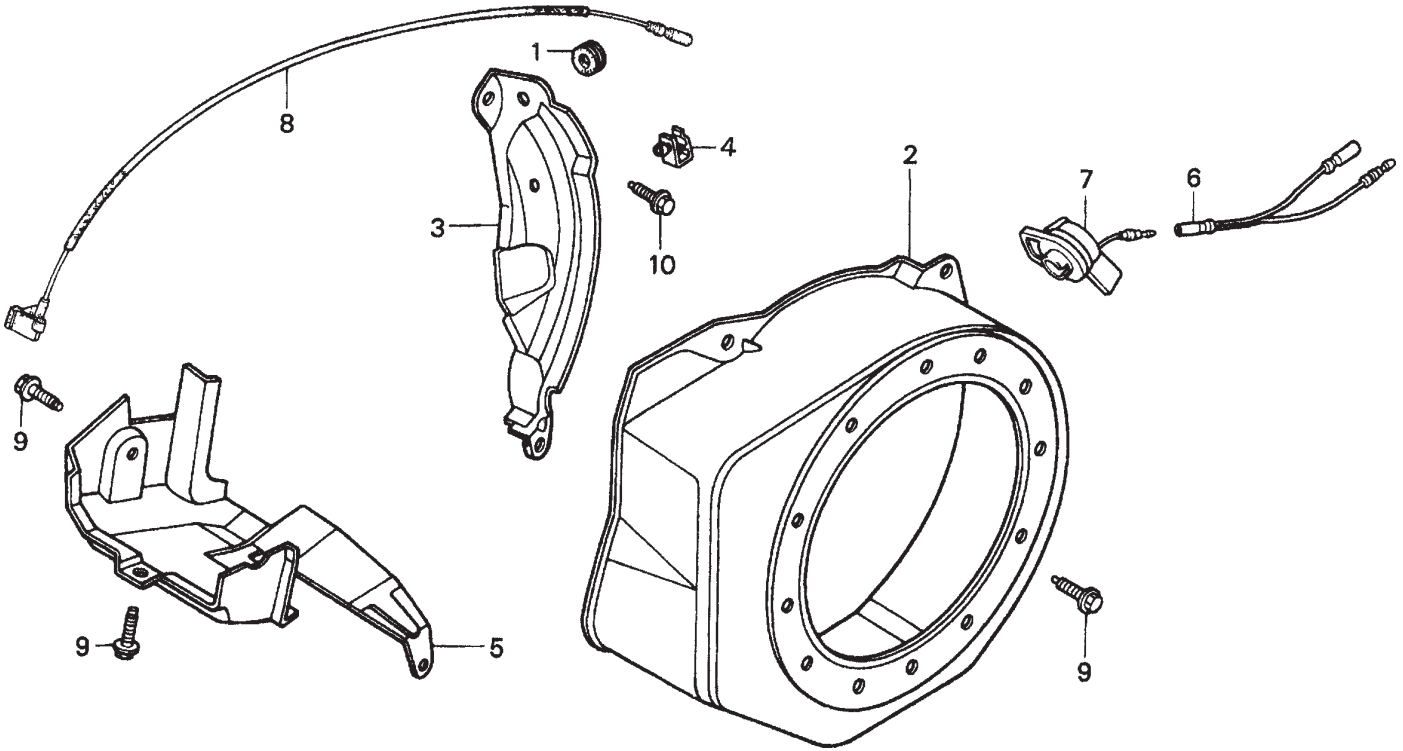

HONDA GX120K1QX2 ENGINE — FAN COVER ASSY.

FAN COVER ASSY.

<u>NO.</u>	<u>PART NO.</u>	<u>PART NAME</u>	<u>QTY.</u>	<u>REMARKS</u>
1	11347371300	GROMMET, ADJUSTING COVER	1	
2	19610ZE0000ZE	COVER, FAN *NH1* BLACK	1	
3	19611ZH7810	PLATE, SIDE (OIL ALERT)	1	
4	90601ZH7013	CLIP, HARNESS	1	
5	19630ZH7000	SHROUD	1	
6	32197ZH8003	SUB- HARNESS	1	
7	36100ZE1015	SWITCH ASSEMBLY, ENGINE STOP	1	
7	36100ZH7003	SWITCH ASSEMBLY, ENGINE STOP	1	
8	36101ZE1010	WIRE, STOP SWITCH 370MM	1	
9	90013883000	BOLT, FLANGE 6X12 (CT200)	6	
10	90022888010	BOLT, FLANGE 6X12 (CT200)	1	
11	34150ZH7003	ALERT UNIT, OIL	1	
13	957010600800	BOLT, FLANGE 6X8	1	

HONDA GX120K1QX2 ENGINE — FLYWHEEL ASSY.

FLYWHEEL ASSY.

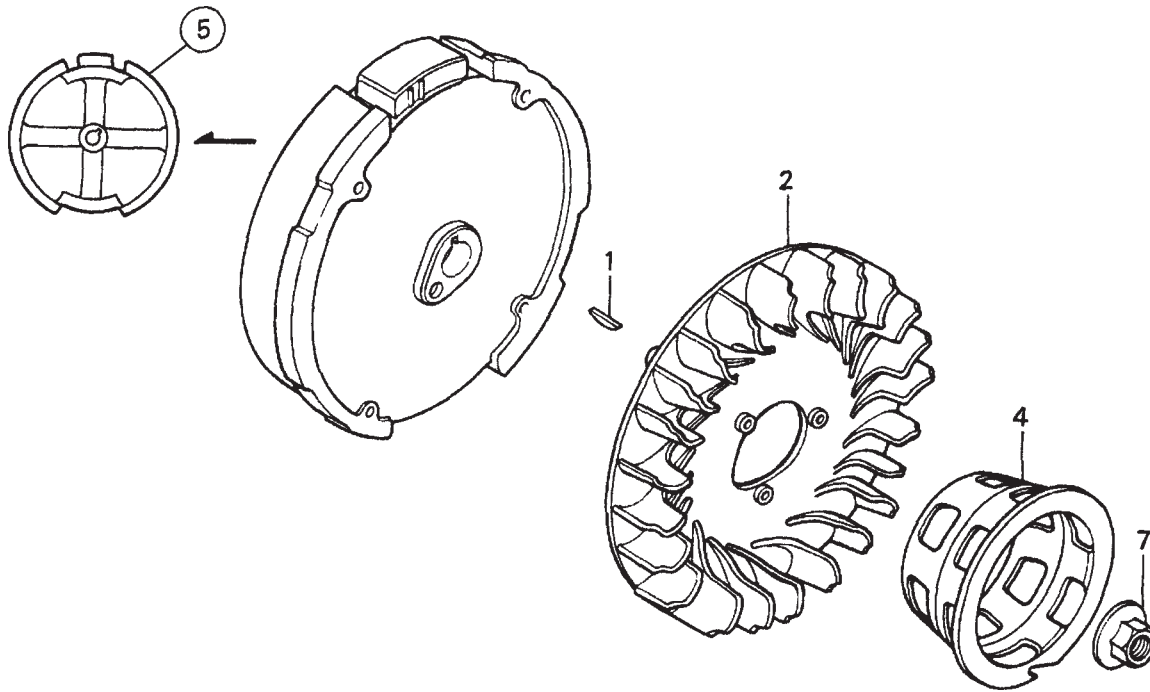

HONDA GX120K1QX2 ENGINE — FLYWHEEL ASSY.

FLYWHEEL ASSY.

<u>NO.</u>	<u>PART NO.</u>	<u>PART NAME</u>	<u>QTY.</u>	<u>REMARKS</u>
1	13331357000	KEY, SPECIAL WOODRUFF 25X18	1	
2	19511ZE0000	FAN, COOLING	1	
4	28451ZH8003	PULLEY, STARTER	1	
5	31100ZE0010	FLYWHEEL	1	
7	90201878003	NUT, SPECIAL 14MM	1	

HONDA GX120K1QX2 ENGINE — FUEL TANK ASSY.

FUEL TANK ASSY.

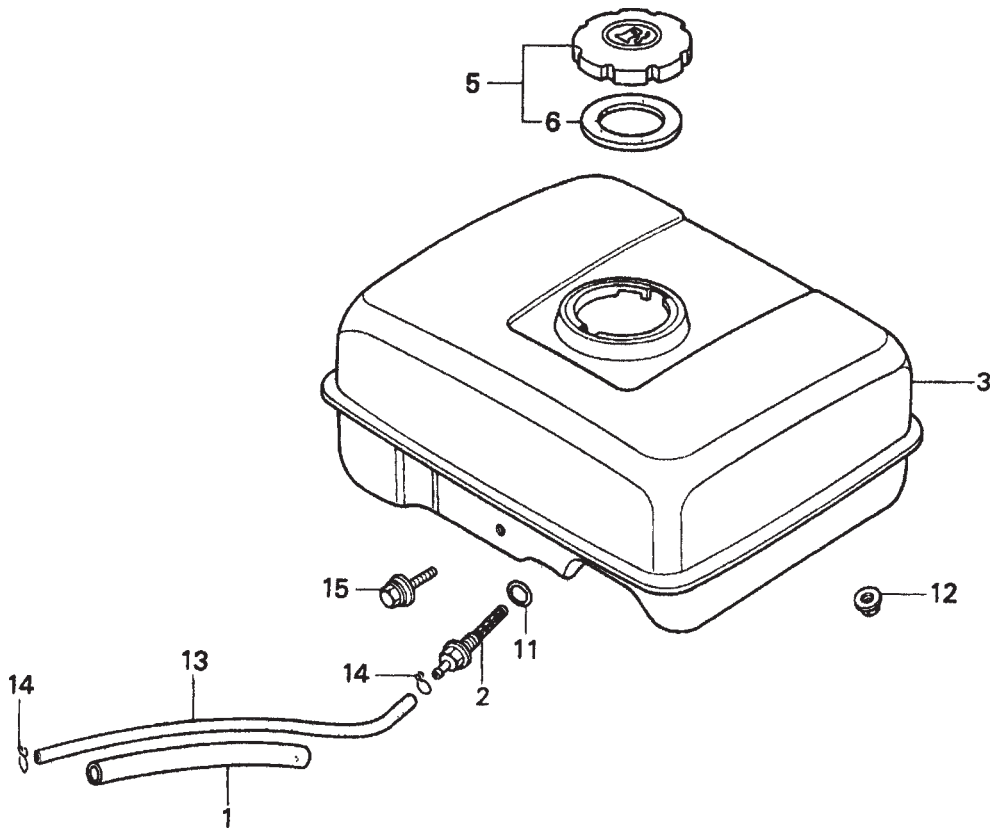

HONDA GX120K1QX2 ENGINE — FUEL TANK ASSY.

FUEL TANK ASSY.

<u>NO.</u>	<u>PART NO.</u>	<u>PART NAME</u>	<u>QTY.</u>	<u>REMARKS</u>
1	16854ZH8000	RUBBER, SUPPORTER 107MM	1	
2	16955ZE1000	JOINT, FUEL TANK	1	
3	17510ZE0020ZD	TANK, FUEL *NH1* (BLACK)	1	
5	17620ZH7023	CAP, FUEL FILLER	1 INCLUDES ITEMS W/*
6*	17631ZH7003	GASKET, FUEL FILLER CAP	1	
11	91353671003	O- RING 13.5X1.5 (ARAI)	1	
12	9405006000	NUT, FLANGE 6MM	2	
13	950014500360M	BULK HOSE, FUEL (4.5X3000) (4.5X140)	1	
14	9500202080	CLIP, TUBE (B8)	2	
15	90004ZH7003	BOLT, FLANGE 6X29	1	

HONDA GX120K1QX2 ENGINE — IGNITION COIL ASSY.

IGNITION COIL ASSY.

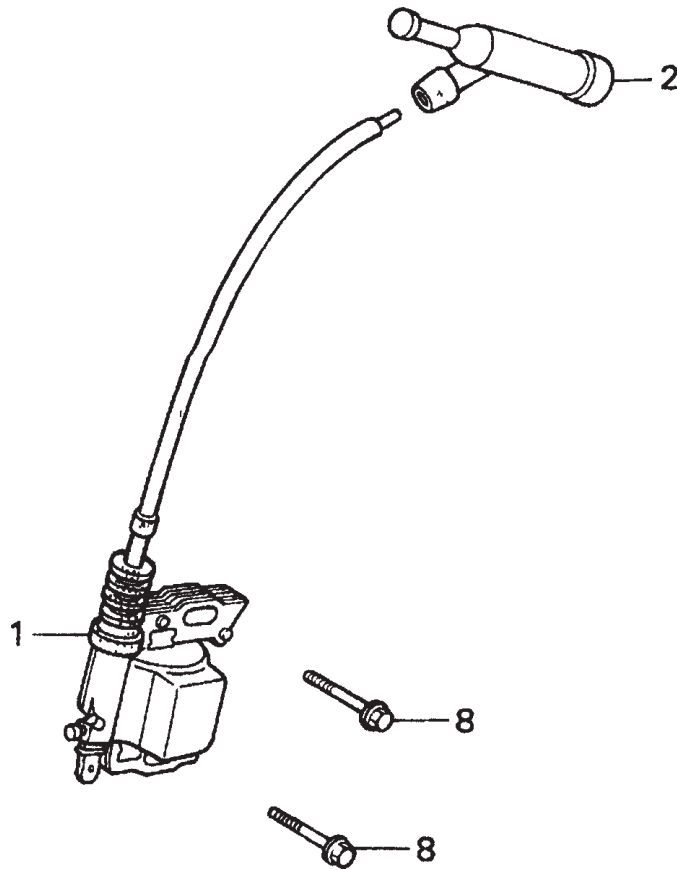

HONDA GX120K1QX2 ENGINE — IGNITION COIL ASSY.

IGNITION COIL ASSY.

<u>NO.</u>	<u>PART NO.</u>	<u>PART NAME</u>	<u>QTY.</u>	<u>REMARKS</u>
1	30500ZE1033	COIL ASSEMBLY, IGNITION	1	
2	30700ZE1013	CAP ASSEMBLY, NOISE SUPPRESSOR	1	
8	90121952000	BOLT, FLANGE 6X25	2	

HONDA GX120K1QX2 ENGINE — MUFFLER ASSY.

MUFFLER ASSY.

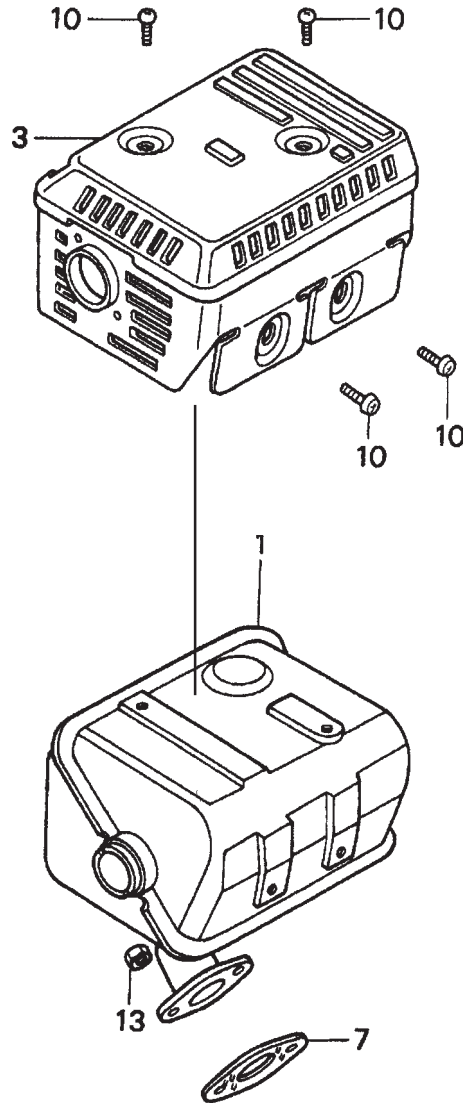

HONDA GX120K1QX2 ENGINE — MUFFLER ASSY.

MUFFLER ASSY.

<u>NO.</u>	<u>PART NO.</u>	<u>PART NAME</u>	<u>QTY.</u>	<u>REMARKS</u>
1	18310ZF1000	MUFFLER	1	
3	18320ZF1H01	PROTECTOR, MUFFLER	1	
7	18381ZH8800	GASKET, MUFFLER	1	
10	90050ZE1000	SCREW, TAPPING 5X8	4	
13	94001080000S	NUT, HEX. 8MM	2	

HONDA GX120K1QX2 ENGINE — PISTON ASSY.

PISTON ASSY.

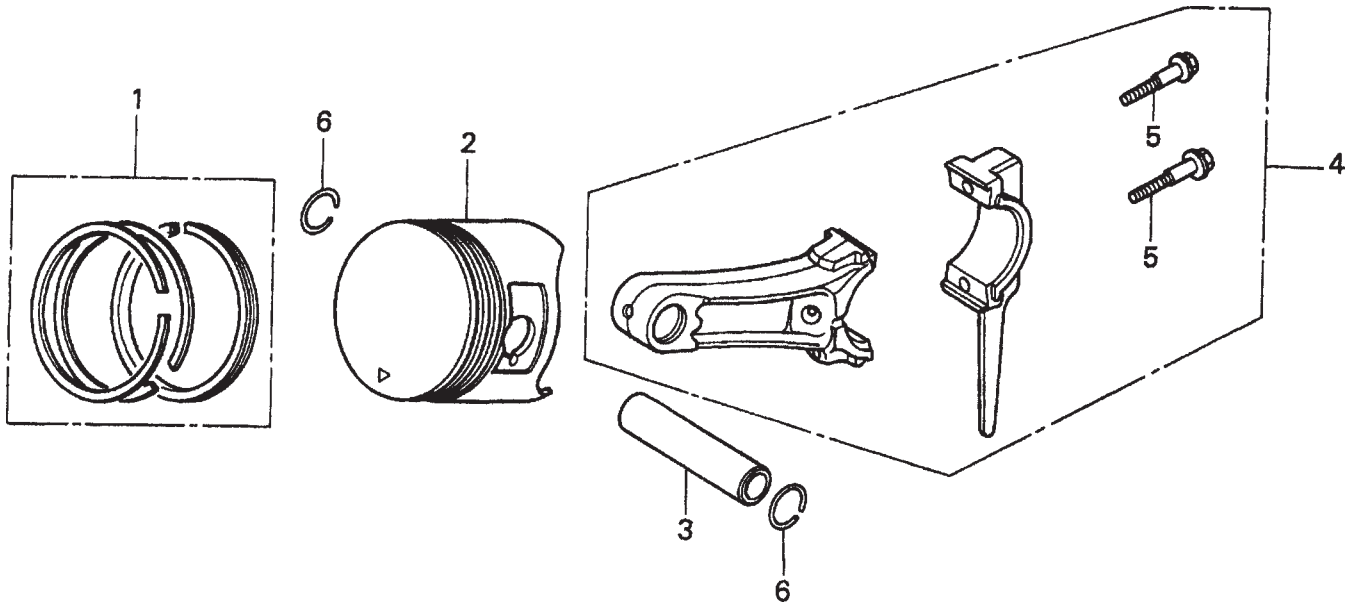

HONDA GX120K1QX2 ENGINE — PISTON ASSY.

PISTON ASSY.

<u>NO.</u>	<u>PART NO.</u>	<u>PART NAME</u>	<u>QTY.</u>	<u>REMARKS</u>
1	13010ZK7V01	RING SET, PISTON (STANDARD)	1	
1	13011ZE6013	RING SET, PISTON (OS 0.25), OPTIONAL	1	
1	13012ZK7V01	RING SET, PISTON (OS 0.50) , OPTIONAL	1	
1	13013ZK7V01	RING SET, PISTON (OS 0.75), OPTIONAL	1	
2	13101ZH7000	PISTON, STANDARD	1	
2	13102ZH7000	PISTON, OS 0.25	1	
2	13103ZH7000	PISTON, OS 0.50	1	
2	13104ZH7000	PISTON, 0.75	1	
3	13111ZE0000	PIN, PISTON	1	
4	132A0ZE0000	ROD ASSY, CONNECTING (UNDER SIZE)	1	INCLUDES ITEMS W/*
4	13200ZE0000	ROD ASSEMBLY, CONNECTING	1	INCLUDES ITEMS W/*
5*	90001ZE1000	BOLT, CONNECTING ROD	2	
6	90551ZE0000	CLIP, PISTON PIN 13MM	2	

HONDA GX120K1QX2 ENGINE — RECOIL STARTER ASSY.

RECOIL STARTER ASSY.

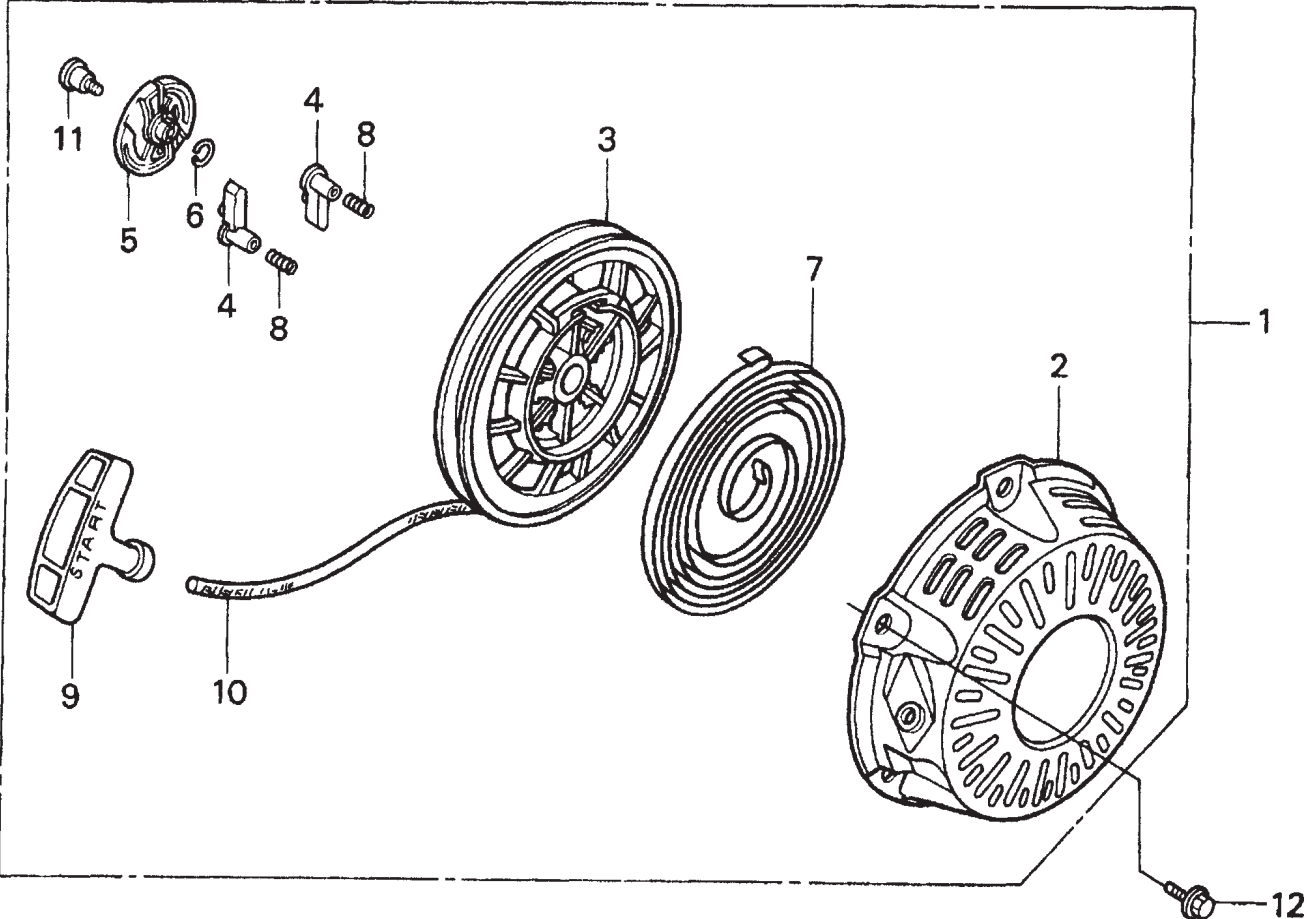

HONDA GX120K1QX2 ENGINE — RECOIL STARTER ASSY.

RECOIL STARTER ASSY.

<u>NO.</u>	<u>PART NO.</u>	<u>PART NAME</u>	<u>QTY.</u>	<u>REMARKS</u>
1	28400ZH8013ZB	STARTER ASSY., RECOIL *NH1* (BLACK)	1	INCLUDES ITEMS W/*
2*	28410ZH8003ZB	CASE, RECOIL STARTER *NH1* (BLACK)	1	
3*	28420ZH8013	REEL, RECOIL STARTER	1	
4*	28422ZH8013	RATCHET, STARTER	2	
5*	28433ZH8003	GUIDE, RATCHET	1	
6*	28441ZH8003	SPRING, FRICTION	1	
7*	28442ZH8003	SPRING, RECOIL STARTER	1	
8*	28443ZH8003	SPRING, RETURN	2	
9*	28461ZH8003	KNOB, RECOIL STARTER	1	
10*	28462ZH8003	ROPE, RECOIL STARTER	1	
11*	90003ZH8003	SCREW, SETTING	1	
12	9008ZE2003	BOLT, FLANGE 6X10	3	

HONDA GX120K1QX2 ENGINE — GASKET KIT ASSY.

GASKET KIT ASSY.

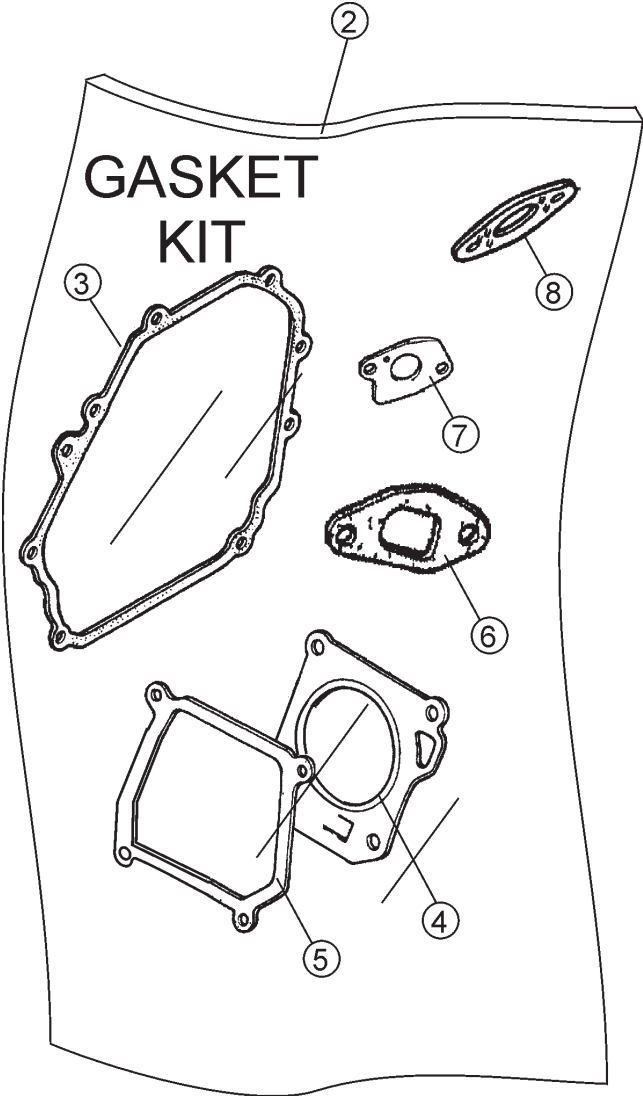

HONDA GX120K1QX2 ENGINE — GASKET KIT ASSY.

GASKET KIT ASSY.

<u>NO.</u>	<u>PART NO.</u>	<u>PART NAME</u>	<u>QTY.</u>	<u>REMARKS</u>
2	06111ZH7405	GASKET KIT	1	INCLUDES ITEMS W/*
3*	11381ZH7800	GASKET, CASE COVER	1	
4*	12251ZH7800	GASKET, CYLINDER HEAD	1	
5*	12391ZE1000	GASKET, CYLINDER HEAD COVER	1	
6*	16212ZH7800	GASKET, INSULATOR	1	
7*	16221ZH8801	GASKET, CARBURETOR	1	
8*	18381ZH8800	GASKET, MUFFLER	1	

HONDA GX120K1QX2 ENGINE — LABELS ASSY.

LABELS ASSY.

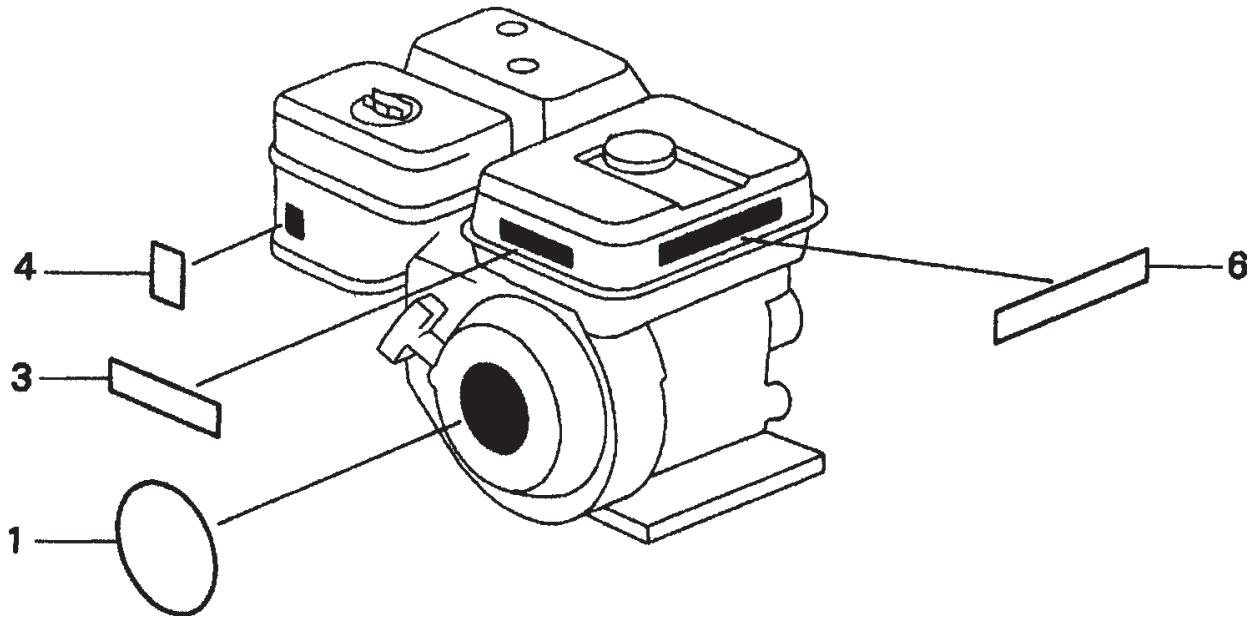

HONDA GX120K1QX2 ENGINE — LABELS ASSY.

LABELS ASSY.

<u>NO.</u>	<u>PART NO.</u>	<u>PART NAME</u>	<u>QTY.</u>	<u>REMARKS</u>
1	87521ZH7020	EMBLEM	1	
3	87522ZH9000	LABEL, CAUTION	1	
4	87528ZE1810	MARK, CHOKE	1	
6	87532ZH8810	MARK, OIL ALERT (E)	1	

TERMS AND CONDITION OF SALE — PARTS

PAYMENT TERMS

Terms of payment for parts are net 30 days.

FREIGHT POLICY

All parts orders will be shipped collect or prepaid with the charges added to the invoice. All shipments are F.O.B. point of origin. Multiquip's responsibility ceases when a signed manifest has been obtained from the carrier, and any claim for shortage or damage must be settled between the consignee and the carrier.

MINIMUM ORDER

The minimum charge for orders from Multiquip is \$15.00 net. Customers will be asked for instructions regarding handling of orders not meeting this requirement.

RETURNED GOODS POLICY

Return shipments will be accepted and credit will be allowed, subject to the following provisions:

1. A Returned Material Authorization must be approved by Multiquip prior to shipment.
2. To obtain a Return Material Authorization, a list must be provided to Multiquip Parts Sales that defines item numbers, quantities, and descriptions of the items to be returned.
 - a. The parts numbers and descriptions must match the current parts price list.
 - b. The list must be typed or computer generated.
 - c. The list must state the reason(s) for the return.
 - d. The list must reference the sales order(s) or invoice(s) under which the items were originally purchased.
 - e. The list must include the name and phone number of the person requesting the RMA.
3. A copy of the Return Material Authorization must accompany the return shipment.
4. Freight is at the sender's expense. All parts must be returned freight prepaid to Multiquip's designated receiving point.

5. Parts must be in new and resalable condition, in the original Multiquip package (if any), and with Multiquip part numbers clearly marked.
6. The following items are not returnable:
 - a. Obsolete parts. (If an item is in the price book and shows as being replaced by another item, it is obsolete.)
 - b. Any parts with a limited shelf life (such as gaskets, seals, "O" rings, and other rubber parts) that were purchased more than six months prior to the return date.
 - c. Any line item with an extended dealer net price of less than \$5.00.
 - d. Special order items.
 - e. Electrical components.
 - f. Paint, chemicals, and lubricants.
 - g. Decals and paper products.
 - h. Items purchased in kits.
7. The sender will be notified of any material received that is not acceptable.
8. Such material will be held for five working days from notification, pending instructions. If a reply is not received within five days, the material will be returned to the sender at his expense.
9. Credit on returned parts will be issued at dealer net price at time of the original purchase, less a 15% restocking charge.
10. In cases where an item is accepted, for which the original purchase document can not be determined, the price will be based on the list price that was effective twelve months prior to the RMA date.
11. Credit issued will be applied to future purchases only.

PRICING AND REBATES

Prices are subject to change without prior notice. Price changes are effective on a specific date and all orders received on or after that date will be billed at the revised price. Rebates for price declines and added charges for price increases will not be made for stock on hand at the time of any price change.

Multiquip reserves the right to quote and sell direct to Government agencies, and to Original Equipment Manufacturer accounts who use our products as integral parts of their own products.

SPECIAL EXPEDITING SERVICE

A \$35.00 surcharge will be added to the invoice for special handling including bus shipments, insured parcel post or in cases where Multiquip must personally deliver the parts to the carrier.

LIMITATIONS OF SELLER'S LIABILITY

Multiquip shall not be liable hereunder for damages in excess of the purchase price of the item with respect to which damages are claimed, and in no event shall Multiquip be liable for loss of profit or good will or for any other special, consequential or incidental damages.

LIMITATION OF WARRANTIES

No warranties, express or implied, are made in connection with the sale of parts or trade accessories nor as to any engine not manufactured by Multiquip. Such warranties made in connection with the sale of new, complete units are made exclusively by a statement of warranty packaged with such units, and Multiquip neither assumes nor authorizes any person to assume for it any other obligation or liability whatever in connection with the sale of its products. Apart from such written statement of warranty, there are no warranties, express, implied or statutory, which extend beyond the description of the products on the face hereof.

Effective: February 22, 2006

OPERATION AND PARTS MANUAL

HERE'S HOW TO GET HELP

PLEASE HAVE THE MODEL AND SERIAL
NUMBER ON-HAND WHEN CALLING

UNITED STATES

Multiquip Corporate Office

18910 Wilmington Ave. Tel. (800) 421-1244
Carson, CA 90746 Fax (800) 537-3927
Contact: mq@multiquip.com

Mayco Parts

800-306-2926 Fax: 800-672-7877
310-537-3700 Fax: 310-637-3284

Service Department

800-421-1244 Fax: 310-537-4259
310-537-3700

MQ Parts Department

800-427-1244 Fax: 800-672-7877
310-537-3700 Fax: 310-637-3284

Warranty Department

800-421-1244, Ext. 279 Fax: 310-537-1173
310-537-3700, Ext. 279

Technical Assistance

800-478-1244 Fax: 310-631-5032

MEXICO

MQ Cipsa

Carr. Fed. Mexico-Puebla KM 126.5 Tel: (52) 222-225-9900
Momoxpan, Cholula, Puebla 72760 Mexico Fax: (52) 222-285-0420
Contact: pmastretta@cipsa.com.mx

CANADA

Multiquip

4110 Industriel Boul. Tel: (450) 625-2244
Laval, Quebec, Canada H7L 6V3 Tel: (877) 963-4411
Contact: jmartin@multiquip.com Fax: (450) 625-8664

UNITED KINGDOM

Multiquip (UK) Limited Head Office

Unit 2, Northpoint Industrial Estate, Tel: 0161 339 2223
Global Lane, Fax: 0161 339 3226
Dukinfield, Cheshire SK16 4UJ
Contact: sales@multiquip.co.uk

© COPYRIGHT 2010, MULTIQUIP INC.

Multiquip Inc and the MQ logo are registered trademarks of Multiquip Inc. and may not be used, reproduced, or altered without written permission. All other trademarks are the property of their respective owners and used with permission.

This manual MUST accompany the equipment at all times. This manual is considered a permanent part of the equipment and should remain with the unit if resold.

The information and specifications included in this publication were in effect at the time of approval for printing. Illustrations, descriptions, references and technical data contained in this manual are for guidance only and may not be considered as binding. Multiquip Inc. reserves the right to discontinue or change specifications, design or the information published in this publication at any time without notice and without incurring any obligations.

Your Local Dealer is:

