

# OPERATION AND PARTS MANUAL



## MODEL QP-402H CENTRIFUGAL PUMP

(Honda GX240K1PMT2/GX240U1PMT2  
Gasoline Engine)

Revision #1 (04/02/08)

To find the latest revision of this  
publication, visit our website at:  
[www.multiquip.com](http://www.multiquip.com)



THIS MANUAL MUST ACCOMPANY THE EQUIPMENT AT ALL TIMES.



**CALIFORNIA — Proposition 65 Warning**

Engine exhaust and some of its constituents are known to the State of California to cause cancer, birth defects and other reproductive harm.



**QP-402H Gasoline  
Powered Centrifugal  
Pump**

Proposition 65 Warning ..... 2  
 Table of Contents ..... 4  
 Parts Ordering Procedures ..... 5  
 Safety Message Alert Symbols ..... 6-7  
 Rules For Safe Operation ..... 8-9  
 Pump Specifications/Dimensions ..... 10  
 Engine Specifications ..... 11  
 General Information ..... 12  
 Pump Components ..... 13  
 Refueling ..... 14  
 Basic Engine ..... 15  
 Pre-Inspection (Engine) ..... 16  
 Pre-Set-up (Pump) ..... 17  
 Initial Start-up (Engine) ..... 18-19  
 Maintenance (Pump) ..... 20-21  
 Maintenance (Engine) ..... 22-23  
 Preparation for Long-Term Storage ..... 24  
 Troubleshooting (Engine) ..... 25  
 Troubleshooting (Engine/Pump) ..... 26  
 Explanation Of Code In Remarks Column ..... 28  
 Suggested Spare Parts ..... 29

**Component Drawing**

Pump Assembly. .... 30-31

**Honda GX240K1PMT2/  
GX240U1PMT2 Engines**

Air Cleaner Assembly ..... 32-33  
 Camshaft Assembly ..... 34-35  
 Carburetor Assembly ..... 36-39  
 Control Assembly ..... 40-41  
 Crankcase Cover Assembly ..... 42-43  
 Crankshaft Assembly ..... 44-45  
 Cylinder Barrel Assembly ..... 46-47  
 Cylinder Head Assembly ..... 48-49  
 Fan Cover Assembly ..... 50-51  
 Flywheel Assembly ..... 52-53  
 Fuel Tank Assembly ..... 54-55  
 Ignition Coil Assembly ..... 56-57  
 Muffler Assembly ..... 58-59  
 Piston Assembly ..... 60-61  
 Recoil Starter Assembly ..... 62-63  
 Gasket Kit Assembly ..... 64-65  
 Labels Assembly ..... 66-67

Terms and Condition Of Sale — Parts ..... 68

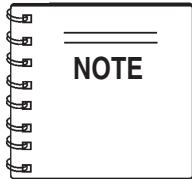

*Specification and part number  
are subject to change without  
notice.*

# PARTS ORDERING PROCEDURES

## Ordering parts has never been easier! Choose from three easy options:

Effective:  
January 1<sup>st</sup>, 2006

www.multiquip.com



### Order via Internet (Dealers Only):

Order parts on-line using Multiquip's SmartEquip website!

- View Parts Diagrams
- Order Parts
- Print Specification Information



If you have an MQ Account, to obtain a Username and Password, E-mail us at: [parts@multiquip.com](mailto:parts@multiquip.com).

To obtain an MQ Account, contact your District Sales Manager for more information.

Goto [www.multiquip.com](http://www.multiquip.com) and click on **Order Parts** to log in and save!

Use the **internet** and qualify for a **5% Discount** on **Standard orders** for all orders which include complete part numbers.\*

Note: Discounts Are Subject To Change



### Order via Fax (Dealers Only):

All customers are welcome to order parts via Fax.

**Domestic (US) Customers dial:**  
1-800-6-PARTS-7 (800-672-7877)

**Fax** your order in and qualify for a **2% Discount** on **Standard orders** for all orders which include complete part numbers.\*

Note: Discounts Are Subject To Change



**Order via Phone: Domestic (US) Dealers Call:**  
1-800-427-1244

### Non-Dealer Customers:

Contact your local Multiquip Dealer for parts or call 800-427-1244 for help in locating a dealer near you.



**International Customers** should contact their local Multiquip Representatives for Parts Ordering information.

## When ordering parts, please supply:

- |                                                                               |                                                                                        |
|-------------------------------------------------------------------------------|----------------------------------------------------------------------------------------|
| <input type="checkbox"/> Dealer Account Number                                | <input type="checkbox"/> Specify Preferred Method of Shipment:                         |
| <input type="checkbox"/> Dealer Name and Address                              | <input checked="" type="checkbox"/> UPS/Fed Ex <input checked="" type="checkbox"/> DHL |
| <input type="checkbox"/> Shipping Address (if different than billing address) | <input type="checkbox"/> Priority One <input checked="" type="checkbox"/> Truck        |
| <input type="checkbox"/> Return Fax Number                                    | <input type="checkbox"/> Ground                                                        |
| <input type="checkbox"/> Applicable Model Number                              | <input type="checkbox"/> Next Day                                                      |
| <input type="checkbox"/> Quantity, Part Number and Description of Each Part   | <input type="checkbox"/> Second/Third Day                                              |

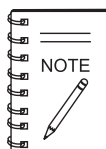

All orders are treated as *Standard Orders* and will ship the same day if received prior to 3PM PST.

WE ACCEPT ALL MAJOR CREDIT CARDS!



# QP-402H — SAFETY MESSAGE ALERT SYMBOLS

## FOR YOUR SAFETY AND THE SAFETY OF OTHERS!

Safety precautions should be followed at all times when operating this equipment. Failure to read and understand the Safety Messages and Operating Instructions could result in injury to yourself and others.

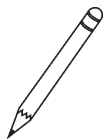
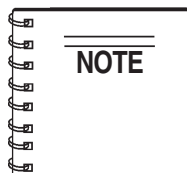

This Owner's Manual has been developed to provide complete instructions for the safe and efficient operation of the Multiquip **QP-402H Centrifugal Pump**.

Refer to the engine manufacturer's instructions for data relative to its safe operation.

**Before using this centrifugal pump, ensure that the operating individual has read and understands all instructions in this manual.**

## SAFETY MESSAGE ALERT SYMBOLS

The three (3) Safety Messages shown below will inform you about potential hazards that could injure you or others. The Safety Messages specifically address the level of exposure to the operator, and are preceded by one of three words: **DANGER**, **WARNING**, or **CAUTION**.

### **DANGER**

You **WILL** be **KILLED** or **SERIOUSLY INJURED** if you **DO NOT** follow these directions.

### **WARNING**

You **CAN** be **KILLED** or **SERIOUSLY INJURED** if you **DO NOT** follow these directions.

### **CAUTION**

You **CAN** be **INJURED** if you **DO NOT** follow these directions.

Potential hazards associated with the operation of this equipment will be referenced with Hazard Symbols which appear throughout this manual, and will be referenced in conjunction with Safety Message Alert Symbols.

## HAZARD SYMBOLS

### **WARNING - Lethal Exhaust Gases**

Engine exhaust gases contain poisonous carbon monoxide. This gas is colorless and odorless, and can cause death if inhaled. **NEVER** operate this equipment in a confined area or enclosed structure that does not provide ample free flow air.



### **WARNING - Explosive Fuel**

**Gasoline** is extremely flammable, and its vapors can cause an explosion if ignited. **DO NOT** start the engine near spilled fuel or combustible fluids.



**DO NOT** fill the fuel tank while the engine is running or hot. **DO NOT** overfill tank, since spilled fuel could ignite if it comes into contact with hot engine parts or sparks from the ignition system. Store fuel in approved containers, in well-ventilated areas and away from sparks and flames.

### **WARNING - Burn Hazards**

Engine components can generate extreme heat. To prevent burns, **DO NOT** touch these areas while the engine is running or immediately after operations. Never operate the engine with heat shields or heat guards removed.



### **CAUTION - Respiratory Hazard**

**ALWAYS** wear approved **respiratory** protection when required.



# QP-402H — SAFETY MESSAGE ALERT SYMBOLS

## CAUTION - Rotating Parts

**NEVER** operate equipment with covers, or guards removed. Keep fingers, hands, hair and clothing away from all moving parts to prevent injury.



## CAUTION - Accidental Starting

**ALWAYS** place the engine **ON/OFF** switch in the **OFF** position, when the pump is not in use.



## CAUTION - Sight and Hearing Hazards

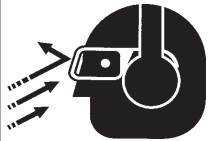

**ALWAYS** wear approved eye and hearing protection.

## WARNING - Do Not Run the Pump Dry

If the pump loses prime while operating, the remaining water in the casing will reach near-boiling temperatures within approximately 15 minutes. **NEVER** operate the pump without water flowing through the pump. Allow pump casing to cool to the touch before opening the fill or drain caps or before removing any hoses to avoid serious burns and bodily injury to the operator.

## CAUTION - Equipment Damage Messages

Other important messages are provided throughout this manual to help prevent damage to your pump, other property, or the surrounding environment.

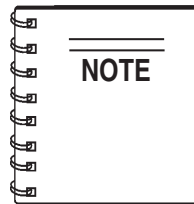

This pump, other property, or the surrounding environment could be damaged if you do not follow instructions.

# QP-402H — RULES FOR SAFE OPERATION

## DANGER - READ THIS MANUAL!

Failure to follow instructions in this manual may lead to **serious injury** or even **DEATH!** This equipment is to be operated by trained and qualified personnel only! This equipment is for industrial use only.

The following safety guidelines should always be used when operating the **QP402H Centrifugal Pump**.

### General Safety:

- **DO NOT** operate or service this equipment before reading this entire manual.



The operator **MUST BE** familiar with proper safety precautions and operations techniques before using generator.

- This equipment should not be operated by persons under 18 years of age.
- **NEVER** operate this equipment without proper protective clothing, shatterproof glasses, steel-toed boots and other protective devices required by the job.



- **NEVER** operate this equipment when not feeling well due to fatigue, illness or taking medicine.
- **NEVER** operate this equipment under the influence of drugs or alcohol.



- **ALWAYS** wear proper respiratory (mask), hearing and eye protection equipment when operating the generator.



- Whenever necessary, replace nameplate, operation and safety decals when they become difficult read.
- Manufacturer does not assume responsibility for any accident due to equipment modifications. Unauthorized equipment modification will void all warranties.

- **NEVER** use accessories or attachments, which are not recommended by Multiquip for this equipment. Damage to the equipment and/or injury to user may result.

- **NEVER** touch the hot exhaust manifold, muffler or cylinder. Allow these parts to cool before servicing engine or pump.

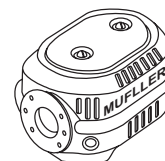

- The engine section of this pump requires an adequate free flow of cooling air. **NEVER** operate the pump in any enclosed or narrow area where free flow of the air is restricted. If the air flow is restricted it will cause serious damage to the pump or engine and may cause injury to people. Remember the pump's engine gives off **DEADLY** carbon monoxide gas.

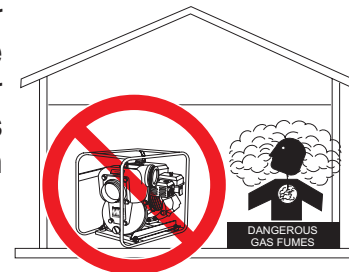

- **ALWAYS** refuel in a well-ventilated area, away from sparks and open flames.

- **ALWAYS** use extreme caution when working with **flammable** liquids. When refueling, **stop the engine** and allow it to cool. **DO NOT smoke** around or near the machine. Fire or explosion could result from fuel vapors, or if fuel is spilled on a hot engine.



- **NEVER** operate the pump in an explosive atmosphere or near combustible materials. An explosion or fire could result causing severe **bodily harm or even death**.

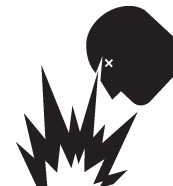

- **NEVER** disconnect any **"emergency or safety devices"**. These devices are intended for operator safety. Disconnection of these devices can cause severe injury, bodily harm or even death! Disconnection of any of these devices will void all warranties.

# QP-402H — RULES FOR SAFE OPERATION

- **NEVER** run engine without air cleaner. Severe engine damage may occur.
- **ALWAYS** read, understand, and follow procedures in Operator's Manual before attempting to operate equipment.
- **ALWAYS** be sure the operator is familiar with proper safety precautions and operation techniques before using pump.
- **ALWAYS** store equipment properly when it is not being used. Equipment should be stored in a clean, dry location out of the reach of children.
- **NEVER** leave the pump unattended, turn off engine when unattended.
- Unauthorized equipment modifications will void all warranties.
- **NEVER** pump volatile, explosive, flammable or low flash point fluids. These fluids could ignite or explode.
- **NEVER** operate the pump in an **explosive** atmosphere.
- Before starting the pump, check that the clean-out cover is securely fasten.
- **ALWAYS** ensure pump is on level ground before use.
- Become familiar with the components of the pump before operating.
- **ALWAYS** replace any worn or damaged warning decals.
- **NEVER** pump corrosive chemicals or water containing toxic substances. These fluids could create serious health and environmental hazards. Contact local authorities for assistance.
- **NEVER** open the priming plug when pump is hot. Hot water inside could be pressurized much like the radiator of an automobile. Allow pump to cool to the touch before loosening plug. The possibility exists of scalding, resulting in severe bodily harm.
- **NEVER** open the pump housing during operation or start the pump with the clean-out cover removed. The rotating impeller inside the pump can cut or sever objects caught in it.
- **NEVER** block or restrict flow from discharge hose. Remove kinks from discharge line before starting pump. Operation with a blocked discharge line can cause water inside pump to overheat.
- **ALWAYS** fill the pump casing with water before starting the engine. Failure to maintain water inside the pump housing will cause severe damage to the pump.
- In winter drain water from pump housing to prevent freezing.



## Maintenance Safety:

- **NEVER** lubricate components or attempt service on a running machine.
- **ALWAYS** allow the machine a proper amount of time to cool before servicing.
- Keep the machinery in proper running condition.
- Fix damage to the machine immediately and always replace broken parts.
- Dispose of hazardous waste properly. Examples of potentially hazardous waste are used motor oil, fuel and fuel filters.
- **DO NOT** use food or plastic containers to dispose of hazardous waste.
- **DO NOT** pour waste, oil or fuel directly onto the ground, down a drain or into any water source.

## TRANSPORTING

- **ALWAYS** shutdown engine before transporting.
- Tighten fuel tank cap securely and close fuel cock to prevent fuel from spilling.
- Drain fuel when transporting pump over long distances or bad roads.
- **ALWAYS** tie down the pump during transportation by securing the pump's guard frame with rope.

## EMERGENCIES

- **ALWAYS** know the location of the nearest **fire extinguisher**.
- **ALWAYS** know the location of the nearest **first aid kit**.
- In emergencies **always** know the location of the nearest phone or **keep a phone on the job site**. Also know the phone numbers of the nearest **ambulance, doctor** and **fire department**. This information will be invaluable in case of an emergency.



- **NEVER** disconnect any **"emergency or safety devices"**. These devices are intended for operator safety. Disconnection of these devices can cause severe injury, bodily harm or even death! Disconnection of any of these devices will void all warranties.

# QP-402H — SPECIFICATIONS/DIMENSIONS (PUMP)

## Table 1. Specifications (Pump)

<b>Pump</b>	<b>Model</b>	<b>QP-402H</b>
	Type	Centrifugal Pump
	Suction & Discharge Size	4.00 in. (101 mm.)
	Maximum Pumping Capacity	425 gallons/minute (1615 liters/minute)
	Max. Lift	25 ft. (7.62 meters)
	Max. Head	100 ft. (30.0 meters)
<b>Dimension (L x W x H)</b>		30.0 x 19.0 X 24.25 in. (76 X 48 X 61 cm.)
<b>Dry Net Weight</b>		145 lbs. (65 Kg.)

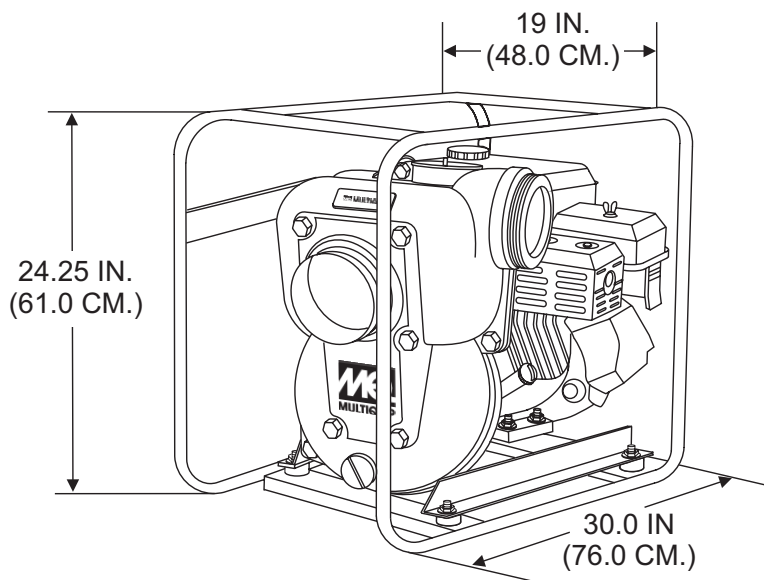

Figure 1. QP-402H Dimensions

**Table 2. Specifications (Engines)**

<b>Engine</b>	<b>Model</b>	<b>HONDA GX240K1PMT2/240U1PMT2</b>
	<b>Type</b>	Air-cooled 4 stroke, Single Cylinder, OHV, Horizontal Shaft Gasoline Engine
	<b>Bore X Stroke</b>	2.90 in. X 2.30 in. (73 mm x 58 mm)
	<b>Displacement</b>	14.81 cc
	<b>Max Output (K1)</b>	8.0 H.P./3600 R.P.M.
	<b>Max Output (U1)</b>	7.1H.P./3600 R.P.M.
	<b>Fuel Tank Capacity</b>	Approx. 1.59 U.S. Gallons (6 Liters)
	<b>Fuel</b>	Unleaded Automobile Gasoline
	<b>Lube Oil Capacity</b>	2-1/3 pints
	<b>Speed Control Method</b>	Centrifugal Fly-weight Type
	<b>Starting Method</b>	Recoil Start
<b>Dimension (L x W x H)</b>	14.0 x 16.9 X 16.1 in. (355 X 430 X 410 mm)	
<b>Dry Net Weight</b>	55.1 lbs (25 Kg.)	

# QP-402H — GENERAL INFORMATION

## APPLICATION

The **QP204H Centrifugal Pump** is designed to handle all types of clear water applications. It is ideal for residential use such as dewatering basements and swimming pools. Both the suction and discharge ports on the QP-402H pump use a 4-inch diameter opening, which allows the pump to pump at a rate of approximately 425 gallons/minute (gpm) or 1,615 liters/minute (lpm).

Centrifugal or self priming pumps are designed to purge air from the suction line and create a partial vacuum in the pump body. The reduced atmospheric pressure inside the pump allows water to flow through the suction line and into the pump body. The centrifugal force created by the rotating impeller pressurizes the water and expels it from the pump.

## Power Plant

This centrifugal pump is powered by either a Honda GX240K1 (8.0 H.P.) or a Honda GX240U1 (7.1 H.P.) air cooled 4-stroke, single cylinder gasoline engine that incorporates a low "**Oil Alert Feature.**"

## Oil Alert Feature

In the event of **low oil** or **no oil**, the HONDA GX-240 engine has a built-in oil alarm engine shut-down feature. In the event the oil level is low the engine will automatically shut-down.

## Standard Centrifugal Pump

Standard centrifugal pumps provide an economical choice for general purpose dewatering. These types of pumps should only be used in **clear water** applications (agricultural, industrial, residential) as they have a limited solid handling capability of only 10% by volume.

## Suction Lift

This pump is intended to be used for dewatering applications and is capable of suction lifts up to 25 feet at sea level. For optimal suction lift performance keep the suction hose or line as short as possible. In general, always place the pump as close to the water as possible.

## Pump Support

The pump should always be placed on **solid stationary ground**, on a level position.

**NEVER** place the pump on **soft soil**. The suction hose or pipe connection should always be checked for tightness and leaks. A small suction leak in the hose or fittings could prevent the pump from priming.

## Elevation

Higher elevations will effect the performance of the pump. Due to less atmospheric pressure at higher altitudes, pumps **DO NOT** have the priming ability that they have at sea level. This is due to the "thinner air" or lack of oxygen at higher altitudes.

A general rule of thumb is that for every 1,000 feet of elevation above sea level a pump will lose one foot of priming ability.

For example, in Flagstaff, Arizona where the elevation is approximately 7,000 feet, the pump would have a suction lift of only 18 feet rather than the 25 feet at sea level. Table 3 shows suction lift at various elevations.

Table 3. Suction Lift at Various Elevations

Altitude Feet (Meters)	Suction Lift in Feet (Meters)			
	Sea Level	10.0 (3.048)	15.0 (4.572)	20.0 (6.096)
2,000 (610)	8.80 (2.680)	13.2 (4.023)	17.6 (5.364)	22.0 (6.705)
4,000 (1,219)	7.80 (2.377)	11.7 (3.566)	15.6 (4.754)	19.5 (5.943)
6,000 (1,829)	6.90 (2.103)	10.4 (3.169)	13.8 (4.206)	17.3 (5.273)
8,000 (2,438)	6.20 (1.889)	9.30 (2.834)	12.4 (3.779)	15.5 (4.724)
10,000 (3,048)	5.70 (1.737)	8.60 (2.621)	11.4 (3.474)	14.3 (4.358)

Table 4 shows percentage drops in performance as elevation increases.

Table 4. Performance Loss at Various Elevations

Altitude Feet (Meters)	Discharge Flow	Discharge Head
Sea Level	100%	100%
2,000 (610)	97%	95%
4,000 (1,219)	95%	91%
6,000 (1,829)	93%	87%
8,000 (2,438)	91%	83%
10,000 (3,048)	88%	78%

## QP-402H — PUMP COMPONENTS

Figure 2 shows a typical application using the QP-402H centrifugal pump. Please note that this pump is intended for the removal of clean water.

Figure 2. QP-402H Pump Application

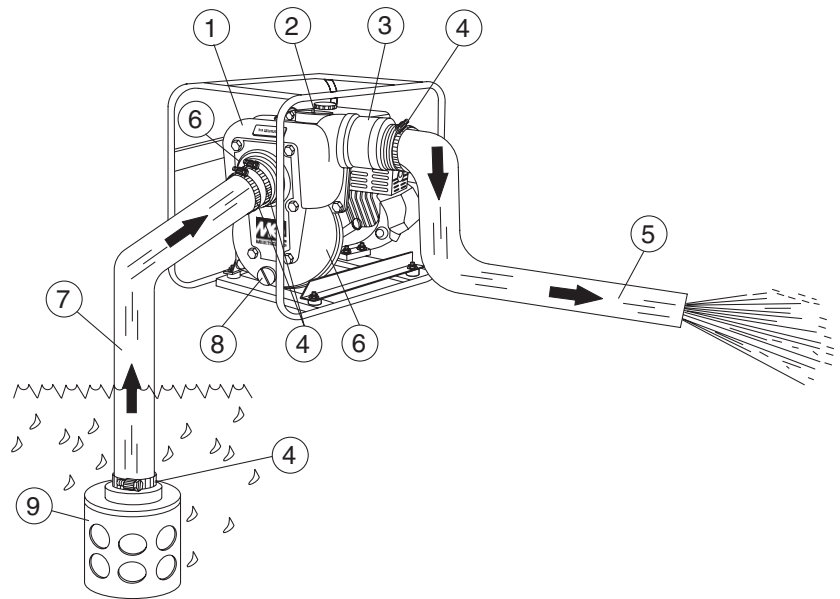

- 1. Pump** – The model QP-402H is a 4-inch centrifugal pump used in general de-watering applications. Typical dewatering applications consist of dewatering basements and swimming pools.
- 2. Fill Cap** – Prior to operation, the pump casing should be filled with water. Remove this cap to add water to the pump. After the initial prime, a sufficient amount of water will be retained in the casing so that the operator will not need to re-prime later.  
If the casing is dry or has insufficient water, the pump will have difficulty in priming which could lead to premature mechanical seal wear thus causing damage to the pump.
- 3. Discharge Port** – Connect a 4-inch discharge hose to this port.
- 4. Worm Clamp** – Used to secure the hose to the inlet and outlet ports on the pump. Use two clamps to secure the hose on the inlet side of the pump.
- 5. Discharge Hose** – Connect this flexible rubber hose to the discharge port on the pump. Make sure that the hose lays flat and is not kinked. Use only recommended type discharge hose. Contact Multiquip parts department for ordering information.
- 6. Suction Port** – Connect a 4-inch inlet hose to this port. Use two worm clamps to secure the hose.
- 7. Suction Hose** – Connect this flexible rubber hose to the suction port on the pump. Make sure that the hose lays flat and is not kinked. Use only recommended type suction hose. Contact Multiquip parts department for ordering information.
- 8. Drain Plug** – Remove this plug to drain water from the pump.
- 9. Strainer** – Always attach a strainer to bottom side of the suction hose to prevent large objects and debris from entering the pump. Strainer should be positioned so that it will remain completely under water. Running the pump with the strainer above water for long periods can damage pump.

**! DANGER - Fueling The Engine**

If pump is placed in a truck bed with a plastic liner, **REMOVE** pump from truck bed and place on ground (Figure 3) to refuel. The possibility of **fire** or **explosion** exists, due to static electricity.

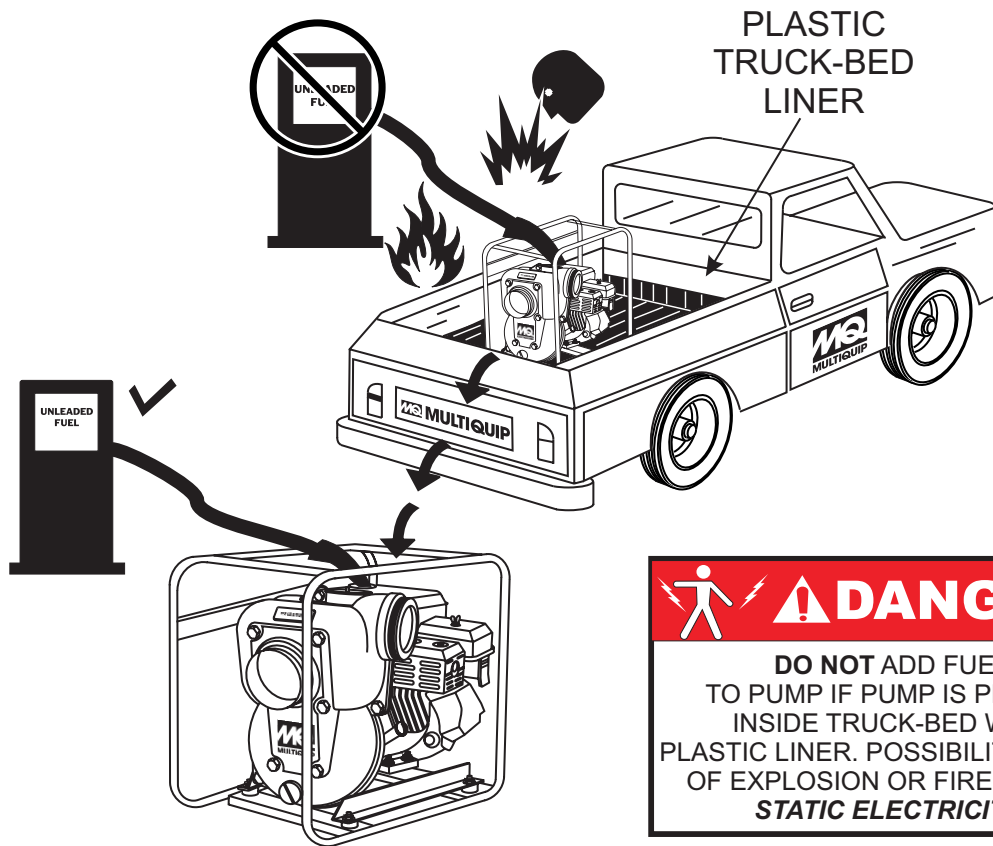

**! DANGER**  
**DO NOT ADD FUEL TO PUMP IF PUMP IS PLACED INSIDE TRUCK-BED WITH PLASTIC LINER. POSSIBILITY EXISTS OF EXPLOSION OR FIRE DUE TO STATIC ELECTRICITY.**

Figure 3. Pump Refueling

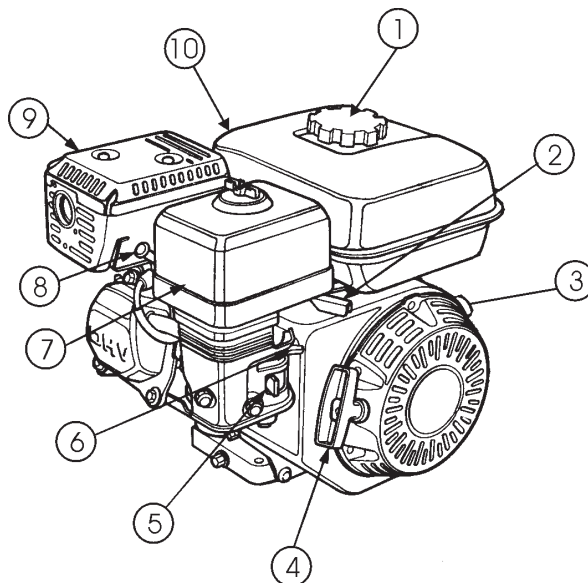

**Figure 4. Engine Controls and Components**

## INITIAL SERVICING

The engine (Figure 4) must be checked for proper lubrication and filled with fuel prior to operation. Refer to the manufacturer's engine manual for instructions and details of operation and servicing. The engine shown above is a **HONDA** engine, operation for other types of engines may vary somewhat.

1. **Fuel Filler Cap** – Remove this cap to add unleaded gasoline to the fuel tank. Make sure cap is tightened securely. **DO NOT** over fill.

**! CAUTION - Fueling The Engine**

Adding fuel to the tank should be done only when the engine is stopped and has had an opportunity to cool down. In the event of a fuel spill, **DO NOT** attempt to start the engine until the fuel residue has been completely wiped up, and the area surrounding the engine is dry.



2. **Throttle Lever** – Used to adjust engine RPM speed (lever advanced forward **SLOW**, lever back toward operator **FAST**).
3. **Engine ON/OFF Switch** – ON position permits engine starting, OFF position stops engine operations.
4. **Recoil Starter (pull rope)** – Manual-starting method. Pull the starter grip until resistance is felt, then pull briskly and smoothly.
5. **Fuel Valve Lever** – **OPEN** to let fuel flow, **CLOSE** to stop the flow of fuel.

6. **Choke Lever** – Used in the starting of a cold engine, or in cold weather conditions. The choke enriches the fuel mixture.
7. **Air Cleaner** – Prevents dirt and other debris from entering the fuel system. Remove wing-nut on top of air filter canister to gain access to filter element.

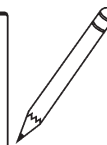
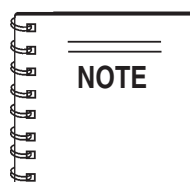

Operating the engine without an air filter, with a damaged air filter, or a filter in need of replacement will allow dirt to enter the engine, causing rapid engine wear.

8. **Spark Plug** – Provides spark to the ignition system. Set spark plug gap to 0.6 - 0.7 mm (0.028 - 0.031 inch) Clean spark plug once a week.
9. **Muffler** – Used to reduce noise and emissions.

**! CAUTION - Burn Hazard**

Engine components can generate extreme heat. To prevent burns, **DO NOT** touch these areas while the engine is running or immediately after operating. **NEVER** operate the engine with the muffler removed.



10. **Fuel Tank** – Holds unleaded gasoline. For additional information refer to engine owner's manual.

## Pre-Inspection (Engine)

1. Read safety instructions at the beginning of manual.
2. Clean the pump, removing dirt and dust, particularly the engine cooling air inlet, carburetor and air cleaner.
3. Check the air filter for dirt and dust. If air filter is dirty, replace air filter with a new one as required.
4. Check carburetor for external dirt and dust. Clean with dry compressed air.
5. Check fastening nuts and bolts for tightness.



## Engine Oil Check

1. To check the engine oil level, place the pump on secure level ground with the engine stopped.
2. Remove the filler dipstick from the engine oil filler hole (Figure 5) and wipe clean.

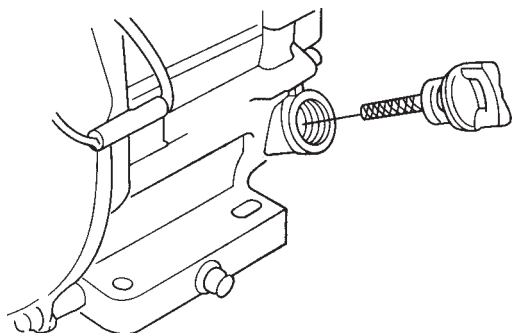

**Figure 5. Engine Oil Dipstick (Removal)**

3. Insert and remove the dipstick without screwing it into the filler neck. Check the oil level shown on the dipstick.
4. If the oil level is low (Figure 6), fill to the edge of the oil filler hole with the recommended oil type (Table 5). Maximum oil capacity is 1.16 quarts (1.1 liters)

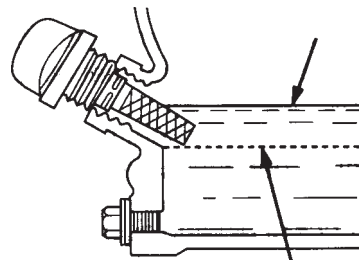

**Figure 6. Engine Oil Dipstick (Oil Level)**

**Table 5. Oil Type**

Season	Temperature	Oil Type
Summer	25°C or Higher	SAE 10W-30
Spring/Fall	25°C~10°C	SAE 10W-30/20
Winter	0°C or Lower	SAE 10W-10



## WARNING - Explosive Fuel

**Diesel** is extremely flammable, and its vapors can cause an explosion if ignited. **DO NOT** start the engine near spilled fuel or combustible fluids. **DO NOT** smoke while refueling. **DO NOT** attempt to refuel the pump if the engine is **hot!** or **running**.



## Fuel Check

1. Remove the gasoline cap located on top of fuel tank.
2. Visually inspect to see if the fuel level is low. If fuel is low, replenish with unleaded fuel.
3. When refueling, be sure to use a strainer for filtration. **DO NOT** top-off fuel. Wipe up any spilled fuel **immediately!**

## Pre-Setup (Pump)

1. Read safety instructions at the beginning of manual.
2. Place pump as near to water as possible, on a firm flat, level surface.
3. To prime pump, remove fill cap (Figure 2) and fill pump casing with water. If the pump casing is not filled with water before starting, it will not begin pumping.

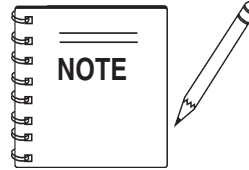

Suction and discharge hoses are available from Multiquip. Contact your nearest dealer for more information.

### CAUTION - Pump Casing

Pump casing **must** be filled with water before using pump. Otherwise pump will not be able to begin pumping.

### WARNING - High Pressure

**DO NOT** open **fill cap** if pump is **hot!** Water inside may be under pressure. The possibility exists of scalding, resulting in severe bodily harm.



### CAUTION - Strainer

The strainer should be positioned so it will remain completely **under water**. Running the pump with the strainer above water for long periods can damage the pump.

### CAUTION - Flammable Fluids-Chemicals

**DO NOT** pump flammable fluids, corrosive chemicals or fluids containing toxic substances. These fluids can create potentially dangerous health and environmental hazards. Contact local authorities for assistance.

4. Check for **leaks** between pump and engine. If water is leaking between the pump and engine housing, the seal inside the pump may be worn or damaged. Continued operation of the pump is not recommended. Further usage of the pump under these conditions may cause severe water damage to engine.

## Hoses and Clamps

1. Check that all hoses are **securely** attached to the pump. Make certain suction hose (Figure 2) does not have any air leakage. Tighten hose clamps and couplings as required.
2. It is recommended that 2 clamps be used when securing the suction hose to the inlet side (suction) of the pump.
3. Remember suction hoses must be **rigid** enough not to collapse when the pump is in operation.
4. Check that the **discharge** hose (Figure 2) is not restricted. Place hose so that it lays as straight as it is possible on the ground. Remove any twists or sharp bends from hose which may block the flow of water.

### CAUTION - Mechanical Seal

This pump uses a water-cooled **mechanical seal** to prevent water from seeping into the engine. The passage of water through the pump casing lubricates the seal and prevents it from overheating. **NEVER!** operate the pump without water in the casing as this will cause damage to the mechanical seal.

# QP-402H — INITIAL START-UP (ENGINE)

## CAUTION - Read Manual

**DO NOT** attempt to operate the pump until the Safety, General Information and Inspection sections of this manual have been **read and thoroughly understood**.



This section is intended to assist the operator with the **initial start-up** of the trash pump. It is extremely important that this section be read carefully before attempting to use the pump in the field.

### Starting the Engine (*HONDA* engine)

1. Place the engine **fuel valve lever** (Figure 7) to the "ON" position.

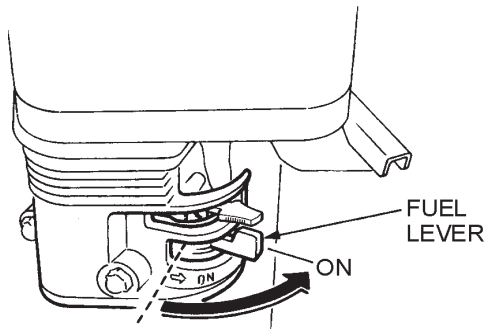

Figure 7. Engine Fuel Valve Lever (ON Position)

2. Move the **throttle lever** (Figure 8) away from the slow position, about 1/3 of the way toward the fast position.

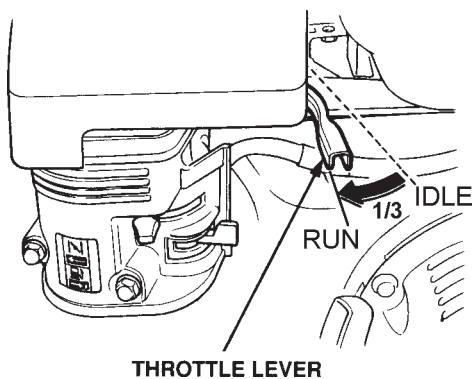

Figure 8. Throttle Lever (1/3 Start Position)

3. Place the **choke lever** (Figure 9) in the "CLOSED" position if starting a **cold** engine.

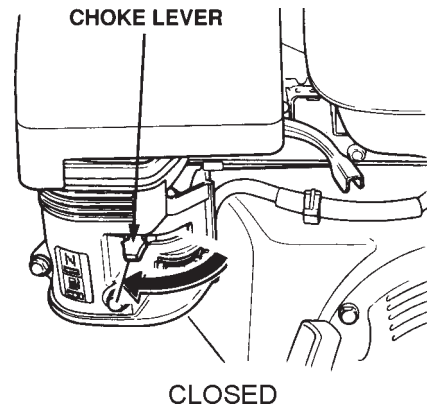

Figure 9. Engine Choke Lever (Closed)

4. Place the **choke lever** (Figure 10) in the "OPEN" position if starting a **warm engine** or the **temperature is warm**.

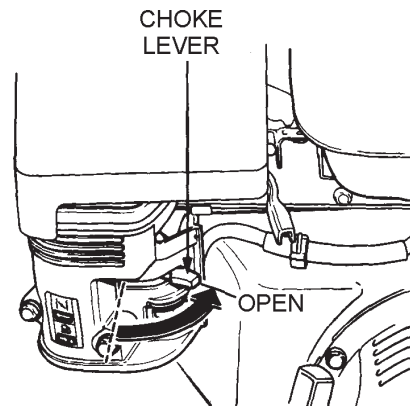

Figure 10. Engine Choke Lever (Open)

5. Place the **engine ON/OFF switch** (Figure 11) in the "ON" position.

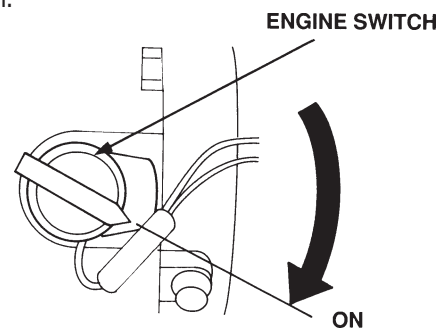

Figure 11. Engine ON/OFF Switch (ON Position)

## QP-402H — INITIAL START-UP (ENGINE)

- Grasp the starter grip (Figure 12) and slowly pull it out. The resistance becomes the hardest at a certain position, corresponding to the compression point. Pull the starter grip briskly and smoothly for starting.

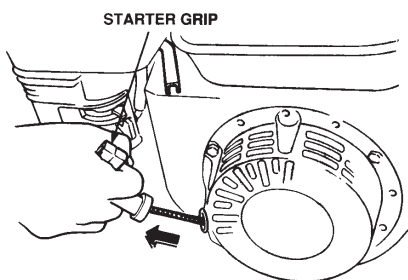

Figure 12. Starter Grip

- If the engine has started, and the choke lever was moved to the **CLOSED** position to start the engine, gradually move the choke lever lever to the **OPEN** position as the engine warms up. If the engine has not started repeat steps 1 through 6.

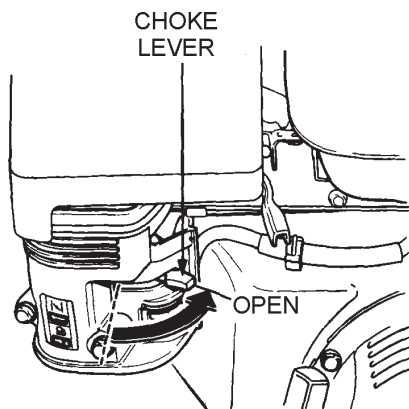

Figure 13. Choke Lever (Open)

- Before the pump is placed into operation, run the engine for several minutes. Check for fuel leaks, and noises that would associate with a lose component.
- To begin pumping, place the throttle lever (Figure 14) in the **"RUN" position**.

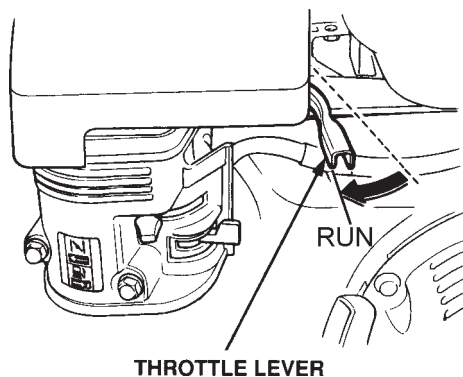

Figure 14. Throttle Lever (Run)

### **!** CAUTION - Maximum Engine Speed

**ALWAYS** run engine at **full speed** while pumping.

### Stopping The Engine

#### Normal Shutdown

- Move the throttle lever to the **IDLE** position (Figure 15) and run the engine for three minutes at low speed.

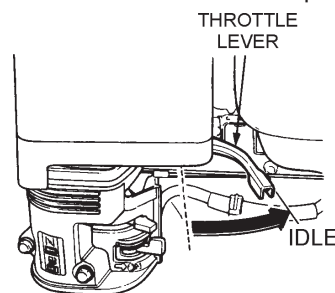

Figure 15. Throttle Lever (Idle)

- After the engine **cools**, turn the engine ON/OFF switch to the **"OFF"** position (Figure 16).

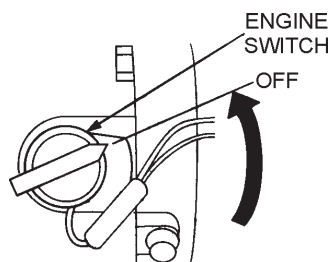

Figure 16. Engine ON/OFF Switch (OFF)

- Place the **fuel shut-off lever** (Figure 17) in the **OFF** position.

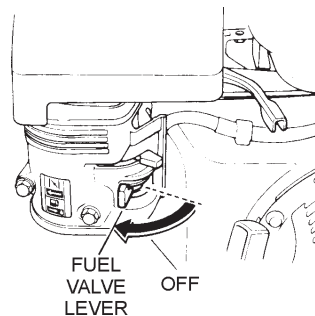

Figure 17. Fuel Valve Lever (OFF)

#### Emergency Showdown

- Move the throttle lever quickly to the **IDLE** position, and place the engine ON/OFF switch in the **OFF** position.

## Pump Vacuum Test

### CAUTION - Pump Priming

**DO NOT** attempt to start the engine unless the pump has previously been **primed** with water. Severe pump damage will occur if pump has not been primed.

To perform the pump vacuum test do the following:

1. Remove the pump fill cap (Figure 2), and fill the pump with water.
2. Start the engine as outlined in the initial start-up section, and wait for the pump to begin pumping.
3. As shown in Figure 18 (next page), place a water hose inside the discharge opening of the pump, and turn on the water. This flow of water into the discharge opening will **prevent** the pump from running dry.
4. Place the **Pump Vacuum Tester** (P/N 7000030) over the pump suction (inlet) opening (Figure 17) with the vacuum gauge facing upwards. It may be necessary to apply a small amount of water around the rubber seal of the vacuum tester to make a good suction fit.
5. Check and make sure that there are no air leaks between the vacuum tester and the inlet port on the pump. If air leaks are present reset vacuum tester.
6. Run the pump for a few minutes while monitoring the vacuum gauge. If the gauge indicates a reading between -25 and -20 in. Hg. (inches of mercury) then it can be assumed that the pump is working correctly.

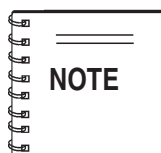

25 in. Hg (inches of mercury) translates into 25 feet of lift at **sea level**.

7. If the vacuum tester gauge indicates a reading **below** -20 in. Hg, it can then be assumed that the pump is not functioning correctly, and corrective action needs to be taken.
8. To test the **flapper valve**, shut down the engine. The vacuum tester should remain attached to the pump suction inlet port by vacuum. This indicates the pump's flapper valve is seating properly to hold water in the suction hose when the engine is stopped. This prevents backflow and allows for faster priming when the engine is restarted.

**CAUTION**  
DO NOT RUN PUMP  
WITHOUT WATER.

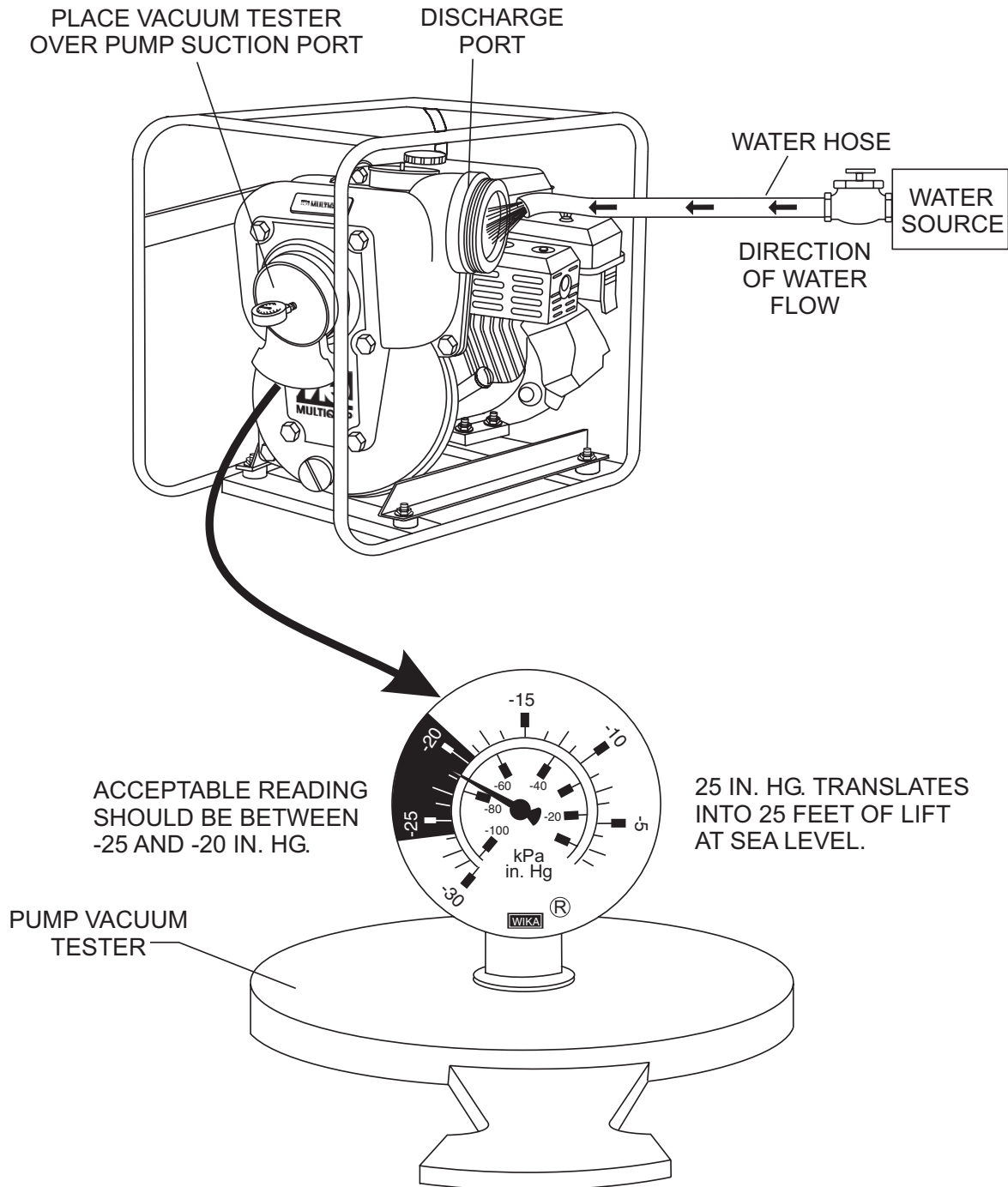

Figure 18. Pump Vacuum Tester

## Engine Maintenance

Perform engine maintenance procedures as referenced by Table 6 below:

Table 6. Engine Maintenance Schedule							
DESCRIPTION (3)	OPERATION	BEFORE	FIRST MONTH OR 10 HRS.	EVERY 3 MONTHS OR 25 HRS.	EVERY 6 MONTHS OR 50 HRS.	EVERY YEAR OR 100 HRS.	EVERY 2 YEARS OR 200 HRS.
Engine Oil	CHECK	X					
	CHANGE		X				
Air Cleaner	CHECK	X					
	CHANGE			X (1)			
All Nuts & Bolts	Re-tighten If Necessary	X					
Spark Plug	CHECK-CLEAN				X		
	REPLACE						X
Cooling Fins	CHECK				X		
Spark Arrester	CLEAN					X	
Fuel Tank	CLEAN					X	
Fuel Filter	CHECK					X	
Idle Speed	CHECK-ADJUST					X (2)	
Valve Clearance	CHECK-ADJUST						X (2)
Fuel lines	CHECK	Every 2 years (replace if necessary) (2)					

(1) Service more frequently when used in **DUSTY** areas.

(2) These items should be serviced by your servic dealer, unless you have the proper tools and are mechanically proficient. Refer to the HONDA shop Manual for service procedures

(3) For commercial use, log hours of operation to determine proper maintenance intervals.

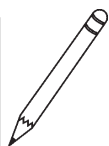
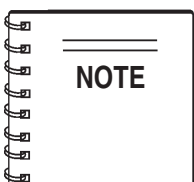

Reference manufacturer engine manual for specific servicing instructions.

## MAINTENANCE

Perform the engine maintenance procedures as indicated below:

### DAILY

- Thoroughly remove dirt and oil from the engine and control area. Clean or replace the air cleaner elements as necessary. Check and retighten all fasteners as necessary. Check the spring box and bellows for oil leaks. Repair or replace as needed.

### WEEKLY

- Remove the fuel filter cap and clean the inside of the fuel tank.
- Remove or clean the filter at the bottom of the tank.
- Remove and clean the spark plug (Figure 19), then adjust the spark gap to 0.028 ~0.031 inch (0.6~0.7 mm). This unit has electronic ignition, which requires no adjustments.

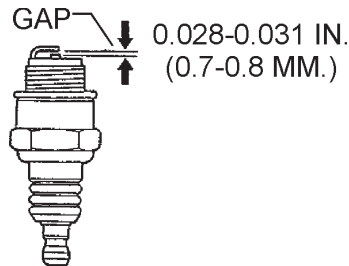

Figure 19. Spark Plug Gap

### ENGINE OIL

1. Drain the engine oil when the oil is **warm** as shown in Figure 20.
2. Remove the oil drain bolt and sealing washer and allow the oil to drain into a suitable container.
3. Replace engine oil with recommended type oil as listed in Table 5. Engine oil capacity is 1.16 quarts (1.1 liters). **DO NOT** overfill.
4. Install drain bolt with sealing washer and tighten securely.

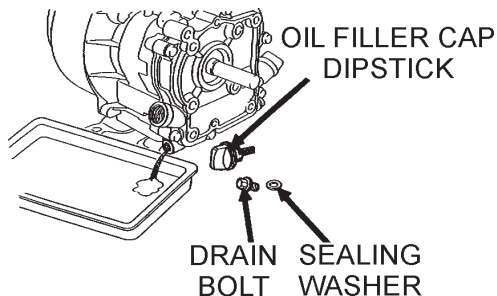

Figure 20. Engine Oil (Draining)

## DANGER - Cleaning Solvents

The **DO NOT** use gasoline as a cleaning solvent, because that would create a risk of fire or explosion.



### ENGINE AIR CLEANER

1. Remove the air cleaner cover and foam filter element as shown in Figure 21.
2. Tap the paper filter element (Figure 21) several times on a hard surface to remove dirt, or blow compressed air [not exceeding 30 psi (207 kPa, 2.1 kgf/cm<sup>2</sup>)] through the filter element from the air cleaner case side. **NEVER** brush off dirt. Brushing will force dirt into the fibers. Replace the paper filter element if it is excessively dirty.
3. Clean foam element in warm, soapy water or nonflammable solvent. Rinse and dry thoroughly. Dip the element in clean engine oil and completely squeeze out the excess oil from the element before installing.

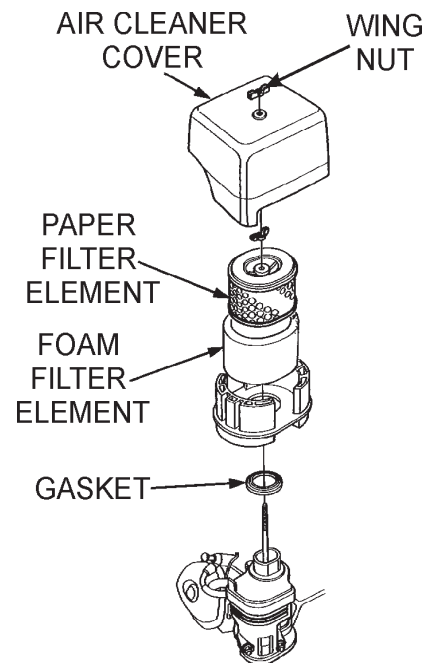

Figure 21. Engine Air Cleaner

### Pump Storage

For storage of the pump for over 30 days, the following is required:

- Drain the fuel tank completely.
- Run the engine until the fuel in the carburetor is completely consumed.
- Completely drain used oil from the engine crankcase and fill with fresh clean oil, then follow the procedures described in the engine manual for engine storage.
- Remove the drain plug from the pump and drain out any water from left in the housing.
- Remove the pump cover and clean inside of pump housing. Coat inside of pump housing with a light film of oil to reduce corrosion. A spray can of oil works well for this application.
- Cover suction and discharge ports with duct tape to prevent any foreign matter from falling into pump.
- Cover pump and engine with plastic covering or equivalent and store in a clean, dry place.
- To protect the water cooled-seals, place one-half pint of lubricating oil (new or used) through the discharge opening on the pump and crank the engine several times. This will prevent excessive corrosion and also keep the mechanical seal lubricated.



# QP-402H — TROUBLESHOOTING (ENGINE)

**TABLE 7. ENGINE TROUBLESHOOTING**

SYMPTOM	POSSIBLE PROBLEM	SOLUTION
<b>Difficult to start</b>		
Fuel is available but spark plug will not ignite. (Power available at high tension cable).	Ignition plug being bridge?	Check ignition system.
	Carbon deposit at ignition?	Clean or replace ignition.
	Short circuit due to defective insulators?	Replace insulators.
	Improper spark gap?	Set spark plug gap to the correct gap.
Fuel is available but spark plug will not ignite. (Power <b>NOT</b> available at high tension cable).	Short circuit at stop switch?	Check stop switch circuit. Replace stop switch if defective.
	Ignition coil defective?	Replace ignition coil.
Fuel is available and spark plug ignites (compression <b>normal</b> ).	Muffler clogged with carbon deposits?	Clean or replace muffler.
	Mixed fuel quality is inadequate?	Check fuel to oil mixture.
	Fuel in use inadequate (water, dust)?	Flush fuel sytem and replace with fresh fuel.
	Air Cleaner clogged?	Clean or replace air cleaner.
Fuel is available and spark plug ignites (compression <b>low</b> ).	Defective cylinder head gasket?	Tighten cylinder head bolts or replace head gasket.
	Cylinder worn?	Replace cylinder.
	Spark plug loose?	Tighen spark plug.
<b>Operation not satisfactory</b>		
Not enough power available (compression normal, no miss-firing).	Air cleaner clogged?	Clean or replace air cleaner.
	Air in fuel line?	Bleed (remove air) from fuel line.
	Fuel level in carbureator float chamber improper?	Adjust carbureator float
	Carbon deposits in cylinder?	Clean or replace cylinder
Not enough power available (compression normal, miss-firing).	Ignition coil defective?	Flush fuel sytem and replace with fresh fuel.
	Ignition plug often shorts?	Replace ignition wires, clean ignition.
	Fuel in use inadequate (water, dust)?	Flush fuel sytem and replace with fresh fuel.
Engine overheats.	Excessive carbon depostion in combustion chamber?	Clean or replace crankcase.
	Exhaust or muffler clogged with carbon.	Clean or replace muffler.
	Spark plug heat value incorrect?	Replace spark plug with correct type spark plug.

# QP-402H — TROUBLESHOOTING (ENGINE/PUMP)

## TABLE 7. ENGINE TROUBLESHOOTING (Continued)

SYMPTOM	POSSIBLE PROBLEM	SOLUTION
<b>Operation not satisfactory</b>		
Rotational speed fluctuates.	Governor adjustment improper?	Adjust governor to correct lever.
	Governor spring defective?	Clean or replace ignition.
	Fuel flow erratic?	Check fuel line.
	Air taken in through suction line?	Check suction line.
Recoil starter not working properly.	Dust in rotating part?	Clean recoil starter assembly.
	Spring spring failure?	Replace sprial spring.

## TABLE 8. PUMP TROUBLESHOOTING

SYMPTOM	POSSIBLE PROBLEM	SOLUTION
Pump does not take on water.	Not enough priming water in the housing?	Add water.
	Engine speed too low?	Increase throttle.
	Strainer plugged?	Clean strainer.
	Suction hose damaged?	Replace or repair hose, and clamps
	Air leak at suction port?	Check that fittings are tight and properly sealed.
	Pump is located too high above water line?	Move pump closer to water.
	Debris collecting in pump housing?	Clean pump housing.
	Too much distance between impeller and volute.	Adjust clearance by adding shims or replace impeller. Min. .006" - Max. .020"
	Water leaking out weep hole between pump and engine?	Check condition of mechanical seal and gaskets, between pump end and engine housing.
Pump takes in water, little or no discharge.	Engine speed too low?	Increase throttle speed.
	Suction strainer partially plugged?	Clean strainer.
	Impeller/Volute worn?	Adjust clearance by adding shims or replace impeller/volute
Suction hose leaks at inlet.	Fittings/clamps are not sealed properly?	Tighten, replace or add clamp. (Keep extra seals on pump)
	Hose diameter is too large?	Use smaller diameter hose or replace hose.
Discharge does not stay on coupling.	Pressure too high?	Check pressure, add additional clamp.
	Hose kinked or end blocked?	Check hose.
Impeller does not turn: pump is hard to start.	Impeller jammed or blocked?	Open pump cover and clean dirt and debris from inside housing.
	Impeller and volute binding?	Adjust clearance by removing shim from behind impeller.
	Defective engine?	See Engine Owner's Manual.

# QP-402H — EXPLANATION OF CODE IN REMARKS COLUMN

The following section explains the different symbols and remarks used in the Parts section of this manual. Use the help numbers found on the back page of the manual if there are any questions.

The contents and part numbers listed in the parts section are subject to change **without notice**. Multiquip does not guarantee the availability of the parts listed.

Sample Parts List:

NO.	PART NO.	PART NAME	QTY.	REMARKS
1	12345	BOLT .....	1	INCLUDES ITEMS W/*
2*		WASHER, 1/4 IN. ....		NOT SOLD SEPARATELY
2*	12347	WASHER, 3/8 IN. ... 1		MQ-45T ONLY
3	12348	HOSE .....	A/R	MAKE LOCALLY
4	12349	BEARING .....	1	S/N 2345B AND ABOVE

## NO. Column

**Unique Symbols** - All items with same unique symbol (\*, #, +, %, or >) in the number column belong to the same assembly or kit, which is indicated by a note in the "Remarks" column.

**Duplicate Item Numbers** - Duplicate numbers indicate multiple part numbers are in effect for the same general item, such as different size saw blade guards in use or a part that has been updated on newer versions of the same machine.

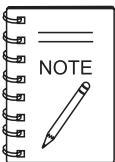

When ordering a part that has more than one item number listed, check the remarks column for help in determining the proper part to order.

## PART NO. Column

**Numbers Used** - Part numbers can be indicated by a number, a blank entry, or TBD.

TBD (To Be Determined) is generally used to show a part that has not been assigned a formal part number at time of publication.

A blank entry generally indicates that the item is not sold separately or is not sold by Multiquip. Other entries will be clarified in the "Remarks" Column.

## QTY. Column

**Numbers Used** - Item quantity can be indicated by a number, a blank entry, or A/R.

A/R (As Required) is generally used for hoses or other parts that are sold in bulk and cut to length.

A blank entry generally indicates that the item is not sold separately. Other entries will be clarified in the "Remarks" Column.

## REMARKS Column

Some of the most common notes found in the "Remarks" Column are listed below. Other additional notes needed to describe the item can also be shown.

**Assembly/Kit** - All items on the parts list with the same unique symbol will be included when this item is purchased.

Indicated by:

"INCLUDES ITEMS W/(unique symbol)"

**Serial Number Break** - Used to list an effective serial number range where a particular part is used.

Indicated by:

"S/N XXXXX AND BELOW"

"S/N XXXX AND ABOVE"

"S/N XXXX TO S/N XXX"

**Specific Model Number Use** - Indicates that the part is used only with the specific model number or model number variant listed. It can also be used to show a part is NOT used on a specific model or model number variant.

Indicated by:

"XXXXX ONLY"

"NOT USED ON XXXX"

**"Make/Obtain Locally"** - Indicates that the part can be purchased at any hardware shop or made out of available items. Examples include battery cables, shims, and certain washers and nuts.

**"Not Sold Separately"** - Indicates that an item cannot be purchased as a separate item and is either part of an assembly/kit that can be purchased, or is not available for sale through Multiquip.

## QP-402H CENTRIFUGAL PUMP 1 TO 3 UNITS WITH HONDA GX240K1PMT2/GX240U1PMT2 ENGINE(S)

Qty.	P/N	Description
3	KIT402H.....	KIT, PUMP
2	0631211100 .....	DRAIN CAP, FLOODING
2	0480350300 .....	O-RING DRAIN CAP
1	1424000030 .....	IMPELLER
3	17210ZE2822.....	ELEMENT AIR CLEANER DUAL
3	9807956846 .....	SPARK PLUG
3	9807955855 .....	SPARK PLUG
3✕	2846ZE2W01 .....	ROPE STARTER, S/N 3793540 AND BELOW
3✕	2846ZE2W11 .....	ROPE STARTER, S/N 3793541 AND ABOVE
3◇	2846ZE2W11 .....	ROPE STARTER
1✕	17620ZH7023.....	CAP, FUEL WITH GASKET
1◇	17620Z0T305 .....	CAP, FUEL WITH GASKET

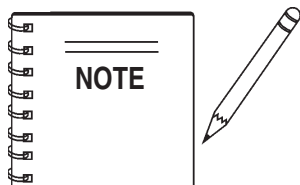

Part number on this Suggested Spare Parts List may super cede/replace the P/N shown in the text pages of this book.

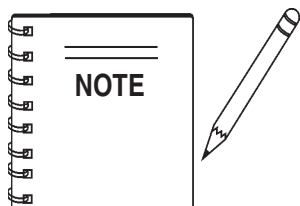

✕ GX240K1PMTNH1: Model QP-402H S/N 402H-0417 AND BELOW  
 ◇ GX240U1PMTNH1: Model QP-402H S/N 402H-0418 AND ABOVE

## PUMP ASSY.

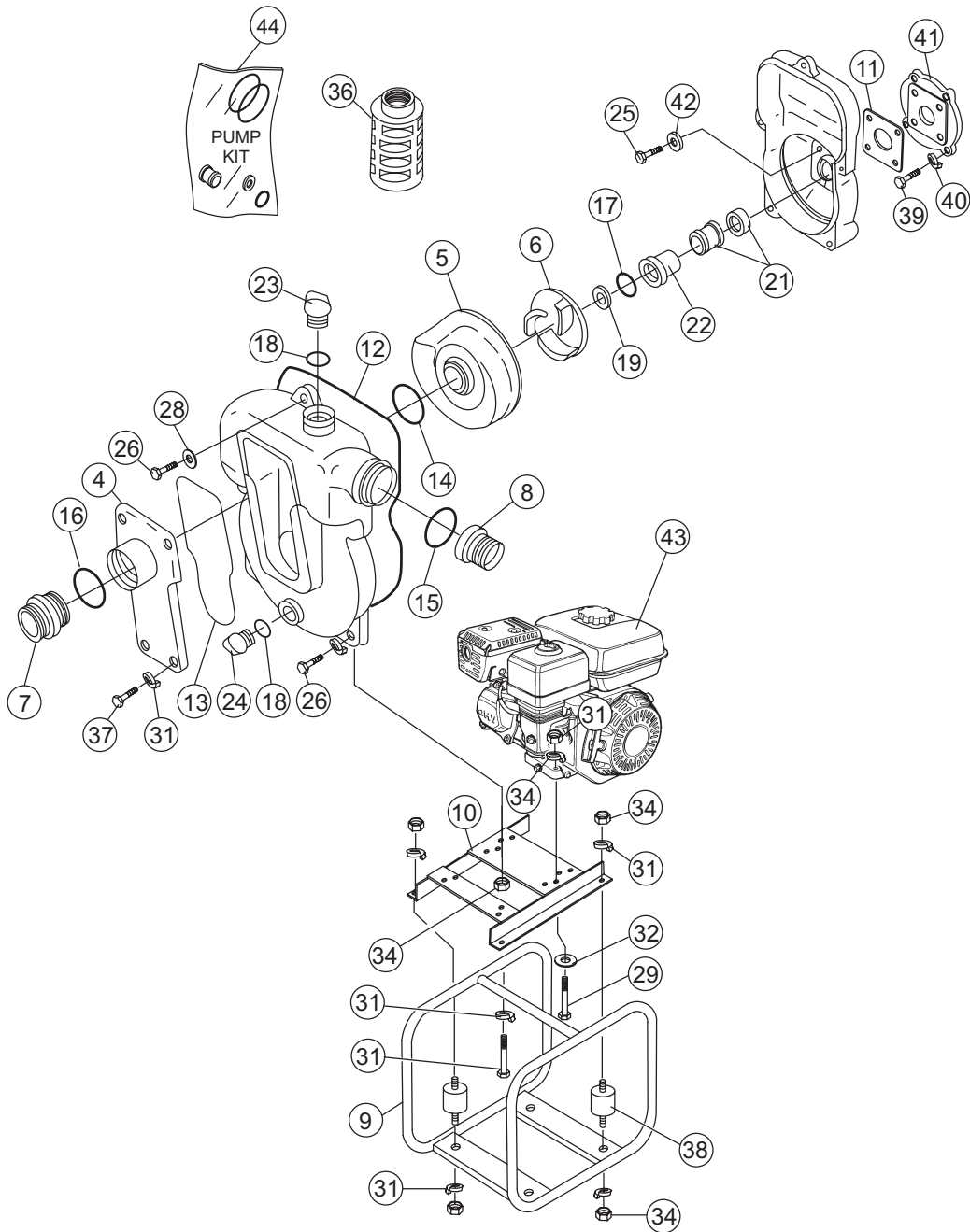

# QP-402H — PUMP ASSY.

PUMP ASSY.

<u>NO.</u>	<u>PART NO.</u>	<u>PART NAME</u>	<u>QTY.</u>	<u>REMARKS</u>
2	9430100010	CASING	1	
3	9430100020	CASING COVER .....	1	REPLACES 0430100020
4	9430100160	SUCTION COVER	1	
5	9430000130	VOLUTE CASING	1	
6	1424000030	IMPELLER .....	1	REPLACES 1401000030
7	0790434040	NIPPLE, NPS4"XNPT4" .....	1	REPLACES 1424101800
8	0798934040	SOCKET, M100XNPT4" .....	1	REPLACES 1424102200
9	1353214011	BASE	1	
10	1975214020	ENGINE BASE	1	
11	1317390610	CASING COVER PACKING	1	
12%	0489353850	O-RING (CASING) DIA.3.5 X 385	1	
13	0489352380	O-RING (SUCTION COVER), DIA.3.5 X 238	1	
14%	0481310950	O-RING (VOLUTE CASING), G95	1	
15	0481311000	O-RING (SOCKET), G100	1	
16	0481311100	O-RING (NIPPLE), G110	1	
17%	0481310250	O-RING (MECHANICAL SEAL SLEEVE), G25	1	
18	0480350300	O-RING (FLOODING CAP), P30	2	
19%	0852834525	ADJUST LINER, DIA. 45X25 t0.3 .....	1	REPLACES 7852833020
19%	0852854525	ADJUST LINER, DIA. 45X25 t0.5 .....	1	REPLACES 7852853020
20	9430350350	CHECK VALVE	1	
21%	0806113630	MECHANICAL SEAL, HK9A-LN DIA. 30 .....	1SET	REPLACES 0801113530
22%	0811883056	MECH. SEAL SLEEVE, DIA. 1"XDIA 30 X56 .....	1	REPLACES 0811253056
23	0631211100	FLOODING CAP, PF1"	1	
24	0631211100	DRAIN CAP, W/ O-RING, PF1"	1	
25	0105050820	BOLT, CASING COVER M8X20	4	
26	0105051240	BOLT, CASING M12X40 .....	4	REPLACES 0181051240
27	0105051250	BOLT, CASING M12X50 .....	1	REPLACES 0181051250
28	0451250120	WASHER, LOCK M12	5	
29	0105051045	BOLT, ENGINE M10X45	4	
30	0105051035	BOLT, PUMP M10X35	2	
31	0451250100	WASHER, LOCK M10	20	
32	0401450100	WASHER, M10	4	
33	0401450060	WASHER, M6 .....	2	REPLACES 0401650060
34	0205450100	NUT, ENGINE CUSHION RUBBER M10	14	
35	0141090616	SCREW, CHECK ENGINE M6X16	2	
36	0742213100	STRAINER, NPT4" .....	1	REPLACES 0742063100
37	0105051040	BOLT, SUCTION COVER M10X40 .....	6	REPLACES 0181051040
38	0723302040	CUSHION RUBBER, DIA. 40 H20 M10	4	
39	0191160625	BOLT, SET PLATE 3/8-16UNCX25	4	
40	0451250100	WASHER, LOCK M10	4	
41	4313000600	CASING COVER SET PLATE	1	
42	0458220080	SEAL WASHER, M8	4	
43	GX240U1PMT2	ENGINE, 5.5 HP	1	
44	KIT402H	KIT, PUMP .....	1	INCLUDES ITEMS W/%

# HONDA GX240K1PMT2/GX240U1PMT2 ENG. — AIR CLEANER (DUAL) ASSY.

AIR CLEANER (DUAL) ASSY.

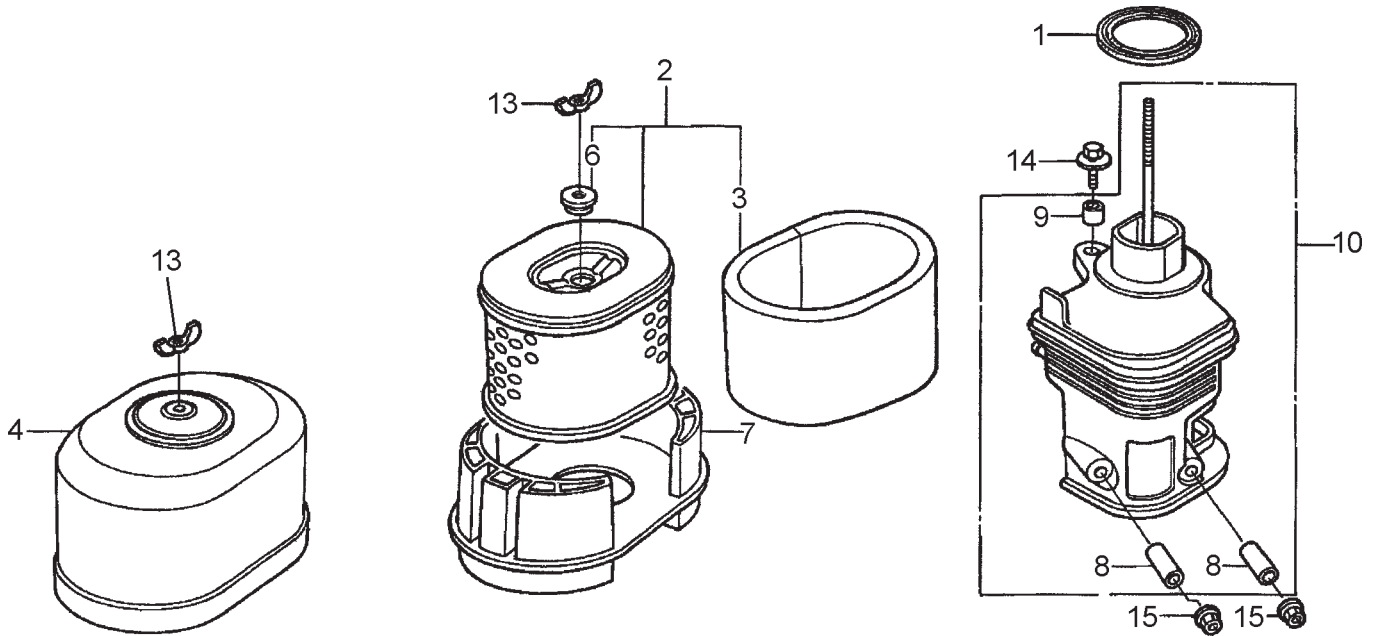

# HONDA GX240K1PMT2/GX240U1PMT2 ENG. — AIR CLEANER (DUAL) ASSY.

## AIR CLEANER (DUAL) ASSY.

<u>NO.</u>	<u>PART NO.</u>	<u>PART NAME</u>	<u>QTY.</u>	<u>REMARKS</u>
1✖	16271ZE2000	GASKET, ELBOW	1	
1◇	16271ZE2010	GASKET, ELBOW	1	
2	17210ZE2822	ELEMENT, AIR CLEANER (DUAL) .....	1	INCLUDES ITEMS W/%
3%	17218ZE2821	FILTER, OUTER	1	
4	17230ZE2820	COVER, AIR CLEANER (DUAL)	1	
6%	17232891000	GROMMET, AIR CLEANER	1	
7	17235ZE2820	NOSE, MUFFLER	1	
8*	17238ZE2310	COLLAR, AIR CLEANER	2	
9*	17239ZE1000	COLLAR B, AIR CLEANER	1	
10	17410ZE2020	ELBOW, AIR CLEANER .....	1	INCLUDES ITEMS W/*
13	90325044000	WINGNUT, TOOL BOX SETTING	2	
14	934940602008	BOLT- WASHER 6X20	1	
15	9405006000	NUT, FLANGE 6MM	2	

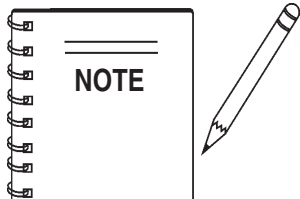

- ✖ GX240K1PMTNH1: Model QP-402H S/N 402H-0417 AND BELOW
- ◇ GX240U1PMTNH1: Model QP-402H S/N 402H-0418 AND ABOVE

# HONDA GX240K1PMT2/GX240U1PMT2 ENG. — CAMSHAFT ASSY.

CAMSHAFT ASSY.

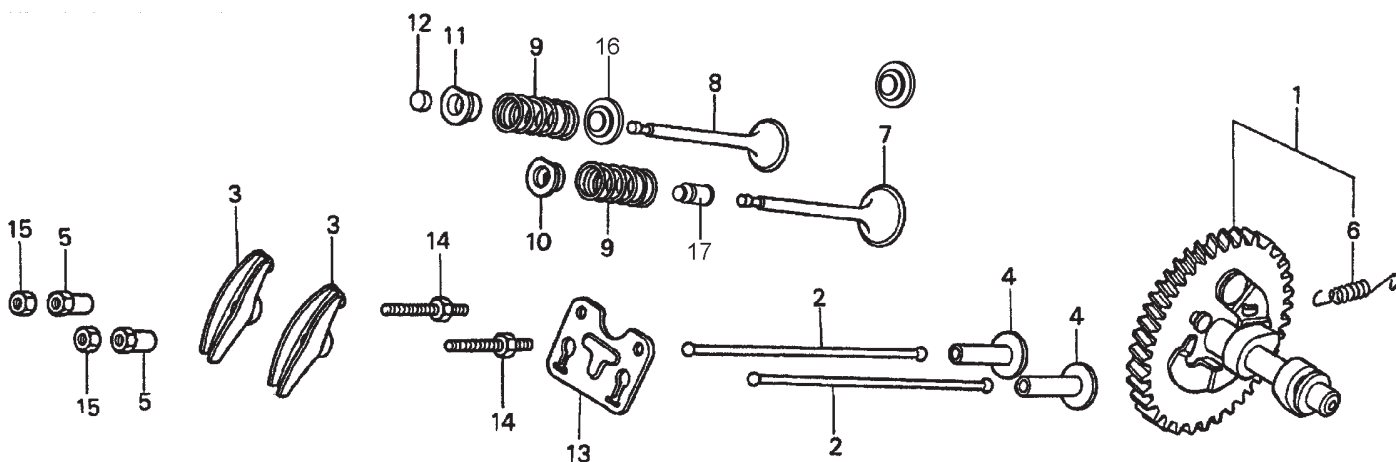

# HONDA GX240K1PMT2/GX240U1PMT2 ENG. — CAMSHAFT ASSY.

## CAMSHAFT ASSY.

<b>NO.</b>	<b>PART NO.</b>	<b>PART NAME</b>	<b>QTY.</b>	<b>REMARKS</b>
1✘	14100ZE2W00	CAMSHAFT ASSEMBLY .....	1	INCLUDES ITEM W/#
1✘	14100ZE2W01	CAMSHAFT ASSEMBLY .....	1	INCLUDES ITEM W/#
1◇	14100ZE2W01	CAMSHAFT ASSEMBLY .....	1	INCLUDES ITEM W/#
2	14410ZE2013	ROD, PUSH	2	
3	14431ZE2010	ARM, VALVE ROCKER	2	
4	14441ZE2000	LIFTER, VALVE	2	
5	14451ZE1013	PIVOT, ROCKER ARM	2	
6#	14568ZE1000	SPRING, WEIGHT RETURN	1	
7	14711ZE2000	VALVE, INTAKE	1	
8	14721ZE2000	VALVE, EXHAUST	1	
9	14751ZE2003	SPRING, VALVE	2	
10	14771ZE2000	RETAINER, INTAKE VALVE SPRING	1	
11	14773ZE2000	RETAINER, EXHAUST VALVE SPRING	1	
12	14781ZE2000	ROTATOR, VALVE	1	
13	14791ZE2010	PLATE, PUSH ROD GUIDE	1	
14	90012ZE0010	BOLT, PIVOT 8MM	2	
15	90206ZE1000	NUT, PIVOT ADJ.	2	
16◇	14775ZE2010	SEAT, VALVE SPRING	1	
17✘	12209ZE8003	SEAL, VALVE STEM .....	1	S/N 4081305 AND ABOVE
17◇	12209ZE8003	SEAL, VALVE STEM	1	

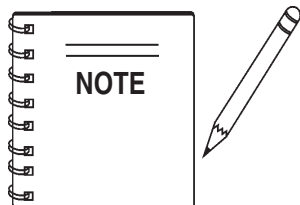

- ✘ GX240K1PMTNH1: Model QP-402H S/N 402H-0417 AND BELOW
- ◇ GX240U1PMTNH1: Model QP-402H S/N 402H-0418 AND ABOVE

# HONDA GX240K1PMT2/GX240U1PMT2 ENG. — CARBURETOR ASSY.

CARBURETOR ASSY.

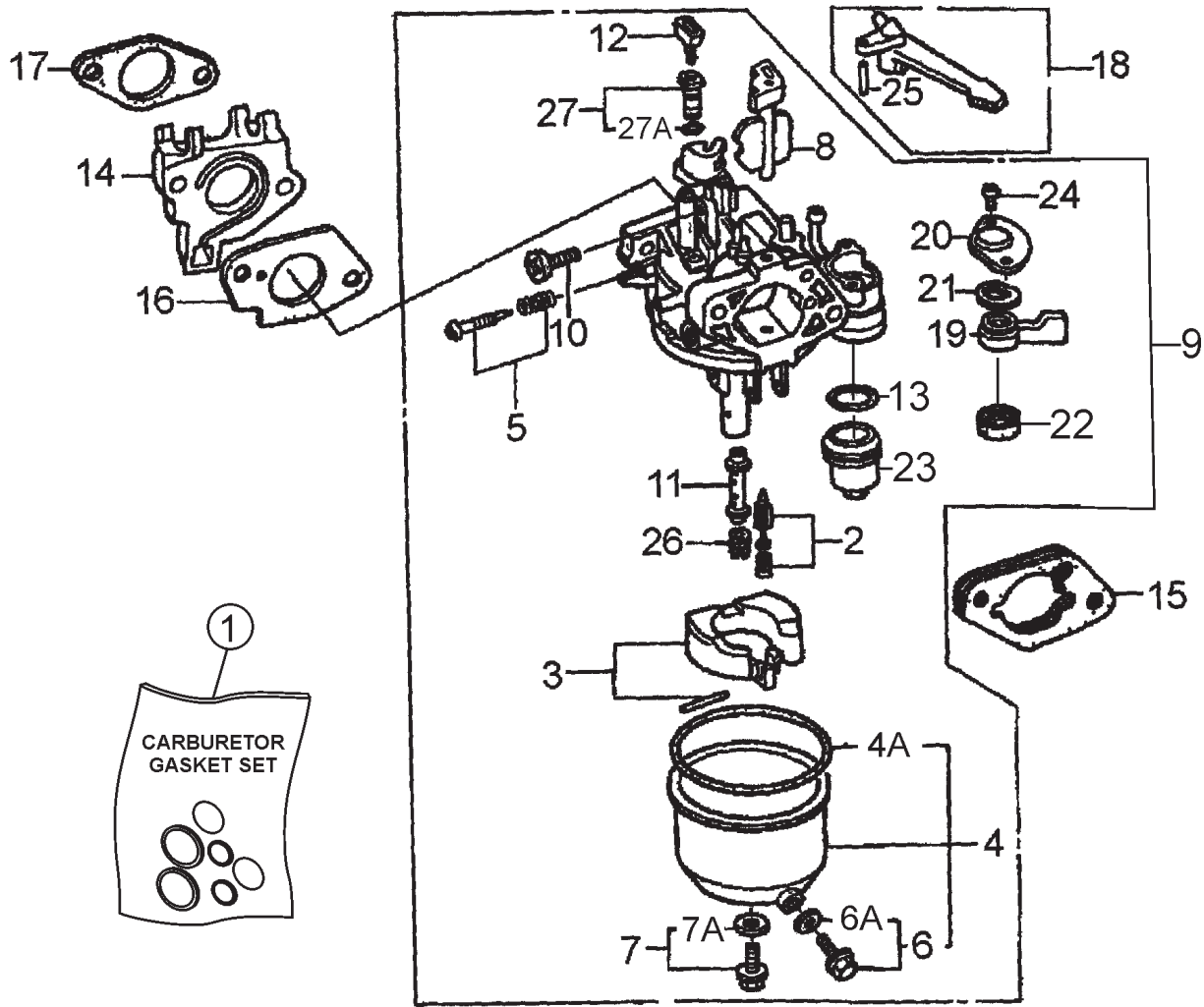

# HONDA GX240K1PMT2/GX240U1PMT2 ENG. — CARBURETOR ASSY.

## CARBURETOR ASSY.

NO.	PART NO.	PART NAME	QTY.	REMARKS
1	16010ZE2812	CARBURETOR, GASKET SET .....	1	INCLUDES ITEM W/+
2\$%#	16011ZA0931	VALVE SET, FLOAT	1	
3\$%#	16013ZA0931	FLOAT SET	1	
4x\$	16015ZE2005	CHAMBER SET, FLOAT .....	1	INCLUDES ITEM 4A INCLUDES ITEM W/> S/N BE70B A AND BELOW
4x%	16015ZE8005	CHAMBER SET, FLOAT .....	1	INCLUDES ITEM 4A INCLUDES ITEM W/> S/N BE70B B AND ABOVE
4◇#	16015ZE8005	CHAMBER SET, FLOAT .....	1	INCLUDES ITEM 4A INCLUDES ITEM W/>
4A+		GASKET, CHAMBER SET, FLOAT .....	1	NOT SOLD SEPARATELY
5\$%#	16016ZH7W01	SCREW SET, PILOT	1	
6\$%#>	16024ZE1811	SCREW SET, DRAIN .....	1	INCLUDES ITEM 6A
6A+		GASKET, SCREW SET, DRAIN .....	1	NOT SOLD SEPARATELY
7\$%#	16028ZE0005	SCREW SET .....	1	INCLUDES ITEM 7A
7A+		GASKET, SCREW SET .....	1	NOT SOLD SEPARATELY
8\$%#	16044ZE2005	CHOKE SET	1	
9x	16100ZE2W70	CARBURETOR ASSY., BE70B A .....	1	INCLUDES ITEMS W/\$ S/N 3453330 AND BELOW
9x	16100ZE2W71	CARBURETOR ASSY, BE70B B/C .....	1	INCLUDES ITEMS W/% S/N 3453331 AND ABOVE
9◇	16100ZE2W71	CARBURETOR ASSY, BE70B B .....	1	INCLUDES ITEMS W/#
10\$%#	16124ZE0005	SCREW, THROTTLE STOP	1	
11\$%#	16166ZE2W70	NOZZLE, MAIN	1	
12\$%#	16172ZE3W10	COLLAR, SET	1	
13\$%#+	16173001004	GASKET, FUEL STRAINER CUP	1	
14	16211ZE2000	INSULATOR, CARBURETOR	1	

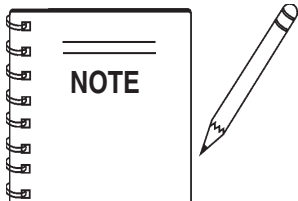

- x GX240K1PMTNH1: Model QP-402H S/N 402H-0417 AND BELOW
- ◇ GX240U1PMTNH1: Model QP-402H S/N 402H-0418 AND ABOVE

# HONDA GX240K1PMT2/GX240U1PMT2 ENG. — CARBURETOR ASSY.

CARBURETOR ASSY.

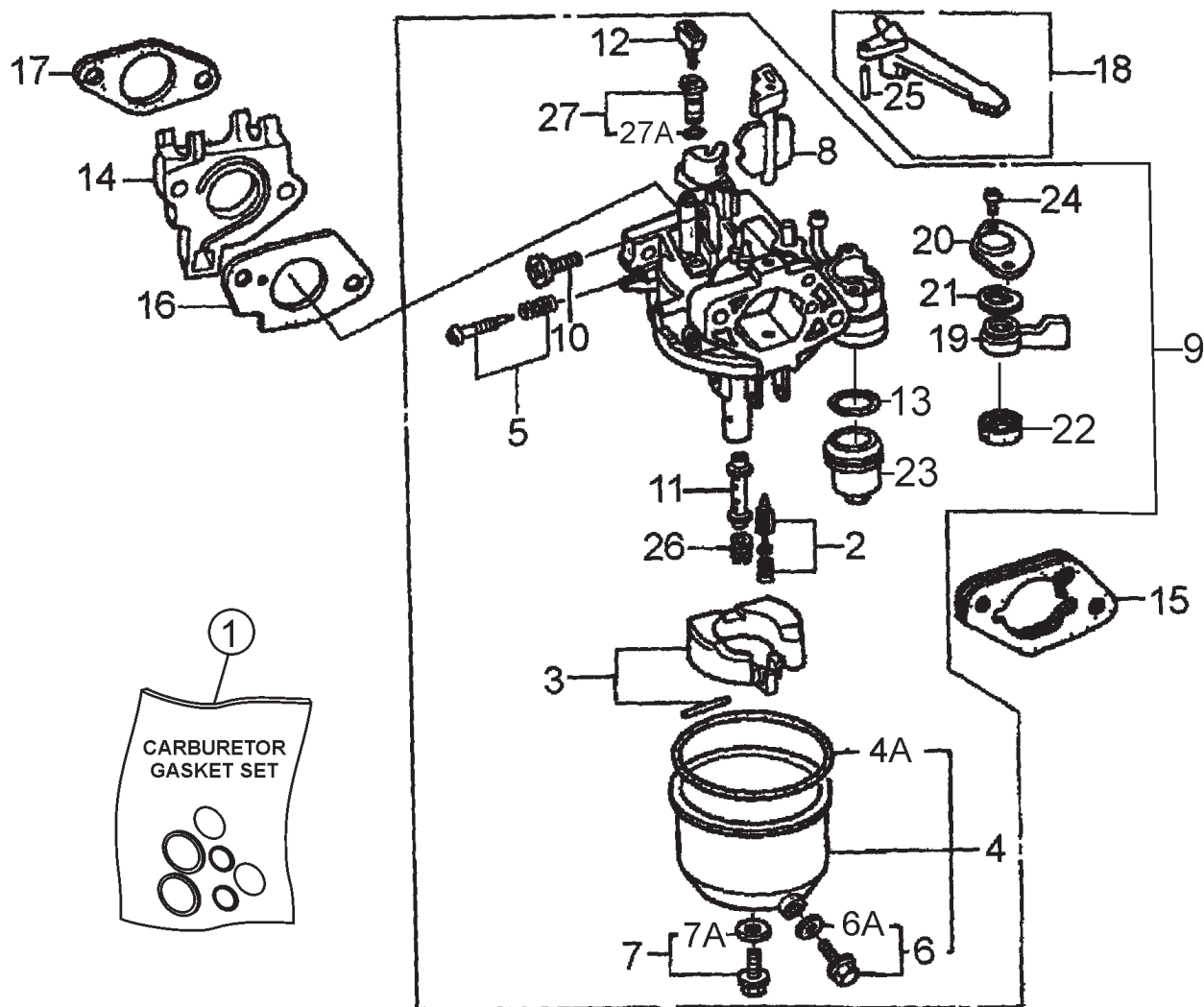

# HONDA GX240K1PMT2/GX240U1PMT2 ENG. — CARBURETOR ASSY.

## CARBURETOR ASSY.

<u>NO.</u>	<u>PART NO.</u>	<u>PART NAME</u>	<u>QTY.</u>	<u>REMARKS</u>
15	16220ZA0702	SPACER, CARBURETOR	1	
16	16221ZA0800	GASKET, CARBURETOR	1	
17	16223ZA0800	GASKET, INSULATOR	1	
18	16610ZE1000	LEVER, COMPLETE, CHOKE (STD) ..	1	INCLUDES GASKET
19\$%#	16953ZE1812	LEVER, COCK	1	
20\$%#	16954ZE1812	PLATE, LEVER SETTING	1	
21\$%#	16956ZE1811	SPRING, VALVE LEVER	1	
22\$%#+	16957ZE1812	GASKET, VALVE	1	
23\$%#	16967ZE0811	CUP, FUEL STRAINER	1	
24\$%#	93500030061H	SCREW, PAN 3X6	2	
25	9430520122	PIN, SPRING 2X12	1	
26✖	99101ZH70820	JET, MAIN #82 (OPTIONAL) .....	1	S/N BE70B A AND BELOW
26✖	99101ZH80820	JET, MAIN #82 (OPTIONAL) .....	1	S/N BE70B B AND ABOVE
26◇	99101ZH80820	JET, MAIN #82 (OPTIONAL)	1	
26✖	99101ZH70850	JET, MAIN #85 (OPTIONAL) .....	1	S/N BE70B A AND BELOW
26✖	99101ZH80850	JET, MAIN #85 (OPTIONAL) .....	1	S/N BE70B B AND ABOVE
26◇	99101ZH80850	JET, MAIN #85 (OPTIONAL)	1	
26✖	99101ZH70880	JET, MAIN #88 .....	1	S/N BE70B A AND BELOW
26✖	99101ZH80880	JET, MAIN #88 .....	1	S/N BE70B B AND ABOVE
26◇	99101ZH80880	JET, MAIN #88	1	
27✖	99204ZA00400	JET SET, PILOT #40 .....	1	S/N BE70B C AND ABOVE INCLUDES GASKET
27✖	99204ZE00400	JET SET, PILOT #40 .....	1	S/N BE70B B AND ABOVE INCLUDES GASKET
27✖	99204ZE20400	JET SET, PILOT #40 .....	1	S/N BE70B A AND BELOW INCLUDES GASKET
27◇	99204ZE00400	JET SET, PILOT #40 .....	1	INCLUDES GASKET
27A+		GASKET, JET SET, PILOT #40 .....	1	NOT SOLD SEPARATELY

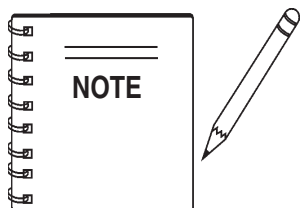

- ✖ GX240K1PMTNH1: Model QP-402H S/N 402H-0417 AND BELOW
- ◇ GX240U1PMTNH1: Model QP-402H S/N 402H-0418 AND ABOVE



# HONDA GX240K1PMT2/GX240U1PMT2 ENG. — CONTROL ASSY.

CONTROL ASSY.

<u>NO.</u>	<u>PART NO.</u>	<u>PART NAME</u>	<u>QTY.</u>	<u>REMARKS</u>
2	16551ZE2000	ARM, GOVERNOR	1	
3	16555ZE2000	ROD, GOVERNOR	1	
4	16561ZE2000	SPRING, GOVERNOR	1	
5	16562ZE2000	SPRING, THROTTLE RETURN	1	
6	16570ZE2W00	CONTROL ASSEMBLY .....	1	INCLUDES ITEMS W/*
10*	16571ZE2W00	LEVER, CONTROL	1	
11*	16574ZE1000	SPRING, LEVER	1	
12*	16575ZE2W00	WASHER, CONTROL LEVER	1	
14*	16578ZE1000	SPACER, CONTROL LEVER	1	
15*	16581ZE2W00	BASE, CONTROL	1	
16*	16584883300	SPRING, CONTROL ADJUSTING	1	
19	90013883000	BOLT, FLANGE 6X12(CT200)	2	
20	90015ZE5010	BOLT, GOVERNOR ARM	1	
21*	90114SA0000	NUT, SELF-LOCK 6MM	1	
24*	93500050280A	SCREW, PAN 5X28	1	
27	9405006000	NUT, FLANGE 6MM	1	

# HONDA GX240K1PMT2/GX240U1PMT2 ENG. — CRANKCASE CVR. ASSY.

CRANKCASE COVER ASSY.

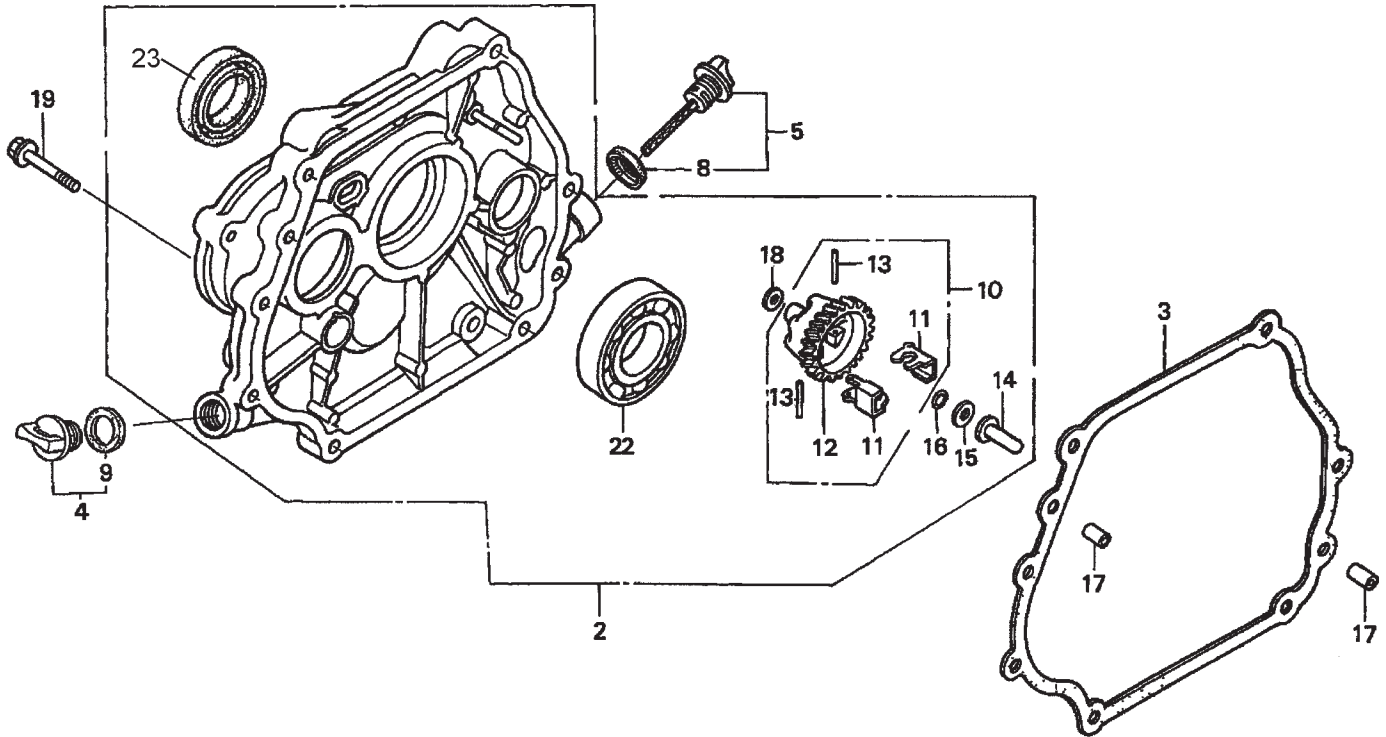

# HONDA GX240K1PMT2/GX240U1PMT2 ENG. — CRANKCASE CVR. ASSY.

## CRANKCASE COVER ASSY.

NO.	PART NO.	PART NAME	QTY.	REMARKS
2✖	11399ZE2600	COVER ASSY., CRANKCASE .....	1	INCLUDES ITEMS W/ * S/N 421135 AND BELOW
2✖	11399ZE2601	COVER ASSY., CRANKCASE .....	1	INCLUDES ITEMS W/ ≥ S/N 421136 AND ABOVE
2◇	11399ZE2602	COVER ASSY., CRANKCASE .....	1	INCLUDES ITEMS W/\$
3	11381ZE2801	GASKET, CASE COVER	1	
4	15600ZG4003	CAP ASSEMBLY, OIL FILLER .....	1	INCLUDES ITEMS W/ %
5	15600735003	CAP ASSEMBLY, OIL FILLER .....	1	INCLUDES ITEMS W/ +
8+	15625ZE1003	GASKET, OIL FILLER CAP	1	
9%	15625ZE1003	GASKET, OIL FILLER CAP	1	
10 *≥\$	16510ZE2000	GOVERNOR ASSEMBLY, STANDARD .....	1	INCLUDES ITEMS W/#
11#*≥\$	16511ZE2000	WEIGHT, GOVERNOR	2	
12#*≥\$	16512ZE2000	HOLDER, GOVERNOR WEIGHT	1	
13#*≥\$	16513ZE2000	PIN, GOVERNOR WEIGHT	2	
14✖*≥	16531ZE2000	SLIDER, GOVERNOR .....	1	S/N 421135 AND BELOW
14✖*≥	16531Z0A000	SLIDER, GOVERNOR .....	1	S/N 421136 AND ABOVE
14◇\$	16531Z0A000	SLIDER, GOVERNOR	1	
16*≥\$	90602ZE1000	CLIP, GOVERNOR HOLDER	1	
17	90701HC4000	PIN, DOWEL 8X12	2	
18*≥\$	9410106800	WASHER, PLAIN 6MM	1	
19	957010803500	BOLT, FLANGE 8X35	7	
22*≥\$	961006206000	BEARING, RADIAL BALL 6206	1	
23*≥\$	91201890003	OIL SEAL, 30X46X8	1	

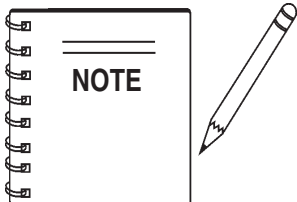

- ✖ GX240K1PMTNH1: Model QP-402H S/N 402H-0417 AND BELOW
- ◇ GX240U1PMTNH1: Model QP-402H S/N 402H-0418 AND ABOVE

# HONDA GX240K1PMT2/GX240U1PMT2 ENG. — CRANKSHAFT ASSY.

CRANKSHAFT ASSY.

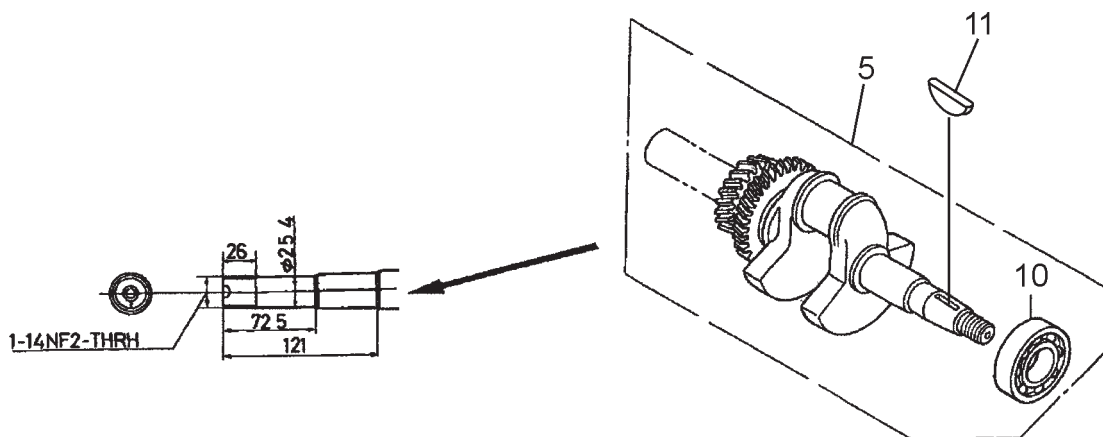

# HONDA GX240K1PMT2/GX240U1PMT2 ENG. — CRANKSHAFT ASSY.

## CRANKSHAFT ASSY.

<u>NO.</u>	<u>PART NO.</u>	<u>PART NAME</u>	<u>QTY.</u>	<u>REMARKS</u>
5✖	13310ZE2651	CRANKSHAFT COMPLETE .....	1 .....	INCLUDES ITEMS W/%
5◇	13310ZE2651	CRANKSHAFT COMPLETE .....	1 .....	INCLUDES ITEMS W/ % ..... S/N 1006124 AND BELOW
5◇	13310ZE2652	CRANKSHAFT, P-TYPE .....	1 .....	INCLUDES ITEMS W/% ..... S/N 1006125 AND ABOVE
10%	961006206000	BEARING, RADIAL BALL 6206	1	
11	90741ZE2000	KEY, SPECIAL WOODRUFF, 25X18	1	

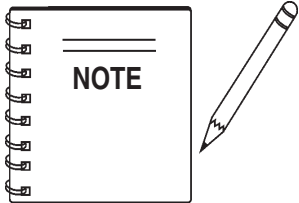

- ✖ GX240K1PMTNH1: Model QP-402H S/N 402H-0417 AND BELOW
- ◇ GX240U1PMTNH1: Model QP-402H S/N 402H-0418 AND ABOVE

# HONDA GX240K1PMT2/GX240U1PMT2 ENG. — CYLINDER BARREL ASSY.

CYLINDER BARREL ASSY.

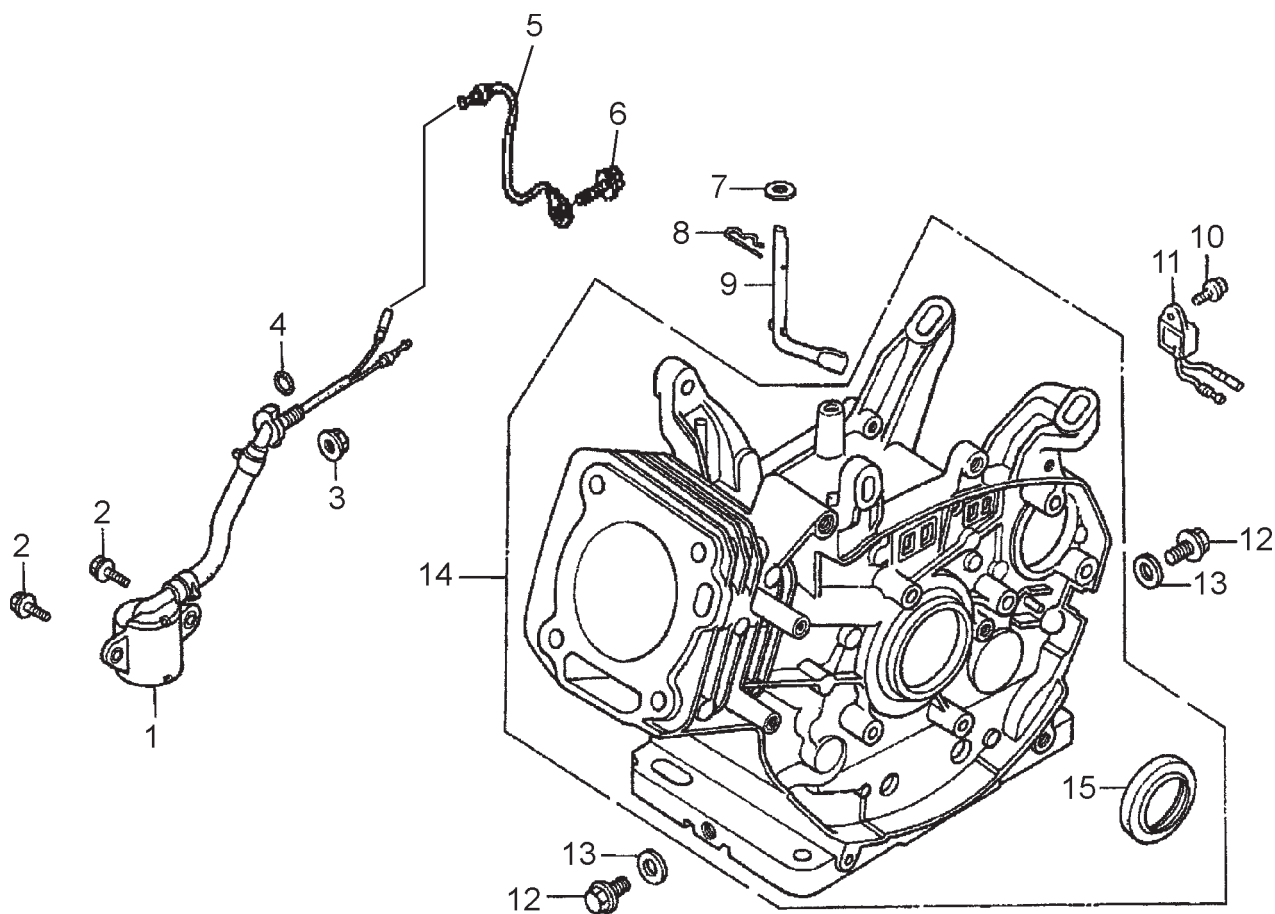

# HONDA GX240K1PMT2/GX240U1PMT2 ENG. — CYLINDER BARREL ASSY.

## CYLINDER BARREL ASSY.

<u>NO.</u>	<u>PART NO.</u>	<u>PART NAME</u>	<u>QTY.</u>	<u>REMARKS</u>
1	15510ZE2043	SWITCH ASSEMBLY, OIL LEVEL	1	
2	957010601200	BOLT, FLANGE 6X12	2	
3	9405010000	NUT, FLANGE 10MM	1	
4	91353671004	O-RING, 14MM (NOK)	1	
5✘	32197ZE2003	SUB HARNESS .....	1	S/N 3566259 AND BELOW
6✘	90013883000	BOLT, FLANGE 6X12 CT200 .....	1	S/N 3566259 AND BELOW
7	90446KE1000	WASHER 8.21X17X0.8	1	
8	9425110000	PIN, LOCK 10MM	1	
9	16541ZE2010	SHAFT, GOVERNOR ARM	1	
10	90013883000	BOLT, FLANGE 6X12 (CT200)	1	
11	34150ZH7003	ALERT UNIT, OIL	1	
12	90131883000	BOLT, DRAIN PLUG 12X15	2	
13	9410912000	WASHER, DRAIN PLUG 12MM	2	
14✘	12000ZE2815	CYLINDER BARREL ASSY., ALERT .....	1	INCLUDES ITEMS W/#
14◇	12000ZE2406	CYLINDER BARREL ASSY., ALERT .....	1	INCULDES ITEMS W/#
15#	91201890003	OIL SEAL 30X46X8		

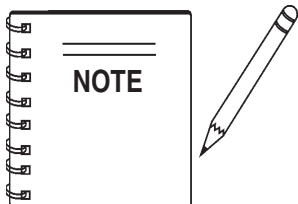

- ✘ GX240K1PMTNH1: Model QP-402H S/N 402H-0417 AND BELOW
- ◇ GX240U1PMTNH1: Model QP-402H S/N 402H-0418 AND ABOVE

# HONDA GX240K1PMT2/GX240U1PMT2 ENG. — CYLINDER HEAD ASSY.

CYLINDER HEAD ASSY.

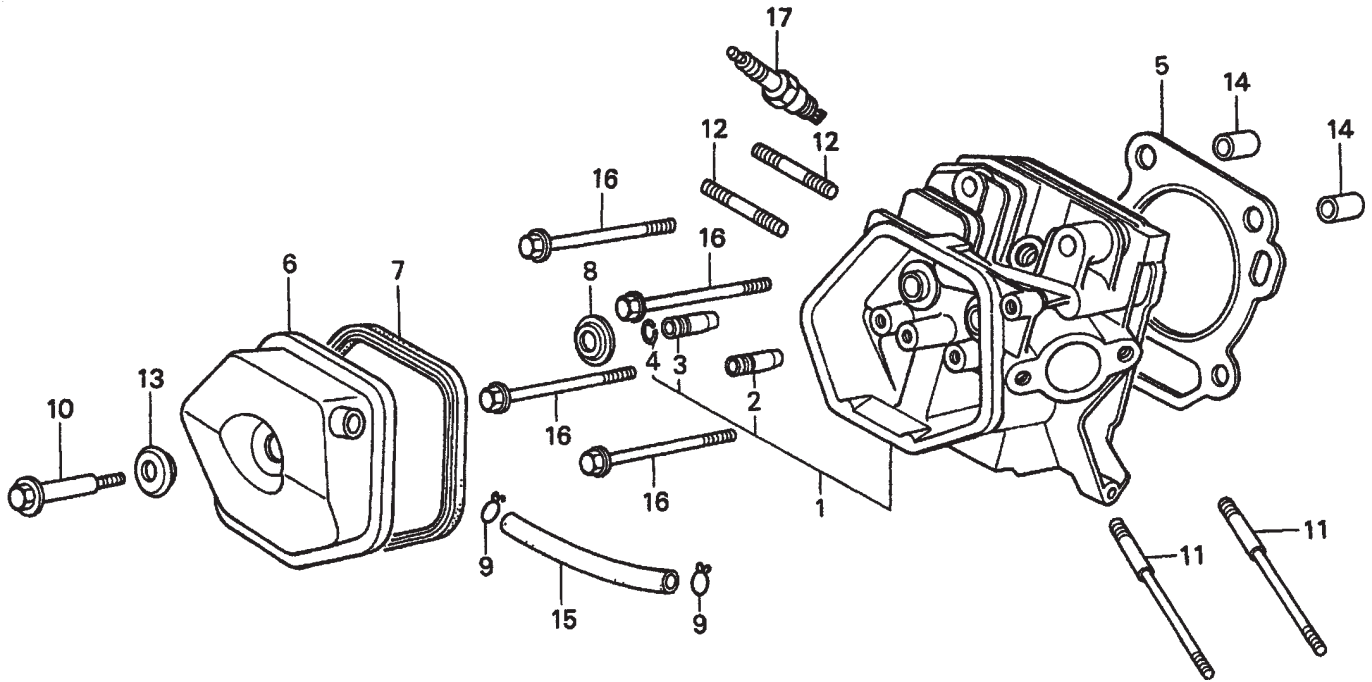

# HONDA GX240K1PMT2/GX240U1PMT2 ENG. — CYLINDER HEAD ASSY.

## CYLINDER HEAD ASSY.

<u>NO.</u>	<u>PART NO.</u>	<u>PART NAME</u>	<u>QTY.</u>	<u>REMARKS</u>
1✖	12200ZH9000	CYLINDER HEAD .....	1 .....	INCLUDES ITEMS W/#
1◇	12200ZH9405	CYLINDER HEAD .....	1 .....	INCLUDES ITEMS W/#
2#	12204ZE2306	GUIDE, VALVE OS (OPTION)	1	
3#	12205ZE2305	GUIDE, EXHAUST VALVE OS (OPTION)	1	
4#	12216ZE2300	CLIP, VALVE GUIDE	1	
5	12251ZE2800	GASKET, CYLINDER HEAD	1	
6	12310ZE2020	COVER, HEAD	1	
7	12391ZE2020	GASKET, CYLINDER HEAD COVER	1	
8✖	14775ZE2010	SEAT, VALVE SPRING	1	
10	90014ZE2000	BOLT, HEAD COVER	1	
11	90042ZE2000	BOLT, STUD 8X123	2	
12	92900080320E	BOLT 2, STUD 8X32	2	
13	90441ZE2010	WASHER, HEAD COVER	1	
14	9430112200	PIN A, DOWEL 12X20	2	
15✖	950051100130M	BULK HOSE, VACUUM (11X1000) (11X100)	1	
15◇	950051110030	TUBE, 11X100 .....	1 .....	REPLACES 950051100130M
16✖	957011008000	BOLT, FLANGE 10X80	4	
16◇	957251008000	BOLT, FLANGE 10X80	4	
17	9807956846	SPARK PLUG BPR6ES (NKG)	1	
17	9807956855	SPARK PLUG (W20EPR-U) (DENSO)	1	

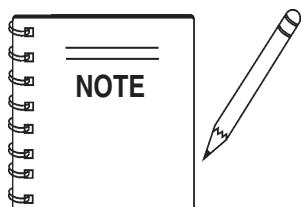

- ✖ GX240K1PMTNH1: Model QP-402H S/N 402H-0417 AND BELOW
- ◇ GX240U1PMTNH1: Model QP-402H S/N 402H-0418 AND ABOVE

# HONDA GX240K1PMT2/GX240U1PMT2 ENG. — FAN COVER ASSY.

FAN COVER ASSY.

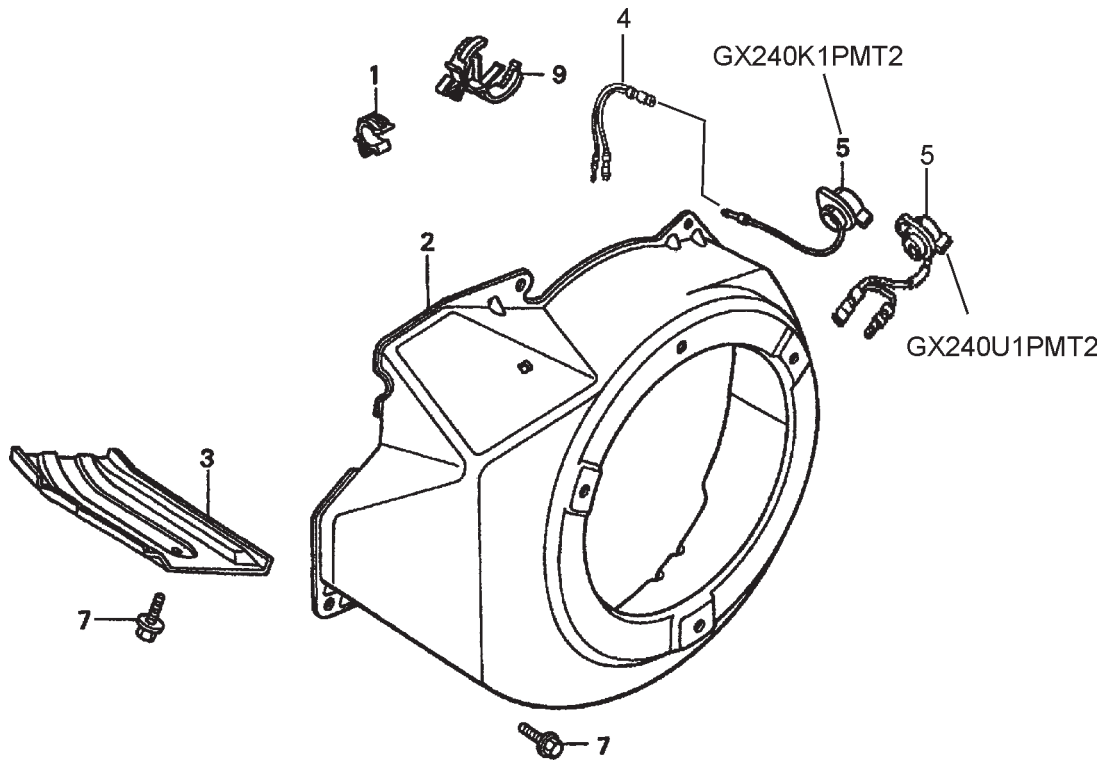

# HONDA GX240K1PMT2/GX240U1PMT2 ENG. — FAN COVER ASSY.

FAN COVER ASSY.

<u>NO.</u>	<u>PART NO.</u>	<u>PART NAME</u>	<u>QTY.</u>	<u>REMARKS</u>
1	16731ZE2003	CLIP, TUBE	1	
2	19610ZE2010ZC	COVER, FAN *NH1* (BLACK)	1	
3	19631ZE2D00	SHROUD	1	
4	32197ZH8003	SUB HARNESS .....	1	S/N 3566259 AND BELOW
5✖	36100ZE1015	SWITCH ASSY., ENGINE STOP .....	1	S/N 3566259 AND BELOW
5✖	36100ZH7003	SWITCH ASSY., ENGINE STOP .....	1	S/N 3566260 AND ABOVE
5◇	36100ZF6P81	SWITCH ASSY., ENGINE STOP	1	
7	90013883000	BOLT, FLANGE 6X12 (CT200)	6	
9✖	90684ZA0601	CLIP, WIRE HARNESS	1	

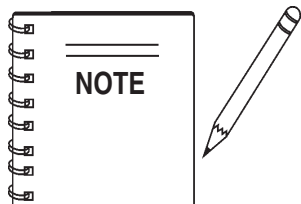

- ✖ GX240K1PMTNH1: Model QP-402H S/N 402H-0417 AND BELOW
- ◇ GX240U1PMTNH1: Model QP-402H S/N 402H-0418 AND ABOVE

# HONDA GX240K1PMT2/GX240U1PMT2 ENG. — FLYWHEEL ASSY.

FLYWHEEL ASSY.

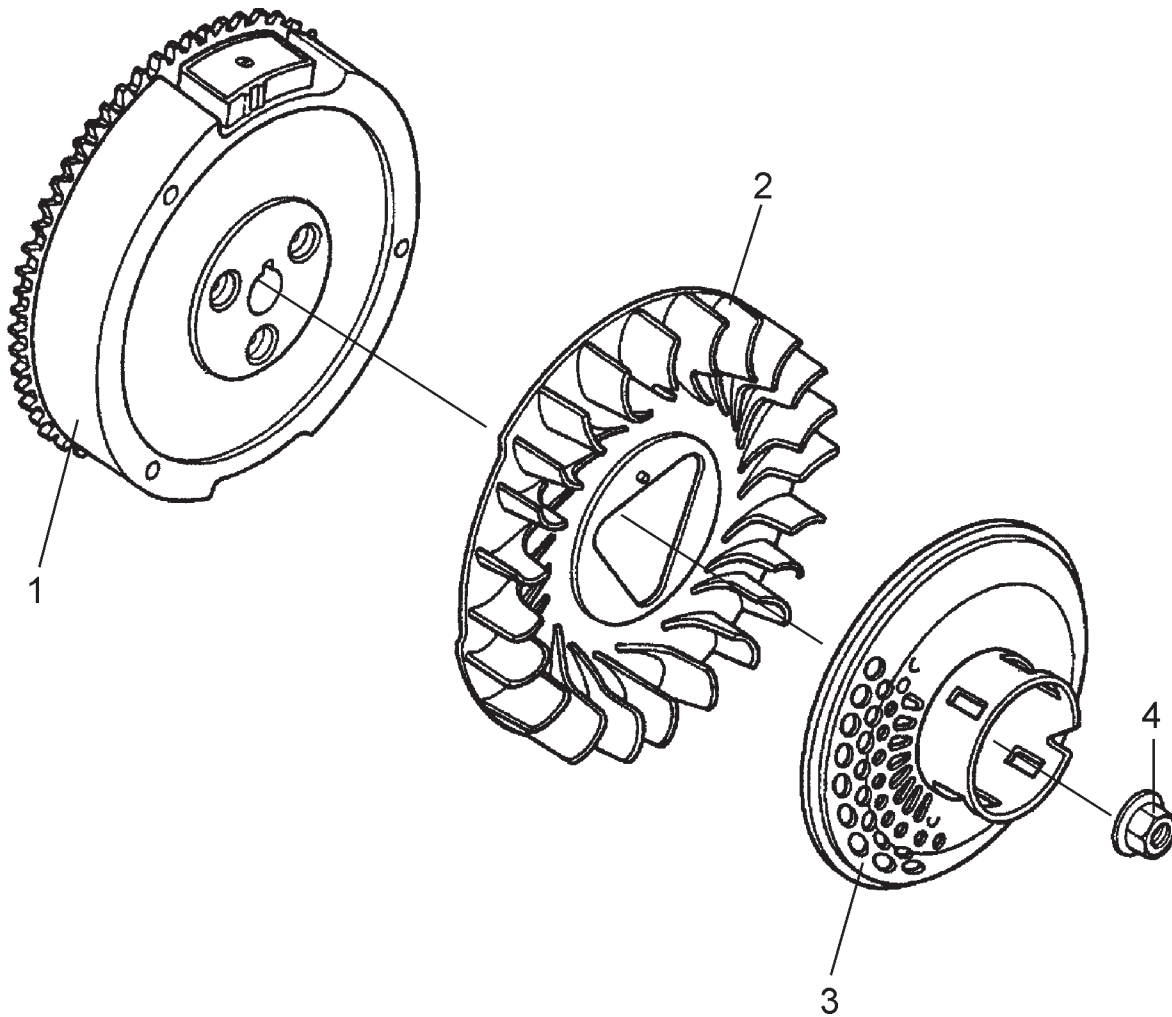

# HONDA GX240K1PMT2/GX240U1PMT2 ENG. — FLYWHEEL ASSY.

FLYWHEEL ASSY.

<u>NO.</u>	<u>PART NO.</u>	<u>PART NAME</u>	<u>QTY.</u>	<u>REMARKS</u>
1	31100ZE2010	FLYWHEEL, COMPLETE	1	
2	19511ZE2000	FAN, COOLING	1	
3	28450ZE2W11	PULLEY, STARTER (SCREEN GRID)	1	
4✖	90201ZE3790	NUT, SPECIAL 16MM .....	1	S/N 3467138 AND BELOW
4✖	90201ZE3V00	NUT, SPECIAL 16MM .....	1	S/N 3467139 AND ABOVE
4◇	90201ZE3V00	NUT, SPECIAL 16MM	1	

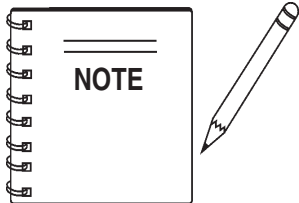

- ✖ GX240K1PMTNH1: Model QP-402H S/N 402H-0417 AND BELOW
- ◇ GX240U1PMTNH1: Model QP-402H S/N 402H-0418 AND ABOVE

# HONDA GX240K1PMT2/GX240U1PMT2 ENG. — FUEL TANK ASSY.

FUEL TANK ASSY.

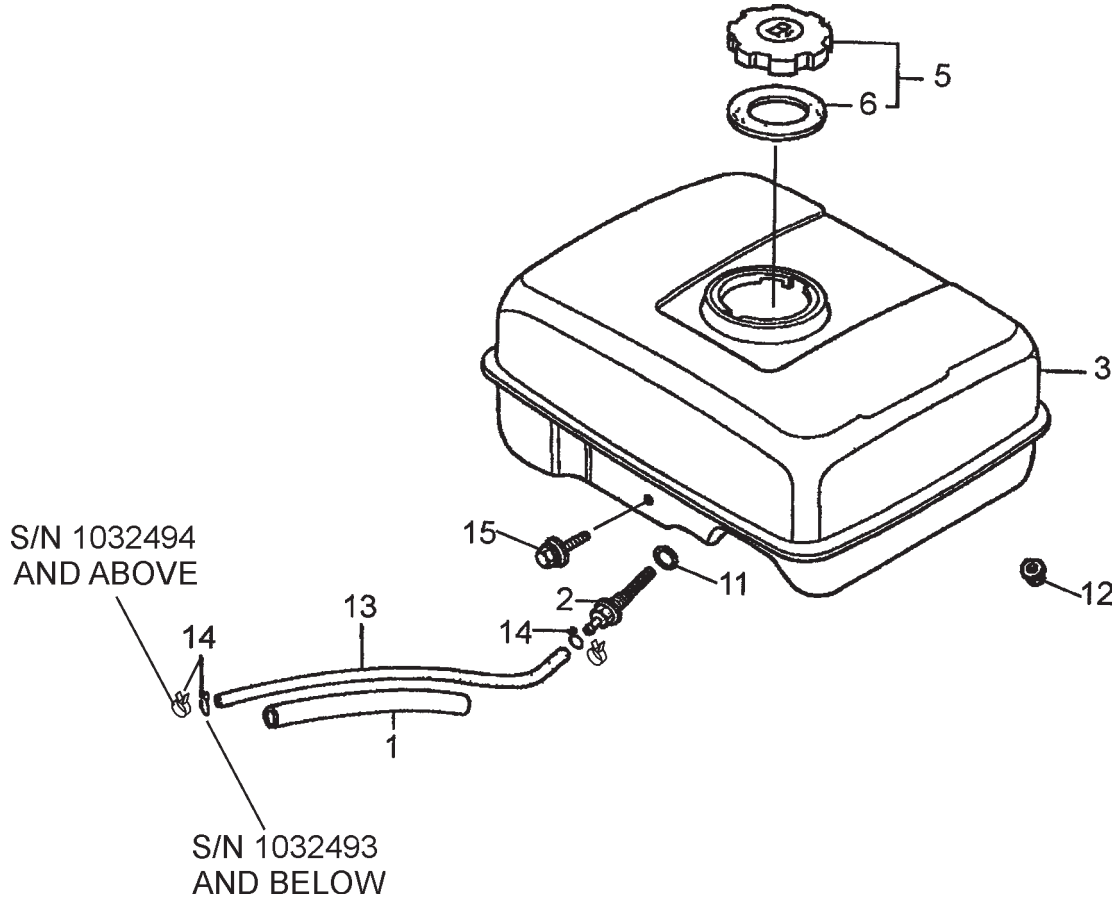

# HONDA GX240K1PMT2/GX240U1PMT2 ENG. — FUEL TANK ASSY.

## FUEL TANK ASSY.

NO.	PART NO.	PART NAME	QTY.	REMARKS
1	16854ZH8000	RUBBER, SUPPORTER 107MM	1	
2	16955ZE1000	JOINT, FUEL TANK	1	
3✖	17510ZE2010ZD	TANK, FUEL *NH1* BLACK	1	
3◇	17510ZE2020ZD	TANK, FUEL *NH1* BLACK .....	1	S/N 1016062 AND BELOW
3◇	17510ZE2800ZA	TANK, FUEL *NH1* BLACK .....	1	S/N 1016063 AND ABOVE
5✖	17620ZH7023	CAP, FUEL FILLER .....	1	INCLUDES ITEMS W/*
5◇	17620Z0T305	CAP, FUEL FILLER (CHROME PLATED) .....	1	INCLUDES ITEMS W/#
6✖*	17631ZH7003	GASKET, FUEL FILLER CAP	1	
6◇#	17631Z0T812	GASKET, FUEL FILLER CAP 39+X62X3	1	
11✖	91353671003	O-RING 13.5X1.5 (ARAI)	1	
11◇	91353671004	O-RING, 14MM (NOK)	1	
12	9405008000	NUT, FLANGE 8MM	2	
13✖	950014500360M	BULK HOSE, FUEL (4.5X3000)(4.5X222)	1	
13◇	950014522240	BULK HOSE, FUEL (4.5X222) .....	1	S/N 1032493 AND BELOW REPLACE 950014500160M
13◇	91424Z5F801	BULK HOSE, FUEL (4.5X222) FKM .....	1	S/N 1032494 AND ABOVE
14✖	9500202080	CLIP, TUBE B8	2	
14◇	9500202080	CLIP, TUBE B8 .....	2	S/N 1032493 AND BELOW
14◇	950024080008	CLAMP, TUBE (D8) .....	2	S/N 1032494 AND ABOVE
15	957010802500	BOLT, FLANGE 8X25	2	

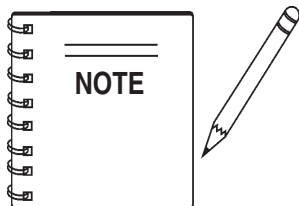

- ✖ GX240K1PMTNH1: Model QP-402H S/N 402H-0417 AND BELOW
- ◇ GX240U1PMTNH1: Model QP-402H S/N 402H-0418 AND ABOVE

# HONDA GX240K1PMT2/GX240U1PMT2 ENG. — IGNITION COIL ASSY.

IGNITION COIL ASSY.

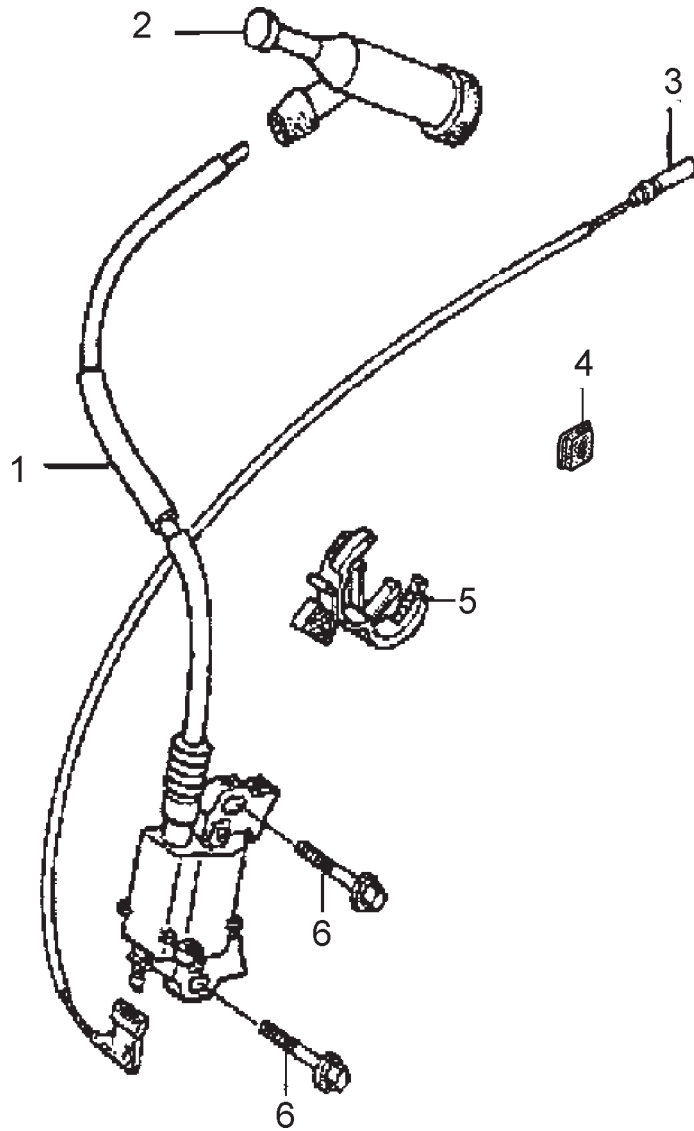

# HONDA GX240K1PMT2/GX240U1PMT2 ENG. — IGNITION COIL ASSY.

## IGNITION COIL ASSY.

<u>NO.</u>	<u>PART NO.</u>	<u>PART NAME</u>	<u>QTY.</u>	<u>REMARKS</u>
1	30500ZE2023	COIL ASSY., IGNITION	1	
2	30700ZE1013	CAP, ASSY., NOISE SUPPRESSOR	1	
3	36101ZE1010	WIRE, STOP SWITCH (370 MM)	1	
4	31512ZE2000	GROMMET, CORD	1	
5◇	90684ZA0601	CLIP, HARNESS	1	
6	90015883000	BOLT, FLANGE (6X28)	2	

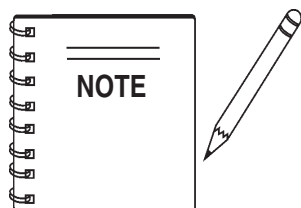

- ✖ GX240K1PMTNH1: Model QP-402H S/N 402H-0417 AND BELOW
- ◇ GX240U1PMTNH1: Model QP-402H S/N 402H-0418 AND ABOVE

# HONDA GX240K1PMT2/GX240U1PMT2 ENG. — MUFFLER ASSY.

MUFFLER ASSY.

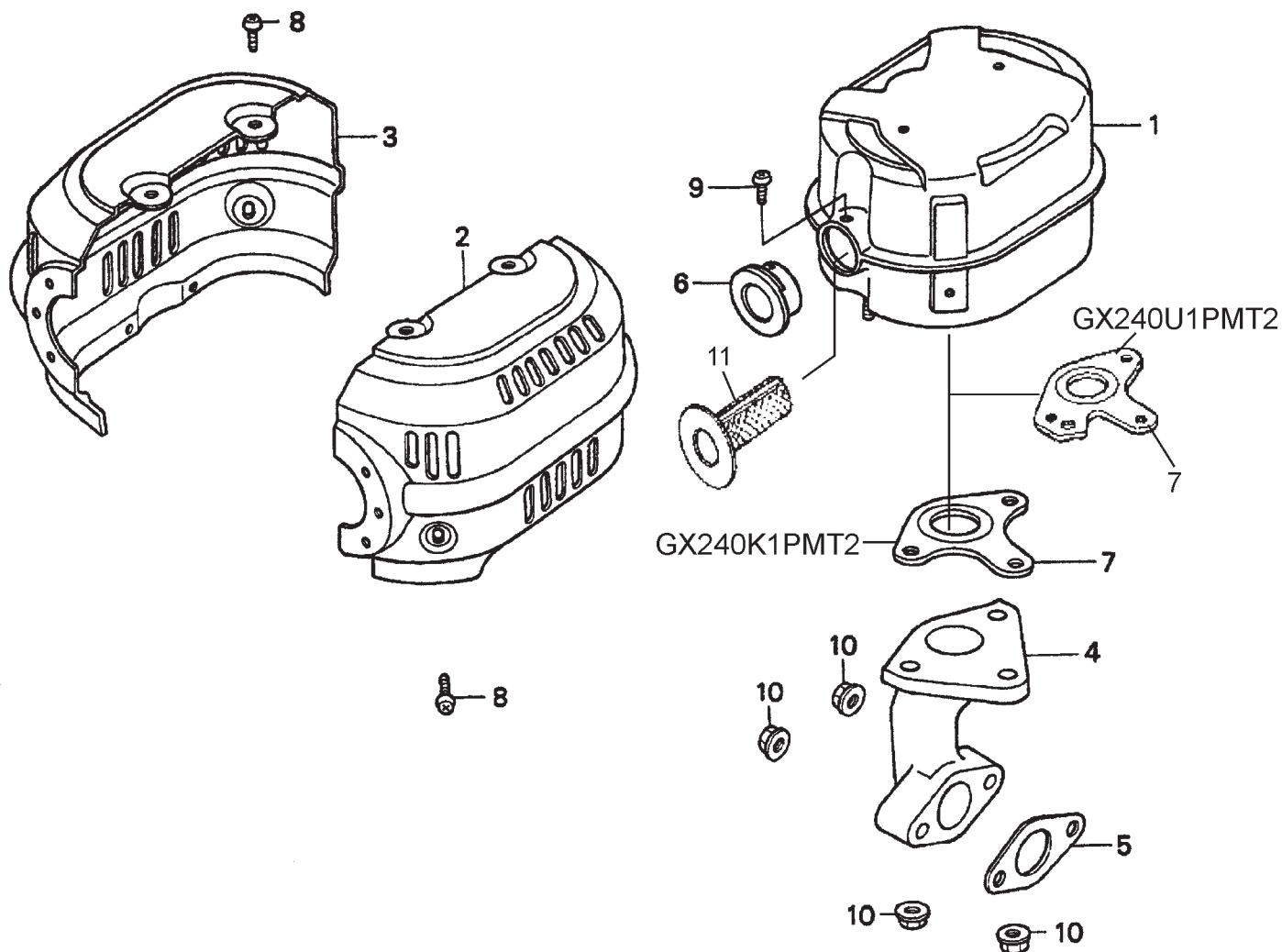

# HONDA GX240K1PMT2/GX240U1PMT2 ENG. — MUFFLER ASSY.

## MUFFLER ASSY.

<u>NO.</u>	<u>PART NO.</u>	<u>PART NAME</u>	<u>QTY.</u>	<u>REMARKS</u>
1	18310ZE2822	MUFFLER ( SILENT)	1	
2	18320ZE2P50	PROTECTOR, RIGHT MUFFLER (SILENT)	1	
3	18325ZE2P50	PROTECTOR, LEFT MUFFLER (SILENT)	1	
4	18330ZE2000	PIPE, EXHAUST	1	
5	18333ZE3800	GASKET, EXHAUST PIPE	1	
6	18336ZE2000	FLANGE, BAFFLE	1	
7✖	18381ZE2800	GASKET, MUFFLER	1	
7◇	18381ZE2W10	GASKET, MUFFLER ARRESTER, (OPTION)	1	
8	90050ZE3H00	SCREW, TAPPING 5X8	6	
9	90055ZE1000	SCREW, TAPPING 4X6	1	
10	9405008000	NUT, FLANGE 8MM	5	
11◇	18355ZE2010	ARRESTER, SPARK, (OPTION)	1	

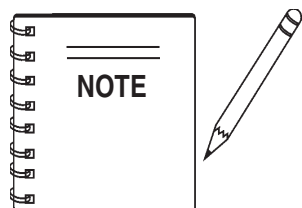

- ✖ GX240K1PMTNH1: Model QP-402H S/N 402H-0417 AND BELOW
- ◇ GX240U1PMTNH1: Model QP-402H S/N 402H-0418 AND ABOVE

# HONDA GX240K1PMT2/GX240U1PMT2 ENG. — PISTON ASSY.

PISTON ASSY.

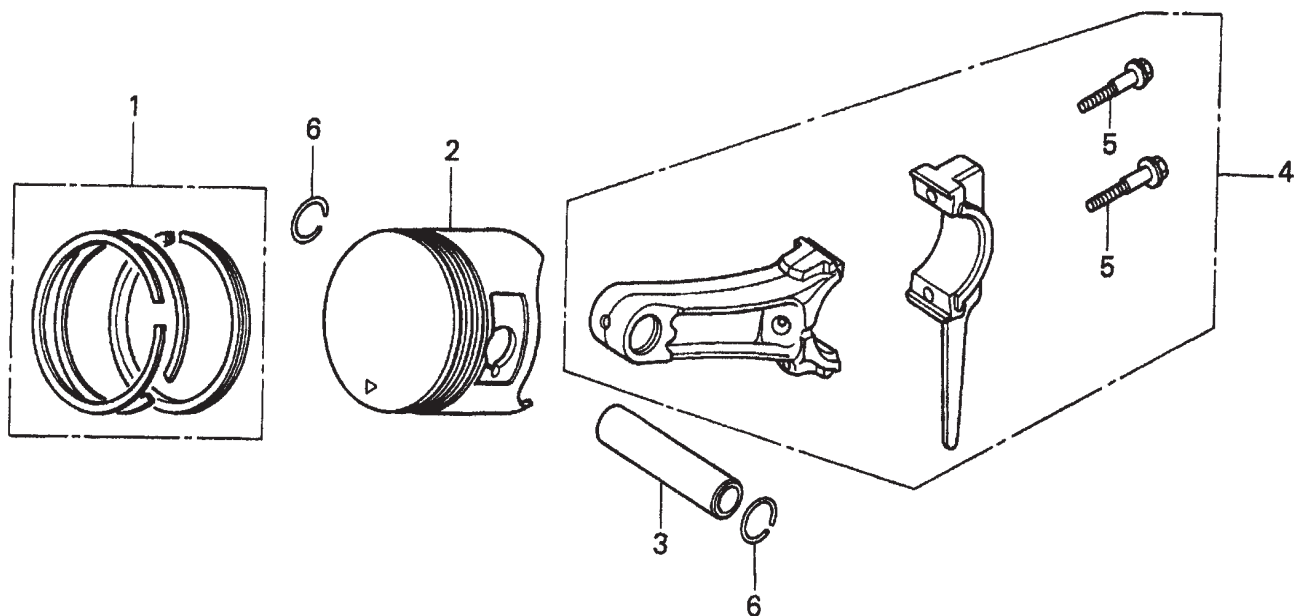

# HONDA GX240K1PMT2/GX240U1PMT2 ENG. — PISTON ASSY.

## PISTON ASSY.

NO.	PART NO.	PART NAME	QTY.	REMARKS
1✖	13010ZE2014	RING SET, PISTON (STD.) .....	1 .....	S/N 4081304 AND BELOW
1✖	13010ZE2921	RING SET, PISTON (STD.) .....	1 .....	S/N 4081305 AND ABOVE
1◇	13010ZE2921	RING SET, PISTON (STD.) .....	1 .....	
1✖	13011ZE2014	RING SET, PISTON (0.25) .....	1 .....	S/N 4081304 AND BELOW
1✖	13011ZE2921	RING SET, PISTON (0.25) .....	1 .....	S/N 4081305 AND ABOVE
1◇	13011ZE2921	RING SET, PISTON (0.25) .....	1 .....	
1✖	13012ZE2014	RING SET, PISTON (0.50) .....	1 .....	S/N 4081304 AND BELOW
1✖	13012ZE2921	RING SET, PISTON (0.50) .....	1 .....	S/N 4081305 AND ABOVE
1◇	13012ZE2921	RING SET, PISTON (0.50) .....	1 .....	
1✖	13013ZE2014	RING SET, PISTON (0.75) .....	1 .....	S/N 4081304 AND BELOW
1✖	13013ZE2921	RING SET, PISTON (0.75) .....	1 .....	S/N 4081304 AND BELOW
1◇	13013ZE2921	RING SET, PISTON (0.75) .....	1 .....	
2	13101ZE2W00	PISTON (STD.) .....	1 .....	
2	13102ZE2W00	PISTON (OS 0.25) .....	1 .....	
2	13103ZE2W00	PISTON (OS 0.50) .....	1 .....	
2	13104ZE2W00	PISTON (0.75) .....	1 .....	
3	13111ZE2000	PIN, PISTON .....	1 .....	
4✖	13200ZE2000	ROD ASSY., CONNECTING (STANDARD) .....	1 .....	INCLUDES ITEMS W/#
4◇	13200ZE2010	ROD ASSY., CONNECTING (STANDARD) .....	1 .....	INCLUDES ITEMS W/#
4	13200ZE2305	ROD ASSY., CONNECTING (0.25) .....	1 .....	
5#	90001ZE8000	BOLT, CONNECTING ROD .....	2 .....	
6	90551ZE1000	CLIP, PISTON PIN 18 MM .....	2 .....	

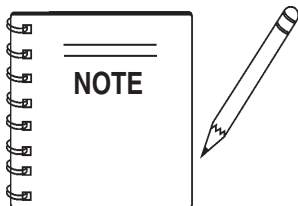

- ✖ GX240K1PMTNH1: Model QP-402H S/N 402H-0417 AND BELOW
- ◇ GX240U1PMTNH1: Model QP-402H S/N 402H-0418 AND ABOVE

# HONDA GX240K1PMT2/GX240U1PMT2 ENG. — RECOIL STARTER ASSY.

RECOIL STARTER ASSY.

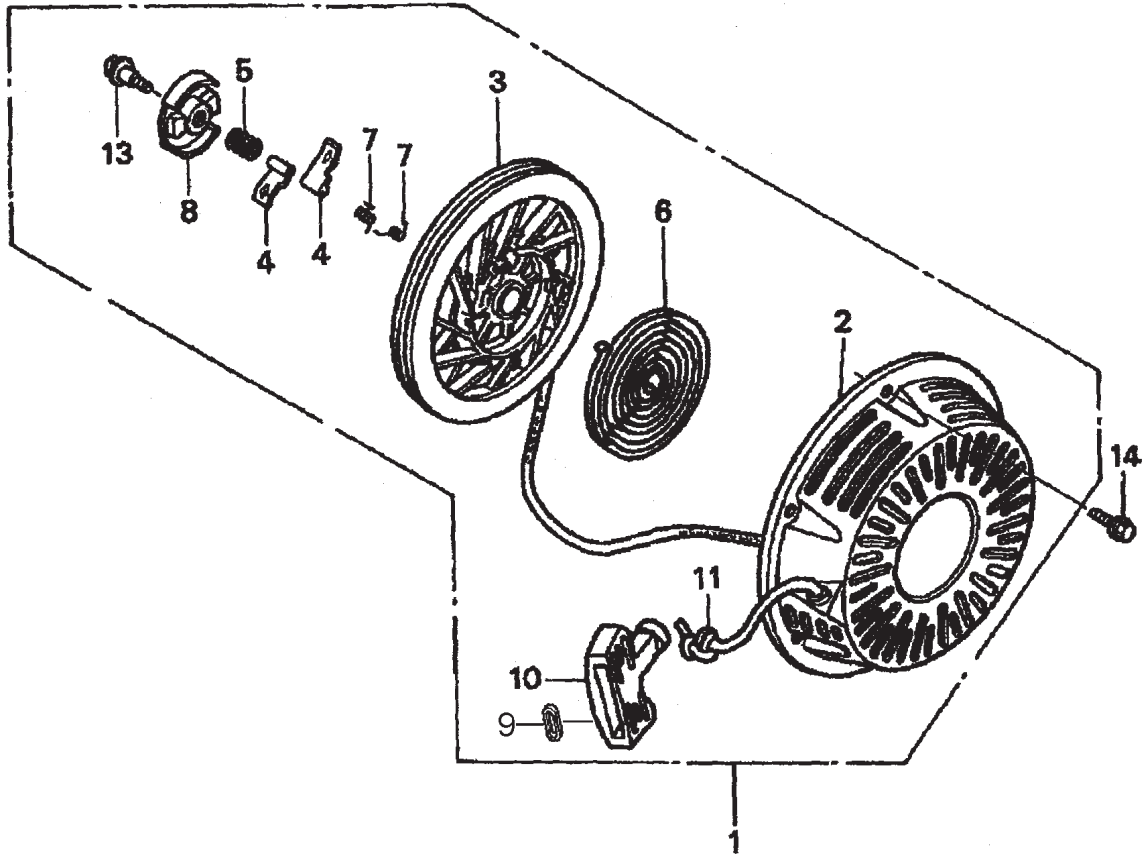

# HONDA GX240K1PMT2/GX240U1PMT2 ENG. — RECOIL STARTER ASSY.

## RECOIL STARTER ASSY.

NO.	PART NO.	PART NAME	QTY.	REMARKS
1✖	28400ZE2W01ZB	STARTER ASSY., RECOIL *NH1* BLACK .....	1 .....	INCLUDES ITEMS W/#
1◇	28400ZE2W01ZB	STARTER ASSY., RECOIL *NH1* BLACK .....	1 .....	INCLUDES ITEMS W/%
2#%	28410ZE2W01ZB	CASE, RECOIL STARTER *NH1* BLACK	1	
3#%	28421ZE2W01	PULLEY, RECOIL STARTER	1	
4#%	28422ZE2W01	RACHET, STARTER	2	
5#%	28441ZE2W01	SPRING, FRICTION	1	
6#%	28442ZE2W01	SPRING, STARTER RETURN	1	
7#%	28443ZE2W01	SPRING, RATCHET	2	
8#%	28444ZE2W01	RETAINER, SPRING	1	
9✖#	28469ZE2W01	GRIP. REINFORCEMENT .....	1 .....	S/N 3793540 AND BELOW
10#%	28461ZE2W02	GRIP, STARTER	1	
11✖#	28462ZE2W01	ROPE, RECOIL STARTER .....	1 .....	S/N 3793540 AND BELOW
11✖#	28462ZE2W11	ROPE, RECOIL STARTER .....	1 .....	S/N 3793541 AND ABOVE
11◇%	28462ZE2W11	ROPE, RECOIL STARTER	1	
13#%	90004ZE2W01	SCREW, CENTER	1	
14	90008ZE2003	BOLT, FLANGE 6X10	3	

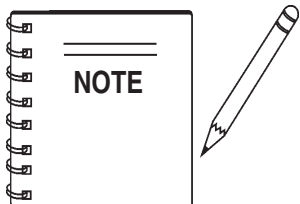

- ✖ GX240K1PMTNH1: Model QP-402H S/N 402H-0417 AND BELOW
- ◇ GX240U1PMTNH1: Model QP-402H S/N 402H-0418 AND ABOVE

# HONDA GX240K1PMT2/GX240U1PMT2 ENG. — GASKET KIT ASSY.

GASKET KIT ASSY.

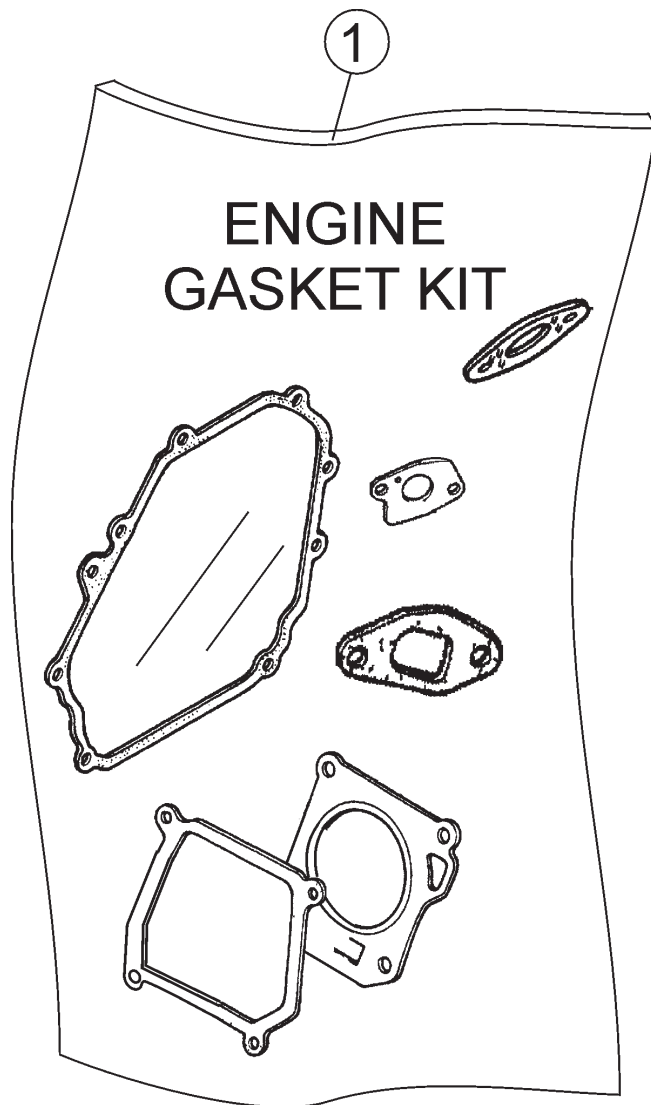

# HONDA GX240K1PMT2/GX240U1PMT2 ENG. — GASKET KIT ASSY.

GASKET KIT ASSY.

<u>NO.</u>	<u>PART NO.</u>	<u>PART NAME</u>	<u>QTY.</u>	<u>REMARKS</u>
1✖	061A1ZE2040	GASKET KIT, ENGINE .....	1 .....	S/N 4045100 AND ABOVE

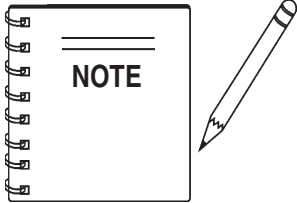

- ✖ GX240K1PMTNH1: Model QP-402H S/N 402H-0417 AND BELOW
- ◇ GX240U1PMTNH1: Model QP-402H S/N 402H-0418 AND ABOVE

# HONDA GX240K1PMT2/GX240U1PMT2 ENG. — LABELS ASSY.

LABELS ASSY.

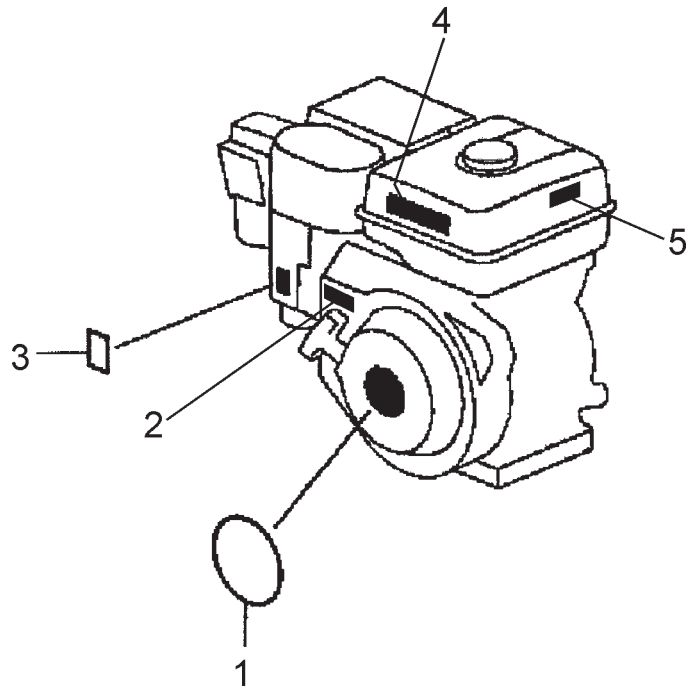

# HONDA GX240K1PMT2/GX240U1PMT2 ENG. — LABELS ASSY.

## LABELS ASSY.

<u>NO.</u>	<u>PART NO.</u>	<u>PART NAME</u>	<u>QTY.</u>	<u>REMARKS</u>
1✘	87521ZE2W01	EMBLEM (GX240 HONDA 8.0) .....	1 .....	S/N 4192760 AND BELOW
1✘	87521ZE2W02	EMBLEM (GX240 HONDA 8.0) .....	1 .....	S/N 4192761 AND ABOVE
1◇	87521ZE2W03	EMBLEM (GX240 HONDA 8.0) .....	1 .....	S/N 4192761 AND ABOVE
2◇	87532ZH7000	MARK, THROTTLE INDICATION		
3✘	87528ZE2810	MARK, CHOKE (ORANGE)	1	
3◇	87528ZH7000	MARK, CHOKE (GRAY)	1	
4✘	87522ZH9010	LABEL, CAUTION	1	
4◇	87516ZH7000	MARK, OPERATOR CAUTION	1	
5✘	87532ZH8810	MARK, OIL ALERT (E)	1	

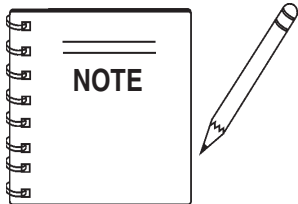

- ✘ GX240K1PMTNH1: Model QP-402H S/N 402H-0417 AND BELOW
- ◇ GX240U1PMTNH1: Model QP-402H S/N 402H-0418 AND ABOVE

# TERMS AND CONDITIONS OF SALE — PARTS

## PAYMENT TERMS

Terms of payment for parts are net 30 days.

## FREIGHT POLICY

All parts orders will be shipped collect or prepaid with the charges added to the invoice. All shipments are F.O.B. point of origin. Multiquip's responsibility ceases when a signed manifest has been obtained from the carrier, and any claim for shortage or damage must be settled between the consignee and the carrier.

## MINIMUM ORDER

The minimum charge for orders from Multiquip is \$15.00 net. Customers will be asked for instructions regarding handling of orders not meeting this requirement.

## RETURNED GOODS POLICY

Return shipments will be accepted and credit will be allowed, subject to the following provisions:

1. A Returned Material Authorization must be approved by Multiquip prior to shipment.
2. To obtain a Return Material Authorization, a list must be provided to Multiquip Parts Sales that defines item numbers, quantities, and descriptions of the items to be returned.
  - a. The parts numbers and descriptions must match the current parts price list.
  - b. The list must be typed or computer generated.
  - c. The list must state the reason(s) for the return.
  - d. The list must reference the sales order(s) or invoice(s) under which the items were originally purchased.
  - e. The list must include the name and phone number of the person requesting the RMA.
3. A copy of the Return Material Authorization must accompany the return shipment.
4. Freight is at the sender's expense. All parts must be returned freight prepaid to Multiquip's designated receiving point.

5. Parts must be in new and resalable condition, in the original Multiquip package (if any), and with Multiquip part numbers clearly marked.
6. The following items are not returnable:
  - a. Obsolete parts. (If an item is in the price book and shows as being replaced by another item, it is obsolete.)
  - b. Any parts with a limited shelf life (such as gaskets, seals, "O" rings, and other rubber parts) that were purchased more than six months prior to the return date.
  - c. Any line item with an extended dealer net price of less than \$5.00.
  - d. Special order items.
  - e. Electrical components.
  - f. Paint, chemicals, and lubricants.
  - g. Decals and paper products.
  - h. Items purchased in kits.
7. The sender will be notified of any material received that is not acceptable.
8. Such material will be held for five working days from notification, pending instructions. If a reply is not received within five days, the material will be returned to the sender at his expense.
9. Credit on returned parts will be issued at dealer net price at time of the original purchase, less a 15% restocking charge.
10. In cases where an item is accepted, for which the original purchase document can not be determined, the price will be based on the list price that was effective twelve months prior to the RMA date.
11. Credit issued will be applied to future purchases only.

## PRICING AND REBATES

Prices are subject to change without prior notice. Price changes are effective on a specific date and all orders received on or after that date will be billed at the revised price. Rebates for price declines and added charges for price increases will not be made for stock on hand at the time of any price change.

Multiquip reserves the right to quote and sell direct to Government agencies, and to Original Equipment Manufacturer accounts who use our products as integral parts of their own products.

## SPECIAL EXPEDITING SERVICE

A \$35.00 surcharge will be added to the invoice for special handling including bus shipments, insured parcel post or in cases where Multiquip must personally deliver the parts to the carrier.

## LIMITATIONS OF SELLER'S LIABILITY

Multiquip shall not be liable hereunder for damages in excess of the purchase price of the item with respect to which damages are claimed, and in no event shall Multiquip be liable for loss of profit or good will or for any other special, consequential or incidental damages.

## LIMITATION OF WARRANTIES

No warranties, express or implied, are made in connection with the sale of parts or trade accessories nor as to any engine not manufactured by Multiquip. Such warranties made in connection with the sale of new, complete units are made exclusively by a statement of warranty packaged with such units, and Multiquip neither assumes nor authorizes any person to assume for it any other obligation or liability whatever in connection with the sale of its products. Apart from such written statement of warranty, there are no warranties, express, implied or statutory, which extend beyond the description of the products on the face hereof.

Effective: February 22, 2006



# OPERATION AND PARTS MANUAL

## HERE'S HOW TO GET HELP

PLEASE HAVE THE MODEL AND SERIAL  
NUMBER *ON-HAND* WHEN CALLING

### UNITED STATES

#### ***Multiquip Corporate Office***

18910 Wilmington Ave. Tel. (800) 421-1244  
Carson, CA 90746 Fax (800) 537-3927  
Contact: mq@multiquip.com

#### ***Mayco Parts***

800-306-2926 Fax: 800-672-7877  
310-537-3700 Fax: 310-637-3284

#### ***Service Department***

800-421-1244 Fax: 310-537-4259  
310-537-3700

#### ***MQ Parts Department***

800-427-1244 Fax: 800-672-7877  
310-537-3700 Fax: 310-637-3284

#### ***Warranty Department***

800-421-1244, Ext. 279 Fax: 310-537-1173  
310-537-3700, Ext. 279

#### ***Technical Assistance***

800-478-1244 Fax: 310-631-5032

### MEXICO

#### ***MQ Cipsa***

Carr. Fed. Mexico-Puebla KM 126.5 Tel: (52) 222-225-9900  
Momoxpan, Cholula, Puebla 72760 Mexico Fax: (52) 222-285-0420  
Contact: pmastretta@cipsa.com.mx

### CANADA

#### ***Multiquip***

4110 Industriel Boul. Tel: (450) 625-2244  
Laval, Quebec, Canada H7L 6V3 Fax: (450) 625-8664  
Contact: jmartin@multiquip.com

### UNITED KINGDOM

#### ***Multiquip (UK) Limited Head Office***

Hanover Mill, Fitzroy Street, Tel: 0161 339 2223  
Ashton-under-Lyne, Fax: 0161 339 3226  
Lancashire OL7 0TL  
Contact: sales@multiquip.co.uk

### BRAZIL

#### ***Multiquip***

Av. Evandro Lins e Silva, 840 - grupo 505 Tel: 011-55-21-3433-9055  
Barra de Tijuca - Rio de Janeiro Fax: 011-55-21-3433-9055  
Contact: cnavarro@multiquip.com.br, srentes@multiquip.com.br

© COPYRIGHT 2008, MULTIQUIP INC.

Multiquip Inc, the MQ logo are registered trademarks of Multiquip Inc. and may not be used, reproduced, or altered without written permission. All other trademarks are the property of their respective owners and used with permission.

This manual MUST accompany the equipment at all times. This manual is considered a permanent part of the equipment and should remain with the unit if resold.

The information and specifications included in this publication were in effect at the time of approval for printing. Illustrations, descriptions, references and technical data contained in this manual are for guidance only and may not be considered as binding. Multiquip Inc. reserves the right to discontinue or change specifications, design or the information published in this publication at any time without notice and without incurring any obligations.

Your Local Dealer is:

