

OPERATION AND PARTS MANUAL



MODEL QP2TH TRASH PUMP (HONDA GX160K1QX2/GX160U1QX2 GASOLINE ENGINE)

Revision #4 (11/04/11)

To find the latest revision of this
publication, visit our website at:
www.multiquip.com



THIS MANUAL MUST ACCOMPANY THE EQUIPMENT AT ALL TIMES.

**CALIFORNIA — Proposition 65 Warning**

Engine exhaust and some of its constituents are known to the State of California to cause cancer, birth defects and other reproductive harm.

**Multiquip QP2TH
Gasoline Powered Trash Pump**

Proposition 65 Warning 2
 Table of Contents 4
 Parts Ordering Procedures 5
 Safety Information 6-10
 Pump Specifications/Dimensions 12
 Engine Specifications 13
 General Information 14
 Pump Components 15
 Refueling 16
 Basic Engine 17
 Pre-Inspection (Engine) 18
 Pre-Set-up (Pump) 19
 Initial Start-up (Engine) 20-21
 Maintenance (Pump) 22-23
 Maintenance (Engine) 24-25
 Preparation for Long-Term Storage 26
 Troubleshooting (Pump) 28
 Troubleshooting (Pump/Engine) 29
 Explanation Of Code In Remarks Column 30
 Suggested Spare Parts 31

**Honda GX160K1QX2/
GX160U1QX2 Engine**

Air Cleaner (Dual) Assembly 36-37
 Camshaft Assembly 38-39
 Carburetor Assembly 40-41
 Control Assembly 42-43
 Crankcase Cover Assembly 44-45
 Crankshaft/Balancer Assembly 46-47
 Cylinder Barrel Assembly 48-49
 Cylinder Head Assembly 50-51
 Fan Cover Assembly 52-53
 Flywheel Assembly 54-55
 Fuel Tank Assembly 56-57
 Ignition Coil Assembly 58-59
 Muffler Assembly 60-61
 Piston Assembly 62-63
 Recoil Starter Assembly 64-65
 Gasket Kit Assembly 66-67
 Labels Assembly 68-69
 Terms and Condition Of Sale — Parts 70

Component Drawing

Pump Assembly 32-35

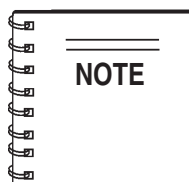

*Specification and part number
are subject to change without
notice.*

PARTS ORDERING PROCEDURES

Ordering parts has never been easier! Choose from three easy options:

Effective:
January 1st, 2006



Order via Internet (Dealers Only):

Order parts on-line using Multiquip's SmartEquip website!

- View Parts Diagrams
- Order Parts
- Print Specification Information



If you have an MQ Account, to obtain a Username and Password, E-mail us at: parts@multiquip.com.

To obtain an MQ Account, contact your District Sales Manager for more information.

Goto www.multiquip.com and click on **Order Parts** to log in and save!

Use the **internet** and qualify for a **5% Discount** on *Standard orders* for all orders which include complete part numbers.*

Note: Discounts Are Subject To Change



Order via Fax (Dealers Only):

All customers are welcome to order parts via Fax.

Domestic (US) Customers dial:
1-800-6-PARTS-7 (800-672-7877)

Fax your order in and qualify for a **2% Discount** on *Standard orders* for all orders which include complete part numbers.*

Note: Discounts Are Subject To Change



Order via Phone: Domestic (US) Dealers Call:
1-800-427-1244

Non-Dealer Customers:

Contact your local Multiquip Dealer for parts or call 800-427-1244 for help in locating a dealer near you.



International Customers should contact their local Multiquip Representatives for Parts Ordering information.

When ordering parts, please supply:

- | | |
|---|--|
| <input type="checkbox"/> Dealer Account Number | <input type="checkbox"/> Specify Preferred Method of Shipment: |
| <input type="checkbox"/> Dealer Name and Address | <input checked="" type="checkbox"/> UPS/Fed Ex <input checked="" type="checkbox"/> DHL |
| <input type="checkbox"/> Shipping Address (if different than billing address) | <input type="checkbox"/> Priority One <input checked="" type="checkbox"/> Truck |
| <input type="checkbox"/> Return Fax Number | <input type="checkbox"/> Ground |
| <input type="checkbox"/> Applicable Model Number | <input type="checkbox"/> Next Day |
| <input type="checkbox"/> Quantity, Part Number and Description of Each Part | <input type="checkbox"/> Second/Third Day |

NOTICE

All orders are treated as *Standard Orders* and will ship the same day if received prior to 3PM PST.

WE ACCEPT ALL MAJOR CREDIT CARDS!



www.multiquip.com



SAFETY INFORMATION

Do not operate or service the equipment before reading the entire manual. Safety precautions should be followed at all times when operating this equipment. Failure to read and understand the safety messages and operating instructions could result in injury to yourself and others.



SAFETY MESSAGES

The four safety messages shown below will inform you about potential hazards that could injure you or others. The safety messages specifically address the level of exposure to the operator and are preceded by one of four words: **DANGER**, **WARNING**, **CAUTION** or **NOTICE**.

SAFETY SYMBOLS

DANGER

Indicates a hazardous situation which, if not avoided, **WILL** result in **DEATH** or **SERIOUS INJURY**.

WARNING

Indicates a hazardous situation which, if not avoided, **COULD** result in **DEATH** or **SERIOUS INJURY**.







CAUTION

Indicates a hazardous situation which, if not avoided, **COULD** result in **MINOR** or **MODERATE INJURY**.

NOTICE

Addresses practices not related to personal injury.

Potential hazards associated with the operation of this equipment will be referenced with hazard symbols which may appear throughout this manual in conjunction with safety messages.

Symbol	Safety Hazard
	Lethal exhaust gas hazards
	Explosion hazards
	Burn hazards
	Pressurized fluid hazards
	Battery acid hazards
	Eye safety hazards

GENERAL SAFETY

CAUTION

- **NEVER** operate this equipment without proper protective clothing, shatterproof glasses, respiratory protection, hearing protection, steel-toed boots and other protective devices required by the job or city and state regulations.



- **NEVER** operate this equipment when not feeling well due to fatigue, illness or when under medication.



- **NEVER** operate this equipment under the influence of drugs or alcohol.



NOTICE

- This equipment should only be operated by trained and qualified personnel 18 years of age and older.
- Whenever necessary, replace nameplate, operation and safety decals when they become difficult read.
- Manufacturer does not assume responsibility for any accident due to equipment modifications. Unauthorized equipment modification will void all warranties.
- **NEVER** use accessories or attachments that are not recommended by Multiquip for this equipment. Damage to the equipment and/or injury to user may result.
- **ALWAYS** know the location of the nearest **fire extinguisher**.
- **ALWAYS** know the location of the nearest **first aid kit**.
- **ALWAYS** know the location of the nearest phone or **keep a phone on the job site**. Also, know the phone numbers of the nearest **ambulance, doctor** and **fire department**. This information will be invaluable in the case of an emergency.



PUMP SAFETY

DANGER

- **NEVER** pump volatile, explosive, flammable or low flash point fluids. These fluids could ignite or explode.
- The engine fuel exhaust gases contain poisonous carbon monoxide. This gas is colorless and odorless, and can cause death if inhaled.
- The engine of this equipment requires an adequate free flow of cooling air. **NEVER** operate this equipment in any enclosed or narrow area where free flow of the air is restricted. If the air flow is restricted it will cause injury to people and property and serious damage to the equipment or engine.



- **NEVER** operate the equipment in an explosive atmosphere or near combustible materials. An explosion or fire could result causing severe **bodily harm or even death**.



WARNING

- **NEVER** pump corrosive chemicals or water containing toxic substances. These fluids could create serious health and environmental hazards. Contact local authorities for assistance.
- **NEVER** open the priming plug when pump is hot. Hot water inside could be pressurized much like the radiator of an automobile. Allow pump to cool to the touch before loosening plug. The possibility exists of scalding, resulting in severe bodily harm.
- **NEVER** disconnect any **emergency or safety devices**. These devices are intended for operator safety. Disconnection of these devices can cause severe injury, bodily harm or even death. Disconnection of any of these devices will void all warranties.



SAFETY INFORMATION

CAUTION

- **NEVER** lubricate components or attempt service on a running machine.
- **NEVER** block or restrict flow from discharge hose. Remove kinks from discharge line before starting pump. Operation with a blocked discharge line can cause water inside pump to overheat.

NOTICE

- **ALWAYS** fill the pump casing with water before starting the engine. Failure to maintain water inside the pump housing will cause severe damage to the pump and mechanical seal.
- In winter drain water from pump housing to prevent freezing.
- **NEVER** start the pump with the clean-out cover removed. The rotating impeller inside the pump can cut or sever objects caught in it. Before starting the pump, check that the clean-out cover is securely fastened.
- **ALWAYS** keep the machine in proper running condition.
- **ALWAYS** ensure pump is on level ground before use.
- Fix damage to machine and replace any broken parts immediately.
- **ALWAYS** store equipment properly when it is not being used. Equipment should be stored in a clean, dry location out of the reach of children and unauthorized personnel.

ENGINE SAFETY

WARNING

- **NEVER** operate the engine with heat shields or guards removed.
- **DO NOT** remove the engine oil drain plug while the engine is hot. Hot oil will gush out of the oil tank and severely scald any persons in the general area of the pump.



CAUTION

- **NEVER** touch the hot exhaust manifold, muffler or cylinder. Allow these parts to cool before servicing equipment.



NOTICE

- **NEVER** run engine without an air filter or with a dirty air filter. Severe engine damage may occur. Service air filter frequently to prevent engine malfunction.
- **NEVER** tamper with the factory settings of the engine or engine governor. Damage to the engine or equipment can result if operating in speed ranges above the maximum allowable.



FUEL SAFETY

DANGER

- **DO NOT** add fuel to equipment if it is placed inside truck bed with plastic liner. Possibility exists of explosion or fire due to static electricity.

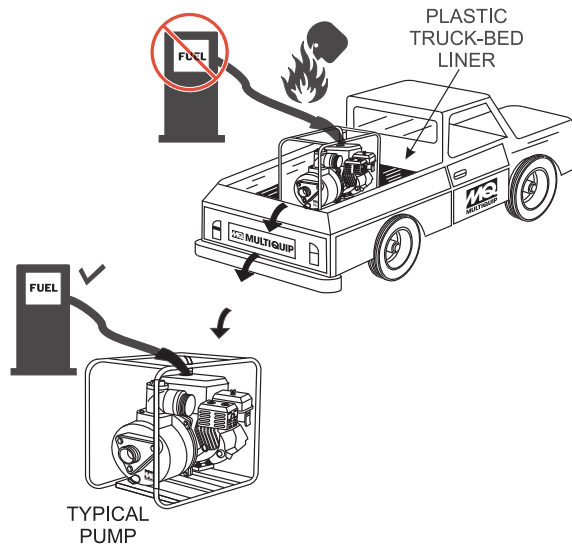



- **DO NOT** start the engine near spilled fuel or combustible fluids. Fuel is extremely flammable and its vapors can cause an explosion if ignited.
- **ALWAYS** refuel in a well-ventilated area, away from sparks and open flames.
- **ALWAYS** use extreme caution when working with **flammable** liquids.
- **DO NOT** fill the fuel tank while the engine is running or hot.
- **DO NOT** overfill tank, since spilled fuel could ignite if it comes into contact with hot engine parts or sparks from the ignition system.
- Store fuel in appropriate containers, in well-ventilated areas and away from sparks and flames.
- **NEVER** use fuel as a cleaning agent.
- **DO NOT** smoke around or near the equipment. Fire or explosion could result from fuel vapors or if fuel is spilled on a hot engine. 

BATTERY SAFETY (ELECTRIC START ONLY)

DANGER

- **DO NOT** drop the battery. There is a possibility that the battery will explode.
- **DO NOT** expose the battery to open flames, sparks, cigarettes, etc. The battery contains combustible gases and liquids. If these gases and liquids come into contact with a flame or spark, an explosion could occur. 

WARNING

- **ALWAYS** wear safety glasses when handling the battery to avoid eye irritation. The battery contains acids that can cause injury to the eyes and skin. 
- Use well-insulated gloves when picking up the battery.
- **ALWAYS** keep the battery charged. If the battery is not charged, combustible gas will build up.
- **DO NOT** charge battery if frozen. Battery can explode. When frozen, warm the battery to at least 61°F (16°C).
- **ALWAYS** recharge the battery in a well-ventilated environment to avoid the risk of a dangerous concentration of combustible gases.
- If the battery liquid (dilute sulfuric acid) comes into contact with **clothing or skin**, rinse skin or clothing immediately with plenty of water. 
- If the battery liquid (dilute sulfuric acid) comes into contact with **eyes**, rinse eyes immediately with plenty of water and contact the nearest doctor or hospital to seek medical attention.

CAUTION

- **ALWAYS** disconnect the **NEGATIVE** battery terminal before performing service on the equipment.
- **ALWAYS** keep battery cables in good working condition. Repair or replace all worn cables.

TRANSPORTING SAFETY

⚠ CAUTION

- **NEVER** allow any person or animal to stand underneath the equipment while lifting.

NOTICE

- Before lifting, make sure that the equipment parts (hook and vibration insulator) are not damaged and screws are not loose or missing.
- Always make sure crane or lifting device has been properly secured to the lifting bail (hook) of the equipment.
- **ALWAYS** shutdown engine before transporting.
- **NEVER** lift the equipment while the engine is running.
- Tighten fuel tank cap securely and close fuel cock to prevent fuel from spilling.
- Use adequate lifting cable (wire or rope) of sufficient strength.
- Use one point suspension hook and lift straight upwards.



- **DO NOT** lift machine to unnecessary heights.
- **ALWAYS** tie down equipment during transport by securing the equipment with rope.

ENVIRONMENTAL SAFETY

NOTICE

- Dispose of hazardous waste properly. Examples of potentially hazardous waste are used motor oil, fuel and fuel filters. 
- **DO NOT** use food or plastic containers to dispose of hazardous waste.
- **DO NOT** pour waste, oil or fuel directly onto the ground, down a drain or into any water source.

QP2TH — SPECIFICATIONS/DIMENSIONS (PUMP)

Table 1. Specifications (Pump)		
Pump	Model	QP-2TH
	Type	Trash Pump
	Suction & Discharge Size	2.00 in. (51 mm.)
	Maximum Pumping Capacity	211 gallons/minute (800 liters/minute)
	Max. Solids Diameter	1.00 in. (25.4 mm.)
	Max. Head	98 ft. (30.0 meters)
	Max. Pressure	42 psi (2.9 bar)
Dimension (L x W x H)		25.3 x 17.2 X 18.8 in. (642 X 437 X478 mm.)
Dry Net Weight		97 lbs. (44 Kg.)

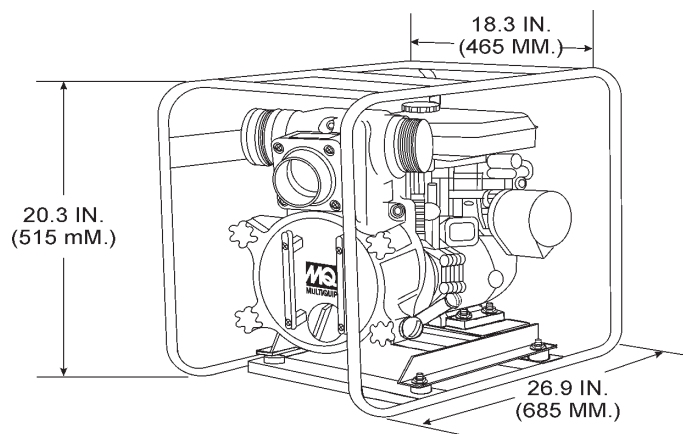
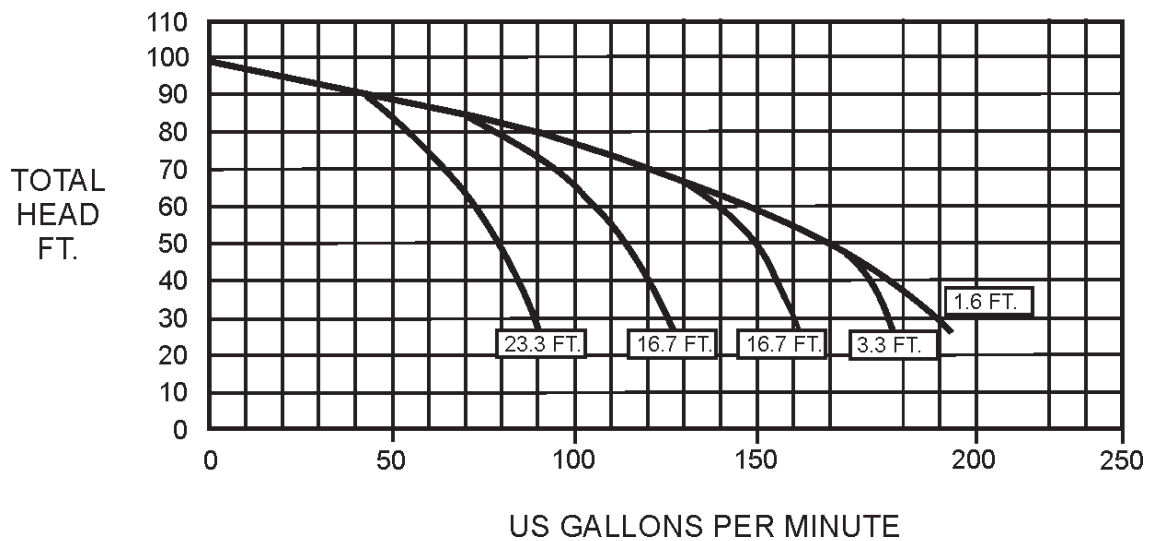

Figure 1. QP2THDimensions

QP2TH — SPECIFICATIONS/DIMENSIONS (ENGINE)

Table 2. Specifications (Engine)

Engine	Model	HONDA GX160K1QX2/GX160U1QX2
	Type	Air-cooled 4 stroke, Single Cylinder, OHV, Horizontal Shaft Gasoline Engine
	Bore X Stroke	2.7 in. x 1.8 in. (68 mm x 45 mm)
	Displacement	163 cc (9.9 cu-in)
	Max Output	4.8 H.P./3600 R.P.M.
	Fuel Tank Capacity	Approx. 0.81 U.S. gallons (3.1 liters)
	Fuel	Unleaded Automobile Gasoline
	Lube Oil Capacity	0.63 qts. (.60 liters)
	Speed Control Method	Centrifugal Fly-weight Type
	Starting Method	Recoil Start
Dimension (L x W x H)		12.0 x 14.4 x 13.6 in. (304 x 362 x 346 mm)
Dry Net Weight		3.1 lbs (15 Kg.)

QP2TH — GENERAL INFORMATION

APPLICATION

The **Multiquip QP2TH Trash Pump** is designed to be used for de-watering applications. Both the suction and discharge ports on the QP2TH trash pump use a 2-inch diameter opening, which allows the pump to pump at a rate of approximately 211 gallons/minute (gpm) or 800 liters/minute (lpm).

Trash or self priming pumps are designed to purge air from the suction line and create a partial vacuum in the pump body. The reduced atmospheric pressure inside the pump allows water to flow through the suction line and into the pump body. The centrifugal force created by the rotating impeller pressurizes the water and expels it from the pump.

Power Plant

This trash pump is powered by an 4.8 horsepower air cooled 4-stroke, single cylinder **HONDA GX-160** gasoline engine that incorporates a low "**Oil Alert Feature**"

Oil Alert Feature

In the event of **low oil** or **no oil**, the HONDA GX-160 engine has a built-in oil alarm engine shut-down feature. In the event the oil level is low the engine will automatically shut-down.

Trash Pump

Trash pumps derive their name from their ability to handle a greater amount of debris and solids than standard centrifugal pumps. These pumps generally handle solids up to 1/2 the size of the discharge opening making them less likely to clog. Also trash pumps are capable of handling water with 25% solids by weight.

The advantage of using a trash pump is that it can be quickly and easily disassembled in the field "**without tools**" and easily cleaned when clogged.

Suction Lift

This pump is intended to be used for dewatering applications and is capable of suction lifts up to 25 feet at sea level. For optimal suction lift performance keep the suction hose or line as short as possible. In general always place the pump as close to the water as possible.

Pump Support

The pump should always be placed on **solid stationary ground** in a level position.

NEVER place the pump on **soft soil**. The suction hose or pipe connection should always be checked for tightness and leaks. A small suction leak in the hose or fittings could prevent the pump from priming.

Elevation

Higher elevations will effect the performance of the pump. Due to less atmospheric pressure at higher altitudes, pumps **DO NOT** have the priming ability that they have at sea level. This is due to the "thinner air" or lack of oxygen at higher altitudes.

A general rule of thumb is that for every 1,000 feet of elevation above sea level a pump will lose one foot of priming ability.

For example, in Flagstaff, Arizona where the elevation is approximately 7,000 feet, the pump would have a suction lift of only 18 feet rather than the 25 feet at sea level. Table 3 shows suction lift at various elevations.

Table 3. Suction Lift at Various Elevations

Altitude Feet (Meters)	Suction Lift in Feet (Meters)			
	Sea Level	10.0 (3.048)	15.0 (4.572)	20.0 (6.096)
2,000 (610)	8.80 (2.680)	13.2 (4.023)	17.6 (5.364)	22.0 (6.705)
4,000 (1,219)	7.80 (2.377)	11.7 (3.566)	15.6 (4.754)	19.5 (5.943)
6,000 (1,829)	6.90 (2.103)	10.4 (3.169)	13.8 (4.206)	17.3 (5.273)
8,000 (2,438)	6.20 (1.889)	9.30 (2.834)	12.4 (3.779)	15.5 (4.724)
10,000 (3,048)	5.70 (1.737)	8.60 (2.621)	11.4 (3.474)	14.3 (4.358)

Table 4 shows percentage drops in performance as elevation increases.

Table 4. Performance Loss at Various Elevations

Altitude Feet (Meters)	Discharge Flow	Discharge Head
Sea Level	100%	100%
2,000 (610)	97%	95%
4,000 (1,219)	95%	91%
6,000 (1,829)	93%	87%
8,000 (2,438)	91%	83%
10,000 (3,048)	88%	78%

QP2TH — PUMP COMPONENTS

Figure 2 shows a typical application using the QP2TH trash pump. Please note that this pump is intended for the removal of clean water and water containing some debris and solids. Maximum size of solids should not exceed 1 inch (25.4 mm) in diameter. **DO NOT** set strainer on bottom of water bed. Placing the strainer above the water bed will prevent the pump from drawing in excessive amounts of sand and foreign debris.

Figure 2. QP2TH Pump Application

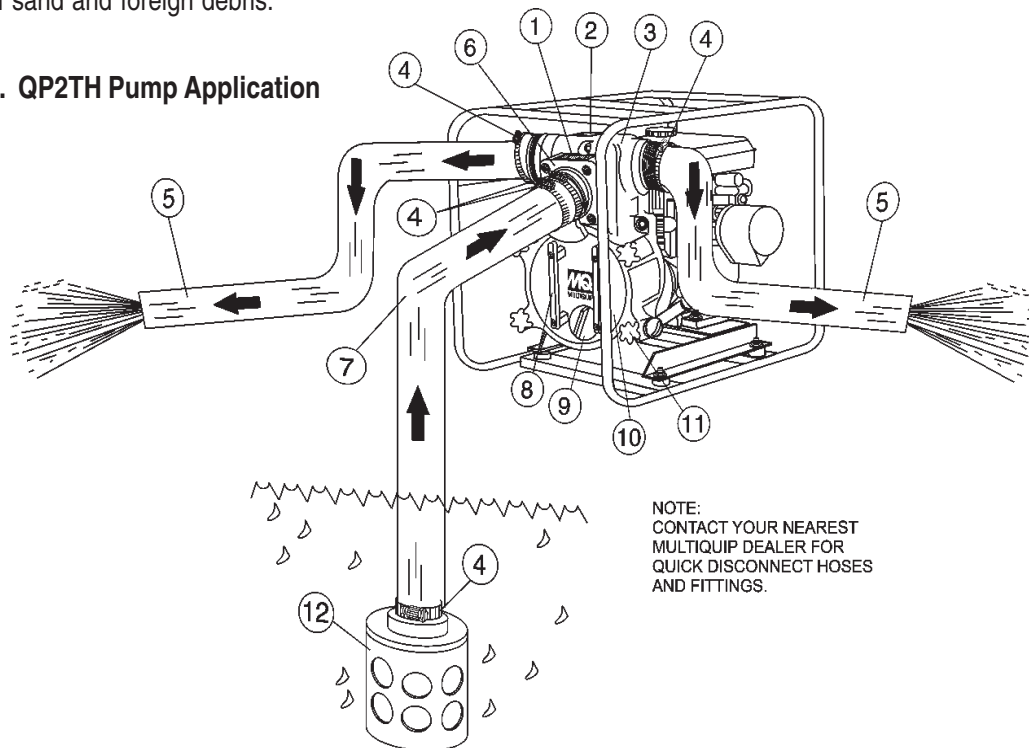

NOTE:
CONTACT YOUR NEAREST
MULTIQUIP DEALER FOR
QUICK DISCONNECT HOSES
AND FITTINGS.

1. **Pump** – The model QP2TH is a 2-inch trash pump used in general de-watering applications. Typical dewatering applications consist of manholes, septic tanks, fast and slow seepage ditch water, silt water, mud water and muck water.
2. **Fill Cap** – Prior to operation, the pump casing should be filled with water. Remove this cap to add water to the pump. After the initial prime, a sufficient amount of water will be retained in the casing so that the operator will not need to re-prime later.
If the casing is dry or has insufficient water, the pump will have difficulty in priming which could lead to premature mechanical seal wear thus causing damage to the pump.
3. **Discharge Port** – Connect a 2-inch discharge hose to this port. Note there are 2 ports.
4. **Worm Clamp** – Used to secure the hose to the inlet and outlet ports on the pump. Use two clamps to secure the hose on the inlet side of the pump.
5. **Discharge Hose** – Connect a flexible rubber hose to the discharge port on the pump. Make sure that the hose lays flat and is not kinked. Use only recommended type discharge hose. Contact Multiquip parts department for ordering information.
6. **Suction Port** – Connect a 2-inch inlet hose to this port. Use two worm clamps to secure the hose.
7. **Suction Hose** – Connect flexible rubber hose to the suction port on the pump. Make sure that the hose lays flat and is not kinked. Use only recommended type suction hose. Contact Multiquip parts department for ordering information.
8. **Clean-out Cover Handles** – To gain access to the pump's clean-out area, grip both handles, then pull to remove cover. Make sure both locking knobs have been released before attempting to remove clean-out cover.
9. **Drain Plug** – Remove this plug to drain water from the pump.
10. **Clean-out Cover** – Remove cover to gain access to the clean-out area.
11. **Locking Knobs** – Turn both knobs clockwise to secure clean-out cover, turn counter-clockwise to release cover.
12. **Strainer** – Always attach a strainer to bottom side of the suction hose to prevent large objects and debris from entering the pump. Strainer should be positioned so that it will remain completely under water. Running the pump with the strainer above water for long periods can damage pump.

! DANGER - Fueling The Engine

If pump is placed in a truck bed with a plastic liner, **REMOVE** pump from truck bed and place on ground (Figure 3) to refuel. The possibility of **fire** or **explosion** exists, due to static electricity.

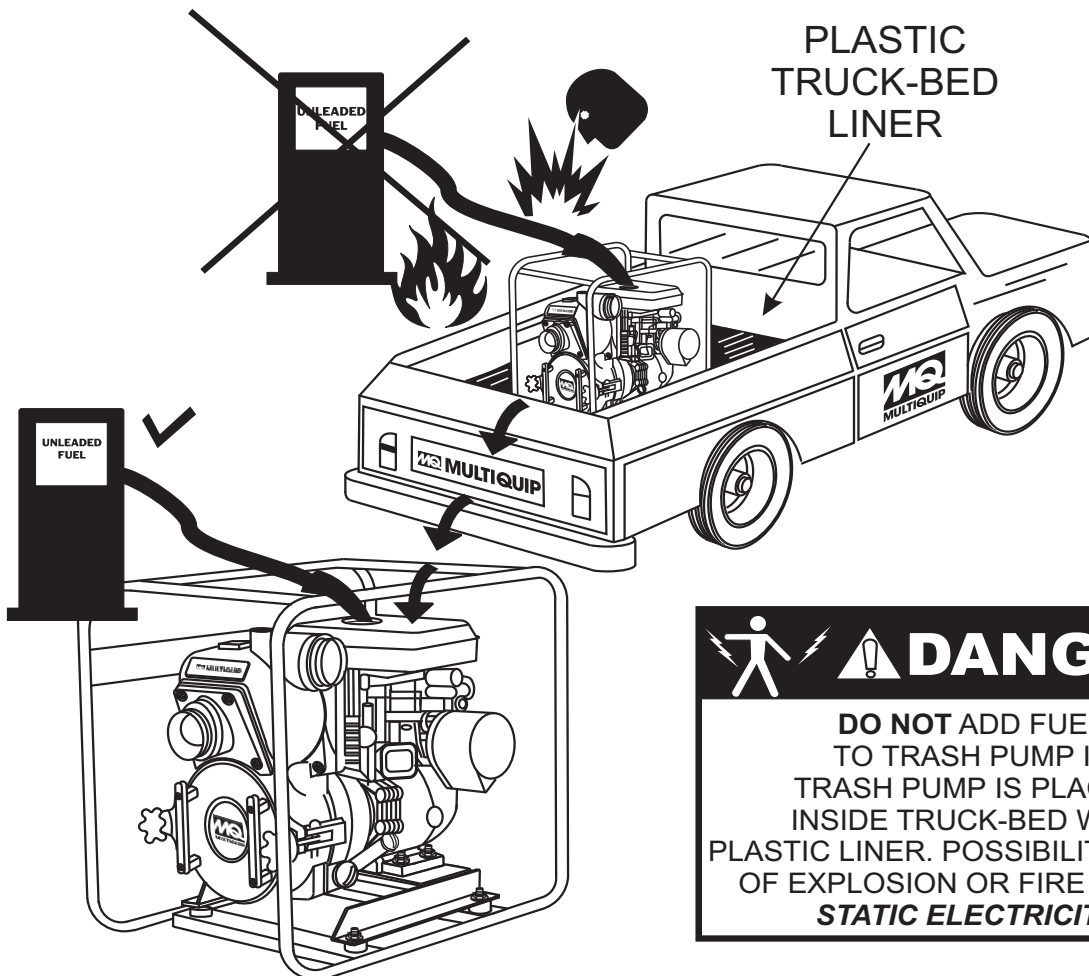

! DANGER
DO NOT ADD FUEL TO TRASH PUMP IF TRASH PUMP IS PLACED INSIDE TRUCK-BED WITH PLASTIC LINER. POSSIBILITY EXISTS OF EXPLOSION OR FIRE DUE TO STATIC ELECTRICITY.

Figure 3. Pump Refueling

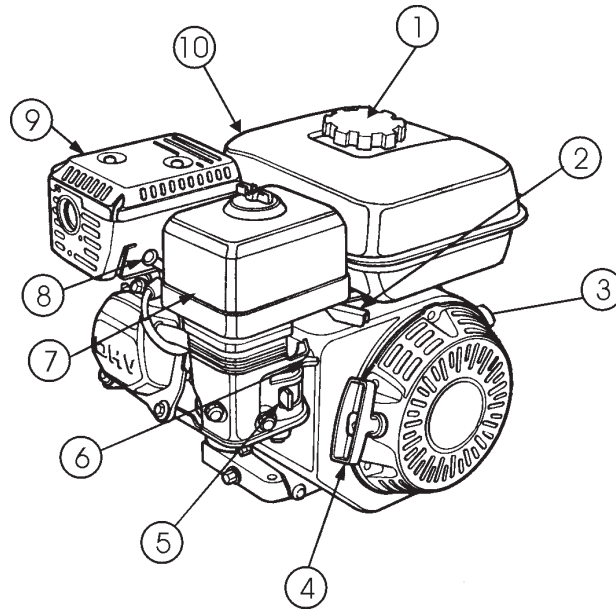

Figure 4. Engine Controls and Components

INITIAL SERVICING

The engine (Figure 4) must be checked for proper lubrication and filled with fuel prior to operation. Refer to the manufacturers engine manual for instructions and details of operation and servicing. The engine shown above is a **HONDA** engine, operation for other types of engines may vary somewhat.

1. **Fuel Filler Cap** – Remove this cap to add unleaded gasoline to the fuel tank. Make sure cap is tightened securely. **DO NOT** over fill.

CAUTION - Fueling The Engine

Adding fuel to the tank should be done only when the engine is stopped and has had an opportunity to cool down. In the event of a fuel spill, **DO NOT** attempt to start the engine until the fuel residue has been completely wiped up, and the area surrounding the engine is dry.



2. **Throttle Lever** – Used to adjust engine RPM speed (lever advanced forward **SLOW**, lever back toward operator **FAST**).
3. **Engine ON/OFF Switch** – ON position permits engine starting, OFF position stops engine operations.
4. **Recoil Starter (pull rope)** – Manual-starting method. Pull the starter grip until resistance is felt, then pull briskly and smoothly.
5. **Fuel Valve Lever** – **OPEN** to let fuel flow, **CLOSE** to stop the flow of fuel.

6. **Choke Lever** – Used in the starting of a cold engine, or in cold weather conditions. The choke enriches the fuel mixture.
7. **Air Cleaner** – Prevents dirt and other debris from entering the fuel system. Remove wing-nut on top of air filter cannister to gain access to filter element.

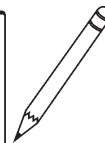
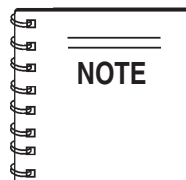

Operating the engine without an air filter, with a damaged air filter, or a filter in need of replacement will allow dirt to enter the engine, causing rapid engine wear.

CAUTION - Burn Hazard

Engine components can generate extreme heat. To prevent burns, **DO NOT** touch these areas while the engine is running or immediately after operating. **NEVER** operate the engine with the muffler removed.



8. **Spark Plug** – Provides spark to the ignition system. Set spark plug gap to 0.6 - 0.7 mm (0.028 - 0.031 inch) Clean spark plug once a week.
9. **Muffler** – Used to reduce noise and emissions.
10. **Fuel Tank** – Holds unleaded gasoline. For additional information refer to engine owner's manual.

QP2TH — PRE-INSPECTION (ENGINE)

Pre-Inspection (Engine)

1. Read safety instructions at the beginning of manual.
2. Clean the pump, removing dirt and dust, particularly the engine cooling air inlet, carburetor and air cleaner.
3. Check the air filter for dirt and dust. If air filter is dirty, replace air filter with a new one as required.
4. Check carburetor for external dirt and dust. Clean with dry compressed air.
5. Check fastening nuts and bolts for tightness.



3. Insert and remove the dipstick without screwing it into the filler neck. Check the oil level shown on the dipstick.
4. If the oil level is low (Figure 6), fill to the edge of the oil filler hole with the recommended oil type (Table 5). Maximum oil capacity is 0.63 quarts (0.60 liters)

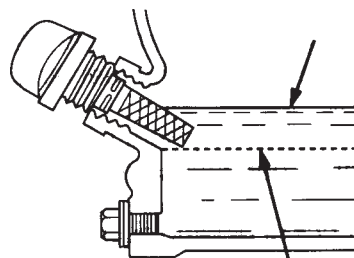

Figure 6. Engine Oil Dipstick (Oil Level)

Engine Oil Check

1. To check the engine oil level, place the pump on secure level ground with the engine stopped.
2. Remove the filler dipstick from the engine oil filler hole (Figure 5) and wipe clean.

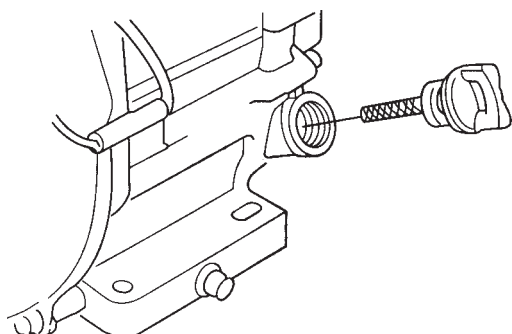

Figure 5. Engine Oil Dipstick (Removal)

Table 5. Oil Type

Season	Temperature	Oil Type
Summer	25°C or Higher	SAE 10W-30
Spring/Fall	25°C~10°C	SAE 10W-30/20
Winter	0°C or Lower	SAE 10W-10

! WARNING - Explosive Fuel

Diesel is extremely flammable, and its vapors can cause an explosion if ignited. **DO NOT** start the engine near spilled fuel or combustible fluids. **DO NOT** smoke while refueling. **DO NOT** attempt to refuel the pump if the engine is **hot!** or **running**.



Fuel Check

1. Remove the gasoline cap located on top of fuel tank.
2. Visually inspect to see if the fuel level is low. If fuel is low, replenish with unleaded fuel.
3. When refueling, be sure to use a strainer for filtration. **DO NOT** top-off fuel. Wipe up any spilled fuel **immediately!**

Before Starting

1. Read safety instructions at the beginning of manual.
2. Place pump as near to water as possible, on a firm flat, level surface.
3. To prime pump, remove fill cap (Figure 2) and fill pump casing with water. If the pump casing is not filled with water before starting, it will not begin pumping.

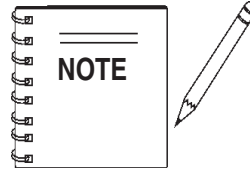

Suction and discharge hoses are available from Multiquip. Contact your nearest dealer for more information.

CAUTION - Pump Casing

Pump casing **must** be filled with water before using pump. Otherwise pump will not be able to begin pumping.

WARNING - High Pressure

DO NOT open **fill cap** if pump is **hot!** Water inside may be under pressure. The possibility exists of scalding, resulting in severe bodily harm.



4. Check for **leaks** between pump and engine. If water is leaking between the pump and engine housing, the seal inside the pump may be worn or damaged. Continued operation of the pump is not recommended. Further usage of the pump under these conditions may cause severe water damage to engine.

Hoses and Clamps

1. Check that all hoses are **securely** attached to the pump. Make certain suction hose (Figure 2) does not have any air leakage. Tighten hose clamps and couplings as required.
2. It is recommended that 2 clamps be used when securing the suction hose to the inlet side (suction) of the pump.
3. Remember suction hoses must be **rigid** enough not to collapse when the pump is in operation.
4. Check that the **discharge** hose (Figure 2) is not restricted. Place hose so that it lays as straight as it is possible on the ground. Remove any twists or sharp bends from hose which may block the flow of water.

5. The discharge hose is usually a **collapsible** (thin-walled) hose, however if a thin-walled discharge hose is not available, a rigid suction hose can be substituted in its place.
6. Make sure the **suction strainer** (Figure 2) is clean and securely attached to the water end of the suction hose. The strainer is designed to protect the pump by preventing large objects from being pulled into the pump.

CAUTION - Strainer

The strainer should be positioned so it will remain completely **under water**. Running the pump with the strainer above water for long periods can damage the pump.

CAUTION - Flammable Fluids-Chemicals

DO NOT pump flammable fluids, corrosive chemicals or fluids containing toxic substances. These fluids can create potentially dangerous health and environmental hazards. Contact local authorities for assistance.

CAUTION - Mechanical Seal

This pump uses a water-cooled **mechanical seal** to prevent water from seeping into the engine. The passage of water through the pump casing lubricates the seal and prevents it from overheating. **NEVER!** operate the pump without water in the casing as this will cause damage to the mechanical seal.

QP-2T H— INITIAL START-UP (ENGINE)

CAUTION - Read Manual

DO NOT attempt to operate the pump until the Safety, General Information and Inspection sections of this manual have been **read and thoroughly understood**.



This section is intended to assist the operator with the **initial start-up** of the trash pump. It is extremely important that this section be read carefully before attempting to use the pump in the field.

Starting the Engine (HONDA engine)

1. Place the engine **fuel valve lever** (Figure 7) to the "ON" position.

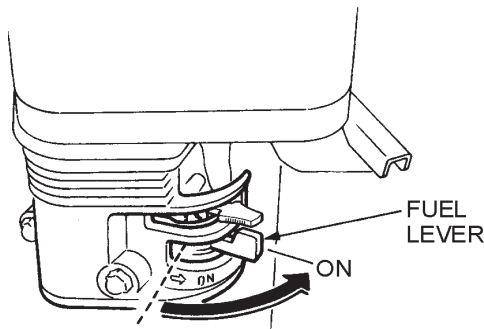

Figure 7. Engine Fuel Valve Lever (ON Position)

2. Move the **throttle lever** (Figure 8) away from the slow position, about 1/3 of the way toward the fast position.

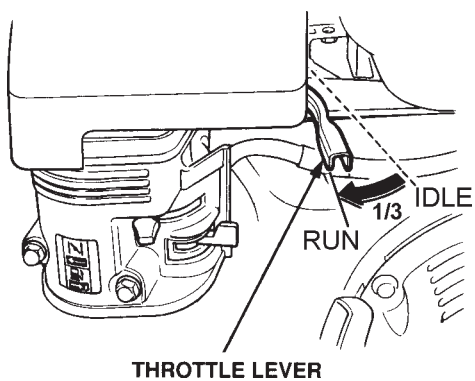

Figure 8. Throttle Lever (1/3 Start Position)

3. Place the **choke lever** (Figure 9) in the "CLOSED" position if starting a **cold** engine.

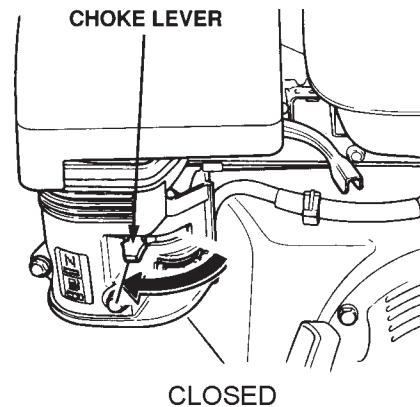

Figure 9. Engine Choke Lever (Closed)

4. Place the **choke lever** (Figure 10) in the "OPEN" position if starting a **warm engine** or the **temperature is warm**.

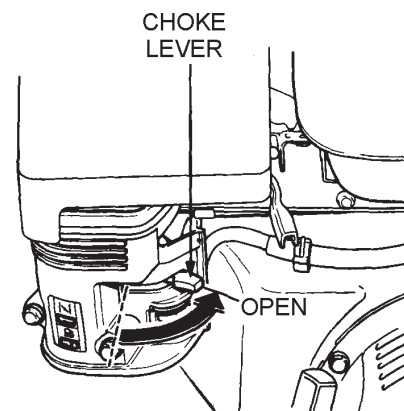

Figure 10. Engine Choke Lever (Open)

5. Place the **engine ON/OFF switch** (Figure 11) in the "ON" position.

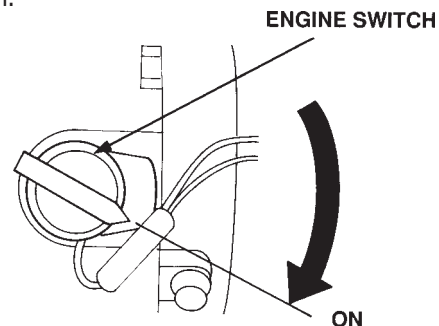

Figure 11. Engine ON/OFF Switch (ON Position)

QP2TH — INITIAL START-UP (ENGINE)

- Grasp the starter grip (Figure 12) and slowly pull it out. The resistance becomes the hardest at a certain position, corresponding to the compression point. Pull the starter grip briskly and smoothly for starting.

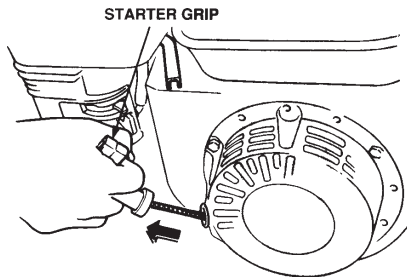

Figure 12. Starter Grip

- If the engine has started, slowly return the choke lever (Figure 13) to the "OPEN" position. If the engine has not started repeat steps 1 through 6.

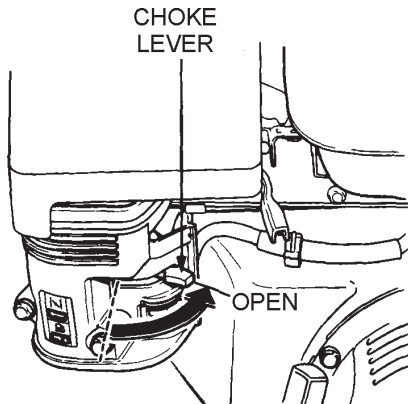

Figure 13. Choke Lever (Open)

- Before the pump is placed into operation, run the engine for several minutes. Check for fuel leaks, and noises that would associate with a loose component.
- To begin pumping, place the throttle lever (Figure 14) in the "RUN" position.

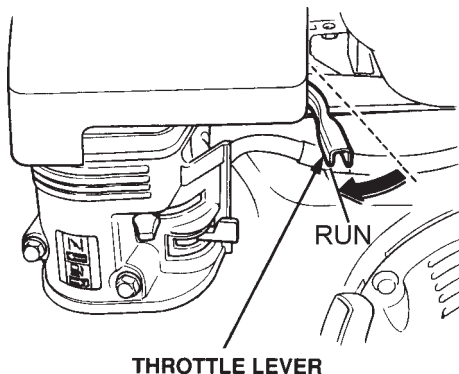

Figure 14. Throttle Lever (Run)

CAUTION - Maximum Engine Speed

ALWAYS run engine at **full speed** while pumping.

Stopping The Engine

Normal Shutdown

- Move the throttle lever to the **IDLE** position (Figure 15) and run the engine for three minutes at low speed.

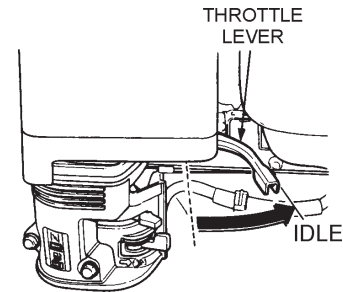

Figure 15. Throttle Lever (Idle)

- After the engine **cools**, turn the engine ON/OFF switch to the "OFF" position (Figure 16).

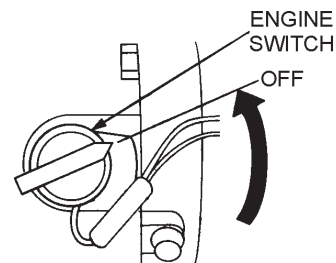

Figure 16. Engine ON/OFF Switch (OFF)

- Place the **fuel shut-off lever** (Figure 17) in the **OFF** position.

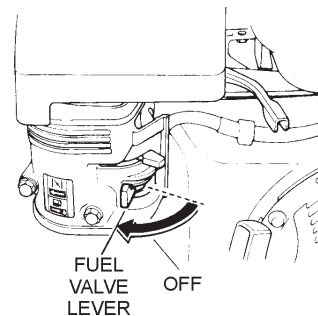

Figure 17. Fuel Valve Lever (OFF)

Emergency Showdown

- Move the throttle lever quickly to the **IDLE** position, and place the engine ON/OFF switch in the **OFF** position.

Pump Vacuum Test

CAUTION - Pump Priming

DO NOT attempt to start the engine unless the pump has previously been **primed** with water. Severe pump damage will occur if pump has not been primed.

To perform the pump vacuum test do the following:

1. Remove the pump fill cap (Figure 2), and fill the pump with water.
2. Start the engine as outlined in the initial start-up section, and wait for the pump to begin pumping.
3. As shown in Figure 18, place a water hose inside the discharge opening of the pump, and turn on the water. This flow of water into the discharge opening will **prevent** the pump from running dry.
4. Place the **Pump Vacuum Tester** (P/N 7000030) over the pump suction (inlet) opening (Figure 18) with the vacuum gauge facing upwards. It may be necessary to apply a small amount of water around the rubber seal of the vacuum tester to make a good suction fit.
5. Check and make sure that there are no air leaks between the vacuum tester and the inlet port on the pump. If air leaks are present reseal vacuum tester.
6. Run the pump for a few minutes while monitoring the vacuum gauge. If the gauge indicates a reading between -25 and -20 in. Hg. (inches of mercury) then it can be assumed that the pump is working correctly.

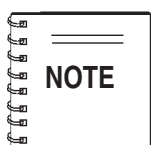

25 in. Hg (inches of mercury) translates into 25 feet of lift at **sea level**.

7. If the vacuum tester gauge indicates a reading **below** -20 in. Hg, it can then be assumed that the pump is not functioning correctly, and corrective action needs to be taken.
8. To test the **flapper valve**, shut down the engine. The vacuum tester should remain attached to the pump suction inlet port by vacuum. This indicates the pump's flapper valve is seating properly to hold water in the suction hose when the engine is stopped. This prevents backflow and allows for faster priming when the engine is restarted.

Adjusting Impeller Clearance

1. If it is necessary to replace impeller or volute, be sure clearance between impeller and volute is adjusted correctly.
2. The impeller should be as close to the volute as possible without rubbing against it. Clearance is adjusted by adding or removing **shims** from behind the impeller.
3. Check clearance between impeller and insert by slowly pulling starter rope to turn impeller. Remove spark plug to make it easier to turn impeller.

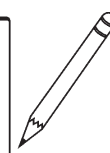
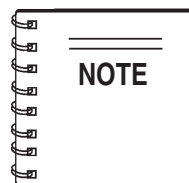

It is important not to remove too many shims or the clearance between the impeller and volute will become **too wide** and pump performance will be reduced. Remember as the impeller wear down, additional shims may be required to maintain the clearance between the impeller and insert.

4. Check the impeller **every six months** for wear, and for clearance between the impeller face and the volute. Also check the shaft seal for wear, as well as the shaft sleeve.

Pump Cleaning

After pumping water containing large amounts of dirt and debris, perform the following:

1. Remove the drain plug from the pump housing (Figure 2) and drain any water left in the pump.
2. Loosen the two locking hand knobs (turn counter-clockwise) and remove **clean-out cover**.
3. Clean and remove dirt, debris from pump casing. Inspect impeller and volute for wear. Replace any damaged or worn parts.

CAUTION

The impeller may develop **sharp edges**. Use extreme care when cleaning around the impeller to prevent being cut.

CAUTION
DO NOT RUN PUMP
WITHOUT WATER.

PLACE VACUUM TESTER
OVER PUMP SUCTION PORT

DISCHARGE
PORT

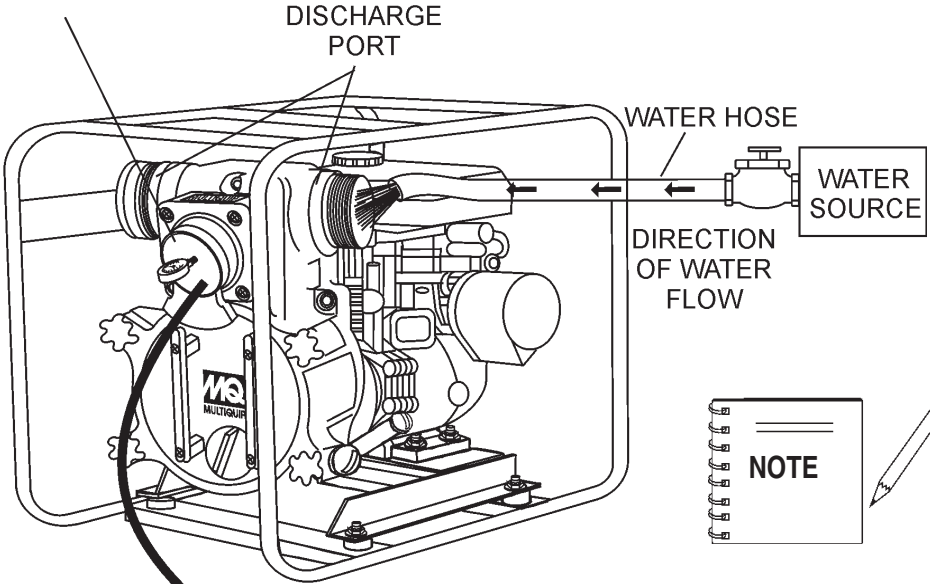

Pressure reading may vary depending on altitude. See Tables 3 and 4 on page 12.

ACCEPTABLE READING
SHOULD BE BETWEEN
-25 AND -20 IN. HG.

25 IN. HG. TRANSLATES
INTO 25 FEET OF LIFT
AT SEA LEVEL.

PUMP VACUUM
TESTER

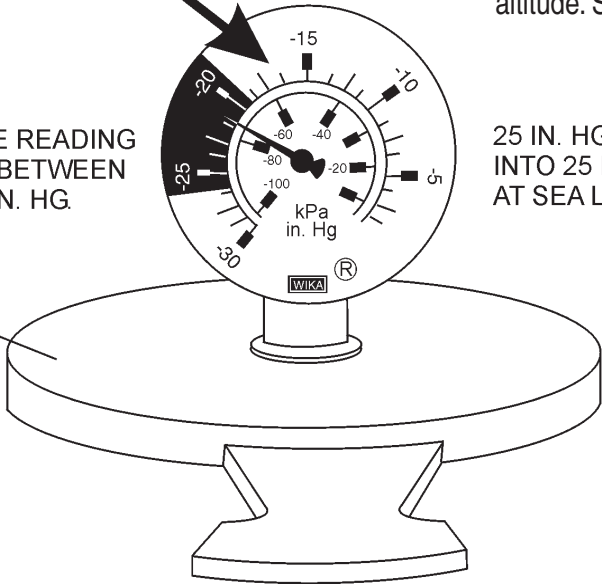

Figure 18. Pump Vacuum Tester

Engine Maintenance

Perform engine maintenance procedures as referenced by Table 6 below:

Table 6. Engine Maintenance Schedule							
DESCRIPTION (3)	OPERATION	BEFORE	FIRST MONTH OR 10 HRS.	EVERY 3 MONTHS OR 25 HRS.	EVERY 6 MONTHS OR 50 HRS.	EVERY YEAR OR 100 HRS.	EVERY 2 YEARS OR 200 HRS.
Engine Oil	CHECK	X					
	CHANGE		X				
Air Cleaner	CHECK	X					
	CHANGE			X (1)			
All Nuts & Bolts	Re-tighten If Necessary	X					
Spark Plug	CHECK-CLEAN				X		
	REPLACE						X
Cooling Fins	CHECK				X		
Spark Arrester	CLEAN					X	
Fuel Tank	CLEAN					X	
Fuel Filter	CHECK					X	
Idle Speed	CHECK-ADJUST					X (2)	
Valve Clearance	CHECK-ADJUST						X (2)
Fuel lines	CHECK	Every 2 years (replace if necessary) (2)					

(1) Service more frequently when used in **DUSTY** areas.

(2) These items should be serviced by your servc dealer, unless you have the proper tools and are mechanically proficient. Refer to the HONDA shop Manual for service procedures

(3) For commercial use, log hours of operation to determine proper maintenance intervals.

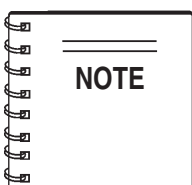

Reference manufacturer engine manual for specific servicing instructions.

Maintenance

Perform the engine maintenance procedures as indicated below:

DAILY

- Thoroughly remove dirt and oil from the engine and control area. Clean or replace the air cleaner elements as necessary. Check and retighten all fasteners as necessary. Check the spring box and bellows for oil leaks. Repair or replace as needed.

WEEKLY

- Remove the fuel filter cap and clean the inside of the fuel tank.
- Remove or clean the filter at the bottom of the tank.
- Remove and clean the spark plug (Figure 19), then adjust the spark gap to 0.028 ~0.031 inch (0.6~0.7 mm). This unit has electronic ignition, which requires no adjustments.

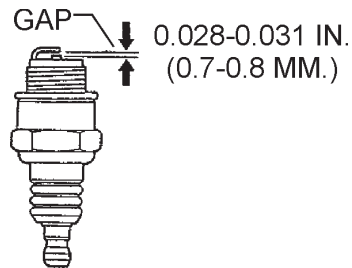

Figure 19. Spark Plug Gap

ENGINE OIL

- Drain the engine oil when the oil is **warm** as shown in Figure 20.
- Remove the oil drain bolt and sealing washer and allow the oil to drain into a suitable container.
- Replace engine oil with recommended type oil as listed in Table 5. Engine oil capacity is 1.16 quarts (1.1 liters). **DO NOT** overfill.
- Install drain bolt with sealing washer and tighten securely.

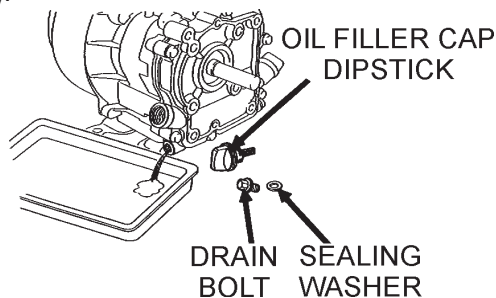

Figure 20. Engine Oil (Draining)

! DANGER - Cleaning Solvents

The **DO NOT** use gasoline as a cleaning solvent, because that would create a risk of fire or explosion.



ENGINE AIR CLEANER

- Remove the air cleaner cover and foam filter element as shown in Figure 21.
- Tap the paper filter element (Figure 21) several times on a hard surface to remove dirt, or blow compressed air [not exceeding 30 psi (207 kPa, 2.1 kgf/cm²)] through the filter element from the air cleaner case side. **NEVER** brush off dirt. Brushing will force dirt into the fibers. Replace the paper filter element if it is excessively dirty.
- Clean foam element in warm, soapy water or nonflammable solvent. Rinse and dry thoroughly. Dip the element in clean engine oil and completely squeeze out the excess oil from the element before installing.

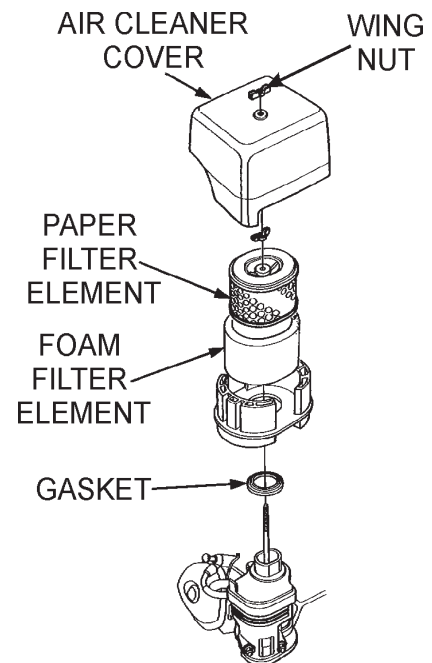

Figure 21. Engine Air Cleaner

Pump Storage

For storage of the pump for over 30 days, the following is required:

- Drain the fuel tank completely.
- Run the engine until the fuel in the injection system is completely consumed.
- Completely drain used oil from the engine crankcase and fill with fresh clean oil, then follow the procedures described in the engine manual for engine storage.
- Remove the drain plug from the pump and drain out any water from left in the housing.
- Remove the pump cover and clean inside of pump housing. Coat inside of pump housing with a light film of oil to reduce corrosion. A spray can of oil works well for this application.
- Cover suction and discharge ports with duct tape to prevent any foreign matter from falling into pump.
- Cover pump and engine with plastic covering or equivalent and store in a clean, dry place.
- To protect the water cooled-seals, place one-half pint of lubricating oil (new or used) through the discharge opening on the pump and crank the engine several times. This will prevent excessive corrosion and also keep the mechanical seal lubricated.

QP2TH — TROUBLESHOOTING (ENGINE)

TABLE 7. ENGINE TROUBLESHOOTING

SYMPTOM	POSSIBLE PROBLEM	SOLUTION
Difficult to start		
Fuel is available but spark plug will not ignite. (Power available at high tension cable).	Ignition plug being bridge?	Check ignition system.
	Carbon deposit at ignition?	Clean or replace ignition.
	Short circuit due to defective insulators?	Replace insulators.
	Improper spark gap?	Set spark plug gap to the correct gap.
Fuel is available but spark plug will not ignite. (Power NOT available at high tension cable).	Short circuit at stop switch?	Check stop switch circuit. Replace stop switch if defective.
	Ignition coil defective?	Replace ignition coil.
Fuel is available and spark plug ignites (compression normal).	Muffler clogged with carbon deposits?	Clean or replace muffler.
	Mixed fuel quality is inadequate?	Check fuel to oil mixture.
	Fuel in use inadequate (water, dust)?	Flush fuel sytem and replace with fresh fuel.
	Air Cleaner clogged?	Clean or replace air cleaner.
Fuel is available and spark plug ignites (compression low).	Defective cylinder head gasket?	Tighten cylinder head bolts or replace head gasket.
	Cylinder worn?	Replace cylinder.
	Spark plug loose?	Tighen spark plug.
Operation not satisfactory		
Not enough power available (compression normal, no miss-firing).	Air cleaner clogged?	Clean or replace air cleaner.
	Air in fuel line?	Bleed (remove air) from fuel line.
	Fuel level in carbureator float chamber improper?	Adjust carbureator float
	Carbon deposits in cylinder?	Clean or replace cylinder
Not enough power available (compression normal, miss-firing).	Ignition coil defective?	Flush fuel sytem and replace with fresh fuel.
	Ignition plug often shorts?	Replace ignition wires, clean ignition.
	Fuel in use inadequate (water, dust)?	Flush fuel sytem and replace with fresh fuel.
Engine overheats.	Excessive carbon depostion in combustion chamber?	Clean or replace crankcase.
	Exhaust or muffler clogged with carbon.	Clean or replace muffler.
	Spark plug heat value incorrect?	Replace spark plug with correct type spark plug.

QP2TH — TROUBLESHOOTING (ENGINE/PUMP)

TABLE 7. ENGINE TROUBLESHOOTING (Continued)

SYMPTOM	POSSIBLE PROBLEM	SOLUTION
Operation not satisfactory		
Rotational speed fluctuates.	Governor adjustment improper?	Adjust governor to correct lever.
	Governor spring defective?	Clean or replace ignition.
	Fuel flow erratic?	Check fuel line.
	Air taken in through suction line?	Check suction line.
Recoil starter not working properly.	Dust in rotating part?	Clean recoil starter assembly.
	Spring spring failure?	Replace sprial spring.

TABLE 8. PUMP TROUBLESHOOTING

SYMPTOM	POSSIBLE PROBLEM	SOLUTION
Pump does not take on water.	Not enough priming water in the housing?	Add water.
	Engine speed too low?	Increase throttle.
	Strainer plugged?	Clean strainer.
	Suction hose damaged?	Replace or repair hose, and clamps
	Air leak at suction port?	Check that fittings are tight and properly sealed.
	Pump is located too high above water line?	Move pump closer to water.
	Debris collecting in pump housing?	Clean pump housing.
	Too much distance between impeller and volute.	Adjust clearance by adding shims or replace impeller. Min. .006" - Max. .020"
	Water leaking out weep hole between pump and engine?	Check condition of mechanical seal and gaskets, between pump end and engine housing.
Pump takes in water, little or no discharge.	Engine speed too low?	Increase throttle speed.
	Suction strainer partially plugged?	Clean strainer.
	Impeller/Volute worn?	Adjust clearance by adding shims or replace impeller/volute
Suction hose leaks at inlet.	Fittings/clamps are not sealed properly?	Tighten, replace or add clamp. (Keep extra seals on pump)
	Hose diameter is too large?	Use smaller diameter hose or replace hose.
Discharge does not stay on coupling.	Pressure too high?	Check pressure, add additional clamp.
	Hose kinked or end blocked?	Check hose.
Impeller does not turn: pump is hard to start.	Impeller jammed or blocked?	Open pump cover and clean dirt and debris from inside housing.
	Impeller and volute binding?	Adjust clearance by removing shim from behind impeller.
	Defective engine?	See Engine Owner's Manual.

QP2TH — EXPLANATION OF CODE IN REMARKS COLUMN

The following section explains the different symbols and remarks used in the Parts section of this manual. Use the help numbers found on the back page of the manual if there are any questions.

NOTICE

The contents and part numbers listed in the parts section are subject to change **without notice**. Multiquip does not guarantee the availability of the parts listed.

SAMPLE PARTS LIST

NO.	PART NO.	PART NAME	QTY.	REMARKS
1	12345	BOLT.....	1	INCLUDES ITEMS W/%
2%		WASHER, 1/4 IN.....		NOT SOLD SEPARATELY
2%	12347	WASHER, 3/8 IN....	1	MQ-45T ONLY
3	12348	HOSE		A/R ...MAKE LOCALLY
4	12349	BEARING	1	S/N 2345B AND ABOVE

NO. Column

Unique Symbols — All items with same unique symbol

(@, #, +, %, or >) in the number column belong to the same assembly or kit, which is indicated by a note in the “Remarks” column.

Duplicate Item Numbers — Duplicate numbers indicate multiple part numbers, which are in effect for the same general item, such as different size saw blade guards in use or a part that has been updated on newer versions of the same machine.

NOTICE

When ordering a part that has more than one item number listed, check the remarks column for help in determining the proper part to order.

PART NO. Column

Numbers Used — Part numbers can be indicated by a number, a blank entry, or TBD.

TBD (To Be Determined) is generally used to show a part that has not been assigned a formal part number at the time of publication.

A blank entry generally indicates that the item is not sold separately or is not sold by Multiquip. Other entries will be clarified in the “Remarks” Column.

QTY. Column

Numbers Used — Item quantity can be indicated by a number, a blank entry, or A/R.

A/R (As Required) is generally used for hoses or other parts that are sold in bulk and cut to length.

A blank entry generally indicates that the item is not sold separately. Other entries will be clarified in the “Remarks” Column.

REMARKS Column

Some of the most common notes found in the “Remarks” Column are listed below. Other additional notes needed to describe the item can also be shown.

Assembly/Kit — All items on the parts list with the same unique symbol will be included when this item is purchased.

Indicated by:

“INCLUDES ITEMS W/(unique symbol)”

Serial Number Break — Used to list an effective serial number range where a particular part is used.

Indicated by:

“S/N XXXXX AND BELOW”

“S/N XXXX AND ABOVE”

“S/N XXXX TO S/N XXX”

Specific Model Number Use — Indicates that the part is used only with the specific model number or model number variant listed. It can also be used to show a part is NOT used on a specific model or model number variant.

Indicated by:

“XXXXX ONLY”

“NOT USED ON XXXX”

“Make/Obtain Locally” — Indicates that the part can be purchased at any hardware shop or made out of available items. Examples include battery cables, shims, and certain washers and nuts.

“Not Sold Separately” — Indicates that an item cannot be purchased as a separate item and is either part of an assembly/kit that can be purchased, or is not available for sale through Multiquip.

QP2TH TRASH PUMP 1 TO 3 UNITS W/HONDA GX160K1QX2/GX160U1QX2 ENG.

Qty.	P/N	Description
1	1889040030	IMPELLER
1	0811883056	MECHANICAL SEAL SLEEVE
2	0631211159	FLOODING CAP
3	9807956846	SPARK PLUG
3	17210ZE2505	ELEMENT, AIR CLEANER
1	28462ZE2W11	ROPE STARTER
1	17620ZH7023	CAP, W/GASKET FUEL FILLER
2	0803442930	MECHANICAL SEAL
1	0811345443	MECHANICAL SEAL SLEEVE
2	0481571950	O-RING, DRAIN COVER
2	0489402910	O-RING, CASING
2	0482200180	O-RING, MECHANICAL SEAL SLEEVE
4	0852833020	ADJUST LINER .30
4	0852853020	ADJUST LINER .50

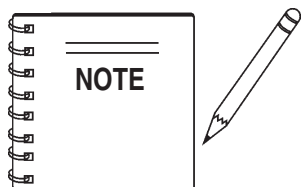

Part number on this Suggested Spare Parts List may super cede/replace the P/N shown in the text pages of this book.

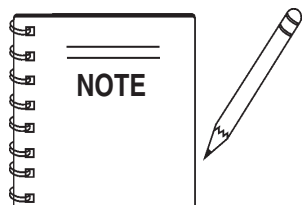

✘ GX160K1QX2: Model QP2TH S/N 2TH-3428 AND BELOW
 ◇ GX160U1QX2: Model QP2TH S/N 2TH-3429 AND ABOVE

PUMP ASSY.

<u>NO.</u>	<u>PART NO.</u>	<u>PART NAME</u>	<u>QTY.</u>	<u>REMARKS</u>
1	1889100011	CASING	1	
2	1889100020	CASING COVER	1	
3	18890001600014	SUCTION COVER	1	
4	1889100171	DRAIN COVER	1	
5	19920002200014	DRAIN COVER HANDLE	4	
6	1889040031ASSY	IMPELLER KIT	1	INCLUDES ITEMS W/# REPLACES 1889-040030
7	1889000132	VOLUTE CASING	1	
8	1889100741	SUCTION PLATE	1	
9	1247100250	DRAIN COVER SET HANDLE	2	
10	1889330410	SUCTION PLATE PACKING	1	
11	1992250700	WEAR PLATE	1	
12	0191190525	BOLT(CASING COVER), 5/16-24 UNF	4	
13	07904320200014	NIPPLE, NPS2" X NPT2"	2	
14	1889350351	CHECK VALVE	1	
15	0105090840	BOLT (ENGINE), M8 X40	4	
16	1211390610	CASING COVER PACKING, OIL SHEET	1	
17	0481571950	O'RING (DRAIN COVER)	1	
18	0489402910	O'RING (CASING), 4 X 291 MM	1	
19	1889214010P002	BASE, SS400	1	
20	0481310550	O'RING (NIPPLE)	2	
21#	0482200180	O'RING" (MECHANICAL SEAL SLEEVE)	2	
22	18892140200014	ENGINE BASE, SS400	1	
23	0631211159	FLOODING CAP, PF1-1/2"	1	
24	0631211159	DRAIN CAP, PF1-1/2"	1	
25	0803442930	MECHANICAL SEAL	1	
26	0811345443	MECHANICAL SEAL SLEEVE, DIA. 25MM	1	
27	0852833020	ADJUST LINER DIA. 20 X 30 MM TO.3	1	
27-1	0852853020	ADJUST LINER DIA. 20 X 30 MM TO.5	1	
28#	0191190544	BOLT(IMPELLER), 5/16-24 UNF X 1-3/4	1	REPLACES P/N 0191190525
29	0141090820QP2	SCREW (VOLUTE CASING) M8 X 20	2	
30	0141090825	SCREW (DRAIN COVER SET HANDLE) M8 X 25	4	
31	0131191270	CAP SCREW (CASING), M12 X 70	1	
32	0131191235	CAP SCREW (CASING), M12 X 35	4	
33	0105091035	BOLT (PUMP), M10 X 35	2	
34	0459220120	SEAL WASHER (CASING) M12	1	
35	0723302040	CUSHION RUBBER, 40 X 20 M10	4	
36	0181090820	BOLT SET W/SPRING WASHER M8 X 20 (SUCTION PLATE)	2	
37	0181090825	BOLT SET WITH SPRING WASHER M8 X 25 (SUCTION COVER)	4	



ITEM 21, O-RING, IS INCLUDED IN IMPELLER KIT, ITEM 6. WHEN ORDERED AS PART OF THE KIT, QUANTITY OF O-RING IS ONE. REPLACEMENT OF IMPELLER REQUIRES TWO O-RINGS, SO IT IS NECESSARY TO ORDER ONE ADDITIONAL O-RING.

QP2TH — PUMP ASSY.

PUMP ASSY.

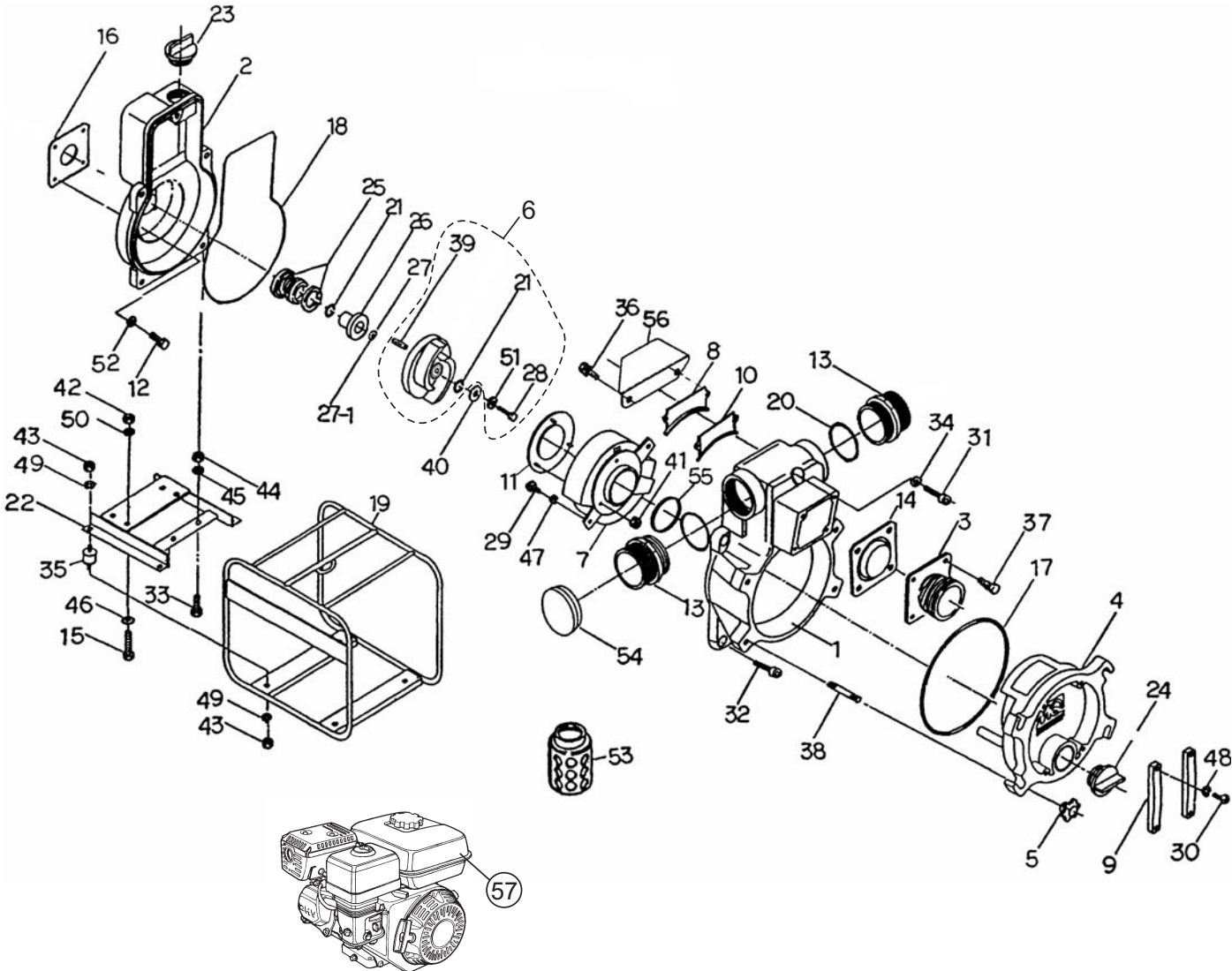

QP2TH — PUMP ASSY.

PUMP ASSY.

<u>NO.</u>	<u>PART NO.</u>	<u>PART NAME</u>	<u>QTY.</u>	<u>REMARKS</u>
38	0151191257	STUD BOLT, (DRAIN COVER HANDLE) M12 X 57 X15 X 22	4	
39#	0520030310	KEY, 4.7 X21 MM	1	REPLACES P/N 0520030413
40	43592012400011	IMPELLER WASHER, DIA. 35 X 9 MM T4.5	1	
41	0204490060	U-NUT, WEAR PLATE M6	3	
42	0205490080	NUT, ENGINE M8	4	
43	0205490100	NUT, CUSHION RUBBER M10	8	
44	0205490100	NUT, PUMP M10	2	
45	0451290100	SPRING WASHER, PUMP M10	2	
46	0401650080	WASHER, ENGINE M8	4	
47	0457290080	SPRING WASHER, (VOLUTE CASING) M8	2	
48	0451290080	SPRING WASHER, (DRAIN COVER SET M8	4	
49	0451290100	SPRING WASHER, (CUSHION RUBBER) M10	8	
50	0451290080	SPRING WASHER, (ENGINE) M8	4	
51#	0458220080	SPRING WASHER, (IMPELLER), M8	1	REPLACES P/N 0451290080
52	0451290080	SPRING WASHER, (CASING COVER) M8	4	
53	0742214050	STRAINER	1	
54	1889108050	CAP	1	
55	0481310700	O'RING	1	
56	1889250770	OVERFLOW SUPPRESSOR	1	
57	GX160K1QX2	ENGINE, HONDA 5.5 HP	1	S/N 2TH-3428 AND BELOW
57	GX160U1QX2	ENGINE, HONDA 5.5 HP	1	S/N 2TH-3429 AND ABOVE

HONDA GX160K1QX2/GX160U1QX2 ENGINES — AIR CLEANER ASSY.

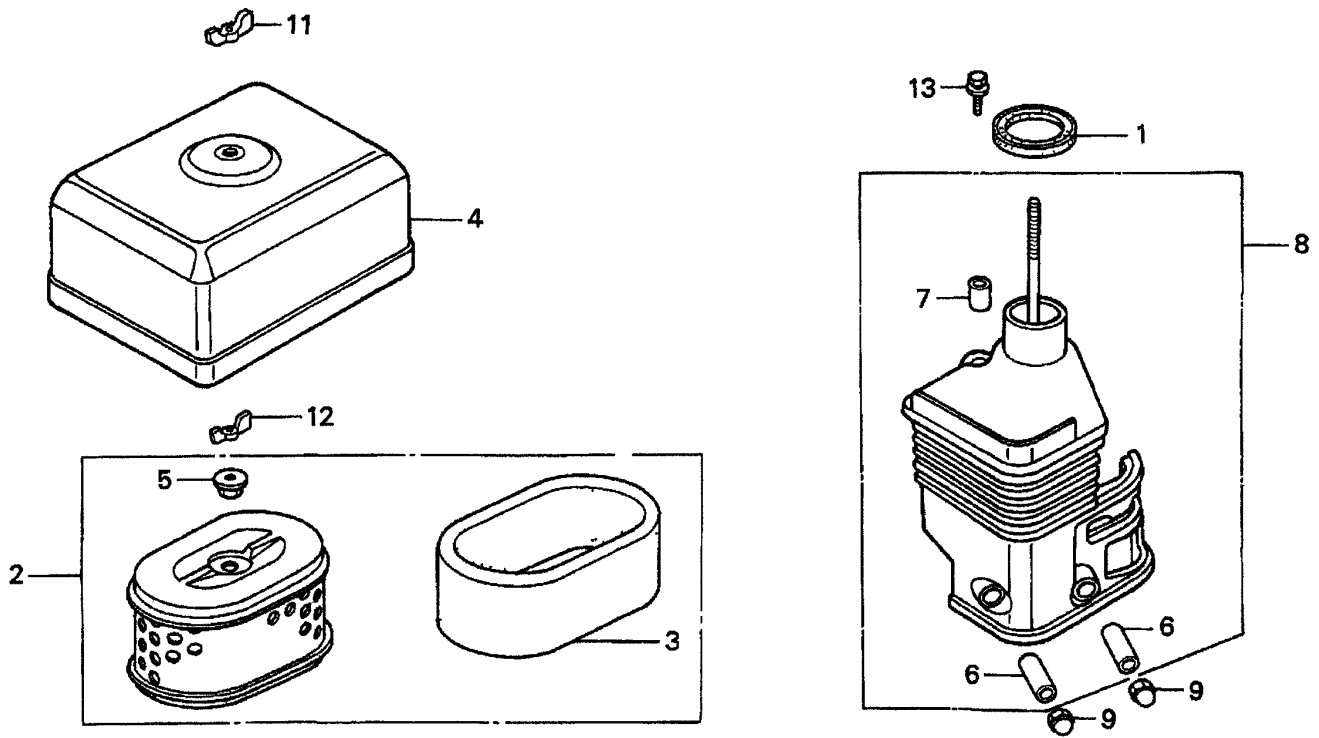

HONDA GX160K1QX2/GX160U1QX2 ENGINES — AIR CLEANER ASSY.

AIR CLEANER ASSY.

<u>NO.</u>	<u>PART NO.</u>	<u>PART NAME</u>	<u>QTY.</u>	<u>REMARKS</u>
1	16271ZE1000	GASKET, ELBOW	1	
2✖	17210ZE1505	ELEMENT, AIR CLEANER (DUAL).....	1.....	INCLUDES ITEMS W/#
2◇	17210ZE1822	ELEMENT, AIR CLEANER (DUAL).....	1.....	INCLUDES ITEMS W/%
3#%	17218ZE1821	FILTER, OUTER	1	
4	17230ZE1820	COVER, AIR CLEANER (DUAL)	1	
5#%	17232891000	GROMMET, AIR CLEANER	1	
6+	17238ZE7010	COLLAR, AIR CLEANER	2	
7+	17239ZE1000	COLLAR B, AIR CLEANER	1	
8	17410ZE1020	ELBOW, AIR CLEANER	1.....	INCLUDES ITEM W/+
9✖	90201415000	NUT, CAP 6MM	2	
9◇	9405006000	NUT, FLANGE 6MM	2	
11	90325044000	WINGNUT, TOOL BOX SETTING	1	
12	90325044000	WINGNUT, TOOL BOX SETTING	1	
13	957010602000	BOLT, FLANGE 6 X 20	1	

NOTICE

- ✖ GX160K1QX2: Model QP-2TH S/N 2TH-3428 AND BELOW
- ◇ GX160U1QX2: Model QP-2TH S/N 2TH-3429 AND ABOVE

HONDA GX160K1QX2/GX160U1QX2 ENGINES — CAMSHAFT ASSY.

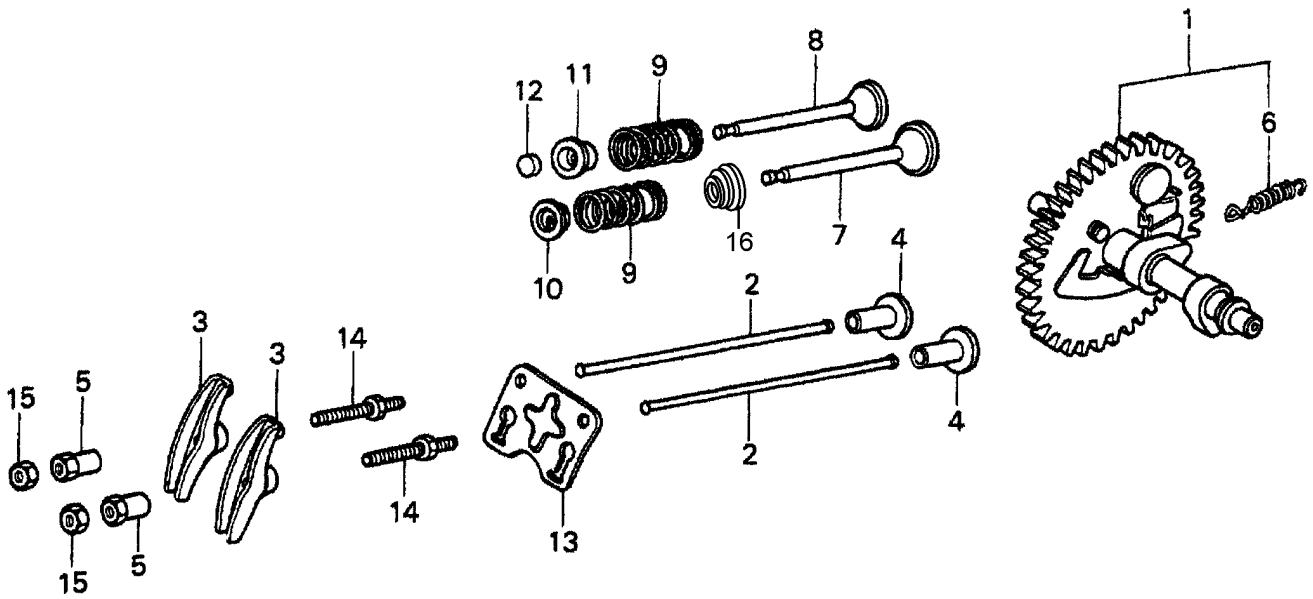

HONDA GX160K1QX2/GX160U1QX2 ENGINES — CAMSHAFT ASSY.

CAMSHAFT ASSY.

<u>NO.</u>	<u>PART NO.</u>	<u>PART NAME</u>	<u>QTY.</u>	<u>REMARKS</u>
1	14100ZE1812	CAMSHAFT ASSY.....	1.....	INCLUDES ITEMS W/@
2	14410ZE1010	ROD, PUSH	2	
3	14431ZE1000	ARM, VALVE ROCKER	2	
4	14441ZE1010	LIFTER, VALVE	2	
5	14451ZE1013	PIVOT, ROCKER ARM	2	
6@	14568ZE1000	SPRING, WEIGHT RETURN	1	
7	14711ZF1000	VALVE, INTAKE	1	
8	14721ZF1000	VALVE, EXHAUST	1	
9	14751ZF1000	SPRING VALVE	2	
10	14771ZE1000	RETAINER, INTAKE VALVE SPRING	1	
11	14773ZE1000	RETAINER, EXHAUST VALVE SPRING	1	
12	14781ZE1000	ROTATOR, VALVE	1	
13	14791ZE1010	PLATE, PUSH ROD GUIDE	1	
14	90012ZE0010	BOLT, PIVOT 8MM	2	
15	90206ZE1000	NUT, PIVOT ADJ.	2	
16◇	12209ZH8003	SEAL, VALVE STEM	1	

NOTICE

- ❖ GX160K1QX2: Model QP-2TH S/N 2TH-3428 AND BELOW
- ◇ GX160U1QX2: Model QP-2TH S/N 2TH-3429 AND ABOVE

HONDA GX160K1QX2/GX160U1QX2 ENGINES — CARBURETOR ASSY.

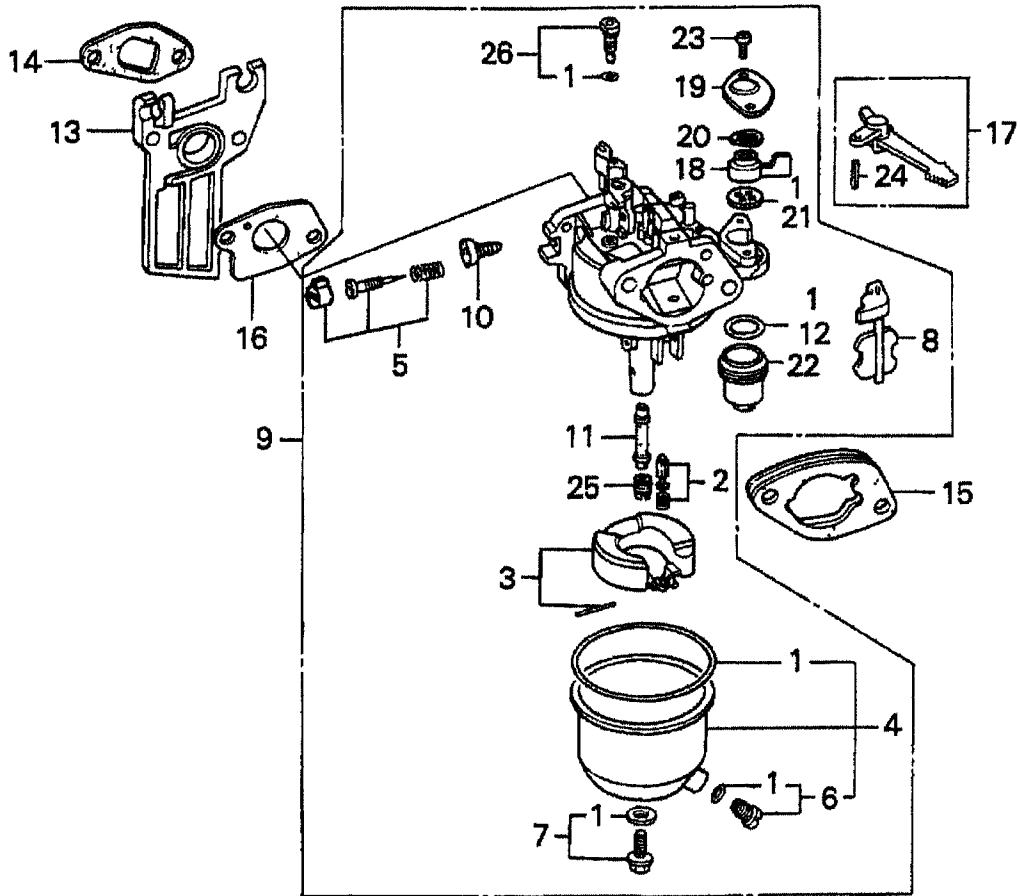

HONDA GX160K1QX2/GX160U1QX2 ENGINES — CARBURETOR ASSY.

CARBURETOR ASSY.

<u>NO.</u>	<u>PART NO.</u>	<u>PART NAME</u>	<u>QTY.</u>	<u>REMARKS</u>
1@#+%&	16010ZE1812	GASKET SET	1	
2@	16011ZE0005	VALVE SET, FLOAT	1	
3	16013ZE0005	FLOAT SET	1	
4@	16015ZE0831	CHAMBER SET, FLOAT	1.....	INCLUDES ITEMS/#
5@	16016ZH7W01	SCREW SET	1	
6@#	16024ZE1811	SCREW SET, DRAIN	1.....	INCLUDES ITEM W/+
7@	16028ZE0005	SCREW SET B.....	1.....	INCLUDES ITEM W/%
8@	16044ZE0005	CHOKE SET	1	
9	16100ZH8W51	CARBURETOR ASSEMBLY, BE65B B.....	1.....	INCLUDES ITEMS/@
10@	16124ZE0005	SCREW, THROTTLE STOP	1	
11@	16166ZH8W50	NOZZLE, MAIN	1	
12@	16173001004	O- RING	1	
13	16211ZE1000	INSULATOR, CARBURETOR	1	
14	16212ZH8800	GASKET, INSULATOR	1	
15	16220ZE1020	SPACER, CARBURETOR	1	
16	16221ZH8801	GASKET, CARBURETOR	1	
17	16610ZE1000	LEVER, CHOKE STANDARD.....	1.....	INCLUDES ITEM W/\$
18@	16953ZE1812	LEVER, VALVE	1	
19	16954ZE1812	PLATE, LEVER SETTING	1	
20@	16956ZE1811	SPRING, VALVE LEVER	1	
21@	16957ZE1812	GASKET, VALVE	1	
22@	16967ZE0811	CUP, FUEL STRAINER	1	
23x@	93500030060H	SCREW, PAN 3 X 6	2	
23◇@	93500030061H	SCREW, PAN 3 X 6	2	
24\$	9430520122	PIN, SPRING 2 X 12	1	
25x@	99101ZH80650	JET, MAIN #65 (OPTIONAL)	1	
25x@	99101ZH80680	JET, MAIN #68 (OPTIONAL)	1	
25◇@	99101ZH80700	JET, MAIN #70 (OPTIONAL)	1	
26@	99204ZE00350	JET SET, PILOT #35	1.....	INCLUDES ITEMS W/&

NOTICE

- x GX160K1QX2: Model QP-2TH S/N 2TH-3428 AND BELOW
- ◇ GX160U1QX2: Model QP-2TH S/N 2TH-3429 AND ABOVE

HONDA GX160K1QX2/GX160U1QX2 ENGINES — CONTROL ASSY.

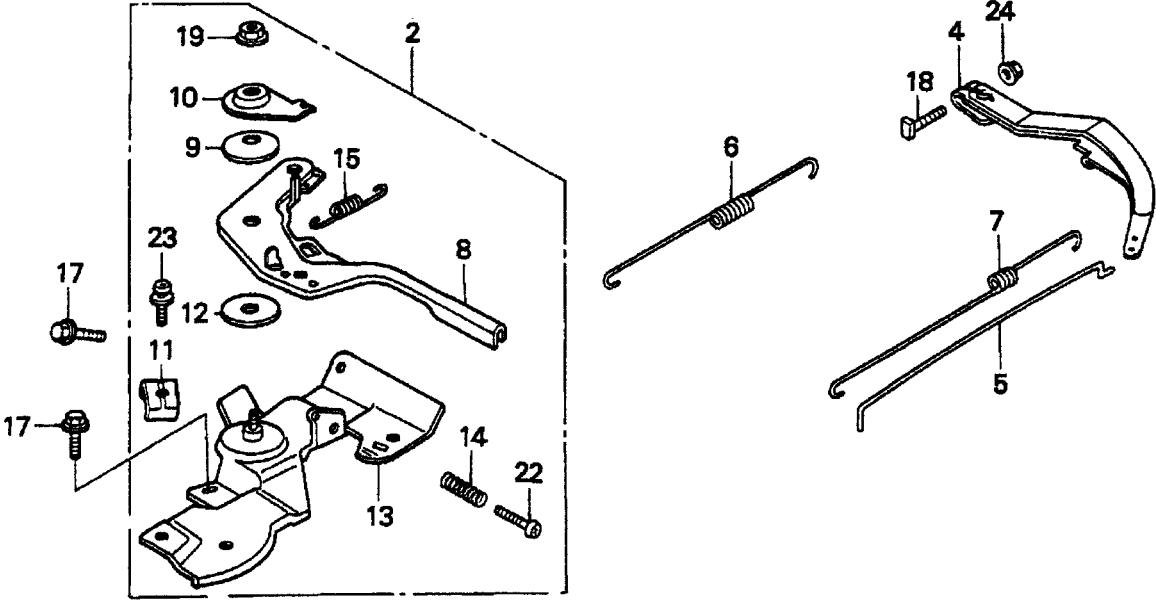

HONDA GX160K1QX2/GX160U1QX2 ENGINES — CONTROL ASSY.

CONTROL ASSY.

<u>NO.</u>	<u>PART NO.</u>	<u>PART NAME</u>	<u>QTY.</u>	<u>REMARKS</u>
2	16500ZH8823	CONTROL ASSEMBLY, REMOTE	1.....	INCLUDES ITEMS W/@
4	16551ZE0010	ARM, GOVERNOR	1	
5	16555ZE1000	ROD, GOVERNOR	1	
6	16561ZE1020	SPRING GOVERNOR	1	
7	16562ZE1020	SPRING, THROTTLE RETURN	1	
8@	16571ZH8020	LEVER, CONTROL	1	
9@	16574ZE1000	SPRING, LEVR	1	
10@	16575ZH8000	WASHER, CONTROL LEVER	1	
11@	16576891000	HOLDER, CABLE	1	
12@	16578ZE1000	SPACER, CONTROL LEVER	1	
13x@	16580ZH8812	BASE, CONTROL (REMOTE)	1	
13◇@	16580ZH8813	BASE, CONTROL (REMOTE)	1	
14@	16584883300	SPRING, CONTROL ADJUSTING	1	
15@	16592ZE1810	SPRING, CABLE RETURN	1	
17	90013883000	BOLT, FLANGE 6 X 12 (CT200)	2	
18x	90016ZE5010	BOLT, GOVERNOR ARM	1	
18◇	90015ZE5010	BOLT, GOVERNOR ARM	1	
19@	90114SA0000	NUT, SELF- LOCK 6MM	1	
22@	93500050250H	SCREW, PAN 5 X 25	1	
23x@	938930501600	SCREW, WASHER 5 X 16	1	
23◇@	93500050160A	SCREW, WASHER 5 X 16	1	
24	9405006000	NUT, FLANGE 6MM	1	

NOTICE

- x GX160K1QX2: Model QP-2TH S/N 2TH-3428 AND BELOW
- ◇ GX160U1QX2: Model QP-2TH S/N 2TH-3429 AND ABOVE

HONDA GX160K1QX2/GX160U1QX2 ENG. — CRANKCASE COVER ASSY.

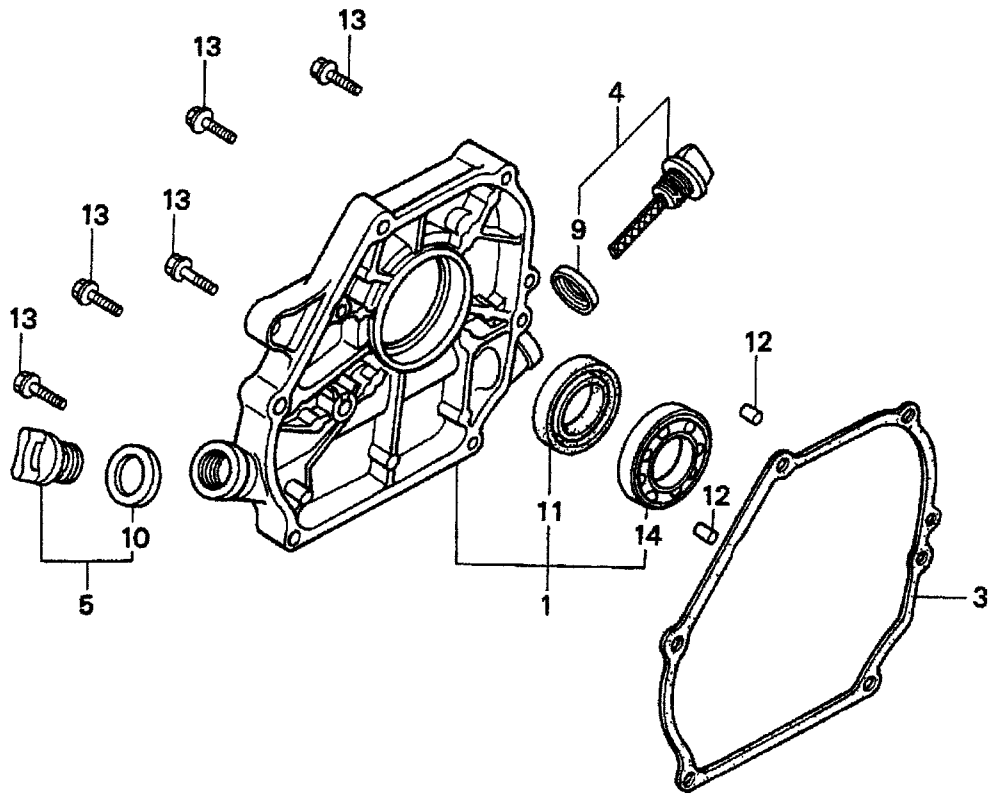

HONDA GX160K1QX2/GX160U1QX2 ENG. — CRANKCASE COVER ASSY.

CRANKCASE COVER ASSY.

<u>NO.</u>	<u>PART NO.</u>	<u>PART NAME</u>	<u>QTY.</u>	<u>REMARKS</u>
1✖	11300ZE1641	COVER ASSEMBLY, CRANKCASE (U- TYPE)	1	INCLUDES ITEMS W/@
1◇	11300ZE1642	COVER ASSEMBLY, CRANKCASE (U- TYPE)	1	INCLUDES ITEMS W/@
3	11381ZH8801	GASKET, CASE COVER (NON- ASBESTOS)	1	
4	15600ZE1003	CAP ASSEMBLY, OIL FILLER	1	INCLUDES ITEMS W/#
5	15600ZG4003	CAP ASSEMBLY, OIL FILLER	1	INCLUDES ITEMS W/+
9#	15625ZE1003	GASKET, OIL FILLER CAP	1	
10+	15625ZE1003	GASKET, OIL FILLER CAP	1	
11✖@	91202883005	OIL SEAL 25 X 41 X 6	1	
11◇@	91201Z0T801	OIL SEAL 25 X 41 X 6	1	
12	9430108140	PIN A, DOWEL 8 X 14	2	
13	957010803200	BOLT, FLANGE 8 X 32	6	
14@	961006205000	BEARING, RADIAL BALL 6205	1	

NOTICE

- ✖ GX160K1QX2: Model QP-2TH S/N 2TH-3428 AND BELOW
- ◇ GX160U1QX2: Model QP-2TH S/N 2TH-3429 AND ABOVE

HONDA GX160K1QX2/GX160U1QX2 ENGINES — CRANKSHAFT ASSY.

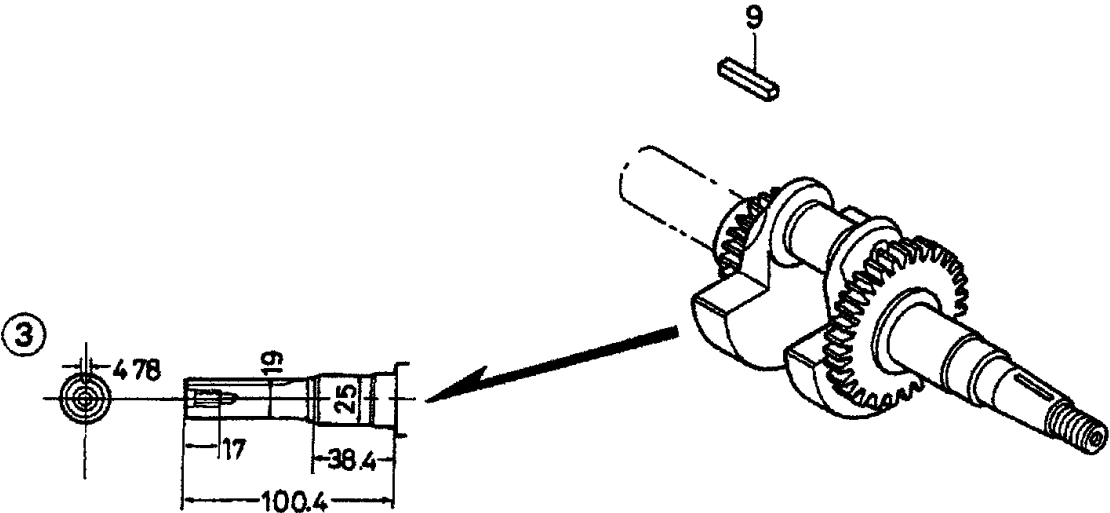

HONDA GX160K1QX2/GX160U1QX2 ENGINES — CRANKSHAFT ASSY.

CRANKSHAFT ASSY.

<u>NO.</u>	<u>PART NO.</u>	<u>PART NAME</u>	<u>QTY.</u>	<u>REMARKS</u>
3	13310ZE1601	CRANKSHAFT, Q- TYPE	1	
9	90745ZE1600	KEY, 4.78 X 4,78 X 38	1	

HONDA GX160K1QX2/GX160U1QX2 ENG. — CYLINDER BARREL ASSY.

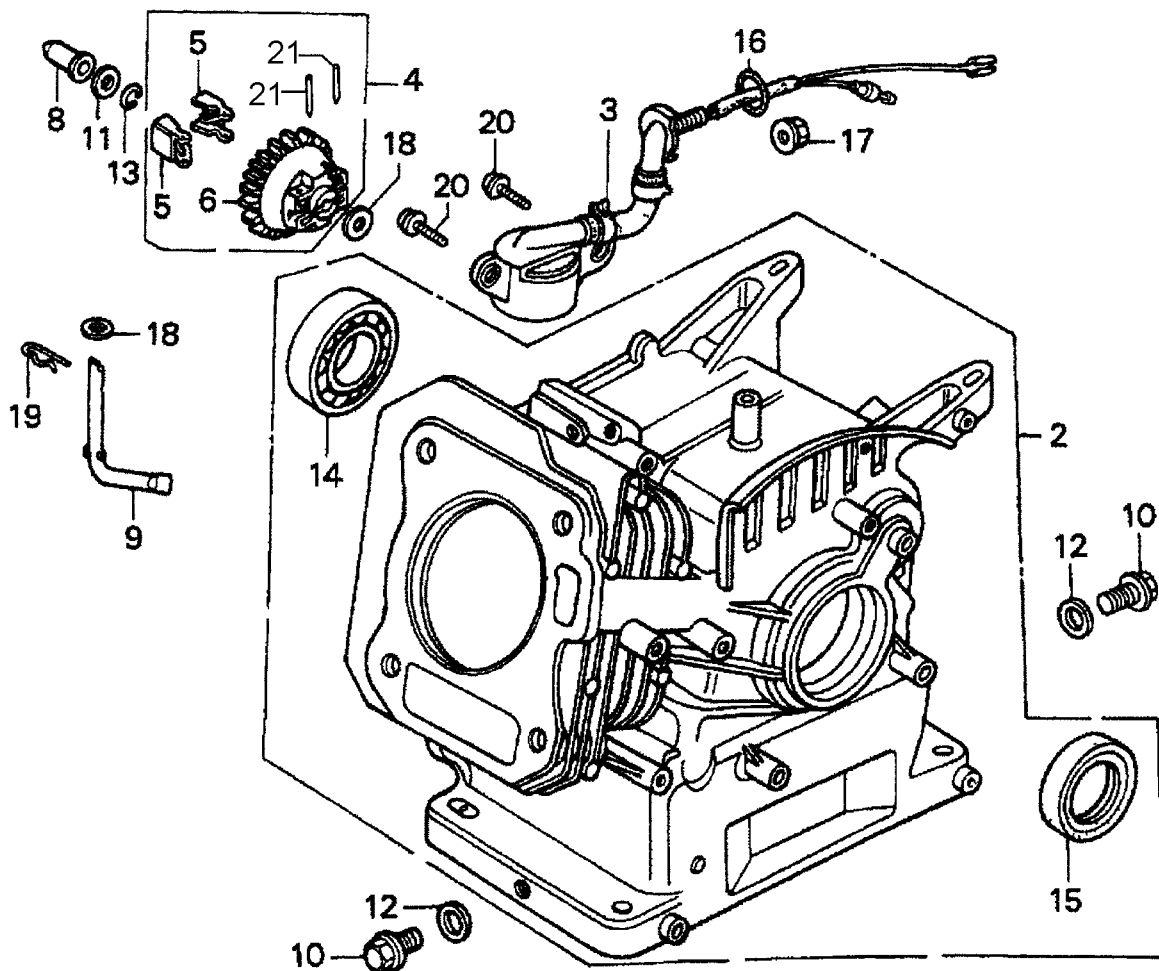

HONDA GX160K1QX2/GX160U1QX2 ENG. — CYLINDER BARREL ASSY.

CYLINDER BARREL ASSY.

<u>NO.</u>	<u>PART NO.</u>	<u>PART NAME</u>	<u>QTY.</u>	<u>REMARKS</u>
2	12000ZH8811	CYLINDER ASSEMBLY, OIL ALERT	1.....	INCLUDES ITEMS W/@
3	15510ZE1033	SWITCH ASSEMBLY, OIL LEVEL	1	
4	16510ZE1000	GOVERNOR ASSEMBLY	1.....	INCLUDES ITEMS W/#
5#	16511ZE1000	WEIGHT, GOVERNOR	2	
6#	16512ZE1000	HOLDER, GOVERNOR WEIGHT	1	
8	16531ZE1000	SLIDER, GOVERNOR	1	
9	16541ZE1000	SHAFT, GOVERNOR ARM	1	
10	90131ZE1000	BOLT, DRAIN PLUG	2	
11	80451ZE1000	WASHER, THRUST 6MM	1	
12	90601ZE1000	WASHER, DRAIN PLUG 10.2MM	2	
13	90602ZE1000	CLIP, GOVERNOR HOLDER	1	
14x@	91001ZF1003	BEARING, RADIAL BALL 6205	1	
14◇@	91001ZF1004	BEARING, RADIAL BALL 6205SH, KOYO	1	
15x@	91202883005	OIL SEAL 25 X 41 X 6	1	
15◇@	91201Z0T801	OIL SEAL 25 X 41 X 6	1	
16x	91353671003	O- RING 13.5 X 1.5 (ARAI)	1	
16◇	91353671004	O- RING 14MM (NOK)	1	
17	9405010000	NUT, FLANGE 10MM	1	
18	9410106800	WASHER, PLAIN 6MM	2	
19	9425108000	PIN, LOCK 8MM	1	
20	957010601200	BOLT, FLANGE 6 X 12	2	
21◇#	16513ZE1000	GOVERNOR WEIGHT PIN	2	

NOTICE

- x GX160K1QX2: Model QP-2TH S/N 2TH-3428 AND BELOW
- ◇ GX160U1QX2: Model QP-2TH S/N 2TH-3429 AND ABOVE

HONDA GX160K1QX2/GX160U1QX2 ENGINES — CYLINDER HEAD ASSY.

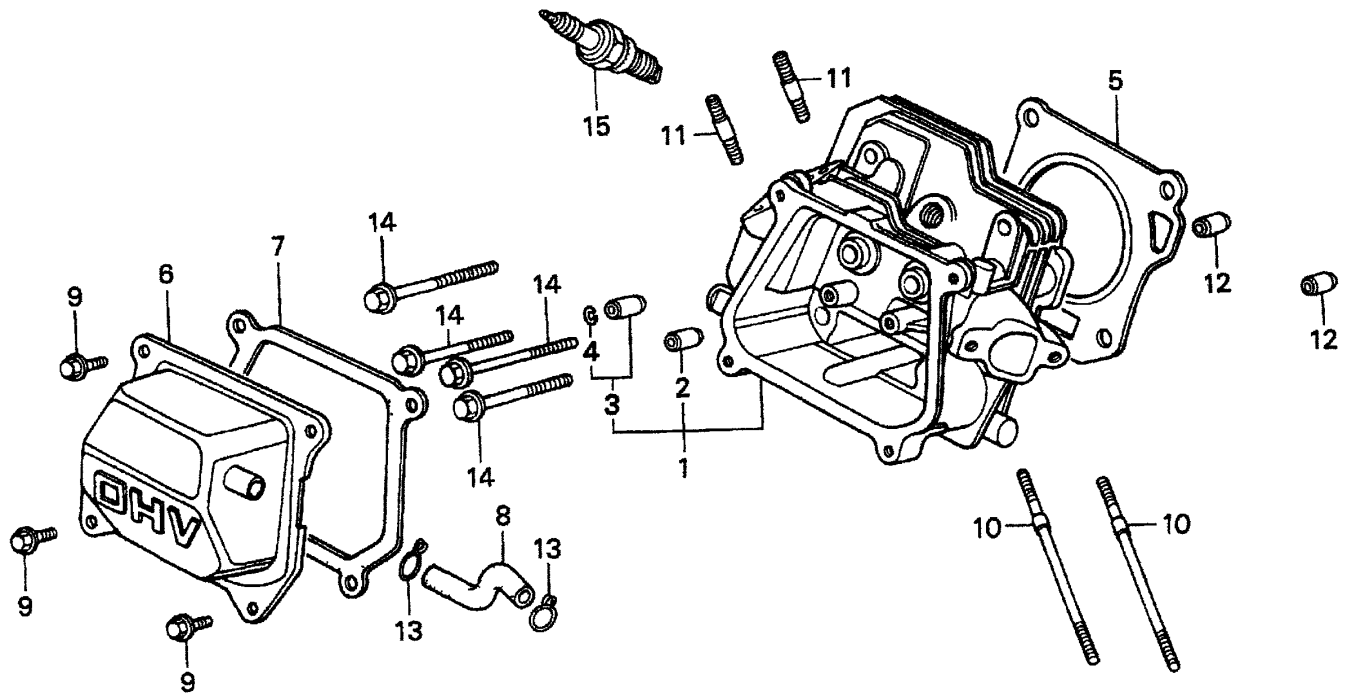

HONDA GX160K1QX2/GX160U1QX2 ENGINES — CYLINDER HEAD ASSY.

CYLINDER HEAD ASSY.

<u>NO.</u>	<u>PART NO.</u>	<u>PART NAME</u>	<u>QTY.</u>	<u>REMARKS</u>
1✖	12210ZH8000	CYLINDER HEAD.....	1.....	INCLUDES ITEMS W/@
1◇	12210ZH8405	CYLINDER HEAD.....	1.....	INCLUDES ITEMS W/@
2@	12204ZE1306	GUIDE, VALVE OS (OPTIONAL	1	
3@	12205ZE1315	GUIDE, EXHAUST VALVE OS (OPTIONAL)	1.....	INCLUDES ITEM W/%
4%	12216ZE5300	CLIP, VALVE GUIDE	1	
5	12251ZF1800	GASKET, CYLINDER HEAD	1	
6✖	12310ZE1010	COVER, HEAD	1	
6◇	12310ZE1020	COVER, HEAD	1	
7	12391ZE1000	GASKET, CYLINDER HEAD COVER	1	
8	15721ZH8000	TUBE, BREATHER	1	
9✖	90016ZE1000	BOLT, FLANGE 6 X13	4	
9◇	900138830010	BOLT, FLANGE 6 X12, CT200	4	
10	90043ZE1020	BOLT, STUD 6 X109	2	
11	90047ZE1000	BOLT, STUD 8 X 32	2	
12	9430110160	PIN A, DOWEL 10 X16	2	
14	957230806000	BOLT, FLANGE 8 X60	4	
15	9807956846	SPARK PLUG BPR6ES (NGK)	1	
15◇	9807956855	SPARK PLUG W20EPR-U (DENSO)	1	
15◇	9807955846	SPARK PLUG BPR5ES (NGK)	1	
15◇	9807955855	SPARK PLUG W16EPR-U (DENSO)	1	

NOTICE

- ✖ GX160K1QX2: Model QP-2TH S/N 2TH-3428 AND BELOW
- ◇ GX160U1QX2: Model QP-2TH S/N 2TH-3429 AND ABOVE

HONDA GX160K1QX2/GX160U1QX2 ENGINES — FAN COVER ASSY.

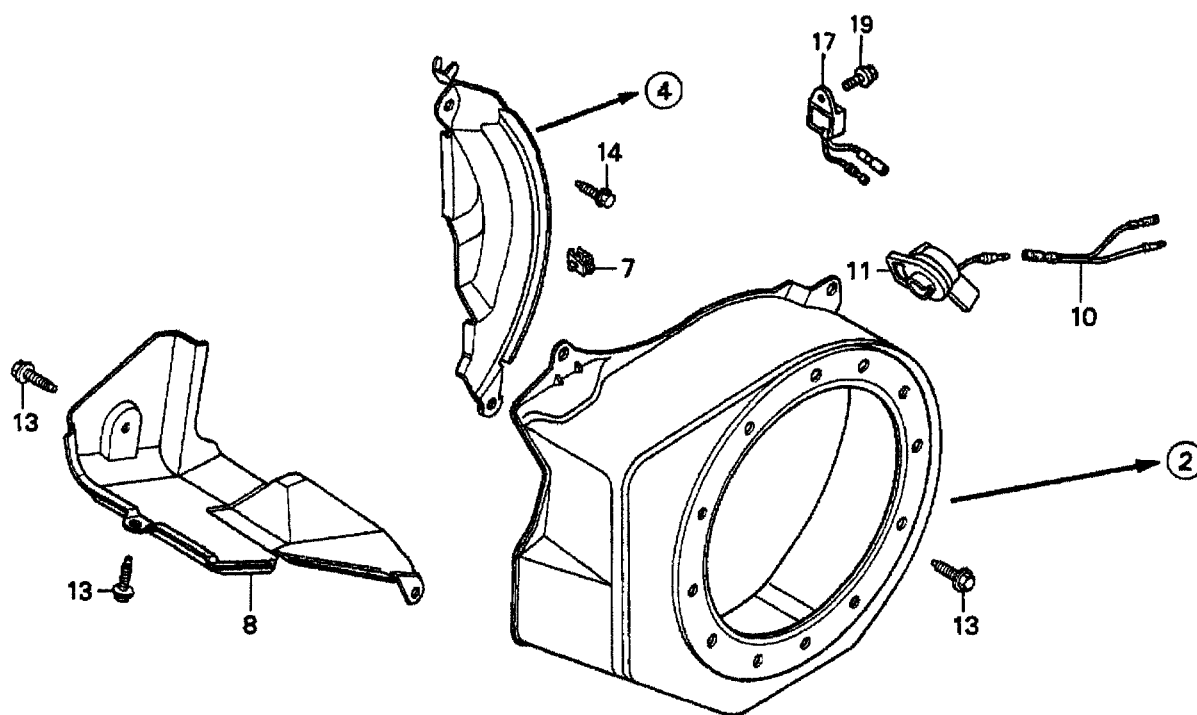

HONDA GX160K1QX2/GX160U1QX2 ENGINES — FAN COVER ASSY.

FAN COVER ASSY.

<u>NO.</u>	<u>PART NO.</u>	<u>PART NAME</u>	<u>QTY.</u>	<u>REMARKS</u>
2	19610ZE1000ZC	COVER, FAN "NH1" (BLACK)	1	
2◇	19610ZE1000ZP	COVER, FAN *R280*	1	
4	19611ZH8810	PLATE, SIDE (OIL ALERT)	1	
7	90601ZH7013	CLIP, HARNESS	1	
8	19630ZH8000	SHROUD	1	
10	32197ZH8003	SUB- HARNESS	1	
11❖	36100ZE1015	SWITCH ASSEMBLY, ENGINE STOP	1	
11◇	36100ZF6P81	SWITCH ASSEMBLY, ENGINE STOP	1	
13	90013883000	BOLT, FLANGE 6 X12 (CT200)	6	
14	90022888010	BOLT, FLANGE 6 X20 (CT200)	1	
17	34150ZH7003	ALERT UNIT, OIL	1	
19	957010600800	BOLT, FLANGE 6 X8	1	

NOTICE

- ❖ GX160K1QX2: Model QP-2TH S/N 2TH-3428 AND BELOW
- ◇ GX160U1QX2: Model QP-2TH S/N 2TH-3429 AND ABOVE

HONDA GX160K1QX2/GX160U1QX2 ENGINES — FLYWHEEL ASSY.

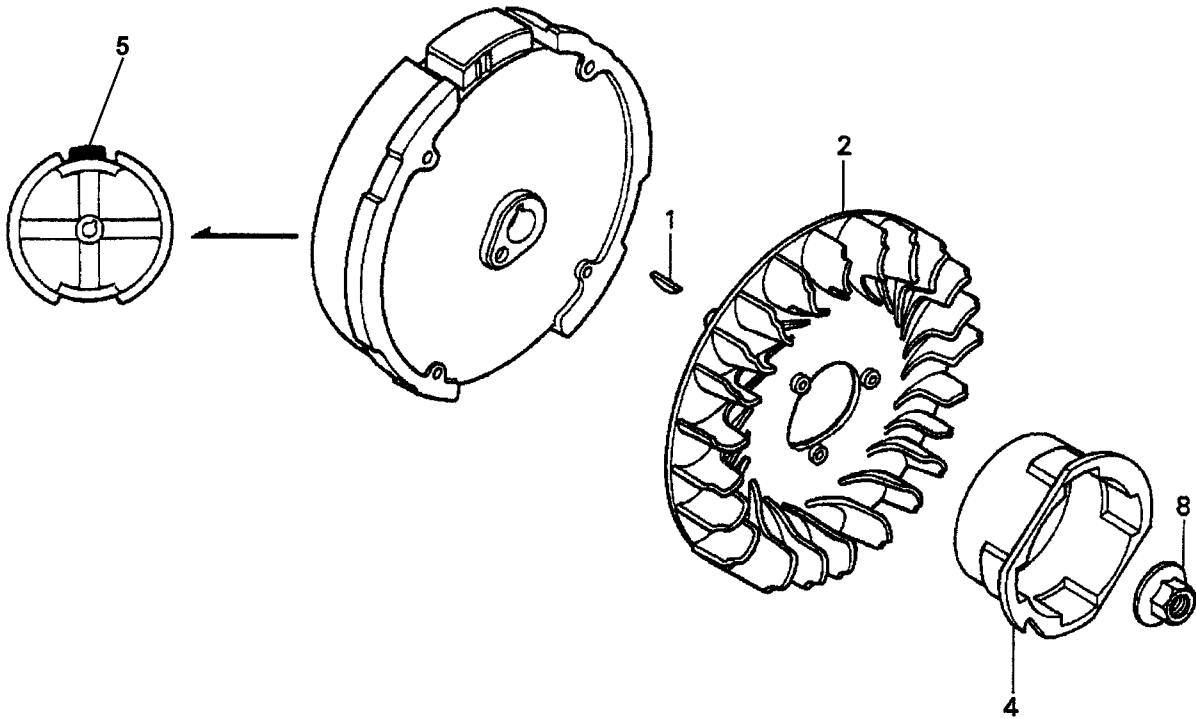

HONDA GX160K1QX2/GX160U1QX2 ENGINES — FLYWHEEL ASSY.

FLYWHEEL ASSY.

<u>NO.</u>	<u>PART NO.</u>	<u>PART NAME</u>	<u>QTY.</u>	<u>REMARKS</u>
1	13331357000	KEY, SPECIAL WOODRUFF (25 X18)	1	
2	19511ZE1000	FAN, COOLING	1	
4❖	28451ZH8003	PULLEY, STARTER	1	
4◇	28451ZH8801	PULLEY, STARTER	1	
5	31100ZE1010	FLYWHEEL	1	
5❖	31100ZE1810	FLYWHEEL, LAMP	1	
8	90201878003	NUT, SPECIAL 14MM	1	

NOTICE

- ❖ GX160K1QX2: Model QP-2TH S/N 2TH-3428 AND BELOW
- ◇ GX160U1QX2: Model QP-2TH S/N 2TH-3429 AND ABOVE

HONDA GX160K1QX2/GX160U1QX2 ENGINES — FUEL TANK ASSY.

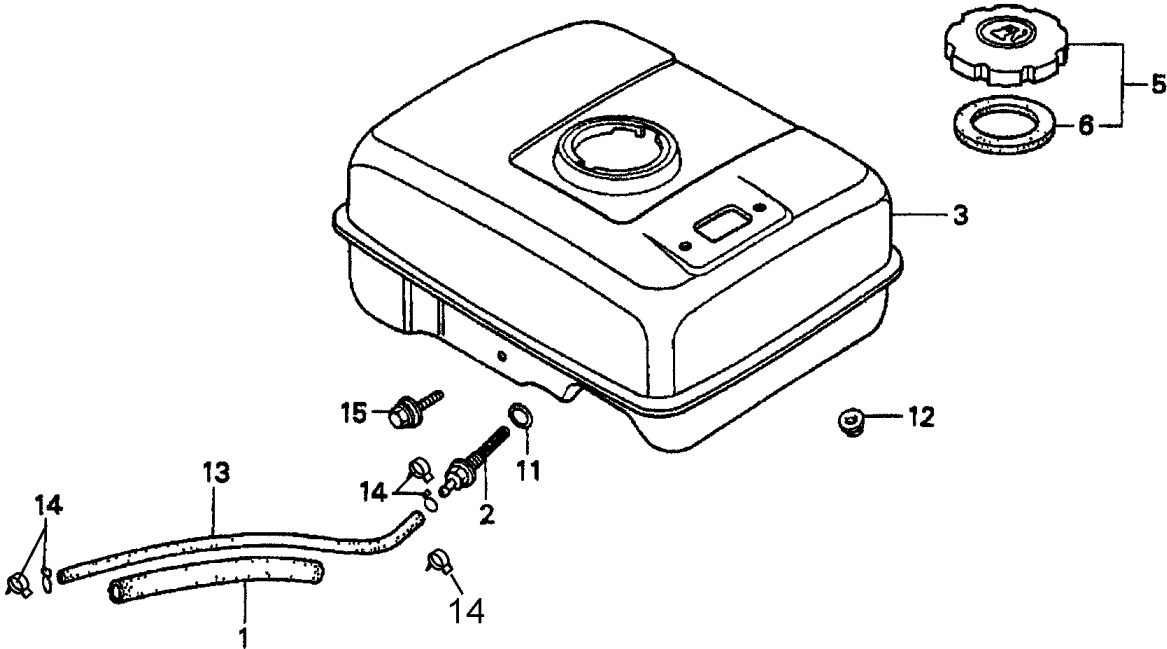

HONDA GX160K1QX2/GX160U1QX2 ENGINES — FUEL TANK ASSY.

FUEL TANK ASSY.

<u>NO.</u>	<u>PART NO.</u>	<u>PART NAME</u>	<u>QTY.</u>	<u>REMARKS</u>
1	16854ZH8000	RUBBER, SUPPORTER 107MM	1	
2	16955ZE1000	JOINT, FUEL TANK	1	
3	17510ZE1020ZA	TANK, FUEL *NH31*	1	
3	17510ZE1020ZF	TANK, FUEL *NH1* (BLACK)	1	
5✖	17620ZH7023	CAP, FUEL FILLER.....	1.....	INCLUDES ITEM W/@
5◇	17620ZH7305	CAP, FUEL FILLER CHROME PLATED.....	1.....	INCLUDES ITEM W/@
6✖@	17631ZH7003	GASKET, FUEL FILLER CAP	1	
6◇@	17631ZOT812	GASKET, FUEL FILLER CAP 39X62X3	1	
11✖	91353671003	O- RING 13.5 X1.5 (ARAI)	1	
11◇	91353671004	O- RING 14 (NOK)	1	
12	9405006000	NUT, FLANGE 6MM	2	
13✖	950014500360M	BULK HOSE, FUEL 4.5 X 3000 (4.5 X 140)	1	
13◇	91424Z4F801	BULK HOSE, FUEL 4.5 X 140 (FKM.....)	1.....	S/N 1031487 AND BELOW
13◇	950014514040	BULK HOSE, FUEL 4.5 X 140.....	1.....	S/N 1031488 AND ABOVE
			REPLACES 950014500160M
14✖	9500202080	CLIP, TUBE B8	2	
14◇	9500202080	CLIP, TUBE B8.....	2.....	S/N 1031487 AND BELOW
14◇	950024080008	CLAMP, TUBE D8.....	2.....	S/N 1031488 AND ABOVE
15✖	957010602500	BOLT, FLANGE 6 X 25	1	
15◇	90004ZH7003	BOLT, FLANGE 6 X 29	1	

NOTICE

- ✖ GX160K1QX2: Model QP-2TH S/N 2TH-3428 AND BELOW
- ◇ GX160U1QX2: Model QP-2TH S/N 2TH-3429 AND ABOVE

HONDA GX160K1QX2/GX160U1QX2 ENGINES — IGNITION COIL ASSY.

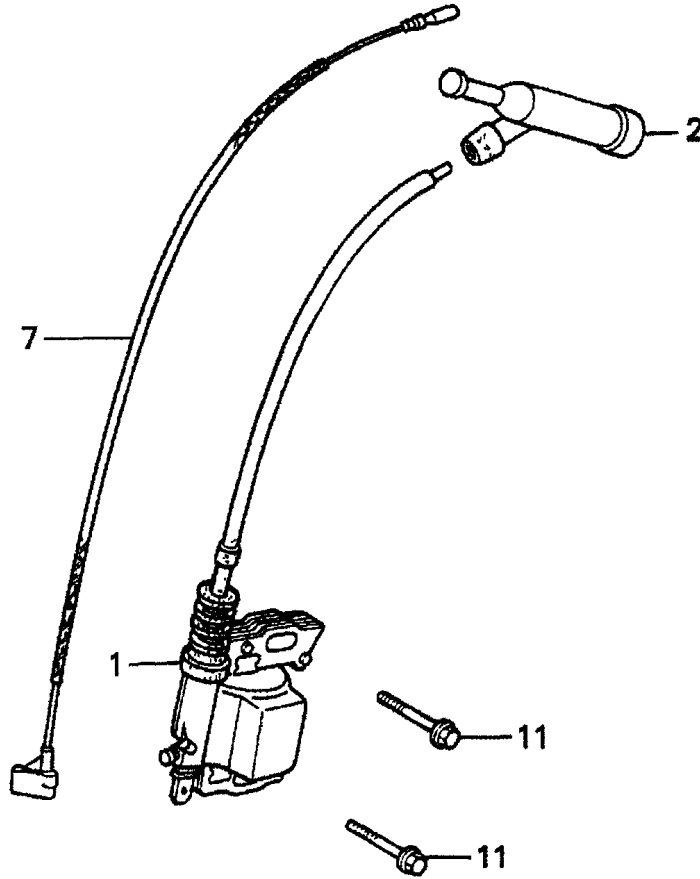

HONDA GX160K1QX2/GX160U1QX2 ENGINES — IGNITION COIL ASSY.

IGNITION COIL ASSY.

<u>NO.</u>	<u>PART NO.</u>	<u>PART NAME</u>	<u>QTY.</u>	<u>REMARKS</u>
1✖	30500ZE1033	COIL ASSEMBLY, IGNITION	1	
1◇	30500ZE1063	COIL ASSEMBLY, IGNITION	1	
2	30700ZE1013	CAP ASSEMBLY, NOISE SUPPRESSOR	1	
7	36101ZE1010	WIRE, STOP SWITCH 370MM	1	
11	90121952000	BOLT, FLANGE 6 X25	2	

NOTICE

- ✖ GX160K1QX2: Model QP-2TH S/N 2TH-3428 AND BELOW
- ◇ GX160U1QX2: Model QP-2TH S/N 2TH-3429 AND ABOVE

HONDA GX160K1QX2/GX160U1QX2 ENG. — MUFFLER ASSY.

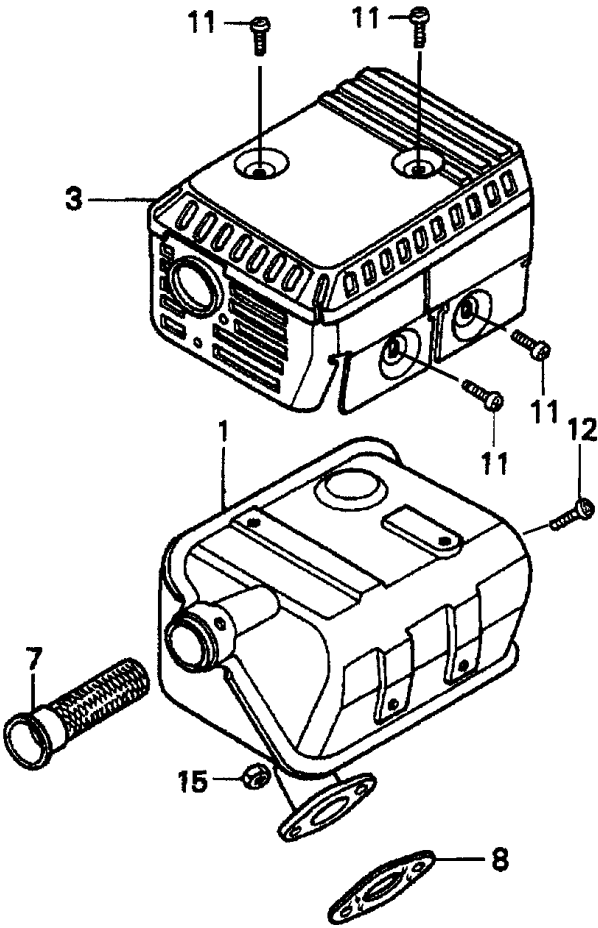

HONDA GX160K1QX2/GX160U1QX2 ENG. — MUFFLER ASSY.

MUFFLER ASSY.

<u>NO.</u>	<u>PART NO.</u>	<u>PART NAME</u>	<u>QTY.</u>	<u>REMARKS</u>
1	18310ZF1000	MUFFLER	1	
1	18310ZH8810	MUFFLER (OPTIONAL)	1	
3	18320ZF1H01	PROTECTOR, MUFFLER	1	
7	18355ZE1000	ARRESTER, SPARK (OPTIONAL)	1	
8	18381ZH8800	GASKET, MUFFLER	1	
11	90050ZE1000	SCREW, TAPPING 5 X 8 (OPTIONAL)	4	
12	90055ZE1000	SCREW, TAPPING 4 X 6 (OPTIONAL)	1	
15	94001080000S	NUT, HEX. 8MM	2	

HONDA GX160K1QX2/GX160U1QX2 ENG. — PISTON ASSY.

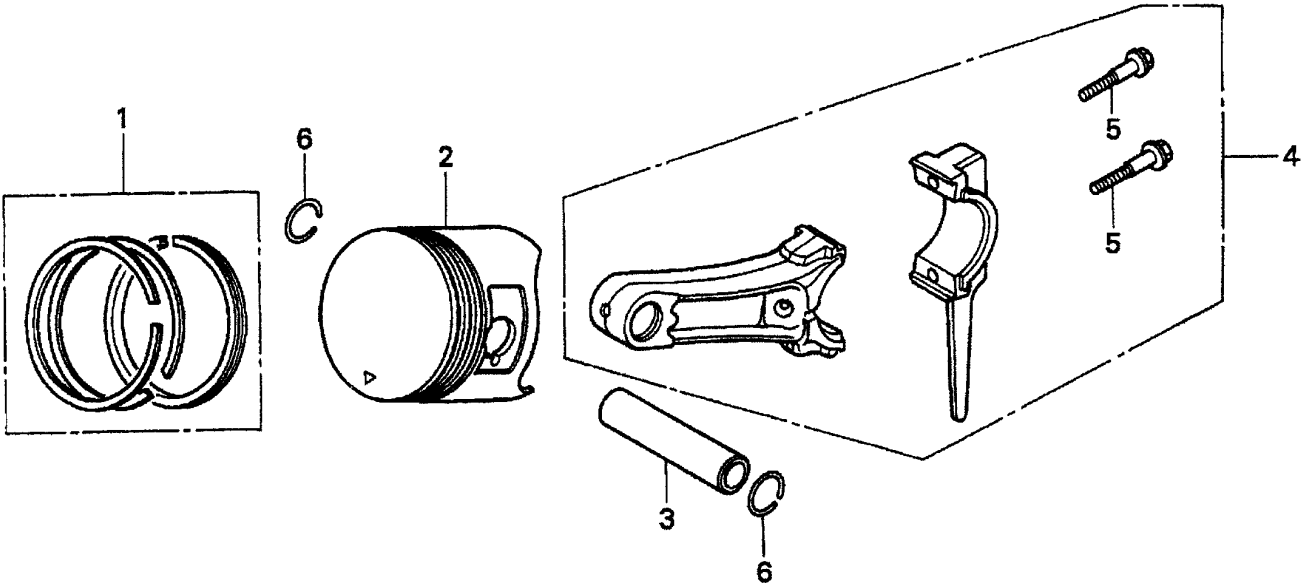

HONDA GX160K1QX2/GX160U1QX2 ENG. — PISTON ASSY.

PISTON ASSY.

<u>NO.</u>	<u>PART NO.</u>	<u>PART NAME</u>	<u>QTY.</u>	<u>REMARKS</u>
1✖	13010ZH8941	RING SET, PISTON (STD.)	1	
1◇	13310ZL0003	RING SET, PISTON (STD.)TEIKOKU	1	
1✖	13011ZH8941	RING SET, PISTON (OS 0.25), OP.	1	
1◇	13011ZL0003	RING SET, PISTON (OS 0.25), OP.TEIKOKU	1	
1✖	13012ZH8941	RING SET, PISTON (OS 0.50), OP.	1	
1◇	13012ZL0003	RING SET, PISTON (OS 0.50), OP.TEIKOKU	1	
1✖	13013ZH8941	RING SET, PISTON (0.75), OP.	1	
1◇	13013ZL0003	RING SET, PISTON (0.75), OP.TEIKOKU	1	
2✖	13101ZH8000	PISTON (STD.)	1	
2◇	13101ZH8010	PISTON (STD.)	1	
2✖	13102ZH8000	PISTON (OS 0.25), OP.	1	
2◇	13102ZH8010	PISTON (OS 0.25), OP.	1	
2✖	13103ZH8000	PISTON (OS 0.50), OP.	1	
2◇	13103ZH8010	PISTON (OS 0.50), OP.	1	
2✖	13104ZH8000	PISTON (0.75), OP.	1	
2◇	13104ZH8010	PISTON (OS 0.75), OP.	1	
3✖	13111ZE1000	PIN, PISTON	1	
3◇	13111ZE1000	PIN, PISTON	1	
4	132AOZE100	ROD ASSY., CONNECTING (US 0.25), OPT.	1	
4	13200ZE1010	ROD ASSEMBLY, CONNECTING	1	
5	90001ZE1000	BOLT, CONNECTING ROD	2	
6	90551ZE1000	CLIP, PISTON PIN 18MM	2	

NOTICE

- ✖ GX160K1QX2: Model QP-2TH S/N 2TH-3428 AND BELOW
- ◇ GX160U1QX2: Model QP-2TH S/N 2TH-3429 AND ABOVE

HONDA GX160K1QX2/GX160U1QX2 ENG. — RECOIL STARTER ASSY.

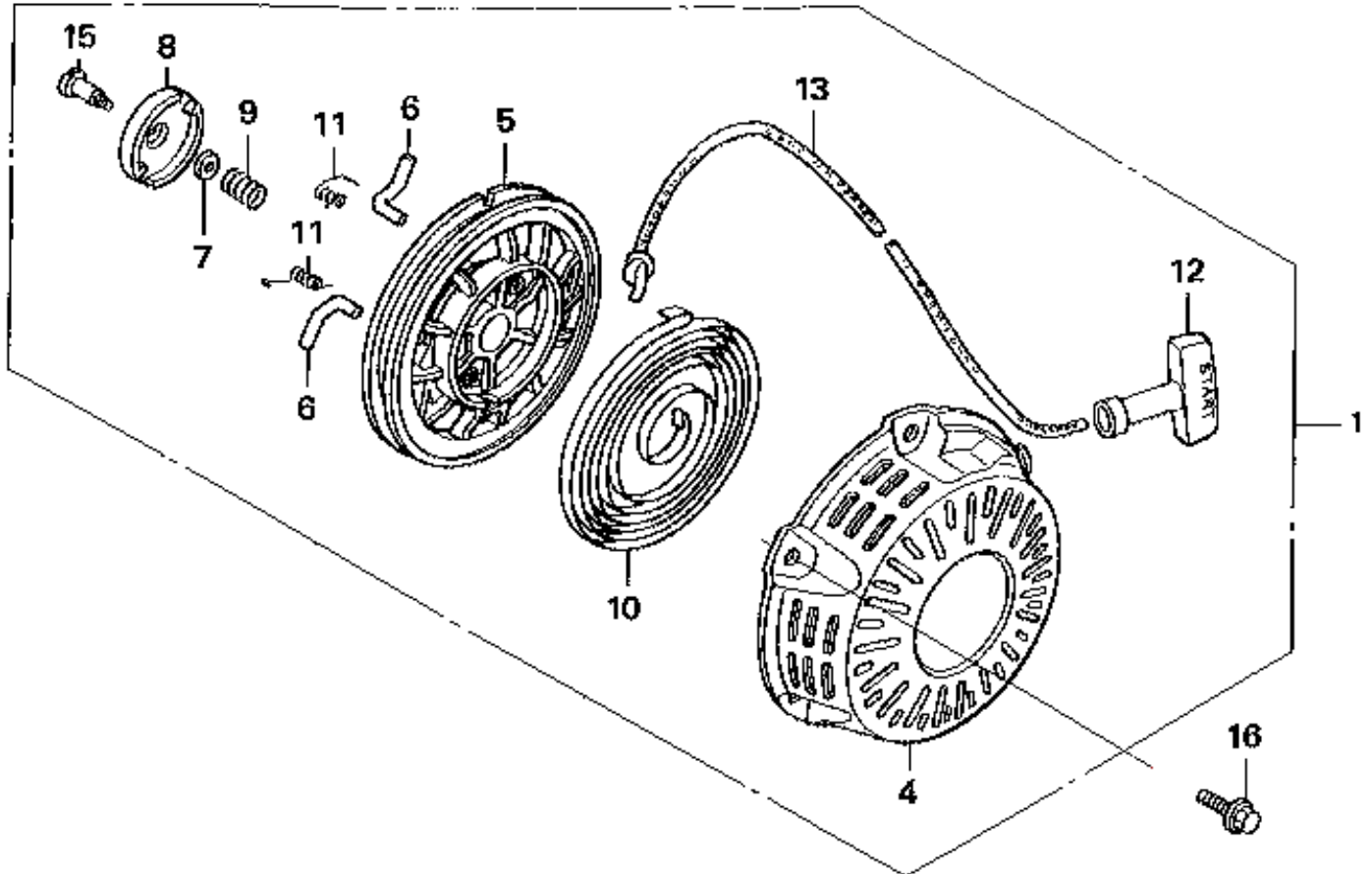

HONDA GX160K1QX2/GX160U1QX2 ENG. — RECOIL STARTER ASSY.

RECOIL STARTER ASSY.

<u>NO.</u>	<u>PART NO.</u>	<u>PART NAME</u>	<u>QTY.</u>	<u>REMARKS</u>
1	28400ZH8023YA	STARTER ASSY., RECOIL "R280"	1.....	INCLUDES ITEM W/@
1	28400ZH8023ZB	STARTER ASSY., RECOIL "NH1" BLACK	1.....	INCLUDES ITEM W/%
4@%	28410ZH8003YA	CASE, RECOIL STARTER "280"	1	
4@%	28410ZH8003ZB	CASE, RECOIL STARTER "NH1" BLACK	1	
5x@	28420ZH8013	REEL, RECOIL STARTER	1	
5◇@%	28421ZH8801	REEL, RECOIL STARTER	1	
6x@	28422ZH8013	RATCHET, STARTER	2	
6◇@%	28422ZH8801	RATCHET, STARTER	2	
7x@	28441ZH8003	PLATE, FRICTION	1	
7◇%	28431ZH8801	PLATE, FRICTION	1	
8x@	28433ZH8003	GUIDE, RATCHET	1	
8◇@%	28433ZH8801	GUIDE, RATCHET	1	
9◇%	28441ZH8801	SPRING, FRICTION	1	
10@%	28442ZH8003	SPRING, RECOIL STARTER	1	
11x@	28443ZH8003	SPRING, RETURN	2	
11◇%	28443ZH8801	SPRING, RETURN	2	
12@%	28461ZH8003	GRIP, STARTER	1	
13@%	28462ZH8003	ROPE, RECOIL STARTER	1	
15x@	90003ZH8003	SCREW, SETTING	1	
15◇%	90003ZH8801	SCREW, SETTING	1	
16@%	90008ZE2003	BOLT, FLANGE 6 X10	3	

NOTICE

- x GX160K1QX2: Model QP-2TH S/N 2TH-3428 AND BELOW
- ◇ GX160U1QX2: Model QP-2TH S/N 2TH-3429 AND ABOVE

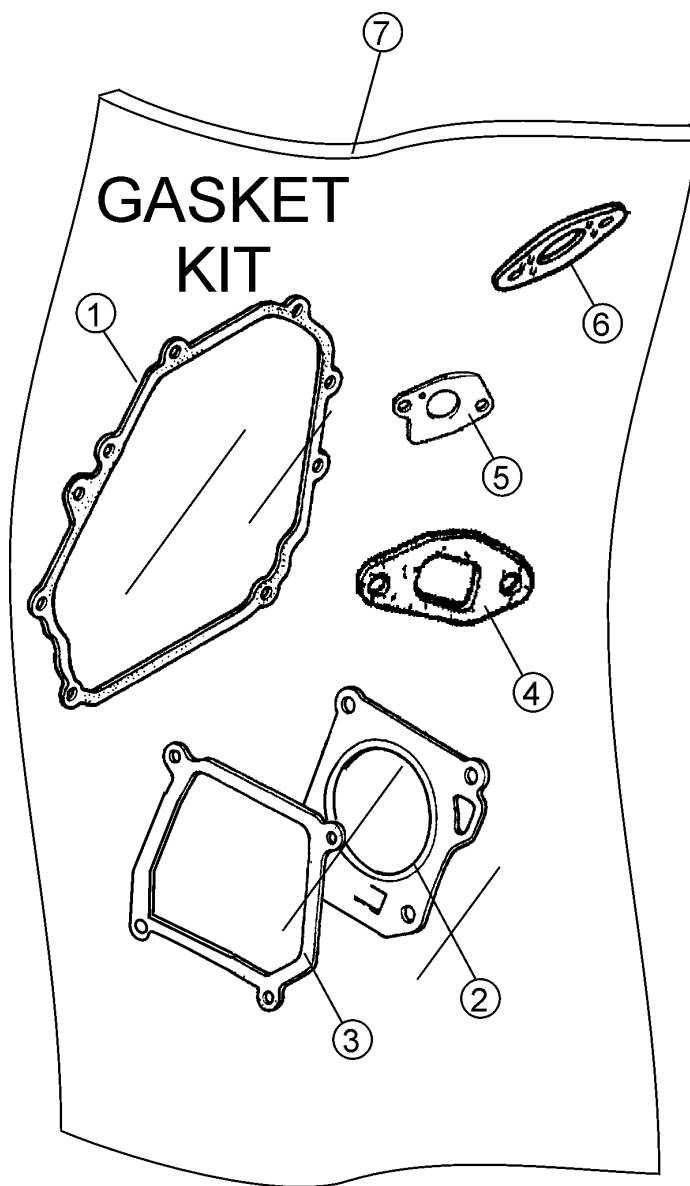

HONDA GX160K1QX2/GX160U1QX2 ENG. — GASKET KIT ASSY.

GASKET KIT ASSY.

<u>NO.</u>	<u>PART NO.</u>	<u>PART NAME</u>	<u>QTY.</u>	<u>REMARKS</u>
1@	11381ZH8801	GASKET CASE COVER (NON- ASBESTOS)	1	
2@	12251ZF1800	GASKET, CYLINDER HEAD	1	
3@	12391ZE1000	GASKET, CYLINDER HEAD COVER	1	
4@	16212ZH8800	GASKET, INSULATOR	1	
5@	16221ZH8801	GASKET, CARBURETOR	1	
6@	18381ZH8800	GASKET, MUFFLER	1	
7	06111ZH8405	GASKET KIT.....	1.....	INCLUDES ITEMS W/@

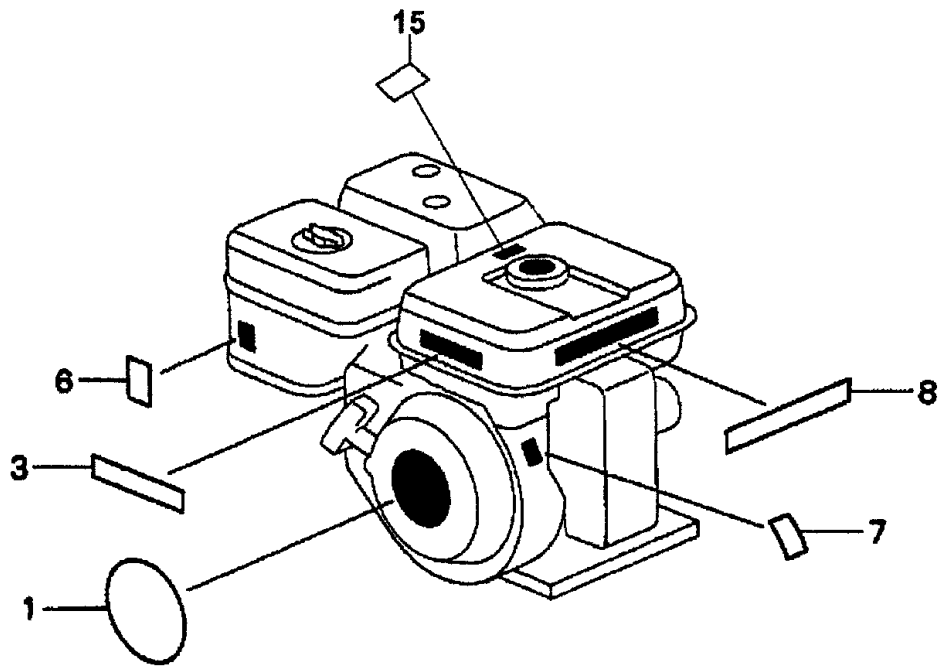

HONDA GX160K1QX2/GX160U1QX2 ENG. — LABELS ASSY.

ENGINE LABELS ASSY.

<u>NO.</u>	<u>PART NO.</u>	<u>PART NAME</u>	<u>QTY.</u>	<u>REMARKS</u>
1	87521ZH8020	ENBLEM 5.5	1	
2	87522ZE1810	MARK, CAUTION (EXTERNAL)	1	
3	87522ZH9000	LABEL, CAUTION	1	
6	87528ZE1810	MARK, CHOKE	1	
7	87530ZH8810	LABEL, SPECIFICATION (EXTERNAL)	1	
8	87532ZH8810	MARK, OIL ALERT (E)	1	
15	887586ZH7W00	LABEL, FUEL CAUTION	1	

TERMS AND CONDITIONS OF SALE — PARTS

PAYMENT TERMS

Terms of payment for parts are net 30 days.

FREIGHT POLICY

All parts orders will be shipped collect or prepaid with the charges added to the invoice. All shipments are F.O.B. point of origin. Multiquip's responsibility ceases when a signed manifest has been obtained from the carrier, and any claim for shortage or damage must be settled between the consignee and the carrier.

MINIMUM ORDER

The minimum charge for orders from Multiquip is \$15.00 net. Customers will be asked for instructions regarding handling of orders not meeting this requirement.

RETURNED GOODS POLICY

Return shipments will be accepted and credit will be allowed, subject to the following provisions:

1. A Returned Material Authorization must be approved by Multiquip prior to shipment.
2. To obtain a Return Material Authorization, a list must be provided to Multiquip Parts Sales that defines item numbers, quantities, and descriptions of the items to be returned.
 - a. The parts numbers and descriptions must match the current parts price list.
 - b. The list must be typed or computer generated.
 - c. The list must state the reason(s) for the return.
 - d. The list must reference the sales order(s) or invoice(s) under which the items were originally purchased.
 - e. The list must include the name and phone number of the person requesting the RMA.
3. A copy of the Return Material Authorization must accompany the return shipment.
4. Freight is at the sender's expense. All parts must be returned freight prepaid to Multiquip's designated receiving point.

5. Parts must be in new and resalable condition, in the original Multiquip package (if any), and with Multiquip part numbers clearly marked.
6. The following items are not returnable:
 - a. Obsolete parts. (If an item is in the price book and shows as being replaced by another item, it is obsolete.)
 - b. Any parts with a limited shelf life (such as gaskets, seals, "O" rings, and other rubber parts) that were purchased more than six months prior to the return date.
 - c. Any line item with an extended dealer net price of less than \$5.00.
 - d. Special order items.
 - e. Electrical components.
 - f. Paint, chemicals, and lubricants.
 - g. Decals and paper products.
 - h. Items purchased in kits.
7. The sender will be notified of any material received that is not acceptable.
8. Such material will be held for five working days from notification, pending instructions. If a reply is not received within five days, the material will be returned to the sender at his expense.
9. Credit on returned parts will be issued at dealer net price at time of the original purchase, less a 15% restocking charge.
10. In cases where an item is accepted, for which the original purchase document can not be determined, the price will be based on the list price that was effective twelve months prior to the RMA date.
11. Credit issued will be applied to future purchases only.

PRICING AND REBATES

Prices are subject to change without prior notice. Price changes are effective on a specific date and all orders received on or after that date will be billed at the revised price. Rebates for price declines and added charges for price increases will not be made for stock on hand at the time of any price change.

Multiquip reserves the right to quote and sell direct to Government agencies, and to Original Equipment Manufacturer accounts who use our products as integral parts of their own products.

SPECIAL EXPEDITING SERVICE

A \$35.00 surcharge will be added to the invoice for special handling including bus shipments, insured parcel post or in cases where Multiquip must personally deliver the parts to the carrier.

LIMITATIONS OF SELLER'S LIABILITY

Multiquip shall not be liable hereunder for damages in excess of the purchase price of the item with respect to which damages are claimed, and in no event shall Multiquip be liable for loss of profit or good will or for any other special, consequential or incidental damages.

LIMITATION OF WARRANTIES

No warranties, express or implied, are made in connection with the sale of parts or trade accessories nor as to any engine not manufactured by Multiquip. Such warranties made in connection with the sale of new, complete units are made exclusively by a statement of warranty packaged with such units, and Multiquip neither assumes nor authorizes any person to assume for it any other obligation or liability whatever in connection with the sale of its products. Apart from such written statement of warranty, there are no warranties, express, implied or statutory, which extend beyond the description of the products on the face hereof.

Effective: February 22, 2006

OPERATION AND PARTS MANUAL

HERE'S HOW TO GET HELP

PLEASE HAVE THE MODEL AND SERIAL
NUMBER ON-HAND WHEN CALLING

UNITED STATES

Multiquip Corporate Office

18910 Wilmington Ave.
Carson, CA 90746
Contact: mq@multiquip.com

Tel. (800) 421-1244
Fax (800) 537-3927

Service Department

800-421-1244
310-537-3700

Fax: 310-537-4259

Technical Assistance

800-478-1244

Fax: 310-943-2238

MQ Parts Department

800-427-1244
310-537-3700

Fax: 800-672-7877
Fax: 310-637-3284

Warranty Department

800-421-1244
310-537-3700

Fax: 310-537-1173

MEXICO

MQ Cipsa

Carr. Fed. Mexico-Puebla KM 126.5
Momoxpan, Cholula, Puebla 72760 Mexico
Contact: pmastretta@cipsa.com.mx

Tel: (52) 222-225-9900
Fax: (52) 222-285-0420

CANADA

Multiquip

4110 Industriel Boul.
Laval, Quebec, Canada H7L 6V3
Contact: jmartin@multiquip.com

Tel: (450) 625-2244
Tel: (877) 963-4411
Fax: (450) 625-8664

UNITED KINGDOM

Multiquip (UK) Limited Head Office

Unit 2, Northpoint Industrial Estate,
Globe Lane,
Dukinfield, Cheshire SK16 4UJ
Contact: sales@multiquip.co.uk

Tel: 0161 339 2223
Fax: 0161 339 3226

© COPYRIGHT 2011, MULTIQUIP INC.

Multiquip Inc and the MQ logo are registered trademarks of Multiquip Inc. and may not be used, reproduced, or altered without written permission. All other trademarks are the property of their respective owners and used with permission.

This manual MUST accompany the equipment at all times. This manual is considered a permanent part of the equipment and should remain with the unit if resold.

The information and specifications included in this publication were in effect at the time of approval for printing. Illustrations, descriptions, references and technical data contained in this manual are for guidance only and may not be considered as binding. Multiquip Inc. reserves the right to discontinue or change specifications, design or the information published in this publication at any time without notice and without incurring any obligations.

Your Local Dealer is:

