

OPERATION AND PARTS MANUAL



MODEL GAC3.6HZ PORTABLE GENERATOR (HONDA GX240 GASOLINE ENGINE)

Revision #1 (03/31/10)

To find the latest revision of this
publication, visit our website at:
www.multiquip.com



THIS MANUAL MUST ACCOMPANY THE EQUIPMENT AT ALL TIMES.

TABLE OF CONTENTS

GAC3.6HZ Portable 60 Hz Generator

Table Of Contents	2
Parts Ordering Procedures.....	3
Safety Information	4-8
Specifications (Generator).....	12
Specifications (Engine).....	11
Dimensions.....	12
Installation	14-15
General Information.....	16
Components (Generator).....	17-18
Inspection/Setup.....	19-20
Operation.....	22-23
Operation/Shutdown.....	23
Preparation For Long Term Storage	24
Maintenance	25-26
Generator Wiring Diagram	27
Troubleshooting (Engine).....	28-29
Troubleshooting (Generator).....	30
Explanation Of Code In Remarks Column	32
Suggested Spare Parts	33

Component Drawings

Nameplate and Decals Assembly.....	34-35
Generator Assembly	36-37
Control Box Assembly	38-39
Muffler Assembly	40-41
Pipe Frame Assembly.....	42-43

Honda GX240K1EDN2/ GX240U1EDN2 Engines

Cylinder Head Assembly	44-45
Cylinder Barrel Assembly	46-47
Crankcase Cover Assembly	48-49
Crankshaft Assembly.....	50-51
Piston Assembly	52-53
Camshaft Assembly.....	54-55
Recoil Starter Assembly	56-57
Fan Cover Assembly.....	58-59
Carburetor Assembly	60-63
Air Cleaner Assembly	64-65
Flywheel Assembly	66-67
Ignition Coil Assembly	68-69
Governor Control Assembly.....	70-71
Auto Throttle Assembly.....	72-73
Fuel Cock Assembly	74-75
Decal Assembly	76-77
Tool Kit.....	78-79
Terms And Conditions Of Sale — Parts	80

NOTICE

Specifications and part numbers are subject to change without notice.

PARTS ORDERING PROCEDURES

Ordering parts has never been easier! Choose from three easy options:

Effective:
January 1st, 2006

www.multiquip.com



Order via Internet (Dealers Only):

Order parts on-line using Multiquip's SmartEquip website!

- View Parts Diagrams
- Order Parts
- Print Specification Information



If you have an MQ Account, to obtain a Username and Password, E-mail us at: parts@multiquip.com.

To obtain an MQ Account, contact your District Sales Manager for more information.

Goto www.multiquip.com and click on **Order Parts** to log in and save!

Use the **internet** and qualify for a **5% Discount** on **Standard orders** for all orders which include complete part numbers.*

Note: Discounts Are Subject To Change



Order via Fax (Dealers Only):

All customers are welcome to order parts via Fax.

Domestic (US) Customers dial:
1-800-6-PARTS-7 (800-672-7877)

Fax your order in and qualify for a **2% Discount** on **Standard orders** for all orders which include complete part numbers.*

Note: Discounts Are Subject To Change



Order via Phone: Domestic (US) Dealers Call:
1-800-427-1244

Non-Dealer Customers:

Contact your local Multiquip Dealer for parts or call 800-427-1244 for help in locating a dealer near you.



International Customers should contact their local Multiquip Representatives for Parts Ordering information.

When ordering parts, please supply:

- | | |
|---|--|
| <input type="checkbox"/> Dealer Account Number | <input type="checkbox"/> Specify Preferred Method of Shipment: |
| <input type="checkbox"/> Dealer Name and Address | <input checked="" type="checkbox"/> UPS/Fed Ex <input checked="" type="checkbox"/> DHL |
| <input type="checkbox"/> Shipping Address (if different than billing address) | <input type="checkbox"/> Priority One <input checked="" type="checkbox"/> Truck |
| <input type="checkbox"/> Return Fax Number | <input type="checkbox"/> Ground |
| <input type="checkbox"/> Applicable Model Number | <input type="checkbox"/> Next Day |
| <input type="checkbox"/> Quantity, Part Number and Description of Each Part | <input type="checkbox"/> Second/Third Day |

NOTICE

All orders are treated as *Standard Orders* and will ship the same day if received prior to 3PM PST.

WE ACCEPT ALL MAJOR CREDIT CARDS!



SAFETY INFORMATION

Do not operate or service the equipment before reading the entire manual. Safety precautions should be followed at all times when operating this equipment. Failure to read and understand the safety messages and operating instructions could result in injury to yourself and others.

SAFETY MESSAGES

The four safety messages shown below will inform you about potential hazards that could injure you or others. The safety messages specifically address the level of exposure to the operator and are preceded by one of four words: **DANGER**, **WARNING**, **CAUTION** or **NOTICE**.

SAFETY SYMBOLS

 **DANGER**

Indicates a hazardous situation which, if not avoided, **WILL** result in **DEATH** or **SERIOUS INJURY**.

 **WARNING**

Indicates a hazardous situation which, if not avoided, **COULD** result in **DEATH** or **SERIOUS INJURY**.





 **CAUTION**

Indicates a hazardous situation which, if not avoided, **COULD** result in **MINOR** or **MODERATE INJURY**.

NOTICE

Addresses practices not related to personal injury.

Potential hazards associated with the operation of this equipment will be referenced with hazard symbols which may appear throughout this manual in conjunction with safety messages.

Symbol	Safety Hazard
	Lethal exhaust gas hazards
	Explosive fuel hazards
	Burn hazards
	Overspeed hazards
	Electric shock hazards

SAFETY INFORMATION

GENERAL SAFETY

CAUTION

- **NEVER** operate this equipment without proper protective clothing, shatterproof glasses, respiratory protection, hearing protection, steel-toed boots and other protective devices required by the job or city and state regulations.



- **NEVER** operate this equipment when not feeling well due to fatigue, illness or when under medication.



- **NEVER** operate this equipment under the influence of drugs or alcohol.



- **ALWAYS** check the equipment for loosened threads or bolts before starting.
- **DO NOT** use the equipment for any purpose other than its intended purposes or applications.

NOTICE

- This equipment should only be operated by trained and qualified personnel 18 years of age and older.
- Whenever necessary, replace nameplate, operation and safety decals when they become difficult read.
- Manufacturer does not assume responsibility for any accident due to equipment modifications. Unauthorized equipment modification will void all warranties.

- **NEVER** use accessories or attachments that are not recommended by Multiquip for this equipment. Damage to the equipment and/or injury to user may result.

- **ALWAYS** know the location of the nearest **fire extinguisher**.



- **ALWAYS** know the location of the nearest **first aid kit**.



- **ALWAYS** know the location of the nearest phone or **keep a phone on the job site**. Also, know the phone numbers of the nearest **ambulance, doctor** and **fire department**. This information will be invaluable in the case of an emergency.



GENERATOR SAFETY

DANGER

- **NEVER** operate the equipment in an explosive atmosphere or near combustible materials. An explosion or fire could result causing severe **bodily harm or even death**.



WARNING

- **NEVER** disconnect any **emergency or safety devices**. These devices are intended for operator safety. Disconnection of these devices can cause severe injury, bodily harm or even death. Disconnection of any of these devices will void all warranties.

CAUTION

- **NEVER** lubricate components or attempt service on a running machine.

NOTICE

- **ALWAYS** ensure generator is on level ground before use.
- **ALWAYS** keep the machine in proper running condition.
- Fix damage to machine and replace any broken parts immediately.
- **ALWAYS** store equipment properly when it is not being used. Equipment should be stored in a clean, dry location out of the reach of children and unauthorized personnel

SAFETY INFORMATION

ENGINE SAFETY

DANGER

- The engine fuel exhaust gases contain poisonous carbon monoxide. This gas is colorless and odorless, and can cause death if inhaled.
- The engine of this equipment requires an adequate free flow of cooling air. **NEVER** operate this equipment in any enclosed or narrow area where free flow of the air is restricted. If the air flow is restricted it will cause injury to people and property and serious damage to the equipment or engine.

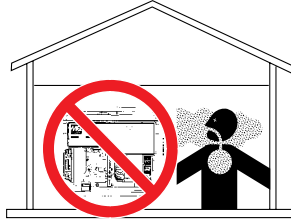

WARNING

- **NEVER** operate the engine with heat shields or guards removed.
- **DO NOT** remove the engine oil drain plug while the engine is hot. Hot oil will gush out of the engine crankcase and severely scald any persons in the general area of the generator.

CAUTION

- **NEVER** touch the hot exhaust manifold, muffler or cylinder. Allow these parts to cool before servicing equipment.



NOTICE

- **NEVER** run engine without an air filter or with a dirty air filter. Severe engine damage may occur. Service air filter frequently to prevent engine malfunction.
- **NEVER** tamper with the factory settings of the engine or engine governor. Damage to the engine or equipment can result if operating in speed ranges above the maximum allowable.
- State Health Safety Codes and Public Resources Codes specify that in certain locations, spark arresters must be used on internal combustion engines that use hydrocarbon fuels. A spark arrester is a device designed



to prevent accidental discharge of sparks or flames from the engine exhaust. Spark arresters are qualified and rated by the United States Forest Service for this purpose. In order to comply with local laws regarding spark arresters, consult the engine distributor or the local Health and Safety Administrator.

FUEL SAFETY

DANGER

- **DO NOT** add fuel to equipment if it is placed inside truck bed with plastic liner. Possibility exists of explosion or fire due to static electricity.

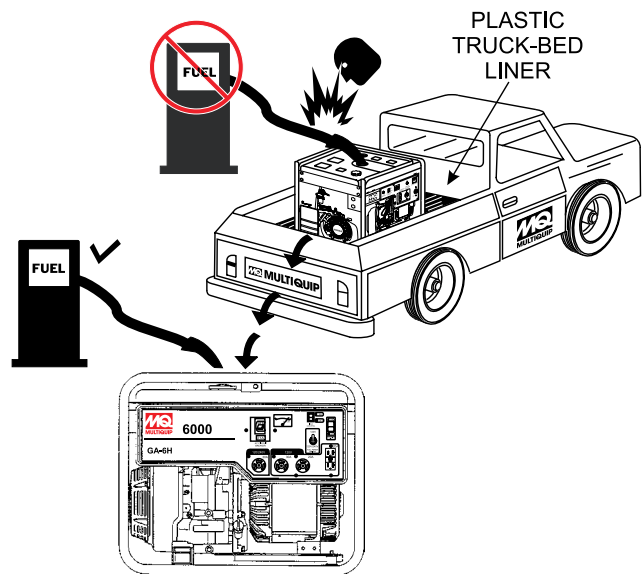

- **DO NOT** start the engine near spilled fuel or combustible fluids. Diesel fuel is extremely flammable and its vapors can cause an explosion if ignited.
- **ALWAYS** refuel in a well-ventilated area, away from sparks and open flames.
- **ALWAYS** use extreme caution when working with **flammable** liquids.
- **DO NOT** fill the fuel tank while the engine is running or hot.
- **DO NOT** overfill tank, since spilled fuel could ignite if it comes into contact with hot engine parts or sparks from the ignition system.
- Store fuel in appropriate containers, in well-ventilated areas and away from sparks and flames.

SAFETY INFORMATION

- **NEVER** use fuel as a cleaning agent.
- **DO NOT** smoke around or near the equipment. Fire or explosion could result from fuel vapors or if fuel is spilled on a hot engine.



ELECTRICAL SAFETY

DANGER

- Turn generator and all circuit breakers **OFF** before performing maintenance on the generator or making contact with output receptacles.

- **NEVER** insert any objects into the output receptacles during operation. This is extremely dangerous. The possibility exists of **electrical shock, electrocution or death.**



- Backfeed to a utility system can cause **electrocution** and/or property damage. **NEVER** connect the generator to a building's electrical system without a transfer switch or other approved device. All installations should be performed by a **licensed electrician** in accordance with all applicable laws and electrical codes. Failure to do so could result in electrical shock or burn, causing **serious injury or even death.**



Power Cord/Cable Safety

DANGER

- **NEVER** let power cords or cables **lay in water.**
- **NEVER** stand in **water** while AC power from the generator is being transferred to a load.
- **NEVER** use **damaged** or **worn** cables or cords when connecting equipment to generator. Inspect for cuts in the insulation.
- **NEVER** grab or touch a live power cord or cable with wet hands. The possibility exists of **electrical shock, electrocution or death.**



- Make sure power cables are securely connected to the generator's output receptacles. Incorrect connections may cause electrical shock and damage to the generator.

NOTICE

- **ALWAYS** make certain that proper power or extension cord has been selected for the job. See Cable Selection Chart in this manual.

Grounding Safety

DANGER

- **ALWAYS** make sure that electrical circuits are properly grounded to a suitable earth ground (ground rod) per the National Electrical Code (NEC) and local codes before operating generator. **Severe injury or death by electrocution** can result from operating an ungrounded generator.

- **NEVER** use gas piping as an electrical ground.

BATTERY SAFETY (ELECTRIC START ONLY)

DANGER

- **DO NOT** drop the battery. There is a possibility that the battery will explode.
- **DO NOT** expose the battery to open flames, sparks, cigarettes, etc. The battery contains combustible gases and liquids. If these gases and liquids come into contact with a flame or spark, an explosion could occur.
- **DO NOT** charge battery if frozen. Battery can explode. When frozen, warm the battery to at least 61°F (16°C).

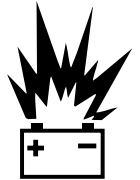

WARNING

- **ALWAYS** wear safety glasses when handling the battery to avoid eye irritation. The battery contains acids that can cause injury to the eyes and skin.
- Use well-insulated gloves when picking up the battery.
- **ALWAYS** keep the battery charged. If the battery is not charged, combustible gas will build up.
- **ALWAYS** recharge the battery in a well-ventilated environment to avoid the risk of a dangerous concentration of combustible gasses.



SAFETY INFORMATION

- If the battery liquid (dilute sulfuric acid) comes into contact with **clothing or skin**, rinse skin or clothing immediately with plenty of water.
- If the battery liquid (dilute sulfuric acid) comes into contact with **eyes**, rinse eyes immediately with plenty of water and contact the nearest doctor or hospital to seek medical attention.

CAUTION

- **ALWAYS** disconnect the **NEGATIVE** battery terminal before performing service on the generator.
- **ALWAYS** keep battery cables in good working condition. Repair or replace all worn cables.

TRANSPORTING SAFETY

CAUTION

- **NEVER** allow any person or animal to stand underneath the equipment while lifting.

NOTICE

- Before lifting, make sure that the equipment parts (lifting bail if equipped) are not damaged and screws are not loose or missing.
- Always make sure crane or lifting device has been properly secured to the lifting bail (hook) of the equipment.
- **ALWAYS** shutdown engine before transporting.
- **NEVER** lift the equipment while the engine is running.
- Tighten fuel tank cap securely and close fuel cock to prevent fuel from spilling.
- Use adequate lifting cable (wire or rope) of sufficient strength.
- Use one point suspension hook and lift straight upwards.
- **DO NOT** lift machine to unnecessary heights.
- **ALWAYS** tie down equipment during transport by securing the equipment with rope.

ENVIRONMENTAL SAFETY

NOTICE

- Dispose of hazardous waste properly. Examples of potentially hazardous waste are used motor oil, fuel and fuel filters.
- **DO NOT** use food or plastic containers to dispose of hazardous waste.
- **DO NOT** pour waste, oil or fuel directly onto the ground, down a drain or into any water source.



SPECIFICATIONS (GENERATOR)

Table 1. Specifications (Generators)		
AC Generator 60 Hz AC Power Sourc	Model	GAC3.6HZ
	Type	Brushless Revolving Field Type
	Excitation	Solid State, Statically Excited System
	Speed	3,600 RPM
	Cooling System	Self-Ventilation
	Continuous Power Output	3.2 kW
	Max Power Output	3.6 kW
	Rated Voltage	120/240V
	Current Max/Continuous (120V)	30.0/26.6 amps
	Current Max/Continuous (240V)	15.0/13.3 amps
	Phase	Single Phase (4 wire)
	Frequency	60 Hz
	Power Factor	1
Dimensions (L x W x H)	25.0 x 19.75 X 18.75 in. (635 X 501 X 476 mm)	
Dry Net Weight	165 lbs. (75 kg.)	

NOTICE

In keeping with Multiquip's policy of constantly improving its products, the specifications quoted herein are subject to change without prior notice.

SPECIFICATIONS (ENGINE)

Table 2. Specifications (Engine)		
Engine	Model	HONDA GX240K1EDN2 HONDA GX240U1EDN2
	Type	Air-cooled 4 stroke, Single Cylinder, OHV, Horizontal Shaft Gasoline Engine
	Bore X Stroke	2.87 in. X 2.28 in. (73 mm x 58 mm.)
	Displacement	14.75 cu-in (242 cm ³)
	Max Output	8.0 H.P./3600 R.P.M.
	Fuel	Unleaded Automobile Gasoline
	Fuel Capacity	5 gallons (19 liters)
	Lube Oil Capacity	1.16 quarts (1.1 liters)
	Oil Alert System	Yes
	Speed Control Method	Centrifugal Fly-weight Type
	Starting Method	Recoil Start
Dimensions (L x W x H)		15.0 x 16.9 X 16.6 in. (380 X 430 X 422 mm)
Dry Net Weight		55.1 lbs. (25 kg.)

Effects of Altitude and Heat

The maximum output of the engines listed above are applicable to supplying electrical power for continuous service at ambient conditions in accordance with SAE Test cord J607. The above ambient conditions are at standard sea level, with a barometric reading of 29.92 inches and a temperature of 60° F (15.5° C).

Generally, the engine's output power will decrease 3-1/2% for each 1000 feet (305 meters) of altitude above sea level, and 1% for each 10° F (-12.2° C) above the standard temperature of 60° F (15.5° C).

DIMENSIONS

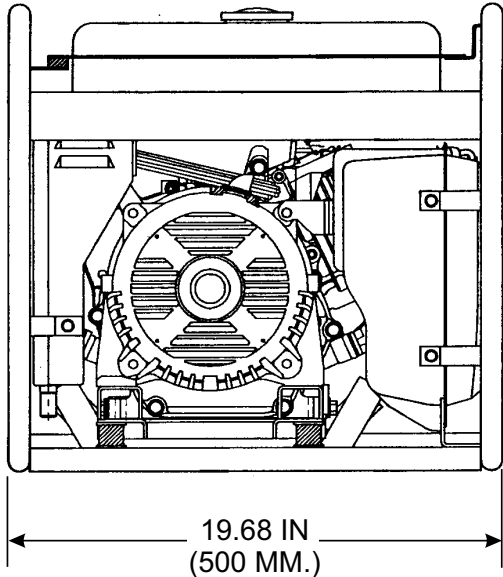
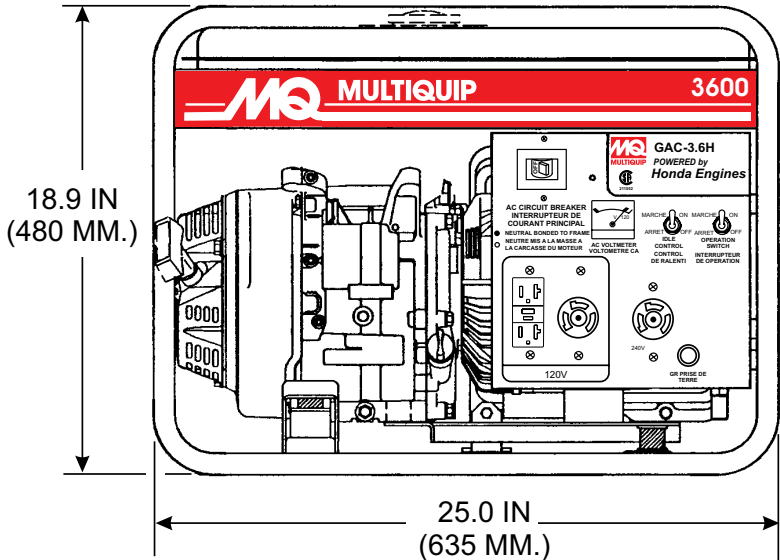

Figure 1. Dimensions

CONNECTING THE GROUND

The nut and ground terminal on the generators should always be used to connect the generators to a suitable ground. The ground cable should be #8 size wire minimum.

At the generator, connect the terminal of the ground cable between the lock washer and the nut (Figure 2) and tighten the nut fully. Connect the other end of the ground cable to a suitable earth ground (ground rod).

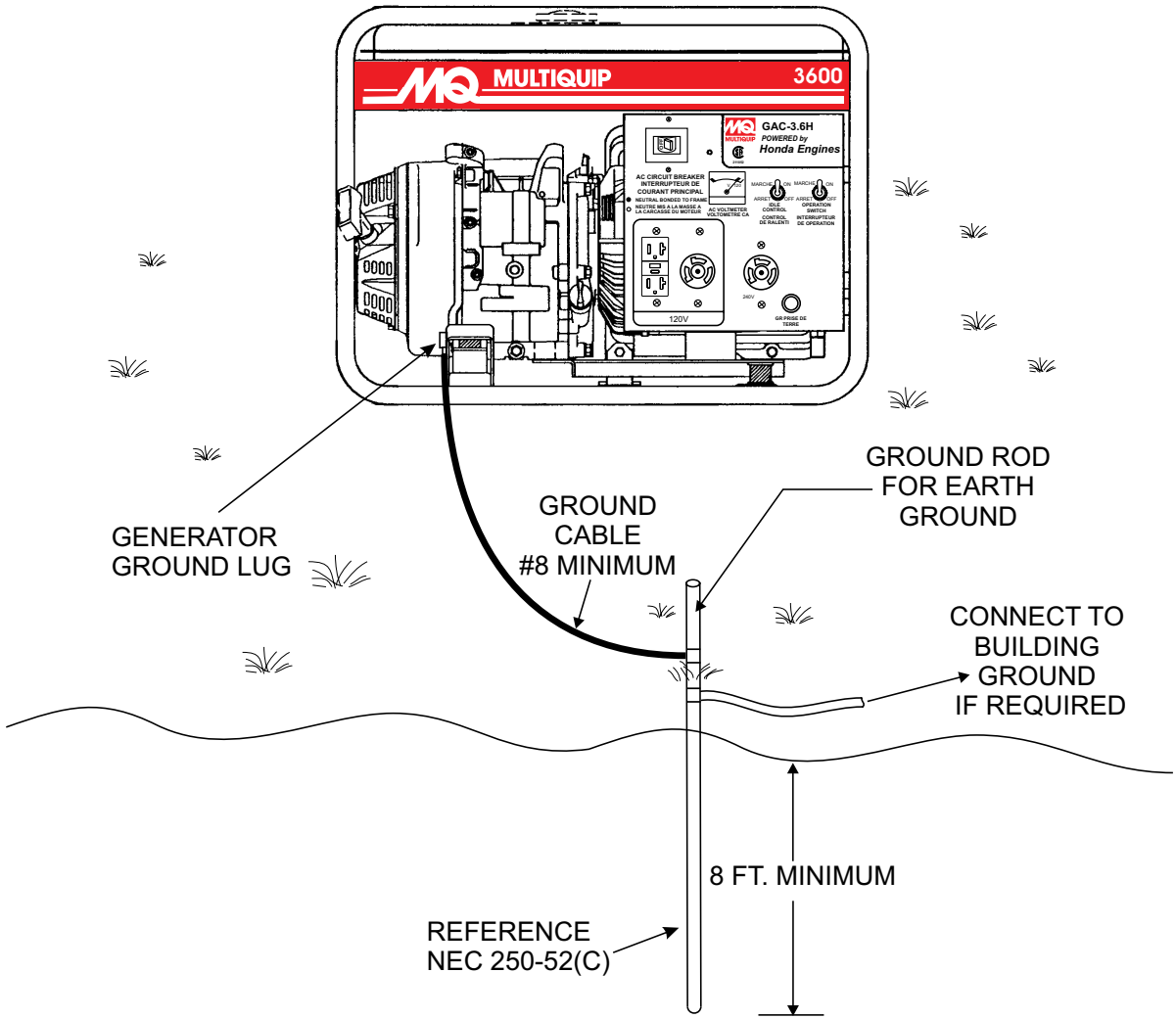

Figure 2. Generator Grounding

OUTDOOR INSTALLATION

If possible install the generator in a area that is free of debris, bystanders, and overhead obstructions. Make sure the generator is on secure level ground so that it cannot slide or shift around.

The installation site must be relatively free from moisture and dust. All electrical equipment should be protected from excessive moisture. Failure to do will result in deterioration of the insulation and will result in short circuits and grounding.

Foreign materials such as dust, sand, lint and abrasive materials have a tendency to cause excessive wear to engine and alternator parts.

INDOOR INSTALLATION

 **WARNING**

 Pay close attention to ventilation when operating the generator inside tunnels and caves. The engine exhaust contains noxious elements. Engine exhaust must be routed to a ventilated area

Exhaust gases from gas engines are extremely poisonous. Whenever an engine is installed indoors the exhaust fumes must be vented to the outside. The engine should be installed at least two feet from any outside wall. Using an exhaust pipe which is too long or too small can cause excessive back pressure which will cause the engine to heat excessively and possibly burn the valves.

PLACEMENT

The generators should always be placed on a flat level surface when it is running. **DO NOT** place the generators on slopes, the possibility exists that the generators could slide.

 **DANGER**

 An electric shock is apt to happen when vibrators are used. Pay close attention to handling when operating vibrators and always use rubber boots and gloves to insulate the body from a short circuit.

GENERATOR GROUNDING

To guard against electrical shock and possible damage to the equipment, it is important to provide a good **EARTH** ground.

Article 250 (Grounding) of the National Electrical Code (NEC) provides guide lines for proper grounding and specifies that the cable ground shall be connected to the grounding system of the building as close to the point of cable entry as practical.

NEC articles 250-64(b) and 250-66 set the following grounding requirements:

1. Use one of the following wire types to connect the generator to earth ground.
 - a. Copper - 10 AWG (5.3 mm²) or larger.
 - b. Aluminum - 8 AWG (8.4 mm²) or larger.
2. When grounding the generator (Figure 2) connect the ground cable between the lock washer and the nut on the generator and tighten the nut fully. Connect the other end of the ground cable to earth ground.
3. NEC article 250-52(c) specifies that the earth ground rod should be buried a minimum of 8 ft. into the ground.

NOTICE

When connecting the generator to any buildings electrical system **ALWAYS** consult with a licensed electrician.

GAC3.6HZ FAMILIARIZATION

Generator

The Multiquip GAC3.6HZ generator has been designed as a portable dual purpose power source for 60 Hz (single phase) lighting facilities, power tools, submersible pumps and other industrial and construction machinery.

These generators are mounted on rubber vibration isolators that have a steel base backplate which is attached to the protective steel pipe carrying frame. The protective carrying frame is made of steel tubing and fully wraps around the generators to protect against damage. See Figures 3, and 4 for the basic controls and indicators for the generator.

These portable generators are supplied with a electrical control box. To reduce vibration caused by the engine, the control box is also placed on rubber isolators.

Control Box

The control box is provided with the following:

- 240V twist-lock output receptacle (single phase).
- 120V twist-lock receptacle (single phase).
- 120V GFCI receptacle.
- 15 Amp Main Circuit Breaker.
- AC Voltmeter
- Ground Terminal
- Idle Control Switch
- Operation Switch

DANGER

Before connecting this generators to any building's electrical system, a licensed electrician must install an isolation (transfer) switch.

Serious injury or death may result without this transfer switch.

COMPONENTS (GENERATOR)

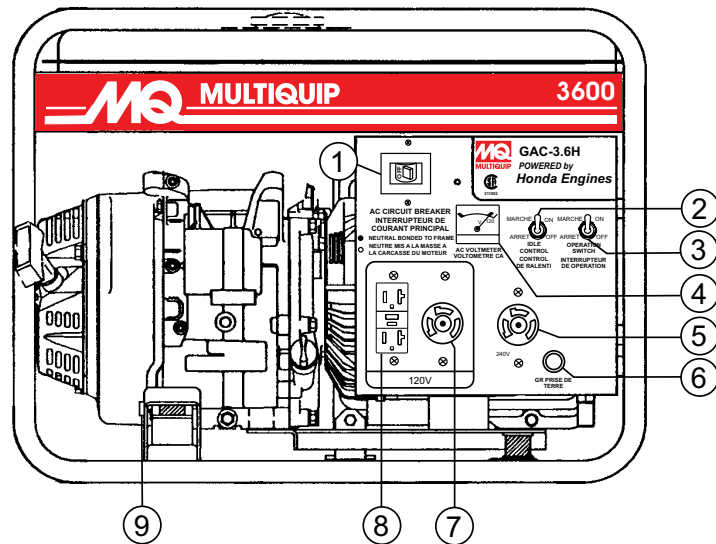

Figure 3. Generator Components

- 1. Main Breaker** – 2-pole, 15 amp circuit breaker protects the generator from short circuiting or overloading. When starting the generator always have circuit breaker placed in the **OFF** position.
- 2. Idle Control Switch** – The generator is provided with an automatic idle control device for noise suppression and reduced fuel consumption. The automatic idle control automatically engages under a no-load condition.

With the automatic idle control switched **ON**, the engine revolutions will automatically drop to about 2600 rpm (low-speed operation) within 3 seconds after the load stops. When the operation is resumed, the engine speed is automatically increased to about 3600 rpm (high-speed operation) as soon as the load is connected.
- 3. Operation Switch** – Place switch in **ON** position (up) for normal operation. To turn-off the generator, place switch in **OFF** position (down).
- 4. AC-Voltmeter** – Indicates (with a mark) the rated 60 Hz (single-phase) output voltage. In addition the voltmeter can also be used as a diagnostic tool. If the voltmeter indicator (needle) is below the rated voltage, engine problems may exist (low/high RPM's).

To prevent damage to the generator or power tools due to low output voltage, turn the generator **OFF** and consult your authorized Multiquip service dealer.
- 5. 240V Output Receptacle** – NEMA L6-20R twist-lock receptacle will provide 240V @ 20 amps, 60 Hz.
- 6. GFCI Ground** – GFCI ground connection point.
- 7. 120V Output Receptacle** – NEMA L5-30R twist-lock receptacle will provide 120V @ 30 amps, 60 Hz.
- 8. GFCI Duplex Receptacle** – NEMA 5-15R, GFCI receptacle will provide 120V @ 15 amps.
- 9. Chassis Ground** – This ground connection point should be connected to a good earth ground (ground rod).

COMPONENTS (GENERATOR)

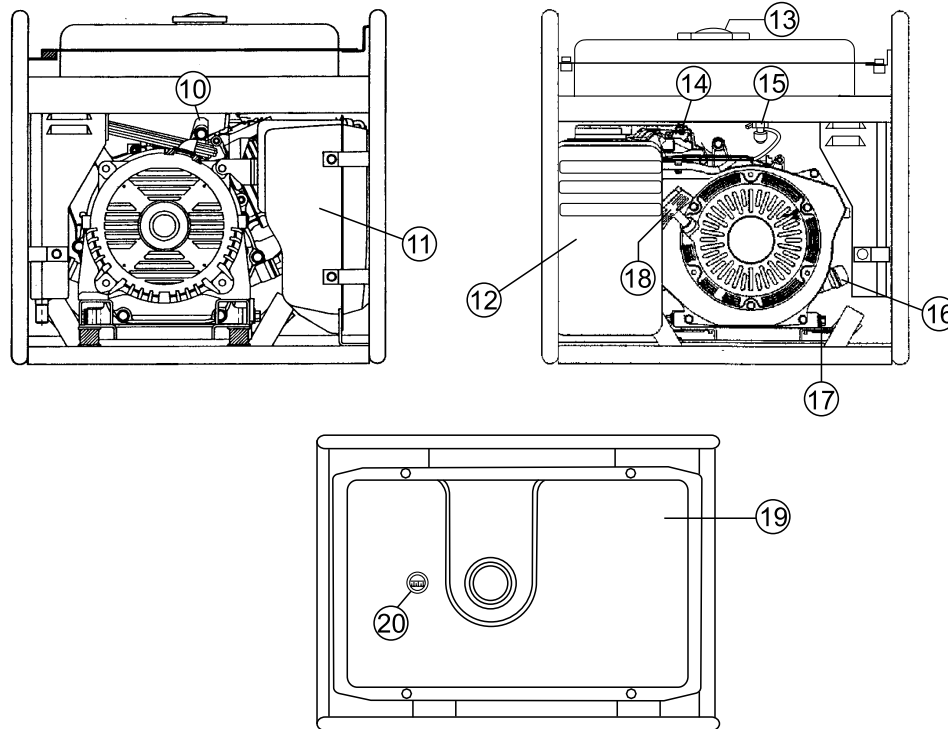

Figure 4. Generator Components (Continued)

10. **Spark Plug** – Provides spark to the ignition system. Set spark plug gap to 0.6 - 0.7 mm (0.028 - 0.031 inch) Clean spark plug once a week.
11. **Muffler/Heat Shield** – Used to reduce noise and emissions. **NEVER** touch this heat shield when the generator/welder is in use. Always allow time for engine to cool before servicing.
12. **Air Cleaner** – Prevents dirt and other debris from entering the fuel system. Remove wing-nut on top of air filter cannister to gain access to filter element. **NEVER** run the engine without an air cleaner.
13. **Fuel Tank Cap** – Remove cap to add unleaded gasoline to the fuel tank. Replenish with clean unleaded gasoline. Make sure cap is tightened securely. **DO NOT** over fill.
14. **Choke Lever** – Used for starting the engine. Close the choke lever when starting a cold engine or in cold weather conditions. The choke enriches the fuel mixture. Open the choke lever if starting a warm engine or in warm weather conditions.
15. **Fuel Cock Lever** – Turn lever downward to start (down) the flow of fuel into the carburetor. Turn upward to stop (up) the flow of fuel.
16. **Engine Oil Filler Cap** – Remove cap/dipstick when the adding of engine oil is required. See Table 4 for recommended type engine oil.
17. **Engine Oil Drain Plug** – Remove drain plug when draining of the oil from the engine crankcase is required. Fill with recommended type oil as listed in Table 4.
18. **Recoil Starter (pull rope)** – Manual-starting method. Pull the starter grip until resistance is felt, then pull briskly and smoothly.
19. **Fuel Tank** – Fuel tank capacity is 5 gallons (19 liters)
20. **Fuel Gauge** – This gauge is located on top of the fuel tank. Read this gauge to determine when fuel is low.

NOTICE

This **HONDA** engine is equipped with a low oil shutdown capability. A built in sensor will automatically turn off the engine should the oil level fall below a safe operating condition. Make sure the generator is placed on level ground. Placing the generator on level ground will ensure that the low oil sensor will function properly.

GENERAL INSPECTION PRIOR TO OPERATION

Ground Power Tools

When using power tools or electrical equipment requiring AC power from the generator, make sure power tool cord has a ground pin or is double insulated as shown in Figure 5.

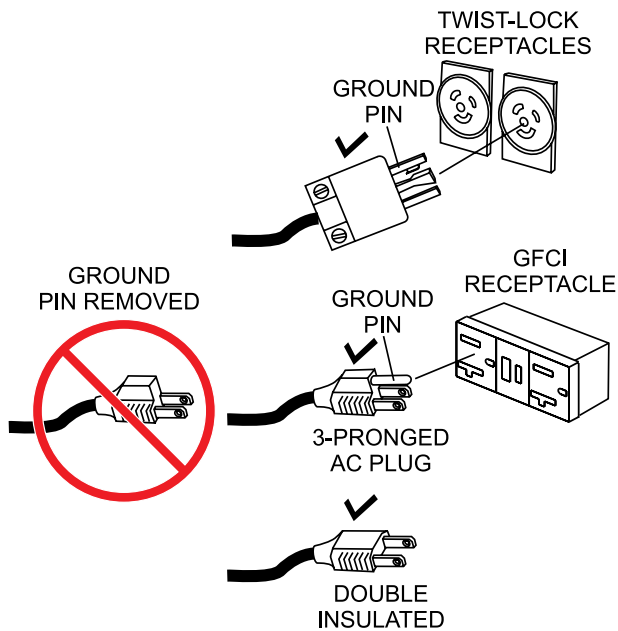

Figure 5. Ground Pin

NOTICE

Double-insulated power tools and small appliances have specially insulated housings that eliminate the need for a ground pin. These types of double-insulated power cords are designed so that no part of the device will be electrically live even if the internal insulation fails.

Extension Cable

When electric power is to be provided to various tools or loads at some distance from the generator, extension cords are normally used. Cables should be sized to allow for distance in length and amperage so that the voltage drop between the generators and point of use (load) is held to a minimum. Use the cable selection chart (Table 3) as a guide for selecting proper cable size.

DANGER

NEVER use power tools or equipment that do not have a ground capability, the possibility exists of electrocution, electrical shock or burn, which can cause severe bodily harm or even **DEATH!**

Main Circuit Breaker

ALWAYS place the main circuit breaker in the **OFF** position prior to starting the engine.

Table 3. Cable Selection (60 Hz, Single Phase Operation)

Current In Amperes	Load In Watts		Maximum Allowable Cable Length			
	120 Volts	240 Volts	#10 Wire	#12 Wire	#14 Wire	#16 Wire
2.5	300	600	1000 ft.	600 ft.	375 ft.	250 ft.
5	600	1200	500 ft.	300 ft.	200 ft.	125 ft.
7.5	900	1800	350 ft.	200 ft.	125 ft.	100 ft.
10	1200	2400	250 ft.	150 ft.	100 ft.	
15	1800	3600	150 ft.	100 ft.	65 ft.	
20	2400	4800	125 ft.	75 ft.	50 ft.	

CAUTION: Equipment damage can result from low voltage.

Before Starting

1. Read safety instructions at the beginning of manual.
2. Clean the generator, removing dirt and dust, particularly the engine cooling air inlet, carburetor and air cleaner.
3. Check the air filter for dirt and dust. If air filter is dirty, replace air filter with a new one as required.
4. Check carburetor for external dirt and dust. Clean with dry compressed air.
5. Check fastening nuts and bolts for tightness

Engine Oil Check

1. To check the engine oil level, place the generator on secure level ground with the engine stopped.
2. Remove the filler dipstick from the engine oil filler hole (Figure 6) and wipe clean.

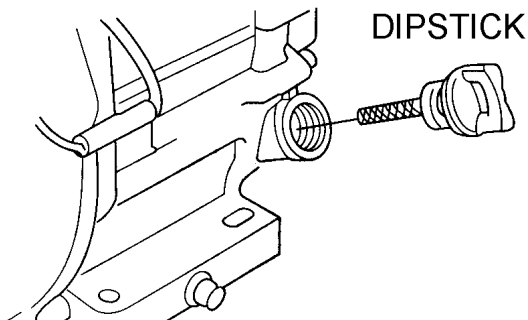

Figure 6. Engine Oil Dipstick Removal

3. Insert and remove the dipstick without screwing it into the filler neck. Check the oil level shown on the dipstick.
4. If the oil level is low (Figure 7), fill to the edge of the oil filler hole with the recommended oil type (Table 4). Maximum oil capacity is 1.16 quarts (1.1 liters).

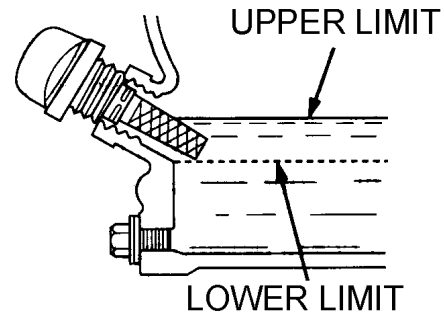

Figure 7. Engine Oil Dipstick(Oil Level)

Table 4. Oil Type

Season	Temperature	Oil Type
Summer	25°C or Higher	SAE 10W-30
Spring/Fall	25°C~10°C	SAE 10W-30/20
Winter	0°C or Lower	SAE 10W-10

Fuel Check

1. Close the fuel cock before filling the fuel tank.
2. Remove the fuel cap located on top of fuel tank.
3. Read the fuel gauge located on top of the fuel tank (Figure 8) to determine if the fuel level is low. If fuel is low, replenish with clean unleaded fuel.

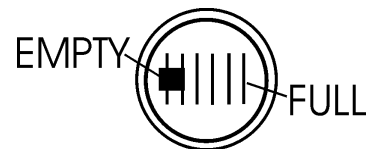

Figure 8. Fuel Gauge

4. When refueling, be sure to use a strainer for filtration. **DO NOT** top-off fuel. **DO NOT** fill the tank beyond capacity. Wipe up any spilled fuel **immediately!**

This section is intended to assist the operator with the initial start-up of the portable generator. It is extremely important that this section be read carefully before attempting to use the generators in the field.

Before Starting the Engine

1. Be sure to disconnect all electrical loads from the generators prior to starting the engine.
2. **NEVER** start the engine with the main circuit breaker in the **ON** position. Always place this circuit breaker (Figure 9) in the **OFF** position before starting.

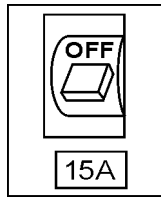

Figure 9. Main Circuit Breaker (OFF)

Starting the Engine

1. Place the engine fuel valve lever (Figure 10) to the **ON** position.

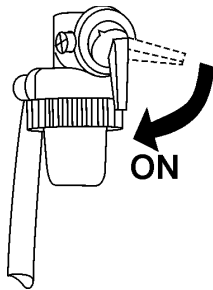

Figure 10. Engine Fuel Valve Lever (ON)

2. Place the choke lever (Figure 11) in the **CLOSED** position if starting a cold engine.

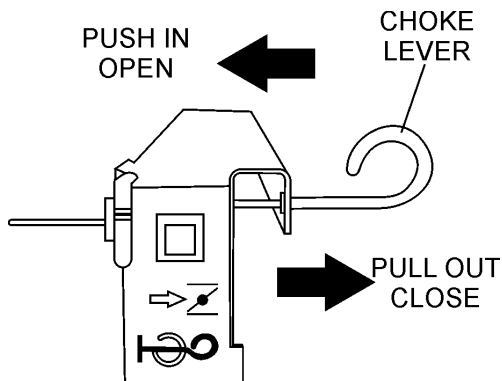

Figure 11. Choke Lever

3. Place the choke lever (Figure 11) in the **OPEN** position if starting a warm engine or the temperature is warm.
4. Place the generator's operation switch (Figure 12) in the **ON** position.

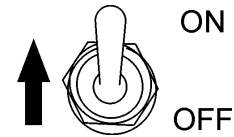

Figure 12. Operation Switch (ON)

5. Grasp the starter grip (Figure 13) and slowly pull it out. The resistance becomes the hardest at a certain position, corresponding to the compression point. Pull the starter grip briskly and smoothly for starting.

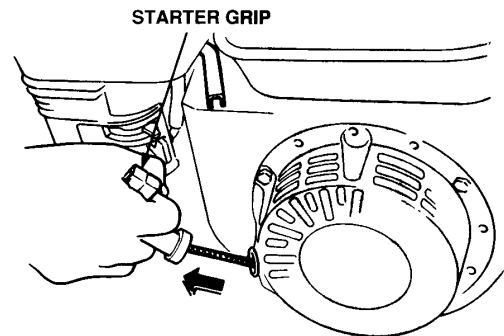

Figure 13. Starter Grip

6. If the engine has started, slowly return the choke lever (Figure 11) to the **OPEN** position. If the engine has not started repeat steps 1 through 5.

NOTICE

DO NOT pull the starter rope all the way to the end.

DO NOT release the starter rope after pulling. Allow it to rewind as soon as possible..

OPERATION

- Before the generator is placed into operation, run the engine for 3-5 minutes. Check for abnormal smells, fuel leaks, and noises that would associate with loose components.
- Place the idle control switch (Figure 14) in the **OFF** (down) position. This will allow the engine speed to run at about 3600 RPM's.

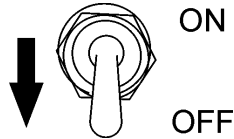

Figure 14. Idle Control Switch (OFF)

NOTICE

Placing the idle control switch in the **OFF** position (Figure 14) allows the engine to operate at a maximum speed of about 3600 RPM's.

When the idle control switch (Figure 15) is placed in the up position (**ON**), the generator will run at idle speed (2200 RPM's) until a load is applied, at that time the engine speed will increase to 3600 RPM's as long as a load is being applied.

When the load is not in use, the engine speed will drop back to the idle mode after about 3 seconds.

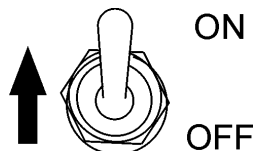

Figure 15. Idle Control Switch (ON)

- Place main circuit breaker (Figure 16) in the **ON** position.

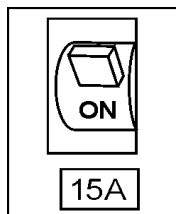

Figure 16. Main Circuit Breaker (ON)

- Read the voltmeter on the front panel of the generator (Figure 17) and verify that 120 VAC is present at the 120V twist-lock and GFCI duplex receptacles. For

additional verification of voltage, an external voltmeter can be used to measure the output voltage as shown in Figure 17.

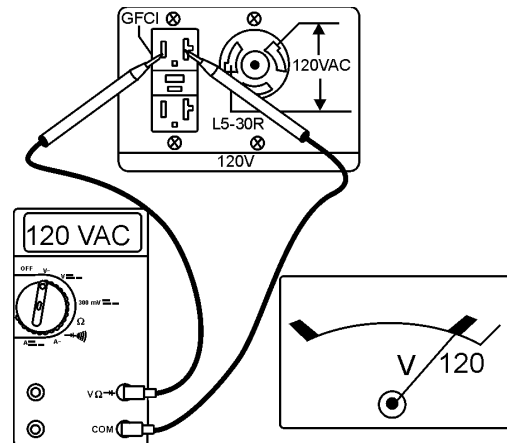

Figure 17. 120V/GFCI Receptacles

- Read the voltmeter on the front panel of the generator (Figure 18) and verify that 240 VAC is present at the 240V twist-lock receptacle. Using an external voltmeter verify that 240V is present at the 240V twist-lock receptacle.

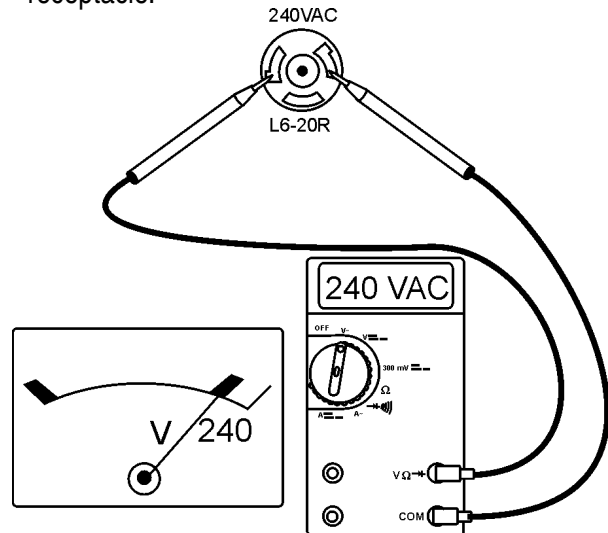

Figure 18. 240V Twist-Lock Receptacle

NOTICE

When using a combination of dual receptacles, total load should not exceed the rated capacity of the generator.

- Connecting of loads (power tools, lighting ect.) to the generator receptacles can now be done.

Stopping the Engine

1. Place the main circuit breaker (Figure 19) in the **OFF** position.

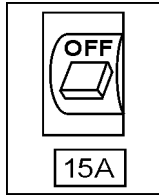

Figure 19. Main Circuit Breaker (OFF)

2. Place the idle control switch (Figure 20) in the **OFF** position.

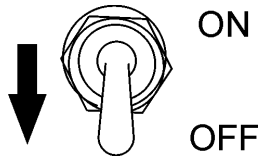

Figure 20. Idle Control switch (OFF)

3. Let the engine run at idle with no load for 2-3 minutes.
4. To shut-down the engine, place the generator's operation switch (Figure 21) in the **OFF** position.

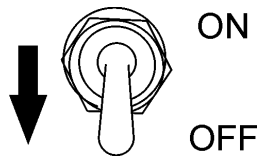

Figure 21. Operation Switch (OFF)

5. Place the engine fuel valve lever (Figure 22) in the **OFF** position.

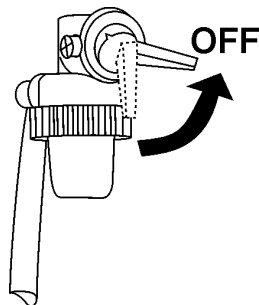

Figure 22. Engine Fuel Valve Lever (OFF)

6. Remove all loads from the generator.

Emergency Shutdown

PREPARATION FOR LONG TERM STORAGE

Generators Storage

For storage of the generating set for over 30 days, the following is required:

- Drain the fuel tank completely, or add STA-BIL to the fuel.
- Run the engine until the gasoline in the carburetor is completely consumed.
- Completely drain the oil from the crankcase and refill with fresh oil.
- Remove the spark plug, pour 2 or 3 cc of SAE 30 oil into the cylinder and crank slowly to distribute the oil.
- Slowly rotate the engine a few times with the starter rope and install a new plug.
- Pull out the starter rope slowly and stop at the compression point.
- Clean all external parts of the generating set with a cloth.
- Cover the generating set and store in a clean, dry place.

MAINTENANCE

Use Table 5 as a general maintenance guideline when servicing your engine. For more detail engine maintenance information, refer to the engine owner's manual supplied with your engine.

Table 5. Engine Maintenance Schedule							
DESCRIPTION (3)	OPERATION	BEFORE	FIRST MONTH OR 10 HRS.	EVERY 3 MONTHS OR 25 HRS.	EVERY 6 MONTHS OR 50 HRS.	EVERY YEAR OR 100 HRS.	EVERY 2 YEARS OR 200 HRS.
Engine Oil	CHECK	X					
	CHANGE						
Air Cleaner	CHECK	X	X				
	CHANGE			X (1)			
All Nuts & Bolts	RETIGHTEN IF NECESSARY	X					
Spark Plug	CHANGE				X		
	REPLACE						X
Cooling Fins	CHECK				X		
Spark Arrester	CLEAN					X	
Fuel Tank	CLEAN					X	
Fuel Filter	CHECK					X	
Idle Speed	CHECK-ADJUST					X (2)	
Valve Clearance	CHECK-ADJUST						X (2)
Fuel lines	CHECK	Every 2 years, replace if necessary (2)					

(1) Service more frequently when used in **DUSTY** areas.

(2) These items should be serviced by your service dealer, unless you have the proper tools and are mechanically proficient. Refer to the HONDA Shop Manual for service procedures.

(3) For commercial use, log hours of operation to determine proper maintenance intervals.

Maintenance

Perform the scheduled maintenance procedures as defined by Table 5 and below:

Daily

- Thoroughly remove dirt and oil from the engine and control area. Clean or replace the air cleaner elements as necessary. Check and retighten all fasteners as necessary.

Weekly

- Remove the fuel filter cap and clean the inside of the fuel tank.
- Remove or clean the filter at the bottom of the tank.
- Remove and clean the spark plug (Figure 23), then adjust the spark gap to 0.024 ~0.028 inch (0.6~0.7 mm). This unit has electronic ignition, which requires no adjustments.

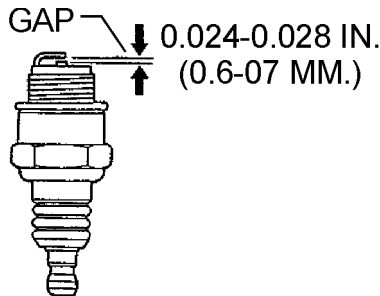

Figure 23. Spark Plug Gap

Engine Oil

1. Drain the engine oil when the oil is warm as shown in Figure 24.
2. Remove the oil drain bolt and sealing washer and allow the oil to drain into a suitable container.
3. Replace engine oil with recommended type oil as listed in Table 4. For engine oil capacity, see Table 2 (engine specifications). **DO NOT** overfill.
4. Install drain bolt with sealing washer and tighten securely.

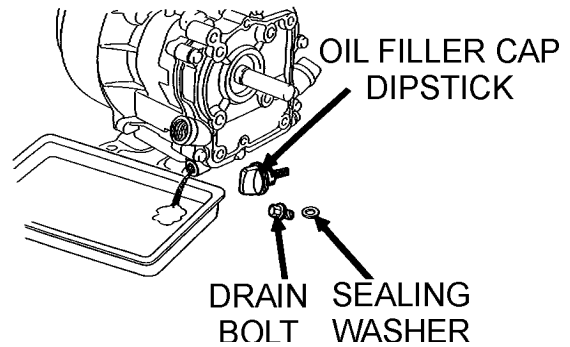

Figure 24. Draining Engine Oil

Engine Air Cleaner

1. Remove the air cleaner cover and foam filter element as shown in Figure 25.

⚠ DANGER

DO NOT use gasoline as a cleaning solvent, the possibility exists of fire or explosion which can cause damage to the equipment and severe bodily harm or even **DEATH!**

2. Clean foam element in warm, soapy water or nonflammable solvent. Rinse and dry thoroughly. Dip the element in clean engine oil and completely squeeze out the excess oil from the element before installing.

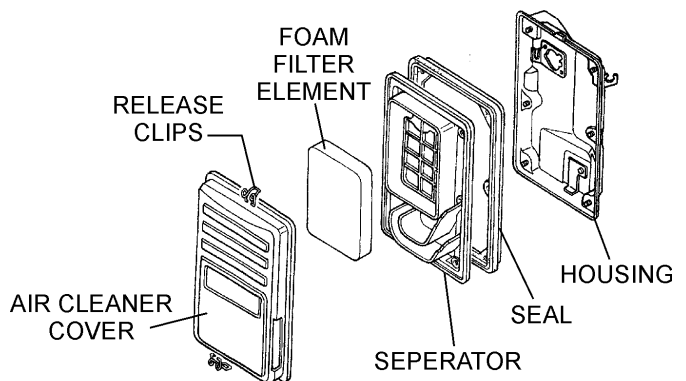
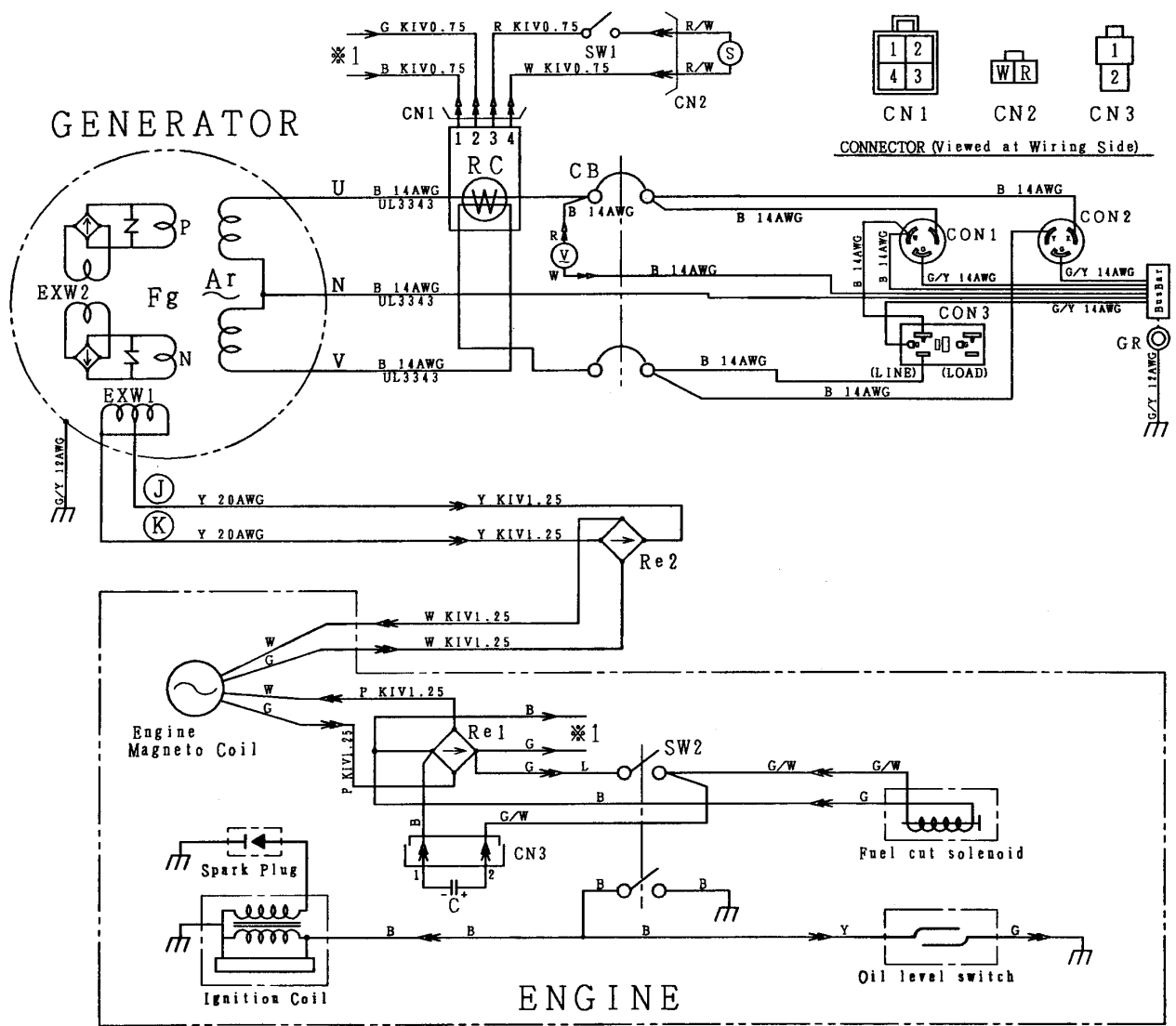

Figure 25. Engine Air Cleaner

GENERATOR WIRING DIAGRAM



SYMBOL	PART NAME
Ar	Armature Winding
Fg-PN	Field Winding
EXW1-2	Excitation Winding
V	AC Voltmeter (120/240)
Re1-2	Rectifier
CON1	Receptacle L5-30R
CON2	Receptacle L6-20R
CON3	Receptacle 5-15R
CB	UPM-2 20A
CB1	CP-31E/15N 15A
SW1	Idle Control Switch
SW2	Operation Switch
RC	Idle Control Device
S	Idle Control Solenoid
GR	Ground Terminal T-3830
C	Capacitor 50V @ 1000µf

Wiring Color Code			
Symbol	Color	Symbol	Color
B	BLACK	R	RED
L	BLUE	W	WHITE
BR	BROWN	Y	YELLOW
G	GREEN	LB	LIGHT BLUE
GR	GRAY	LG	LIGHT GREEN
V	VIOLET	O	ORANGE
P	PINK		

Figure 26. Generator Wiring Diagram

TROUBLESHOOTING

Table 6. Engine Troubleshooting

Symptom	Possible Cause	Solution
Difficult to start. Fuel is available but no SPARK at spark plug.	Spark plug bridging?	Check gap, insulation or replace spark plug.
	Carbon deposit on spark plug?	Clean or replace spark plug.
	Short circuit due to deficient spark plug insulation?	Check spark plug insulation. Replace if worn.
	Improper spark plug gap?	Set to proper gap.
Difficult to start. Fuel is available and SPARK is present at the spark plug.	ON/OFF switch is shorted?	Check switch wiring. Replace switch.
	Ignition coil defective?	Replace ignition coil.
	Improper spark gap, points dirty?	Set correct spark gap and clean points.
	Condenser insulation worn or short circuiting?	Replace condenser.
	Spark plug wire broken or short circuiting?	Replace defective spark plug wiring.
Difficult to start. Fuel is available, SPARK is present at the spark plug and compression is normal.	Wrong fuel type?	Flush fuel system and replace with correct type of fuel.
	Water or dust in fuel system?	Flush fuel system.
	Air cleaner dirty?	Clean or replace air cleaner.
Difficult to start. Fuel is available, SPARK is present at the spark plug and compression is low.	Suction/exhaust valve stuck or protruded?	Reseat valves.
	Piston ring and/or cylinder worn?	Replace piston rings or piston.
	Cylinder head and/or spark plug not tightened properly?	Torque cylinder head bolts and spark plug.
	Head gasket and/or spark plug gasket damaged?	Replace head and spark plug gaskets.
No fuel present at carburetor.	Fuel not available in fuel tank?	Fill with correct type of fuel.
	Fuel cock does not open properly?	Apply lubricant to loosen fuel cock lever. Replace if necessary.
	Fuel filter clogged?	Replace fuel filter.
	Fuel tank cap breather hole clogged?	Clean or replace fuel tank cap.
	Air in fuel line?	Bleed fuel line
Weak in power. Compression is proper and does not misfire.	Air cleaner dirty?	Clean or replace air cleaner.
	Improper level in carburetor?	Check float adjustment. Rebuild carburetor.
	Defective spark plug?	Clean or replace spark plug.

Table 6. Engine Troubleshooting (Continued)

Symptom	Possible Cause	Solution
Weak in power. Compression is proper but misfires.	Water in fuel system?	Flush fuel system and replace with correct type of fuel.
	Dirty spark plug?	Clean or replace spark plug
	Ignition coil defective?	Replace ignition coil.
Engine overheats.	Spark plug heat value improper?	Replace with correct type of spark plug.
	Incorrect type of fuel?	Replace with correct type of fuel.
	Cooling fins dirty?	Clean cooling fins.
Rotational speed fluctuates.	Governor adjusted correctly?	Adjust governor
	Governor spring defective?	Replace governor spring.
	Fuel flow restricted?	Check entire fuel system for leaks or clogs.
Recoil starter malfunction.	Recoil mechanism clogged with dust and dirt?	Clean recoil assembly with soap and water.
	Spiral spring loose?	Replace spiral spring.

TROUBLESHOOTING

Table 7. Generator Troubleshooting

Symptom	Possible Problem	Solution
Low voltage	Engine speed too low?	Raise engine speed to rated RPM.
Low voltage. Engine speed normal 3650 RPM (unloaded), 2500 RPM (idle)	AC voltmeter not working?	Replace Ac voltmeter.
	Control box internal wiring malfunction?	Check control box wiring.
	Defective ignition coil?	Check red and green ignition wires. Replace ignition wires if necessary.
	Rotor winding malfunction?	Check or replace rotor.
	Stator winding malfunction?	Check or replace stator.
	Leakage breaker malfunction?	Check or replace CB1.
	Full power switch malfunction?	Check full power switch and full power switch circuit.
Voltage output too high.	Engine speed too high?	Lower engine speed to rated RPM.
Voltage output too high. Engine speed normal 3650 RPM (unloaded), 2500 RPM (idle)	Control box internal wiring malfunction	Check control box wiring.
Circuit breaker will not turn on "NO LOAD"	Defective circuit breaker?	Replace circuit breaker.
Circuit breaker will turn on "LOADED" but trips immediately.	Overload Condition?	Reduce load or replace breaker.
	Load circuit is shorted?	Check load circuit for short.
Does not accelerate from low to high "NO LOAD"	Stuck solenoid?	Check solenoid.
	Bad Idle control switch?	Check or replace idle control switch.
Does not accelerate from low to high "LOAD ACTIVE"	Idle control switch malfunction?	Check or replace idle control switch.
	Idle control device malfunction?	Check or replace idle control device.
	Control box internal wiring defective?	Check control box wiring.
Does not decelerate no "VOLTAGE OUTPUT".	Defective rotor windings?	Check or replace rotor.
	Defective solenoid?	Check or replace solenoid.
	Defective idle control device?	Check or replace idle control device.
	Defective solenoid?	Check or replace idle control device.
Does not decelerate but has "VOLTAGE OUTPUT".	Control box wiring malfunction?	Check control box wiring, replace any defective components.
	Defective solenoid?	Check or replace solenoid.
	Idle control device malfunction?	Check or replace idle control device.

EXPLANATION OF CODE IN REMARKS COLUMN

The following section explains the different symbols and remarks used in the Parts section of this manual. Use the help numbers found on the back page of the manual if there are any questions.

NOTICE

The contents and part numbers listed in the parts section are subject to change **without notice**. Multiquip does not guarantee the availability of the parts listed.

SAMPLE PARTS LIST

NO.	PART NO.	PART NAME	QTY.	REMARKS
1	12345	BOLT.....	1	INCLUDES ITEMS W/%
2%		WASHER, 1/4 IN.....		NOT SOLD SEPARATELY
2%	12347	WASHER, 3/8 IN....	1	MQ-45T ONLY
3	12348	HOSE	A/R	MAKE LOCALLY
4	12349	BEARING	1	S/N 2345B AND ABOVE

NO. Column

Unique Symbols — All items with same unique symbol

(@, #, +, %, or >) in the number column belong to the same assembly or kit, which is indicated by a note in the “Remarks” column.

Duplicate Item Numbers — Duplicate numbers indicate multiple part numbers, which are in effect for the same general item, such as different size saw blade guards in use or a part that has been updated on newer versions of the same machine.

NOTICE

When ordering a part that has more than one item number listed, check the remarks column for help in determining the proper part to order.

PART NO. Column

Numbers Used — Part numbers can be indicated by a number, a blank entry, or TBD.

TBD (To Be Determined) is generally used to show a part that has not been assigned a formal part number at the time of publication.

A blank entry generally indicates that the item is not sold separately or is not sold by Multiquip. Other entries will be clarified in the “Remarks” Column.

QTY. Column

Numbers Used — Item quantity can be indicated by a number, a blank entry, or A/R.

A/R (As Required) is generally used for hoses or other parts that are sold in bulk and cut to length.

A blank entry generally indicates that the item is not sold separately. Other entries will be clarified in the “Remarks” Column.

REMARKS Column

Some of the most common notes found in the “Remarks” Column are listed below. Other additional notes needed to describe the item can also be shown.

Assembly/Kit — All items on the parts list with the same unique symbol will be included when this item is purchased.

Indicated by:

“INCLUDES ITEMS W/(unique symbol)”

Serial Number Break — Used to list an effective serial number range where a particular part is used.

Indicated by:

“S/N XXXXX AND BELOW”

“S/N XXXX AND ABOVE”

“S/N XXXX TO S/N XXX”

Specific Model Number Use — Indicates that the part is used only with the specific model number or model number variant listed. It can also be used to show a part is NOT used on a specific model or model number variant.

Indicated by:

“XXXXX ONLY”

“NOT USED ON XXXX”

“Make/Obtain Locally” — Indicates that the part can be purchased at any hardware shop or made out of available items. Examples include battery cables, shims, and certain washers and nuts.

“Not Sold Separately” — Indicates that an item cannot be purchased as a separate item and is either part of an assembly/kit that can be purchased, or is not available for sale through Multiquip.

SUGGESTED SPARE PARTS

GAC3.6HZ PORTABLE 60 HZ GENERATOR WITH HONDA GX240K1EDN2/GX240U1EDN2 GASOLINE ENGINES

1 to 3 units

Qty.	P/N	Description
10810106004.....	CAP FUEL TANK
10810107103.....	FILTER FUEL
17895419004.....	RUBBER SUSPENSION
41725419214.....	RUBBER SUSPENSION
39807955846.....	SPARK PLUG
1◆15510ZE2043.....	SWITCH ASSY., OIL ALERT
1◇15510ZE2053.....	SWITCH ASSY., OIL ALERT
228462ZE2W11.....	ROPE, RECOIL
317211899000.....	ELEMENT AIR CLEANER

NOTICE

Part numbers on this Suggested Spare Parts list may supersede/replace the part numbers shown in the following parts lists.



- ◆GX240K1EDN2: Model GAC3.6HZ, SEPTEMBER 2007 AND BELOW
- ◇GX160U1EDN2: Model GAC3.6HZ, JANUARY 2008 AND ABOVE

NAMEPLATE AND DECALS

S/N 5561008 AND BELOW

1 **CAUTION**
Do not use in rain or snow.
ATTENTION
Ne pas utiliser en cas de pluie ou de neige.

7 FUEL COOK ROCKET D'ESSAI ON/OFF OFF/FERMER

2 **CAUTION/ATTENTION**
HOT PARTS can burn skin.
• DO NOT touch until the lamp has sufficiently cooled.
Danger de brûlure, pièces chaudes.
• Ne touchez pas avant que l'appareil ne soit suffisamment refroidi.

3 **WARNING/ATTENTION**
• Only operate machine in well ventilated areas.
• Do not inhale exhaust gases.
• Utilisez l'équipement que dans des endroits bien aérés.
• Ne respirez pas les gaz d'échappement.
Dangerous Conditions / Conditions dangereuses
Only qualified personnel should install, use or service this equipment.
Seul un personnel qualifié devrait installer, utiliser ou entretenir cet équipement.

4 **DANGER**
• Do not touch output terminals or internal wiring while unit is operating.
• Turn off power before servicing.
• Be watched in the territory exterior to the cable electrical system lorsque que l'équipement est en opération.
• Éloignez-vous avant de réparer.
Only qualified personnel should install, use, or service this equipment.
Seul un personnel qualifié devrait installer, utiliser ou entretenir cet équipement.

6 **CAUTION**
• READ OWNER'S SERVICE MANUAL BEFORE OPERATING OR SERVICING THIS MACHINE.
• ALWAYS KEEP UNAUTHORIZED INEXPERIENCED UNTRAINED PEOPLE AWAY FROM THIS MACHINE.
• MAKE SURE ALL SAFETY DEVICES ARE OPERATIONAL BEFORE THIS MACHINE IS STARTED. MAKE SURE ENGINE IS TURNED OFF AND SPARK PLUG WIRE DISCONNECTED BEFORE SERVICING THE MACHINE OR COMING IN CONTACT WITH ANY MOVING PART. IF EQUIPMENT IS POWERED BY AN ELECTRIC MOTOR, DISCONNECT ELECTRICAL PLUG.
• NEVER LEAVE MACHINE UNATTENDED WHEN OPERATING ALWAYS STOP ENGINE AND ALLOW ENGINE TO COOL BEFORE ADDING FUEL OR OIL.

5 **CAUTION**
• Il est impératif de lire le manuel d'utilisation, avant d'utiliser ou de réparer cet équipement.
• Il est impératif de garder tout personnel non autorisé ou non qualifié à distance de cet équipement.
• Assurez vous que tout équipement de sécurité est fonctionnel avant d'engager l'équipement. Assurez vous que le moteur est éteint et que le fil de la bougie est déconnecté avant de réparer la machine ou avant tout contact avec toute pièce en mouvement. Si l'équipement est alimenté par un moteur électrique débranchez l'appareil.
• Ne laissez jamais l'appareil sans supervision quand il est en marche. Il est impératif d'arrêter le moteur et de le laisser refroidir avant d'ajouter de l'huile ou du carburant.

8 **MULTIQUIP 3600**

10 Insulation System --- B
Maximum ambient Temperature --- 40°C (104°F)
Système d'insulation --- B
Température ambiante maximum --- 40°C (104°F)

S/N 5561009~5582082

11 **DANGER**
NEVER use in enclosed or partially enclosed areas.
NEVER use outdoors and away from open windows, doors, and vents.
Utilisation INTERDITE dans un espace clos ou partiellement clos.
NE PAS utiliser à l'extérieur et loin des fenêtres, portes, et ventilateurs.
Utilisation UNIQUEMENT à l'extérieur et loin des ouvertures.

S/N 5582083~ 5622593

12 **DANGER**
Using a generator indoors CAN KILL YOU IN MINUTES.
Utiliser un générateur à l'intérieur POUVRA EN TUEZ EN QUELQUES MINUTES.
Exhaust contains carbon monoxide, a poison gas you cannot see or smell.
Les gaz d'échappement contiennent du monoxyde de carbone, un gaz toxique invisible et inodore.
NEVER use in enclosed or partially enclosed areas.
NEVER use outdoors and away from open windows, doors, and vents.
Utilisation INTERDITE dans un espace clos ou partiellement clos.
NE PAS utiliser à l'extérieur et loin des fenêtres, portes, et ventilateurs.
Utilisation UNIQUEMENT à l'extérieur et loin des ouvertures.

S/N 5622594 AND ABOVE

13 **WARNING**
Operation of this equipment may create sparks that can start fires around dry vegetation.
A spark arrestor may be required.
The operator should contact local fire agencies for laws or regulation relating to fire prevention requirements.
Des étincelles pouvant enflammer la végétation sèche environnante peuvent être produites pendant le fonctionnement de cet équipement.
Un pare-étincelles peut être requis.
L'opérateur doit contacter les agences anti-incendie locales pour s'informer des lois ou réglementations concernant les exigences de prévention-incendie.

NAMEPLATE AND DECALS

NO.	PART NO.	PART NAME	QTY.	REMARKS
1	A3552000004A	DECAL; CAUTION, RAIN SNOW.....	1.....	A35200000A
2	A6552000404A	DECAL; CAUTION, HOT PARTS	1.....	A65300040A
3	A6532100904A	DECAL; WARNING, EXHAUST GASES	1.....	A63210090A
4	A6532101004A	DECAL; DANGER, ELECTROCUTION	1.....	A63210100A
5	A5552000804	DECAL; OPERATING INSTR. (FRENCH).....	1.....	A552200080
6	A5552000704A	DECAL; OPERATING INSTR. (ENGLISH).....	1.....	A55200070A
7	A9508200004	DECAL; FUEL COCK.....	1.....	A90820000
8	W7910631002	DECAL; MQ LOGO 3600 STRIPE.....	1.....	S-3753
10	A3532100304A	DECAL; SPECIFICATION	1.....	A33210030A
11	A9511100204	DECAL; DANGER, GROUND ROD	1.....	A91110020
			S/N 5561009~5582082
12	A9504000104	DECAL; DANGER, DANGEROUS GASES.....	1.....	A90400010
			S/N 5582083~5622593
13	A9504000204	DECAL; WARNING, SPARK ARRESTOR.....	1.....	A90400020
			S/N 5622594 AND ABOVE

GENERATOR ASSY.

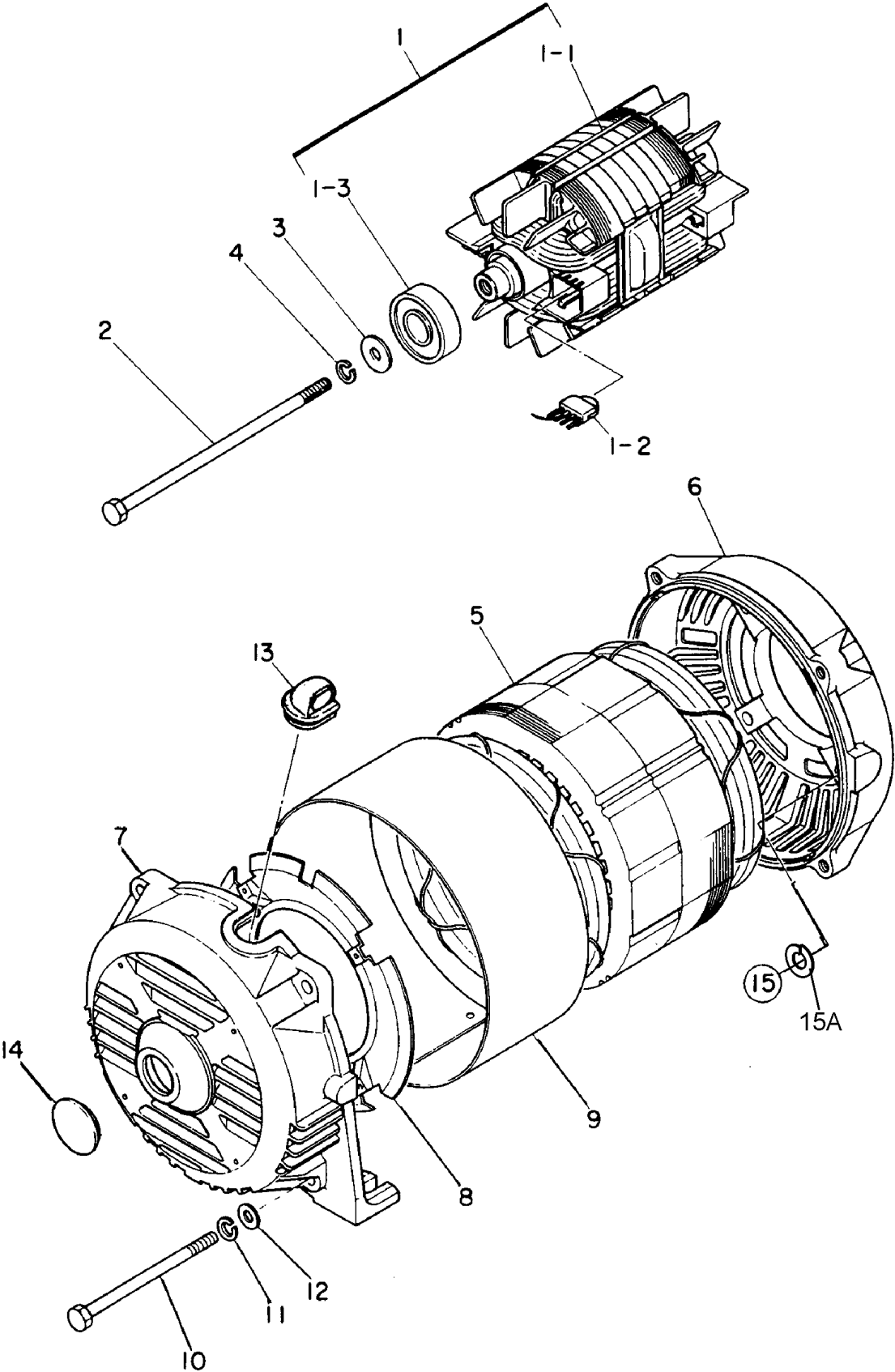

GENERATOR ASSY.

<u>NO.</u>	<u>PART NO.</u>	<u>PART NAME</u>	<u>QTY.</u>	<u>REMARKS</u>
1	7911000203	ROTOR ASS;Y	1	
1-1	7661080003	FIELD COIL	1	
1-2	0601823213	RECTIFIER, D3SB80	2	
	0601822637	SURGE ABSORBER	2	
1-3	0771017004	BEARING	1	
2	7911017004	SET BOLT, ROTOR	1	
3	0801086104	SET WASHER, BEARING	1	
4	0040010000	WASHER, LOCK	1	
5	A3136000103	ARMATURE ASS'Y	1	
6	7901315502	END BRACKET	1	
7	7871315022	END BRACKET	1	
8	7875021523	GUIDE PANEL, AIR	1	
9	7661331003	COVER	1	
10	7911316004	SET BOLT, STATOR	4	
11	0040008000	WASHER, LOCK	4	
12	0041208000	WASHER, FLAT	4	
13	7871329514	GROMMET	1	
14	0601851760	CAP	1	
15	0010108020	HEX. HEAD BOLT	4	
15A	0040008000	WASHER, LOCK	4	

CONTROL BOX ASSY.

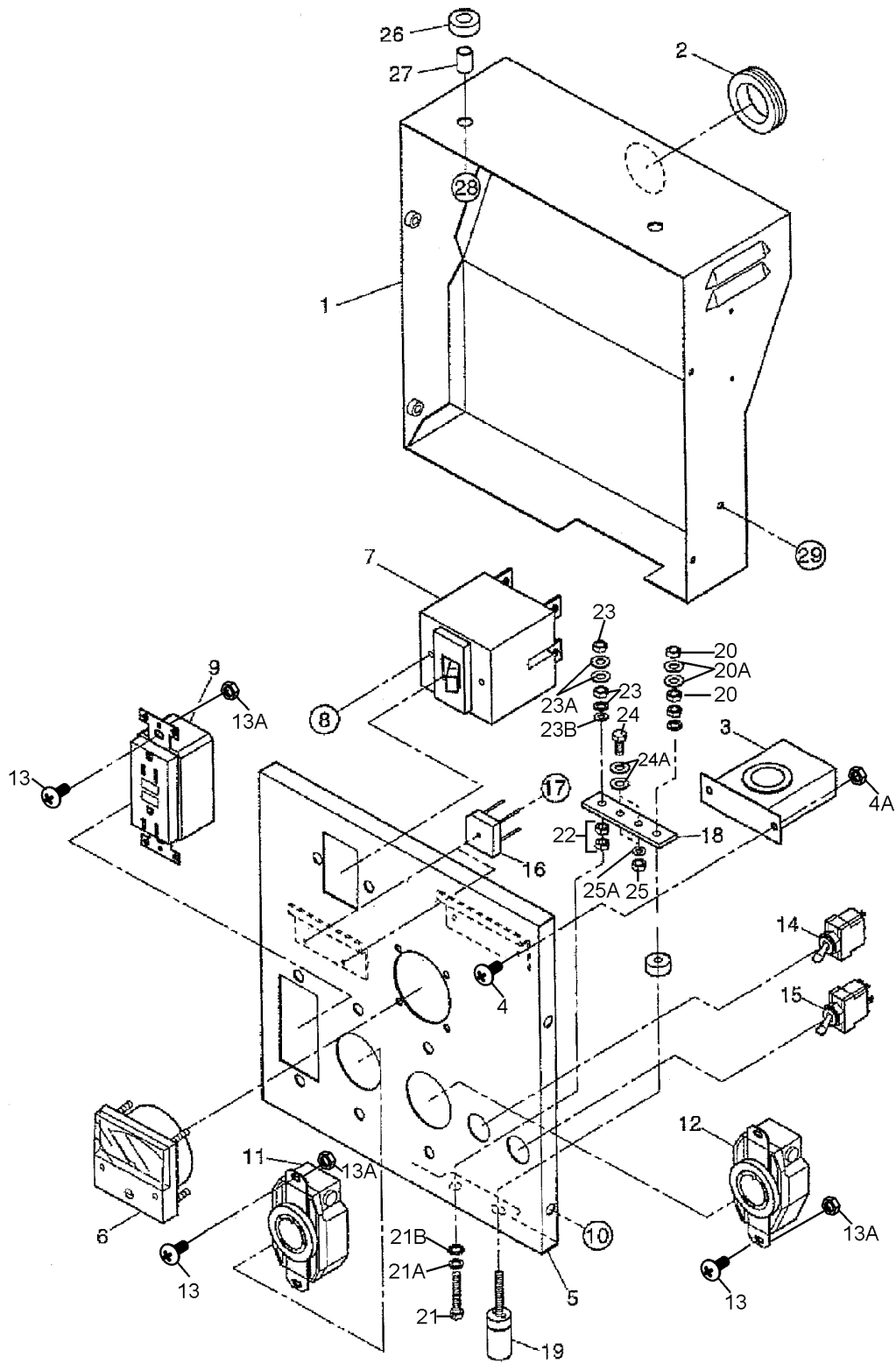

CONTROL BOX ASSY.

<u>NO.</u>	<u>PART NO.</u>	<u>PART NAME</u>	<u>QTY.</u>	<u>REMARKS</u>
1	A3215000103	CONTROL BOX	1	
2	0601850102	GROMMET	1	
3	0601823853	SLOW DOWN UNIT	1	
4	0027104010	MACHINE SCREW	2	
4A	0207004010	HEX. NUT	2	
5	A3225000303A	CONTROL PANEL	1	
6	0601806819	AC VOLTMETER, DE450 120V 0-240V	1	
7	0601807463	CIRCUIT BREAKER, 15A	1	
8	0027104010	MACHINE SCREW	2	
9	0601812590	RECEPTACLE, 5-15R,GF5252 (GFCI)	1	
10	0027105010	MACHINE SCREW	2	
11	0601811035	RECEPTACLE, L5-30R:125V,30A	1	
12	0601811032	RECEPTACLE, L6-20R:250V,20A	1	
13	0027104010	MACHINE SCREW	6	
13A	0207004000	HEX. NUT	6	
14	0601830727	IDLE CONTROL SWITCH	1	
15	0601830738	OPERATION SWITCH	1	
16	0601823204	RECTIFIER	2	
17	0027103020	MACHINE SCREW	2	
18	A3262800104	TERMINAL PLATE	1	
19	0601815147	GROUND TERMINAL	1	
20	0207005000	HEX. NUT	2	
20A	0041205000	WASHER, FLAT	1	
21	0012905040	HEX. HEAD BOLT	1	
21A	0040005000	WASHER, LOCK	1	
21B	0040505000	WASHER, STAR TOOTH	1	
22	0207005000	HEX. NUT	2	
23	0207005000	HEX. NUT	2	
23A	0041205000	WASHER, FLAT	1	
23B	0040005000	WASHER, SPRING	1	
24	0012905020	HEX. HEAD BOLT	2	
24A	0041205000	WASHER, FLAT	4	
25	0207005000	HEX. NUT	2	
25A	0040005000	WASHER, LOCK	2	
26	0805088004	RUBBER CUSHION	2	
27	0805088304	COLLAR	2	
28	0017106020	HEX. HEAD BOLT	2	
29	0017106016	HEX. HEAD BOLT	1	

PIPE FRAME ASSY.

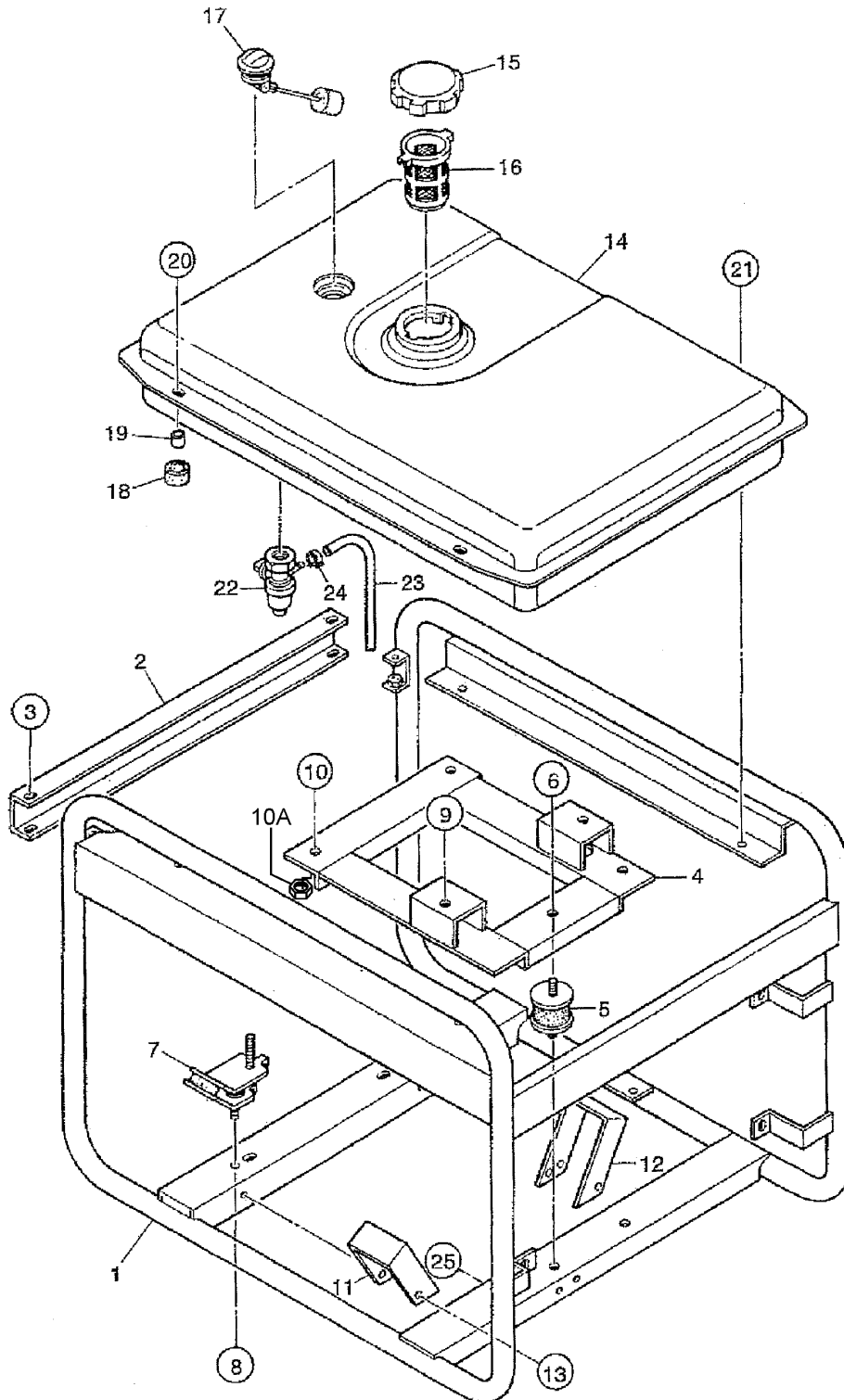

PIPE FRAME ASSY.

<u>NO.</u>	<u>PART NO.</u>	<u>PART NAME</u>	<u>QTY.</u>	<u>REMARKS</u>
1	A3418000003	PIPE FRAME	1	
2	7915415004	BRACKET	1	
3	0017106016	HEX. HEAD BOLT	4	
4	7915443003	BASE	1	
5	7895419004	RUBBER SUSPENSION	2	
6	0207008000	HEX. NUT	4	
7	1725419214	RUBBER SUSPENSION	2	
8	0207008000	HEX. NUT	4	
9	0017108040	HEX. HEAD BOLT	2	
10	0017108040	HEX. HEAD BOLT	2	
10A	0207008000	HEX. NUT	2	
11	7915455103	COVER	1	
12	7915455003	COVER	1	
13	0017106016	HEX. HEAD BOLT	6	
14	7905512002	FUEL TANK	1	
15	0810106004	CAP, FUEL TANK	1	
16	0810107103	FUEL FILTER	1	
17	0602125034	FUEL GAUGE	1	
18	7855525514	RUBBER CUSHION	2	
19	7855525604	GCOLLAR	2	
20	0017108030	HEX. HEAD BOLT	2	
21	0017108020	HEX. HEAD BOLT	2	
22	16950ZB4015	FUEL COCK	1.....	REPLACES P/N 0605511087
23	950014519040	HOSE.....	1.....	REPLACES P/N 0605513140
24	0605515096	HOSE BAND	2	
25	0019106015	HEX. HEAD BOLT	1	

MUFFLER ASSY.

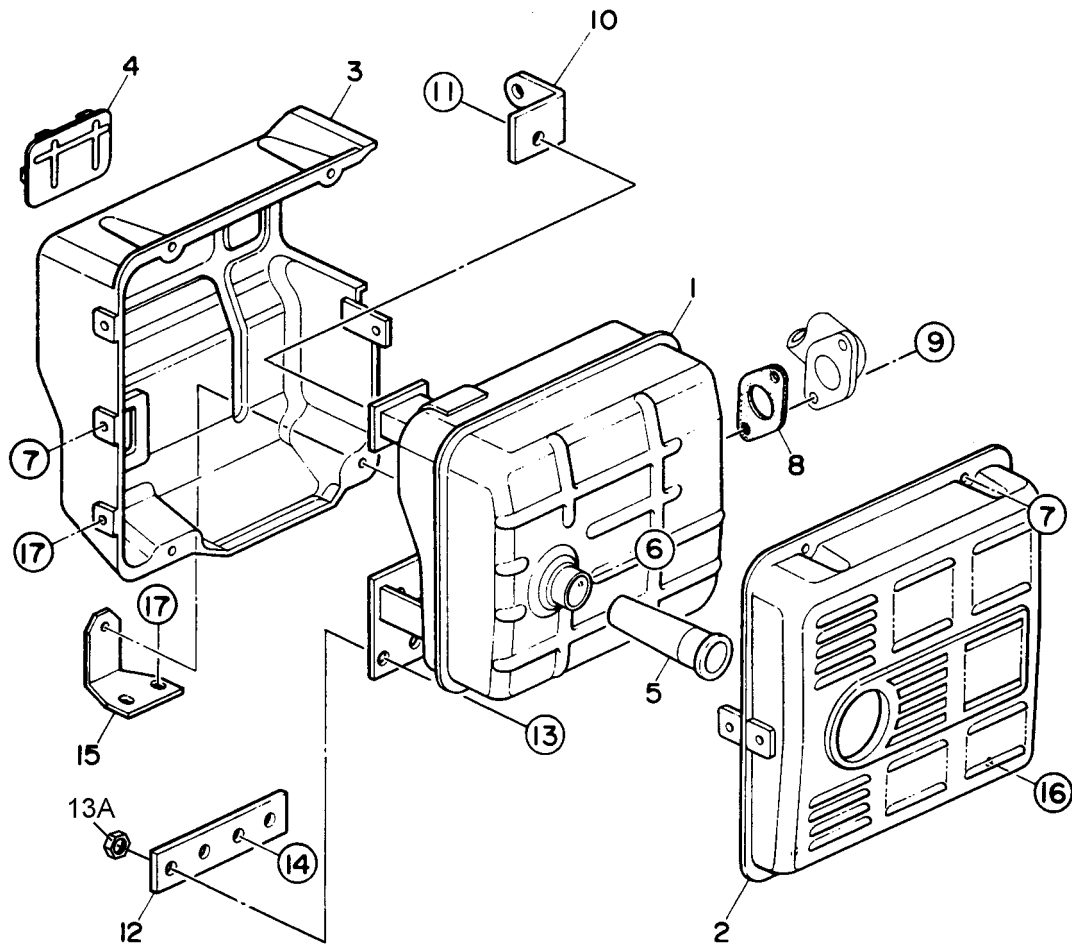

MUFFLER ASSY.

<u>NO.</u>	<u>PART NO.</u>	<u>PART NAME</u>	<u>QTY.</u>	<u>REMARKS</u>
1	7912310003	MUFFLER	1	
2	18320ZB4000	PROTECTOR, MUFFLER.....	1.....	REPLACES P/N 0602302000
3	18325ZB4000	PROTECTOR, MUFFLER.....	1.....	REPLACES P/N 0602302002
4	18329ZB4000	SEAL	2	REPLACES P/N 0602302003
5	18355ZB4630	ARRESTER, SPARK.....	1.....	REPLACES P/N 0602322060
6	90183671003	TAPPING SCREW	1	
7	0017106012	HEX. HEAD BOLT	5	
8	18333ZB4800	GASKET	1.....	REPLACES P/N 0602320175
9	957000802000	HEX. HEAD BOLT	2.....	REPLACES P/N 0602322061
10	7915461004	BRACKET	1	
11	0017108020	HEX. HEAD BOLT	1	
12	7915460004	BRACKET	1	
13	0017108025	HEX. HEAD BOLT	2	
13A	0207008000	HEX. NUT	2	
14	0017108020	HEX. HEAD BOLT	2	
15	7915469004	BRACKET	1	
16	0017106020	HEX. HEAD BOLT	1	
17	0017106012	HEX. HEAD BOLT	2	

HONDA GX240K1/U1EDN2 ENGINE — CYLINDER HEAD ASSY.

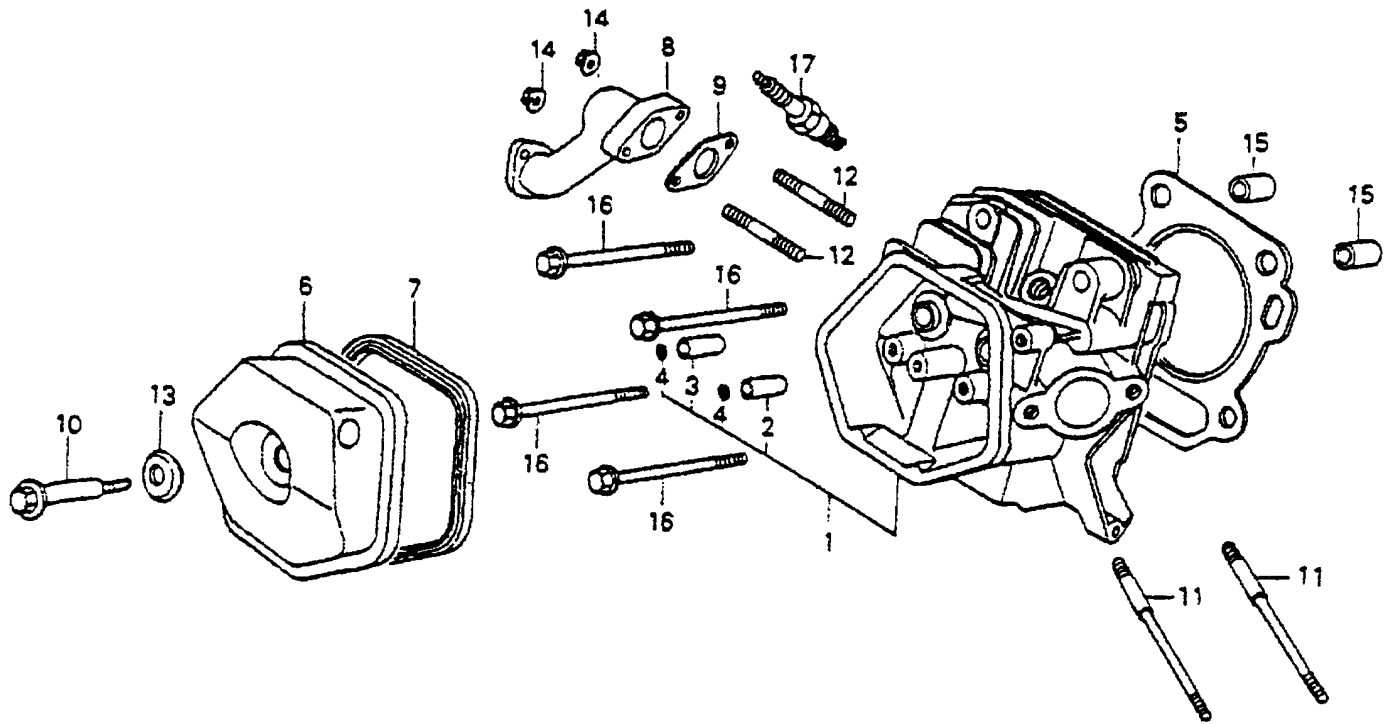

HONDA GX240K1/U1EDN2 ENGINE — CYLINDER HEAD ASSY.

<u>NO.</u>	<u>PART NO.</u>	<u>PART NAME</u>	<u>QTY.</u>	<u>REMARKS</u>
1◆	12200ZH9000	HEAD COMP., CYLNDER	1	
1◇	12200ZH9405	HEAD COMP., CYLNDER	1	
2	12204ZE2306	GUIDE, IN. VALVE (OVER SIZE)	1	
3	12205ZE2305	GUIDE, EX. VALVE (OVER SIZE)	1	
4	12216ZE2300	CLIP, VALVE GUIDE	1	
5	12251ZE2800	GASKET, CYLINDER HEAD	1	
6	12310ZE2020	COVER COMP., HEAD	1	
7	12391ZE2020	PACKING, HEAD COVER	1	
8◆	18330ZE3700	PIPE, EX.	1	
9◆	18333ZE3800	GASKET, EX. PIPE	1	
10	90014ZE2000	BOLT, HEAD COVER	1	
11	90042ZE2700	BOLT, STUD, 8X98	2	
12	92900080320E	BOLT, STUD, 8X47	2	
13	90441ZE2010	WASHER COMP., HEAD COVER	1	
14	9405008000	NUT, FLANGE, 8MM	2	
15	9430112200	PIN, DOWEL, 12X20	2	
16◆	957251008000	BOLT, FLANGE, 10X80	4	
16◇	957251008000	BOLT, FLANGE, 10X80.....	4.....	USE UP TO S/N 1167470
16◇	957011008000	BOLT, FLANGE, 10X80.....	4.....	USE FROM S/N 1167471
17	9807955846	PLUG, SPARK (BPR5ES NGK)	1	
17	9807955855	PLUG, SPARK (W16EPR-U ND)	1	
18◆	14775ZE2010	SEAT, VALVE SPRING	1	

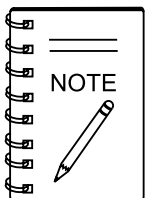

- ◆GX240K1EDN2: Model GAC3.6HZ, SEPTEMBER 2007 AND BELOW
- ◇GX160U1EDN2: Model GAC3.6HZ, JANUARY 2008 AND ABOVE

HONDA GX240K1/U1EDN2 ENGINE — CYLINDER BARREL ASSY.

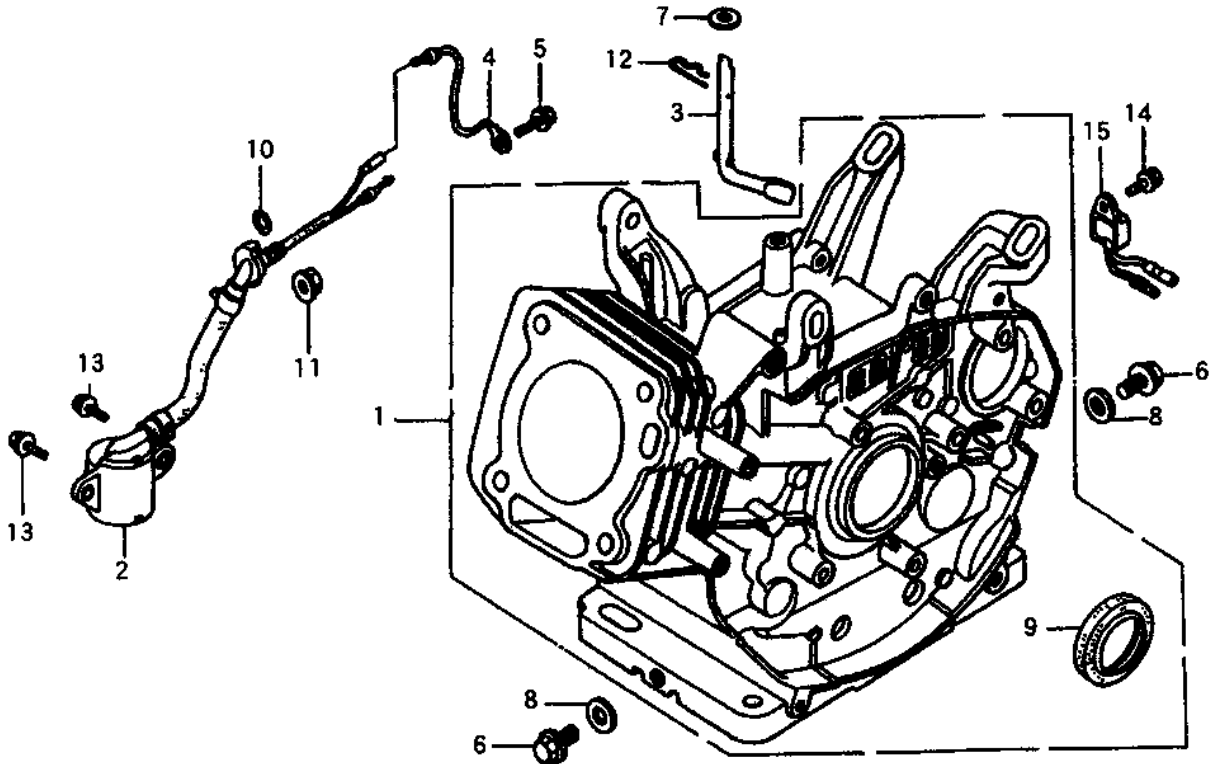

HONDA GX240K1/U1EDN2 ENGINE — CYLINDER BARREL ASSY.

NO.	PART NO.	PART NAME	QTY.	REMARKS
1◆	12000ZE2815	BARREL ASSY., CYLINDER	1.....	INCLUDES ITEM W/#
1◇	15510ZE2406	BARREL ASSY., CYLINDER	1	
2◆	15510ZE2043	SWITCH ASSY., OIL LEVEL	1	
2◇	15510ZE2043	SWITCH ASSY., OIL LEVEL.....	1.....	USE UP TO S/N 1174359
2◇	15510ZE2053	SWITCH ASSY., OIL LEVEL.....	1.....	USE FROM S/N 1174360
3	16541ZE2010	SHAFT, GOVERNOR ARM	1	
4	31161ZE2000	CORD, EARTH	1	
5	90013883000	BOLT, FLANGE 6X12	1	
6	90131883000	BOLT, DRAIN PLUG	2	
7	90446KE1000	WASHER, 8.2X17X0.8	1	
8	9410912000	WASHER, DRAIN PLUG	2	
9#	91201890003	OIL SEAL	1	
10	91353671004	O-RING, 14MM	1	
11	9405010000	NUT, FLANGE, 10MM	1	
12	9425108000	PIN, LOCK, 8MM	1	
13	957010601200	BOLT, FLANGE, 6X12	2	
14	90013883000	BOLT, FLANGE, 6X12	1	
15◆	34150ZH7003	ALERT UNIT, OIL	1	
15◇	34150ZH7003	ALERT UNIT, OIL.....	1.....	USE UP TO S/N 1178305
15◇	34150ZH7013	ALERT UNIT, OIL.....	1.....	USE FROM S/N 1178306

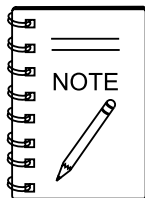

◆GX240K1EDN2: Model GAC3.6HZ, SEPTEMBER 2007 AND BELOW

◇GX160U1EDN2: Model GAC3.6HZ, JANUARY 2008 AND ABOVE

HONDA GX240K1/U1EDN2 ENGINE — CRANKCASE CVR. ASSY.

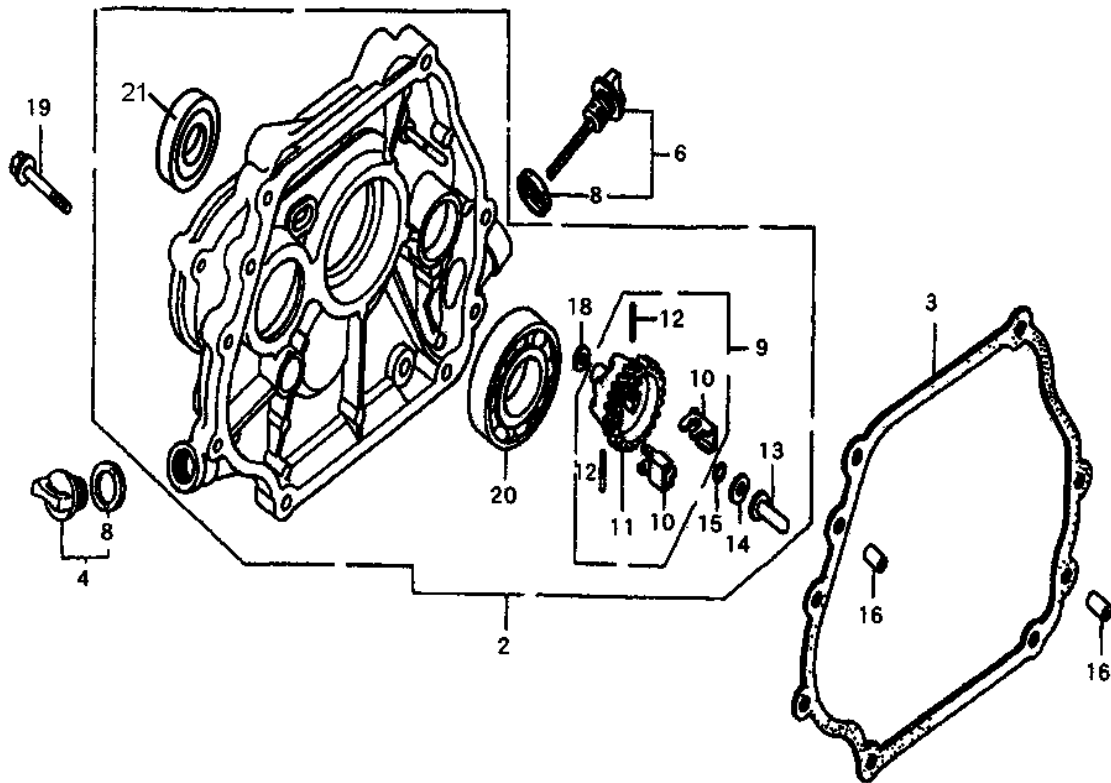

HONDA GX240K1/U1EDN2 ENGINE — CRANKCASE CVR. ASSY.

NO.	PART NO.	PART NAME	QTY.	REMARKS
2◆	11300ZE2000	COVER ASSY., CRANKCASE	1.....	INCLUDES ITEMS W/#
2◇	11300ZE2020	COVER ASSY., CRANKCASE	1.....	INCLUDES ITEMS W/#
3	11381ZE2801	PACKING, CASE COVER	1	
4	15600ZG4003	CAP ASSY., OIL FILLER.....	1.....	INCLUDES ITEMS W/\$
6	15600735003	CAP ASSY., OIL FILLER.....	1.....	INCLUDES ITEMS W/%
8%\$	15625ZE1000	PACKING, OIL FILLER CAP	1	
9#	16510ZE2000	GOVERNOR ASSY.	1.....	INCLUDES ITEMS W/<
10#<	16511ZE2000	WEIGHT, GOVERNOR	2	
11#<	16512ZE2000	HOLDER, GOVERNOR WEIGHT	1	
12#<	16513ZE2000	PIN, GOVERNOR WEIGHT	2	
13◆#	16531ZE2000	SLIDER, GOVERNOR	1	
13◇#	16531Z0A000	SLIDER, GOVERNOR	1	
14◆	90473147000	WASHER, 6X16	1	
15#	90602ZE1000	CLIP, GOVERNOR HOLDER	1	
16	90701HC4000	PIN, DOWEL, 8X12	2	
18#	9410106800	WASHER, PLAIN, 6MM	1	
19	957010803500	BOLT, FLANGE, 8X35	1	
20#	961006206000	BEARING, RADIAL BALL 6206	1	
21◇#	91201890003	OIL SEAL, 30X46X8	1	



◆GX240K1EDN2: Model GAC3.6HZ, SEPTEMBER 2007 AND BELOW

◇GX160U1EDN2: Model GAC3.6HZ, JANUARY 2008 AND ABOVE

HONDA GX240K1/U1EDN2 ENGINE — CRANKSHAFT ASSY.

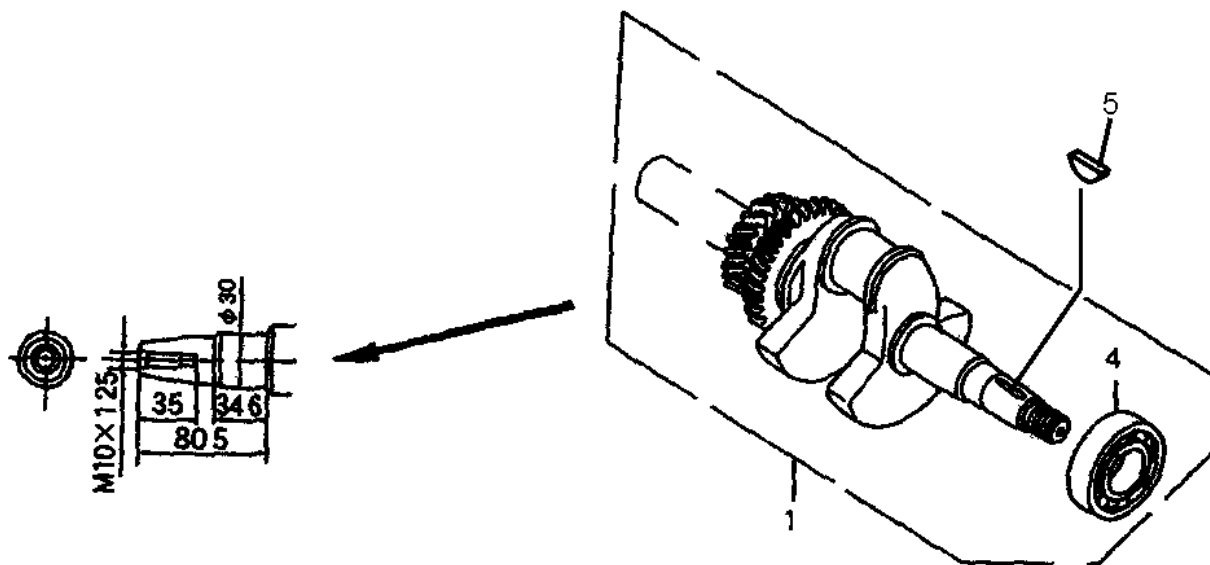

HONDA GX240K1/U1EDN2 ENGINE — CRANKSHAFT ASSY.

<u>NO.</u>	<u>PART NO.</u>	<u>PART NAME</u>	<u>QTY.</u>	<u>REMARKS</u>
1◆	13310ZE2701	CRANKSHAFT COMP.....	1.....	INCLUDES ITEM W/#
1◇	13310ZE2701	CRANKSHAFT COMP.....	1.....	INCLUDES ITEM W/#
1◇	13310ZE2702	CRANKSHAFT COMP.....	1.....	INCLUDES ITEM W/#
4#	961006206000	BEARING, RADIAL BALL, 6206	1	
5◇	90741ZE2000	KEY SPECIAL, WOODRUFF, 25X18	1	

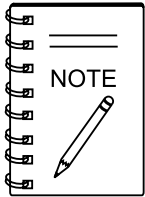

- ◆GX240K1EDN2: Model GAC3.6HZ, SEPTEMBER 2007 AND BELOW
- ◇GX160U1EDN2: Model GAC3.6HZ, JANUARY 2008 AND ABOVE

HONDA GX240K1/U1EDN2 ENGINE — PISTON ASSY.

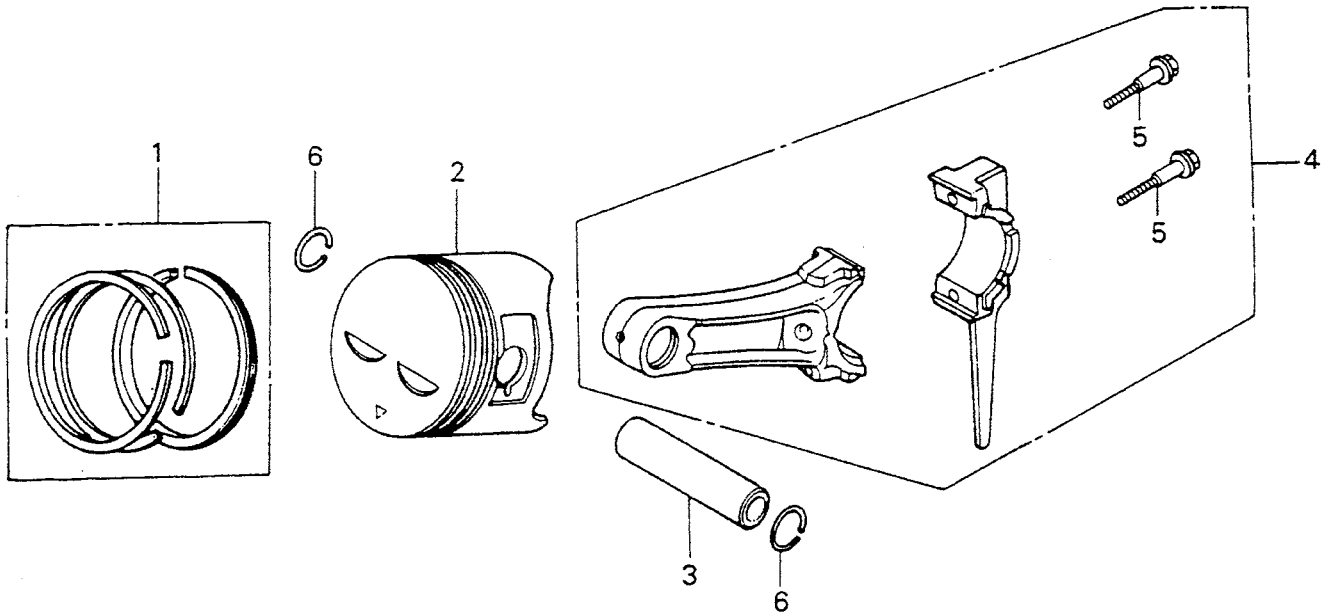

HONDA GX240K1/U1EDN2 ENGINE — PISTON ASSY.

<u>NO.</u>	<u>PART NO.</u>	<u>PART NAME</u>	<u>QTY.</u>	<u>REMARKS</u>
1	13020ZE2921	RING SET, PISTON (STD)	1	
1	13010ZE2922	RING SET, PISTON (STD)	1	
1	13011ZE2921	RING SET, PISTON (0.25)	1	
1	13011ZE2922	RING SET, PISTON (0.25)	1	
1	13012ZE2013	RING SET, PISTON (0.50)	1	
1	13012ZE2921	RING SET, PISTON (0.50)	1	
1	13013ZE2922	RING SET, PISTON (0.75)	1	
1	13013ZE2014	RING SET, PISTON (0.75)	1	
2	13101ZE2W00	PISTON (STD)	1	
2	13102ZE2W00	PISTON (0.25)	1	
2	13103ZE2W00	PISTON (0.50)	1	
2	13104ZE2W00	PISTON (0.75)	1	
3	13111ZE2000	PIN, PISTON	1	
4	13200ZE2000	ROD ASSY., CONNECTING (STD)	1	INCLUDES ITEM W/#
4	13200ZE2305	ROD ASSY., CONNECTING (0.25)	1	INCLUDES ITEM W/#
5#	90001ZE8000	BOLT, CONNECTING ROD	2	
6	90551ZE1000	CLIP, PISTON PIN, 18MM	2	

HONDA GX240K1/U1EDN2 ENGINE — CAMSHAFT ASSY.

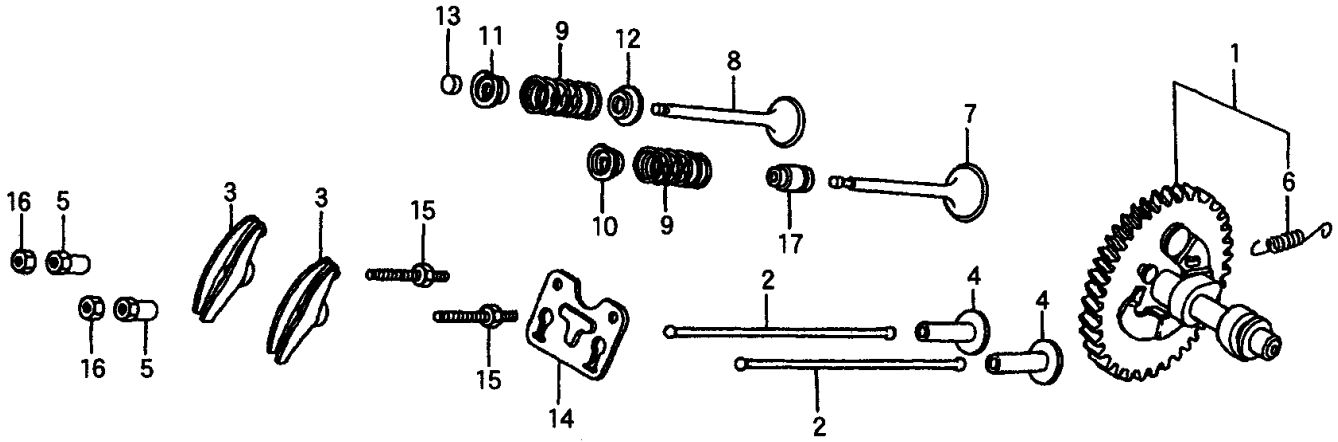

HONDA GX240K1/U1EDN2 ENGINE — CAMSHAFT ASSY.

NO.	PART NO.	PART NAME	QTY.	REMARKS
1	14100ZE2W01	CAMSHAFT ASSY.	1	INCLUDES ITEM W/#
2	14410ZE2013	ROD, PUSH	2	
3	14431ZE2010	ARM, VALVE ROCKER	2	
4	14441ZE2000	LIFTER, VALVE	2	
5	14451ZE1013	PIVOT, ROCKER ARM	2	
6#	14568ZE1000	SPRING, WEIGHT RETURN	1	
7	14711ZE2000	VALVE, IN	1	
8	14721ZE2000	VALVE, EX.	1	
9	14751ZE2003	SPRING, VALVE	2	
10	14771ZE2000	RETAINER, IN. VALVE SPRING	1	
11	14773ZE2000	RETAINER, EX. VALVE SPRING	1	
12◇	14775ZE2010	SEAT, VALVE SPRING	2	
13	14781ZE2000	ROTATOR, VALVE	1	
14	14791ZE2010	PLATE, PUSH ROD GUIDE	1	
15	90012ZE0010	BOLT, PIVOT	2	
16	90206ZE1000	NUT, PIVOT ADJUSTING	2	
17	12209ZE8003	SEAL, VALVE STEM	1	

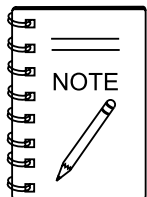

◆GX240K1EDN2: Model GAC3.6HZ, SEPTEMBER 2007 AND BELOW

◇GX160U1EDN2: Model GAC3.6HZ, JANUARY 2008 AND ABOVE

HONDA GX240K1/U1EDN2 ENGINE — RECOIL STARTER ASSY.

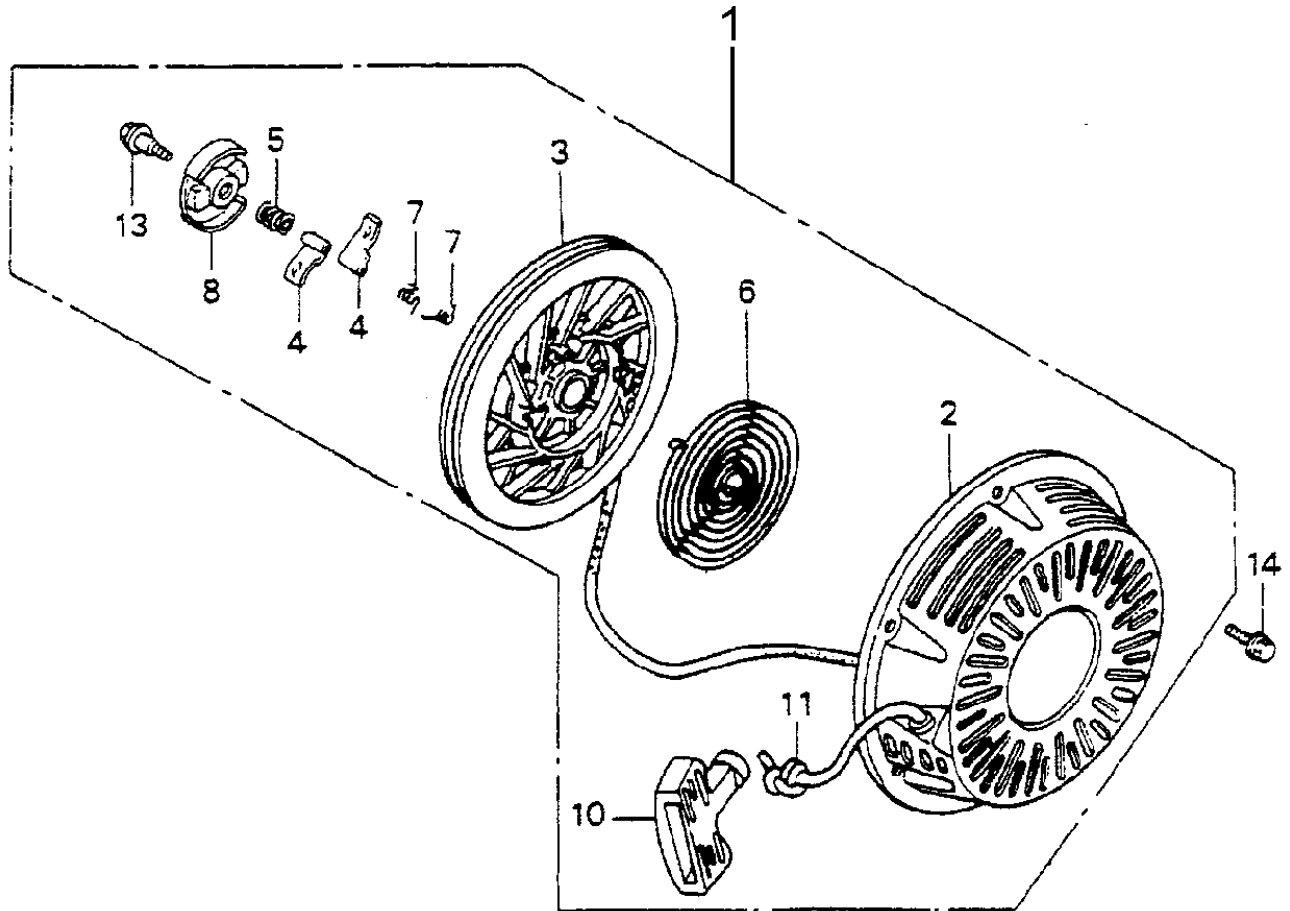

HONDA GX240K1/U1EDN2 ENGINE — RECOIL STARTER ASSY.

<u>NO.</u>	<u>PART NO.</u>	<u>PART NAME</u>	<u>QTY.</u>	<u>REMARKS</u>
1	28400ZE2W01ZB	STARTER ASSY, RECOIL "NH105"	1	INCLUDES ITEMS W/#
2#	28410ZE2W01ZB	CASE COMP., RECOIL STARTER	1	
3#	28421ZE2W01	PULLEY, RECOIL STARTER	1	
4#	28422ZE2W01	RATCHET, STARTER	2	
5#	28441ZE2W01	SPRING, FRICTION	1	
6#	28442ZE2W01	SPRING, STARTER RETURN	1	
7#	28443ZE2W01	SPRING, RATCHET	2	
8#	28444ZE2W01	RETAINER, SPRING	1	
10#	28461ZE2W02	GRIP, STARTER	1	
11#	28462ZE2W11	ROPE, RECOIL STARTER	1	
13#	90004ZE2W01	SCREW, CENTER	1	
14	90008ZE2003	BOLT, FLANGE, 6X10	3	

HONDA GX240K1/U1EDN2 ENGINE — FAN COVER ASSY.

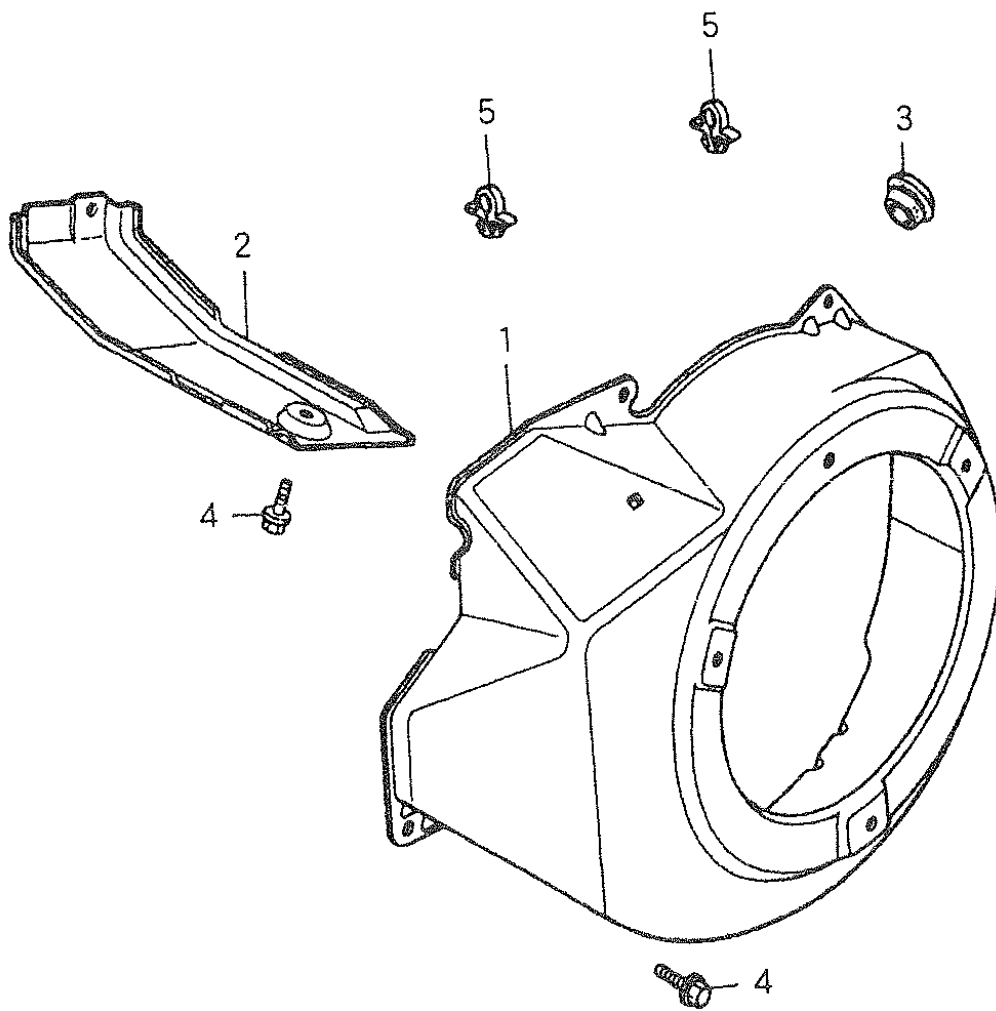

HONDA GX240K1/U1EDN2 ENGINE — FAN COVER ASSY.

<u>NO.</u>	<u>PART NO.</u>	<u>PART NAME</u>	<u>QTY.</u>	<u>REMARKS</u>
1	19610ZE2700ZD	COVER COMP., FAN	1	
2	19631ZE2D00	SHROUD	1	
3	81329567020	GROMMET, DRAIN HOLE	1	
4	90013883000	BOLT, FLANGE, 6X12	6	
5	90654SA4003	CLIP, WIRE HARNESS	2	

HONDA GX240K1/U1EDN2 ENGINE — CARBURETOR ASSY.

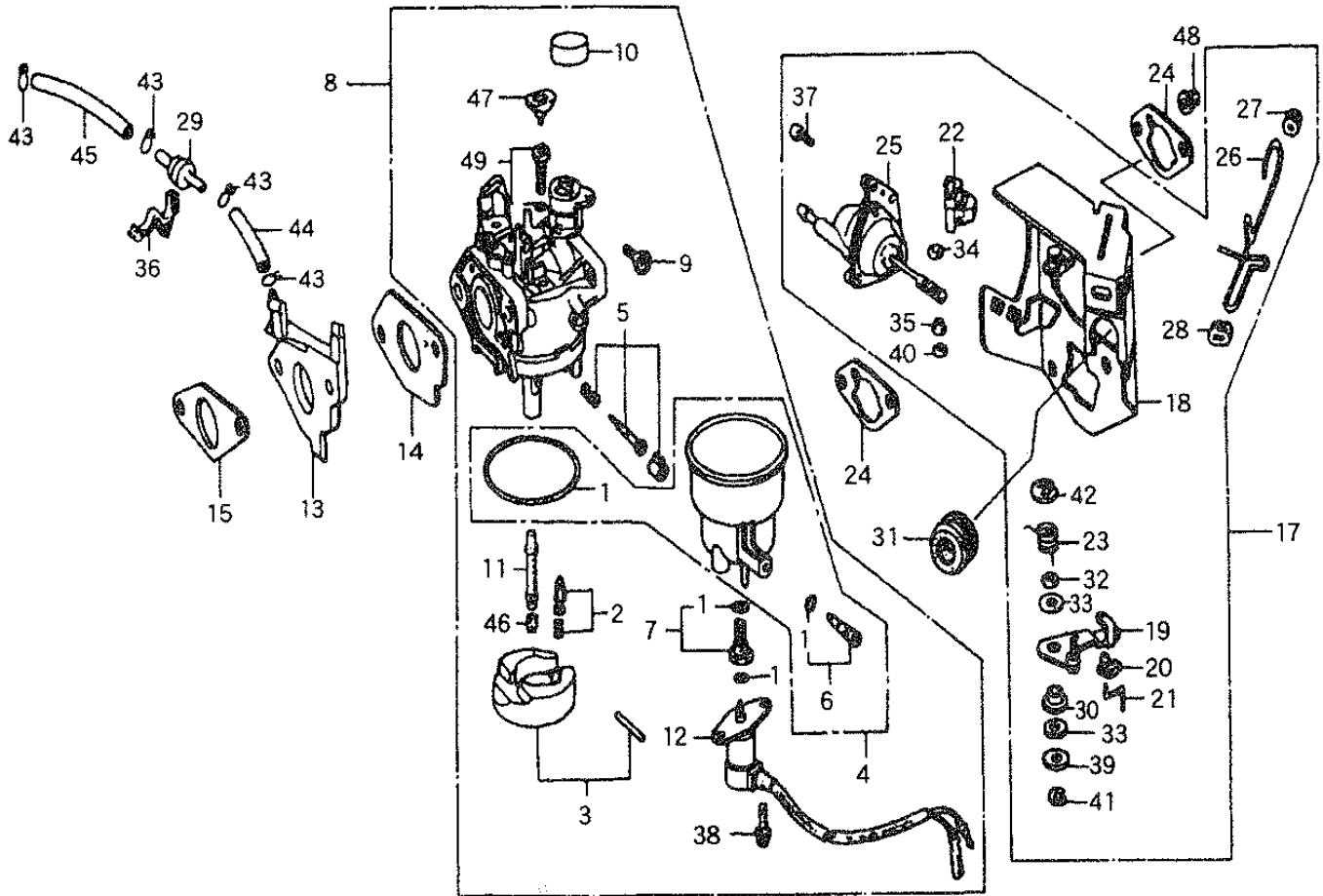

HONDA GX240K1/U1EDN2 ENGINE — CARBURETOR ASSY.

NO.	PART NO.	PART NAME	QTY.	REMARKS
1<	16010ZE3701	GASKET SET	1	
2#	16011ZA0931	VALVE SET, FLOAT	1	
3#	16013ZA0931	FLOAT SET	1	
4#	16015ZA0931	CHAMBER SET, FLOAT	1.....	INCLUDES ITENS W/%
5#	16016ZH7W01	SCREW SET	1	
6%	16024124761	SCREW SET, DRAIN.....	1.....	INCLUDES ITEMS W/<
6%	16024124760	SCREW SET, DRAIN.....	1.....	INCLUDES ITEMS W/<
7#	16028ZA0931	SCREW SET	1	
8◆	16100ZE2F00	CARBURETOR ASSY. (BE72C B).....	1.....	INCLUDES ITEMS W/# UP TO S/N 3337057~3456694
8◆	16100ZE2F01	CARBURETOR ASSY. (BE72C B).....	1.....	INCLUDES ITEMS W/# FROM S/N 4795055
8◇	16100Z5FF01	CARBURETOR ASSY. (BE72L A).....	1.....	INCLUDES ITEMS W/# UP TO S/N 1033893
8◇	16100ZE2F01	CARBURETOR ASSY. (BE72C B).....	1.....	INCLUDES ITEMS W/# FROM S/N 1037325
9#	16124ZE0005	SCREW, THROTTLE STOP	1	
10#	16148141881	CAP, CHOKE DUST	1	
11#	16166ZE2015	NOZZLE, MAIN	1	
12◆#	16230ZE3701	VALVE ASSY., SOLENOID	1	
12◇ #	16230ZE3701	VALVE ASSY., SOLENOID.....	1.....	UP TO S/N 1174424
12◇ #	16230ZE3701	VALVE ASSY., SOLENOID.....	1.....	FROM S/N 1174425
13	16211ZE2700	INSULATOR, CARBURETOR	1	
14	16221ZA0800	PACKING, CARBURETOR	1	
15	16223ZA0800	PACKING, INSULATOR	1	
17◆	16260ZE2722	STAY, MANUAL CHOKE	1.....	INCLUDES ITENS W/\$
17◇	16260ZE2722	STAY, MANUAL CHOKE	1.....	INCLUDES ITENS W/\$ UP TO S/N 1178310
17◇	16260ZE2723	STAY, MANUAL CHOKE	1.....	INCLUDES ITENS W/\$ FROM S/N 1178311
18\$	16261ZE2702	STAY, COMP., SOLENIOD	1	
19\$	16262ZE2711	LEVER, CHOKE	1	
20\$	16263ZA0000	JOINT, ROD	1	
21\$	16264ZE2701	ROD, CHOKE	1	
22\$	16265ZE2721	STOPER, CHOKE ROD	1	
23\$	16268ZE2721	SPRING, MANUAL CHOKE	1	
24	16269ZA0800	PACKING, AIR CLEANER	2	
25◆\$	16400ZE2703	DIAPHRAGM ASSY.	1	
25◇ \$	16400ZE2703	DIAPHRAGM ASSY.....	1.....	UP TO S/N 1174359
25◇ \$	16400ZE2704	DIAPHRAGM ASSY.....	1.....	FROM S/N 1178311

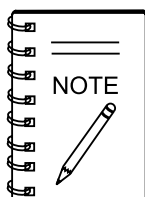

◆GX240K1EDN2: Model GAC3.6HZ, SEPTEMBER 2007 AND BELOW

◇ GX160U1EDN2: Model GAC3.6HZ, JANUARY 2008 AND ABOVE

HONDA GX240K1/U1EDN2 ENGINE — CARBURETOR ASSY.

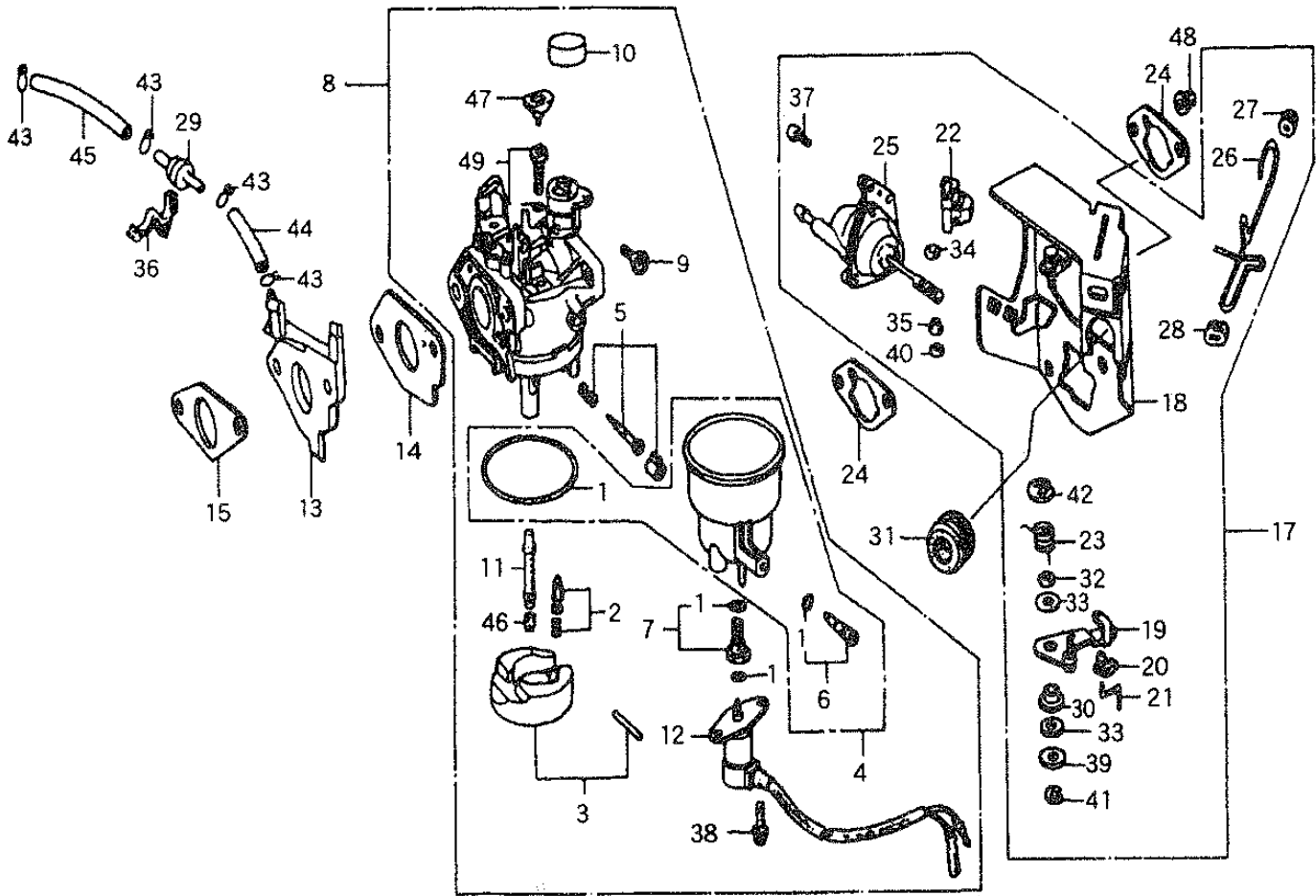

HONDA GX240K1/U1EDN2 ENGINE — CARBURETOR ASSY.

<u>NO.</u>	<u>PART NO.</u>	<u>PART NAME</u>	<u>QTY.</u>	<u>REMARKS</u>
26\$	16611ZE2711	ROD, CHOKE CONTROL	1	
27\$	16613893000	GROMMET, CHOKE ROD	1	
28\$	16615893000	GUIDE, CHOKE ROD	1	
29	36135ZV003	VALVE, DASHPOT CHECK	1	
30\$	53149964003	BUSH, ARM PIVOT	1	
31	88911MJ3000	GROMMET, FENDER	1	
32\$	90431ZE2700	WASHER, CHOKE LEVER	1	
33\$	90432ZE2700	SEAL, CHOKE LEVER	2	
34\$	90433ZE2700	WASHER, THRUST	1	
35\$	90434ZE2700	COLLAR, LEVER	1	
36	90650SD9003	CLIP, WIRE HARNESS	1	
37\$	93500050120A	SCREW, PAN, 5X12	2	
38#	938920501218	SCREW, WASHER 5X12	2	
39	9410305000	WASHER, FLAT 5MM	1	
40\$	9454002010	E-RING 2MM	1	
41\$	9454004010	E-RING 4MM	1	
42\$	9454007010	E-RING 7MM	1	
43	9500202070	CLIP B7, TUBE	4	
44	950053506510	TUBE, 3.5X65	1	
45	950053513010	TUBE, 3.5X130	1	
46	99101ZF50750	JET, MAIN, #78	1	
46	99101ZF50780	JET, MAIN, #80	1	
46◆#	99101ZF50800	JET, MAIN, #82	1	
47#	16172ZE3W10	COLLAR SET	1	
48	9405006000	NUT, FLANGE 6MM	1	
49#	99204ZA00450	JET SET, PILOT, #45	1	

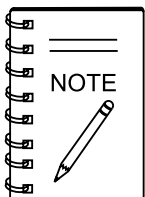

◆GX240K1EDN2: Model GAC3.6HZ, SEPTEMBER 2007 AND BELOW

◇GX160U1EDN2: Model GAC3.6HZ, JANUARY 2008 AND ABOVE

HONDA GX240K1/U1EDN2 ENGINE — AIR CLEANER ASSY.

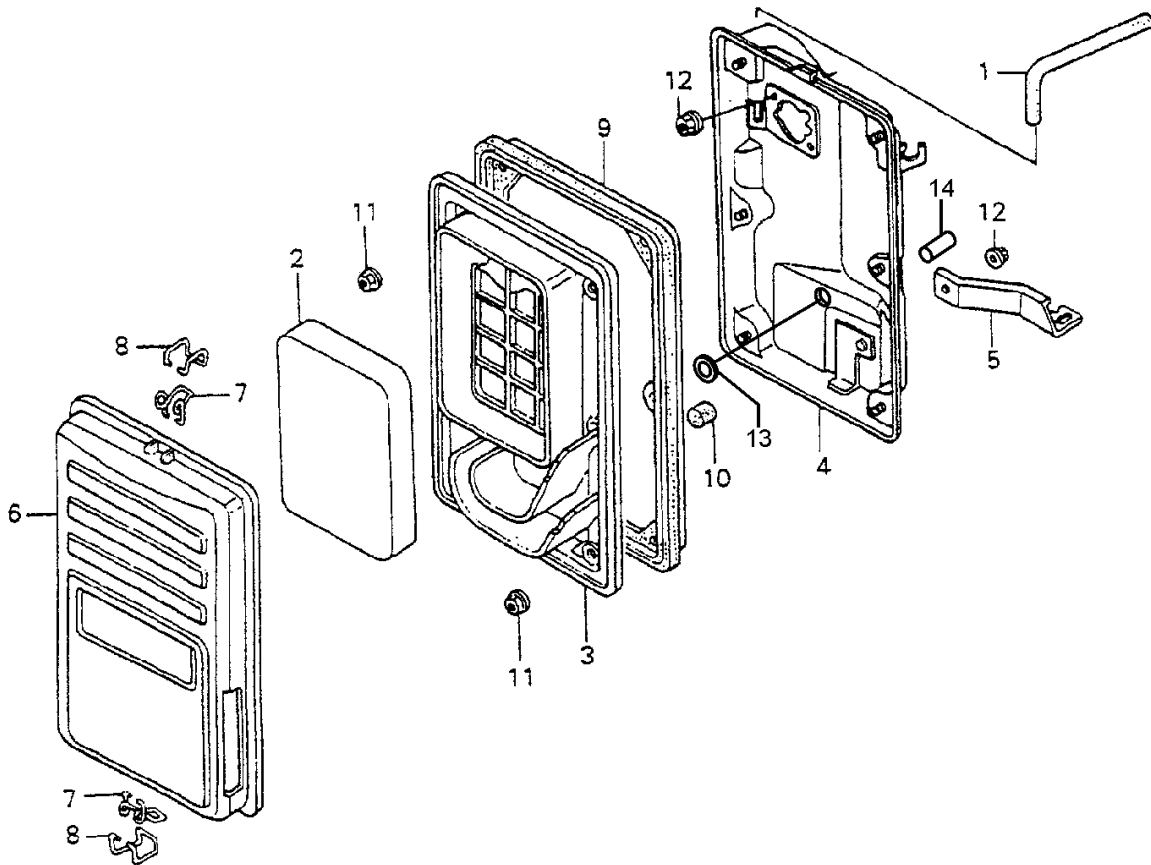

HONDA GX240K1/U1EDN2 ENGINE — AIR CLEANER ASSY.

<u>NO.</u>	<u>PART NO.</u>	<u>PART NAME</u>	<u>QTY.</u>	<u>REMARKS</u>
1	15721ZB4000	TUBE BREATHER	1	
2	17211899000	ELEMENT, AIR CLEANER	1	
3◆	17212ZB4003	SEPARATOR, AIR CLEANER	1	
3◇	17212ZB4003	SEPARATOR, AIR CLEANER.....	1.....	USE UP TO S/N 119603
3◇	17212Z5R000	SEPARATOR, AIR CLEANER.....	1.....	USE FROM S/N 119604
4	17220ZB4003	CASE COMP., AIR CLEANER	1	
5	17222ZB4000	STAY, AIR CLEANER	1	
6	17231899000	COVER COMP., AIR CLEANER	1	
7	17235899000	CLIP A, AIR CLEANER WIRE	2	
8	17236899000	CLIP B, AIR CLEANER WIRE	2	
9	17252899000	SEAL, AIR CLEANER	1	
10	17367413690	FILTER, DRAIN TUBE	1	
11	9405005000	NUT, FLANGE, 5 MM	6	
12	9405006000	NUT, FLANGE, 6 MM	3	
13◇	17232898000	GROMMET, AIR CLEANER	1	
14◇	90634ZL8H00	CAP, SEALING	1	

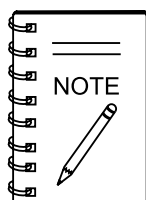

◆GX240K1EDN2: Model GAC3.6HZ, SEPTEMBER 2007 AND BELOW

◇GX160U1EDN2: Model GAC3.6HZ, JANUARY 2008 AND ABOVE

HONDA GX240K1/U1EDN2 ENGINE — FLYWHEEL ASSY.

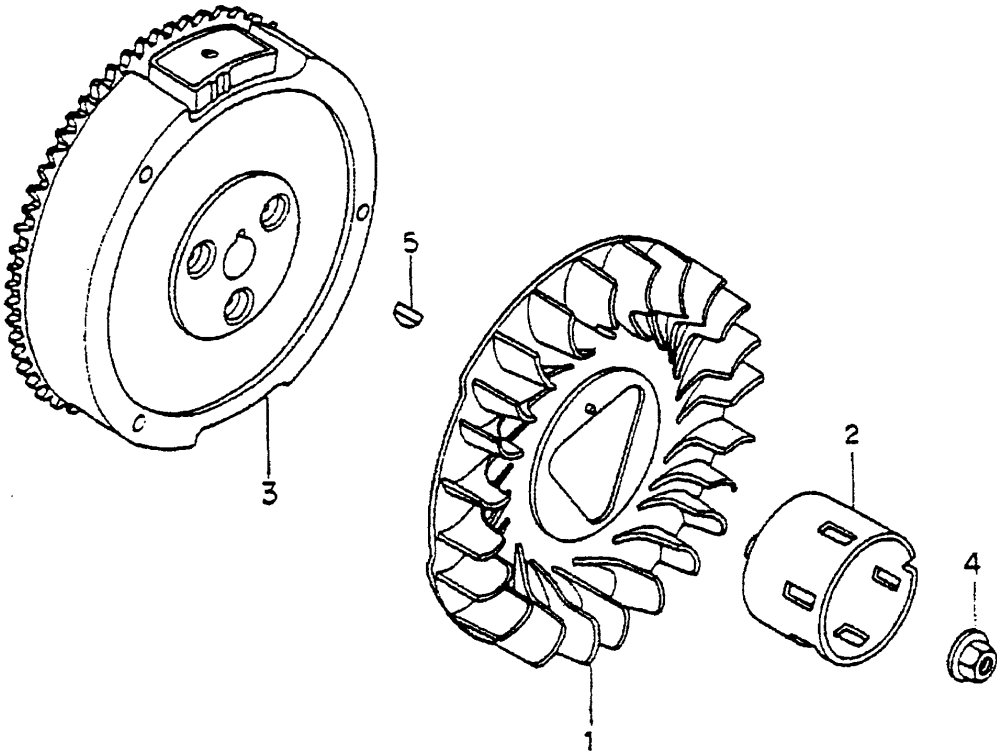

HONDA GX240K1/U1EDN2 ENGINE — FLYWHEEL ASSY.

NO.	PART NO.	PART NAME	QTY.	REMARKS
1	19511ZE2000	FAN, COOLING	1	
2	28451ZE2W01	PULLEY, STARTER	1	
3	31100ZE2812	FLYWHEEL COMP.	1	
4◆	90201ZE3790	NUT, SPECIAL, 16MM.....	1	USE UP TO S/N 3467138
4◆	90201ZE3V00	NUT, SPECIAL, 16MM.....	1	USE FROM S/N 3467139
4◇	90201ZE3V00	NUT, SPECIAL, 16MM	1	
5	90741ZE2000	KEY, SPECIAL WOODRUFF	1	



- ◆GX240K1EDN2: Model GAC3.6HZ, SEPTEMBER 2007 AND BELOW
- ◇ GX160U1EDN2: Model GAC3.6HZ, JANUARY 2008 AND ABOVE

HONDA GX240K1/U1EDN2 ENGINE — IGNITION COIL ASSY.

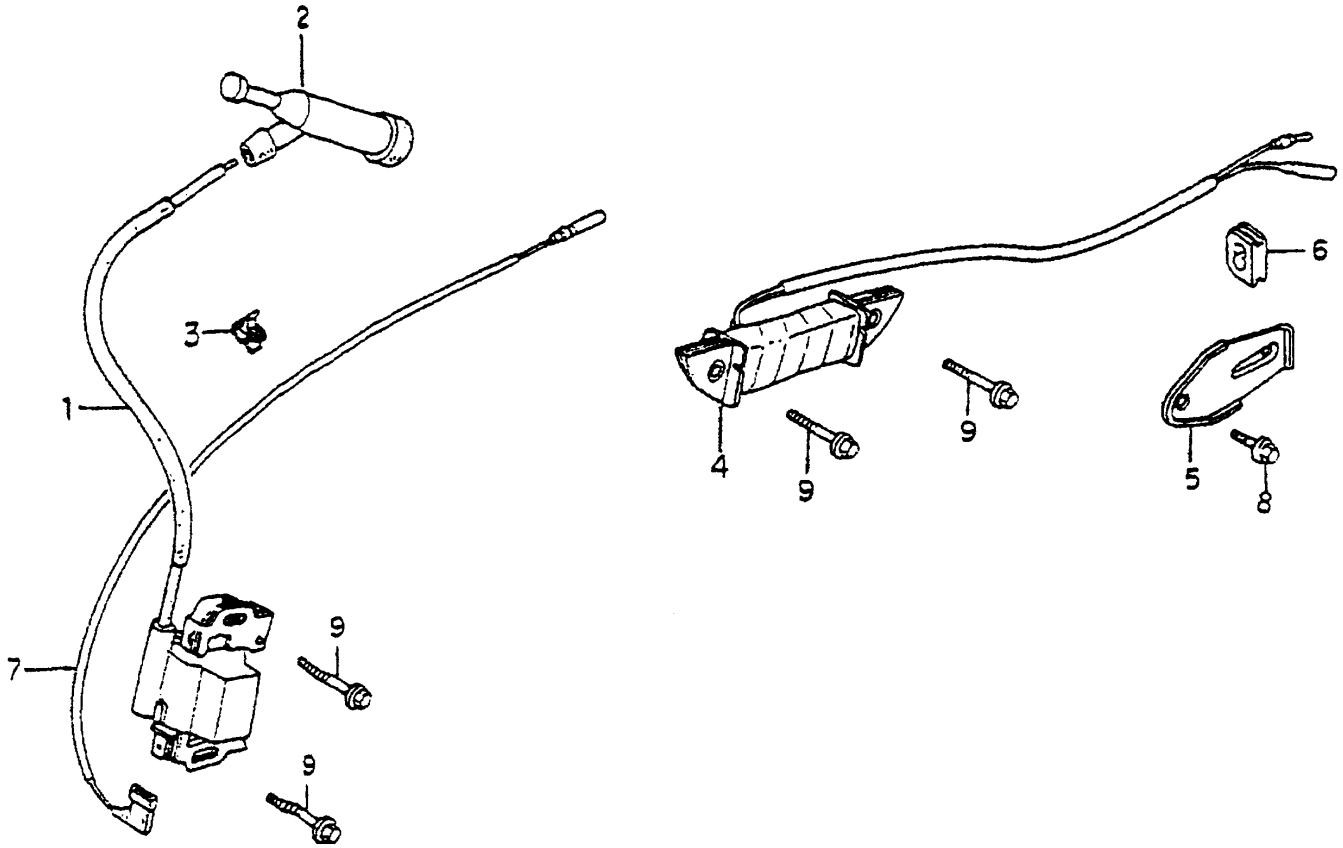

HONDA GX240K1/U1EDN2 ENGINE — IGNITION COIL ASSY.

<u>NO.</u>	<u>PART NO.</u>	<u>PART NAME</u>	<u>QTY.</u>	<u>REMARKS</u>
1◆	30500ZE2023	COIL ASSY., IGNITION	1	
1◇	30500ZF6W02	COIL ASSY., IGNITION.....	1.....	USE UP TO S/N 1167470
1◇	30500ZF6W03	COIL ASSY., IGNITION.....	1.....	USE FROM S/N 1167471
2	30700ZE7013	CAP ASSY., NOISE SUPPRESSON	1	
3	36103ZE1000	HOLDER, STOP SWITCH CORD	1	
4	31510ZE3003	COIL ASSY., LAMP 12V/25W	1	
5	31511ZE2000	CLAMPER, CORD	1	
6	31512ZE2000	GROMMET, CORD	1	
7	36101ZE2701	CORD, STOP SWITCH	1	
8	90013883000	BOLT, FLANGE, 6X12	1	
9	90015883000	BOLT, FLANGE, 6X28	6	

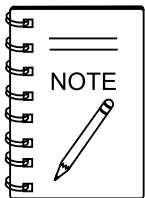

◆GX240K1EDN2: Model GAC3.6HZ, SEPTEMBER 2007 AND BELOW

◇GX160U1EDN2: Model GAC3.6HZ, JANUARY 2008 AND ABOVE

HONDA GX240K1/U1EDN2 ENGINE — GOV. CONTROL ASSY.

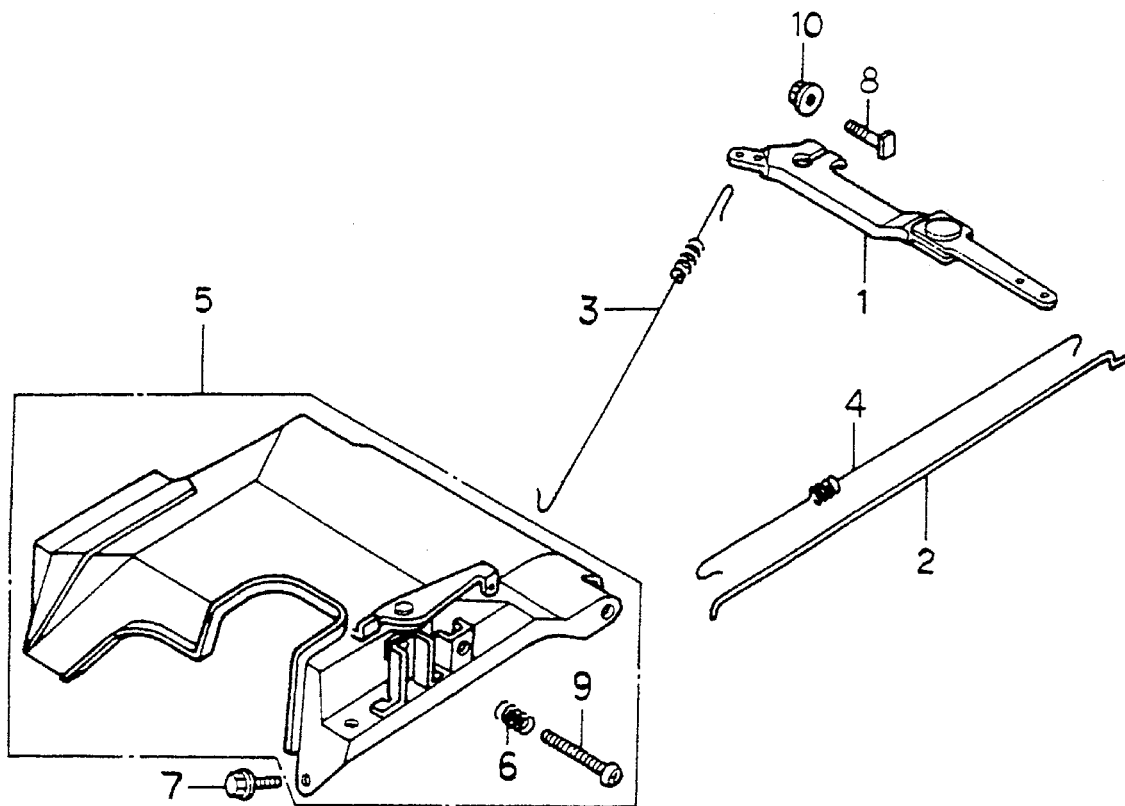

HONDA GX240K1/U1EDN2 ENGINE — GOV. CONTROL ASSY.

<u>NO.</u>	<u>PART NO.</u>	<u>PART NAME</u>	<u>QTY.</u>	<u>REMARKS</u>
1	16550ZE2700	ARM, GOVERNOR	1	
2	16555ZE2000	ROD, GOVERNOR	1	
3	16561ZE2000	SPRING, GOVERNOR	1	
4	16562ZE2700	SPRING, THROTTLE RETURN	1	
5	16570ZE2701	CONTROL ASSY.....	1	INCLUDES ITEMS W.#
6#	16584883300	SPRING, CONTROL ADJUSTING	1	
7	90013883000	BOLT, FLANGE, 6X12	2	
8	90015ZE5010	BOLT, GOVERNOR ARM	1	
9#	93600050350A	SCREW, PAN, 5X35	1	
10	9405006000	NUT, FLANGE, 6MM	1	

HONDA GX240K1/U1EDN2 ENGINE — AUTO THROTTLE ASSY.

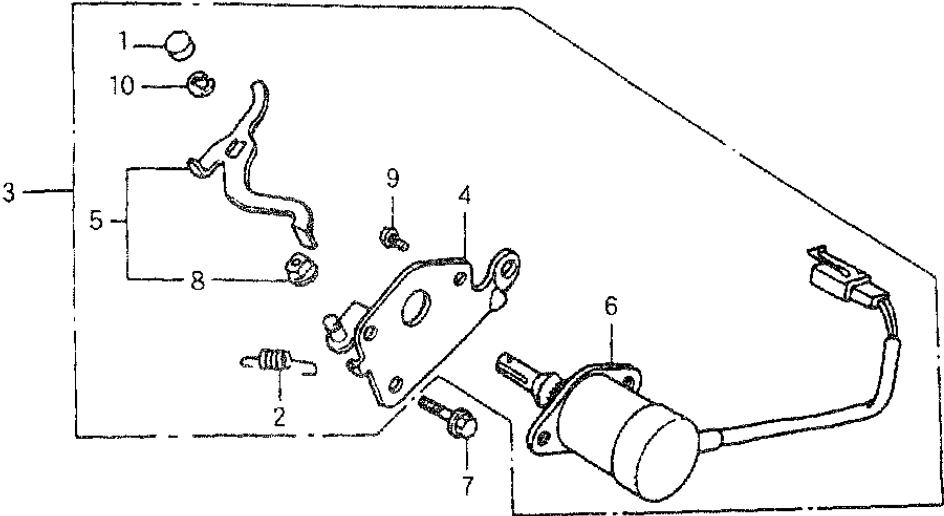

HONDA GX240K1/U1EDN2 ENGINE — AUTO THROTTLE ASSY.

<u>NO.</u>	<u>PART NO.</u>	<u>PART NAME</u>	<u>QTY.</u>	<u>REMARKS</u>
1#	16252ZA1000	CAP, CHOKE LEVER	1	
2#	16268893000	SPRING, CHOKE RETURN	1	
3◆	16270ZB4000	AUTO THROTTLE ASSY.....	1	INCLUDES ITEMS W/#
3◇	16270ZB4010	AUTO THROTTLE ASSY.....	1	INCLUDES ITEMS W/#
4#	16271ZB4000	STAY, SOLENOID THROTTLE	1	
5#	16273ZB4000	LEVER COMP., SOLENOID THROTTLE	1	INCLUDES ITEMS W/%
6◆#	36160ZB4003	SOLENOID ASSY.	1	
6◇#	36160ZB4013	SOLENOID ASSY.	1	
7	90013883000	BOLT, FLANGE 6X12	1	
8%	91502ZB4701	BUSH, AUTO THROTTLE LEVER	1	
9#	93500050080A	SCREW. PAN 5X8	2	
10#	9454004018	E-RING 4MM	1	

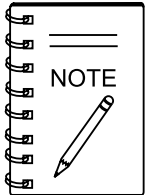

- ◆GX240K1EDN2: Model GAC3.6HZ, SEPTEMBER 2007 AND BELOW
- ◇GX160U1EDN2: Model GAC3.6HZ, JANUARY 2008 AND ABOVE

HONDA GX240K1/U1EDN2 ENGINE — FUEL COCK ASSY.

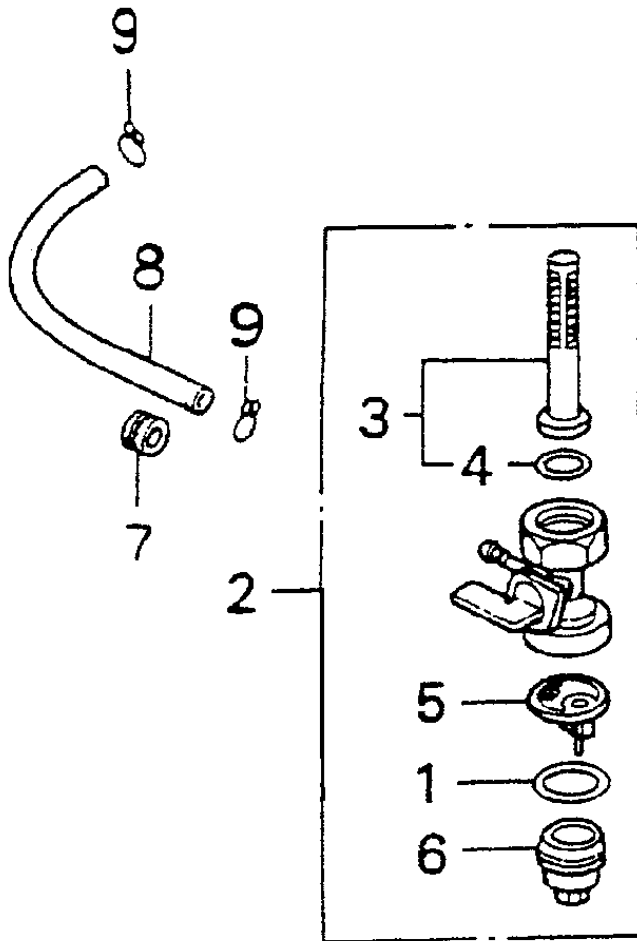

HONDA GX240K1/U1EDN2 ENGINE — FUEL COCK ASSY.

<u>NO.</u>	<u>PART NO.</u>	<u>PART NAME</u>	<u>QTY.</u>	<u>REMARKS</u>
1#	16173001004	PACKING, FUEL STRAINER CUP	1	
2	16950ZB4015	COCK ASSY., FUEL	1.....	INCLUDES ITEMS W/#
3#	16952ZB4005	SCREEN, FUEL STRAINER.....	1.....	INCLUDES ITEMS W/%
4#%	16958397771	O-RING	1	
5#	16959471831	FILTER CUP	1	
6#	16967GA6671	CUP, FUEL STRAINER	1	
7	90854ZB2000	RUBBER, FUEL (9X15X10)	1	
8	950014519040	TUBE, FUEL, 4.5X190	1	
9◆	9500202080	CLIP B8, TUBE	2	
9◇	9500202080	CLIP B8, TUBE	2.....	USE UP TO S/N 1037325
9◇	950024080008	CLAMP D8, TUBE.....	2.....	USE FROM S/N 1037326

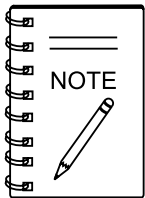

◆GX240K1EDN2: Model GAC3.6HZ, SEPTEMBER 2007 AND BELOW

◇GX160U1EDN2: Model GAC3.6HZ, JANUARY 2008 AND ABOVE

HONDA GX240K1/U1EDN2 ENGINE — DECAL ASSY.

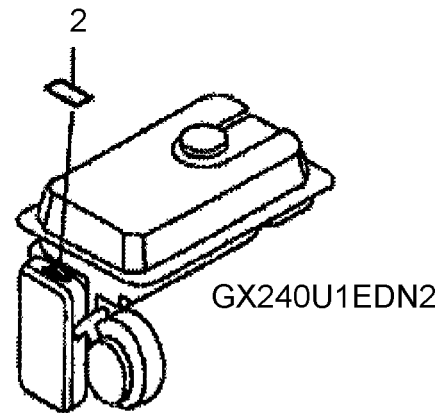
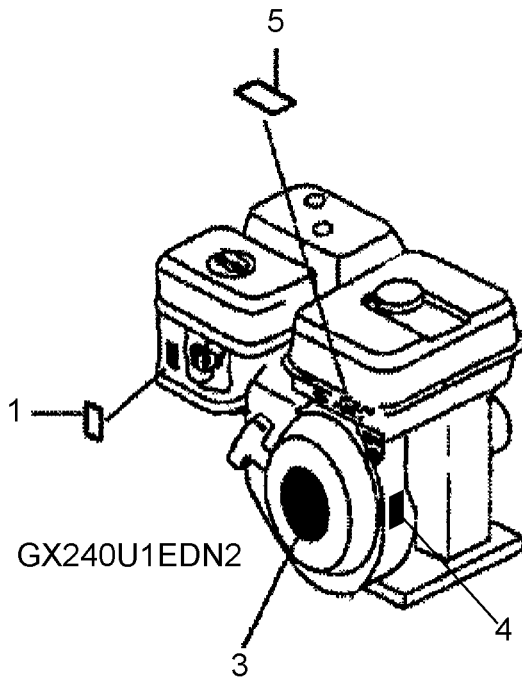
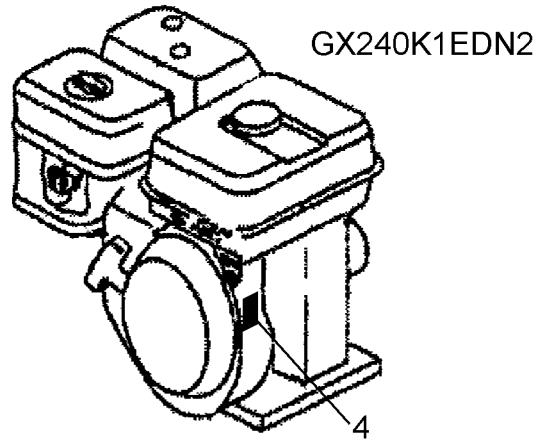
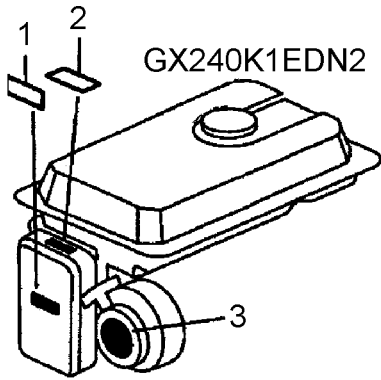

HONDA GX240K1/U1EDN2 ENGINE — DECAL ASSY.

<u>NO.</u>	<u>PART NO.</u>	<u>PART NAME</u>	<u>QTY.</u>	<u>REMARKS</u>
1	87533ZC0630	DECAL, AIR CLEANER	1	
2◆	87528898620	DECAL, CHOKE	1	
2◇	87528ZH7000	DECAL, CHOKE (GRAY)	1.....	USE UP TO S/N 1028751
2◇	87528898620	DECAL, CHOKE	1.....	USE FROM S/N 1028752
3◆	87521ZE2W01	EMBLEM (GX240 HONDA 8.0.....	1.....	USE UP TO S/N 3117235
3◆	87521ZE2W02	EMBLEM (GX240 HONDA 8.0.....	1.....	USE FROM S/N 4465232
3◇	87521ZE2W03	EMBLEM (GX240 HONDA 8.0)	1.....	USE UP TO S/N 1167470
3◇	87521ZE2W04	EMBLEM (GX240)	1.....	USE FROM S/N 1167471
4	87594ZB4A00	MARK, OIL CAUTION	1	
5◇	87516ZH7000	MARK OPERATOR CAUTION (ENGLISH).....	1.....	USE UP TO S/N 1237019
5◇	87516ZH7010	MARK OPERATOR CAUTION (ENGLISH).....	1.....	USE FROM S/N 1237020
5◇	87516ZH7800	MARK OPERATOR CAUTION (FRENCH).....	1.....	USE UP TO S/N 1237019
5◇	87519ZH7801	MARK OPERATOR CAUTION (FRENCH).....	1.....	USE FROM S/N 1237020

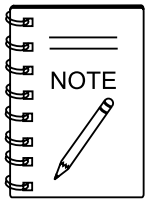

- ◆GX240K1EDN2: Model GAC3.6HZ, SEPTEMBER 2007 AND BELOW
- ◇ GX160U1EDN2: Model GAC3.6HZ, JANUARY 2008 AND ABOVE

HONDA GX240K1/U1EDN2 ENGINE — TOOL KIT

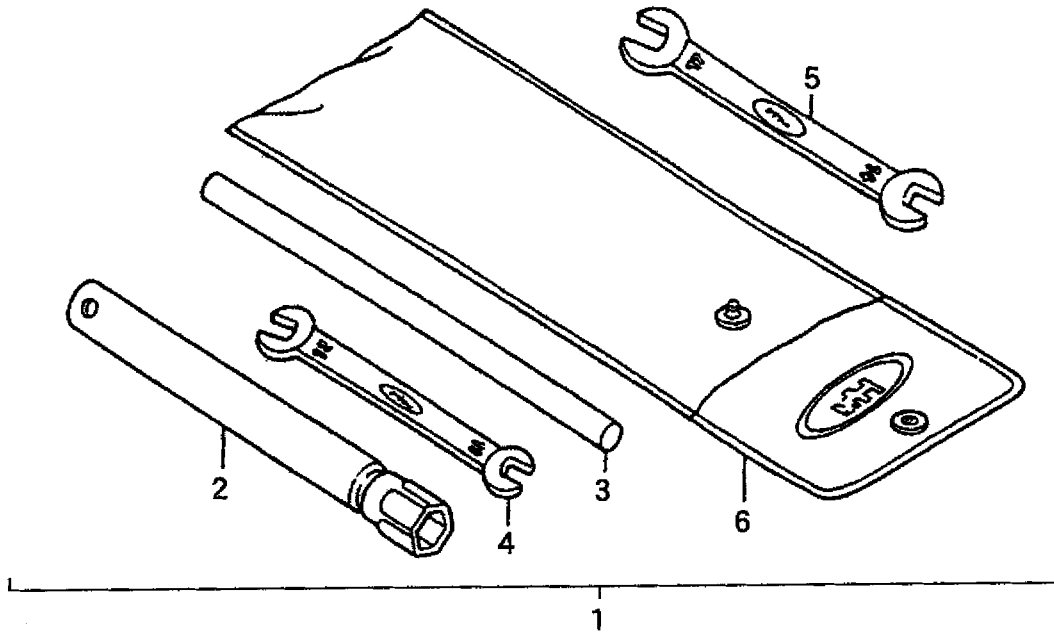

HONDA GX240K1/U1EDN2 ENGINE — TOOL KIT

<u>NO.</u>	<u>PART NO.</u>	<u>PART NAME</u>	<u>QTY.</u>	<u>REMARKS</u>
1	89000ZE1000	TOOL KIT.....	1.....	INCLUDES ITEMS W/#
2#	89218ZE1000	WRENCH COMP. (SPARK PLUG)	1	
3#	89219805000	HANDLE, BOX WRENCH	1	
4#	9900110120	SAPNNER, 10X12	1	
5#	9900114170	SAPNNER, 14X17	1	
6#	9900802300	BAG TOOL	1	

TERMS AND CONDITIONS OF SALE — PARTS

PAYMENT TERMS

Terms of payment for parts are net 30 days.

FREIGHT POLICY

All parts orders will be shipped collect or prepaid with the charges added to the invoice. All shipments are F.O.B. point of origin. Multiquip's responsibility ceases when a signed manifest has been obtained from the carrier, and any claim for shortage or damage must be settled between the consignee and the carrier.

MINIMUM ORDER

The minimum charge for orders from Multiquip is \$15.00 net. Customers will be asked for instructions regarding handling of orders not meeting this requirement.

RETURNED GOODS POLICY

Return shipments will be accepted and credit will be allowed, subject to the following provisions:

1. A Returned Material Authorization must be approved by Multiquip prior to shipment.
2. To obtain a Return Material Authorization, a list must be provided to Multiquip Parts Sales that defines item numbers, quantities, and descriptions of the items to be returned.
 - a. The parts numbers and descriptions must match the current parts price list.
 - b. The list must be typed or computer generated.
 - c. The list must state the reason(s) for the return.
 - d. The list must reference the sales order(s) or invoice(s) under which the items were originally purchased.
 - e. The list must include the name and phone number of the person requesting the RMA.
3. A copy of the Return Material Authorization must accompany the return shipment.
4. Freight is at the sender's expense. All parts must be returned freight prepaid to Multiquip's designated receiving point.

5. Parts must be in new and resalable condition, in the original Multiquip package (if any), and with Multiquip part numbers clearly marked.
6. The following items are not returnable:
 - a. Obsolete parts. (If an item is in the price book and shows as being replaced by another item, it is obsolete.)
 - b. Any parts with a limited shelf life (such as gaskets, seals, "O" rings, and other rubber parts) that were purchased more than six months prior to the return date.
 - c. Any line item with an extended dealer net price of less than \$5.00.
 - d. Special order items.
 - e. Electrical components.
 - f. Paint, chemicals, and lubricants.
 - g. Decals and paper products.
 - h. Items purchased in kits.
7. The sender will be notified of any material received that is not acceptable.
8. Such material will be held for five working days from notification, pending instructions. If a reply is not received within five days, the material will be returned to the sender at his expense.
9. Credit on returned parts will be issued at dealer net price at time of the original purchase, less a 15% restocking charge.
10. In cases where an item is accepted, for which the original purchase document can not be determined, the price will be based on the list price that was effective twelve months prior to the RMA date.
11. Credit issued will be applied to future purchases only.

PRICING AND REBATES

Prices are subject to change without prior notice. Price changes are effective on a specific date and all orders received on or after that date will be billed at the revised price. Rebates for price declines and added charges for price increases will not be made for stock on hand at the time of any price change.

Multiquip reserves the right to quote and sell direct to Government agencies, and to Original Equipment Manufacturer accounts who use our products as integral parts of their own products.

SPECIAL EXPEDITING SERVICE

A \$35.00 surcharge will be added to the invoice for special handling including bus shipments, insured parcel post or in cases where Multiquip must personally deliver the parts to the carrier.

LIMITATIONS OF SELLER'S LIABILITY

Multiquip shall not be liable hereunder for damages in excess of the purchase price of the item with respect to which damages are claimed, and in no event shall Multiquip be liable for loss of profit or good will or for any other special, consequential or incidental damages.

LIMITATION OF WARRANTIES

No warranties, express or implied, are made in connection with the sale of parts or trade accessories nor as to any engine not manufactured by Multiquip. Such warranties made in connection with the sale of new, complete units are made exclusively by a statement of warranty packaged with such units, and Multiquip neither assumes nor authorizes any person to assume for it any other obligation or liability whatever in connection with the sale of its products. Apart from such written statement of warranty, there are no warranties, express, implied or statutory, which extend beyond the description of the products on the face hereof.

Effective: February 22, 2006

OPERATION AND PARTS MANUAL

HERE'S HOW TO GET HELP

PLEASE HAVE THE MODEL AND SERIAL
NUMBER ON-HAND WHEN CALLING

UNITED STATES

Multiquip Corporate Office

18910 Wilmington Ave.
Carson, CA 90746
Contact: mq@multiquip.com

Tel. (800) 421-1244
Fax (800) 537-3927

Mayco Parts

800-306-2926
310-537-3700

Fax: 800-672-7877
Fax: 310-637-3284

Service Department

800-421-1244
310-537-3700

Fax: 310-537-4259

MQ Parts Department

800-427-1244
310-537-3700

Fax: 800-672-7877
Fax: 310-637-3284

Warranty Department

800-421-1244, Ext. 279
310-537-3700, Ext. 279

Fax: 310-537-1173

Technical Assistance

800-478-1244

Fax: 310-631-5032

MEXICO

MQ Cipsa

Carr. Fed. Mexico-Puebla KM 126.5
Momoxpan, Cholula, Puebla 72760 Mexico
Contact: pmastretta@cipsa.com.mx

Tel: (52) 222-225-9900
Fax: (52) 222-285-0420

UNITED KINGDOM

Multiquip (UK) Limited Head Office

Unit 2, Northpoint Industrial Estate,
Global Lane,
Dukinfield, Cheshire SK16 4UJ
Contact: sales@multiquip.co.uk

Tel: 0161 339 2223
Fax: 0161 339 3226

CANADA

Multiquip

4110 Industriel Boul.
Laval, Quebec, Canada H7L 6V3
Contact: jmartin@multiquip.com

Tel: (450) 625-2244
Tel: (877) 963-4411
Fax: (450) 625-8664

© COPYRIGHT 2010, MULTIQUIP INC.

Multiquip Inc and the MQ logo are registered trademarks of Multiquip Inc. and may not be used, reproduced, or altered without written permission. All other trademarks are the property of their respective owners and used with permission.

This manual MUST accompany the equipment at all times. This manual is considered a permanent part of the equipment and should remain with the unit if resold.

The information and specifications included in this publication were in effect at the time of approval for printing. Illustrations, descriptions, references and technical data contained in this manual are for guidance only and may not be considered as binding. Multiquip Inc. reserves the right to discontinue or change specifications, design or the information published in this publication at any time without notice and without incurring any obligations.

Your Local Dealer is:

