



UWKA Wheel Kit

For Use On Portable: Generators,
Pumps, and Welders

Installation Instructions

The following instructions are intended to assist the user in the assembly of the UWKA Wheel Kit for use on Multiquip portable generators, pumps, and welders. Please read the entire assembly instructions before assembling the wheel kit.

TOOLS:

- Ratchet Set with 7/16, 1/2 inch socket
- Adjustable Wrench or 7/16, 1/2 inch open end wrench

PARTS:

NO.	P/N	PART NAME	QTY.
1	29983	Wheel/Tire	2
2	8158	Pin, Cotter 3/16d x 1-1/2	2
3	29981	Axle Mount W/A, Left (2 7/8")	1
4	29982	Axle Mount W/A, Right (2 7/8")	1
5	26250	Screw, HHC 1/4-20 x 1 3/4	4
6	0948	Washer, Flat SAE 1/4	16
7	10024	Nut, Nyloc 1/4-20	12
8	29750	U-bolt, 1/4-20 x 1.0 x 2.75	4
9	29757	Clamp Clip	4
10	29787	Pin Clevis 5/16 x 1-1/2	2
11	0300 B	Washer, Flat SAE 5/16	4
12	0683	Pin, cotter 3/32D x 3/4	2
13	29739	Tube, Handle	2
14	19717	Grip, Hand	2
15	29746	Handle Mount W/A	2
16	4001	Washer, Flat USS 3/8 Pld	2
17	19716	Crutch Tip	2

PROCEDURE:

1. Assemble the Axle Mounts (Figure 1) -

Push the **wheel** (item 1) on the **axle mount** (Item 3) and then insert the **cotter pin** (item 2) through the outer axle hole. Bend the cotter pin to secure the wheel in place. Repeat this step for the other axle mount (item 4).

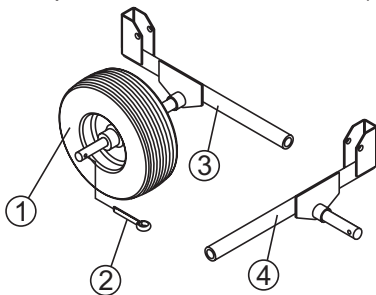
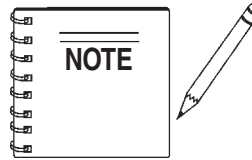

Figure 1. Axle Mount Assembly

NOTE: Axle Mount Length is 2 7/8 inches.

2. Turning your unit on its side, or while having a second person lifting the side in the air, place the axle mount under the frame tubing on the side of the unit as shown in Figure 2.



Attach the axle mounts so that the wheels are located under the heaviest end of your unit. The placement of the axle mounts may differ on each type of equipment.

Set the rounded corner of the tubing in the bracket at the back of the axle mount and place a **screw** (item 5) and **flat washer** (item 6) through the holes, securing the tubing in place. Place another flat washer and a **nylock nut** (item 7) on the threaded end of the screw and tighten.

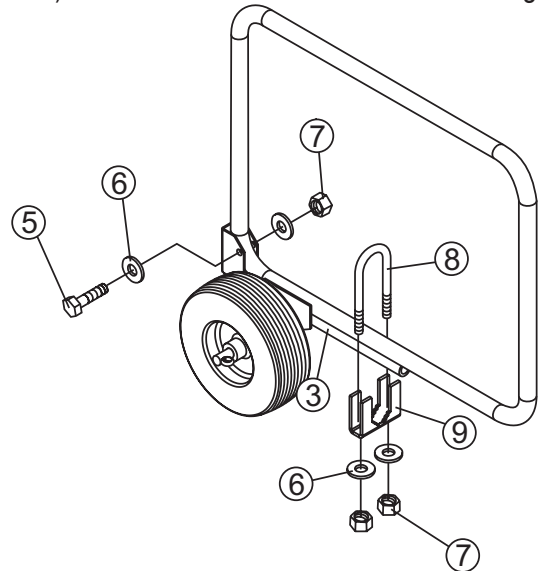

Figure 2. Securing the Axle Mount to the Frame

3. Secure the axle mount to the frame tubing by placing a **u-bolt** (item 8) over the frame tubing and the axle mount and insert a **clamp clip** (item 9) onto the u-bolt. Place **flat washers** (item 6) and **nyloc nuts** (item 7) on the threaded ends of the u-bolt and tighten until the clamp securely holds the axle mount to the frame tubing.

Repeat steps 2-3 to attach the axle mount to the opposite side of the unit.



UWKA Wheel Kit

For Use On Portable: Generators,
Pumps, and Welders

4. Insert a **flat washer** (item 16) into the **crutch tip** (item 17) and place the combined items over the open end of the **handle mount** (item 15).

Insert the end of the **handle tube** (item 13) with the screw hole into the top bracket of the handle mount. Slide **clevis pin** (item 10) and **flat washer** (item 11) through the bracket and handle tube holes. Place another flat washer (item 11) onto end of clevis pin (item 10) and insert cotter pin (item 12) through hole on clevis pin. Bend leads on cotter pin to hold handle tube in place.

Slide the **hand grip** (item 14) over the open end of the handle tube.

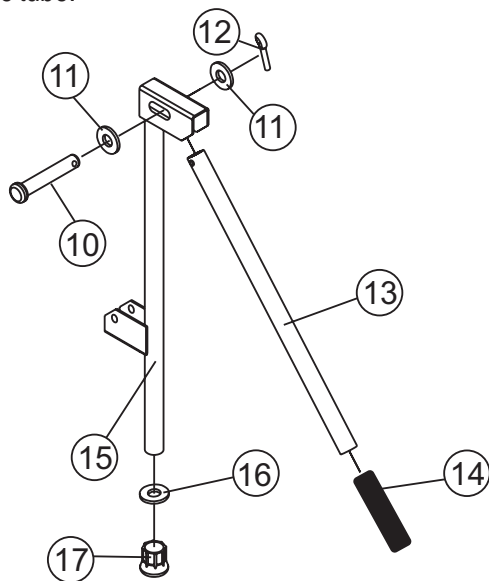

Figure 3. Handle Mount Assembly

5. Lifting the front of the unit, set the rounded corner of the frame tubing in the bracket on the handle mount (Figure 4). Place a **screw** (item 5) and **flat washer** (item 6) through the holes, securing the tubing in place. place another flat washer and a **nyloc nut** (item 7) on the threaded end of the screw and tighten.

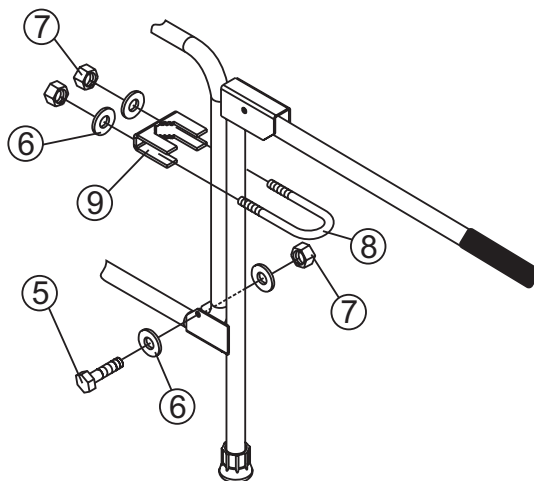

Figure 4. Securing the Handle Mount to the Frame.

6. Secure the handle mount to the frame tubing by placing a **u-bolt** (item 8) around the frame tubing and the handle mount and insert a **clamp clip** (item 9) onto the u-bolt. Place **flat washers** (item 6) and **nyloc nuts** (item 7) on the threaded ends of the u-bolt and tighten until the clamp securely holds the handle mount to the frame tubing.

Repeat steps 4 thru 6 to attach the handle mount to the other side of the unit.

Here's how to get help...

MULTIQIP INC. CORPORATE OFFICE

18910 Wilmington Ave. 800-421-1244
 Carson, CA 90746 FAX: 310-537-3927
 Email: mq@multiquip.com
 Internet: www.multiquip.com

PARTS DEPARTMENT

800-427-1244 FAX: 800-672-7877
 310-537-3700 FAX: 310-637-3284

SERVICE DEPARTMENT

800-478-1244 FAX: 310-537-4259
 310-537-3700

TECHNICAL ASSISTANCE

800-478-1244 FAX: 310-631-5032

WARRANTY DEPARTMENT

800-421-1244, EXT. 279 FAX: 310-537-1173
 310-537-3700, EXT. 279



MULTIQIP INC.

18910 WILMINGTON AVE.
 CARSON, CALIFORNIA 90746
 800-421-1244 • 310-537-3700
 FAX: 310-537-3927
 E-mail: mq@multiquip.com
 Internet: multiquip.com

Atlanta • Boise • Newark
 Montreal, Canada • Manchester, UK
 Rio De Janeiro, Brazil • Guadalajara, Mexico