



# DCA45USI

## Circuit Breaker Replacement Kit

The following instructions are intended to assist the user in the installation of the Circuit Breaker Replacement Kit for use on the DCA45USI generators in the event of a circuit breaker failure. Old-style circuit breakers are no longer available. Please read all assembly instructions before installing the kit.

### REQUIRED TOOLS

- Hand-Held Rotary Saw
- Blue Masking Tape
- Phillips Head Screwdriver
- Allen Wrench
- Ruler
- Scribe
- Vacuum (Shop Vac)
- Wire Cutter
- File
- Crimp Tool
- Black Primer Paint

### PARTS

Verify that all parts are accounted for. See Figure 1 and Table 1.

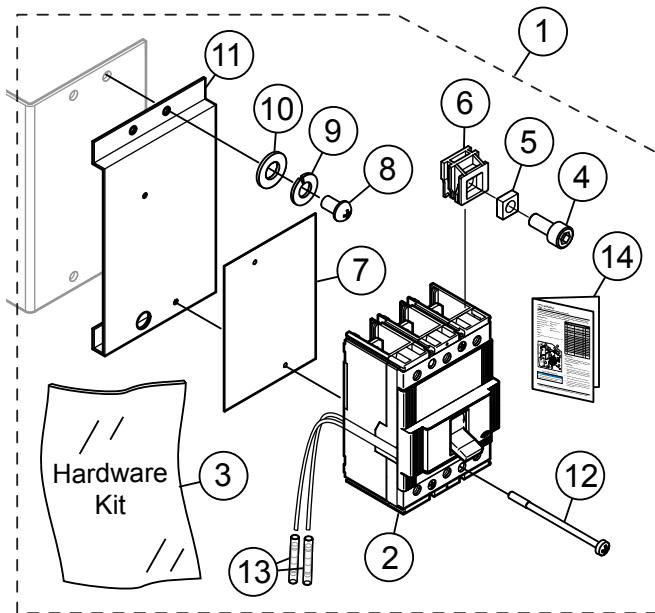

Figure 1. Return Fuel Line Kit

#### NOTICE

The Breaker Hardware Kit, item 3, includes more hardware than will be used in the procedure.

Table 1. Circuit Breaker Replacement Kit

Item No.	Part No.	Description	QTY.	Remarks
1	BREAKERKIT45USI	Breaker Update Kit, DCA45USI	1	Includes Items 2-14
2	0601807521	Circuit Breaker	1	
3	RK0001	Breaker Hardware Kit	1	Includes Items 3-12
4		Screw, Allen Head	6	
5		Nut, Square	6	
6		Holder, Nut	6	
7		Insulating Barrier	1	
8		Screw, Phillips Head	3	
9		Washer, Lock	3	
10		Washer, Flat	3	
11		Bracket, Mounting	1	
12		Screw, Phillips Head	1	
13		Butt Splice	2	
14	EE55781	Instructions, DCA45 Breaker Update		

### WORK SAFELY!

Only a **qualified service technician** with proper training should perform this installation. Follow all shop safety rules when performing this installation.

### PREPARATION

1. Make sure generator is turned off and engine is cool.
2. Place the generator in an area free of dirt and debris. Make sure it is on secure level ground with chock blocks underneath each wheel to prevent the generator from rolling.
3. Disconnect negative battery cable from the battery.
4. Open rear cabinet door to gain access to control panel.
5. Locate the two knobs at the upper corners of the control panel door. Twist knobs to unlock door from frame. See Figure 2. Pull control panel door down to a horizontal position.

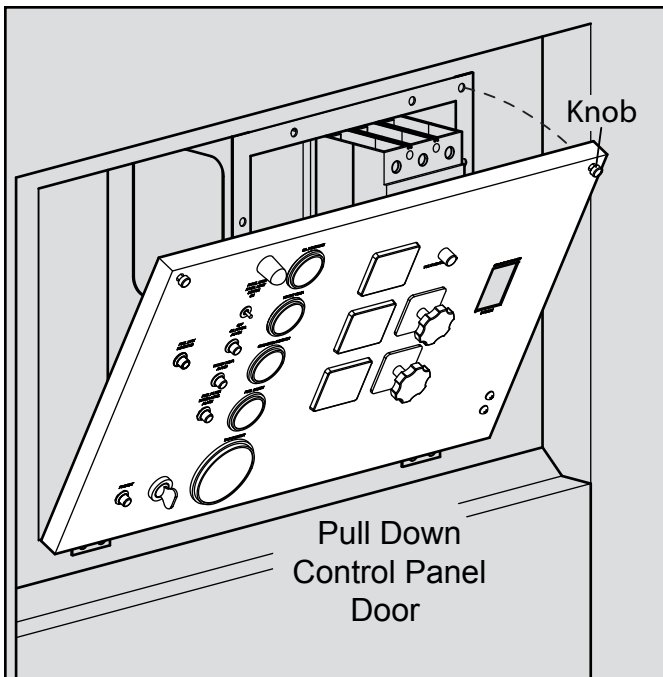

**Figure 2. Open Control Panel Door**

### DISCONNECT CIRCUIT BREAKER

1. Locate the two auxiliary wires extending from the rear of the circuit breaker. Cut wires midway between the control box and connector. See Figure 3.

#### NOTICE

The auxiliary wires are labeled as “C1” and “C2.” If visible, mark and tag wires as “C1” and “C2” prior to cutting.

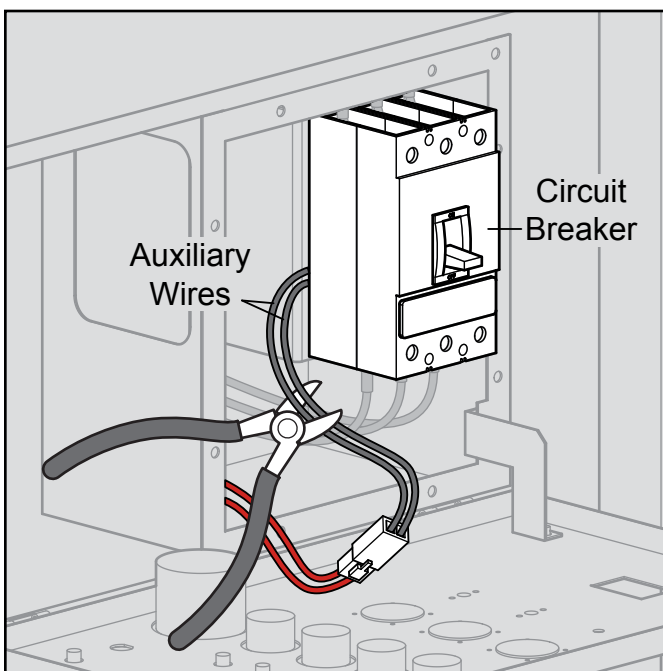

**Figure 3. Cut Auxiliary Wires**

2. Disconnect the wires from the top and bottom of the circuit breaker. Remove and discard mounting hardware that secured the wires to the circuit breaker terminals. See Figure 4.

#### NOTICE

The wires will need to be installed in the same orientation on the new circuit breaker. Mark and tag wires as necessary.

3. Disconnect the four screws securing the circuit breaker to the bracket inside the control panel. See Figure 4.
4. Remove and discard circuit breaker.

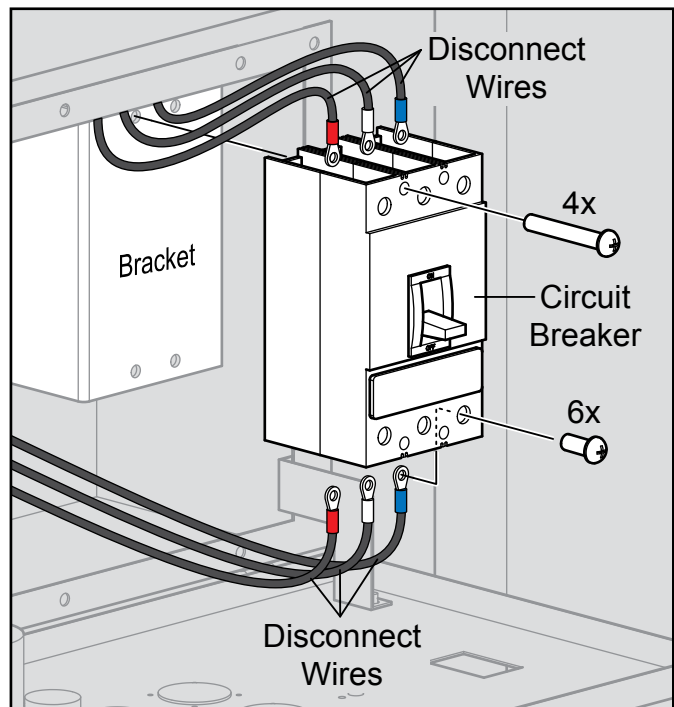

**Figure 4. Disconnect Circuit Breaker**

## MODIFY CIRCUIT BREAKER CUTOUT

The current circuit breaker cutout on the control panel door must be modified to fit the new circuit breaker.

1. Close control panel door.
2. Use a ruler and scribe to mark control panel for cutting. Refer to Figure 5 and Table 2.

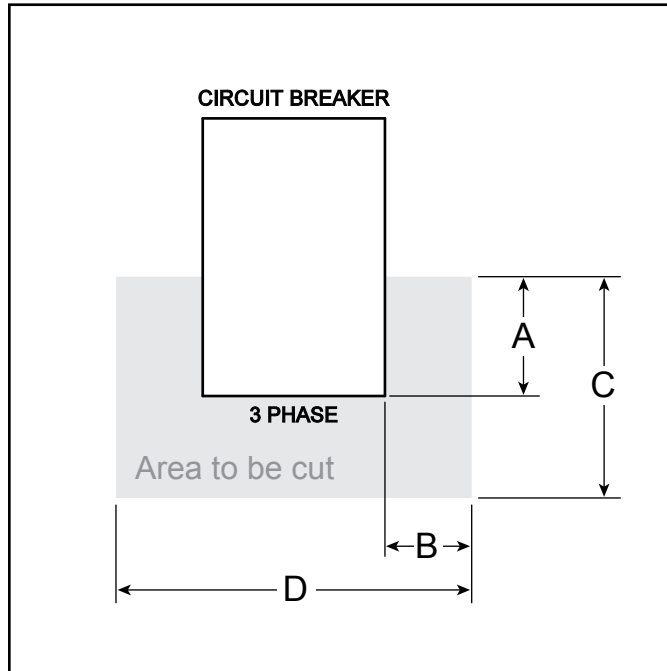

Figure 5. Cutting Guide

Table 2. Cutting Dimensions	
Reference Letter	Dimension
A	1-1/8 in (27.5 mm)
B	13/16 in. (20 mm)
C	2-1/16 in. (51 mm)
D	3-1/4 in. (82 mm)

3. Overlay scribe marks with blue masking tape.

### NOTICE

Cover all gauges on panel door and components inside control panel to protect against saw dust and debris.

4. Modify the circuit breaker cutout with a hand-held rotary saw and **metal cutting blade**. Use the blue tape as cutting guide. See Figure 6.

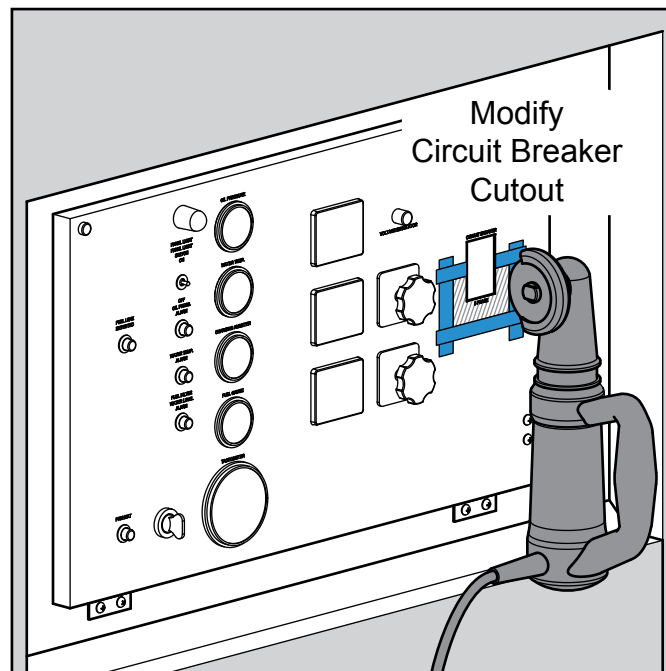
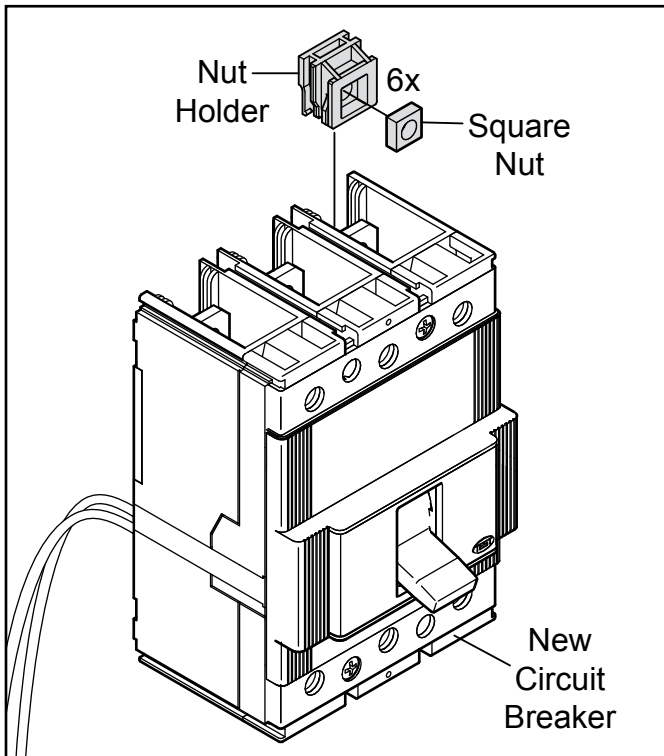

Figure 6. Modify Circuit Breaker Hole

5. De-burr rough edges with a file.
6. Use a vacuum (shop vac) to clean up all saw dust and debris on panel door and inside control panel.
7. To prevent rusting, paint exposed edges with black primer paint.

## INSTALL NEW CIRCUIT BREAKER

1. Install square nuts and nut holders (three on top, three on bottom) in new circuit breaker as referenced in manufacturer's instructions. See Figure 7.



**Figure 7. Install Square Nuts and Nut Holders**

2. Install new circuit breaker mounting bracket to existing bracket inside the control panel. Secure with phillips head screws, lock washers and flat washers in three places. See Figure 8.

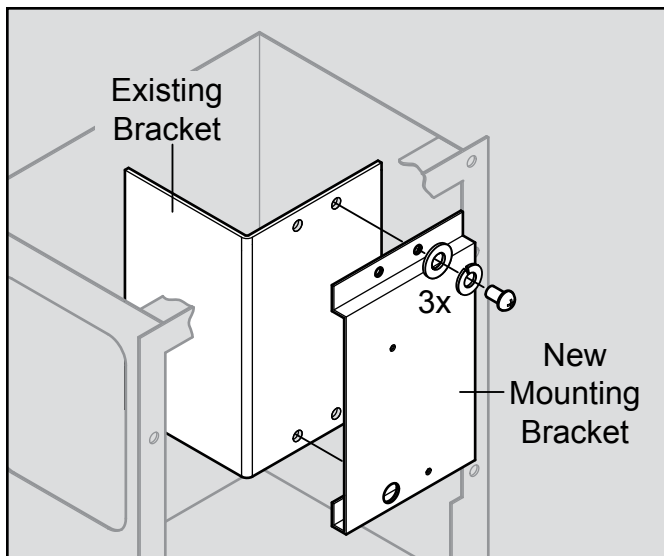

**Figure 8. Install New Mounting Bracket**

3. Secure the new circuit breaker and insulating barrier to the new mounting bracket with phillips head screws in two places. See Figure 9.

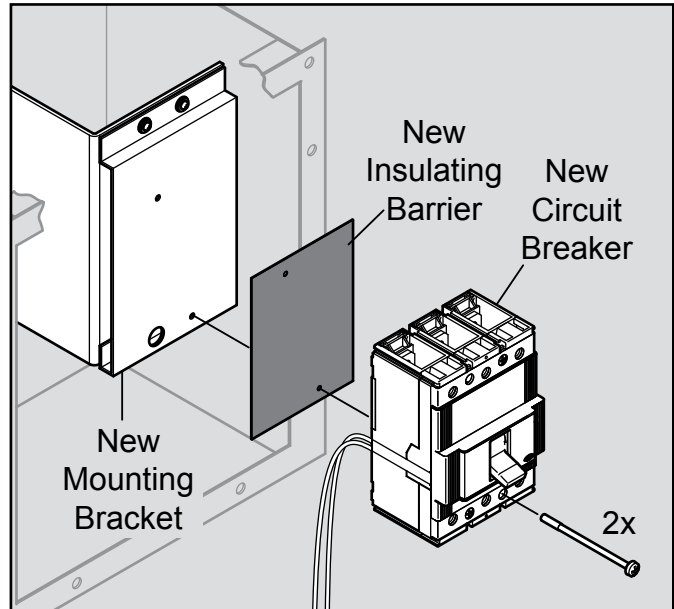

**Figure 9. Circuit Breaker Mounting Bracket**

4. Cut new circuit breaker's auxiliary wires as required to allow enough slack when spliced with the existing auxiliary wires.
5. Strip the insulation back 1/8 in. (3.2 mm) from the cut ends to expose wire conductor.
6. Place ends of new C1 wire and existing C1 wire into opposite ends of a butt splice and crimp. Repeat for C2 wires. See Figure 10.

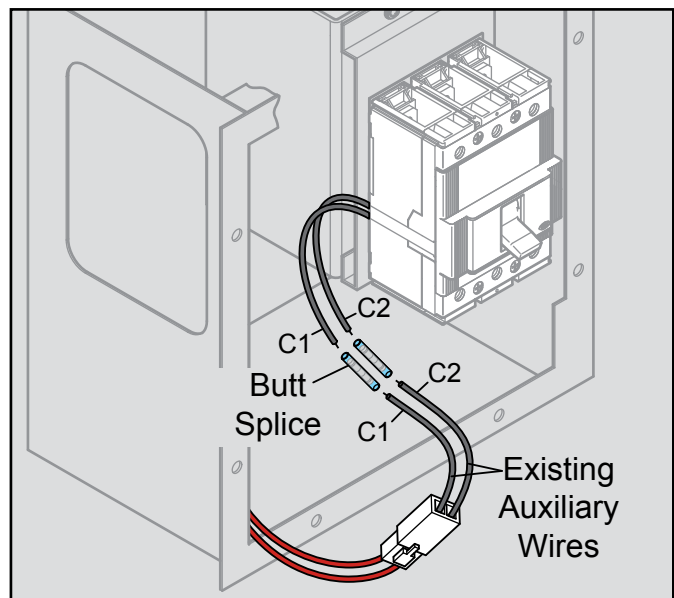
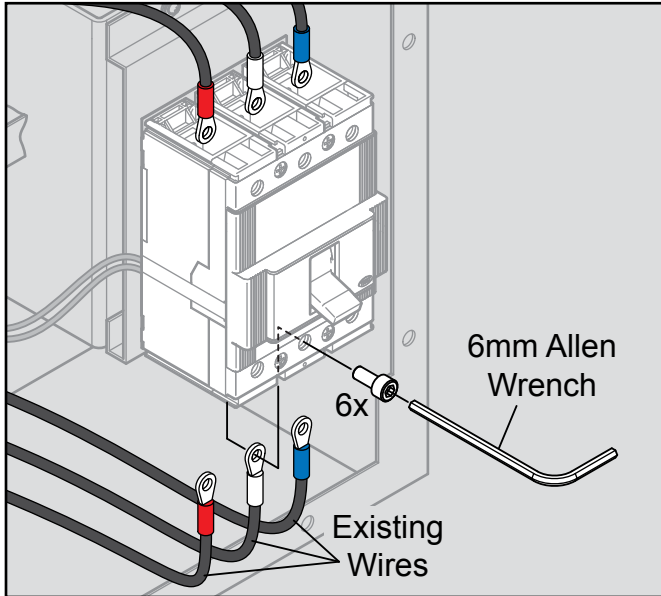

**Figure 10. Splice Auxiliary Wires**

7. Connect existing wires to the terminals on the new circuit breaker. See Figure 11. Use 6mm allen wrench to tighten screws.

### NOTICE

Make sure to install wires in the same orientation as on the old circuit breaker.



**Figure 11. Connect Wires to Terminals**

### OPERATION

1. Close control panel door.
2. Close rear cabinet door.
3. Reconnect negative battery cable.
4. Start generator as referenced in operation manual.



**DCA45USI**

**Circuit Breaker Replacement Kit**

## **HERE'S HOW TO GET HELP**

PLEASE HAVE THE MODEL AND SERIAL  
NUMBER ON-HAND WHEN CALLING

### **UNITED STATES**

#### ***Multiquip Corporate Office***

18910 Wilmington Ave. Tel. (800) 421-1244  
Carson, CA 90746 Fax (800) 537-3927  
Contact: mq@multiquip.com

#### ***Service Department***

800-421-1244 Fax: 310-537-4259  
310-537-3700

#### ***Technical Assistance***

800-478-1244 Fax: 310-943-2238

#### ***MQ Parts Department***

800-427-1244 Fax: 800-672-7877  
310-537-3700 Fax: 310-637-3284

#### ***Warranty Department***

800-421-1244 Fax: 310-943-2249  
310-537-3700

### **MEXICO**

#### ***MQ Cipsa***

Carr. Fed. Mexico-Puebla KM 126.5 Tel: (52) 222-225-9900  
Momoxpan, Cholula, Puebla 72760 Mexico Fax: (52) 222-285-0420  
Contact: pmastretta@cipsa.com.mx

### **CANADA**

#### ***Multiquip***

4110 Industriel Boul. Tel: (450) 625-2244  
Laval, Quebec, Canada H7L 6V3 Tel: (877) 963-4411  
Contact: jmartin@multiquip.com Fax: (450) 625-8664

### **UNITED KINGDOM**

#### ***Multiquip (UK) Limited Head Office***

Unit 2, Northpoint Industrial Estate, Tel: 0161 339 2223  
Globe Lane, Fax: 0161 339 3226  
Dukinfield, Cheshire SK16 4UJ  
Contact: sales@multiquip.co.uk

© COPYRIGHT 2011, MULTIQUIP INC.

Multiquip Inc and the MQ logo are registered trademarks of Multiquip Inc. and may not be used, reproduced, or altered without written permission. All other trademarks are the property of their respective owners and used with permission.

The information and specifications included in this publication were in effect at the time of approval for printing. Illustrations, descriptions, references and technical data contained in this document are for guidance only and may not be considered as binding. Multiquip Inc. reserves the right to discontinue or change specifications, design or the information published in this publication at any time without notice and without incurring any obligations.

Your Local Dealer is:

