

OPERATION AND PARTS MANUAL



MODEL DCA25SSIU WHISPERWATT™ GENERATOR (Standard)

Revision #6 (03/05/10)

To find the latest revision of this
publication, visit our website at:
www.mqpower.com



THIS MANUAL MUST ACCOMPANY THE EQUIPMENT AT ALL TIMES.



WARNING



CALIFORNIA — Proposition 65 Warning

Engine exhaust and some of its constituents are known to the State of California to cause cancer, birth defects and other reproductive harm.

Table Of Contents 4
 Parts Ordering Procedures 5
 Rules for Safe Operation 6-9
 Towing and Transportation 10
 Trailer Safety Guidelines 11-15
 Trailer Wiring Diagram 16
 Operation Decals 17-18
 DCA-25SSIU Specifications 19
 General Information 20
 Major Components 21
 Dimensions 22
 Control Panel Descriptions 24-25
 Engine Operating Panel Descriptions 26-27
 Output Terminal Panel Descriptions 28-29
 Output Amperage Setup 30-31
 Output Voltage Setup 32-35
 Installation 36-37
 Pre Setup 38-41
 Load Application 42
 Generator Start-up Procedure 43-45
 Generator Shutdown Procedure 46
 Maintenance 47-48
 Generator Wiring Diagram 50
 Engine Wiring Diagram 51
 Engine Troubleshooting 52-53
 Generator/Engine Troubleshooting 54
 Explanation of Codes in Remarks Column 56
 Suggested Spare Parts 57

ISUZU C240 ENGINE

Cylinder Head and Cover Assembly 86-87
 Cylinder Block Assembly 88-89
 Timing Gear Assembly 90-91
 Flywheel Housing Assembly 92-93
 Oil Pan Assembly 94-95
 Oil Pump Assembly 96-97
 Crankshaft, Bridge and Flywheel Assembly 98-99
 Oil and Fuel Filter Assembly 100-101
 Oil Pipe Assembly 102-103
 Water Pump and Fan Assembly 104-105
 Intake and Exhaust Manifold Assembly 106-107
 Air Cleaner Assembly 108-109
 Engine Foot Assembly 110-111
 Injection Pump Assembly 112-113
 Electrical Parts Assembly 114-115
 Accessories 116-117
 Injection Pump Comp. Assembly 118-121
 Governor Comp. Assembly 122-127
 Feed Pump Comp. Assembly 128-129
 Auto Timer Assembly 130-131
 Nozzle Holder Comp. Assembly 132-133
 Starter Comp. Assembly 134-135
 Alternator Comp. Assembly 136-139
 Terms and Conditions of Sales 140

**MQ POWER DCA-25SSIU
AC GENERATOR**

Generator Assembly 58-59
 Control Box Assembly 60-61
 Engine & Radiator Assembly 62-67
 Engine Operating Panel Assembly 68-69
 Output Terminal Assembly 70-71
 Battery Assembly 72-73
 Muffler Assembly 74-75
 Fuel Tank Assembly 76-77
 Enclosure Assembly 78-81
 Rubber Seal Assembly 82-83
 Name Plate And Decals 84-85

NOTE

*Specification and part number
are subject to change without
notice.*

PARTS ORDERING PROCEDURES

Ordering parts has never been easier! Choose from three easy options:

Effective:
January 1st, 2006

www.mqpower.com



Order via Internet (Dealers Only):

Order parts on-line using Multiquip's SmartEquip website!

- View Parts Diagrams
- Order Parts
- Print Specification Information



If you have an MQ Account, to obtain a Username and Password, E-mail us at: parts@multiquip.com.

To obtain an MQ Account, contact your District Sales Manager for more information.

Goto www.multiquip.com and click on **Order Parts** to log in and save!

Use the **internet** and qualify for a **5% Discount** on *Standard orders* for all orders which include complete part numbers.*

Note: Discounts Are Subject To Change



Order via Fax (Dealers Only):

All customers are welcome to order parts via Fax.

Domestic (US) Customers dial:
1-800-6-PARTS-7 (800-672-7877)

Fax your order in and qualify for a **2% Discount** on *Standard orders* for all orders which include complete part numbers.*

Note: Discounts Are Subject To Change



Order via Phone: Domestic (US) Dealers Call:
1-800-427-1244

Non-Dealer Customers:

Contact your local Multiquip Dealer for parts or call 800-427-1244 for help in locating a dealer near you.



International Customers should contact their local Multiquip Representatives for Parts Ordering information.

When ordering parts, please supply:

- | | |
|---|--|
| <input type="checkbox"/> Dealer Account Number | <input type="checkbox"/> Specify Preferred Method of Shipment: |
| <input type="checkbox"/> Dealer Name and Address | <input checked="" type="checkbox"/> UPS/Fed Ex <input checked="" type="checkbox"/> DHL |
| <input type="checkbox"/> Shipping Address (if different than billing address) | <input type="checkbox"/> Priority One <input checked="" type="checkbox"/> Truck |
| <input type="checkbox"/> Return Fax Number | <input type="checkbox"/> Ground |
| <input type="checkbox"/> Applicable Model Number | <input type="checkbox"/> Next Day |
| <input type="checkbox"/> Quantity, Part Number and Description of Each Part | <input type="checkbox"/> Second/Third Day |

NOTICE

All orders are treated as *Standard Orders* and will ship the same day if received prior to 3PM PST.

WE ACCEPT ALL MAJOR CREDIT CARDS!



CAUTION:



Failure to follow instructions in this manual may lead to serious injury or even death! This equipment is to be operated by trained and qualified personnel only! This equipment is for industrial use only.

The following safety guidelines should always be used when operating the DCA-25SSIU portable generator:

GENERAL SAFETY

- **DO NOT** operate or service this equipment before reading this entire manual.



- This equipment should not be operated by persons under 18 years of age.

- **NEVER** operate this equipment without proper protective clothing, shatterproof glasses, steel-toed boots and other protective devices required by the job.



- **NEVER** operate this equipment when not feeling well due to fatigue, illness or taking medicine.



- **NEVER** operate this equipment under the influence of drugs or alcohol.



- **NEVER** use accessories or attachments, which are not recommended by MQ Power for this equipment. Damage to the equipment and/or injury to user may result.

- Manufacturer does not assume responsibility for any accident due to equipment modifications.

- Whenever necessary, replace nameplate, operation and safety decals when they become difficult read.

- Always check the machine for loosened threads or bolts before starting.

- **NEVER** touch the hot exhaust manifold, muffler or cylinder. Allow these parts to cool before servicing engine or generator.



- **High Temperatures** – Allow the engine to cool before adding fuel or performing service and maintenance functions. Contact with *hot* components can cause serious burns.

- The engine of this generator requires an adequate free flow of cooling air. Never operate the generator in any enclosed or narrow area where free flow of the air is restricted. If the air flow is restricted it will cause serious damage to the generator or engine and may cause injury to people. The generator engine gives off DEADLY carbon monoxide gas.

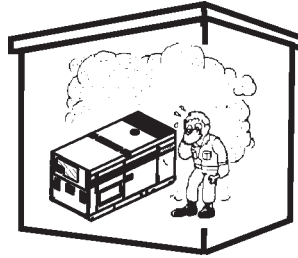

CAUTION:



- Always refuel in a well-ventilated area, away from sparks and open flames.

- Always use extreme caution when working with **flammable** liquids. When refueling, **stop the engine** and allow it to cool. **DO NOT** smoke around or near the machine. Fire or explosion could result from fuel vapors, or if fuel is spilled on a hot engine.

- **NEVER** operate the generator in an explosive atmosphere or near combustible materials. An explosion or fire could result causing severe *bodily harm or even death*.

- Topping-off to filler port is dangerous, as it tends to spill fuel.



RULES FOR SAFE OPERATION

CAUTION:

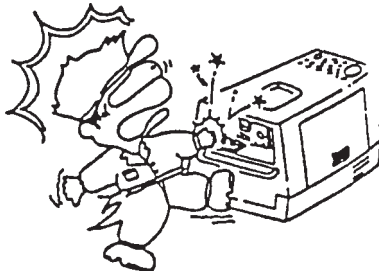

■ **NEVER** touch output terminals during operation. This is extremely dangerous. Always stop the machine when contact with the output terminals is required.

CAUTION:

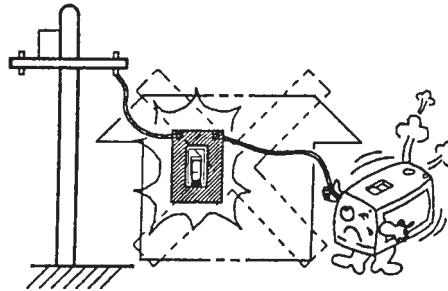

■ **Backfeed** to a utility system can cause electrocution and/or property damage. Do not connect to any building's electrical system except through an approved device or after building main switch is opened.

CAUTION:



■ **Never** use damaged or worn cables when connecting power tools or equipment to the generator. Make sure power connecting cables are securely connected to the generator's output terminals, insufficient tightening of the terminal connections may cause damage to the generator and electrical shock.

CAUTION:

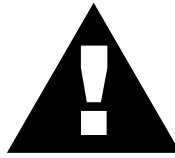

DO NOT touch or open any of the below mentioned components while the generator is running. Always allow sufficient time for the engine and generator to cool before performing maintenance.

Fluid Plugs

1. **Radiator Cap** - Removing the radiator cap while the engine is hot, will result in high pressurized, boiling water to spew out of the radiator, causing severe scalding to any persons in the general area of the generator.
2. **Coolant Drain Plug** - Removing the coolant drain plug while the engine is hot will result in hot coolant to flow out of the coolant drain plug, therefore causing severe scalding to any persons in the general area of the generator.

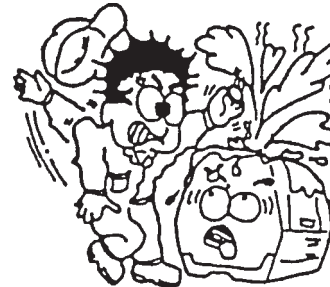

3. **Engine Oil Drain Plug** - Removing the engine oil drain plug while the engine is hot will result in hot oil to flow out of the oil drain plug, therefore causing severe scalding to any persons in the general area of the generator.

Battery

CAUTION:



Never over fill the battery with water above the upper limit.

The battery contains acids that can cause injury to the eyes and skin. To avoid eye irritation, always wear safety glasses. Use well insulated gloves when picking up the battery. Use the following guidelines when handling the battery:

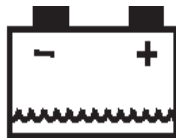

BATT. LOW LEVEL

1. **DO NOT** drop the battery. There is the possibility of risk that the battery may explode.
2. **DO NOT** expose the battery to open flames, sparks, cigarettes etc. The battery contains combustible gases and liquids. If these gases and liquids come in contact with a flame or spark, an explosion could occur.
3. Always keep the battery charged. If the battery is not charged a buildup of combustible gas will occur.
4. Always keep battery charging and booster cables in good working condition. Repair or replace all worn cables.
5. Always recharge the battery in an open air environment, to avoid risk of a dangerous concentration of combustible gases.
6. In case the battery liquid (dilute sulfuric acid) comes in contact with **clothing or skin**, rinse skin or clothing immediately with plenty of water.
7. In case the battery liquid (dilute sulfuric acid) comes in contact with your **eyes**, rinse eyes immediately with plenty of water, then contact the nearest doctor or hospital, and seek medical attention.

- **NEVER** Run engine without air filter. Severe engine damage may occur.
- Always service air cleaner frequently to prevent carburetor malfunction.
- Always disconnect the battery before performing service on the generator.
- Always be sure the operator is familiar with proper safety precautions and operations techniques before using generator.
- Always store equipment properly when not in use. Equipment should be stored in a clean, dry location out of the reach of children.
- **DO NOT** leave the generator running in the manual mode unattended.
- **DO NOT** allow unauthorized people to operate this equipment.
- Always read, understand, and follow procedures in Operator's Manual before attempting to operate equipment.
- Refer to the *Isuzu Engine Owner's Manual* for engine technical questions or information.

Loading and Unloading (Crane)

- Before lifting, make sure the generator's lifting hook is secure and that there is no apparent damage to the generator itself (loose screws, nuts and bolts). If any part is loose or damaged, please take corrective action before lifting.
- Always drain fuel prior to lifting.
- Always make sure crane or lifting device has been properly secured to the hook of guard frame on generator.
- **NEVER** lift the machine while the engine is running.
- Use adequate lifting cable (wire or rope) of sufficient strength.
- When lifting the generator, always use the balanced center-point suspension hook and lift straight upwards.
- **NEVER** allow any person or animal to stand underneath the machine while lifting.
- When loading the generator on a truck, be sure to use the front and back frame bars as a means to secure the generator during transport.

Transporting

- Always shutdown engine before transporting.
- Tighten fuel tank cap securely.
- Drain fuel when transporting generator over long distances or rough terrains.
- Always tie-down the generator during transportation by securing the generator.
- If generator is mounted on a trailer, make sure trailer complies with all local and state safety transportation laws. See page 10 for basic towing procedures.

Emergencies

- Always know the location of the nearest **fire extinguisher** and **first aid kit**. Know the location of the nearest telephone. Also know the phone numbers of the nearest **ambulance**, **doctor** and **fire department**.

Maintenance Safety

- **NEVER** lubricate components or attempt service on a running machine.
- Always allow the machine a proper amount of time to cool before servicing.
- Keep the machinery in proper running condition.
- Fix damage to the machine immediately and always replace broken parts.
- Dispose of hazardous waste properly. Examples of potentially hazardous waste are used motor oil, coolant, fuel, and fuel filters.
- **DO NOT** use plastic containers to dispose of hazardous waste.
- **DO NOT** pour waste, oil, coolant or fuel directly onto the ground, down a drain or into any water source.

DCA-25SSIU — TOWING RULES FOR SAFE OPERATION

Towing Safety Precautions

CAUTION :



Check with your county or state safety towing regulations department before towing your generator.

To reduce the possibility of an accident while transporting the generator on public roads, always make sure the trailer (Figure 1) that supports the generator and the towing vehicle are in good operating condition and both units are mechanically sound.

The following list of suggestions should be used when towing your generator:

- Make sure the hitch and coupling of the towing vehicle are rated equal to, or greater than the trailer "gross vehicle weight rating" (GVWR).
- **ALWAYS** inspect the hitch and coupling for wear. **NEVER** tow a trailer with defective hitches, couplings, chains etc.
- Check the tire air pressure on both towing vehicle and trailer. Also check the tire tread wear on both vehicles.
- **ALWAYS** make sure the trailer is equipped with a "Safety Chain".

- **ALWAYS** attach trailer's safety chain to bumper of towing vehicle.
- **ALWAYS** make sure the vehicle and trailer directional, backup, brake, and trailer lights are connected and working properly.
- The maximum speed unless otherwise posted for highway towing is **55 MPH**. It is not recommended for off-road towing. However, if necessary, do not exceed **15 MPH** or less depending on type of terrain to prevent damage to the axles.
- Place *chocked blocks* underneath wheel to prevent **rolling**, while parked.
- Place *support blocks* underneath the trailer's bumper to prevent **tipping**, while parked.
- Use the trailer's hand winch to adjust the height of the trailer, then insert locking pin to lock wheel stand in place, while parked.
- Avoid sudden stops and starts. This can cause skidding, or jackknifing. Smooth, gradual starts and stops will improve gas mileage.
- Avoid sharp turns to prevent rolling.
- Remove wheel stand when transporting.
- **DO NOT** transport generator with fuel in tank.

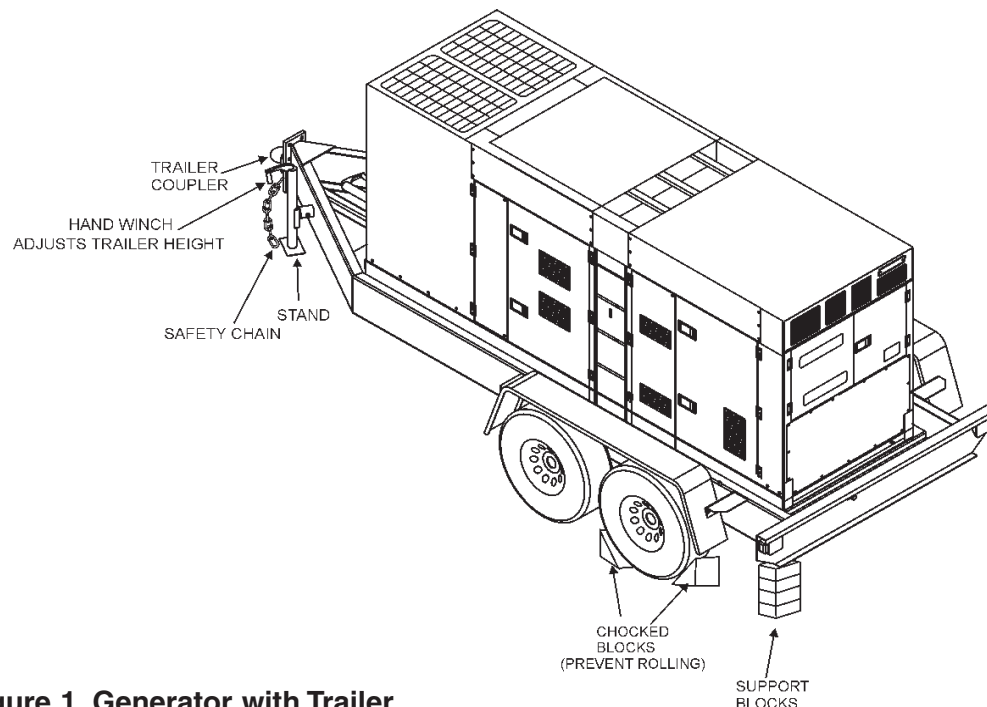

Figure 1. Generator with Trailer

CAUTION:



ALWAYS make sure the trailer is in good operating condition. Check the tires for proper inflation and wear. Also check the wheel lug nuts for proper tightness.

Explanation of Chart:

This section is intended to provide the user with trailer service and maintenance information. The service and maintenance guidelines referenced in this section apply a wide range of trailers. Remember periodic inspection of the trailer will ensure safe towing of the equipment and will prevent damage to the equipment and personal injury.

It is the purpose of this section to cover the major maintenance components of the trailer. The following trailer components will be discussed in this section:

- Tires
- Lug Nut Torquing
- Suspension
- Electrical

Use the following definitions with reading Table 1.

1. **Fuel Cell** - Provides an adequate amount of fuel for the equipment in use. Fuel cells must be empty when transporting equipment.
2. **Braking System** - System employed in stopping the trailer. Typical braking systems are electric, surge, hydraulic, hydraulic-surge and air.
3. **GVWR**- Gross Vehicle Weight Rating (GVWR), is the maximum number of pounds the trailer can carry, including the fuel cell (empty).
4. **Frame Length** - This measurement is from the ball hitch to the rear bumper (reflector).
5. **Frame Width** - This measurement is from fender to fender.
6. **Jack Stand** - Trailer support device with maximum pound requirement from the tongue of the trailer.
7. **Coupler** - Type of hitch used on the trailer for towing.
8. **Tire Size** - Indicates the diameter of the tire in inches (10,12,14, etc.), and the width in millimeters (175,185,205, etc.). The tire diameter must match the diameter of the tire rim.
9. **Tire Ply** - The tire ply (layers) number is rated in letters; 2-ply,4-ply,6-ply, etc.
10. **Wheel Hub** - The wheel hub is connected to the trailer's axle.
11. **Tire Rim** - Tires mounted on a tire rim. The tire rim must match the size of the tire.
12. **Lug Nuts** - Used to secure the wheel to the wheel hub. Always use a torque wrench to tighten down the lug nuts. See Table 4 and Figure 5 or lug nut tightening and sequence.
13. **Axle** - Indicates the maximum weight the axle can support in pounds, and the diameter of the axle expressed in inches (see Table 3). Please note that some trailers have a double axle. This will be shown as 2-6000 lbs., meaning two axles with a total weight capacity of 6000 pounds.
14. **Suspension** - Protects the trailer chassis from shocks transmitted through the wheels. Types of suspension used are leaf, Q-flex, and air ride.
15. **Electrical** - Electrical connectors (looms) are provided with the trailer so the brake lights and turn signals can be connected to the towing vehicle.
16. **Application** - Indicates which units can be employed on a particular trailer.

DCA-25SSIU — TRAILER-SPECIFICATIONS

Table 1. Specifications

| MODEL | APPLICATION | FUEL CELL | BRAKE SYSTEM | GVWR | FRAME LENGTH | FRAME WIDTH | JACK STAND |
|-------------|----------------------------------|-----------|-----------------|----------|-------------------------|-------------------|---------------------------|
| TRLR-10W | SDW225, SGW250,TLW300 | NO | NO | 1900LBS | 96" | 50" | 800LB. FULL TILT WHEEL |
| TRLR-10 | DCA10, TLG12, DCA-15 | NO | NO | 1900LBS | 96" | 50" | 800LB. FULL TILT WHEEL |
| TRLR-10XF | DCA10, TLG-12, DCA15, TLW-300 | 52 GAL | NO | 1900LBS | 96" | 50" | 800LB. FULL TILT WHEEL |
| TRLR-225W | WELDERS, DA7000SS | NO | NO | 2200LBS | 85" | 42" | 800LB. FULL TILT WHEEL |
| TRLR-BLW400 | BLW-400 | NO | ELECTRIC | 2700LBS | W/MAST 154" W/O 124" | 55" (78" TALL) | 800LB. FULL TILT WHEEL |
| TRLR-50X | DCA-25 | NO | NO | 2700LBS | 124" | 55" | 800LB. FULL TILT WHEEL |
| TRLR-50XF | DCA-25 | 41 GAL | NO | 2700LBS | 124" | 55" | 800LB. FULL TILT WHEEL |
| TRLR-70W | DCA-45, -60, 70 | NO | SURGE | 7000LBS | 186" | 77" | 2000LB. FLAT PAD |
| TRLR-70X | DCA-45, -60, 70 | OPT | SURGE | 7000LBS | 138" | 66" | 2000LB. FLAT PAD |
| TRLR-70XF | DCA-45, -60, 70 | 53 GAL | SURGE | 7000LBS | 138" | 66" | 2000LB. FLAT PAD |
| TRLR-100XF | DCA-100, 125 | 150 GAL | HYDRAULIC SURGE | 7000LBS | 190" | 76" | 2000LB. FLAT PAD |
| TRLR-85/125 | DCA-85, 100, 125 | 145 GAL | HYDRAULIC | 10000LBS | 186" | 77" | 2000LB. FLAT PAD |
| TRLR-150XF | DCA-150, 180 | 200 GAL | HYDRAULIC SURGE | 11160LBS | 204" | 84" | 5000 LB. FLAT PAD |
| TRLR-220XF | DCA-220 | 250 GAL | HYDRAULIC SURGE | 14000LBS | 222" | 83" | 5000 LB. FLAT PAD |
| TRLR-300XF | DCA-300 | 250 GAL | HYDRAULIC SURGE | 18000LBS | 238" | 83" | 5000 LB. FLAT PAD |
| TRLR-400XF | DCA-400 | 350 GAL | ELECTRIC | 18000LBS | 238" | 83" | 5000 LB. FLAT PAD |
| TRLR-600XF | DCA-600, 800 | 550 GAL | AIR | 30000LBS | 384" | 96" | 5000 LB. FLAT PAD |
| TRLR-800SX | DCA-600, 800 | 550 GAL | AIR | 30000LBS | 384" | 96" | 5000 LB. FLAT PAD |

DCA-25SSIU — TRAILER-SPECIFICATIONS

Table 1. Specifications (Con't)

| MODEL | COUPLER | TIRES | WHEELS | AXLE | HUBS | SUSPENSION | ELECTRICAL |
|-----------------|--------------------------------|------------------------------|-----------|--------------------|-------|------------|-------------------------------|
| TRLR-10W | 2" BALL CLASS 2 ADJUSTABLE | 175-13C | 13"X4.50" | 2200# 2X2 | 5 LUG | 3 LEAF | 4 WIRE LOOM W/ 4 POLE FLAT |
| TRLR-10 | 2" BALL CLASS 2 ADJUSTABLE | 175-13C | 13"X4.5" | 2200#2X2 | 5 LUG | 3 LEAF | 4 POLE FLAT |
| TRLR-10XF | 2" BALL CLASS 2 ADJUSTABLE | 175-13C | 13"X4.5" | 2200#2X2 | 5 LUG | 3 LEAF | 4 POLE FLAT |
| TRLR-225W | 2" BALL CLASS 2 ADJUSTABLE | 175-13B | 13X4.5" | 2200#2X2 | 5 LUG | Q FLEX | 4 POLE FLAT |
| TRLR-BLW 400 | 2" BALL CLASS 2 ADJUSTABLE | 175-13C | 13 X 4.5" | 2200#2X2 | 5 LUG | 3 LEAF | 4 POLE FLAT |
| TRLR-50X | 2" BALL CLASS | B78-13LRC | 13"X4.50" | 3500lbs. 2-3/8" | 5 LUG | 4 LEAF | 4 POLE RUBBER FLAT |
| TRLR-50XF | 2" BALL CLASS | B78-13LRC | 13"X4.50" | 3500lbs. 2-3/8" | 5 LUG | 4 LEAF | 4 POLE RUBBER FLAT |
| TRLR-70W | 2" BALL CLASS 3" ADJUSTABLE | 205-14C BIAS (4) | 14"X5" | 3500lbs. 3" | 5 LUG | 5 LEAF | 4 POLE RUBBER FLAT |
| TRLR-70X | 2" BALL CLASS 3" ADJUSTABLE | 205-14C BIAS (4) | 14"X5" | 3500lbs 3" | 5 LUG | 5 LEAF | 4 POLE RUBBER FLAT |
| TRLR-70XF | 2" BALL CLASS 3" ADJUSTABLE | 205-14C BIAS (4) | 14"X5" | 3500lbs. 3" | 5 LUG | 5 LEAF | 4 POLE RUBBER FLAT |
| TRLR-100XF | ADJUSTABLE 2-5/6 OPT 3" EYE | 205-15C BIAS (4) | 14"X5.5" | 3500lbs 3" | 5 LUG | 5 LEAF | 4 WIRE LOOM |
| TRLR-85/125 | ADJUSTABLE 2-5/6 OPT 3" EYE | ST225/75R15D RADIAL (4) | 14"x6" | (2)-6000lbs | 6 LUG | 7 LEAF | 4 WIRE LOOM |
| TRLR-150XF | 3" BALL EYE | 750-16 E BIAS (4) | 16"X7" | (2)-6000lbs | 8 LUG | 7 LEAF | 4 WIRE LOOM |
| TRLR-220XF | 3" EYE ADJUSTABLE | ST235/85R16E RADIAL(4) | 16"X7" | (2)-7000lbs | 8 LUG | Q FLEX | 4 WIRE LOOM |
| TRLR-300XF | 3" EYE ADJUSTABLE | ST235/85R16E RADIAL(6) | 16"X7" | (2)-6000lbs | 8 LUG | Q FLEX | 4 WIRE LOOM |
| TRLR-400XF | 3" EYE ADJUSTABLE | ST235/85R16E RADIAL(6) | 16"X7" | (3)-7000lbs. | 8 LUG | Q FLEX | 4 WIRE LOOM |
| TRLR-600XF | 5TH WHEEL | ST215/75R17.5H RADIAL (8) | 16"X7" | (3)-10000lbs | 8 LUG | 7 LEAF | 6 WIRE LOOM |
| TRLR-800AR | 5TH WHEEL | ST215/75R17.5H RADIAL (8) | 16"X7" | (3)-10000lbs | 8 LUG | AIR-RIDE | 6 WIRE LOOM |

Tires/Wheels/Lug Nuts

Tires and wheels are a very important and critical components of the trailer. When specifying or replacing the trailer wheels it is important the wheels, tires, and axle are properly matched.

CAUTION:





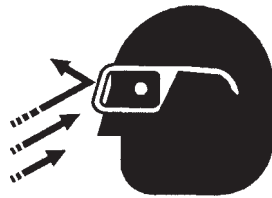



DO NOT attempt to repair or modify a wheel. DO NOT install in inner tube to correct a leak through the rim. If the rim is cracked, the air pressure in the inner tube may cause pieces of the rim to explode (break off) with great force and cause serious eye or bodily injury.



Tire Wear/Inflation

Tire inflation pressure is the most important factor in tire life. Pressure should be checked cold before operation. DO NOT bleed air from tires when they are hot. Check inflation pressure weekly during use to insure the maximum tire life and tread wear.

Table 2 (Tire Wear Troubleshooting) will help pinpoint the causes and solutions of tire wear problems.

| TABLE 2. TIRE WEAR TROUBLESHOOTING | | | |
|---|-------------|--------------------------------|---|
| WEAR PATTERN | | CAUSE | SOLUTION |
|  | Center Wear | Over Inflation. | Adjust pressure to particular load per tire manufacturer. |
|  | Edge Wear | Under Inflation. | Adjust pressure to particular load per tire manufacturer. |
|  | Side Wear | Loss of camber or overloading. | Make sure load does not exceed axle rating. Align wheels. |
|  | Toe Wear | Incorrect toe-in. | Align wheels. |
|  | Cupping | Out-of-balance. | Check bearing adjustment and balance tires. |
|  | Flat Spots | Wheel lockup & tire skidding. | Avoid sudden stops when possible and adjust brakes. |

Suspension

The leaf suspension springs and associated components (Figure 2) should be visually inspected every 6,000 miles for signs of excessive wear, elongation of bolt holes, and loosening of fasteners. Replace all damaged parts (suspension) immediately. Torqued suspension components as detailed in Table 3.

CAUTION:

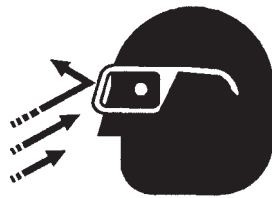

NOTE

ALWAYS wear safety glasses when removing or installing force fitted parts. Failure to comply may result in serious injury.

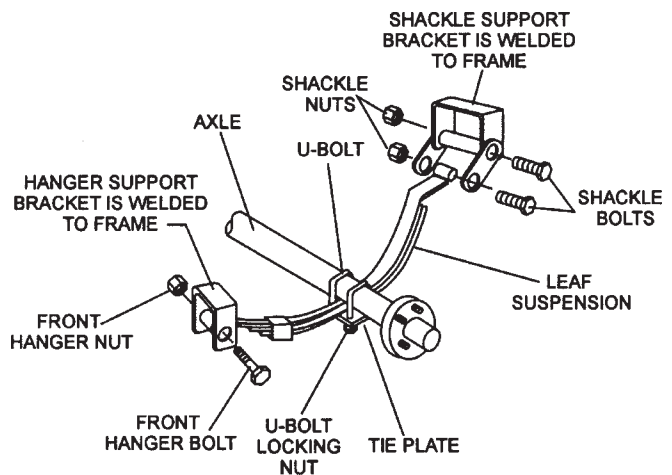

Figure 2. Major Suspension Components

Table 3. Suspension Torque Requirements

| Item | Torque (Ft.-Lbs.) |
|---------------------------------|--|
| 3/8" U-BOLT | MIN-30 MAX-35 |
| 7/16" U-BOLT | MIN-45 MAX-60 |
| 1/2" U-BOLT | MIN-45 MAX-60 |
| SHACKLE BOLT SPRING EYE BOLT | SNUG FIT ONLY. PARTS MUST ROTATE FREELY. LOCKING NUTS OR COTTER PINS ARE PROVIDED TO RETAIN NUT-BOLT ASSEMBLY. |
| SHOULDER TYPE SHACKLE BOLT | MIN-30 MAX-50 |

Lug Nut Torque Requirements

It is extremely important to apply and maintain proper wheel mounting torque on the trailer. Be sure to use only the fasteners matched to the cone angle of the wheel. Proper procedure for attachment of the wheels is as follows:

1. Start all wheel lug nuts by hand.
2. Torque all lug nuts in sequence. See Figure 3. **DO NOT** torque the wheel lug nuts all the way down. Tighten each lug nut in 3 separate passes as defined by Table 4.
3. After first road use, retorque all lug nuts in sequence. Check all wheel lug nuts periodically.

Table 4. Tire Torque Requirements

| Wheel Size | First Pass FT-LBS | Second Pass FT-LBS | Third Pass FT-LBS |
|------------|-------------------|--------------------|-------------------|
| 12" | 20-25 | 35-40 | 50-65 |
| 13" | 20-25 | 35-40 | 50-65 |
| 14" | 20-25 | 50-60 | 90-120 |
| 15" | 20-25 | 50-60 | 90-120 |
| 16" | 20-25 | 50-60 | 90-120 |

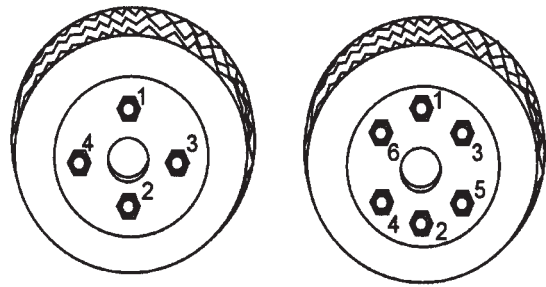

4-LUG NUTS

6-LUG NUTS

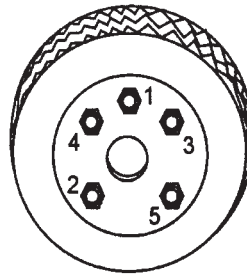

5-LUG NUTS

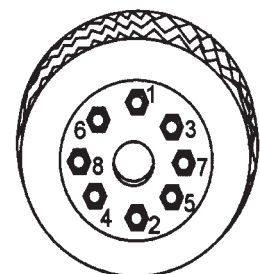

8-LUG NUTS

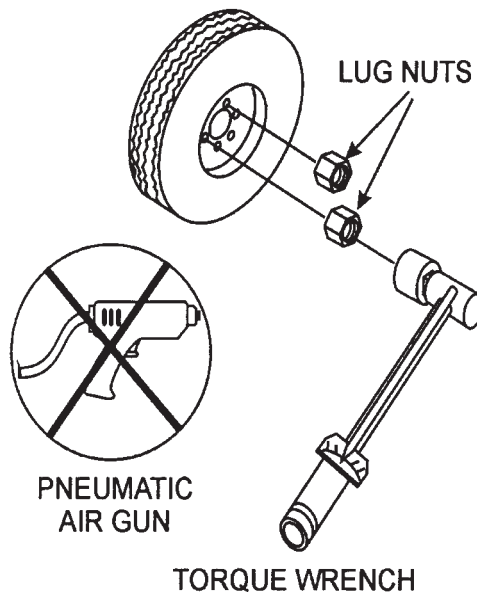
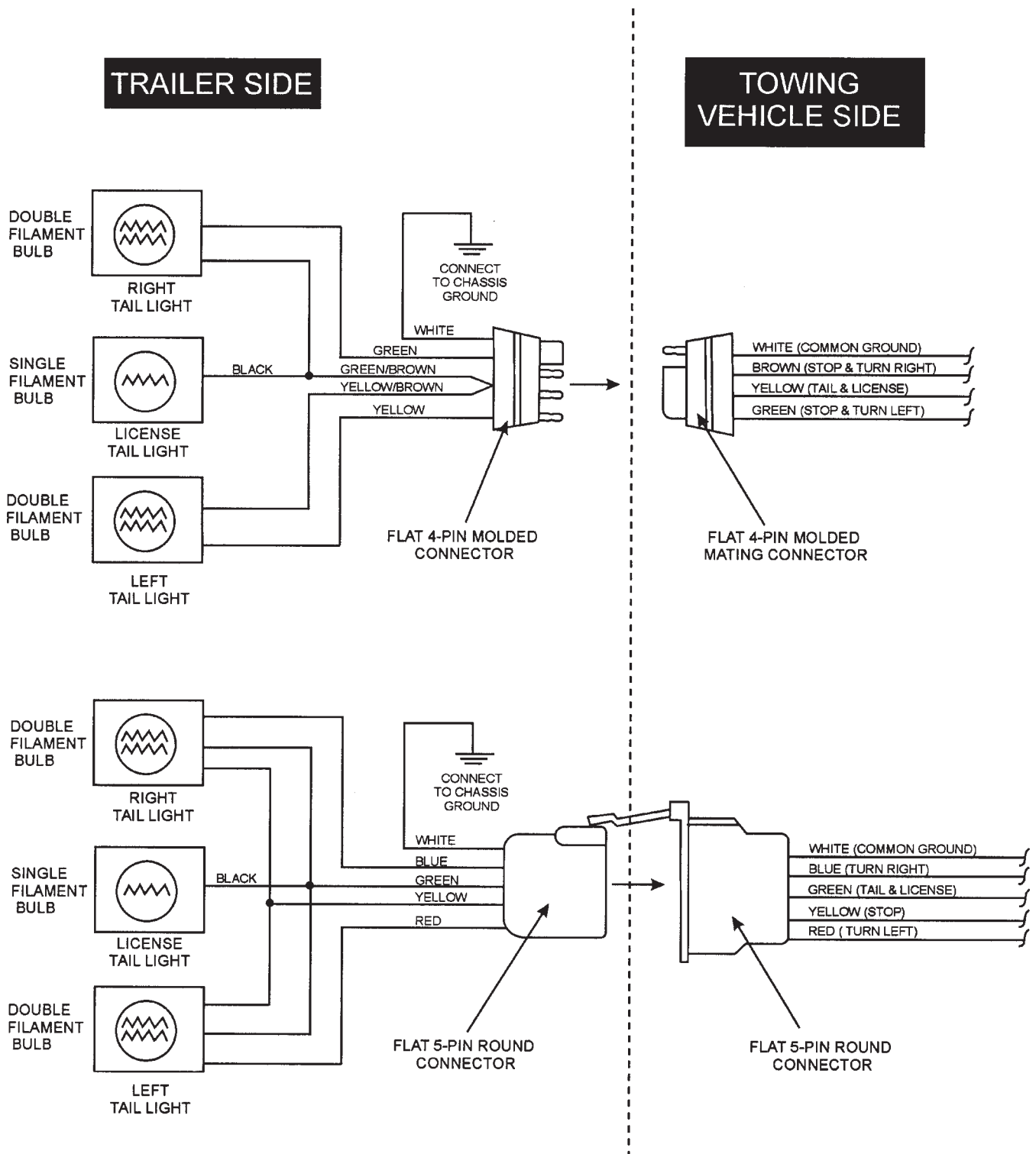

Figure 3. Wheel Lug Nuts Tightening Sequence

NOTE

NEVER use an pneumatic air gun to tighten wheel lug nuts.

DCA-25SSIU — TRAILER-WIRING DIAGRAM



NOTE:
LIGHTS ARE ORIENTED FROM THE DRIVER'S SEAT

DCA-25SSIU — GENERATOR DECALS

The DCA-25SSIU generator is equipped with a number of safety decals. These decals are provided for operator safety and maintenance information. The illustration below and on the preceding pages show the decals as they appear on the machine. Should any of these decals become unreadable, replacements can be obtained from your dealer.

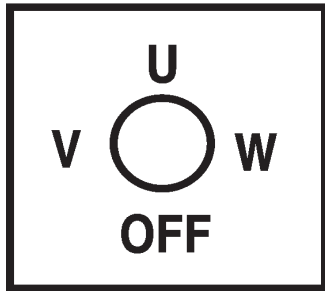

P/N M9520000104

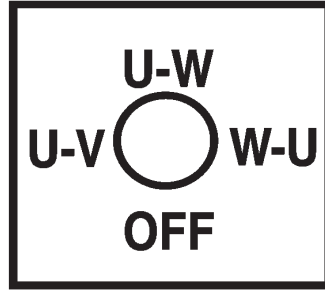

P/N M9520000204

SAFETY INSTRUCTIONS

Improper operation of this machine can cause severe injury or death.

- Read the instruction manual carefully before operating or servicing.

This machine should only be operated by a person with sufficient knowledge and skill to ensure safe operation.

High voltage circuits are located inside the output terminal cover and control panel.

- Close the cover and control panel before operating.

Moving parts and hot surfaces are contained within the enclosure.

- Close all doors and lock them before operating.

M92010030

P/N M9520100304



P/N M9510200002



P/N M9500000004



P/N M9500500004

OVER CURRENT RELAY

If it is impossible to reset the CIRCUIT BREAKER, open the control panel and push the RESET BUTTON as below.

M92020010

P/N M9520200104



P/N M9500300104



P/N M9500300004



P/N M9500500104



P/N M9503000103

| | |
|---|---|
|  | ⚠ WARNING |
| | ELECTRIC SHOCK HAZARD <ul style="list-style-type: none"> Do not touch internal wiring or connections while this machine is operating. Turn power off before servicing. |

M92010000

P/N M9520100004

| |
|---------------------|
| DANGER |
| HIGH VOLTAGE |
| M92010040 |

P/N M9520100401

| |
|---|
| NOTE |
| <p>To use 50 AMP receptacles, adjust the voltage selector switch to the single phase position and the main line circuit breaker to the on position.</p> |
| M1500020 |

P/N M1550000204

| | | | |
|---|---|--|---|
|  | ⚠ WARNING | ⚠ WARNING | ⚠ WARNING |
| | ELECTRIC SHOCK HAZARD <ul style="list-style-type: none"> Do not touch output terminals while this machine is operating. Turn power off before servicing. | ELECTRIC SHOCK HAZARD <ul style="list-style-type: none"> Always complete the grounding path from the ground terminal on this genset to an external grounding source. See instruction manual for details. | <ul style="list-style-type: none"> Before connecting this generator to any building's electrical system, a licensed electrician must install an isolation (transfer) switch. Serious injury or death may result without this transfer switch. |

M92010050

P/N M9520100503

| | |
|---|--|
|  | ⚠ WARNING |
| | HOT COOLANT can cause severe burns. <ul style="list-style-type: none"> Do not remove cap if radiator is hot. |

M90310000

P/N M9503100004

| | |
|---|--|
|  | ⚠ WARNING |
| | ENGINE EXHAUST can cause severe injury or death. <ul style="list-style-type: none"> Use only in open, well ventilated areas or vent exhaust outside. |

M90320000

P/N M9503200004

| |
|--------------------------------------|
| ⚠ CAUTION |
| <p>Stop engine before switching.</p> |
| M92010020 |

P/N M9520100204

| | |
|---|---|
|  | ⚠ CAUTION |
| | MOVING PARTS can cause severe injury. <ul style="list-style-type: none"> Do not operate with doors open. Stop engine before servicing. |

M90300000

P/N M9503000004

| | |
|---|---|
|  | ⚠ WARNING |
| | HOT PARTS can burn skin. <ul style="list-style-type: none"> Do not touch until the machine has sufficiently cooled. |

M91010000

P/N M9510100004

| | |
|---|---|
|  | ⚠ WARNING |
| | ELECTRIC SHOCK HAZARD <ul style="list-style-type: none"> Do not touch output terminals while this machine is operating. Turn power off before servicing. |

P/N M9520100503

DCA-25SSIU — SPECIFICATIONS

| Table 5. Specifications | | |
|--------------------------|---|---------------------------------------|
| Generator Specifications | | |
| Model | DCA-25SSIU | |
| Type | Revolving field, self ventilated, open protected type synchronous | |
| Armature Connection | Star with Neutral | Zig Zag |
| Phase | 3 | Single |
| Standby Output | 26.5 KVA (21.2 KW) | 15.3KW |
| Prime Output | 25 KVA (20 KW) | 14.4KW |
| Voltage | 240V or 480V | 240/120V |
| Frequency | 60 Hz | |
| Speed | 1800 rpm | |
| Power Factor | 0.8 | 1 |
| Aux. AC Power | Single Phase, 60 Hz | |
| Voltage | 120 V | |
| Output | 4.8 KW (2.4 KW x 2) | |
| Engine Specifications | | |
| Model | Isuzu QD-6(C240) | |
| Type | 4 Cycle, water-cooled, swirl combustion chamber | |
| No. of Cylinders | 4 cylinders | |
| Bore x Stroke | 3.38 in. x 4 in. (86 mm x 102 mm) | |
| Rated Output | 30.6HP/1800 rpm | |
| Displacement | 144 cu. in. (2369cc) | |
| Starting | Electric | |
| Coolant Capacity | 2.9 gal. (11 liters) | |
| Lube Oil Capacity | 1.45 gal. (5.5 liters) | |
| Fuel Consumption | 1.65 gal. (6.3L)/hr at full load | 1.3 gal. (5.0L)/hr at 3/4 load |
| | 0.9 gal. (3.4L)/hr at 1/2 load | 0.6 gal. (2.3L)/hr at 1/4 load |
| Battery | 12V- 70AH | |
| Fuel | #2 Diesel Fuel | |

DCA-25SSIU FAMILIARIZATION

Generator

The MQ Power Model DCA-25SSIU is a 20 kW **generator** that is designed as a high quality portable (requires a trailer for transport) power source for telecom sites, lighting facilities, power tools, submersible pumps and other industrial and construction machinery.

Engine Operating Panel

The "Engine Operating Panel" is provided with the following:

- Tachometer
- Water Temperature Gauge
- Oil Pressure Gauge
- Charging Ammeter Gauge
- Fuel level gauge
- Engine Throttle Lever
- Pre-Heat Light
- Alarm Lights
- Panel Light
- Panel Light Switch
- Starter Switch

Generator Control Panel

The "Generator Control Panel" is provided with the following:

- Output Voltage Adjustment Knob
- Frequency Meter (Hz)
- AC Ammeter (Amps)
- AC Voltmeter (Volts)
- Ammeter Change-Over Switch
- Voltmeter Change-Over Switch
- Main Circuit Breaker 60 amps
- Over-Current Relay

Output Terminal Panel

The "Output Terminal Panel" is provided with the following:

- Three 120V output receptacles, 50 amp
- Two 120V output receptacles, 20 amp
- 3 Circuit Breakers 240V @65 amps
- 2 GFCI Circuit Breakers 120V@ 20amps

Open Delta Excitation System

The DCA-25SSIU generator is equipped with the state of the art "**Open-Delta**" excitation system. The open delta system consist of an electrically independent winding wound among stationary windings of the AC output section.

There are four leads: A, B, C and D. During light loads, the power to the **Automatic Voltage Regulator (AVR)** is supplied from the leads parallel connections of B&C. When loads increase, the AVR switches and accepts power from leads A&D. The output of leads A&D increase proportionally with load. This of adding the voltages to each phase provides better voltage response during heavy loads.

The connections of the AVR to the AC output windings are for sensing only. No power is required from these windings.

The open-delta design provides virtually unlimited excitation current, offering maximum motor starting capabilities. The excitation does not have a "**fixed ceiling**" and responds according the demands of the required load.

Engine

The **DCA-25SSIU** is powered by a 4 cycle, water cooled, turbocharged Isuzu QD60(C640) **diesel** engine. This engine is designed to meet every performance requirement for the generator. Reference Table 5, page 19 for engine specifications.

In keeping with MQ Power's policy of constantly improving its products, the specifications quoted herein are subject to change without prior notice.

The basic controls and indicators for the DCA-25SSIU generator are addressed on the following pages.

Mechanical Governor System

The mechanical governor system control the RPM of the engine. When the engine demands increase or decrease, the mechanical governor system regulates the frequency to $\pm 5\%$. The electronic governor option limits frequency fluctuation to $\pm 0.25\%$.

DCA-25SSIU — MAJOR COMPONENTS

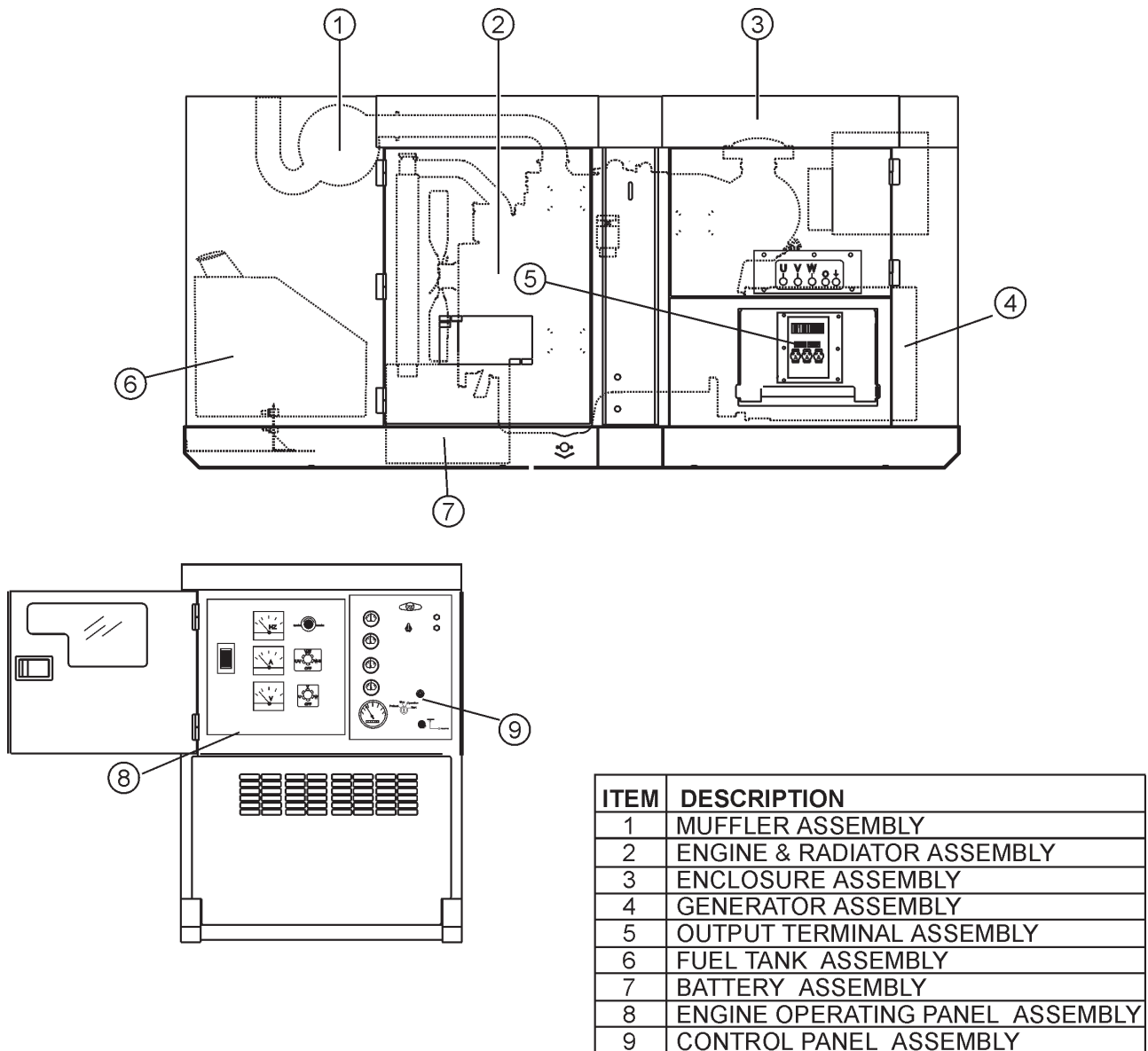

Figure 4. Major Components

DCA-25SSIU — DIMENSIONS (TOP, SIDE AND FRONT)

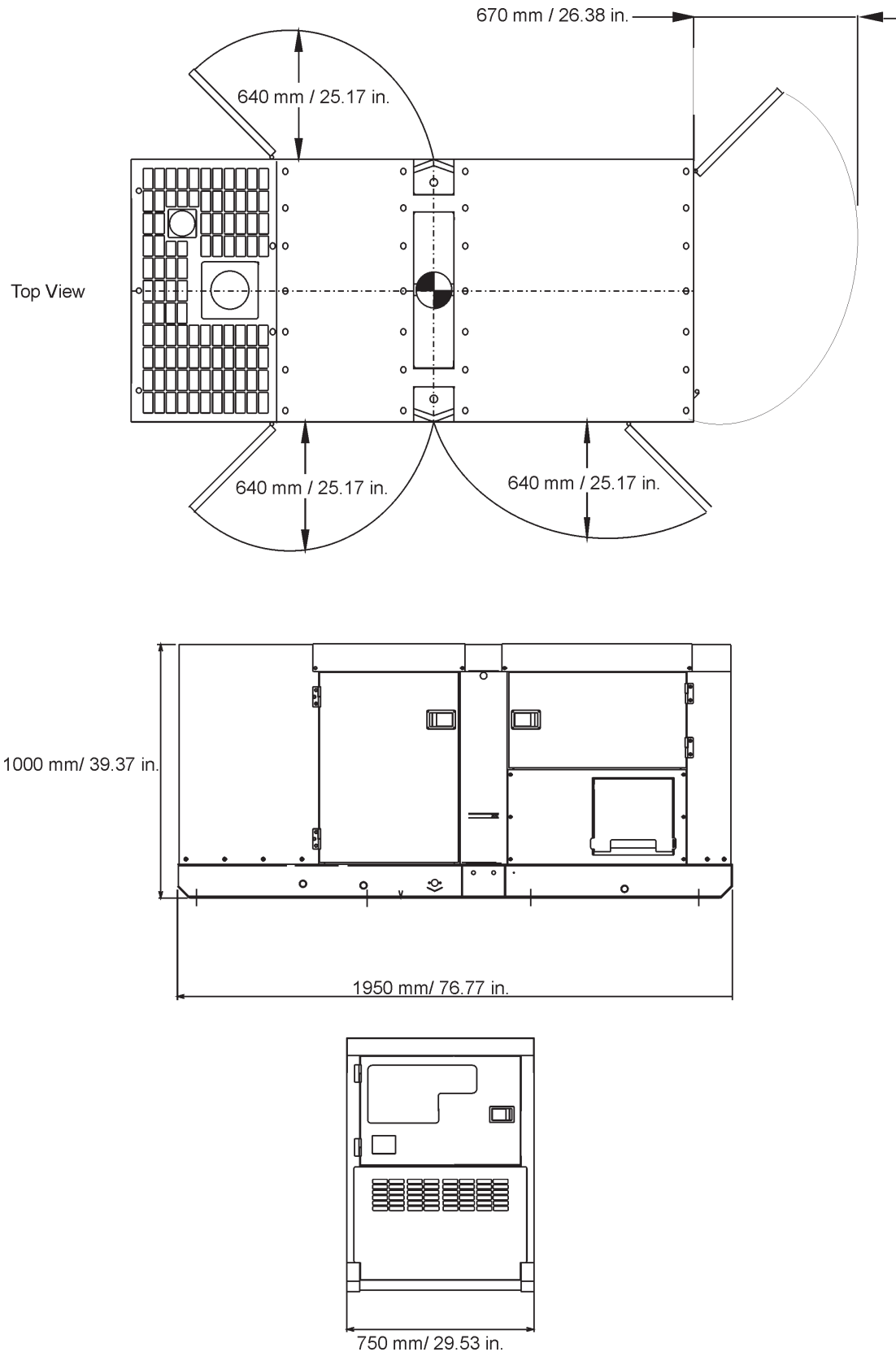
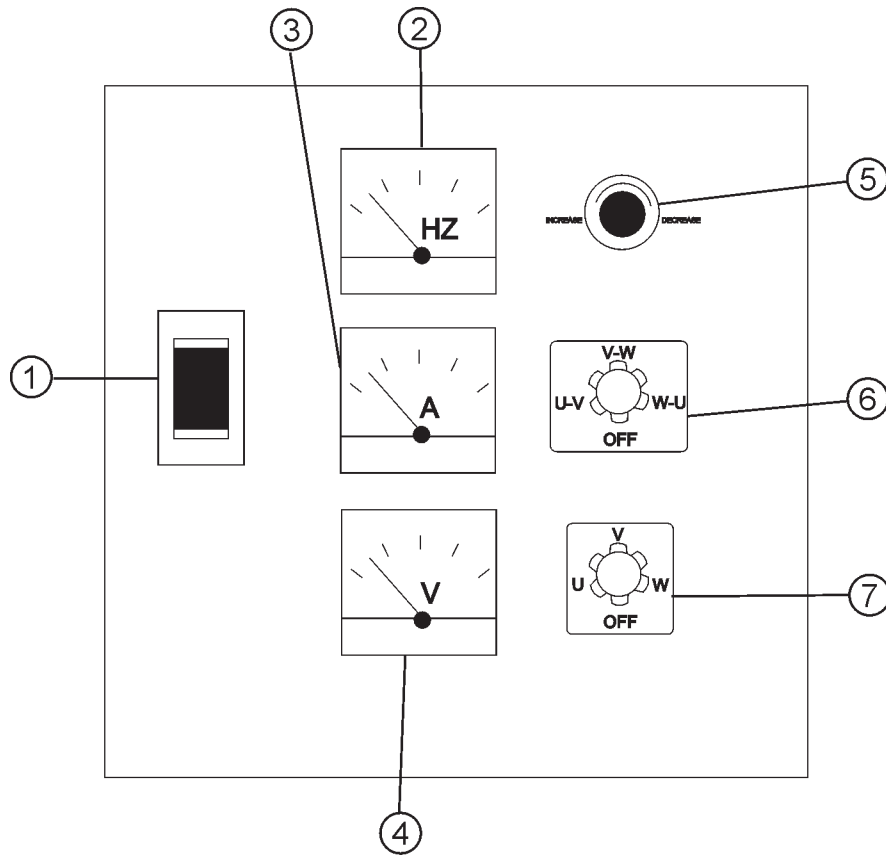

Figure 5. Dimensions



| NO | ITEM |
|----|------------------------------|
| 1 | CIRCUIT BREAKER |
| 2 | FREQUENCY METER |
| 3 | AC AMMETER |
| 4 | AC VOLTMETER |
| 5 | VOLTAGE REGULATOR |
| 6 | AMMETER CHANGE-OVER SWITCH |
| 7 | VOLTMETER CHANGE-OVER SWITCH |

Figure 6. Control Panel

The definitions below describe the controls and functions of the DCA-25SSIU " **Control Panel** " (Figure 6).

1. **Main Circuit Breaker** – This three-pole, 60 Amp main breaker is provided to protect the UNV voltage output terminals from overload.
2. **Frequency Meter** – Indicates the output frequency in hertz (Hz). Normally 63 Hz \pm 0.5 Hz .
3. **AC Ammeter** – Indicates the amount of current the load is drawing from the generator.
4. **AC Voltmeter** – Indicates the output voltage present at the UVW or output terminals.
5. **Voltage Regulator Control** – Allows manual adjustment of the generator's output voltage.
6. **Ammeter Change-Over Switch** – This switch allows the AC ammeter to indicate the current flowing to the load connected to any phase of the output terminals, or to be switched off.
7. **Voltmeter Change-Over Switch** – This switch allows the AC voltmeter to indicate phase to phase voltage between any two phases of the output terminals or to be switched off.

DCA-25SSIU — ENGINE OPERATING PANEL

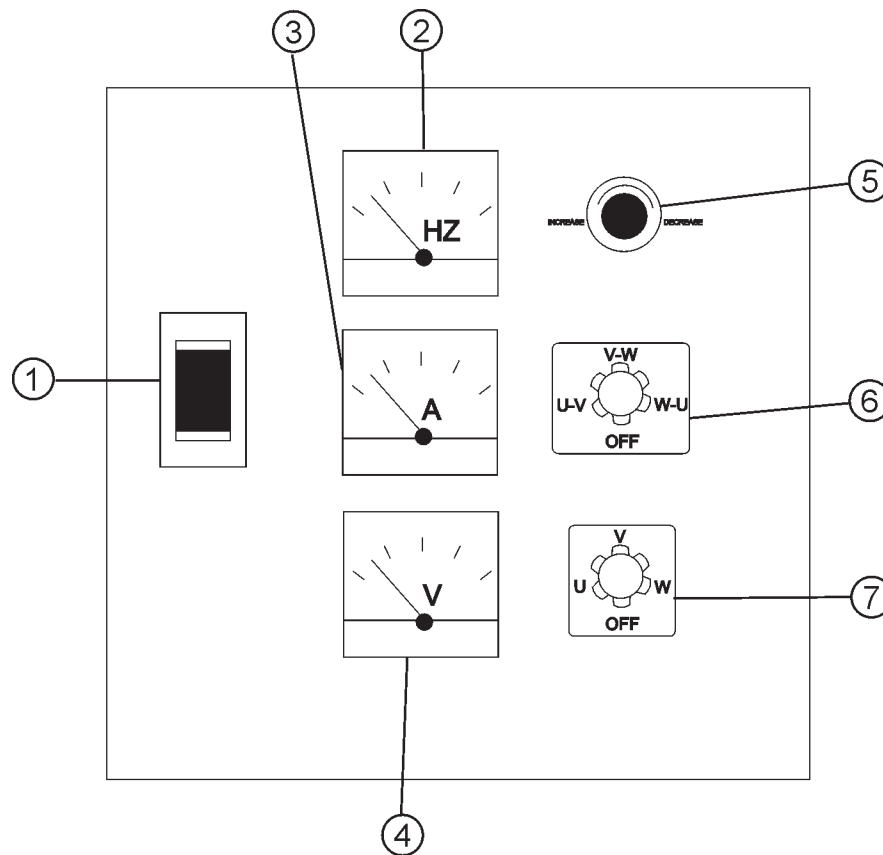

| NO | ITEM |
|----|------------------------------|
| 1 | CIRCUIT BREAKER |
| 2 | FREQUENCY METER |
| 3 | AC AMMETER |
| 4 | AC VOLTMETER |
| 5 | VOLTAGE REGULATOR |
| 6 | AMMETER CHANGE-OVER SWITCH |
| 7 | VOLTMETER CHANGE-OVER SWITCH |

Figure 7. Engine Operating Panel

The definitions below describe the controls and functions of the DCA-25SSIU " **Engine Operating Panel** " (Figure 7).

1. **Panel light** - Normally used in dark places or at night. When activated, panel will luminate. When the generator is not in use, turn the panel light switch to the 'OFF' position.
2. **Oil Pressure Lamp** - This light will luminate if the oil pressure exceeds 15 psi and will shut off the engine.
3. **Water Temperature Lamp** - This light will luminate if the water temperature exceeds 215°F and will shut off the engine.
4. **Panel light switch**- When activated, will turn on control panel light.
5. **Pre-Heat Indicator** - This light will luminate once the engine is warmed to an operating temperature.
6. **Ignition Switch** - This switch is used with a key to start, preheat, and stop the engine..
7. **Engine Throttle Lever** - To change the speed of the engine from idle to high, pull and turn the handle.
8. **Tachometer** – Indicates engine speed in RPM's for 60 Hz operation. This meter should indicate 1800 RPM's when the rated load is applied. In addition a built in hour meter will record the number of operational hours that the generator has been in use.
9. **Fuel Gauge** - Indicates amount of diesel fuel available
10. **Charging Ammeter Gauge** – Indicates the current being supplied by the engine's alternator which provides current for generator's control circuits and battery charging system.
11. **Water Temperature Gauge** – During normal operation this gauge be should read between 165° to 203°F.
12. **Oil Pressure Gauge** – Normal operation should be about 42~71 psi. When starting the generator the oil pressure may read a bit higher, but after the engine warms up the oil pressure should return to normal.

Output Terminal Panel

The output control panel is located on the rear (control panel) end of the generator. The UVW lugs are protected by a face plate cover that can be secured in the close position by a pad lock.

120 Volt Receptacle

One GFCI Duplex NEMA 5-20R (120V, 20 Amp) receptacle is located on the output terminal. This receptacle can be used anytime the generator is in operation. The receptacle is controlled by the circuit breaker located on the control panel.

The reset button will reset the receptacle after being tripped. Pressing the "Test Button" (See Figure 8) in the center of this receptacle will check the GFCI function. The receptacle should be tested at least once a month.

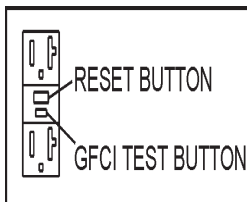

Figure 8. GFCI Test Button

Connecting Load

Loads can be connected to the generator by the UVW Lugs or the duplex receptacle. (See Figure 9). Make sure to read the operation manual before attempting to connect a load to the generator.

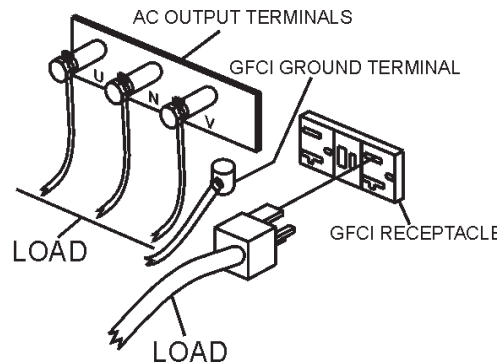

Figure 9. Connecting Loads

Circuit Breakers

To protect the generator from an overload, a 3-pole, 60 amp, **main** circuit breaker is provided to protect the UVW output terminals from overload. In addition two single-pole, 20 amp **GFCI** circuit breakers are provided to protect the GFCI receptacles from overload. Three 50 amp circuit breakers have also been provided to protect the load side of the generator from overload. Make sure to switch **ALL** circuit breakers to the "OFF" position prior to starting the engine.

Maximum Output

The entire load connected to the UVW lugs and all four slots in the duplex receptacle must not exceed 22 kW in standby or 20 kW in prime output.

120V Receptacles - These receptacles can be used anytime the generator is in operation. They are controlled by the circuit breakers above them.

Twist Lock Dual Voltage Receptacles - To use these receptacles, place the voltage selector switch in the single phase 240/120 voltage position and adjust the output voltage to 240 volts with the voltage regulator on the control panel (see Figure 6, page 24). Place the voltmeter change-over switch to the U-W position and the ammeter change-over switch to the U or W to read the output.

DCA-25SSIU — OUTPUT TERMINAL PANEL

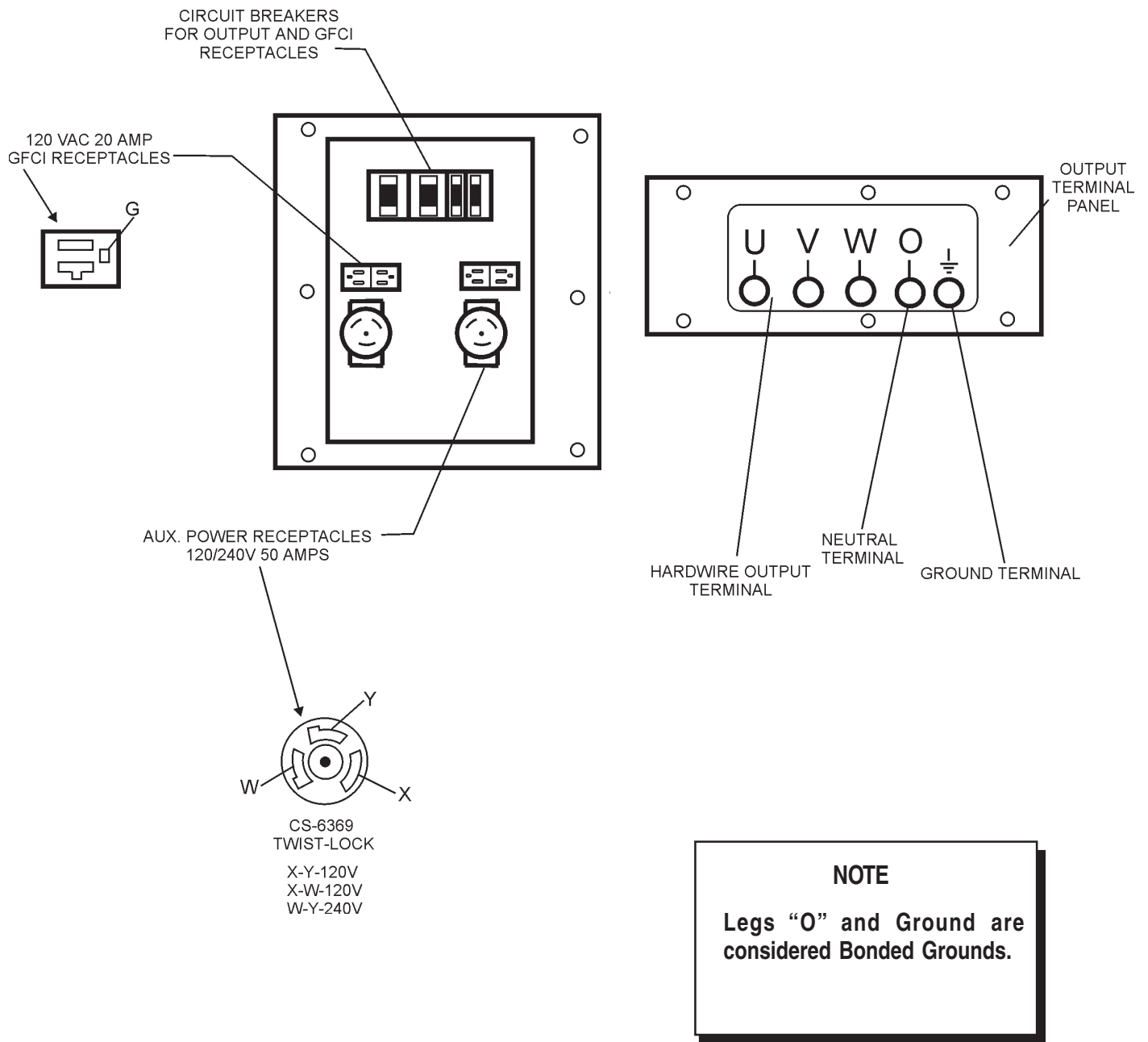

Figure 10. Output Terminal Description

DCA-25SSIU — OUTPUT AMPERAGE SETUP

Output Terminal Panel Available Voltages

A wide range of voltages are available to supply load to many different applications. Voltages may be selected by using the voltage selector switch and depending how you hookup your hard wire connection to the generator. To obtain voltages listed, fine adjustment with the voltage regulator on the control panel is necessary. See the table below (Table 6) for a list of available voltages the generator is able to supply.

Over Current Relay

An over current relay is connected to the circuit breaker. During an over current situation, both the circuit breaker and the over current relay may trip. If the circuit breaker can not be reset, the reset button on the over current relay must be pressed. The over current relay is located inside the control box.

Table 6. Voltage Available

| Table 6. Voltage Available | | | | | | |
|--------------------------------------|-----------------|-----------------|-----------------|-----------------|-----------------|-----------------|
| 3 Phase (Switchable) | 208 VOLT | 220 VOLT | 240 VOLT | 416 VOLT | 440 VOLT | 480 VOLT |
| Single Phase (Switchable) | 120 VOLT | 127 VOLT | 139 VOLT | 240 VOLT | 254 VOLT | 277 VOLT |

CAUTION :



NEVER switch the voltage selector switch position while the engine is engaged.

Voltage Selector Switch Locking Button

The voltage selector switch has a locking button to protect the generator and generator load from being switched while the engine is running. To lock the voltage selector switch, press in the red button located on the lower part of the voltage selector switch, and use a pad lock to hold it into this position.

Maximum Amps

The following table show the maximum amps the entire generator can provide. Do not exceed the maximum amps listed. (See Table 7)

Table 7. Maximum Amps

| Rated Voltage | Maximum Amps |
|--------------------------|---------------------|
| Single Phase 120 Volt | 55.5 amps (4 wire) |
| Single Phase 240 Volt | 27.8 amps (4 wire) |
| Three Phase 240 Volt | 60 amps |
| Three Phase 480 Volt | 30 amps |

DCA-25SSIU — OUTPUT AMPERAGE SETUP

Receptacle Use

When the UVWO terminals are providing power, the receptacle power available decrease. Do not exceed receptacle power available listed on Table 8.

| Table 8. Receptacle Use | | |
|-------------------------|---|----------------------------|
| Power in Use | | Receptacle Power Available |
| 240/480V 3-Phase | 240/120V Single Phase or Twist Lock CS6369 | Duplex NEMA 5-20R 120V |
| 25 | 14.4 | 0 |
| 20.8 | 13.2 | 1.2 |
| 16.7 | 12 | 2.4 |
| 12.5 | 10.8 | 3.6 |
| 8.4 | 9.6 | 4.8 |

How To Read The Output Terminal Gauges

The gauges (Figures 13 and 15) and change-over switches on the control panel **DO NOT** effect the generator output. They are to help observe how much power is being supplied produced at the UVWO legs.

When the voltage selector switch is in the 240/120V position (see Figure 11), place the AC voltmeter change-over switch to the W-U position (Figure 12) and the AC ammeter change-over switch to the U or W position (Figure 14) to read the output on the selected leg.

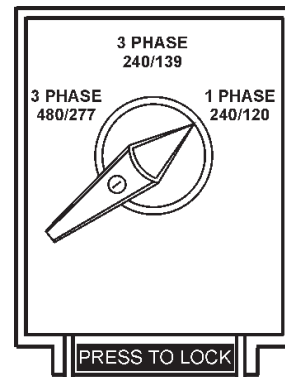

Figure 11. Voltage Selector Switch 240/120V Single Phase Position

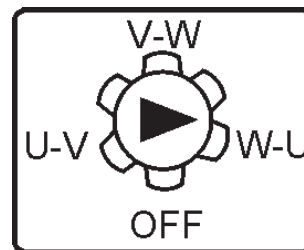

Figure 12. AC Voltmeter Change-over switch (Reading the W-U leg on the output terminal panel)

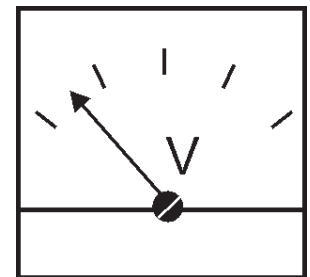

Figure 13. AC Voltmeter Gauge (Volt reading on W-U Lug)

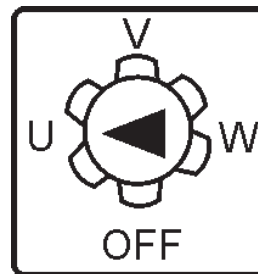

Figure 14. AC Ammeter Change-over Switch (Reading the U leg on the output terminal panel)

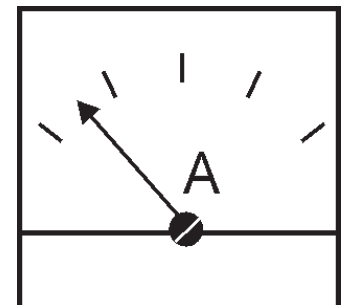

Figure 15. AC Ammeter (Amp reading on U lug)

NOTE

When using plural single phase voltages, make sure to balance the load on each of the single phase legs.

DCA-25SSIU — OUTPUT VOLTAGE SETUP

240/120V Hard Wire Hookup

With the voltage selector set and locked at 'single phase 240/120' and using single phase 120 volts, it will provide two legs available with 60 amps each (Figure 16).

When using single phase 240 volts, it will provide one leg with 60 amps available (Figure 16).

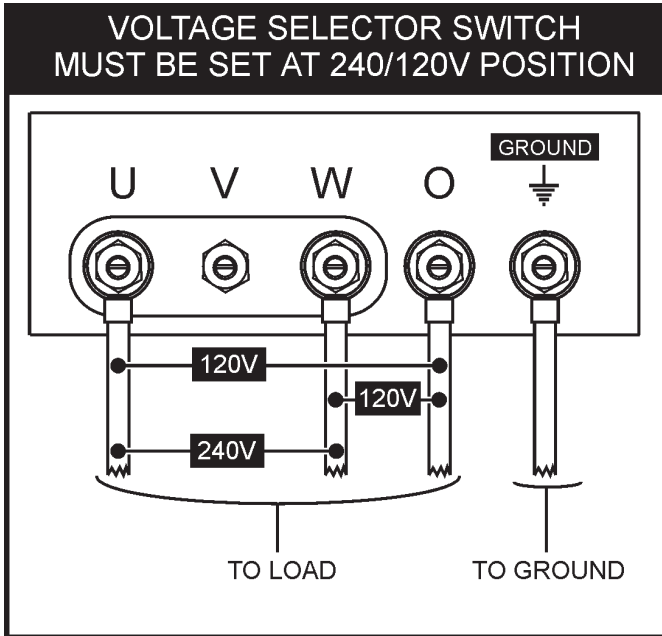

FIGURE 16. Hard Wire Hookup at 240/120V Position

480/240V Hard Wire Hookup

With the voltage selector set and locked at '3 phase 480/277' (Figure 17) and using the 3-phase 240 volt hookup, it will provide one circuit available at 108 amps with any two wires plus the ground (Figure 18).

When using the 3-phase 480 volts hookup, it will provide one circuit available at 50 amps available with all three wires plus ground (Figure 18).

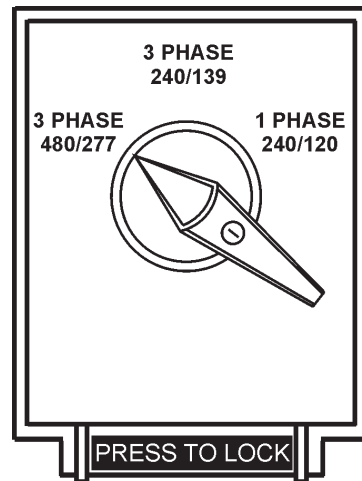

FIGURE 17. Voltage Selector Switch 480/277V Three Phase Position

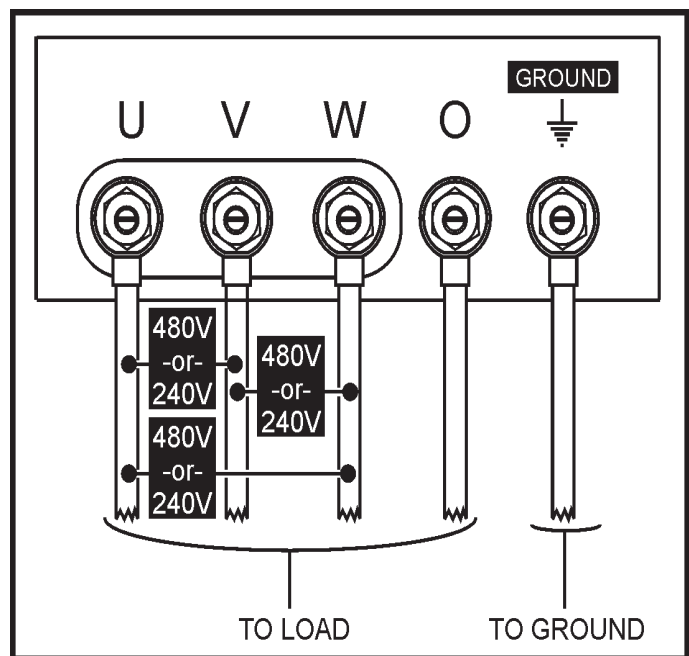

FIGURE 18. Hard Wire Hookup For 240V or 480V

Voltage Selector Switch- 3 Phase 480/277V Position

The following are additional voltages available when the voltage selector switch is in the 3 phase 480/277V position.



Figure 19. Voltage Regulator Knob

3 Phase, 480V, 440V, or 416 Volt

This setting can provide 3-phase power at 480, 440, or 416 volts. After hooking up the hard wires to the lugs as shown in Figure 20, 480 volts can be obtained the voltage regulator knob turned toward maximum; 440 volts can be obtained with the voltage regulator knob is turned down; and 416 volts can be obtained with the voltage regulator knob is at lowest setting.

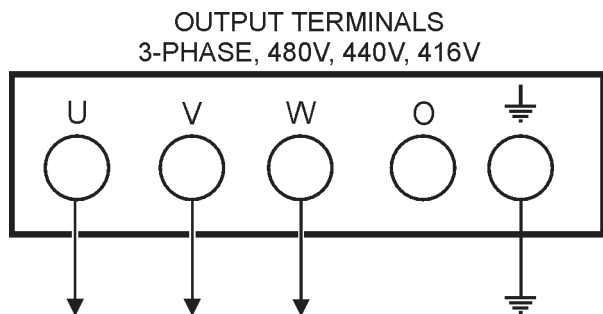

Figure 20. Hard Wire Hookup for Three Phase 480V, 440V, or 416V

Single Phase: 480V, 440V, or 416 Volt

This setting can provide single phase power at 480, 440, or 416 volts. After hooking up the hard wires to the lugs as shown in Figure 21, 480 volts can be obtained the voltage regulator knob turned toward maximum; 440 volts can be obtained with the voltage regulator knob is turned down; and 416 volts can be obtained with the voltage regulator knob is at lowest setting.

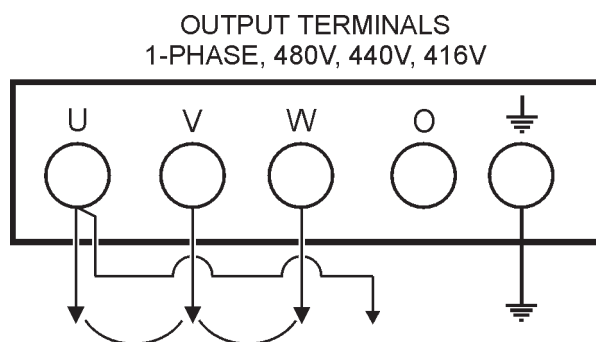

Figure 21. Hard Wire Hookup for Single Phase 480V, 440V, or 416V

Single Phase: 277V, 254V, or 240V

This setting can provide single phase power at 277, 254 or 240 volts. After hooking up the hard wires to the lugs as shown in Figure 22, 277 volts can be obtained the voltage regulator knob turned toward maximum; 254 volts can be obtained with the voltage regulator knob is turned down; and 240 volts can be obtained with the voltage regulator knob is at lowest setting.

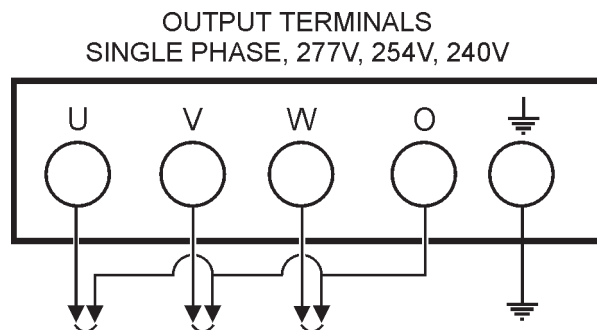

Figure 22. Hard Wire Hookup for Single Phase 277V, 254V, or 240V

Voltage Selector Switch- 3 Phase 240/139V Position

The following are additional voltages available when the voltage selector switch is in the 3 phase 240/139V position.

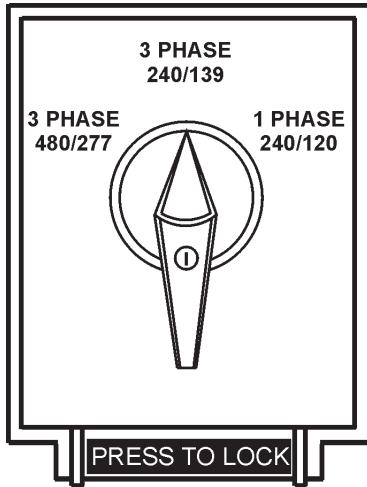

FIGURE 23. Voltage Selector Switch 240/139V Three Phase Position

3 Phase, 240V, 220V, or 208 Volt

This setting can provide 3-phase power at 240, 220, or 208 volts. After hooking up the hard wires to the lugs as shown in Figure 24, 240 volts can be obtained the voltage regulator knob turned toward maximum; 220 volts can be obtained with the voltage regulator knob is turned down; and 208 volts can be obtained with the voltage regulator knob is at lowest setting.

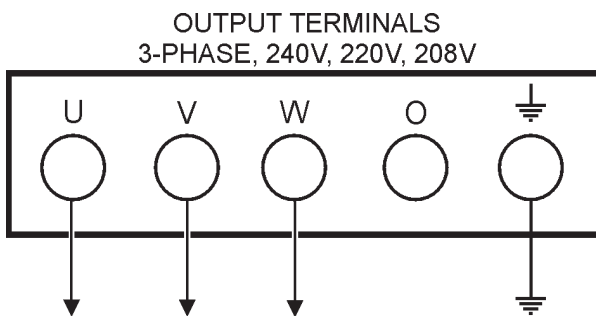

Figure 24. Hard Wire Hookup for Three Phase 240V, 220V, or 208V

Single Phase: 240V, 220V, or 208 Volt

This setting can provide single phase power at 240, 220, or 208 volts. After hooking up the hard wires to the lugs as shown in Figure 25, 240 volts can be obtained the voltage regulator knob turned toward maximum; 220 volts can be obtained with the voltage regulator knob is turned down; and 208 volts can be obtained with the voltage regulator knob is at lowest setting.

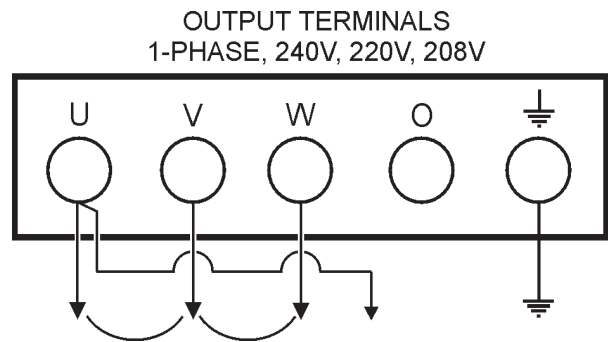

Figure 25. Hard Wire Hookup for Single Phase 240V, 220V, or 208V

Single Phase: 139V, 127V, or 120V

This setting can provide single phase power at 139, 127, or 120 volts. After hooking up the hard wires to the lugs as shown in Figure 26, 139 volts can be obtained the voltage regulator knob turned toward maximum; 127 volts can be obtained with the voltage regulator knob is turned down; and 120 volts can be obtained with the voltage regulator knob is at lowest setting.

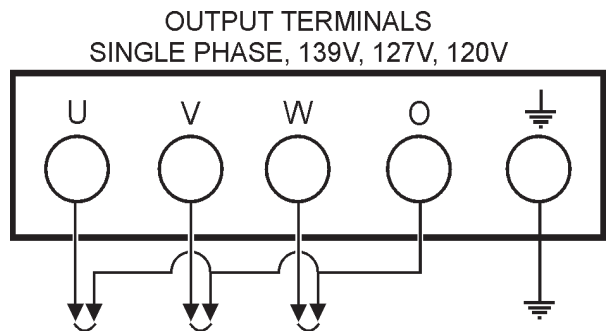

Figure 26. Hard Wire Hookup for Single Phase 139V, 127V, or 120V

Voltage Selector Switch- Single Phase 240/120V Position

The following are additional voltages available when the 240/120V position.

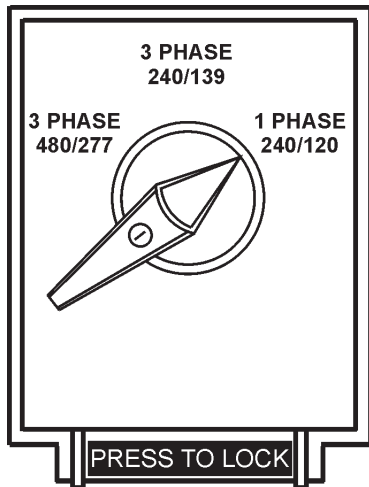

Figure 27. Voltage Selector Switch 240/120V Single Phase Position

Single Phase: 120 Volt

This setting can provide single phase power at 120 volts. After hooking up the hard wires to the lugs as shown in Figure 29, 120 volts can be obtained by using the voltage regulator to fine tune.

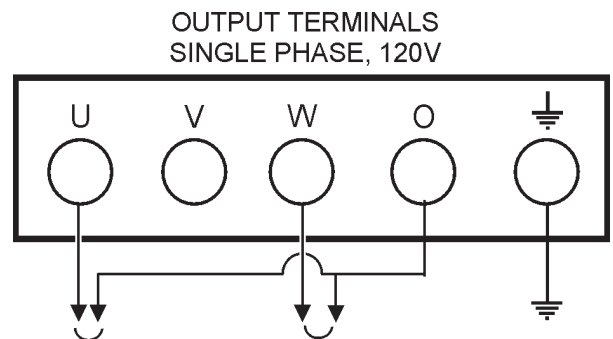

Figure 29. Hard Wire Hookup for Single Phase, 120 volt

Single Phase, 240 Volt

This setting can provide single phase power at 240 volts. After hooking up the hard wires to the lugs as shown in Figure 28, 240 volts can be obtained and using the voltage regulator to fine tune.

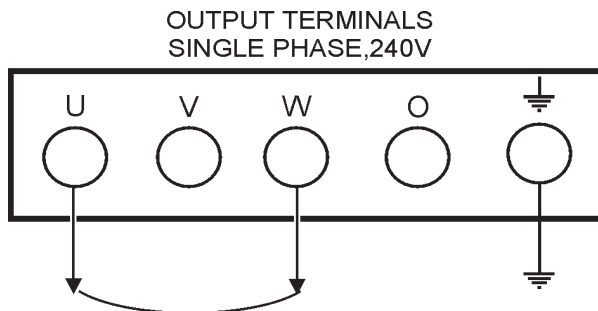

Figure 28. Hard Wire Hookup for Single Phase 240 volt

Outdoor Installation

Install the generator in a location where it will not be exposed to rain or sunshine. Make sure the generator is on secure level ground so that it cannot slide or shift around. Also install the generator in a manner so that the exhaust will not be discharged in the direction of nearby homes.

The installation site must be relatively free from moisture and dust. All electrical equipment should be protected from excessive moisture. Failure to do will result in deterioration of the insulation and will result in short circuits and grounding.

Foreign materials such as dust, sand, lint and abrasive materials have a tendency to cause excessive wear to engine and alternator parts.

CAUTION :



Pay close attention to ventilation when operating the generator inside tunnels and caves. The engine exhaust contains noxious elements. Engine exhaust must be routed to a ventilated area.

Indoor Installation

Exhaust gases from diesel engines are extremely poisonous. Whenever an engine is installed indoors the exhaust fumes must be vented to the outside. The engine should be installed at least two feet from any outside wall. Using an exhaust pipe which is too long or too small can cause excessive back pressure which will cause the engine to heat excessively and possibly burn the valves.

Mounting

The generator must be mounted on a solid foundation (such as concrete) and set firmly on the foundation to isolate vibration of the generator when it is running. The generator must set at least 6 inches above the floor or grade level (in accordance to NFPA 110, Chapter 5-4.1). DO NOT remove the metal skids on the bottom of the generator. They are to resist damage to the bottom of the generator and to maintain alignment.

CAUTION :

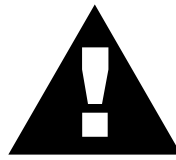

An electric shock may happen when vibrators are used. Pay close attention to handling when operating vibrators and always use rubber boots and gloves to insulate the body from electrical shock.

Generator Grounding

To guard against electrical shock and possible damage to the equipment, it is important to provide a good **EARTH** ground.

Article 250 (Grounding) of the National Electrical Code (NEC) provides guide lines for proper grounding and specifies that the cable ground shall be connected to the grounding system of the building as close to the point of cable entry as practical.

NEC articles 250-64(b) and 250-66 set the following grounding requirements:

1. Use one of the following wire types to connect the generator to earth ground.
 - a. Copper - 10 AWG (5.3 mm²) or larger.
 - b. Aluminum - 8 AWG (8.4 mm²) or larger.
2. When grounding the generator (Figure 30) connect the ground cable between the lock washer and the nut on the generator and tighten the nut fully. Connect the other end of the ground cable to earth ground.
3. NEC article 250-52(c) specifies that the earth ground rod should be buried a minimum of 8 ft. into the ground.

NOTE

When connecting the generator to any buildings electrical system **ALWAYS** consult with a licensed electrician.

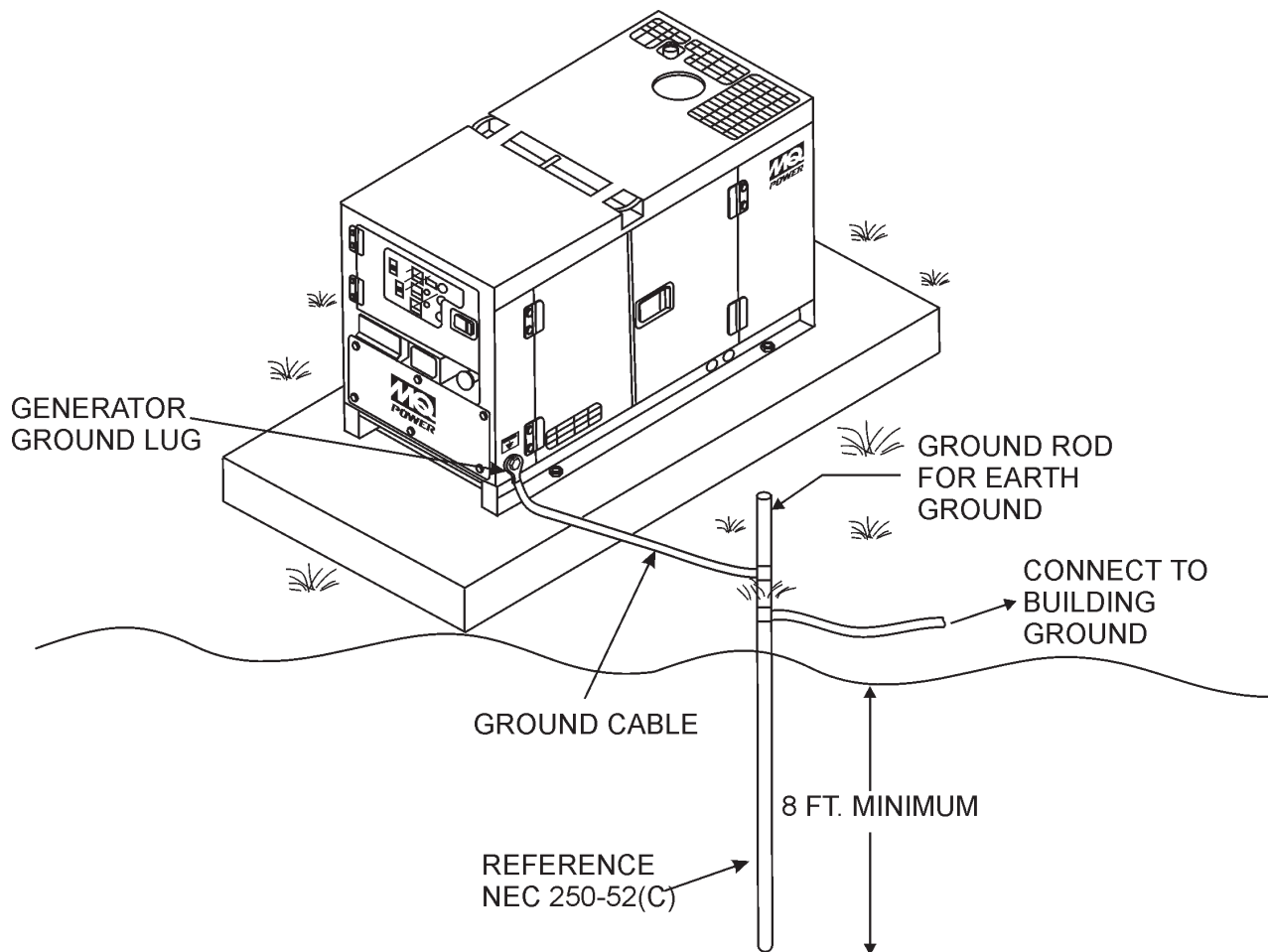

Figure 30. Typical Generator Grounding Application

General Inspection Prior to Operation

The DCA-25SSIU generator has been thoroughly inspected and accepted prior to shipment from the factory. However, be sure to check for damaged parts or components, or loose nuts and bolts, which could have occurred in transit.

Extension Cable

When electric power is to be provided to various tools or loads at some distance from the generator, extension cords are normally used. Cables should be sized to allow for distance in length and amperage so that the voltage drop between the generator and point of use (load) is held to a minimum. Use the Cable Selection Guide (Table 9) as a guide for selecting proper cable size.

Circuit Breakers

To protect the generator from an overload, a 3-pole, 60 amp, **main** circuit breaker is provided to protect the UVW output terminals from overload. In addition two single-pole, 20 amp **GFCI** circuit breakers are provided to protect the GFCI receptacles from overload. Three 50 amp **load** circuit breakers have also been provided to protect the load side of the generator from overload. Make sure to switch **ALL** circuit breakers to the "OFF" position prior to starting the engine.

NOTE

ALWAYS consult with a licensed electrician for correct extension cord wire size.

Table 9. Cable Selection (60 Hz, Single Phase Operation)

| Current in Amperes | Load In Watts | | Maximum Allowable Cable Length | | | |
|--|---------------|--------------|--------------------------------|----------|----------|----------|
| | At 120 Volts | At 240 Volts | #10 Wire | #12 Wire | #14 Wire | #16 Wire |
| 2.5 | 300 | 600 | 1000 ft. | 600 ft. | 375 ft. | 250 ft. |
| 5 | 600 | 1200 | 500 ft. | 300 ft. | 200 ft. | 125 ft. |
| 7.5 | 900 | 1800 | 350 ft. | 200 ft. | 125 ft. | 100 ft. |
| 10 | 1200 | 2400 | 250 ft. | 150 ft. | 100 ft. | |
| 15 | 1800 | 3600 | 150 ft. | 100 ft. | 65 ft. | |
| 20 | 2400 | 4800 | 125 ft. | 75 ft. | 50 ft. | |
| CAUTION: Equipment damage can result from low voltage. | | | | | | |

Lubrication Oil

Fill the engine crankcase with lubricating oil through the filler hole, but do not overfill. Make sure the generator is level. With the dipstick inserted all the way, verify that the oil level is maintained between the two notches (Figure 31) on the dipstick. See Table 10 for proper selection of engine oil. Use only CC grade or higher.

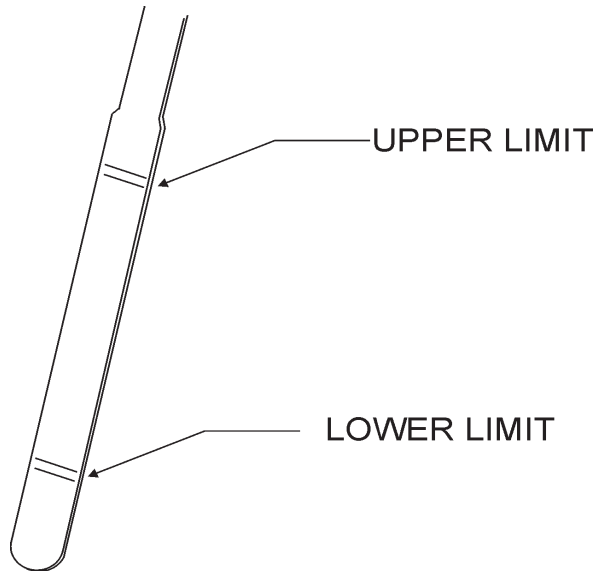

Figure 31. Engine Oil Dipstick

When checking the engine oil, be sure to check if the oil is clean and viscous. If the oil is not clean, drain the oil by removing the oil drain plug, and refill with the specified amount of oil as outlined in the **Isuzu Engine Operator’s Manual**.

Fuel

Fill the fuel tank with clean and fresh **diesel fuel**. **DO NOT** fill the tank beyond capacity.

Pay attention to the fuel tank capacity when replenishing fuel. Refer to the fuel tank capacity listed on page 19 Specification Table 5.

The fuel tank cap must be closed tightly after filling. Handle fuel in a safety container. If the container does not have a spout, use a funnel. Wipe up any spilled fuel immediately.

CAUTION :



Never fill the fuel tank while the engine is running or in the dark. Gasoline spillage on a hot engine can cause a fire or explosion. If gasoline spillage occurs, wipe up the spilled gasoline completely to prevent fire hazards.

Coolant

Use only drinkable tap water. If hard water or water with many impurities is used, the inside of the engine and radiator may become coated with deposits and cooling efficiency will be reduced. See maintenance section on page 42 and 43 on instructions to flush out radiator.

An anticorrosion additive added to the water will help prevent deposits and corrosion in the cooling system.

| Table 10. Recommended Motor Oil | |
|--|------------------------------|
| Ambient Temperature Range | Type Oil |
| -30°~0°C (-22°~32°F) | SAE 10W or SAE10W-30 |
| 0°~25°C (32°~77°F) | SAE 30 or SAE15w-40W, 20W-40 |
| Above 25°C (86°F) | SAE 40 |

CAUTION :



When adding coolant or antifreeze to the radiator, do not remove the radiator cap until the unit has completely cooled.

Day-to-day addition of coolant is done from the reserve tank. When adding coolant to the radiator, **DO NOT** remove the radiator cap until the unit has completely cooled. See Table 11. for engine, radiator, and reserve tank coolant capacities. Make sure the coolant level in the reserve tank is always between the "H" and the "L" markings.

Table 11. Coolant Capacity

| | |
|---------------------|----------------------|
| Engine and Radiator | 2.9 Gal. (11 Liters) |
| Reserve Tank | 0.27 Gal. (1 Liter) |

Operation in Freezing Weather

When operating in freezing weather, be certain the proper amount of antifreeze (Table 12) has been added.

Table 12. Anti-Freeze Operating Temperatures

| Vol % Anti-Freeze | Freezing Point | | Boiling Point | |
|----------------------|----------------|-----|---------------|-----|
| | °C | °F | °C | °F |
| 40 | -24 | -12 | 106 | 222 |
| 50 | -37 | -34 | 108 | 226 |

NOTE

When the antifreeze is mixed with water, the antifreeze mixing ratio must be less than 50%.

Cleaning the Outer Radiator

The engine may overheat if the radiator fins become overloaded with dust or debris. Periodically clean the radiator fins with compressed air. Cleaning inside the radiator is dangerous, so clean only with the engine turned off and the battery disconnected.

Air Cleaner

Periodic cleaning/replacement is necessary. Inspect it in accordance with the **Kubota Engine Owner's Manual**.

Fan Belt Tension

A slack fan belt may contribute to overheating, or to insufficient charging of the battery. Inspect the fan belt for damage and wear and adjust it in accordance with the **Kubota Engine Owner's Manual**.

The fan belt tension is proper if the fan belt bends 10 to 15 mm (Figure 32) when depressed with the thumb as shown below. Never place hands near the belts or fan while the generator is running.

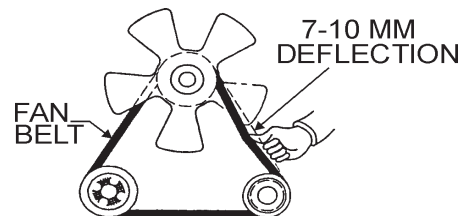

Figure 32. Fan Belt Tension

CAUTION :



Never place hands near the belts or fan while the generator set is running.

Adjusting Fan Belt

If the fan belt does not have the 10 to 15mm deflection follow the procedure below to adjust:

- Loosen the alternator adjusting plate and alternator mounting bolt.
- Pivot the alternator at the mounting bolt toward the engine left or right until the belt reflects the proper tension.
- Tighten the mounting bolt and the adjusting bolt.

Battery

This unit is of negative ground. **DO NOT** connect in reverse. Always maintain battery fluid level between the specified marks. Battery life will be shortened, if the fluid level is not properly maintained. Add only distilled water when replenishment is necessary. **DO NOT** over fill.

The battery is sufficiently charged if the specific gravity of the battery fluid is 1.28 (at 68° F). If the specific gravity should fall to 1.245 or lower, it indicates that the battery is dead and needs to be recharged or replaced.

Check to see whether the battery cables are loose. Poor contact may result in poor starting or malfunctions. Always keep the terminals firmly tightened. Coating the terminals with a thin film of grease will help to inhibit corrosion.

Battery Cable Installation

ALWAYS be sure the battery cables (Figure 33) are properly connected to the battery terminals as shown below. The **RED** cable is connected to the positive terminal of the battery, and the **BLACK** cable is connected to the negative terminal of the battery.

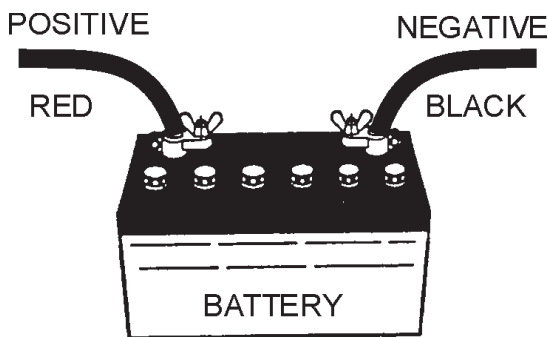
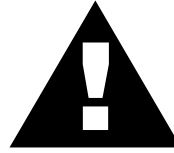

Figure 33. Battery Connections

CAUTION :



If the battery cable is connected incorrectly, damage to the generator will occur. Pay close attention to the polarity of the battery when connecting the battery.

When connecting battery do the following:

1. **DO NOT** connect the battery cables to the battery terminals when the key is in the ignition and is set in 'START' mode. **ALWAYS** remove the key from the ignition and the ignition switch is in the OFF position when connecting the battery.
2. Place a small amount of grease around both battery terminals. This will ensure a good connection and will help prevent corrosion around the battery terminals.

CAUTION :



Inadequate battery connections may cause poor starting of the generator, and create other malfunctions.

Wiring

Inspect the entire generator for bad or worn electrical wiring or connections. If any wiring or connections are exposed (insulation missing) replace wiring immediately.

Piping and Hose Connection

Inspect all piping, oil hose, and fuel hose connections for wear and tightness. Tighten all hose clamps and check hoses for leaks.

If any hose (fuel or oil) lines are defective replace them immediately.

Single Phase Load

Always be sure to check the nameplate on the generator and equipment to insure the wattage, amperage and frequency requirements are satisfactorily supplied by the generator for operating the equipment.

Generally, the wattage listed on the nameplate of the equipment is its rated output. Equipment may require 130—150% more wattage than the rating on the nameplate, as the wattage is influenced by the efficiency, power factor and starting system of the equipment.

When the voltage selector switch is in single phase (240/120V position), place the AC voltmeter change-over switch to the U-W position and the AC ammeter change over-switch to the U or W position to read the output.

NOTE

If wattage is not given on the equipment's name plate, approximate wattage may be determined by multiplying nameplate voltage by the nameplate amperage.

$$\text{WATTS} = \text{VOLTAGE} \times \text{AMPERAGE}$$

The power factor of this generator is 1.0. See Table 13. below when connecting loads.

Table 13. Power Factor By Load

| Type Of Load | Power Factor |
|---|--------------|
| Single-phase induction motors | 0.4 - 0.75 |
| Electric heaters, incandescent lamps | 1.0 |
| Fluorescent lamps, mercury lamps | 0.4 - 0.9 |
| Electronic devices, communication equipment | 1.0 |
| Common power tools | 0.8 |

Three Phase Load

When calculating the power requirements for 3-phase power use the following equation:

$$\text{KVA} = \frac{\text{VOLTAGE} \times \text{AMPERAGE} \times \sqrt{3} (1.732)}{1000}$$

CAUTION:



Motors and motor-driven equipment draw much greater current for starting than during operation.

An inadequate size connecting cable which cannot carry the required load can cause a voltage drop which can burn out the appliance or tool and overheat the cable.

- When connecting a resistance load such as an incandescent lamp or electric heater, a capacity of up to the generating set's rated output (kW) can be used.
- When connecting a fluorescent or mercury lamp, a capacity of up to the generating set's rated output (kW) multiplied by 0.6 can be used.
- When connecting an electric drill or other power tools, pay close attention to the required starting current capacity.

If wattage is not available on the equipment, approximate wattage may be determined by multiplying the nameplate voltage by the nameplate amperage for three-phase:
 $\text{WATTS} = 1.732 \times \text{VOLTAGE} \times \text{AMPERAGE}$

CAUTION:



Before connecting this generator to any building's electrical system, a licensed electrician must install an isolation (transfer) switch. Serious injury or death may result without this transfer switch.

NOTE

If output (kVA) is not given on the equipment nameplate, approximate output may be determined by multiplying voltage by amperage by $\sqrt{3}$ and 1.732.

WARNING:



The engine's exhaust contains harmful emissions. **ALWAYS** ventilate the exhaust when operating inside tunnels, excavations or buildings. Direct exhaust away from nearby personnel.

Before Starting Engine

1. Check the lubricating oil level prior to starting the engine. Make sure the generator is level. The oil level must be maintained between two notches on the dipstick.
2. When there is not enough lubricating oil, fill the crankcase with high grade motor oil. Use a high quality detergent oil classified CC or higher (See Table 8 on page 33).
3. Check the coolant level in the radiator and subtank. Replenish with antifreeze as necessary. Always maintain the coolant level between the **FULL** and **LOW** markings on the coolant container. Be sure that the radiator cap is fastened securely.
4. Check the fuel level on the fuel gauge. If fuel is low, fill the fuel tank with clean fresh unleaded automotive diesel. If diesel spillage occurs, completely wipe up the spilled fuel immediately.

Before Starting Generator and Control Panel

CAUTION:



NEVER start the engine with the **main**, **GFCI** or **load** circuit breakers in the **ON** position.

1. Be sure to disconnect the electrical load and switch the **main**, **load** and **G.F.C.I.** circuit breakers (Figure 34) to the "OFF" position prior to starting the engine.

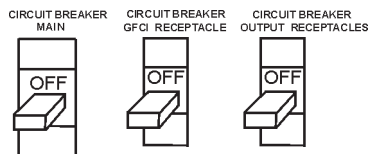

Figure 34. Main, GFCI and Load Circuit Breakers

2. Connect the load to the UVW terminals as shown in Figure 35. These terminals can be found on the output terminal panel, (see page 29 Figure 10). To gain access to the output terminals lift the UVW cover. Tighten terminal nuts securely to prevent load wires from slipping out.

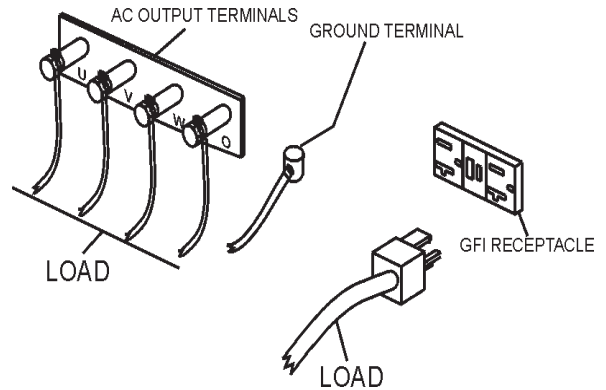

Figure 35. UVW Terminal Lugs (Load)

3. Connect the negative battery cable (BLACK) to the negative post on the battery (Figure 36).

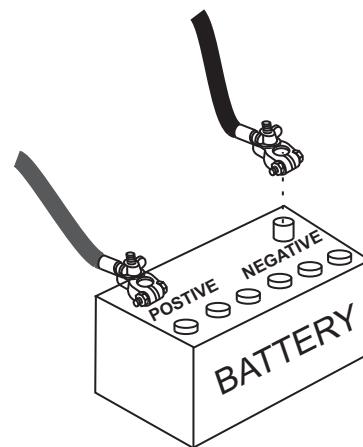

Figure 36. Battery Connections

DCA-25SSIU — GENERATOR START-UP PROCEDURE

4. Close all engine enclosure doors (Figure 37).

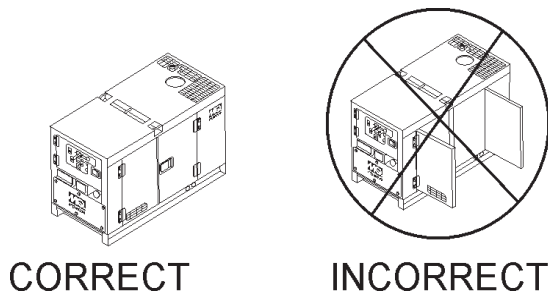

Figure 37. Engine Enclosure Doors

5. Check the voltage selection switch (Figure 38) is at the desired voltage.

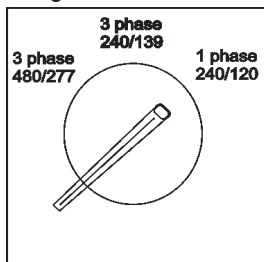

Figure 38. Voltage Selection Switch

6. Make sure the engine throttle (Figure 39) is in 'start/idle'.

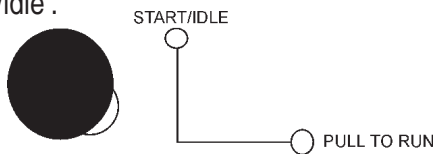

Figure 39. Engine Throttle Lever (low)

7. Turn the ignition key to preheat (Figure 40), until the preheat indicator turns on.

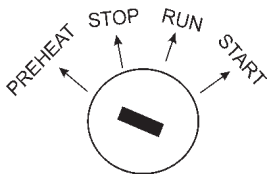

Figure 40. Ignition Switch 'PREHEAT'

8. Once the preheat indicator lights, turn the ignition key to 'START' until the engine starts (Figure 41). Then release the key to 'RUN'.

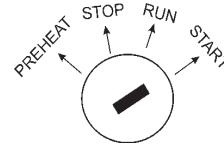

Figure 41. Ignition Switch 'START'

9. Pull the engine throttle and turn to the right until the metal stop rests against the control panel (Figure 42).

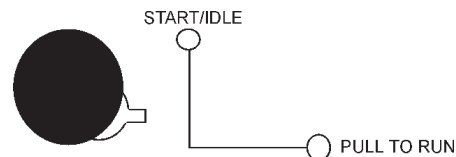

Figure 42. Engine Throttle Lever (high)

10. The generator's frequency meter (Figure 43) displays the 60 cycle output frequency in HERTZ.

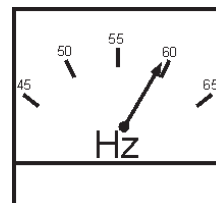

Figure 43. Frequency Meter (Hz)

11. The generator's voltage meter (Figure 44) displays the 120 VAC in VOLTS. If the voltage is not within the specified frequency tolerance, use the voltage adjustment control knob (Figure 45) to increase or decrease the desired voltage.

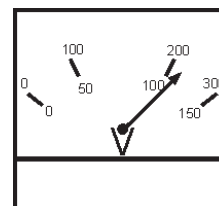

Figure 44. Voltage Meter (Volts)

DCA-25SSIU — GENERATOR START-UP PROCEDURE

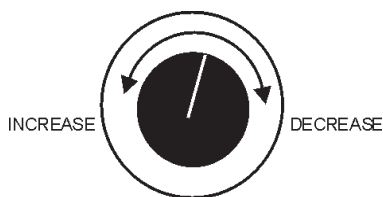

Figure 45. Voltage Adjust Control Knob

12. The ammeter (Figure 46) will indicate zero amps with no load applied. When a load is applied, this meter will indicate the amount of current that the load is drawing from the generator's alternator.

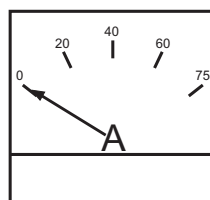

Figure 46. Ammeter (No Load)

13. The engine oil pressure gauge (Figure 47) will indicate the oil pressure (kg/cm²) of the engine. Under normal operating conditions the oil pressure is approximately 25 psi.

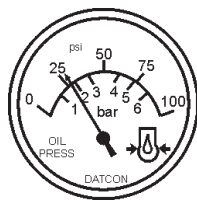

Figure 47. Oil Pressure Gauge

14. The coolant temperature gauge (Figure 48) will indicate the coolant temperature. Under normal operating conditions the coolant temperature is between 165 and 215 degrees Fahrenheit.

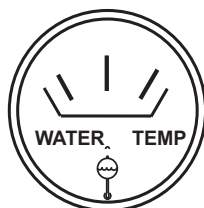

Figure 48. Coolant Temperature Gauge

15. The charging ammeter will indicate if the battery is being properly charged or if any current is being charged properly.

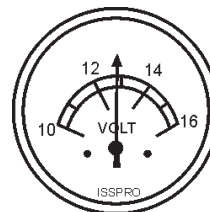

Figure 49. Charging Ammeter

16. The tachometer (Figure 50) will indicate the speed of the engine when the generator is operating. Under normal operating conditions this speed is approximately 1800 RPM's.

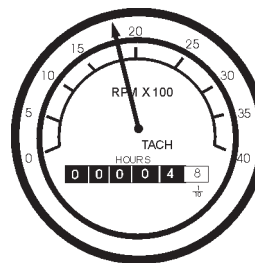

Figure 50. Engine Tachometer

17. Turn the MAIN, GFCI and LOAD circuit breakers to their ON position (Figure 51).

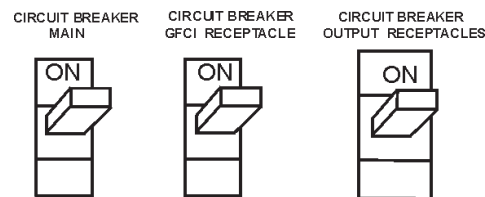

Figure 51. Main and GFCI Circuit Breakers

DCA-25SSIU — GENERATOR SHUTDOWN PROCEDURE

18. Observe the generator's ammeter (Figure 52) and verify it reads the anticipated amount of current with respect to the load. The ammeter will only display a current reading if the load is in use.

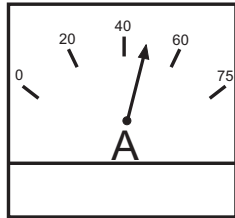

Figure 52. Ammeter (Load)

19. The generator will run until manually stopped or an abnormal condition occurs.

ENGINE SHUTDOWN

To shutdown the generator, use the following procedure:

1. Switch both the MAIN, GFCI and LOAD circuit breakers (Figure 53) to the "OFF" position.

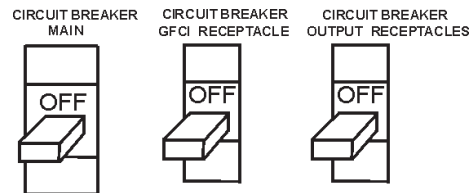

Figure 53. Main, GFCI and Load circuit breakers

2. Set the engine throttle lever to (low) position.
3. Let the engine cool by running it for 3-5 minutes with no load applied.
4. Turn the ignition key to 'STOP' (Figure 54).

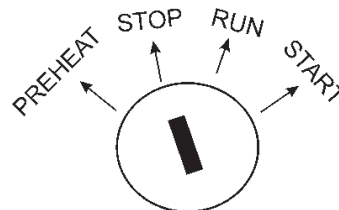

Figure 54. Ignition Switch 'STOP'

5. Remove the load from the UVW terminal strip.

General Inspection

Prior to each use, the generator should be cleaned and inspected for deficiencies. Check for loose, missing or damaged nuts, bolts or other fasteners. Also check for fuel, oil, and coolant leaks.

Engine Side (Refer to the Engine Instruction Manual)

Air Cleaner

Every 50 hours: Remove air cleaner element and clean heavy duty paper element with kerosene, or foam element with liquid detergent and hot water. Wrap foam element in a cloth and squeeze dry. For heavy duty paper element, wipe excess kerosene with towel.

Fuel Addition

Add diesel fuel (the grade may vary according to season and locations). Always pour through the mesh filter.

Removing Water from the Fuel Tank

After prolonged use, water and other impurities accumulate in the bottom of the tank. Occasionally remove the drain cock and drain the contents. During cold weather, the more empty volume inside the tank, the easier it is for water to condense. This can be reduced by keeping the tank full as much as possible.

Air Removal

If air enters the fuel injection system of a diesel engine, starting becomes impossible. After running out of fuel, or after disassembling the fuel system, bleed the system according to the following procedure.

To restart after running out of fuel, turn the switch to the "ON" position for 15-30 seconds. Try again, if needed. This unit is equipped with an automatic air bleeding system.

Service Daily

If the engine is operating in very dusty or dry grass conditions, a clogged air cleaner will result. This can lead to a loss of power, excessive carbon buildup in the combustion chamber in high fuel consumption.

Cleaning the Fuel Strainer

Clean the fuel strainer if it contains dust or water. Remove dust or water in the strainer cap and wash it in gasoline. Securely fasten the fuel strainer cap so that fuel will not leak. Check the fuel strainer every 200 hours of operation or once a month.

Check Oil Level

Check the crankcase oil level prior to each use, or when the fuel tank is filled. Insufficient oil may cause severe damage to the engine. Make sure the generator is level. The oil level must be between the two notches on the dipstick as shown in Figure 31, page 39.

Replacing Oil Filter

- Detach the oil filter cartridge with a filter wrench.
- Apply a film of oil to the gasket for the cartridge.
- Screw in the cartridge by hand. When the gasket is in contact with the seal surface, tighten the cartridge one or two more times by hand.
- After the oil cartridge has been replaced, the engine oil will drop slightly. Run the engine for a while and check for leaks before adding more oil if needed. Clean excessive oil from engine.

Replacing Fuel Filter

- Replace the fuel filter cartridge with new one every 400 hours or so.
- Apply fuel oil thinly over the gasket and hand-tighten the cartridge into position.
- Vent any air.

Flushing Out Radiator and Replacing Coolant

- Open both cocks located at the crankcase side and at the lower part of the radiator and drain coolant. Open the radiator cap while draining. Remove the overflow tank and drain.
- Check hoses for softening and kinks. Check clamps for signs of leakage.
- Flush the radiator by running clean tap water through radiator until signs of rust and dirt are removed. **DO NOT** clean radiator core with any objects, such as a screwdriver.
- Tighten both cocks and replace the overflow tank.
- Replace with coolant (see page 40, Table 12 for mixture).
- Close radiator cap tightly.

CAUTION :



Allow engine to cool when flushing out radiator. Flushing the radiator while hot will damage radiator.

Generator Storage

For storage of the generator for over 30 days, the following is required:

- Drain the fuel tank completely.
- Completely drain the oil from the crankcase and refill with fresh oil.
- Clean all external parts of the generator with a cloth.
- Cover the generating set and store in a clean, dry place.

| INSPECTION / MAINTENANCE | | 10 Hrs DAILY | 250 Hrs | 500 Hrs | 1000 Hrs |
|---------------------------|---|-----------------|---------|---------|----------|
| ENGINE | Check Engine Fluid Levels | X | | | |
| | Check Air Cleaner | X | | | |
| | Check Battery Acid Level | X | | | |
| | Check Fan Belt Condition | X | | | |
| | Check for Leaks | X | | | |
| | Check for Loosening of Parts | X | | | |
| | Replace Engine Oil and Filter *1 | | X | | |
| | Clean Air Filter | | X | | |
| | Drain Bottom of Fuel Tank | | X | | |
| | Clean Unit, Inside and Outside | | X | | |
| | Change Fuel Filter *2 | | | X | |
| | Clean Radiator and Check Coolant Protection Level | | | X | |
| | Replace Air Filter Element | | | | X |
| | Check all Hoses and Clamps | | | | X |
| Clean Inside of Fuel Tank | | | | X | |
| GENERATOR | Measure Insulation Resistance Over 3M ohms | | X | | |

*1 Replace engine oil and filter at 100 hours, first time only.

*2 Replace fuel filter at 250 Hours, first time only.

DCA-25SSIU — GENERATOR WIRING DIAGRAM

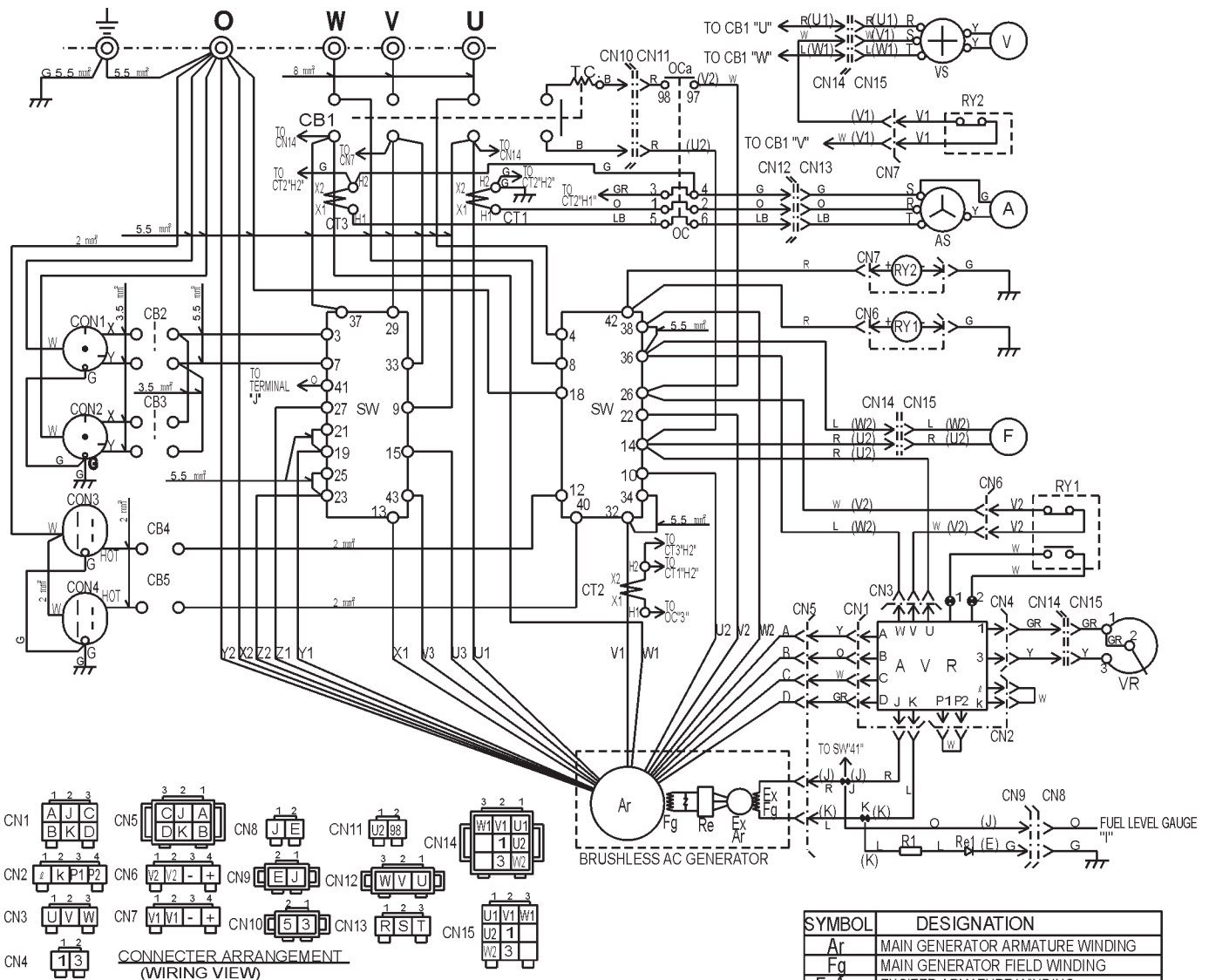

Notice
1. No designation lead size : 1.25mm²

| SYMBOL | DESIGNATION |
|----------|---------------------------------|
| Ar | MAIN GENERATOR ARMATURE WINDING |
| Fg | MAIN GENERATOR FIELD WINDING |
| ExAr | EXCITER ARMATURE WINDING |
| ExFg | EXCITER FIELD WINDING |
| Re | RECTIFIER |
| AVR | AUTOMATIC VOLTAGE REGULATOR |
| VR | VOLTAGE REGULATOR (RHEOSTAT) |
| CT 1,2,3 | CURRENT TRANSFORMER |
| AS | CHANGE-OVER SWITCH, AMMETER |
| A | AC, AMMETER |
| VS | CHANGE-OVER SWITCH, VOLTMETER |
| V | AC, VOLTMETER |
| F | FREQUENCY METER |
| CB1 | CIRCUIT BREAKER |
| CB2,3 | CIRCUIT BREAKER |
| CB4,5 | CIRCUIT BREAKER |
| CN1,2 | RECEPTACLE |
| CN3,4 | RECEPTACLE |
| OC | OVER CURRENT RELAY |
| SW | SELECTOR SWITCH |
| RY1,2 | RELAY UNIT |
| R1 | RESISTOR |
| Re1 | RECTIFIER |
| •J,K | TERMINAL |

DCA-25SSIU — ENGINE WIRING DIAGRAM

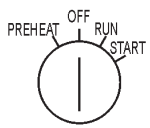
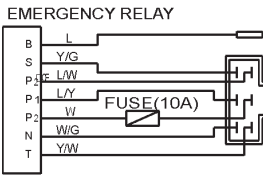
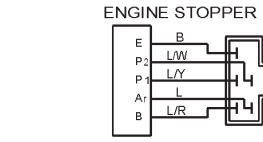
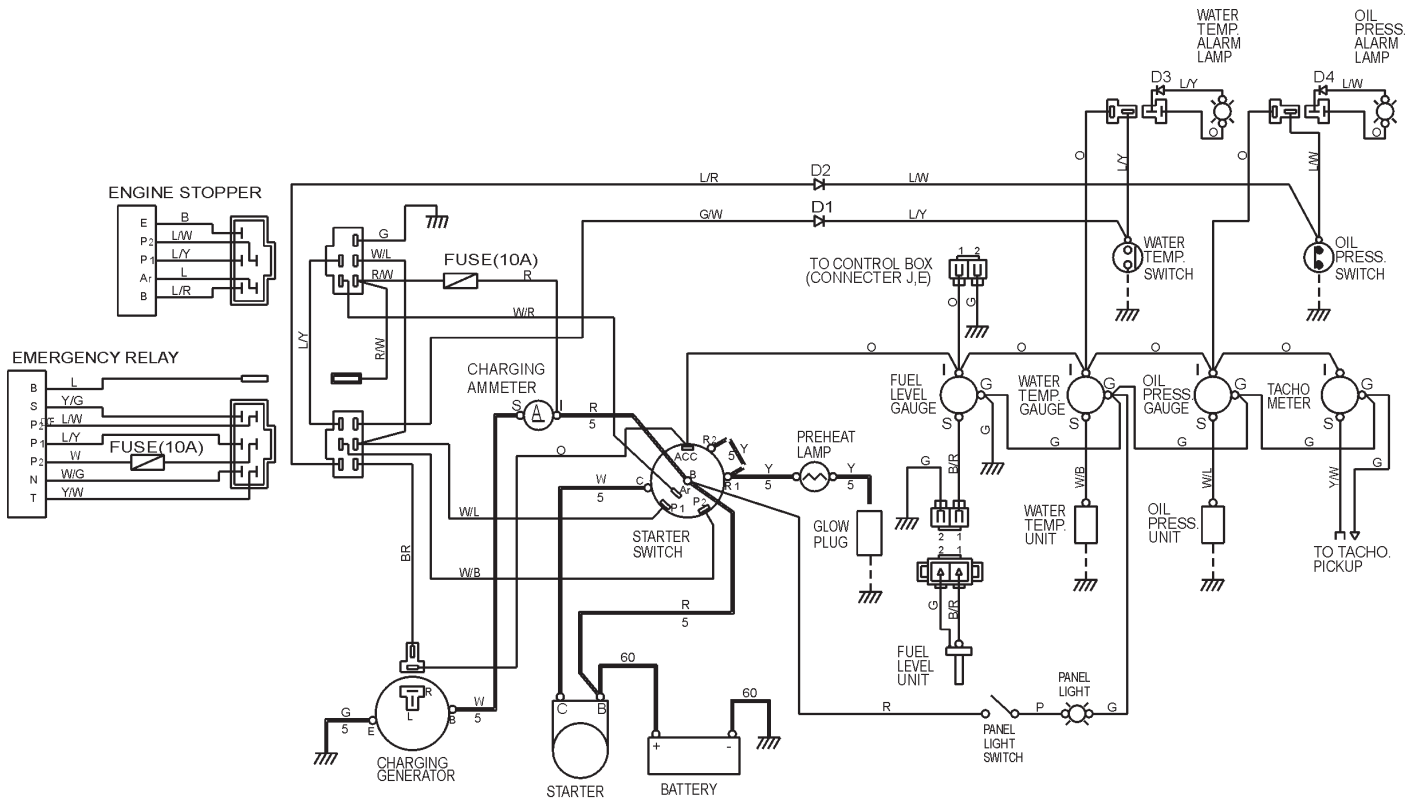

| | KEY CONNECTION DIAGRAM | | | | | | |
|---------|------------------------|-----|-----|-----|---|----|---------|
| | B | R 1 | ACC | R 2 | C | Ar | P 1 P 2 |
| OFF | ○ | | | | | | ○ ○ |
| PREHEAT | ○ ○ | | | | | | ○ ○ |
| RUN | ○ | ○ | | | | | ○ ○ |
| START | ○ | | ○ | ○ | | | ○ ○ |

CONNECTOR: view from inserting wire side

| WIRE SIZE | COLOR CODE | |
|--------------------------|------------|-----------------------|
| 60: 60 mm ² | WIRE COLOR | WIRE COLOR |
| 5: 5 mm ² | B BLACK | R RED |
| No. 1.25 mm ² | L BLUE | W WHITE |
| | BR BROWN | Y YELLOW |
| | G GREEN | LB LIGHT BLUE |
| | GR GRAY | LG LIGHT GREEN |
| | V VIOLET | O ORANGE |
| | P PINK | WIRE COLOR LINE COLOR |

DCA-25SSIU — TROUBLESHOOTING (ENGINE)

Practically all breakdowns can be prevented by proper handling and maintenance inspections, but in the event of a breakdown, use the tables shown for

diagnosis based on the Engine Troubleshooting (Table 14). If the problem cannot be remedied, consult our company's business office or service plant.

TABLE 14. ENGINE TROUBLESHOOTING

| SYMPTOM | POSSIBLE PROBLEM | SOLUTION |
|-----------------------------|--|---|
| Engine does not start. | No fuel? | Replenish fuel. |
| | Air in the fuel system? | Bleed system. |
| | Water in the fuel system? | Remove water from fuel tank. |
| | Fuel pipe clogged? | Clean fuel pipe. |
| | Fuel filter clogged? | Clean or change fuel filter. |
| | Excessively high viscosity of fuel or engine oil at low temperature? | Use the specified fuel or engine oil. |
| | Fuel with low cetane number? | Use the specified fuel. |
| | Fuel leak due to loose injection pipe retaining nut? | Tighten nut. |
| | Incorrect injection timing? | Adjust. |
| | Fuel cam shaft worn? | Replace. |
| | Injection nozzle clogged? | Clean injection nozzle. |
| | Injection pump malfunctioning? | Repair or replace. |
| | Seizure of crankshaft, camshaft, piston, cylinder liner or bearing? | Repair or replace. |
| | Compression leak from cylinder? | Replace head gasket, tighten cylinder head bolt, glow plug and nozzle holder. |
| | Improper valve timing? | Correct or replace timing gear. |
| Piston ring and liner worn? | Replace. | |
| Excessive valve clearance? | Adjust. | |
| Starter does not run. | Starter malfunctioning? | Repair or replace. |
| | Wiring disconnected? | Connect wiring. |

TABLE 14. ENGINE TROUBLESHOOTING (CONTINUED)

| SYMPTOM | POSSIBLE PROBLEM | SOLUTION |
|--|--|---|
| Engine revolution is not smooth. | Fuel filter clogged or dirty? | Clean or change. |
| | Air cleaner clogged? | Clean or change. |
| | Fuel leak due to loose injection pipe retaining nut? | Tighten nut. |
| | Injection pump malfunctioning? | Repair or replace. |
| | Incorrect nozzle opening pressure? | Adjust. |
| | Injection nozzle stuck or clogged? | Repair or replace. |
| | Fuel over flow pipe clogged? | Clean. |
| | Governor malfunctioning? | Repair. |
| Either white or blue exhaust gas is observed. | Excessive engine oil? | Reduce to the specified level. |
| | Piston ring and liner worn or stuck? | Repair or replace. |
| | Incorrect injection timing? | Adjust. |
| | Deficient compression? | Adjust top clearance. |
| Either black or dark gray exhaust gas is observed. | Overload? | Lessen the load. |
| | Low grade fuel used? | Use the specified fuel. |
| | Fuel filter clogged? | Clean or change. |
| | Air cleaner clogged? | Clean or change. |
| | Deficient nozzle injection? | Repair or replace the nozzle. |
| Deficient output. | Incorrect injection timing? | Adjust. |
| | Engine's moving parts seem to be seizing? | Repair or replace. |
| | Uneven fuel injection? | Repair or replace the injection pump. |
| | Deficient nozzle injection? | Repair or replace the nozzle. |
| | Compression leak? | Replace head gasket, tighten cylinder head bolt, glow plug and nozzle holder. |

DCA-25SSIU — TROUBLESHOOTING (GENERATOR/ENGINE)

Practically all breakdowns can be prevented by proper handling and maintenance inspections, but in the event of a breakdown, use the tables shown for diagnosis based on the Engine and Radiator Troubleshooting (Table15). If the problem cannot be remedied, consult our company's business office or service plant.

TABLE 15. GENERATOR TROUBLESHOOTING

| SYMPTOM | POSSIBLE PROBLEM | SOLUTION |
|-------------------------|-------------------------------|---|
| No Voltage Output | AC Voltmeter defective? | Check output voltage using a voltmeter. |
| | Is wiring connection loose? | Check wiring and repair. |
| | Is AVR defective? | Replace if necessary. |
| | Defective Rotating Rectifier? | Check and replace. |
| Low Voltage Output | Is engine speed correct? | Turn engine throttle lever to "High". |
| | Is wiring connections loose? | Check wiring and repair. |
| | Defective AVR? | Replace if necessary. |
| High Voltage Output | Is wiring connections loose? | Check wiring and repair. |
| | Defective AVR? | Replace if necessary. |
| Circuit Breaker Tripped | Short Circuit in load? | Check load and repair. |
| | Over current? | Confirm load requirements and reduce. |
| | Defective circuit breaker? | Check and replace. |
| | Over current Relay actuated? | Confirm load requirement and replace. |

EXPLANATION OF CODE IN REMARKS COLUMN

The following section explains the different symbols and remarks used in the Parts section of this manual. Use the help numbers found on the back page of the manual if there are any questions.

NOTICE

The contents and part numbers listed in the parts section are subject to change **without notice**. Multiquip does not guarantee the availability of the parts listed.

SAMPLE PARTS LIST

| NO. | PART NO. | PART NAME | QTY. | REMARKS |
|-----|----------|---------------------|------|---------------------|
| 1 | 12345 | BOLT..... | 1 | INCLUDES ITEMS W/% |
| 2% | | WASHER, 1/4 IN..... | | NOT SOLD SEPARATELY |
| 2% | 12347 | WASHER, 3/8 IN.... | 1 | MQ-45T ONLY |
| 3 | 12348 | HOSE | | A/R ...MAKE LOCALLY |
| 4 | 12349 | BEARING | 1 | S/N 2345B AND ABOVE |

NO. Column

Unique Symbols — All items with same unique symbol

(@, #, +, %, or >) in the number column belong to the same assembly or kit, which is indicated by a note in the “Remarks” column.

Duplicate Item Numbers — Duplicate numbers indicate multiple part numbers, which are in effect for the same general item, such as different size saw blade guards in use or a part that has been updated on newer versions of the same machine.

NOTICE

When ordering a part that has more than one item number listed, check the remarks column for help in determining the proper part to order.

PART NO. Column

Numbers Used — Part numbers can be indicated by a number, a blank entry, or TBD.

TBD (To Be Determined) is generally used to show a part that has not been assigned a formal part number at the time of publication.

A blank entry generally indicates that the item is not sold separately or is not sold by Multiquip. Other entries will be clarified in the “Remarks” Column.

QTY. Column

Numbers Used — Item quantity can be indicated by a number, a blank entry, or A/R.

A/R (As Required) is generally used for hoses or other parts that are sold in bulk and cut to length.

A blank entry generally indicates that the item is not sold separately. Other entries will be clarified in the “Remarks” Column.

REMARKS Column

Some of the most common notes found in the “Remarks” Column are listed below. Other additional notes needed to describe the item can also be shown.

Assembly/Kit — All items on the parts list with the same unique symbol will be included when this item is purchased.

Indicated by:

“INCLUDES ITEMS W/(unique symbol)”

Serial Number Break — Used to list an effective serial number range where a particular part is used.

Indicated by:

“S/N XXXXX AND BELOW”

“S/N XXXX AND ABOVE”

“S/N XXXX TO S/N XXX”

Specific Model Number Use — Indicates that the part is used only with the specific model number or model number variant listed. It can also be used to show a part is NOT used on a specific model or model number variant.

Indicated by:

“XXXXX ONLY”

“NOT USED ON XXXX”

“Make/Obtain Locally” — Indicates that the part can be purchased at any hardware shop or made out of available items. Examples include battery cables, shims, and certain washers and nuts.

“Not Sold Separately” — Indicates that an item cannot be purchased as a separate item and is either part of an assembly/kit that can be purchased, or is not available for sale through Multiquip.

DCA-25SSIU W/ISUZU C240 DIESEL ENGINE 1 TO 3 UNITS

| Qty. | P/N | Description |
|------|-------------|------------------------------|
| 10 | 0602046356 | CIRCUIT BREAKER |
| 20 | X132400150 | FUEL FILTER |
| 20 | 8970246071 | OIL FILTER |
| 5 | 5136710400 | FAN BELT |
| 1 | 8943768300 | WATER PUMP |
| 2 | 9136140430 | WATER PUMP GASKET |
| 2 | 1823100080 | STARTER SWITCH |
| 5 | KEYISUZUF | STARTER SWITCH KEY |
| 3 | 0602122272 | OIL SENDING UNIT |
| 2 | 5137700221 | THERMOSTAT |
| 2 | X137130020 | THERMOSTAT GASKET |
| 2 | 0602014504 | RADIATOR HOSE (UPPER) |
| 2 | 0602014601 | RADIATOR HOSE (LOWER) |
| 1 | 0605505070 | FUEL CAP |
| 8 | 9825119783 | GLOW PLUGS |
| 2 | 5153110060 | INJECTOR NOZZLES |
| 1 | 5825500422 | EMERGENCY RELAY |
| 1 | 5819000200 | STOPPER ENGINE |
| 1 | 5812003411 | ALTERNATOR |
| 1 | 8944532120 | STARTER |
| 1 | 0601820671 | AUTOMATIC VOLTAGE REGULATOR |
| 1 | 0601808810 | MAIN CIRCUIT BREAKER |
| 1 | 0601840073 | VOLTAGE REGULATOR (RHEOSTAT) |
| 1 | M1923100004 | SELECTOR SWITCH |
| 1 | 47130106 | SELECTOR SWITCH KNOB |
| 2 | 0601810245 | PREHEAT LAMP BULB |

NOTE

Part number on this Suggested Spare Parts list may supercede/replace the P/N shown in the text pages of this book.

DCA-25SSIU --- GENERATOR ASSY.

GENERATOR ASSY.

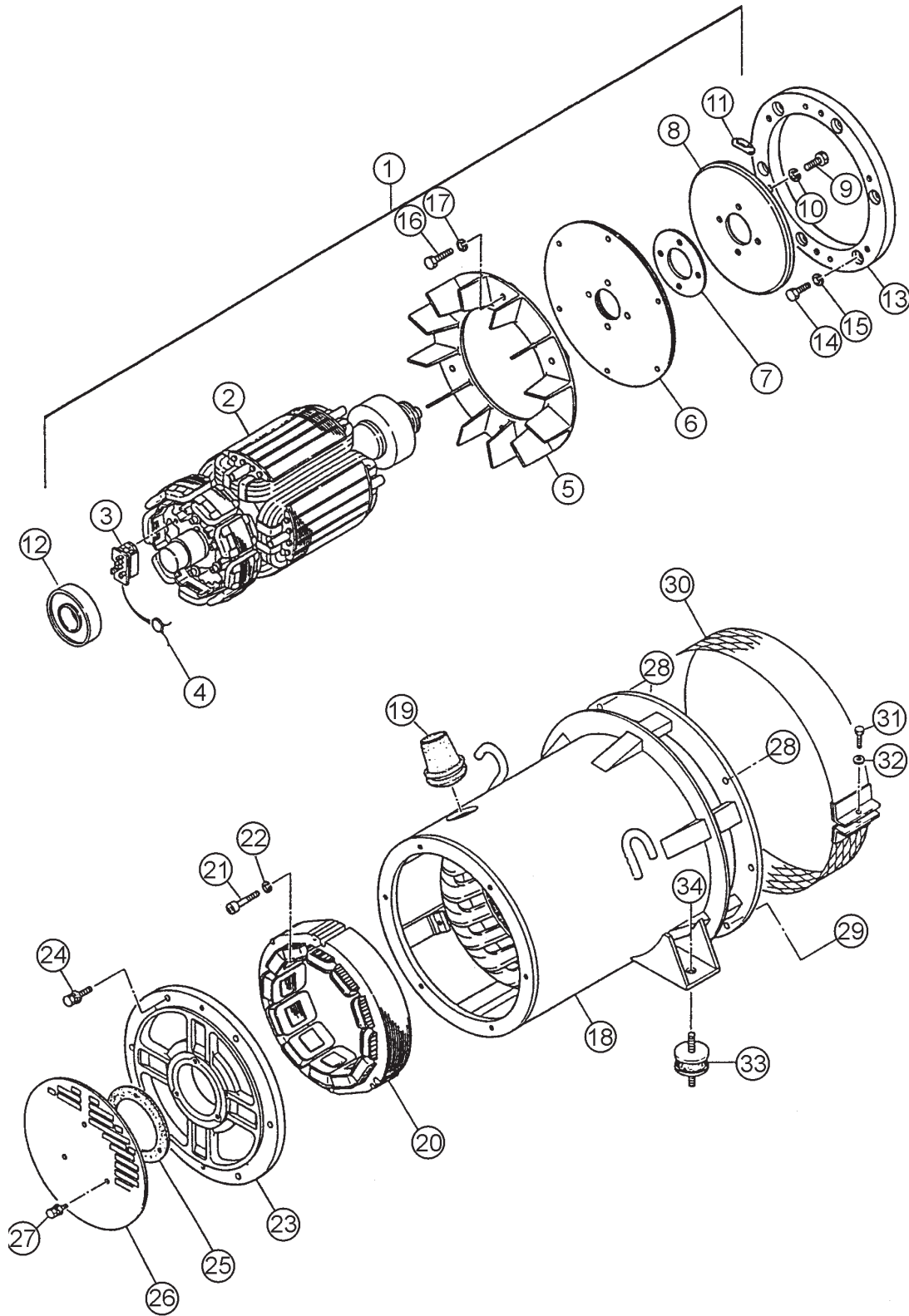

DCA-25SSIU --- GENERATOR ASSY.

GENERATOR ASSY.

| <u>NO.</u> | <u>PART NO.</u> | <u>ITEM</u> | <u>QTY.</u> | <u>REMARKS</u> |
|------------|-----------------|---------------------------|-------------|---|
| 1 | 8351000002 | ROTOR ASSY. | 1 | |
| 2 | | FIELD ASSY. | 1 | |
| 3 | 7961025004 | RECTIFIER | 1 | |
| 4 | 0601822630 | SURGE ABSORBER | 1 | TNR26G471K |
| 5 | 8001070003 | FAN | 1 | |
| 6 | 8351611004 | COUPLING DISK | 2 | |
| 7 | 8351612004 | WASHER, COUPLING HUB | 1 | |
| 8 | 8351615003 | BALANCING PLATE | 1 | |
| 9 | 0105091025 | HEX. HEAD BOLT | 4 | REPLACES 0010310025 |
| 10 | 0042610000 | LOCK WASHER | 4 | |
| 11 | 0601000209 | BALANCING WEIGHT KIT | 1 | |
| 12 | 042006308 | BEARING | 1 | 6308DDUC3; REPLACES 0071906308 |
| 13 | 8351614003 | COUPLING RING | 1 | REPLACES M1163400103 |
| 14 | 0012108025 | HEX. HEAD BOLT | 6 | |
| 15 | 0042508000 | LOCK WASHER | 6 | |
| 16 | 0012108035 | HEX. HEAD BOLT | 6 | |
| 17 | 0042508000 | LOCK WASHER | 6 | |
| 18 | B1130100203 | STRATOR ASSY. | 1 | |
| 19 | 0845041904 | GROMMET | 1 | |
| 20 | 8351350103A | FIELD ASSY. EXCITER | 1 | REPLACES 8351350103 |
| 21 | 0016008045 | HEX. SOCKET HAD CAP SCREW | 3 | |
| 22 | 0042508000 | LOCK WASHER | 3 | |
| 23 | 8351315003 | END BRACKET | 1 | |
| 24 | 011208035 | HEX. HEAD BOLT | 6 | REPLACES 0017108035 |
| 25 | 8351312004 | PACKING | 1 | |
| 26 | 8351331004 | COVER, SUCTION | 1 | |
| 27 | 0017106016 | HEX. HEAD BOLT | 3 | |
| 28 | 0105051045 | HEX. HEAD BOLT | 2 | S/N7100001 TO 7102574; REPLACES 0012110045 |
| | 0012310045 | HEX. HEAD BOLT | 2 | S/N7102575~ |
| | 0207010000 | HEX. NUT | 2 | |
| | 030210250 | LOCK WASHER | 2 | S/N7100001 TO 7102574; REPLACES 0042510000 |
| | 020310080 | HEX.NUT | 2 | REPLACES 0030010000 |
| 29 | 0012110040 | HEX. HEAD BOLT | 4 | S/N7100001 TO 7102574 |
| | 0012310040 | HEX. HEAD BOLT | 4 | S/N7102575~ |
| | 0207010000 | HEX. NUT | 4 | |
| | 030210250 | LOCK WASHER | 4 | S/N7100001 TO 7102574; REPLACES 0042510000 |
| 30 | 8351332004 | COVER, FAN | 1 | |
| 31 | 0010106030 | HEX.HEAD BOLT | 1 | |
| 32 | 952404470 | PLAIN WASHER | 1 | REPLACES 0041206000 |
| 33 | 0605000008 | RUBBER SUSPENSION | 2 | EA1009 |
| 34 | 0030012000 | HEX NUT | 2 | |
| | 0040012000 | LOCK WASHER | 2 | |
| | 031112230 | PLAIN WASHER | 2 | REPLACES 0041212000 |

DCA-25SSIU --- CONTROL BOX ASSY.

CONTROL BOX ASSY.

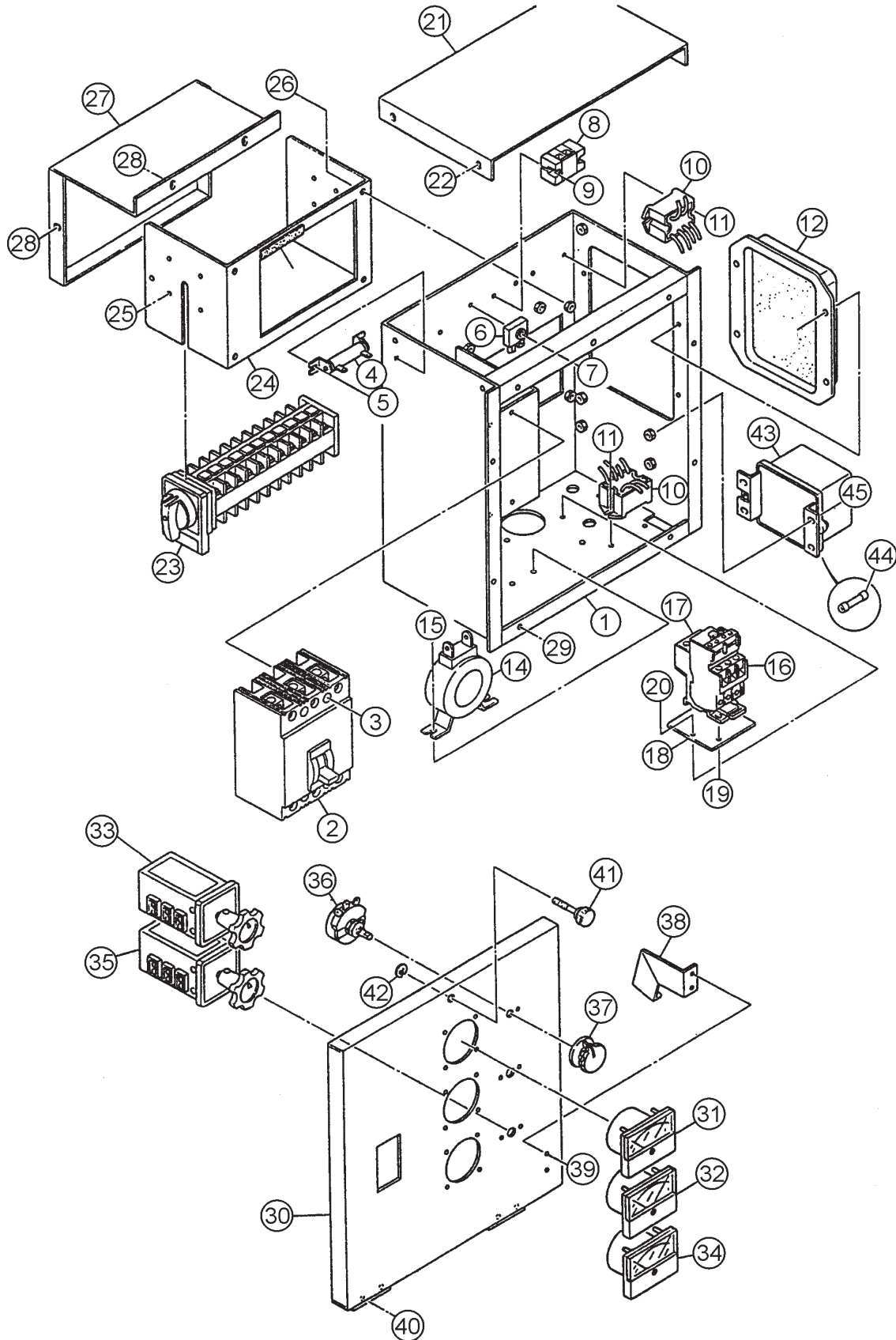

DCA-25SSIU --- CONTROL BOX ASSY.

CONTROL BOX ASSY.

| <u>NO.</u> | <u>PART NO.</u> | <u>ITEM</u> | <u>QTY.</u> | <u>REMARKS</u> |
|------------|-----------------|-----------------------------------|-------------|---|
| | M1246700514 | WIRE HARNESS, GENERATOR | 1 | UP TO S/N7106114 |
| | M1246700524 | WIRE HARNESS, GENERATOR | 1 | S/N7106115~ |
| 1 | M1213000202 | CONTROL BOX | 1 | S/N7100001 TO 7102144 |
| | M1213000212 | CONTROL BOX | 1 | S/N7102145 TO 7102314 |
| | M1213000222 | CONTROL BOX | 1 | S/N7102315~ |
| 2 | 0601808810 | CIRCUIT BREAKER | 1 | FAF340601021 3P 60A; UP TO S/N7106114 |
| | 0601808820 | CIRCUIT BREAKER | 1 | S/N7106115~ |
| 3 | 021005080 | MACHINE SCREW | 4 | |
| 4 | 0601842384 | RESISTOR | 1 | GG20W 50 OHM |
| 5 | 0027104010 | MACHINE SCREW | 2 | |
| 6 | 0601821370 | RECTIFIER | 3 | DE4503; REPLACES 0601823240 |
| 7 | 0021004040 | MACHINE SCREW | 1 | |
| | 0040004000 | LOCK WASHER | 1 | |
| | 031104080 | PLAIN WASHER | 1 | REPLACES 0041204000 |
| 8 | 0601815925 | TERMINAL BOARD | 1 | 202HB SP |
| 9 | 0027104020 | MACHINE SCREW | 2 | |
| 10 | 0601823863 | RELAY UNIT | 2 | MSA9013A |
| 11 | 0021304015 | MACHINE SCREW | 4 | REPLACES 0027104015 |
| 12 | 0601820671 | AUTOMATIC VOLTAGE REGULATOR | 1 | NTA5A2DB |
| 13 | 0027105010 | MACHINE SCREW | 4 | S/N7100001 TO 7102574 |
| | 0027105015 | MACHINE SCREW | 4 | S/N7102575~ |
| 14 | 0601806115 | CURRENT TRANSFORMER | 3 | 812943 50/5A |
| 15 | 011808015 | MACHINE SCREW | 6 | REPLACES 0027106015 |
| 16 | 0601820845 | OVER CURRENT RELAY | 1 | LR2D1308 |
| 17 | 0601820846 | OVER CURRENT RELAY | 1 | LR7D1064 |
| 18 | M1260600004 | FITTING BRACKET | 1 | S/N7100001 TO 7102314 |
| 19 | 0021304015 | MACHINE SCREW | 2 | S/N7100001 TO 7102314; REPLACES 0027104015 |
| | 0030004000 | HEX. NUT | 2 | REPLACES 0207004000 |
| 20 | 0027104010 | MACHINE SCREW | 2 | |
| 21 | M1213500203 | CONTROL BOX COVER | 1 | |
| 22 | 011106015 | HEX. HEAD BOLT | 4 | REPLACES 0016906015 |
| 23 | M1923100004 | SELECTOR SWITCH | 1 | VY40 |
| 24 | M1213600104 | SWITCH BRACKET | 1 | S/N7100001 TO 7102144 |

ADD THE FOLLOWING DIGITS AFTER THE PART NUMBER
WHEN ORDERING ANY PAINTED PANEL TO INDICATE

COLOR OF UNIT:

| | |
|-----------------|----------------------|
| 1-ORANGE | 5-BLACK |
| 2-WHITE | 6-CATERPILLAR YELLOW |
| 3-SPECTRUM GRAY | 7-CATO GOLD |
| 4-SUNBELT GREEN | 8-RED |

THE SERIAL NUMBER MAY BE REQUIRED.

DCA-25SSIU --- CONTROL BOX ASSY.

CONTROL BOX ASSY.

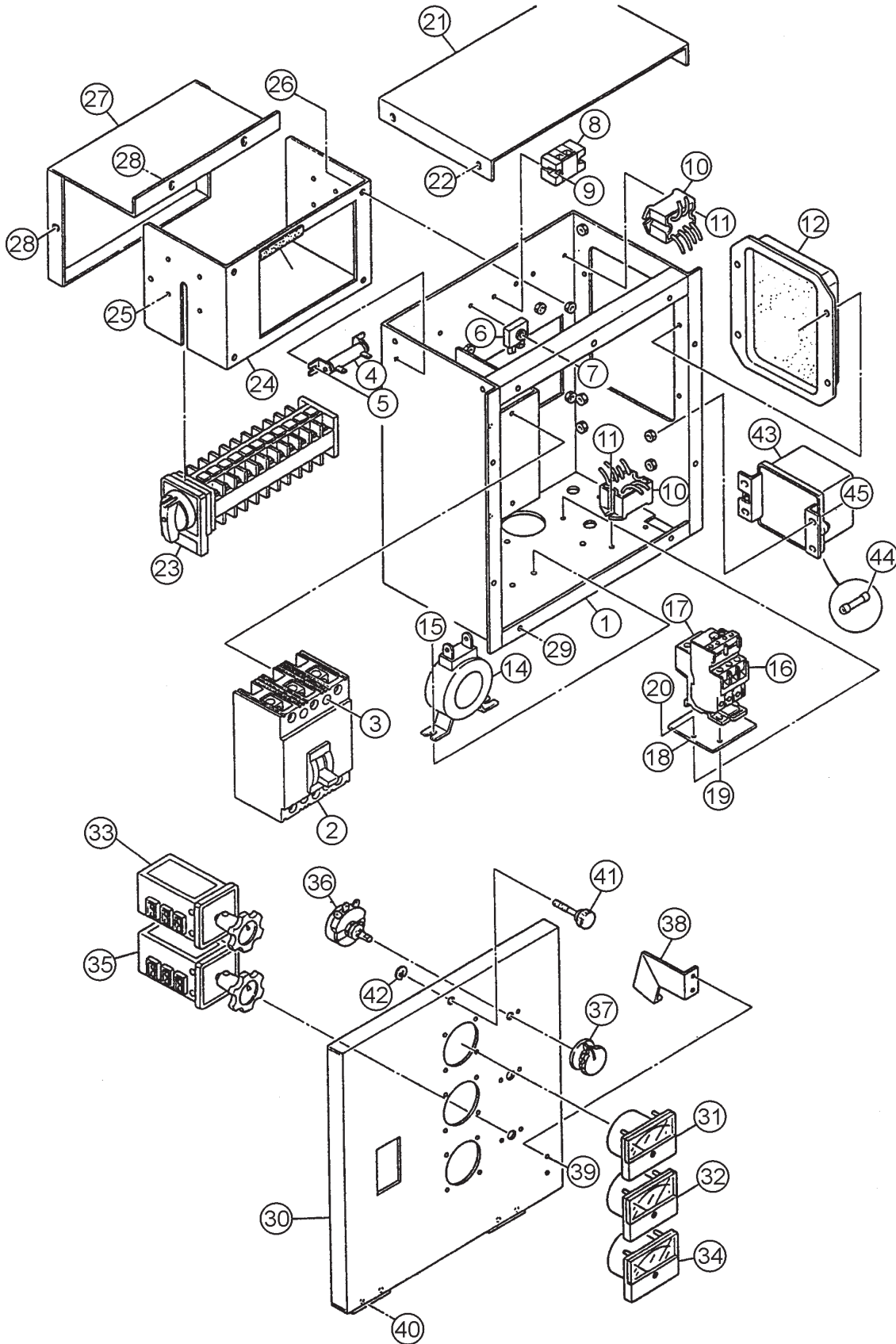

DCA-25SSIU --- CONTROL BOX ASSY.

CONTROL BOX ASSY.

| <u>NO.</u> | <u>PART NO.</u> | <u>ITEM</u> | <u>QTY.</u> | <u>REMARKS</u> |
|------------|-----------------|--|-------------|---|
| | M1213600114 | SWITCH BRACKET | 1 | S/N7102145 |
| 25 | 0027103010 | MACHINE SCREW | 4 | |
| 26 | 011106015 | HEX. HEAD BOLT | 4 | REPLACES 0016906015 |
| 27 | M1213600004 | SWITCH COVER | 1 | S/N7100001 TO 7102144 |
| | M1213600014 | SWITCH COVER | 1 | S/N7102145~ |
| 28 | 011106015 | HEX. HEAD BOLT | 4 | S/N7100001 TO 7102059; REPLACES 0016906015 |
| | 011106015 | HEX. HEAD BOLT | 3 | S/N7102059~; REPLACES 0016906015 |
| 29 | 0016906015 | HEX. HEAD BOLT | 8 | |
| | 0040506000 | TOOTHED WASHER | 1 | |
| 30 | M1223000203 | CONTROL PANEL | 1 | |
| 31 | 0601807630 | FREQUENCY METER,264250DJDJ9; | 1 | REPLACES 0601807696 UP TO S/N7105234 |
| | 0601807641 | FREQUENCY METER, FCF6 45-65HZ 240V ... | 1 | FROM S/N7105235~ |
| 32 | 0601808952 | AC AMMETER,260240LSNT1 | 1 | REPLACES 0601808991; UP TO S/N7105234 |
| 32 | 0601808985 | AC AMMETER, ACF60-50A,0-100A/5A | 1 | FROM S/N7105235~ |
| 33 | 0601801040 | CHANGE-OVER SWITCH, AMMETER | 1 | SL2AS |
| 34 | 0601806813 | AC VOLTMETER,260244SJSJ1; | 1 | REPLACES 0601806896 UP TO S/N7105234 |
| | 0601806859 | AC VOLTMETER, SCF6 0-600V | 1 | FROM S/N7105235~ |
| 35 | 0601801041 | CHANGE-OVER SWITCH VOLTMETER | 1 | SL2VS |
| 36 | 0601840073 | RHEOSTAT (VOLTAGE REGULATOR) | 1 | RA20A2SE102BJ 2W 1K OHM |
| 37 | 0601840121 | KNOB | 1 | |
| 38 | M122310004 | STOPPER | 1 | |
| 39 | 0027105015 | MACHINE SCREW | 2 | S/N7100001 TO 7102674 |
| | 0027105010 | MACHINE SCREW | 2 | S/N7102675~ |
| 40 | 0027105015 | MACHINE SCREW | 4 | S/N7100001 TO 7102674 |
| | 0027105010 | MACHINE SCREW | 4 | S/N7102675~ |
| 41 | M9220100004 | SET SCREW | 1 | |
| 42 | 0080200007 | SNAP RING | 1 | |
| 43 | 5825500422 | EMERGENCY RELAY | 1 | REPLACES 0602200400 |
| 44 | 06018020132 | FUSE | 1 | |
| 45 | 011106015 | HEX. HEAD BOLT | 4 | REPLACES 0016906015 |
| 46 | 0330000160 | EDGING | 2 | S/N7100131~ |

ADD THE FOLLOWING DIGITS AFTER THE PART NUMBER
WHEN ORDERING ANY PAINTED PANEL TO INDICATE
COLOR OF UNIT:

| | |
|-----------------|----------------------|
| 1-ORANGE | 5-BLACK |
| 2-WHITE | 6-CATERPILLAR YELLOW |
| 3-SPECTRUM GRAY | 7-CATO GOLD |
| 4-SUNBELT GREEN | 8-RED |

THE SERIAL NUMBER MAY BE REQUIRED.

DCA-25SSIU ENGINE AND RADIATOR ASSY.

ENGINE AND RADIATOR ASSY.

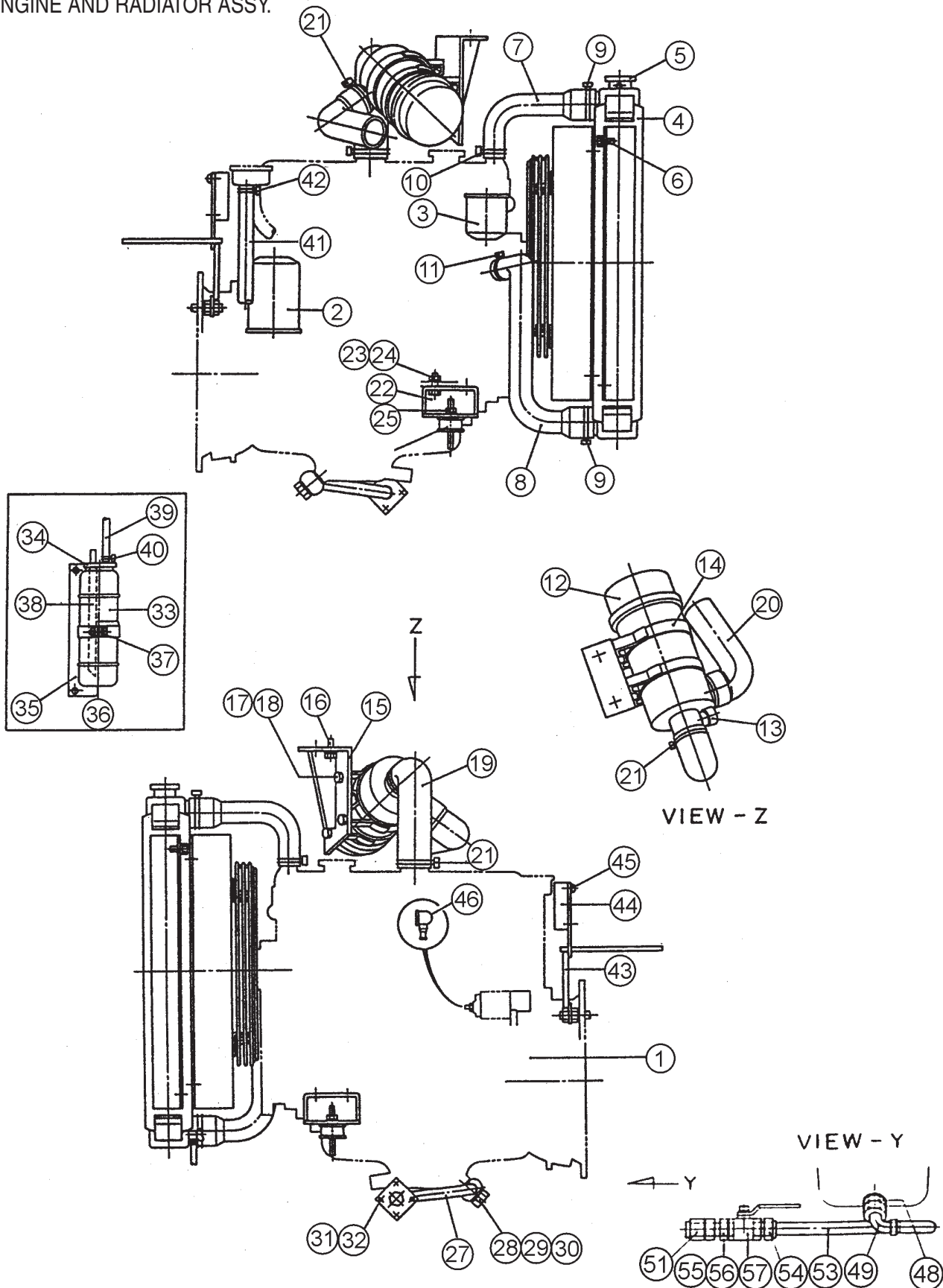

DCA-25SSIU ENGINE AND RADIATOR ASSY.

ENGINE AND RADIATOR ASSY.

| <u>NO.</u> | <u>PART NO.</u> | <u>ITEM</u> | <u>QTY.</u> | <u>REMARKS</u> |
|------------|-----------------|------------------------------|-------------|--|
| 1 | M1923200004A | ENGINE | 1 | ISUZU QD60(C240) S/N7100001 TO 7102685 |
| | M1925200004 | ENGINE | 1 | ISUZU QD60(C240) S/N7102686~ |
| | 5136710400 | FAN BELT | 1 | REPLACES 0602011401 |
| 2 | 8970246071 | CARTRIDGE, OIL FILTER | 1 | REPLACES 0602041212 |
| 3 | X132400150 | CARTRIDGE, FUEL FILTER | 1 | REPLACES 0602042510 |
| 4 | 0602011996 | RADIATOR | 1 | C2810010000 |
| 5 | 0602011065 | CAP | 1 | C89C0115010 |
| 6 | 011008020 | HEX. HEAD BOLT | 6 | REPLACES 0016908020 |
| 7 | 0602014504 | RADIATOR HOSE, UPER | 1 | S/N7100001 TO 7101005 |
| | M1310500103 | RADIATOR HOSE, UPPER | 1 | S/N7101006~ |
| 8 | 06020146010 | RADIATOR HOSE, LOWER | 1 | S/N7100001 TO 7101005 |
| | M1310500203 | RADIATOR HOSE, LOWER | 1 | S/N7101006~ |
| 9 | 0602014334 | HOSE BAND | 2 | S/N7100001 TO 7100050 |
| | 0605515147 | HOSE BAND | 2 | S/N7100051~ |
| 10 | 0602014332 | HOSE BAND | 1 | S/N7100001 TO 7100050 |
| | 0605515149 | HOSE BAND | 1 | S/N7100051~ |
| 11 | 0602014333 | HOSE BAND | 1 | S/N7100001 TO 7100050 |
| | 0605515149 | HOSE BAND | 1 | S/N710051~ |
| 12 | 0602046231 | AIR CLEANER | 1 | S/N7100001 TO S/N7104749 |
| | 0602046580 | AIR CLEANER | 1 | S/N7104750~ |
| | 0602046356 | ELEMENT, AIR CLEANER | 1 | S/N7100001 TO S/N7104749; |
| | 0602046321 | ELEMENT, AIR CLEANER | 1 | S/N7104750~ |
| 13 | 0602040650 | INDICATOR, AIR CLEANER | 1 | S/N7100001 TO S/N7104749 |
| | 0602040651 | INDICATOR, AIR CLEANER | 1 | S/N7104750~ |
| 14 | 0602040593 | BAND, AIR CLEANER | 2 | S/N7100001 TO 7104749 |
| | 0602040552 | BAND, AIR CLEANER | 1 | S/N7104750~ |
| 15 | M1373200003 | BRACKET, AIR CLEANER | 1 | S/N7100001 TO S/N7104749 |
| 16 | 012210025 | HEX. HEAD BOLT | 2 | S/N7100001 TO S/N7104749; |
| | | | | REPLACES 0016910025 |
| 17 | 011008020 | HEX. HEAD BOLT | 4 | S/N7100001 TO 7100050; |
| | | | | REPLACES 0016908020 |
| 18 | 0013003008 | HEX. HEAD BOLT | 4 | S/N7100051 TO S/N7104749 |
| | 0016908030 | HEX. HEAD BOLT | 2 | S/N7104750~ |
| 19 | 020108060 | HEX. NUT | 4 | S/N7100001 TO 7100050; |
| | | | | REPLACES 0207008000 |
| | 0036203000 | HEX.NUT | 4 | S/N7100051 TO S/N7104749 |
| | 020108060 | HEX.NUT | 2 | S/N7104750~; REPLACES 0207008000 |
| | 0043003000 | LOCK WASHER | 4 | S/N710051 TO S/N7104749 |
| | 0043103000 | PLAIN WASHER | 4 | S/N7100051 TO S/N7104749 |
| | 8352032303 | HOSE, AIR CLEANER | 1 | REPLACES M1373100103 |
| 20 | M137310004 | HOSE, AIR CLEANER | 1 | |
| 21 | 0605515010 | HOSE BAND | 3 | S/N7100001 TO S/N7100050 |
| | 060551547 | HOSE BAND | 3 | S/N7100051~ |
| 22 | M1303200004 | ENGINE FOOT | 2 | |

DCA-25SSIU ENGINE AND RADIATOR ASSY.

ENGINE AND RADIATOR ASSY.

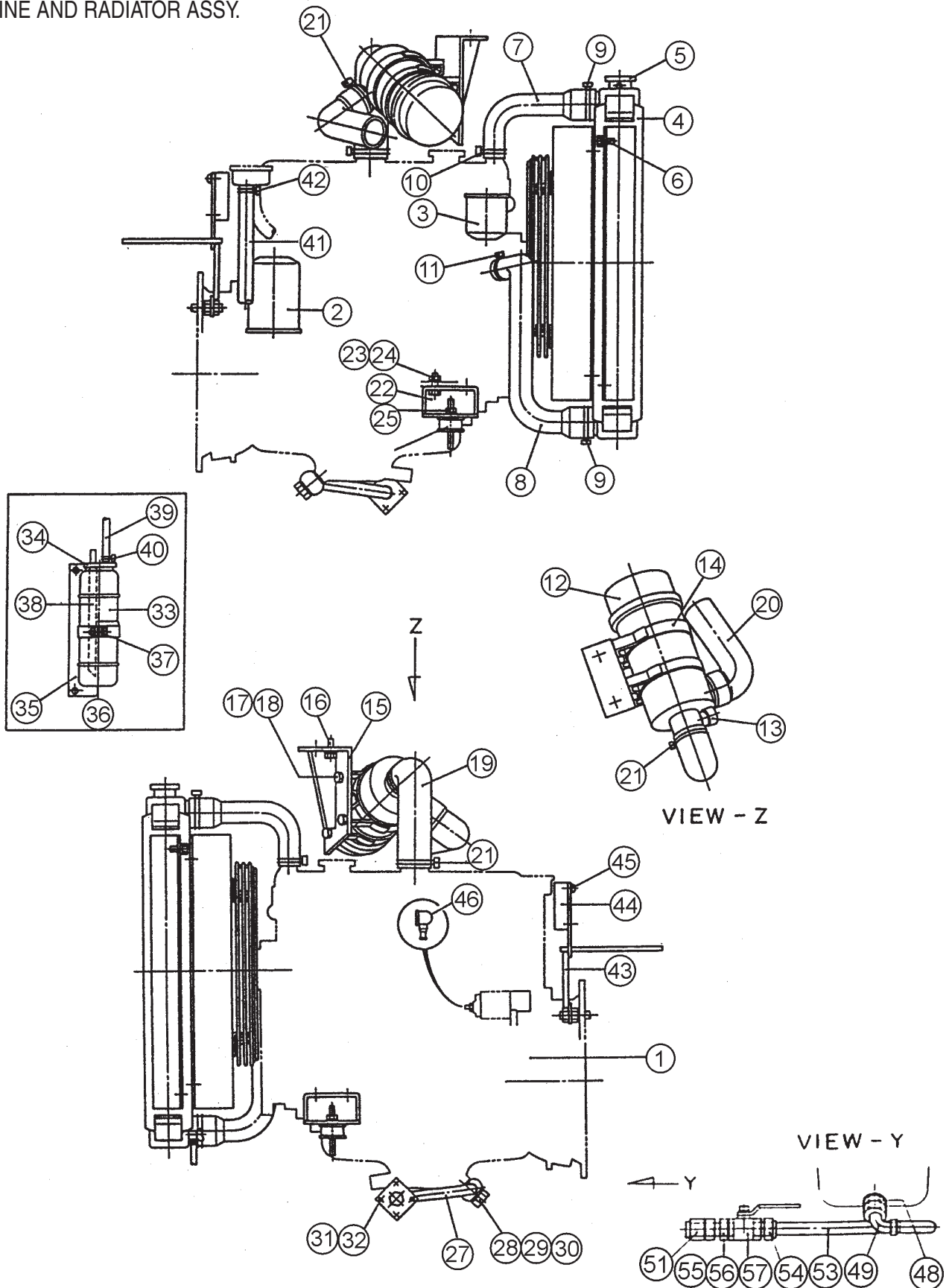

DCA-25SSIU ENGINE AND RADIATOR ASSY.

ENGINE AND RADIATOR ASSY.

| <u>NO.</u> | <u>PART NO.</u> | <u>ITEM</u> | <u>QTY.</u> | <u>REMARKS</u> |
|------------|-----------------|-----------------------------|-------------|---|
| 23 | 012010030 | HEX. HEAD BOLT | 4 | REPLACES 0017110030 |
| 24 | 0207010000 | HEX. NUT | 4 | |
| 25 | 060500006 | RUBBER SUSPENSION | 2 | EA1007 |
| 26 | 020701000 | HEX. NUT | 2 | |
| 27 | M1320200003 | DRAIN PIPE | 1 | S/N7100001 TO S/N7100130 |
| 28 | M1320300204 | PACKING, OIL PAN SIDE | 1 | S/N7100001 TO S/N7100130; REPLACES M1320300204 |
| 29 | 9095720240 | PACKING | 1 | S/N7100001 TO S/N7100130; REPLACES 0602021107 |
| 30 | M1320300104 | JOINT BOLT | 1 | S/N7100001 TO S/N7100130 |
| 31 | 011206020 | HEX. HEAD BOLT | 2 | S/N7100001 TO S/N7100130; REPLACES 0016906020 |
| 32 | 0207006000 | HEX. NUT | 2 | S/N7100001 TO S/N7100130 |
| 33 | M9300000003 | RESERVE TANK | 1 | |
| 34 | M9300100003 | CAP, RESERVE TANK | 1 | |
| 35 | M1316100204 | BRACKET, RESERVE TANK | 1 | |
| 36 | 0229200300 | RUBBER CUSHION | 1 | S/N7100001 TO S/N7100150 |
| 37 | 011206020 | HEX. HEAD BOLT | 1 | S/N7100001 TO S/N7100150; REPLACES 0016906020 |
| 38 | 0199100215 | HOSE | 1 | |
| 39 | 0193601450 | HOSE | 1 | |
| 40 | 0605515106 | HOSE BAND | 1 | S/N7100001 TO S/N7100150 |
| 41 | 0194500600 | HOSE | 1 | S/N7100001 TO S/N7100150 |
| 42 | 0605515003 | HOSE BAND | 2 | S/N7100001 TO S/N7100150 |
| 43 | M1483600503 | CLAMP BAR | 1 | REPLACES M1483600103 |
| 44 | 5819000200 | ENGINE STOPPER | 1 | REPLACES 06022108020 |
| | 06018020132 | FUSE | 1 | |
| 45 | 011808015 | MACHINE SCREW | 3 | REPLACES 0027106015 |
| 46 | 0602220621 | TERMINAL COVER | 1 | S/N7100001 TO S/N7100150 |
| 47 | 0602022560 | ADAPTER | 1 | S/N7100131~ |
| 48 | M1320300304 | PACKING | 1 | S/N7100131~ |
| 49 | 0602025561 | 90° ELBOW | 1 | S/N7100131~ |
| 50 | 0602022562 | UNION | 1 | S/N7100131 TO S/N7104749 |
| 51 | 0602022792 | SWIVEL | 1 | S/N 7100131 TO S/N7104749 |
| 52 | 0602021070 | CAP | 1 | S/N 7100131~ |
| 53 | 0602021570 | DRAIN HOSE | 1 | S/N 7100131 TO S/N7104749 |
| | 0269200660 | DRAIN HOSE | 1 | S/N7104750~ |
| 54 | 0603306395 | HOSE JOINT | 1 | S/N7104750~ |
| 55 | 0603306590 | CONNECTOR | 1 | S/N7104750~ |
| 56 | 0603300285 | ROCK NUT | 1 | S/N7104750~ |
| 57 | 0605511395 | VALVE | 1 | S/N7104750~ |

DCA-25SSIU --- ENGINE OPERATING PANEL ASSY.

ENGINE OPERATING PANEL ASSY.

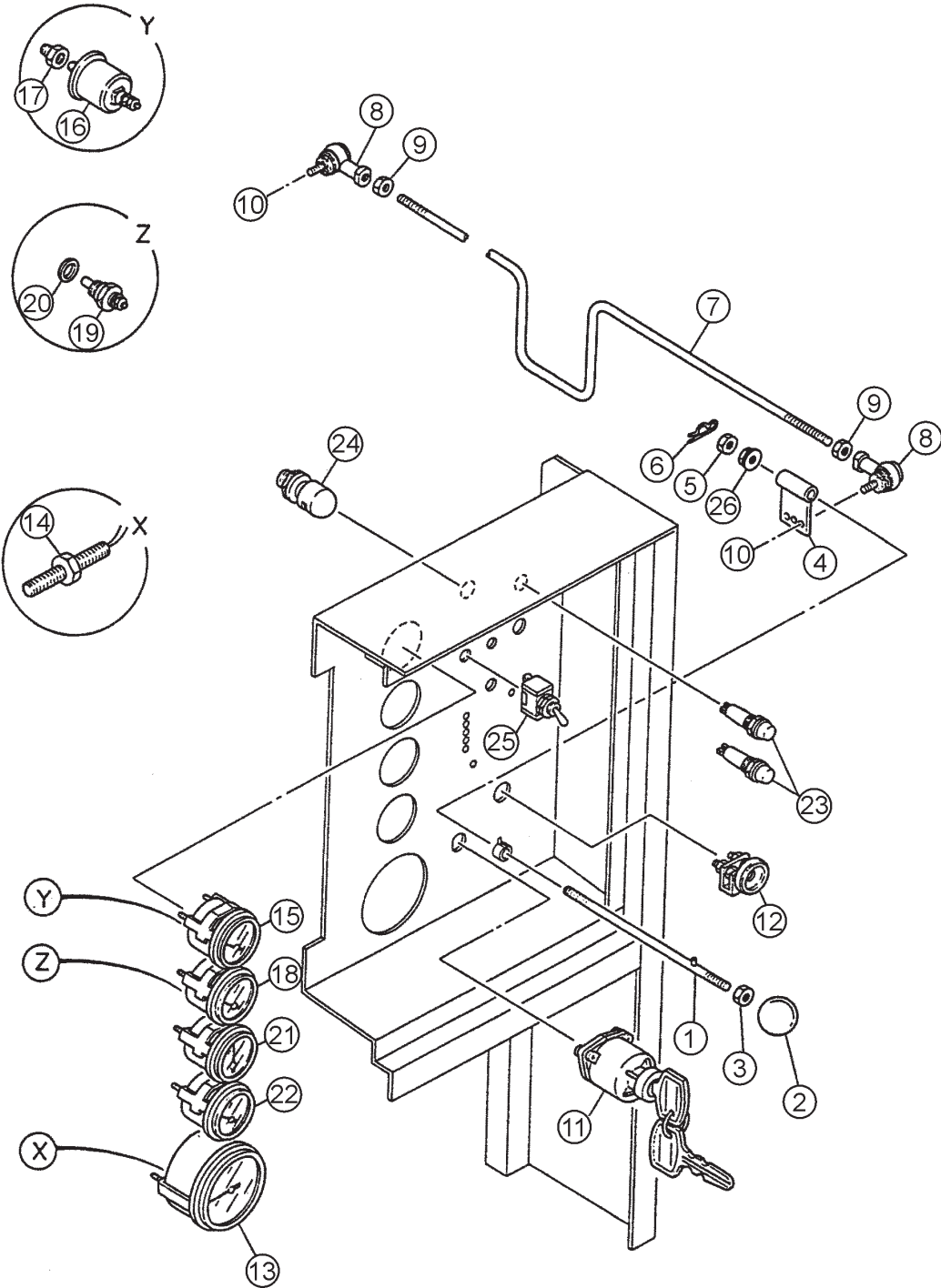

DCA-25SSIU --- ENGINE OPERATING PANEL ASSY.

ENGINE OPERATING PANEL ASSY.

| NO. | PART NO. | ITEM | QTY. | REMARKS |
|-----|--------------|-------------------------------|------|--|
| | M1357200102A | WIRE HARNESS, ENGINE | 1 | |
| 1 | M1354300304 | SLIDE LEVER | 1 | |
| 2 | 0601840190 | KNOB | 1 | REPLACES M9320000004 |
| 3 | 020108060 | HEX. NUT | 1 | REPLACES 0036003000 |
| 4 | M1354200004 | BRACKET | 1 | ASK CUST. SVC. FOR COLOR |
| 5 | 020108060 | HEX. NUT | 1 | REPLACES 0030008000 |
| 6 | 0605010503 | SNAP PIN | 1 | |
| 7 | M1354300204 | GOVERNOR ROD | 1 | |
| 8 | 0602180106 | BALL JOINT | 2 | LHSA8DE161 |
| 9 | 020108060 | HEX. NUT | 2 | REPLACES 0030008000 |
| 10 | 0207006000 | HEX. NUT | 2 | |
| | 0041206000 | PLAIN WASHER | 2 | |
| 11 | 1823100080 | STARTER SWITCH | 1 | REPLACES 0602100004 |
| 12 | 8944626110 | PREHEAT LAMP | 1 | REPLACES 0602102066 |
| 13 | 0602120095 | TACHOMETER | 1 | 103680 |
| 14 | 0602120480 | PICK UP, TACHOMETER | 1 | 7154400 |
| 15 | 0602122093 | OIL PRESSURE GAUGE | 1 | 100174 |
| 16 | 0602122272 | OIL PRESSURE UNIT | 1 | 102225; S/N7100001 TO S/N7101239; REPLACES 0602122207 |
| 17 | M9200100004 | ADAPTER | 1 | |
| 18 | 0602123090 | WATER TEMPERATURE GAUGE | 1 | 100683 |
| 19 | 0602123201 | WATER TEMPERATURE UNIT | 1 | 0209400 |
| 20 | 9095720140 | PACKING | 1 | REPLACES 0602121109 |
| 21 | 0602121080 | CHARGING AMMETER | 1 | 100158 |
| 22 | 0602128090 | FUEL GAUGE | 1 | 100176 |
| 23 | 0602103092 | ALARM LAMP | 2 | PL05 |
| | 0601810245 | BULB | 2 | E10T10 DC18V |
| 24 | 0601810141 | PANEL LIGHT | 1 | ISUZU 9826800370 |
| 25 | 0601831330 | SWITCH, PANEL LIGHT | 1 | 900001 |
| 26 | 020108060 | HEX. NUT | 1 | REPLACES 0207008000 |

ADD THE FOLLOWING DIGITS AFTER THE PART NUMBER
WHEN ORDERING ANY PAINTED PANEL TO INDICATE
COLOR OF UNIT:

| | |
|-----------------|----------------------|
| 1-ORANGE | 5-BLACK |
| 2-WHITE | 6-CATERPILLAR YELLOW |
| 3-SPECTRUM GRAY | 7-CATO GOLD |
| 4-SUNBELT GREEN | 8-RED |

THE SERIAL NUMBER MAY BE REQUIRED.

DCA-25SSIU --- OUTPUT TERMINAL ASSY.

OUTPUT TERMINAL ASSY.

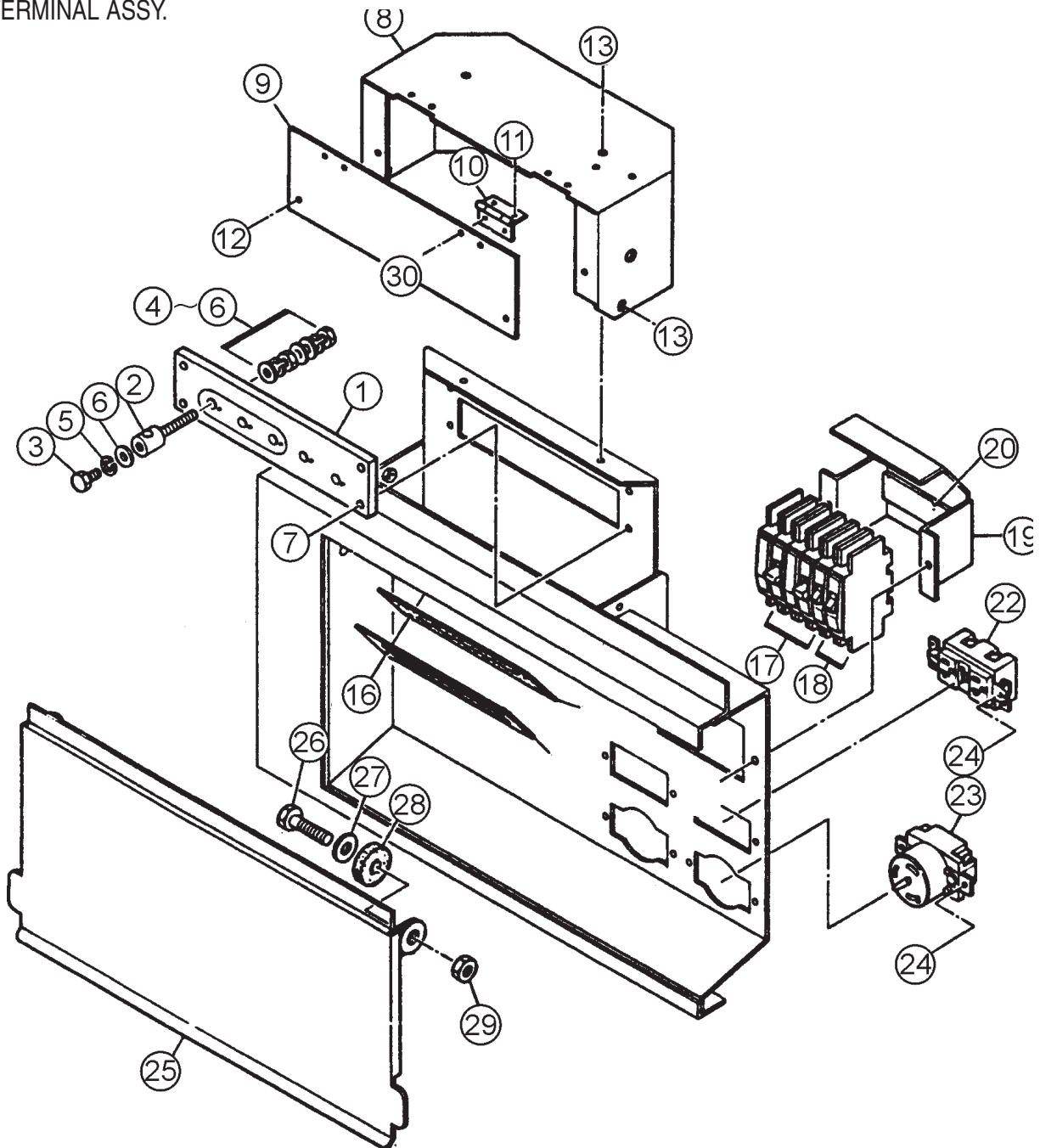

ADD THE FOLLOWING DIGITS AFTER THE PART NUMBER
WHEN ORDERING ANY PAINTED PANEL TO INDICATE
COLOR OF UNIT:

| | |
|-----------------|----------------------|
| 1-ORANGE | 5-BLACK |
| 2-WHITE | 6-CATERPILLAR YELLOW |
| 3-SPECTRUM GRAY | 7-CATO GOLD |
| 4-SUNBELT GREEN | 8-RED |

THE SERIAL NUMBER MAY BE REQUIRED.

DCA-25SSIU --- OUTPUT TERMINAL ASSY.

OUTPUT TERMINAL ASSY.

| <u>NO.</u> | <u>PART NO.</u> | <u>ITEM</u> | <u>QTY</u> | <u>REMARKS</u> |
|------------|-----------------|-------------------------------|------------|--|
| 1 | 8091860103 | TERMINAL PANEL | 1 | REPLACES M1230700003 |
| 2 | 0801830104A | OUTPUT TERMINAL BOLT | 5 | REPLACES M922000004 |
| 3 | 0801832204 | TIE BOLT | 5 | REPLACES M9220000104 |
| 4 | 0039308000 | HEX. NUT | 10 | |
| 5 | 0040008000 | LOCK WASHER | 15 | |
| 6 | 0041408000 | PLAIN WASHER | 20 | |
| 7 | 011606025 | HEX. HEAD BOLT | 4 | S/N7100001 TO S/N7102674; REPLACES 0016906025 |
| | 011206020 | HEX. HEAD BOLT | 4 | S/N7102675~ |
| 8 | M1236100303 | TERMINAL COVER | 1 | S/N7100001 TO S/N7102784 |
| | M1236100313 | TERMINAL COVER | 1 | S/N7102785~ |
| 9 | M1236100404 | OUTPUT WINDOW | 1 | |
| 10 | 0605010040 | HINGE | 2 | |
| 11 | 0027103010 | MACHINE SCREW | 4 | |
| | 0207003000 | HEX.NUT | 4 | REPLACES 0030003000 |
| | 58413 | PLAIN WASHER | 4 | REPLACES 0041203000 |
| 12 | 011206020 | HEX. HEAD BOLT | 2 | REPLACES 0016906020 |
| 13 | 011106015 | HEX. HEAD BOLT | 4 | REPLACES 0016906015 |
| 14 | M1236400004 | CABLE OUTLET COVER | 1 | |
| 15 | M1236300004 | SUPPORTER, CABLE OUTLET COVER | 1 | |
| 16 | 011206020 | HEX. HEAD BOLT | 6 | REPLACES 0016906020 |
| 17 | 0601808804 | CIRCUIT BREAKER | 2 | QOU250B 2P 50A |
| 18 | 06018088030 | CIRCUIT BREAKER | 2 | QOU120B 1P 50A |
| 19 | M1260700204 | BREAKER FITTING COVER | 1 | |
| 20 | 0222100115 | CUSHION RUBBER | 1 | |
| 21 | 011206020 | HEX. HEAD BOLT | 2 | REPLACES 0016906020 |
| 22 | 0601812597 | RECEPTACLE | 2 | GF530EM125V 20AX2 REPLACES 0601812549 |
| 23 | 0601811034 | RECEPTACLE | 2 | CA6369 250V 50A ; REPLACES 0601812538 |
| 24 | 0021304015 | MACHINE SCREW | 8 | REPLACES 0027104015 |
| | 0030004000 | HEX. NUT | 8 | REPLACES 0207004000 |
| 25 | M1236100503 | TERMINAL COVER | 1 | |
| 26 | 012212045 | HEX.HEAD BOLT | 2 | REPLACES 0010112045 |
| 27 | 031112230 | PLAIN WASHER | 2 | REPLACES 0041212000 |
| 28 | M9310200004 | STAY RUBBER | 2 | |
| 29 | 0030012000 | HEX. NUT | 2 | |
| 30 | 0027103010 | MACHINE SCREW | 4 | |
| | 0207003000 | HEX. NUT | 4 | REPLACES 0030003000 |

DCA-25SSIU --- BATTERY ASSY.

BATTERY ASSY.

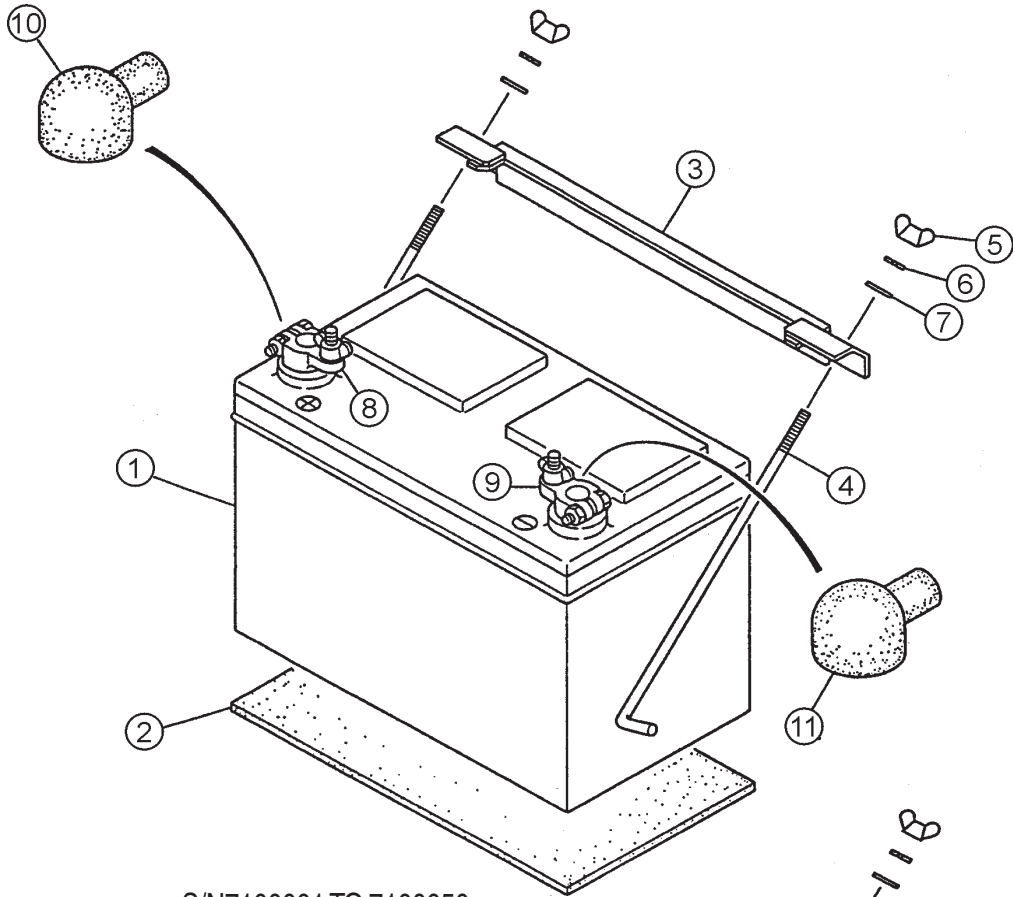

S/N710001 TO 7100050

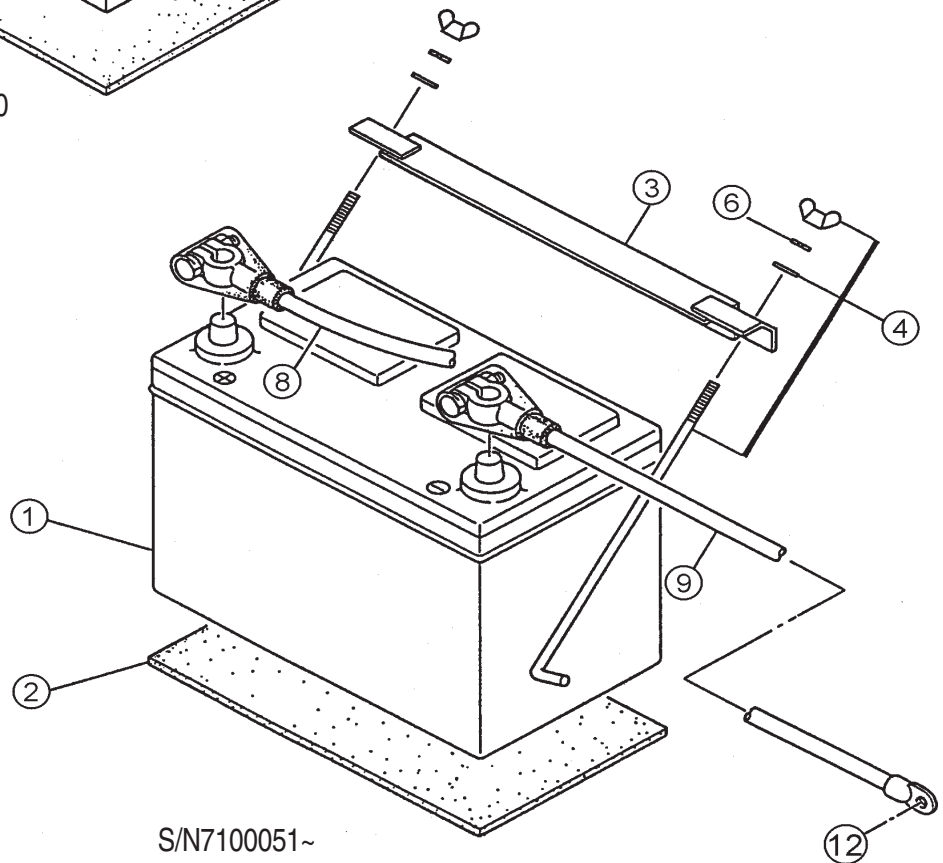

S/N7100051~

BATTERY ASSY.

| <u>NO.</u> | <u>PART NO.</u> | <u>ITEM</u> | <u>QTY.</u> | <u>REMARKS</u> |
|------------|-----------------|------------------------|-------------|---|
| 1 | 0602220185 | BATTERY | 1 | 427MF |
| 2 | M9310500014 | BATTERY SHEET | 1 | |
| 3 | M9103000304 | BATTERY BAND | 1 | |
| 4 | M0602220920 | BATTERY BOLT SET | 2 | BHL10J;REPLACES M9103200004 |
| 5 | 0037808000 | WING NUT | 2 | S/N7100001 TO S/N7100050 |
| 6 | 0040008000 | LOCK WASHER | 2 | S/N7100001 TO S/N7100050 |
| | 0040006000 | LOCK WASHER | 2 | S/N7100051~ |
| 7 | 031108160 | PLAIN WASHER | 2 | S/N7100001 TO S/N7100050; REPLACES 0041208000 |
| 8 | 0602220310 | TERMINAL ASSY. | 1 | NO.9P S/N7100001 TO S/N7100050 |
| | M134640004 | BATTERY CABLE | 1 | S/N7100051~ |
| 9 | 0602220311 | TERMINAL ASSY. | 1 | NO.9P S/N7100001 TO S/N7100050 |
| | M1346400104 | BATTERY CABLE | 1 | S/N7100051 TO S/N7101005 |
| | M2346400104 | BATTERY CABLE | 1 | S/N7101006~ |
| 10 | M1346400004 | TERMINAL COVER | 1 | S/N7100001 TO S/N7100050; REPLACES M9310000304 |
| 11 | M1346400104 | TERMINAL COVER | 1 | S/N7100001 TO S/N7100050; REPLACES M9310000204 |
| 12 | 0016910020 | HEX. HEAD BOLT | 1 | S/N7100051~ |
| | 0040510000 | TOOTHED WASHER | 1 | S/N7100051~ |

ADD THE FOLLOWING DIGITS AFTER THE PART NUMBER
WHEN ORDERING ANY PAINTED PANEL TO INDICATE
COLOR OF UNIT:

| | |
|------------------|-----------------------|
| 1-ORANGE | 5 -BLACK |
| 2-WHITE | 6 -CATERPILLAR YELLOW |
| 3 -SPECTRUM GRAY | 7 -CATO GOLD |
| 4 -SUNBELT GREEN | 8 -RED |

THE SERIAL NUMBER MAY BE REQUIRED.

DCA-25SSIU --- MUFFLER ASSY.

MUFFLER ASSY.

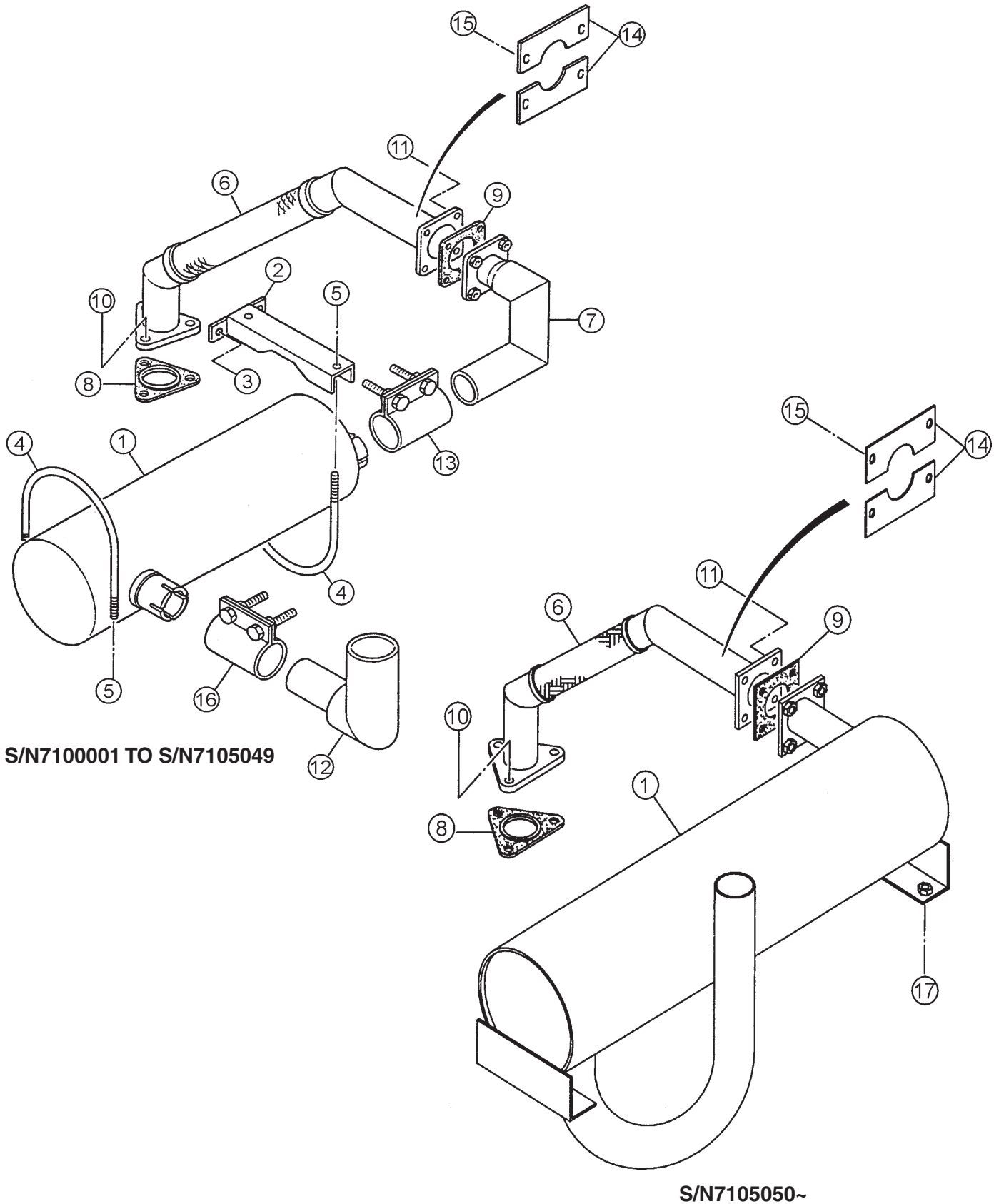

DCA-25SSIU --- MUFFLER ASSY.

MUFFLER ASSY.

| <u>NO.</u> | <u>PART NO.</u> | <u>ITEM</u> | <u>QTY.</u> | <u>REMARKS</u> |
|------------|-----------------|-------------------------|-------------|---|
| 1 | 0602300160 | MUFFLER;MAM060249 | 1 | S/N7100001 TO 7105049 |
| 1 | 0602300390 | MUFFLER | 1 | S/N7105050~ |
| 2 | M133040004 | MUFFLER SUPPORTER | 1 | S/N7100001 TO 7105049 |
| 3 | 011008020 | HEX. HEAD BOLT | 2 | REPLACES 0016908020; S/N7100001 TO 7105049 |
| 3 | 011008020 | HEX. HEAD BOLT | 4 | REPLACES 0016908020; S/N7105050~ |
| 4 | M1330400104 | U BOLT | 2 | S/N7100001 TO 7105049 |
| 5 | 020108060 | HEX. NUT | 4 | REPLACES 0037908000; S/N7100001 TO 7105049 |
| | 031108160 | PLAIN WASHER | 4 | REPLACES 0041208000; S/N7100001 TO 7105049 |
| 6 | M1333000703 | EXHAUST PIPE | 1 | |
| 7 | M1333000803 | EXHAUST PIPE | 1 | S/N7100001 TO 7105049 |
| 8 | 8943811610 | GASKET | 1 | REPLACES 0602320102 |
| 9 | M1333200004 | GASKET | 1 | S/N 7100001 TO S/N7100865 |
| | M1333200014 | GASKET | 1 | S/N7100866~ |
| 10 | 9098400850 | HEX. NUT | 3 | REPLACES 0602323001 |
| | 0040010000 | LOCK WASHER | 3 | |
| 11 | 0016908035 | HEX. HEAD BOLT | 4 | |
| 12 | M1333000604 | TAIL PIPE | 1 | S/N7100001 TO 7105049 |
| 13 | 0602325021 | SEAL CLAMP | 1 | S/N7100001 TO 7105049 |
| 14 | M1330400204 | COVER | 2 | |
| 15 | 011106015 | HEX. HEAD BOLT | 4 | REPLACES 0016906015 |
| 16 | 0602325020 | SEAL CLAMP | 1 | S/N7100001 TO 7105049 |
| 17 | 011008020 | HEX. HEAD BOLT | 4 | REPLACES 0016908020;S/N7105050~ |

ADD THE FOLLOWING DIGITS AFTER THE PART NUMBER
WHEN ORDERING ANY PAINTED PANEL TO INDICATE

COLOR OF UNIT:

| | |
|-----------------|----------------------|
| 1-ORANGE | 5-BLACK |
| 2-WHITE | 6-CATERPILLAR YELLOW |
| 3-SPECTRUM GRAY | 7-CATO GOLD |
| 4-SUNBELT GREEN | 8-RED |

THE SERIAL NUMBER MAY BE REQUIRED.

DCA-25SSIU --- FUEL TANK ASSY.

FUEL TANK ASSY.

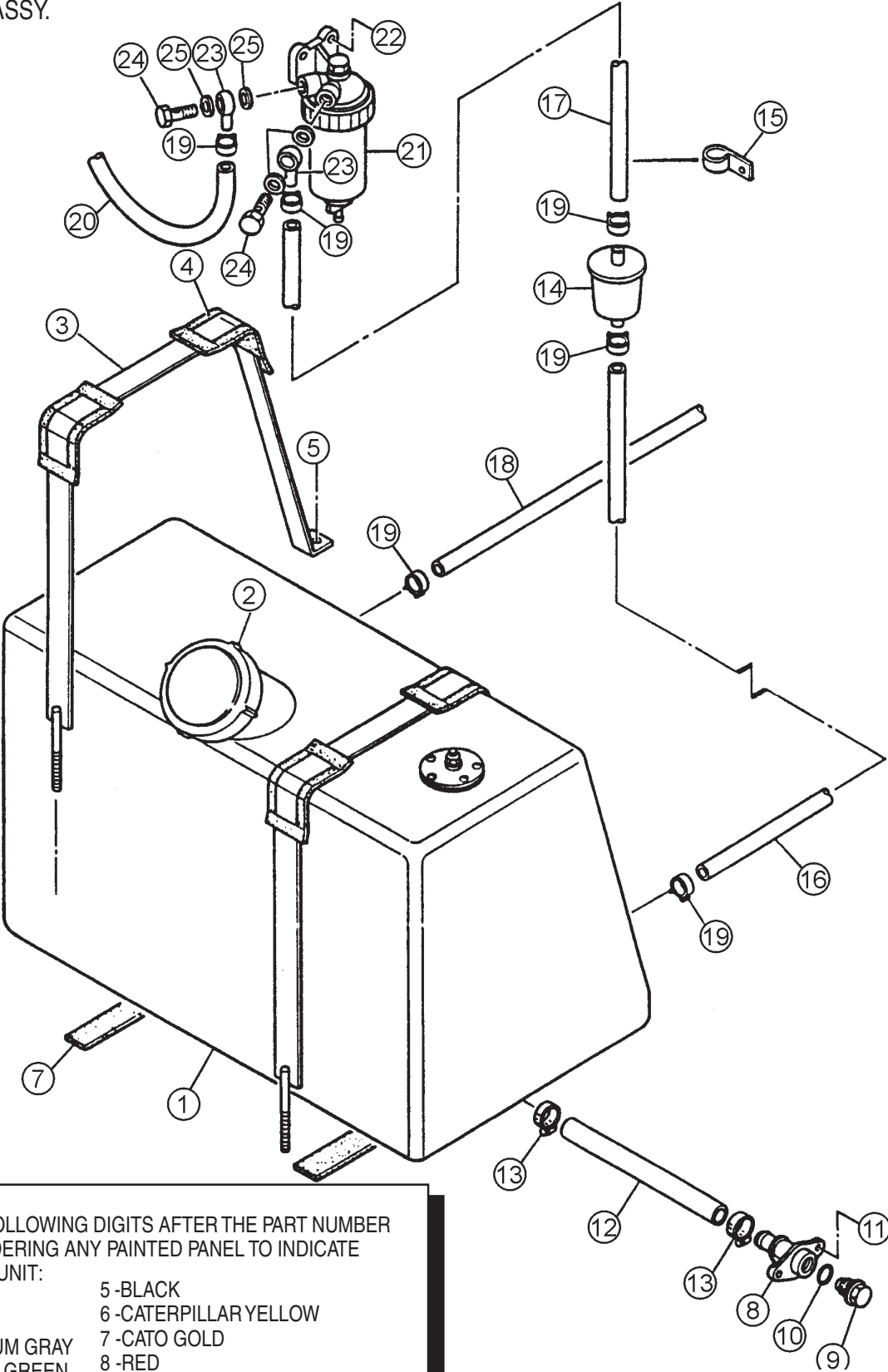

ADD THE FOLLOWING DIGITS AFTER THE PART NUMBER
WHEN ORDERING ANY PAINTED PANEL TO INDICATE
COLOR OF UNIT:

- | | |
|-----------------|----------------------|
| 1-ORANGE | 5-BLACK |
| 2-WHITE | 6-CATERPILLAR YELLOW |
| 3-SPECTRUM GRAY | 7-CATO GOLD |
| 4-SUNBELT GREEN | 8-RED |

THE SERIAL NUMBER MAY BE REQUIRED.

DCA-25SSIU --- FUEL TANK ASSY.

FUEL TANK ASSY.

| <u>NO.</u> | <u>PART NO.</u> | <u>ITEM</u> | <u>QTY.</u> | <u>REMARKS</u> |
|------------|-----------------|------------------------|-------------|--|
| 1 | M1363000202 | FUEL TANK | 1 | |
| 2 | 0605505070 | CAP, FUEL TANK | 1 | |
| 3 | M1363200004 | TANK BAND | 2 | |
| 4 | M9310500104 | SUPPORTER SHEET | 4 | |
| 5 | 011008020 | HEX. HEAD BOLT | 2 | REPLACES 0016908020 |
| 6 | 00379080000 | HEX. NUT | 2 | S/N7100001 TO S/N7101449; REPLACES 0037908000 |
| | 0207308000 | HEX. NUT | 2 | S/N7101450~ |
| | 031108160 | PLAIN WASHER | 2 | S/N7100001 TO S/N7101449; REPLACES 0041208000 |
| 7 | 0222100080 | RUBBER SHEET | 4 | |
| 8 | 1502025103C | DRAIN JOINT | 1 | REPLACES M9200000003 |
| 9 | M9200200004 | DRAIN BOLT | 1 | |
| 10 | 0150000018 | O RING | 1 | |
| 11 | 011206020 | HEX. HEAD BOLT | 2 | REPLACES 0016906020 |
| 12 | M1363400104 | DRAIN HOSE | 1 | |
| 13 | 06015515198 | HOSE BAND | 2 | REPLACES 0605515064 |
| 14 | 0602042420 | FUEL FILTER | 1 | PTG15P |
| 15 | 0602220911 | CLAMP | 1 | |
| 16 | 0191300730 | SUCTION HOSE | 1 | |
| 17 | 0191300380 | SUCTION HOSE | 1 | S/N7100001 TO S/N7102685 |
| | 0191300920 | SUCTION HOSE | 1 | S/N7102686~ |
| 18 | 0191301060 | RETURN HOSE | 1 | |
| 19 | 0605515109 | HOSE BAND | 6 | S/N7100001 TO S/N7102685 |
| | 0605515109 | HOSE BAND | 8 | S/N7102686~ |
| 20 | 0191300520 | SUCTION HOSE | 1 | S/N7102686~ |
| 21 | 1132008410 | WATER SEDIMENTER | 1 | S/N7102686~; REPLACES 0602042512 |
| 22 | 0016908025 | HEX. HEAD BOLT | 2 | S/N7102686~ |
| 23 | 5154115680 | PIPE | 2 | S/N7102686~; REPLACES 0602042660 AND 5154112231 |
| 24 | 1096751460 | JOINT BOLT | 2 | S/N7102686~; REPLACES 0602042620 AND 9099063251 |
| 25 | 9095720140 | PACKING | 4 | S/N7102686~; REPLACES 0602042640 |

DCA-25SSIU --- ENCLOSURE ASSY.

ENCLOSURE ASSY.

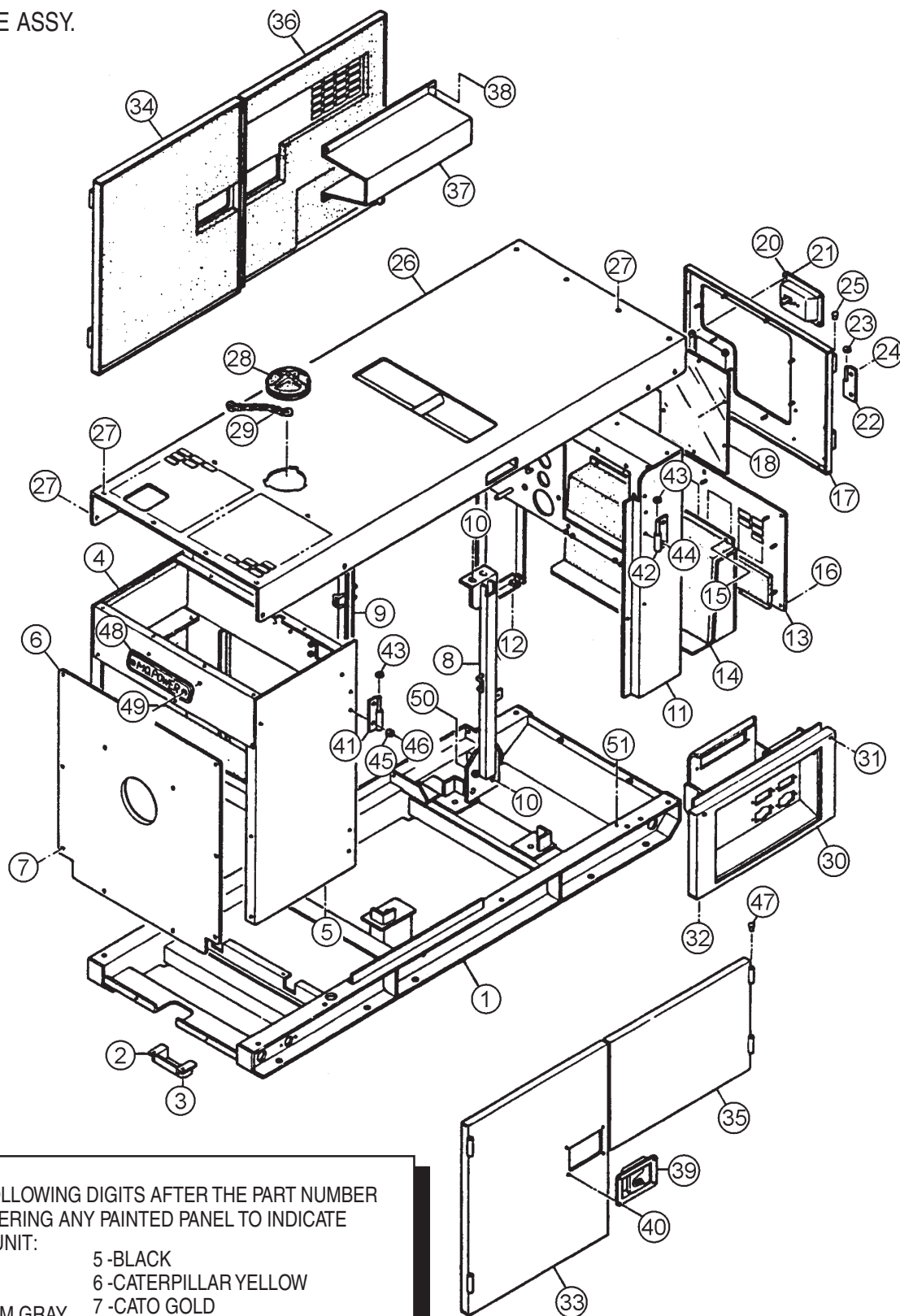

ADD THE FOLLOWING DIGITS AFTER THE PART NUMBER
WHEN ORDERING ANY PAINTED PANEL TO INDICATE
COLOR OF UNIT:

- | | |
|-----------------|----------------------|
| 1-ORANGE | 5-BLACK |
| 2-WHITE | 6-CATERPILLAR YELLOW |
| 3-SPECTRUM GRAY | 7-CATO GOLD |
| 4-SUNBELT GREEN | 8-RED |

THE SERIAL NUMBER MAY BE REQUIRED.

DCA-25SSIU --- ENCLOSURE ASSY.

ENCLOSURE ASSY.

| <u>NO.</u> | <u>PART NO.</u> | <u>ITEM</u> | <u>QTY.</u> | <u>REMARKS</u> |
|------------|-----------------|----------------------|-------------|--|
| 1 | M1413000212 | BASE | 1 | S/N7100291 TO S/N7104749 REPLACES M1413000202 |
| | M1413000222 | BASE | 1 | S/N7104750~ |
| 2 | M1413400004 | UNDER COVER | 1 | |
| 3 | 011008020 | HEX. HEAD BOLT | 2 | REPLACES 0016908020 |
| 4 | M1423000302 | FRONT FRAME | 1 | S/N7100001 TO 7105049 |
| | M1493100503 | ACOUSTIC SHEET | 1 | S/N7100001 TO 7105049 |
| | M1423000312 | FRONT FRAME | 1 | S/N7105050~ |
| | M1493100513 | ACOUSTIC SHEET | 1 | S/N7105050~ |
| 5 | 011008020 | HEX.HEAD BOLT | 4 | REPLACES 0016908020 |
| 6 | M1423200304 | COVER, FRONT FRAME | 1 | |
| | M1493100604 | ACOUSTIC SHEET | 1 | |
| 7 | 011008020 | HEX HEAD BOLT | 11 | REPLACES 0016908020 |
| 8 | M1433000203 | CENTER FRAME | 1 | |
| 9 | M1433000303 | CENTER FRAME | 1 | |
| 10 | 0010114030 | HEX. HEAD BOLT | 8 | |
| | 030214350 | LOCK WASHER | 8 | REPLACES 0040014000 |
| | 031114260 | PLAIN WASHER | 8 | REPLACES 0041214000 |
| 11 | M1443000502 | REAR FRAME | 1 | |
| 12 | 011008020 | HEX. HEAD BOLT | 4 | REPLACES 0016908020 |
| | 0040508000 | TOOTHED WASHER | 1 | |
| 13 | M1443300513 | REAR COVER | 1 | REPLACES M1443300503 |
| | M1493300304 | ACOUSTIC SHEET | 1 | |
| 14 | M1443300403 | DUCT, REAR COVER | 1 | |
| | M1493300404 | ACOUSTIC SHEET | 1 | |
| 15 | 0207006000 | HEX. NUT | 7 | |
| 16 | 011008020 | HEX. HEAD BOLT | 6 | S/N7100001 TO S/N7100290; REPLACES 0016908020 |
| | 011008020 | HEX. HEAD BOLT | 7 | S/N7100291~; REPLACES 0016908020 |
| 17 | M1443200613 | REAR DOOR | 1 | REPLACES M1443200603 |
| 18 | M1443600004 | WINDOW PLATE | 1 | S/N7100001 TO S/N7100725 |
| | M1443600104 | WINDOW PLATE | 1 | S/N7100726 TO S/N7101589 |
| | M1443600114 | WINDOW PLATE | 1 | S/N7101590~ |
| 19 | 020106050 | HEX. NUT | 6 | S/N7100001 TO S/N7101449; REPLACES 0037906000 |
| | 0027306000 | HEX. NUT | 6 | S/N7101450 TO S/N7101589 |
| | 0207306000 | HEX. NUT | 8 | S/N7101590~ |
| | 952404470 | PLAIN WASHER | 12 | S/N7100001 TO S/N7101449; REPLACES 0041206000 |
| | 952404470 | PLAIN WASHER | 6 | S/N7101450 TO S/N7101589; REPLACES 0041206000 |
| | 952404470 | PLAIN WASHER | 8 | S/N7101590~; REPLACES 0041206000 |
| 20 | M911300002 | DOOR HANDLE ASSY. | 1 | |
| 21 | 0021706015 | MACHINE SCREW | 4 | |
| | 020106050 | HEX. NUT | 4 | REPLACES 0030006000 |

DCA-25SSIU --- ENCLOSURE ASSY.

ENCLOSURE ASSY.

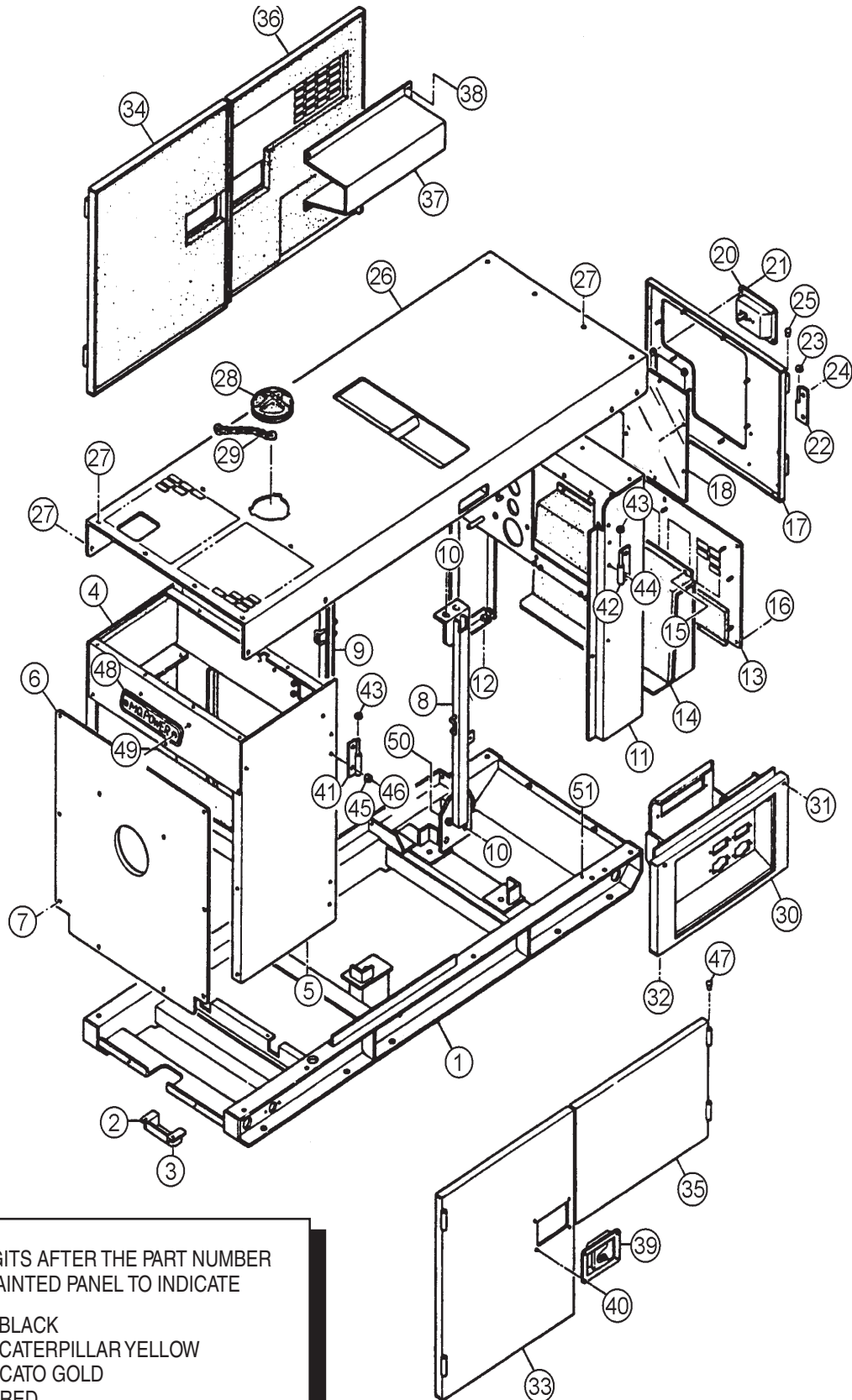

ADD THE FOLLOWING DIGITS AFTER THE PART NUMBER
WHEN ORDERING ANY PAINTED PANEL TO INDICATE
COLOR OF UNIT:

- | | |
|-----------------|----------------------|
| 1-ORANGE | 5-BLACK |
| 2-WHITE | 6-CATERPILLAR YELLOW |
| 3-SPECTRUM GRAY | 7-CATO GOLD |
| 4-SUNBELT GREEN | 8-RED |

THE SERIAL NUMBER MAY BE REQUIRED.

DCA-25SSIU --- ENCLOSURE ASSY.

ENCLOSURE ASSY.

| <u>NO.</u> | <u>PART NO.</u> | <u>ITEM</u> | <u>QTY.</u> | <u>REMARKS</u> |
|------------|-----------------|-----------------------|-------------|--------------------------|
| 22 | M9110100204 | HINGE | 2 | |
| 23 | M9116100004 | WASHER | 2 | |
| 24 | 0021808020 | MACHINE SCREW | 3 | |
| 25 | 0845031504 | BLIND PLUG | 2 | REPLACES M9310000004 |
| 26 | M1463000202 | ROOF PANEL | 1 | S/N7100000 TO S/N7104749 |
| 26 | M1463000212 | ROOF PANEL | 1 | S/N7104750 TO S/N7105049 |
| | M1463000222 | ROOF PANEL | 1 | S/N7105050~ |
| | M1493500203 | ACOUSTIC SHEET | 1 | S/N7100000 TO S/N7104749 |
| | M1493500203 | ACOUSTIC SHEET | 1 | S/N7104750~ |
| 27 | 011008020 | HEX. HEAD BOLT | 18 | REPLACES 0016908020 |
| 28 | 1625165103 | BONNET CAP | 1 | REPLACES M9310000103 |
| 29 | 1625165204 | CHAIN ASSY..... | 1 | REPLACES M1483600204 |
| 30 | M1443100202 | SPLASHER PANEL | 1 | S/N7100001 TO S/N7102784 |
| | M1443100212 | SPLASHER PANEL | 1 | S/N7102785 |
| 31 | 0016908050 | HEX. HEAD BOLT | 2 | |
| 32 | 011008020 | HEX. HEAD BOLT | 2 | REPLACES 0016908020 |
| 33 | M1453000703 | SIDE DOOR | 1 | |
| | M1493400904 | ACOUSTIC SHEET | 1 | |
| 34 | M1453000903 | SIDE DOOR | 1 | |
| | M1493401004 | ACOUSTIC SHEET | 1 | |
| 35 | M1453001003 | SIDE DOOR | 1 | |
| | M1493401104 | ACOUSTIC SHEET | 1 | |
| 36 | M1453000803 | SIDE DOOR | 1 | |
| | M1493400804 | ACOUSTIC SHEET | 1 | |
| 37 | M1453300503 | DUCT | 1 | |
| 38 | 0207006000 | HEX. NUT | 4 | |
| 39 | B9114000002 | DOOR HANDLE ASSY..... | 3 | REPLACES M9113000002 |
| 40 | 0027106016 | MACHINE SCREW | 12 | REPLACES 0021806015 |
| | 020106050 | HEX. NUT | 12 | REPLACES 0030006000 |
| 41 | M9110100204 | HINGE | 4 | |
| 42 | M9110100304 | HINGE | 4 | |
| 43 | M9116100004 | WASHER | 8 | |
| 44 | 0021808020 | MACHINE SCREW | 9 | |
| 45 | 0601850097 | DOOR STOPPER | 8 | |
| 46 | 0027208025 | MACHINE SCREW | 8 | |
| 47 | 0845031504 | BLIND PLUG | 8 | REPLACES M9310000004 |
| 48 | 0600500090 | EMBLEM | 1 | |
| 49 | 0021106015 | MACHINE SCREW | 2 | |
| 50 | 012210025 | HEX. HEAD BOLT | 1 | REPLACES 0016910025 |
| | 0040510000 | TOOTHED WASHER | 1 | |
| 51 | 011008020 | HEX. HEAD BOLT | 1 | REPLACES 0016908020 |
| | 0040508000 | TOOTHED WASHER | 1 | |

DCA-25SSIU --- RUBBER SEAL ASSY.

RUBBER SEAL ASSY.

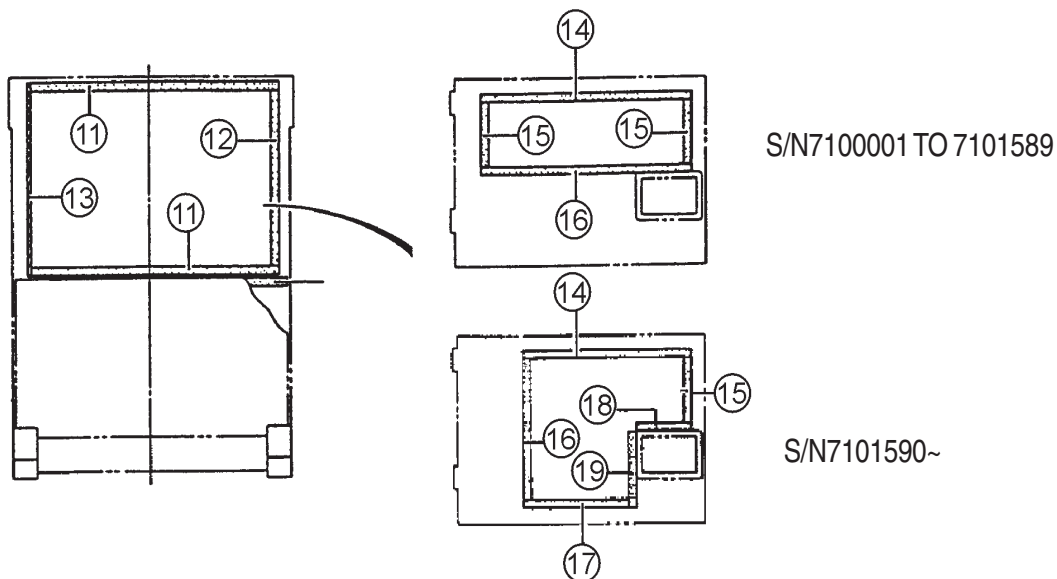
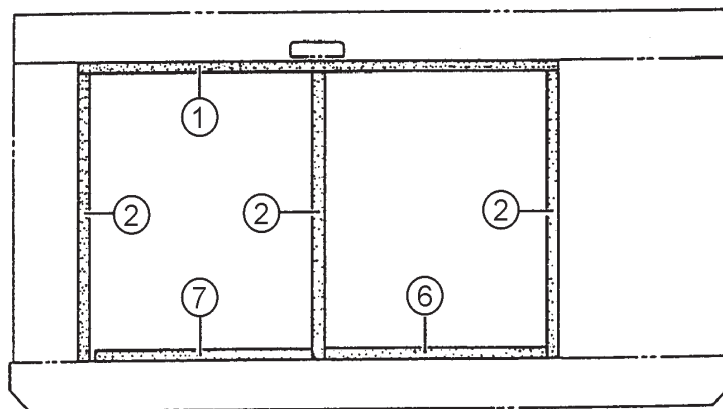
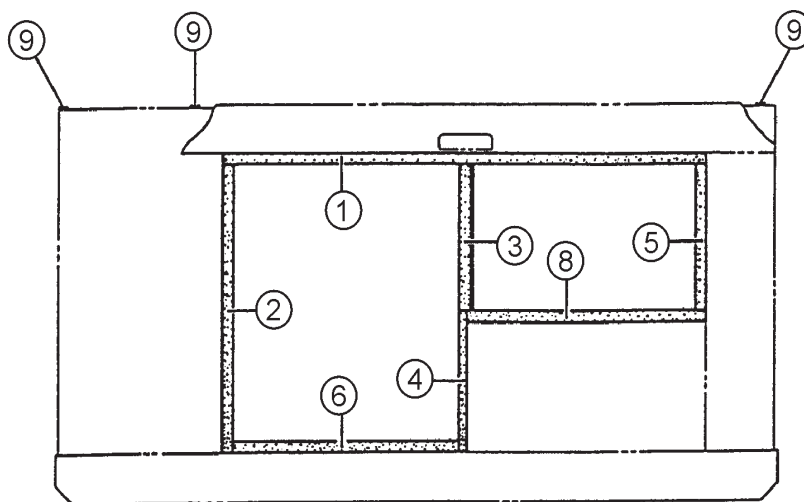

DCA-25SSIU --- RUBBER SEAL ASSY.

RUBBER SEAL ASSY.

| <u>NO.</u> | <u>PART NO.</u> | <u>ITEM</u> | <u>QTY.</u> | <u>REMARKS</u> |
|------------|-----------------|-------------------|-------------|--------------------------|
| 1 | 0228910300 | RUBBER SEAL | 2 | |
| 2 | 0228900725 | RUBBER SEAL | 4 | |
| 3 | M1490300004 | RUBBER SEAL | 1 | |
| 4 | 0228800360 | RUBBER SEAL | 1 | |
| 5 | 0228900370 | RUBBER SEAL | 1 | |
| 6 | 0228800605 | RUBBER SEAL | 2 | |
| 7 | 0229200595 | RUBBER SEAL | 1 | |
| 8 | 0228900645 | RUBBER SEAL | 1 | |
| 9 | 0229200750 | RUBBER SEAL | 3..... | S/N7100001 TO S/N7101589 |
| | 0229200750 | RUBBER SEAL | 2..... | S/N7101590~ |
| 10 | 0229200740 | RUBBER SEAL | 1 | |
| 11 | 0228800670 | RUBBER SEAL | 2 | |
| 12 | 0228800445 | RUBBER SEAL | 1 | |
| 13 | 0228800485 | RUBBER SEAL | 1 | |
| 14 | 0228100568 | RUBBER SEAL | 2..... | S/N7100001 TO S/N7101589 |
| | 0228100458 | RUBBER SEAL | 1..... | S/N7101590~ |
| 15 | 0228100170 | RUBBER SEAL | 2..... | S/N7100001 TO S/N7101589 |
| | 0228100171 | RUBBER SEAL | 1..... | S/N7101590~ |
| 16 | 0228100351 | RUBBER SEAL | 1..... | S/N7101590~ |
| 17 | 0228100285 | RUBBER SEAL | 1..... | S/N7101590~ |
| 18 | 0228100153 | RUBBER SEAL | 1..... | S/N7101590~ |
| 19 | 0228100180 | RUBBER SEAL | 1..... | S/N7101590~ |

DECAL ASSY.

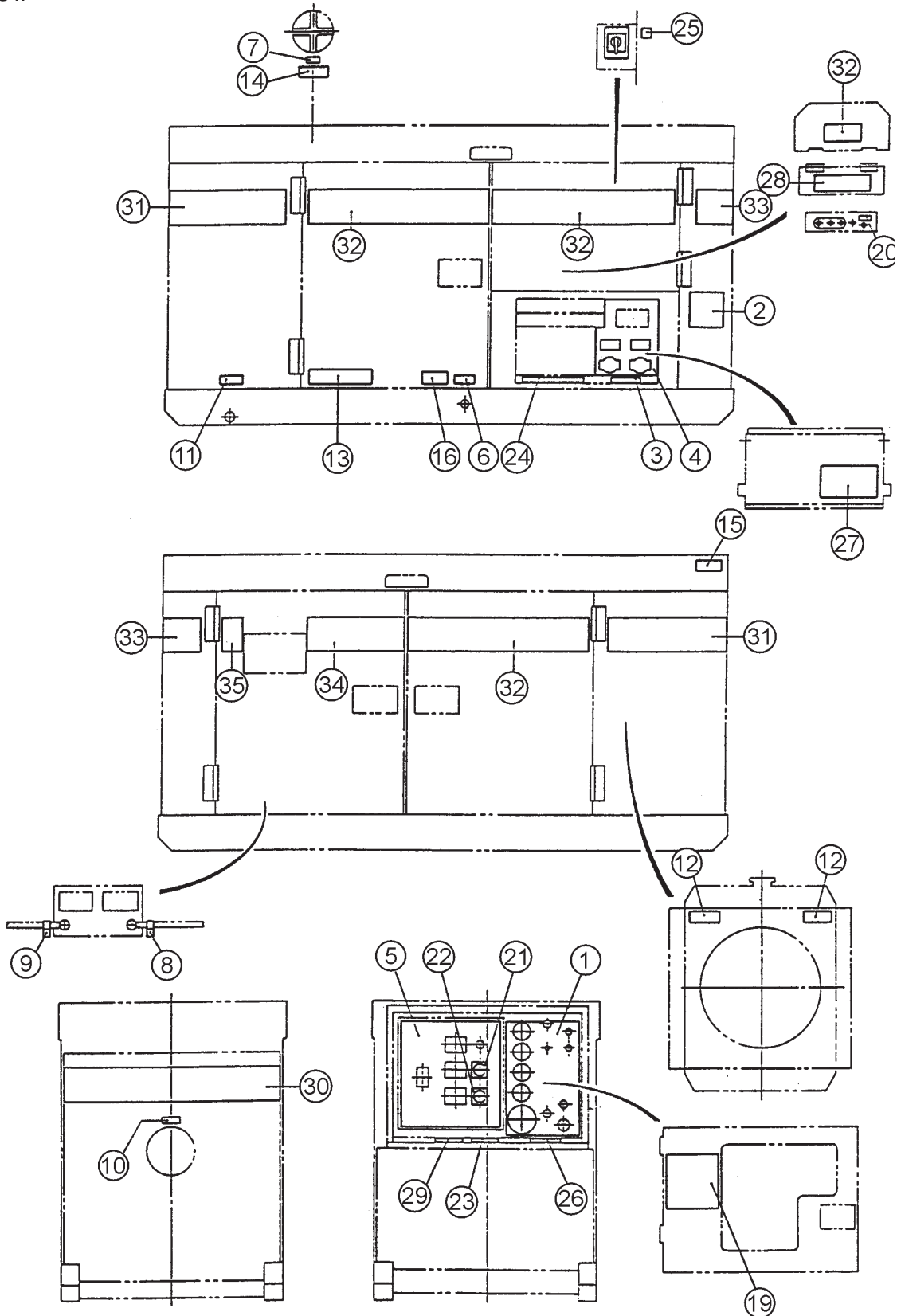

DECAL ASSY.

| <u>NO.</u> | <u>PART NO.</u> | <u>ITEM</u> | <u>QTY.</u> | <u>REMARKS</u> |
|------------|-----------------|---|-------------|--|
| 1 | M1550000003 | DECAL; ENGINE OPERATING | 1 | M15000000 |
| 2 | M1550000104 | DECAL; NOTE | 1 | M15000010 |
| 3 | M1550000204 | DECAL; NOTE | 1 | M15000020 |
| 4 | M1550000303 | DECAL; AUXILLARY OUTPUT | 1 | M15000030 |
| 5 | M1550000403 | DECAL; GENERATOR CONTROL | 1 | M15000040 |
| 6 | M9500000004 | DECAL; OIL DRAIN PLUG | 1 | M90000000 |
| 7 | M9500100004 | DECAL; WATER | 1 | M90010000 |
| 8 | M9500300004 | DECAL; - | 1 | M90030000 |
| 9 | M9500300104 | DECAL; + | 1 | M90030010 |
| 10 | M9500500004 | DECAL; DIESEL FUEL | 1 | M90050000 |
| 11 | M9500500104 | DECAL; FUEL DRAIN PLUG | 1 | M90050010 |
| 12 | M9503000004 | DECAL; WARNING | 2 | M90300000 |
| 13 | M9503000103 | DECAL; WATER, OIL CHECK | 1 | M90300000 |
| 14 | M9503100004 | DECAL; WARNING | 1 | M90310000 |
| 15 | M9503200004 | DECAL; WARNING | 1 | M90320000 |
| 16 | M9510100004 | DECAL; CAUTION | 1 | M91010000 |
| 17 | M9520100503 | DECAL; WARNING | 1 | S/N7100001 TO 7100600; REPLACES M9510100104 |
| 18 | M9520100503 | DECAL; WARNING | 1 | S/N7100001 TO 7100600; REPLACES M9510100204 |
| 19 | M9510200002 | DECAL; MQ | 1 | M91020000 |
| 20 | M9520000004 | DECAL; GROUND | 1 | M92000000 |
| 21 | M9520000104 | DECAL; AMMETER CHANGE OVER SWITCH | 1 | M92000010 |
| 22 | M9520000204 | DECAL; VOLTMETER CHANGE OVER SWITCH .. | 1 | M92000020 |
| 23 | M9520100004 | DECAL; WARNING | 2 | M92010000 |
| 24 | M9520100503 | DECAL; WARNING | 1 | S/N7100001 TO 7100600; REPLACES M9520100104 |
| | M9520100503 | DECAL; WARNING | 1 | M92010050 M9100601~ |
| 25 | M9520100204 | DECAL; CAUTION | 1 | M92010020A |
| 26 | M9520100304 | DECAL; SAFETY INSTRUCTIONS | 1 | M92010030 |
| 27 | M9520100404 | DECAL; DANGER | 1 | M92010040 |
| 28 | M9520200003 | DECAL; CONNECTION OF OUTPUT CABLE | 1 | M92020000 |
| 29 | M9520200104 | DECAL; OVER CURRENT RELAY | 1 | M92020010 |
| 30 | M1560100403 | STRIPE; WHISPERWATT | 1 | |
| 31 | M1560100303 | STRIPE; MQ POWER | 2 | |
| 32 | M1560100004 | STRIPE; | 3 | |
| 33 | M1560100504 | STRIPE; 25 | 2 | |
| 34 | M1560100104 | STRIPE | 1 | |
| 35 | M1560100204 | STRIPE | 1 | |

ISUZU C240 --- CYLINDER HEAD AND COVER ASSY.

CYLINDER HEAD AND COVER ASSY.

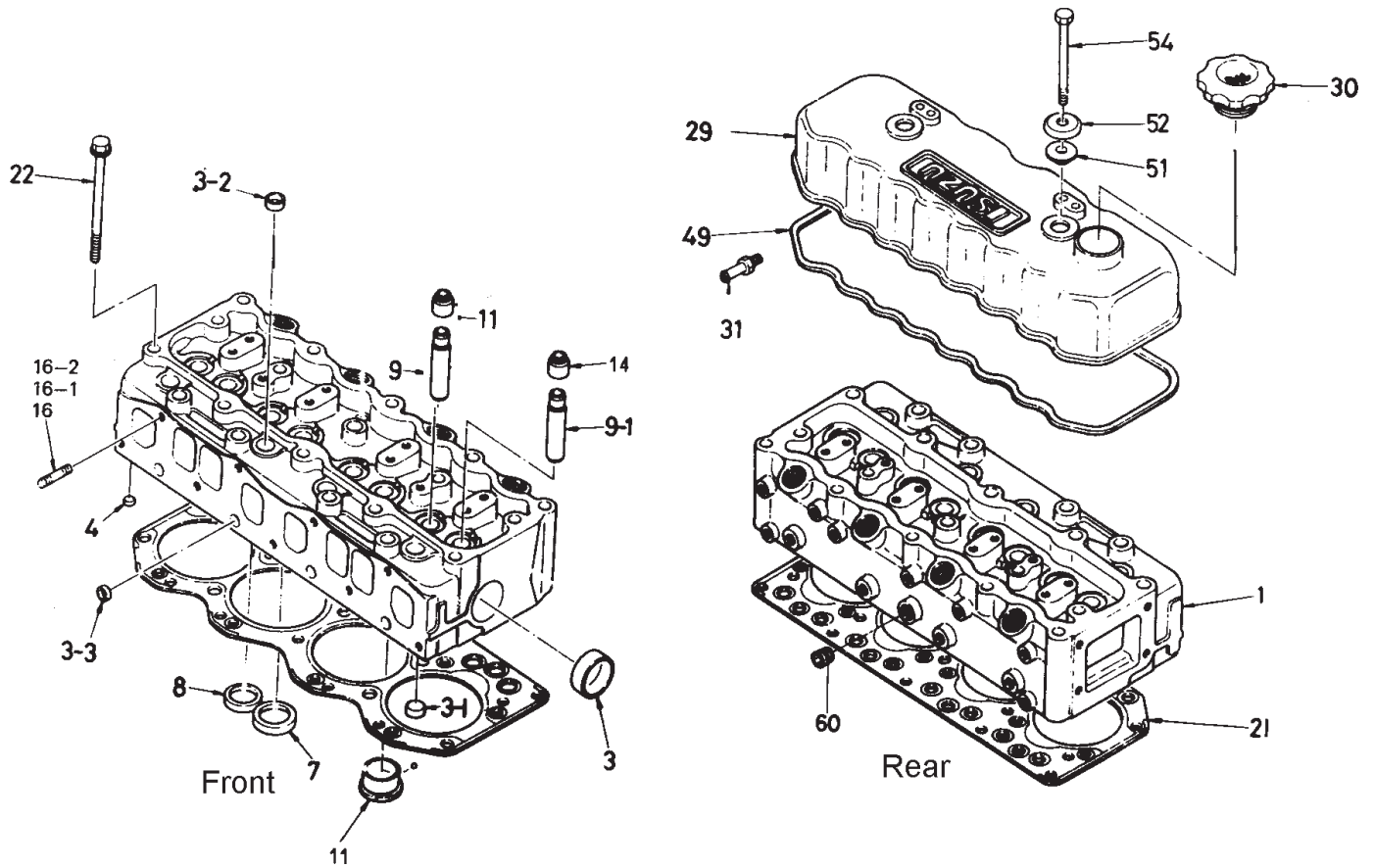

ISUZU C240 --- CYLINDER HEAD AND COVER ASSY.

CYLINDER HEAD AND COVER ASSY.

| <u>NO.</u> | <u>PART NO.</u> | <u>ITEM</u> | <u>QTY.</u> | <u>REMARKS</u> |
|------------|-----------------|---------------------------------|-------------|----------------|
| 1 | 5111102070 | CYLINDER HEAD ASSY. | 1 | |
| 3 | 1096000051 | SEALING CUP, RR FACE D=44 | 1 | |
| 3-1 | 5111290060 | SEALING CUP, LOWER D=16 | 4 | |
| 3-2 | 5112190080 | SEALING CUP, UPPER D=18 | 5 | |
| 3-3 | 5096000130 | SEALING CUP, DRILLED D=12 | 4 | |
| 4 | 9098605220 | PLUG; LOWER CYLINDER HEAD PLATE | 4 | |
| 7 | 5117150230 | VALVE SEAT INLET INSERT | 4 | |
| 8 | 5117110260 | VALVE SEAT EXHAUST INSERT | 4 | |
| 9 | 5117210160 | VALVE INLET HEAD GUIDE | 4 | |
| 9-1 | 5117210160 | VALVE EXHAUST HEAD GUIDE | 4 | |
| 11 | 5111501080 | HOT PLUG ASSY. | 4 | |
| 14 | 5125690060 | INLET AND EXHAUST VALVE SEAL | 8 | |
| 16 | 9041108350 | MANIFOLD STUD | 3 | |
| 16-1 | 9041108400 | MANIFOLD STUD | 3 | |
| 16-2 | 9041108450 | MANIFOLD STUD | 1 | |
| 21 | 5111410690 | CYLINDER HEAD GASKET | 1 | |
| 22 | 5090090530 | BOLT | 19 | |
| 29 | 5111702400 | CYLINDER HEAD COVER ASSY. | 1 | |
| 30 | 9117510381 | OIL FILLER CAP | 1 | |
| 31 | 5111790520 | BREATHER NIPPLE | 1 | |
| 49 | 5111730170 | HEAD COVER PACKING | 1 | |
| 51 | 9111798080 | HEAD COVER FIX. PACKING | 2 | |
| 52 | 9111791320 | WAHER | 2 | |
| 54 | 5090000960 | BOLT | 2 | |
| 60 | 5096050050 | CYLINDER HEAD OIL COOLER PLUG | 1 | |

ISUZU C240 --- CYLINDER BLOCK ASSY.

CYLINDER BLOCK ASSY.

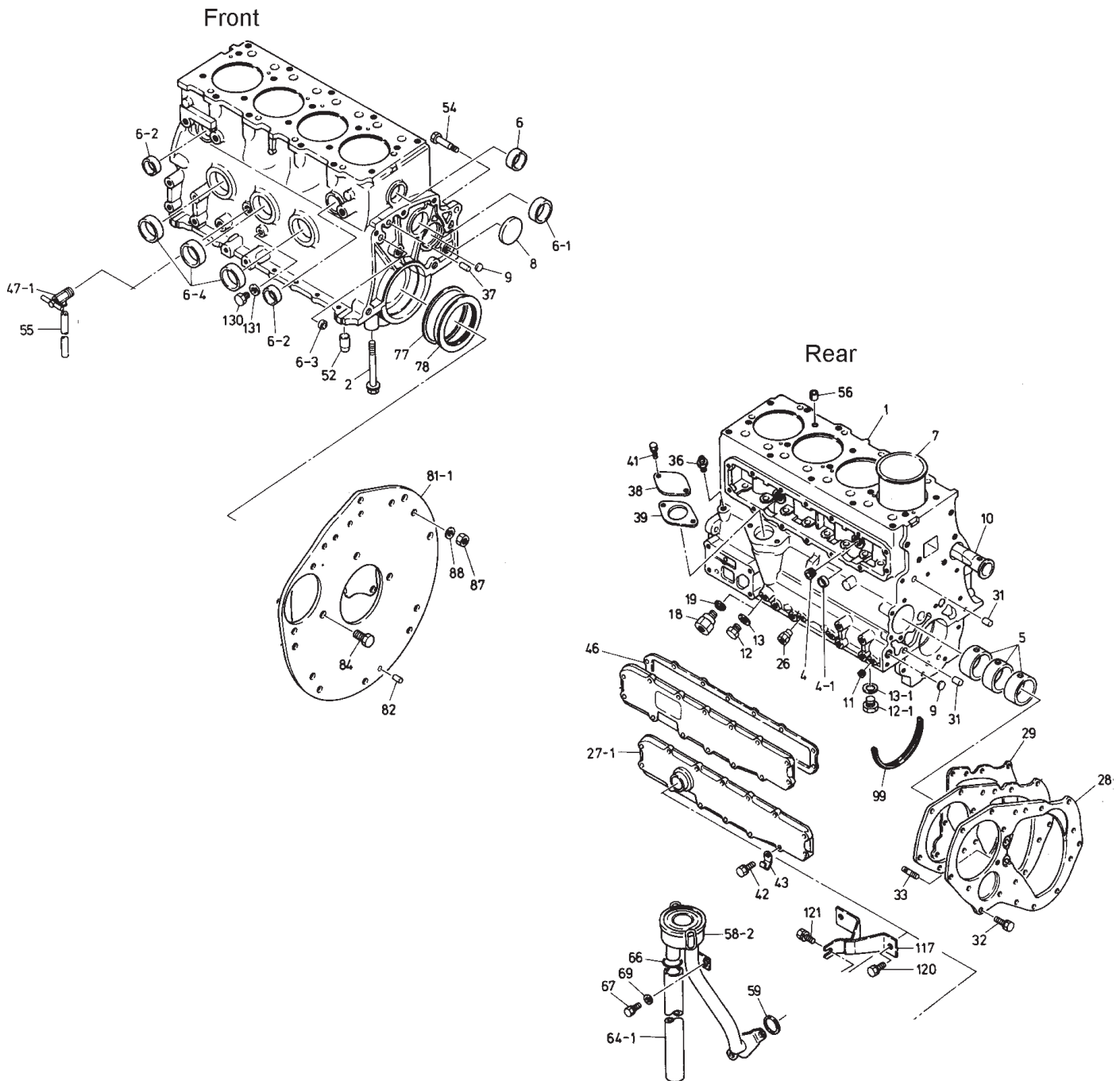

ISUZU C240 --- CYLINDER BLOCK ASSY.

CYLINDER BLOCK ASSY.

| <u>NO.</u> | <u>PART NO.</u> | <u>ITEM</u> | <u>QTY.</u> | <u>REMARKS</u> |
|------------|-----------------|-----------------------------|-------------|---------------------|
| 1 | 5112101771 | CYLINDER BLOCK ASSY. | 1 | |
| 2 | 9098025910 | BOLT | 10 | |
| 4 | 9096640340 | PLUG; 1/2 TAPPET CHAMBER | 2 | |
| 4-1 | 5112190080 | SEALING CUP CHAMBER D=18 | 2 | |
| 5 | 5116100010 | BEARING KIT; CAM. STANDARD | 1 | |
| 6 | 5112190180 | SEALING CUP RR FACE D=36 | 1 | |
| 6-1 | 5112190170 | SEALING CUP RR FACE D=38 | 1 | |
| 6-2 | 5112190150 | SEALING CUP LH SIDE D=32 | 2 | |
| 6-3 | 5096000130 | SEALING CUP RR FACE D=12 | 1 | |
| 6-4 | 1096000051 | SEALING CUP LH SIDE D=45 | 3 | |
| 7 | 9112612300 | CYLINDER LINER | 4 | |
| 8 | 8942505140 | PLUG; CAMSHAFT BRIDGE PLATE | 1 | |
| 9 | 5111290060 | PLUG; OIL GALLERY PLATE | 2 | |
| 10 | 5112210020 | DUCT; CYL. BLOCK WATER | 1 | |
| 11-1 | 5096050161 | PLUG; OIL GALLERY 1/8 | 1 | |
| 12-1 | 9992023160 | PLUG; OIL GALLERY SCREW | 1 | |
| 13-1 | 9095714160 | PLUG PACKING | 1 | |
| 26 | 5096500210 | INJ. PUMP OIL FEED NIPPLE | 1 | |
| 27-1 | 9112976500 | TAPPET CHAMBER COVER ASSY. | 1 | |
| 28 | 9113111530 | FRONT CYL. BLOCK PLATE | 1 | |
| 29 | 5113120110 | FRONT PLATE PACKING | 1 | |
| 31 | 9081510240 | FRONT PLATE STRAIGHT PIN | 2 | |
| 32 | 9019008220 | BOLT | 3 | |
| 36 | 9099022990 | ROCKER OIL FEED NIPPLE | 1 | |
| 37 | 9081610320 | REAR PLATE STRAIGHT PIN | 1 | |
| 42-1 | 9019008180 | BOLT | 12 | |
| 42-2 | 9019008220 | BOLT | 2 | |
| 43 | 9099168160 | TAPPET CHAMBER COVER CLIP | 2 | |
| 46 | 5112920110 | CHAMBER COVER PACKING..... | 1 | REPLACES 5112920150 |
| 47-1 | 9097040380 | WATER DRAIN COCK | 1 | |
| 52 | 9098785970 | CRANK CASE PIN | 2 | |
| 54-2 | 8942008311 | BOLT | 1 | |
| 55 | 9099138340 | PIPE; VINYL WATER DRAIN | 1 | |
| 56 | 9112290490 | CYLINDER BLOCK DOWEL | 2 | |
| 58-2 | 5117400211 | BREATHER AIR ASSY. | 1 | |
| 59 | 9099210990 | BREATHER PACKING | 1 | |
| 64-1 | 9097130870 | PIPE; VINYL BREATHER | 1 | |
| 66 | 9099152380 | CLIP | 1 | |
| 67 | 9019008180 | BOLT | 1 | |
| 69 | 9091645080 | WASHER | 1 | |
| 77 | 9123631120 | SPACER; OIL SEAL | 1 | |
| 78 | 5096250360 | CRANK SHAFT REAR SEAL | 1 | |
| 81 | 9113411940 | REAR CYLINDER BLOCK PLATE | 1 | |
| 84 | 5090002270 | BOLT | 3 | |
| 99 | 9112581080 | OIL PAN BRIDGE CAP PACKING | 2 | |
| 117 | 5117490340 | BREATHER HEAD PACKING | 1 | |
| 120 | 9019008180 | BOLT | 2 | |
| 121 | 9019608180 | BOLT | 1 | |
| 130 | 9092023080 | PLUG; OIL GALLERY SCREW | 1 | |
| 131 | 9095714080 | SCREW PLUG PACKING | 1 | |

ISUZU C240 ---TIMING GEAR ASSY.

TIMING GEAR ASSY.

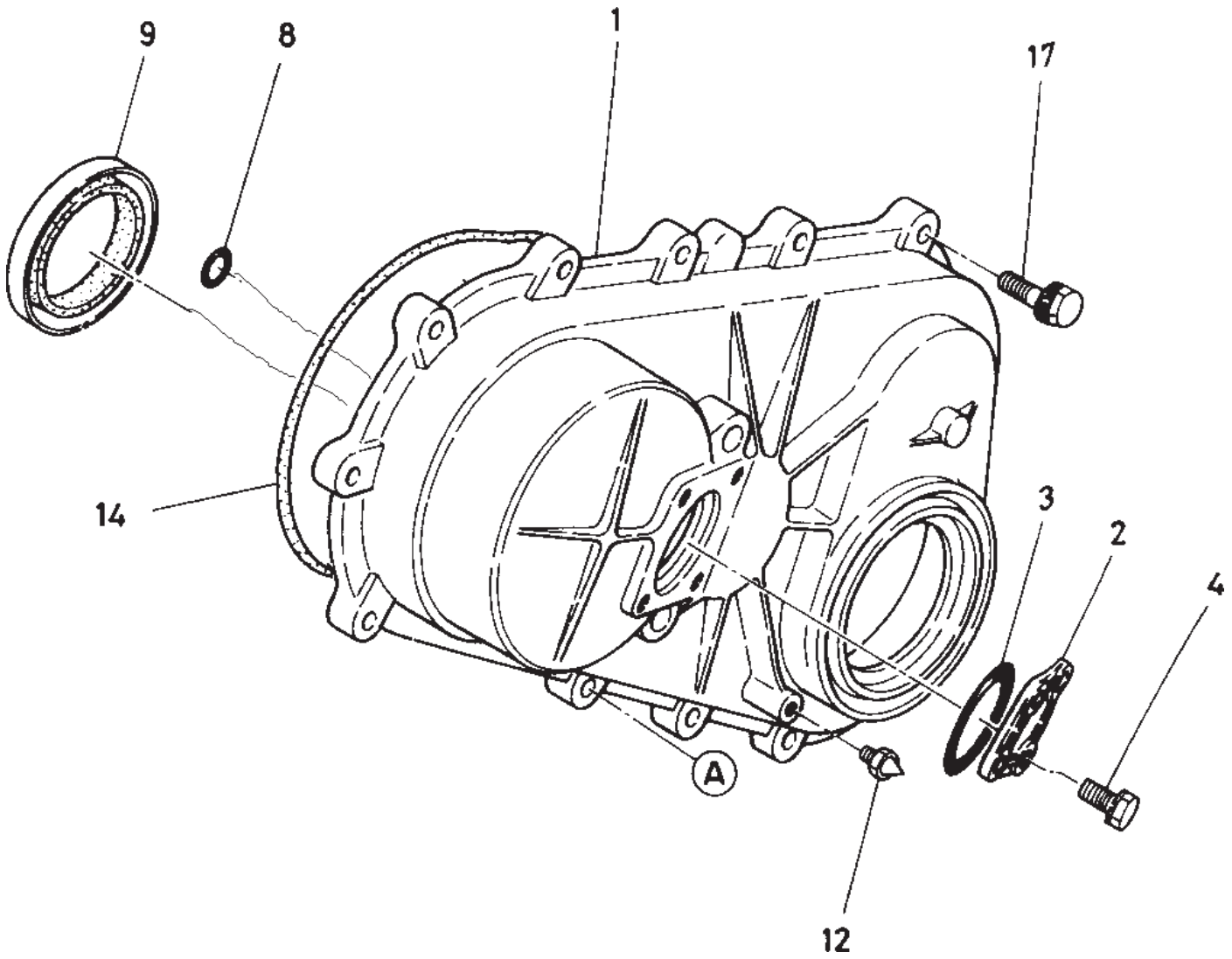

ISUZU C240 --- TIMING GEAR ASSY.

TIMING GEAR ASSY.

| <u>NO.</u> | <u>PART NO.</u> | <u>ITEM</u> | <u>QTY.</u> | <u>REMARKS</u> |
|------------|-----------------|------------------|-------------|----------------|
| 1 | 5113110282 | TIMING GEAR CASE | 1 | |
| 2 | 9113211480 | GEAR CASE COVER | 1 | |
| 3 | 9099206010 | PACKING | 1 | |
| 4 | 901906140 | BOLT | 4 | |
| 8 | 9113120460 | PACKING | 2 | |
| 9 | 5096250790 | OIL SEAL | 1 | |
| 12 | 9113270450 | POINTER | 1 | |
| 14 | 9113120340 | PACKING | 1 | |
| 17 | 9019108320 | BOLT | 9 | |

ISUZU C240 FLYWHEEL HOUSING ASSY.

FLYWHEEL HOUSING ASSY.

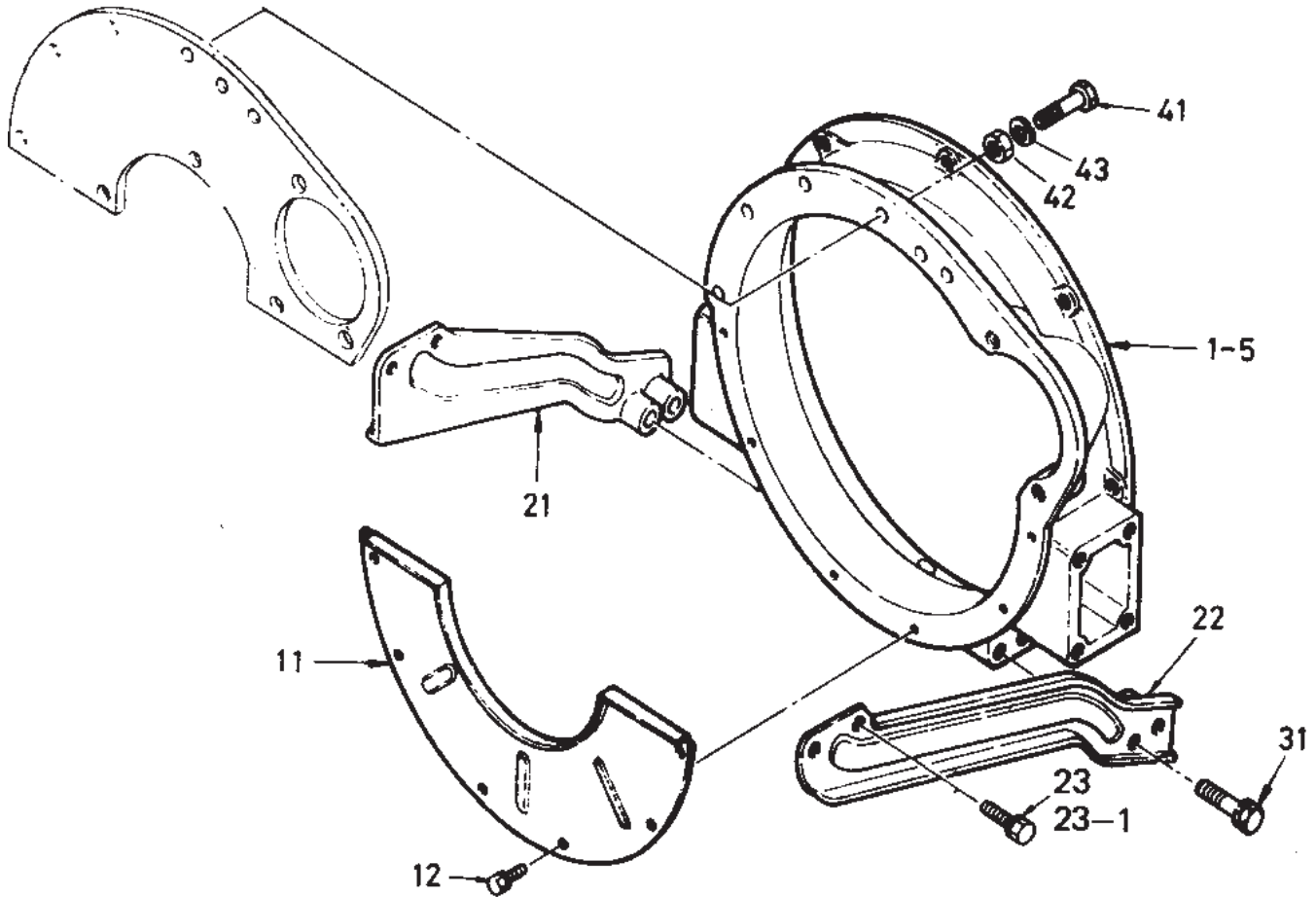

ISUZU C240 FLYWHEEL HOUSING ASSY.

FLYWHEEL HOUSING ASSY.

| <u>NO.</u> | <u>PART NO.</u> | <u>ITEM</u> | <u>QTY.</u> | <u>REMARKS</u> |
|------------|-----------------|-----------------------|-------------|----------------|
| 1-5 | 5113410191 | FLYWHEEL HOUSING | 1 | |
| 11 | 9113430391 | COVER | 1 | |
| 12 | 9019006120 | BOLT | 6 | |
| 21 | 5113490380 | STIFFENER; RIGHT SIDE | 1 | |
| 22 | 5113490370 | STIFFENER; LEFT SIDE | 1 | |
| 23 | 9019110200 | BOLT | 2 | |
| 23-1 | 9019110180 | BOLT | 2 | |
| 31 | 9019310450 | BOLT | 4 | |
| 41 | 9019110350 | BOLT | 3 | |
| 41 | 9010560400 | BOLT | 1 | |
| 42 | 9091104100 | NUT | 2 | |
| 46 | 9091505100 | LOCKWASHER | 2 | |

ISUZU C240 OIL PAN ASSY.

OIL PAN ASSY.

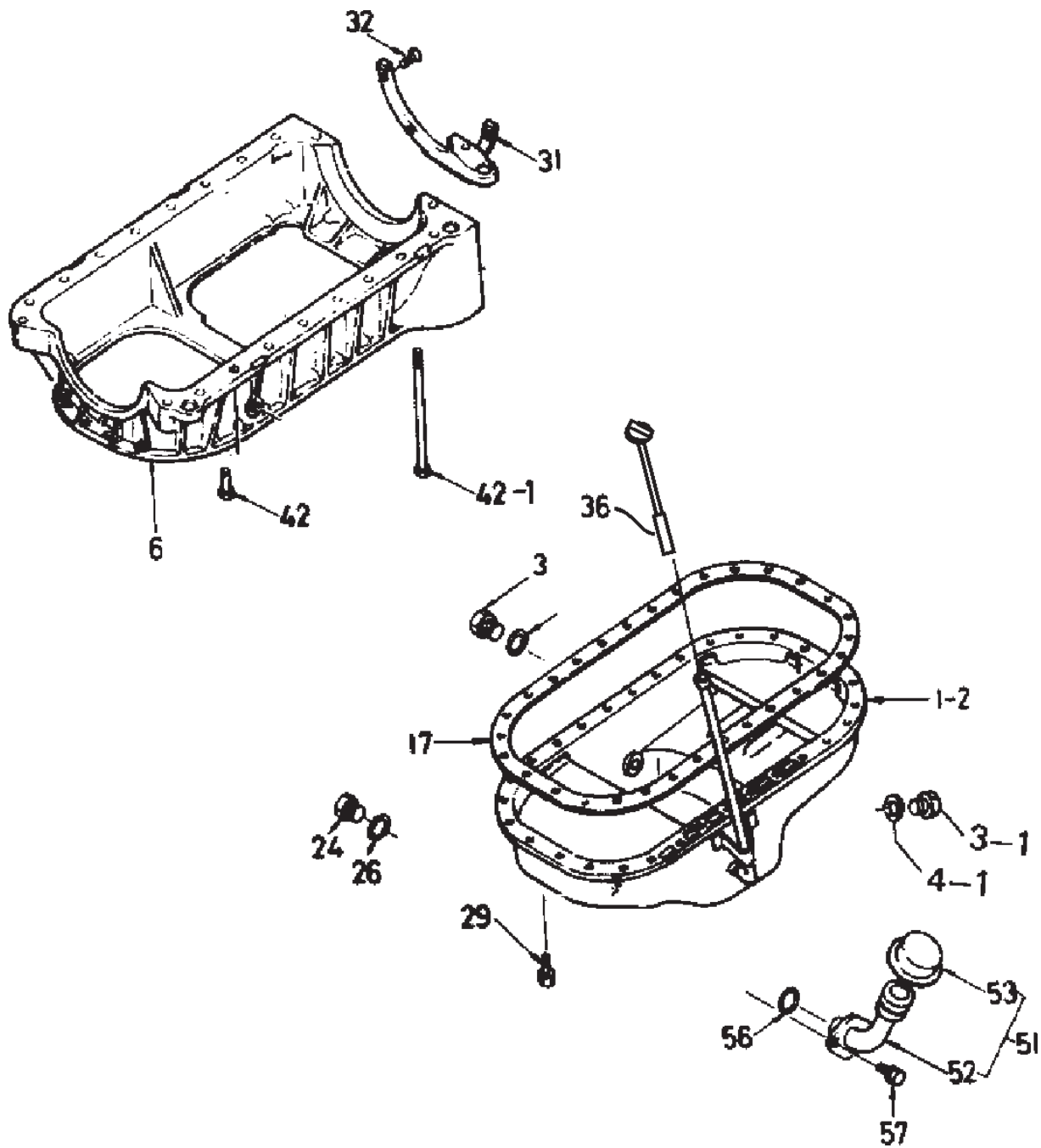

ISUZU C240 OIL PAN ASSY.

OIL PAN ASSY.

| <u>NO.</u> | <u>PART NO.</u> | <u>ITEM</u> | <u>QTY.</u> | <u>REMARKS</u> |
|------------|-----------------|----------------------|-------------|-----------------|
| 1-2 | 5113601832 | OIL PAN ASSY..... | 1 | INCL. ITEMS W/* |
| 3* | 5096050050 | OIL DRAIN PLUG, 3/8 | 1 | |
| 3-1 | 9992023200 | OIL DRAIN PLUG | 1 | |
| 4-1* | 9097205600 | O RING PACKING | 1 | |
| 6 | 9112150810 | CRANK CASE | 1 | |
| 17 | 5113670040 | OIL CASE PACKING | 1 | |
| 24 | 9992023160 | OIL THERMO PLUG | 1 | |
| 26 | 9095714160 | PLUG PACKING | 1 | |
| 29 | 9019106160 | BOLT | 30 | |
| 31 | 9112193160 | DISTRIBUTION PLATE | 1 | |
| 32 | 9030906160 | SCREW | 4 | |
| 36 | 9117606090 | OIL LEVEL GAUGE | 1 | |
| 42 | 9019008220 | BOLT | 16 | |
| 42-1 | 9019708450 | BOLT | 4 | |
| 51 | 5117400870 | OIL FILLER ASSY..... | 1 | INCL. ITEMS W/# |
| 52# | 5117410100 | OIL FILLER | 1 | |
| 53# | 5117500021 | OIL FILLER CAP | 1 | |
| 56 | 9099207080 | PACKING | 1 | |
| 57 | 9019008200 | BOLT | 2 | |

ISUZU C240 ---OIL PUMP ASSY.

OIL PUMP ASSY.

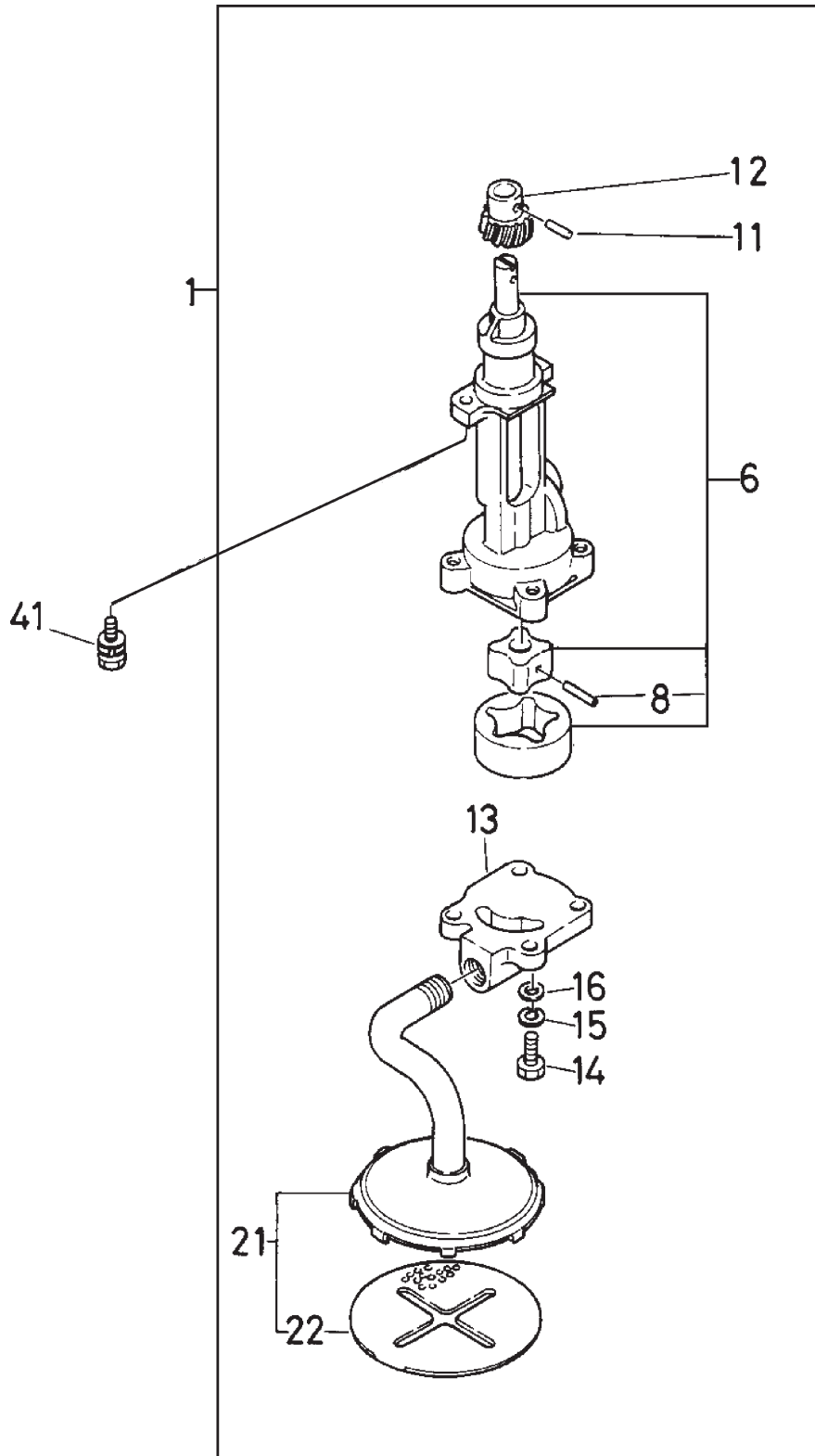

ISUZU C240 ---OIL PUMP ASSY.

OIL PUMP ASSY.

| <u>NO.</u> | <u>PART NO.</u> | <u>ITEM</u> | <u>QTY.</u> | <u>REMARKS</u> |
|------------|-----------------|-------------------------|-------------|-----------------------|
| 1 | 9131008010 | OIL PUMP ASSY. | 1 | INCL. ITEMS W/* |
| 6* | 5131200040 | ROTOR SET | 1 | INCL. ITEMS W/# |
| 8*# | 9131290170 | PIN | 1 | |
| 11*# | 9098780840 | PIN | 1 | |
| 12* | 9131280790 | PINION | 1 | |
| 13* | 9131130771 | COVER | 1 | |
| 14* | 9020408250 | BOLT | 4 | |
| 15* | 9091505080 | LOCKWASHER | 4 | |
| 16* | 9091505080 | LOCKWASHER | 4 | |
| 21* | 9131401200 | OIL STRAINER ASSY. | 1 | INCL. ITEM W/% |
| 22*% | 9131430100 | OIL STRAINER GAUZE | 1 | |
| 41 | 9019708250 | BOLT | 2 | |

ISUZU C240 --- CRANKSHAFT, BRIDGE AND FLYWHEEL ASSY.

CRANKSHAFT, BRIDGE AND FLYWHEEL ASSY.

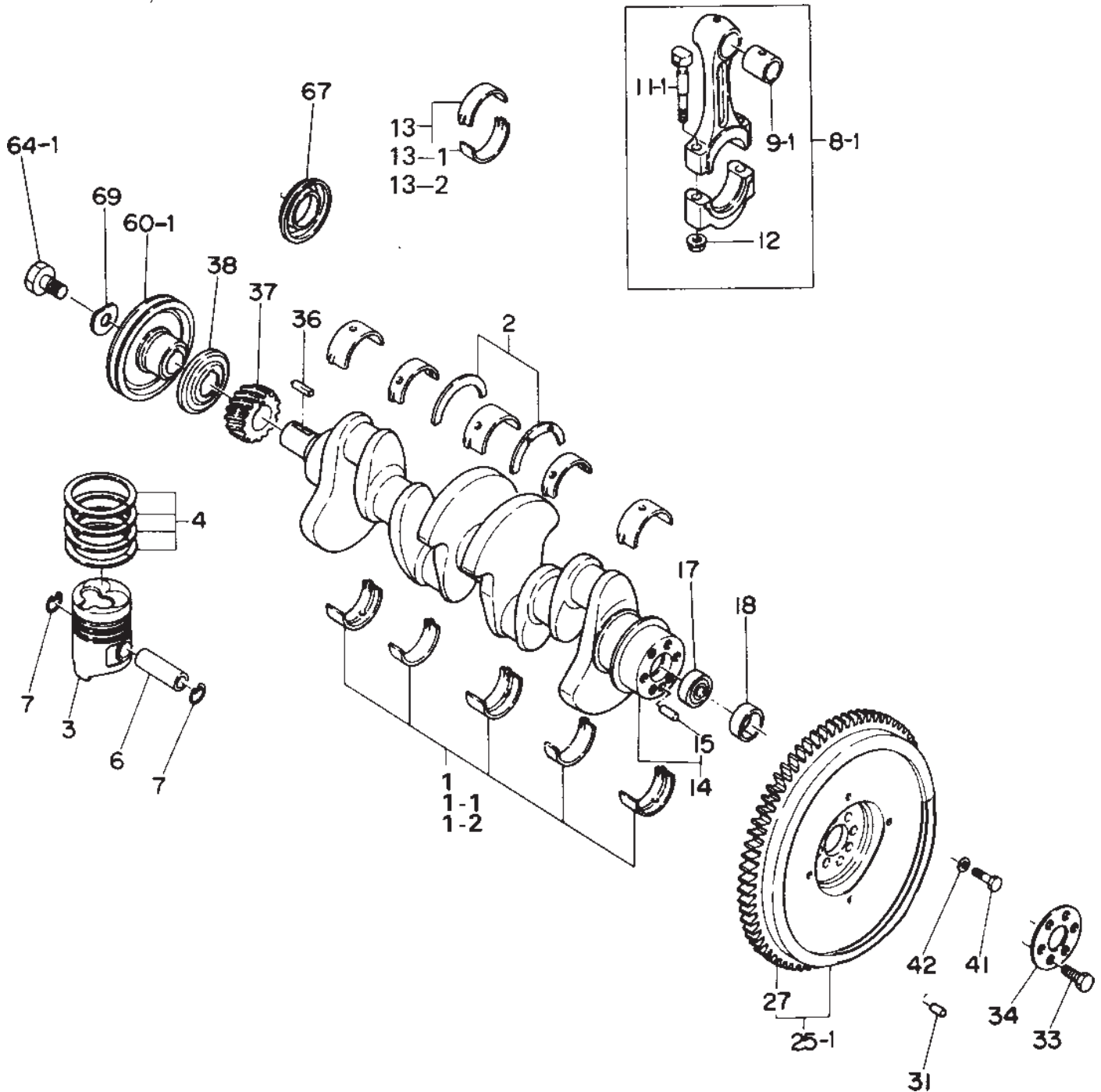

ISUZU C240 --- CRANKSHAFT, BRIDGE AND FLYWHEEL ASSY.

CRANKSHAFT, BRIDGE AND FLYWHEEL ASSY.

| <u>NO.</u> | <u>PART NO.</u> | <u>ITEM</u> | <u>QTY</u> | <u>REMARKS</u> |
|------------|-----------------|---------------------------------|------------|---------------------|
| 1 | 5115100211 | CRANK BEARING KIT;STD | 1 | |
| 1-1 | 5115300211 | CRANK BEARING KIT;-0.25 | 1 | |
| 1-2 | 5115400211 | CRANK BEARING KIT;-0.50 | 1 | |
| 2 | 9115810570 | THRUST BEARING | 2 | |
| 3 | 5121112020 | PISTON;STD | 4 | |
| 4 | 5121210070 | PISTON RING SET;STD | 4 | |
| 6 | 5122110090 | PISTON PIN | 4 | |
| 7 | 5095870010 | SNAP RING | 8 | |
| 8-1 | 5122300390 | CONNECTING ROD ASSY. | 4 | INCL. ITEMS W/@ |
| 9-1@ | 5122510050 | SMALL END BUSHING | 4 | |
| 11-1@ | 512350090 | BOLT | 8 | |
| 12@ | 5094090160 | NUT | 8 | |
| 13 | 8941422080 | CONN. ROD BEARING SET;STD | 4 | REPLACES 5122710050 |
| 13-1 | 8941631740 | BEARING SET;-0.25 | 4 | |
| 13-2 | 8941631750 | BEARING SET;-0.50 | 4 | |
| 14 | 8941396690 | CRANKSHAFT ASSY. | 1 | INCL. ITEM W/# |
| 15# | 9081612200 | STRAIGHT PIN | 1 | |
| 17 | 5098010010 | RADIAL BALL BEARING | 1 | |
| 25-1 | 5123301100 | FLYWHEEL ASSY. | 1 | INCL. ITEM W/% |
| 27% | 9123330361 | RING GEAR | 1 | Z=108 |
| 31 | 9098785320 | STRAIGHT PIN | 2 | |
| 33 | 5090001461 | BOLT | 6 | |
| 34 | 5123360100 | WASHER | 1 | |
| 36 | 9080307430 | FEATHER KEY | 1 | |
| 37 | 9125210420 | CRANKSHAFT GEAR | 1 | Z=21 |
| 38 | 9123620390 | THROWER | 1 | |
| 60-1 | 9123736051 | CRANKSHAFT PULLEY | 1 | |
| 64-1 | 9098026060 | BOLT | 1 | |
| 67 | 9123736060 | THROWER | 1 | |
| 69 | 9123790160 | WASHER | 1 | |

ISUZU C240 --- OIL AND FUEL FILTER ASSY.

OIL AND FUEL FILTER ASSY.

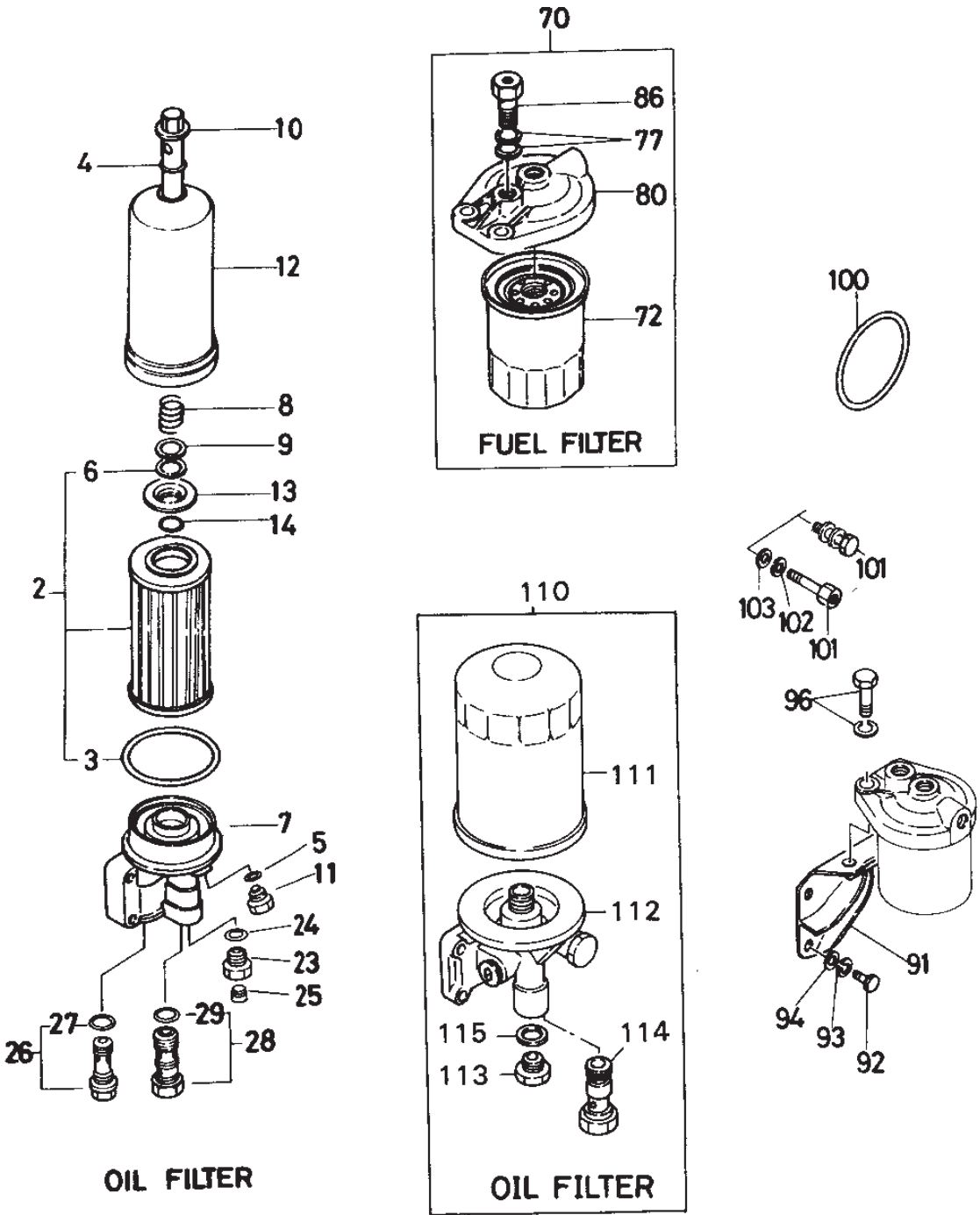

ISUZU C240 --- OIL AND FUEL FILTER ASSY.

OIL AND FUEL FILTER ASSY.

| <u>NO.</u> | <u>PART NO.</u> | <u>ITEM</u> | <u>QTY.</u> | <u>REMARKS</u> |
|------------|-----------------|------------------------------|-------------|---------------------|
| 2 | 9885131071 | OIL FILTER ELEMENT KIT | 1 | INCL. ITEMS W/* |
| 3* | 9132130350 | O RING PACKING COVER | 1 | |
| 4 | 9099211920 | CENTER PIPE PACKING | 1 | |
| 5-1 | 9099209780 | DRAIN PIPE PACKING | 1 | |
| 6* | 9099221100 | FELT RING | 1 | |
| 7 | 9132121240 | OIL FILTER COVER | 1 | |
| 8 | 9099410540 | COIL COMPRESSION SPRING | 1 | |
| 9 | 9132390330 | SPRING SEAT | 1 | |
| 10 | 9132316030 | CENTER PIPE | 1 | |
| 11 | 9098621170 | DRAIN PLUG | 1 | |
| 12 | 9132110950 | OIL FILTER BODY | 1 | |
| 13 | 9132390320 | ELEMENT HOLDER | 1 | |
| 14 | 9099522170 | SNAP RING | 1 | |
| 23 | 9132260130 | ADAPTER | 1 | |
| 24 | 9099208410 | PLUG PACKING | 1 | |
| 25 | 9098640150 | SCREW PLUG | 1 | |
| 26 | 5132600080 | SAFETY VALVE ASSY. | 1 | INCL. ITEM W/% |
| 27% | 1096231630 | O RING PACKING | 1 | |
| 28 | 5131600030 | RELIEF VALVE ASSY. | 1 | INCL. ITEM W/# |
| 29# | 9099209750 | RELIEF VALE PACKING | 1 | |
| 70 | 8941434770 | FUEL CART. FILTER ASSY. | 1 | INCL. ITEMS W/\$ |
| 72\$ | 8941434790 | FUEL ELEMENT | 1 | |
| 77\$ | 9095720140 | OVERFLOW VALVE PACKING | 2 | |
| 80\$ | 5132120750 | FUEL FILTER COVER | 1 | |
| 86\$ | 9132600561 | OVERFLOW VALVE ASSY. | 1 | |
| 91 | 9197518010 | FUEL FILTER BRACKET | 1 | |
| 92 | 9020608180 | BOLT | 2 | |
| 93 | 9091506080 | LOCKWASHER | 2 | REPLACES 9091508080 |
| 94 | 9091645080 | PLAIN WASHER | 2 | |
| 96 | 9019110320 | BOLT | 2 | |
| 100 | 9132190570 | OIL FILTER PACKING | 1 | |
| 101-1 | 9019008350 | BOLT | 4 | |
| 110 | 8941208540 | OIL FILTER ASSY. | 1 | INCL. ITEMS W/@ |
| 111@ | 8941564550 | OIL FILTER CARTRIDGE | 1 | |
| 112@ | 8941564540 | OIL FILTER BODY | 1 | |
| 113@ | 9132260090 | ADAPTER | 1 | |
| 114@ | 5131600030 | RELIEF VALVE ASSY. | 1 | |
| 115@ | 9099206200 | PACKING ADAPTER | 1 | |

OIL PIPE ASSY.

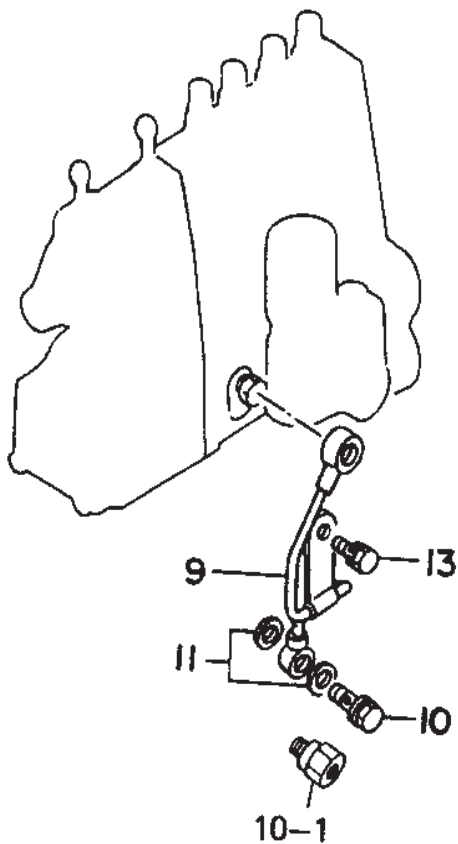
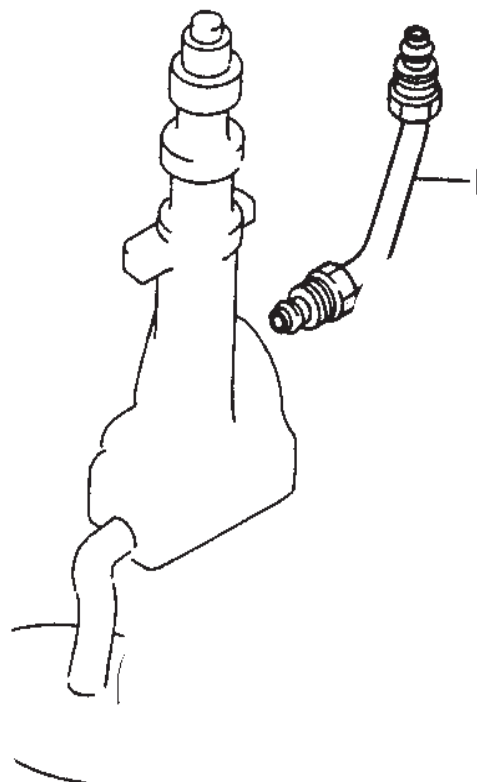
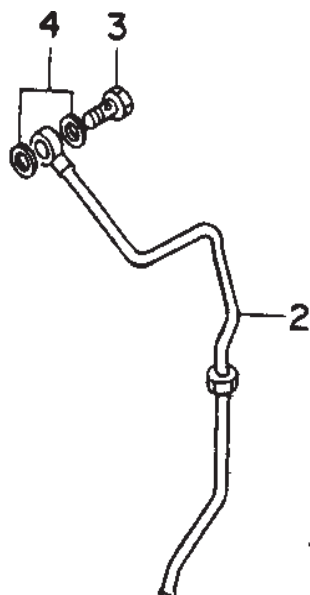

OIL PIPE ASSY.

| <u>NO.</u> | <u>PART NO.</u> | <u>ITEM</u> | <u>QTY.</u> | <u>REMARKS</u> |
|-------------------|------------------------|----------------------|--------------------|-----------------------|
| 1 | 9133119810 | OIL PUMP ASSY. | 1 | |
| 2 | 5133111141 | ROCKER OIL FEED PIPE | 1 | |
| 3 | 9099061051 | BOLT | 1 | |
| 4 | 9099209000 | PACKING | 2 | |
| 9 | 5133111740 | OIL INJECTION PIPE | 1 | |
| 10 | 5096750220 | ADAPTER | 1 | |
| 11 | 9095720080 | PACKING | 2 | |
| 13 | 901906120 | BOLT | 1 | |

ISUZU C240 --- WATER PUMP AND FAN ASSY.

WATER PUMP AND FAN ASSY.

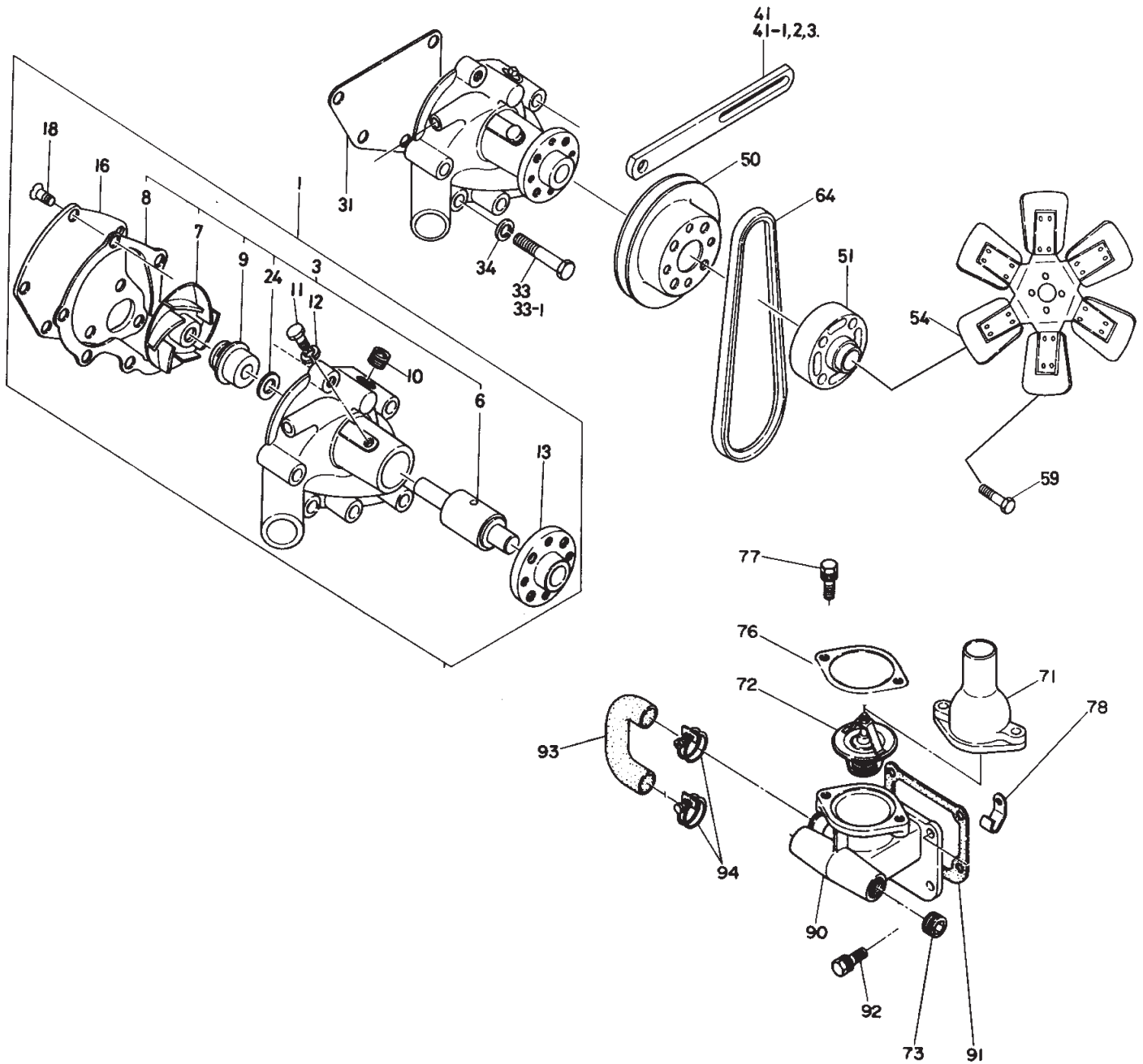

ISUZU C240 --- WATER PUMP AND FAN ASSY.

WATER PUMP AND FAN ASSY.

| <u>NO.</u> | <u>PART NO.</u> | <u>ITEM</u> | <u>QTY.</u> | <u>REMARKS</u> |
|------------|-----------------|-----------------------------|-------------|-----------------|
| 1 | 5136101673 | WATER PUMP ASSY. | 1 | INCL. ITEMS W/* |
| 3* | 5878101391 | WATER PUMP REPAIR KIT | 1 | INCL. ITEMS W.# |
| 6*# | 5136310080 | BEARING UNIT | 1 | |
| 7*# | 9136210760 | IMPELLER | 1 | |
| 8*# | 9136136070 | PACKING | 1 | |
| 9*# | 8942366870 | SEAL UNIT ASSY. | 1 | |
| 10*# | 5096050050 | SCREW HEATER PLUG | 1 | |
| 11*# | 5098140010 | SCREW | 1 | |
| 12*# | 9091505080 | LOCKWASHER | 1 | |
| 13*# | 5136420640 | FAN CENTER | 1 | |
| 16*# | 9136120530 | WATER PUMP COVER | 1 | |
| 18*# | 9030408160 | SCREW | 1 | |
| 24*# | 9136390010 | BRIDGE UNIT THROWER | 1 | |
| 31 | 9136140430 | PACKING | 1 | |
| 33 | 5090000890 | BOLT | 2 | |
| 33-1 | 5090000880 | BOLT | 4 | |
| 41 | 5136750390 | ADJUSTING FAN BELT PLATE | 1 | |
| 50 | 9136416160 | FAN PULLEY | 1 | |
| 51 | 9136420770 | FAN SPACER | 1 | |
| 54 | 9136608090 | FAN ASSY. | 1 | |
| 59 | 9019108450 | BOLT | 4 | |
| 64 | 5136710400 | COOLING FAN BELT | 1 | |
| 71 | 9137130380 | OUTLET PIPE | 1 | |
| 72 | 5137700221 | THERMOSTAT | 1 | |
| 73 | 5096050050 | HEATER PLUG | 1 | |
| 76 | 5096370130 | PACKING | 1 | |
| 77 | 9019708300 | BOLT | 2 | |
| 78 | 9099168190 | CLIP | 1 | |
| 90 | 9137168042 | THERMOSTAT HOUSING | 1 | |
| 91 | 5137430050 | HOUSING PACKING | 1 | |
| 92 | 9019708200 | BOLT | 2 | |
| 92 | 9019108220 | BOLT | 2 | |
| 93 | 9137211322 | RUBBER BYPASS HOSE | 1 | |
| 94 | 9099156441 | HOSE CLIP | 2 | |

ISUZU C240 --- INTAKE AND EXHAUST MANIFOLD ASSY.

INTAKE AND EXHAUST MAINIFOLD ASSY.

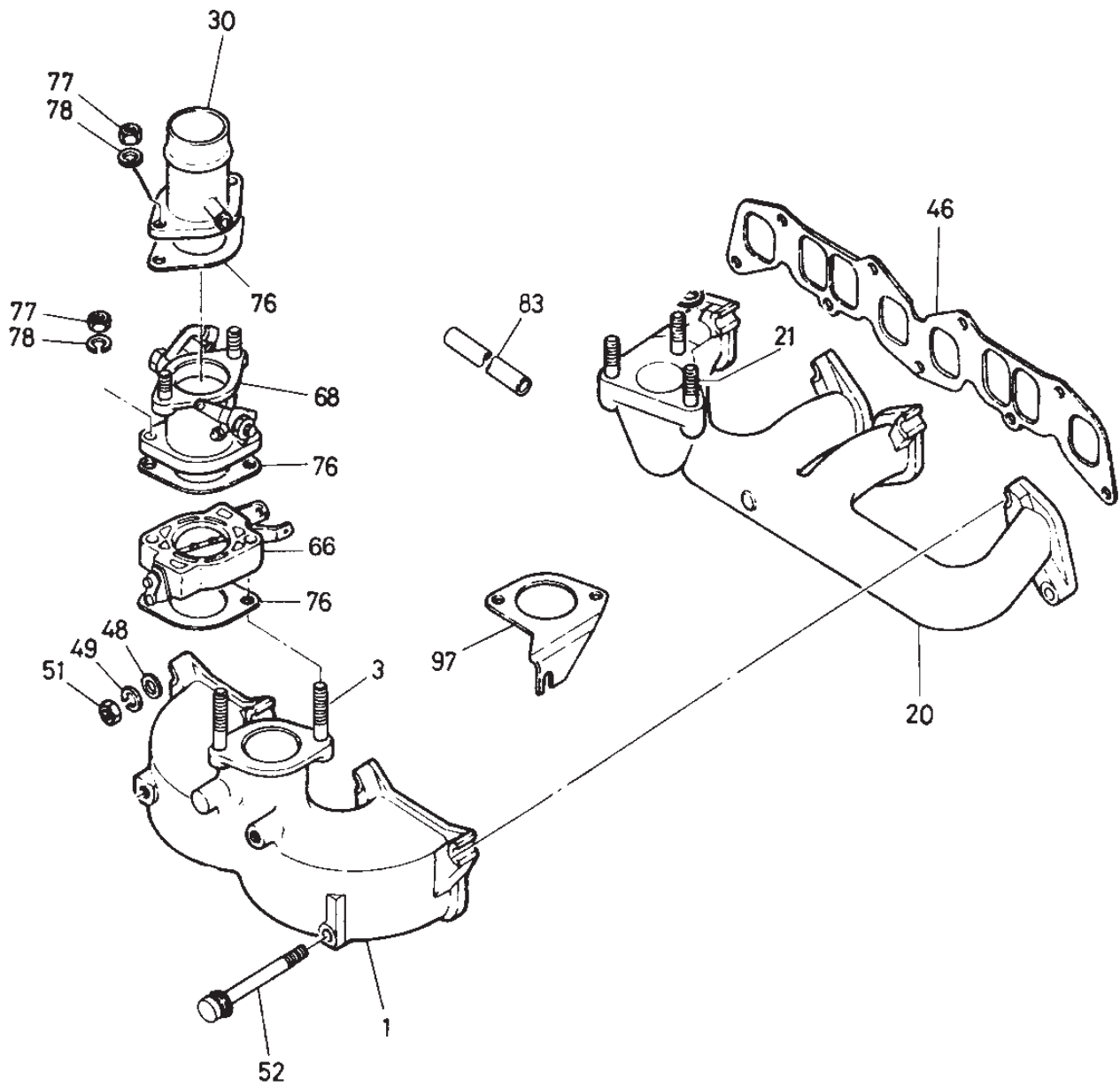

ISUZU C240 --- INTAKE AND EXHAUST MANIFOLD ASSY.

INTAKE AND EXHAUST MANIFOLD ASSY.

| <u>NO.</u> | <u>PART NO.</u> | <u>ITEM</u> | <u>QTY.</u> | <u>REMARKS</u> |
|------------|-----------------|------------------------|-------------|----------------|
| 1 | 9141126954 | INLET MANIFOLD | 1 | |
| 3 | 9041108500 | INTAKE STUD | 2 | |
| 20 | 9141416142 | EXHAUST MANIFOLD | 1 | |
| 21 | 5093020020 | EXHAUST STUD | 1 | |
| 30 | 5141111290 | INLET PIPE | 2 | |
| 46 | 5141460180 | GASKET | 1 | |
| 48 | 9091646080 | PLAIN WASHER | 7 | |
| 49 | 9091505080 | LOCK WASHER | 7 | |
| 51 | 9091104080 | NUT | 7 | |
| 52 | 5090000870 | BOLT | 2 | |
| 66 | 5143101961 | INTAKE SHUTTER ASSY. | 1 | |
| 76 | 5096370150 | THROTTLE VALVE PACKING | 3 | |
| 77 | 9091104080 | NUT | 3 | |
| 78 | 9091505080 | LOCK WASHER | 2 | |
| 83 | 5093600530 | HOSE | 1 | |
| 97 | 5143340780 | WIRE CONTROL BRACKET | 1 | |

ISUZU C240 --- AIR CLEANER ASSY.

AIR CLEANER ASSY.

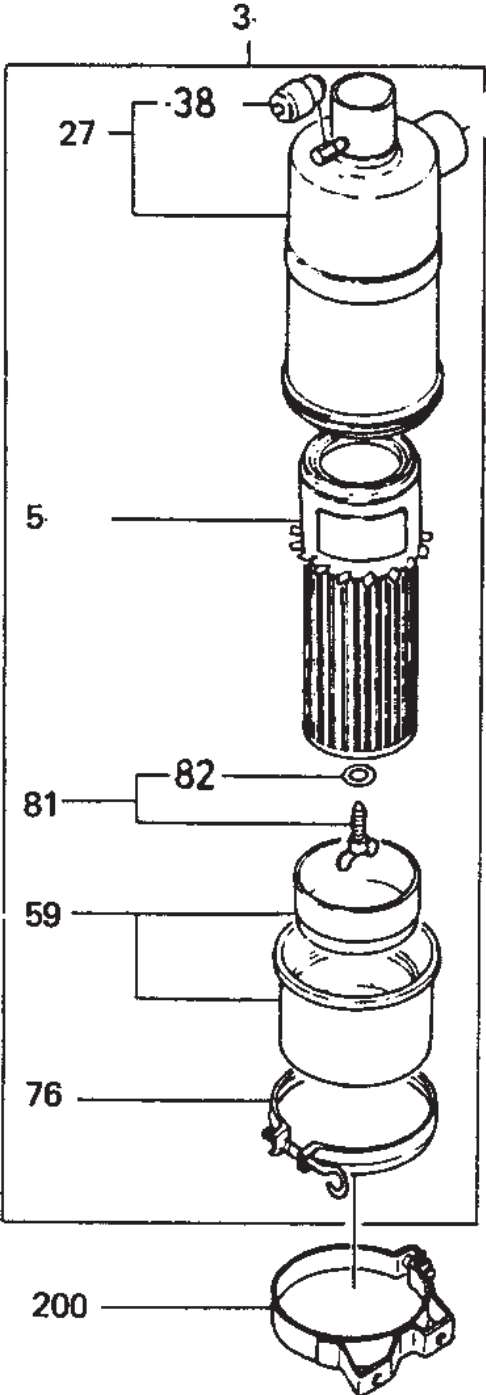

ISUZU C240 --- AIR CLEANER ASSY.

AIR CLEANER ASSY.

| <u>NO.</u> | <u>PART NO.</u> | <u>ITEM</u> | <u>QTY.</u> | <u>REMARKS</u> |
|------------|-----------------|----------------------------|-------------|-----------------|
| 3 | 5142102130 | AIR CLEANER ASSY..... | 1 | INCL. ITEMS W/* |
| 5* | 5142150140 | ELEMENT | 1 | |
| 27* | 5142110670 | COVER | 1 | |
| 38* | 9142191410 | INDICATOR | 1 | |
| 59* | 5142120560 | DUST W/BAFFLE PAN | 1 | |
| 76* | 5142170040 | CLAMP | 1 | |
| 81* | 9142170620 | BOLT W/GASKET WASHER | 1 | INCL. ITEMS W/# |
| 82*# | 9142191770 | GASKET WASHER | 3 | |
| 200 | 9142176020 | BAND ASSY. W/BOLT | 2 | |

ISUZU C240 --- ENGINE FOOT ASSY.

ENGINE FOOT ASSY.

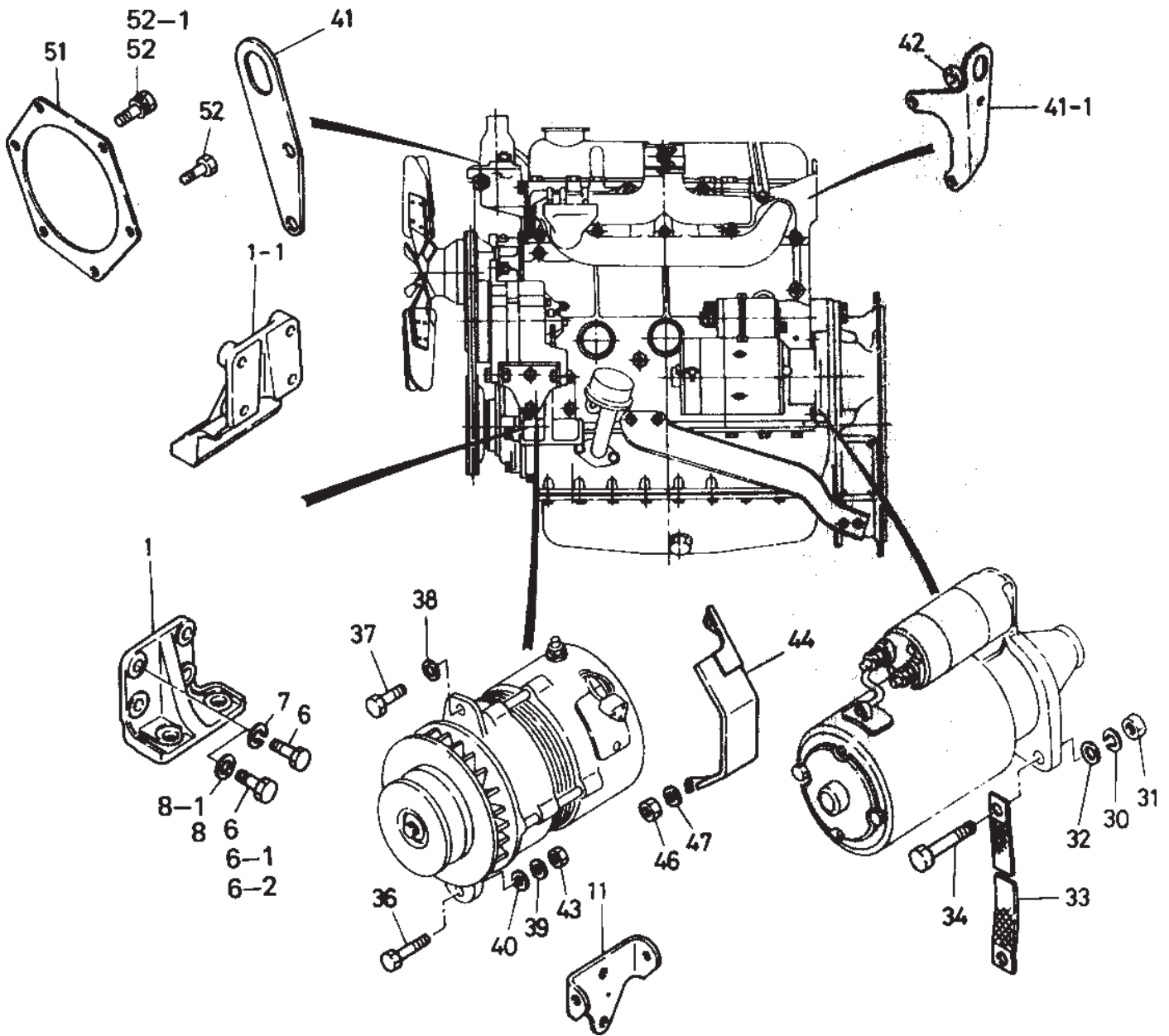

ISUZU C240 --- ENGINE FOOT ASSY.

ENGINE FOOT ASSY.

| <u>NO.</u> | <u>PART NO.</u> | <u>ITEM</u> | <u>QTY.</u> | <u>REMARKS</u> |
|------------|-----------------|-------------------------|-------------|----------------|
| 1 | 9117712070 | ENGINE FOOT, RIGHT SIDE | 1 | |
| 1-1 | 5117710501 | ENGINE FOOT, LEFT SIDE | 1 | |
| 6 | 9029510250 | FOOT BOLT, RIGHT SIDE | 4 | |
| 6-1 | 9029510250 | BOLT FOOT, LEFT SIDE | 1 | |
| 6-2 | 9029560400 | BOLT FOOT, LEFT SIDE | 3 | |
| 8 | 9098518660 | PLAIN WASHER | 8 | |
| 11 | 5197110010 | ALTERNATOR BRACKET | 1 | |
| 30 | 9091505080 | LOCKWASHER | 1 | |
| 31 | 9091114080 | NUT | 1 | |
| 32 | 9091605120 | PLAIN WASHER | 1 | |
| 33 | 9829315110 | CABLE ASSY. | 1 | |
| 34 | 9019312450 | BOLT | 2 | |
| 36 | 9010558320 | BOLT | 2 | |
| 37 | 9019108400 | BOLT | 1 | |
| 38 | 9091647080 | PLAIN WASHER | 1 | |
| 39 | 9091505080 | LOCKWASHER | 2 | |
| 40 | 9091605080 | PLAIN WASHER | 2 | |
| 41 | 9117770750 | FRONT LIFTING HANGER | 1 | |
| 41-1 | 9117771360 | REAR LIFTING HANGER | 1 | |
| 42 | 9141491730 | REAR HANGER PIECE | 2 | |
| 43 | 9091105080 | NUT | 2 | |
| 44 | 5197190060 | ALTERNATOR FAN COVER | 1 | |
| 46 | 9091104080 | NUT | 1 | |
| 47 | 9091505080 | LOCKWASHER | 1 | |
| 51 | 5113190570 | FRONT PLATE PACKING | 1 | |
| 52 | 8942059870 | BOLT | 2 | |
| 52-1 | 9019108320 | BOLT | 4 | |

ISUZU C240 --- INJECTION PUMP ASSY.

INJECTION PUMP ASSY.

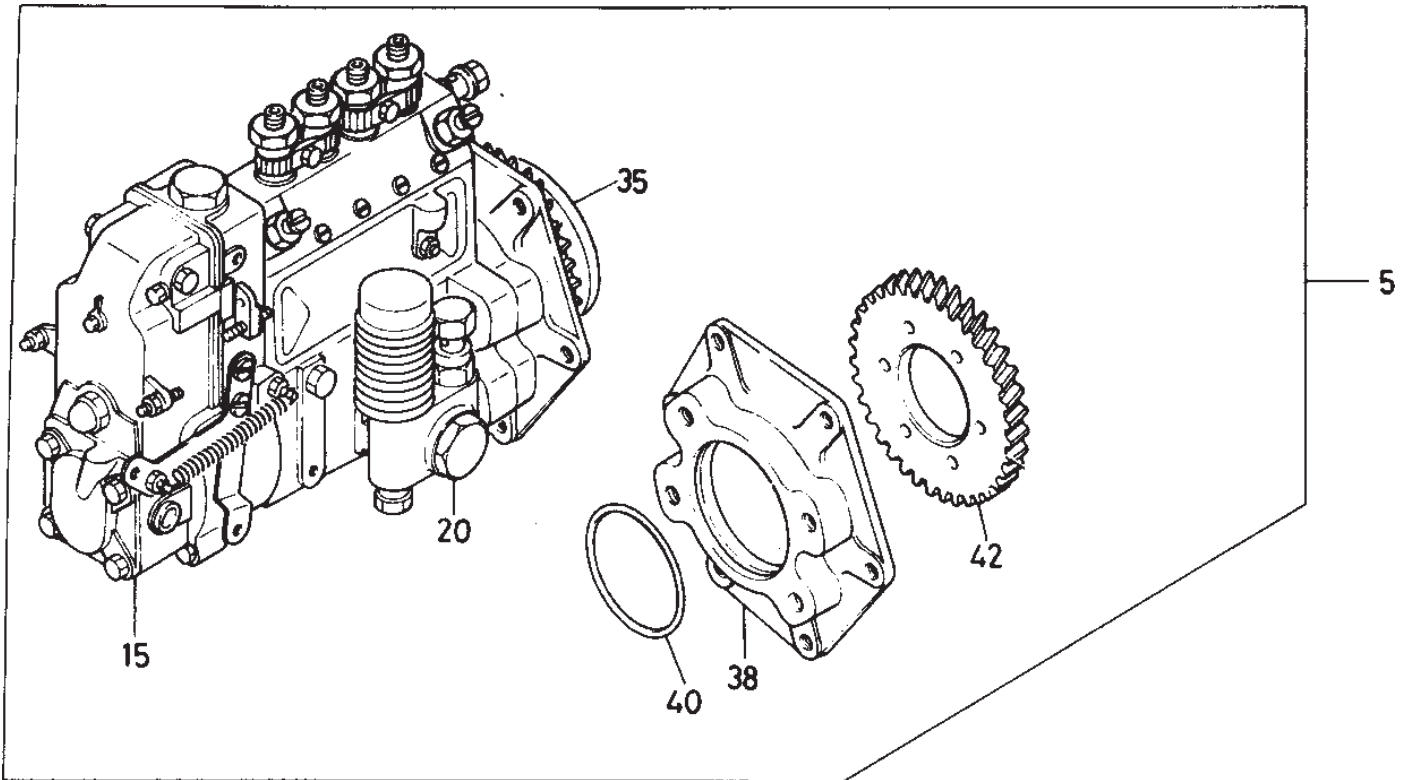

ISUZU C240 --- INJECTION PUMP ASSY.

INJECTION PUMP ASSY.

| <u>NO.</u> | <u>PART NO.</u> | <u>ITEM</u> | <u>QTY.</u> | <u>REMARKS</u> |
|------------|-----------------|---------------------------|-------------|--|
| 5 | 8943864440 | INJECTION PUMP ASSY. | 1 | REPLACES 5156010252 INCL. ITEMS W/* |
| 15* | 5157201400 | GOVERNOR ASSY. | 1 | |
| 20* | 8941415340 | FEED PUMP ASSY. | 1 | |
| 35* | 5157400720 | AUTOMATIC TIMER | 1 | |
| 38* | 9197510790 | INJ. PUMP SPACER BRACKET | 1 | |
| 40* | 9099205760 | O RING PACKING | 1 | |
| 42* | 5125240660 | INJ. PUMP GEAR | 1 | |

ELECTRICAL PARTS

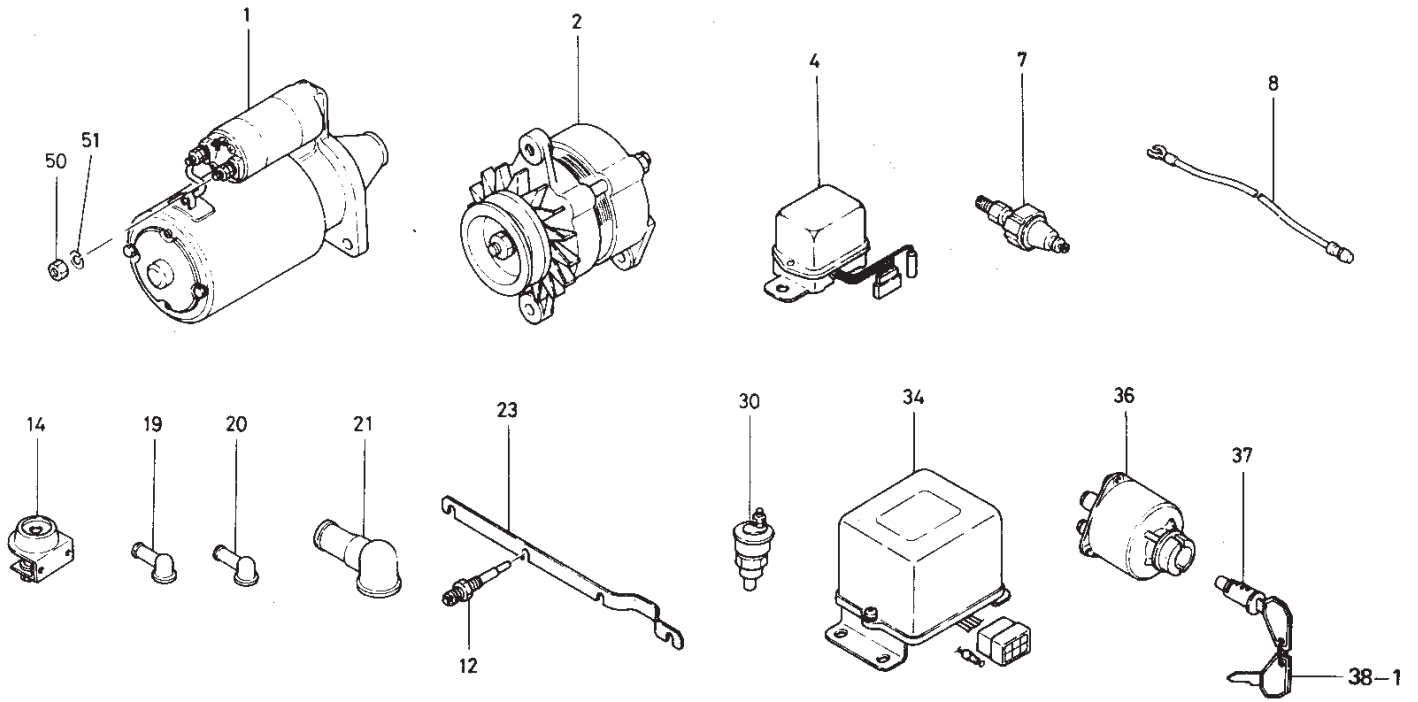

ISUZU C240 --- ELECTRICAL PARTS

ELECTRICAL PARTS

| <u>NO.</u> | <u>PART NO.</u> | <u>ITEM</u> | <u>QTY.</u> | <u>REMARKS</u> |
|------------|-----------------|------------------|-------------|-----------------|
| 1 | 5811000801 | STARTER | 1 | |
| 2 | 5812003410 | ALTERNATOR | 1 | UP TO OCT. 1992 |
| | 9822007640 | ALTERNATOR | 1 | OCT. 1992~ |
| 4 | 9822531070 | REGULATOR | 1 | |
| 8 | 9829317430 | CABLE ASSY. | 1 | |
| 12 | 9825119780 | GLOW PLUG | 4 | |
| 14 | 9825301090 | CONTROL | 1 | |
| 19 | 9829513240 | INSULATOR CAP | 2 | |
| 20 | 9829513250 | INSULATOR CAP | 2 | |
| 21 | 9829513320 | CABLE CAP | 1 | |
| 23 | 9197326100 | CONNECTOR | 1 | |
| 30 | 5824500140 | SWITCH | 1 | |
| 34 | 5825500190 | EMERGENCY RELAY | 1 | |
| 36 | 1823100080 | STARTER SWITCH | 1 | |
| 38-1 | 1823170070 | KEY | 1 | |
| 50 | 9091114080 | NUT | 1 | |
| 51 | 9091505080 | LOCKWASHER | 1 | |

ACCESSORIES

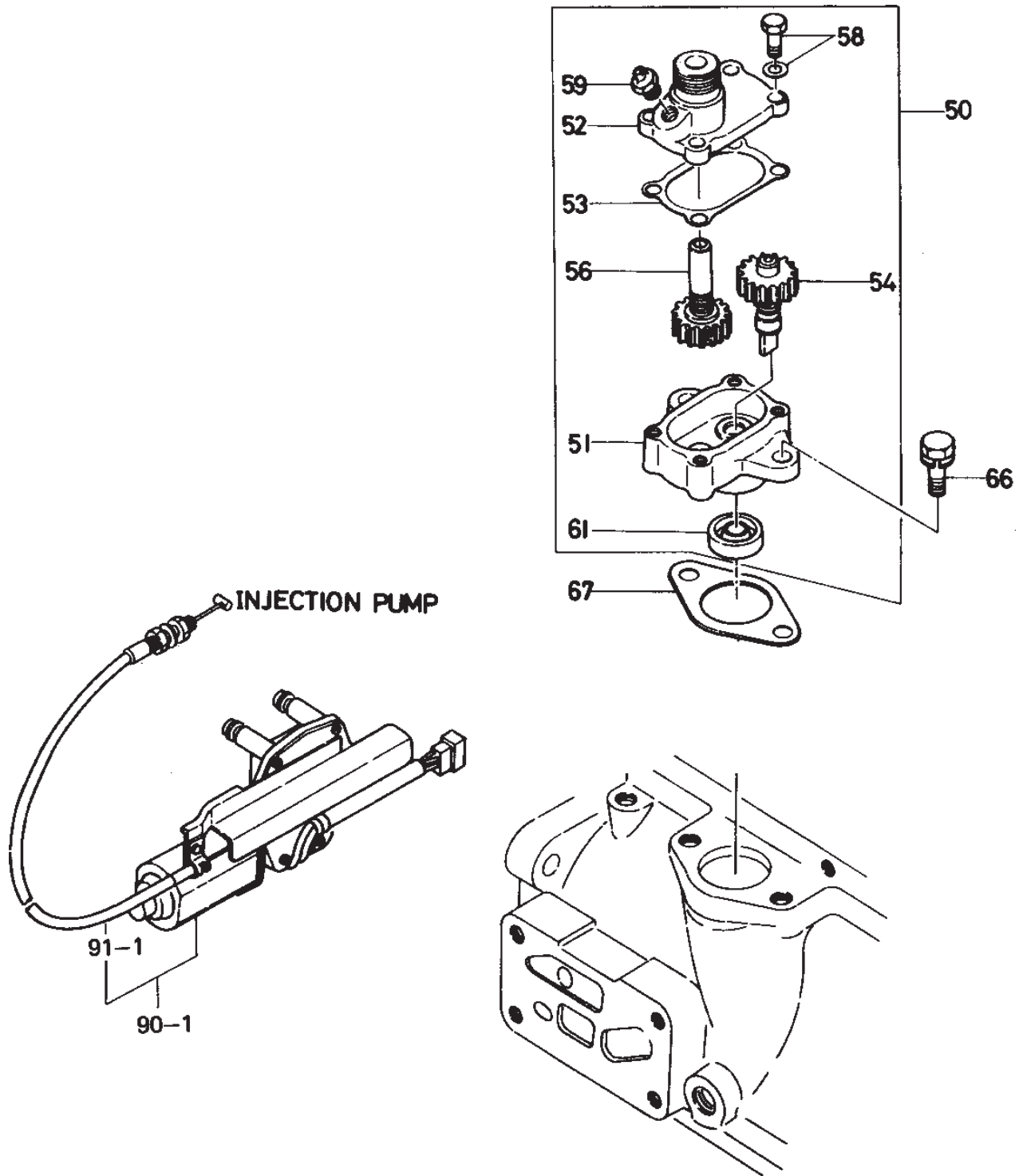

ISUZU C240 --- ACCESSORIES

ACCESSORIES

| <u>NO.</u> | <u>PART NO.</u> | <u>ITEM</u> | <u>QTY.</u> | <u>REMARKS</u> |
|------------|-----------------|------------------|-------------|-----------------------|
| 50 | 5193100060 | DRIVE ASSY. | 1 | INCL. ITEMS W/* |
| 51* | 9193110240 | CASE | 1 | |
| 52* | 9193110200 | COVER | 1 | |
| 53* | 9193120060 | PACKING | 1 | |
| 54* | 9193160270 | GEAR | 1 | |
| 56* | 9193160170 | GEAR | 1 | |
| 58* | 9019006160 | BOLT | 4 | |
| 59* | 9090310100 | NIPPLE | 1 | |
| 61* | 9099243550 | OIL SEAL | 1 | |
| 66 | 9019008220 | BOLT | 2 | |
| 67 | 9099211070 | PACKING | 1 | |
| 91 | 5819000020 | STOPPER ASSY. | 1 | |
| 91-1 | 5828480360 | CABLE ASSY. | 1 | |

ISUZU C240 ---INJECTION PUMP COMP. ASSY.

INJECTION PUMP COMP. ASSY.

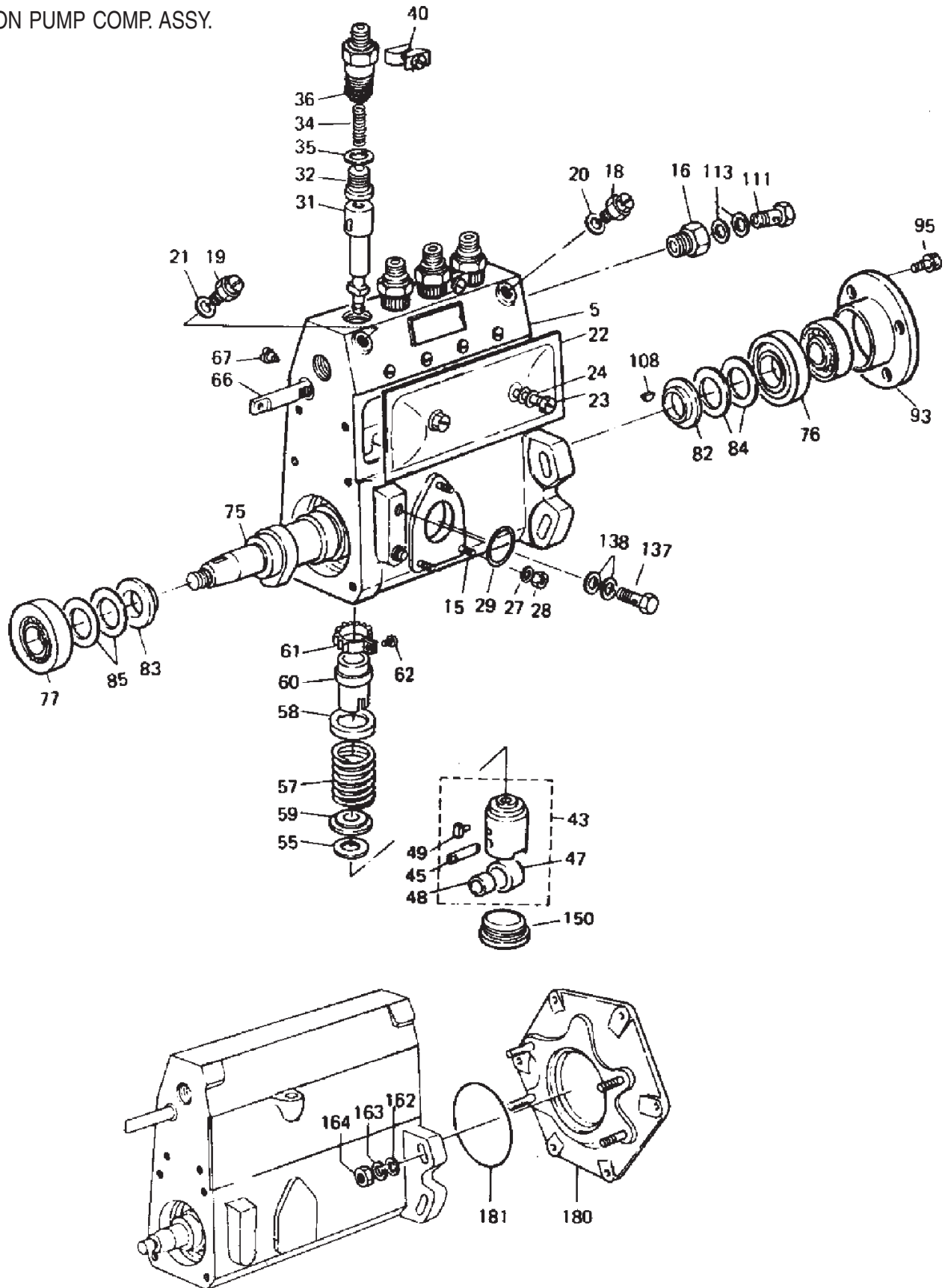

ISUZU C240 --- INJECTION PUMP COMP. ASSY.

INJECTION PUMP COMP. ASSY.

| <u>NO.</u> | <u>PART NO.</u> | <u>ITEM</u> | <u>QTY.</u> | <u>REMARKS</u> |
|------------|-----------------|-----------------------|-------------|-----------------|
| 5 | 5156110460 | HOUSING ASSY. | 1 | INCL. ITEMS W/* |
| 15* | 9812151150 | STUD | 3 | |
| 16* | 9812350170 | ADAPTER | 1 | |
| 18* | 1156190240 | BOLT | 2 | |
| 20* | 1156390080 | GASKET | 1 | |
| 21* | 1156390080 | GASKET | 1 | |
| 22* | 5156120080 | COVER | 1 | |
| 23* | 1156190030 | SCREW | 2 | |
| 24* | 9812151440 | GASKET | 2 | |
| 27* | 9091505060 | LOCKWASHER | 3 | |
| 28* | 9091104060 | NUT | 3 | |
| 29* | 1096230130 | PACKING | 1 | |
| 31* | 5156310090 | PLUNGER ASSY. | 4 | |
| 32* | 9812411030 | DELIVERY VALVE | 4 | |
| 34* | 5156430020 | DELIVERY VALVE SPRING | 4 | |
| 35* | 9812450140 | GASKET | 4 | |
| 36* | 5156440050 | HOLDER | 4 | |
| 40* | 5156490160 | PLATE ASSY. | 2 | |
| 43* | 9812212230 | TAPPET ASSY. | 4 | INCL. ITEMS W/# |
| 45*# | 9812212200 | PIN TAPPET | 4 | |
| 47*# | 1156220030 | TAPPET ROLLER | 4 | |
| 48*# | 1156290010 | TAPPET BUSHING | 4 | |
| 49*# | 5156190410 | TAPPET GUIDE | 4 | |
| 55* | 5156190340 | TAPPET SHIM | A/R | T=0.30 |
| 55-1* | 5156190350 | TAPPET SHIM | A/R | T=0.40 |
| 55-2* | 5156190360 | TAPPET SHIM | A/R | T=0.50 |
| 55-3* | 5156190010 | TAPPET SHIM | A/R | T=0.60 |
| 55-4* | 5156190020 | TAPPET SHIM | A/R | T=0.70 |
| 55-5* | 5156190030 | TAPPET SHIM | A/R | T=0.80 |
| 55-6* | 5156190040 | TAPPET SHIM | A/R | T=0.90 |
| 55-7* | 5156190050 | TAPPET SHIM | A/R | T=1.00 |
| 55-8* | 5156190070 | TAPPET SHIM | A/R | T=1.10 |
| 55-9* | 5156190080 | TAPPET SHIM | A/R | T=1.20 |
| 55-10* | 5156190090 | TAPPET SHIM | A/R | T=1.30 |
| 55-11* | 5156190100 | TAPPET SHIM | A/R | T=1.40 |
| 55-12* | 5156190110 | TAPPET SHIM | A/R | T=0.55 |
| 55-13* | 5156190120 | TAPPET SHIM | A/R | T=0.65 |
| 55-14* | 5156190130 | TAPPET SHIM | A/R | T=0.75 |
| 55-15* | 5156190150 | TAPPET SHIM | A/R | T=0.85 |
| 55-16* | 9812350420 | TAPPET SHIM | A/R | T=0.95 |
| 55-17* | 9812350430 | TAPPET SHIM | A/R | T=1.05 |
| 55-18* | 9812350440 | TAPPET SHIM | A/R | T=1.15 |
| 55-19* | 9812350450 | TAPPET SHIM | A/R | T=1.25 |
| 55-20* | 5156190250 | TAPPET SHIM | A/R | T=0.25 |

ISUZU C240 --- INJECTION PUMP COMP. ASSY.

INJECTION PUMP COMP. ASSY.

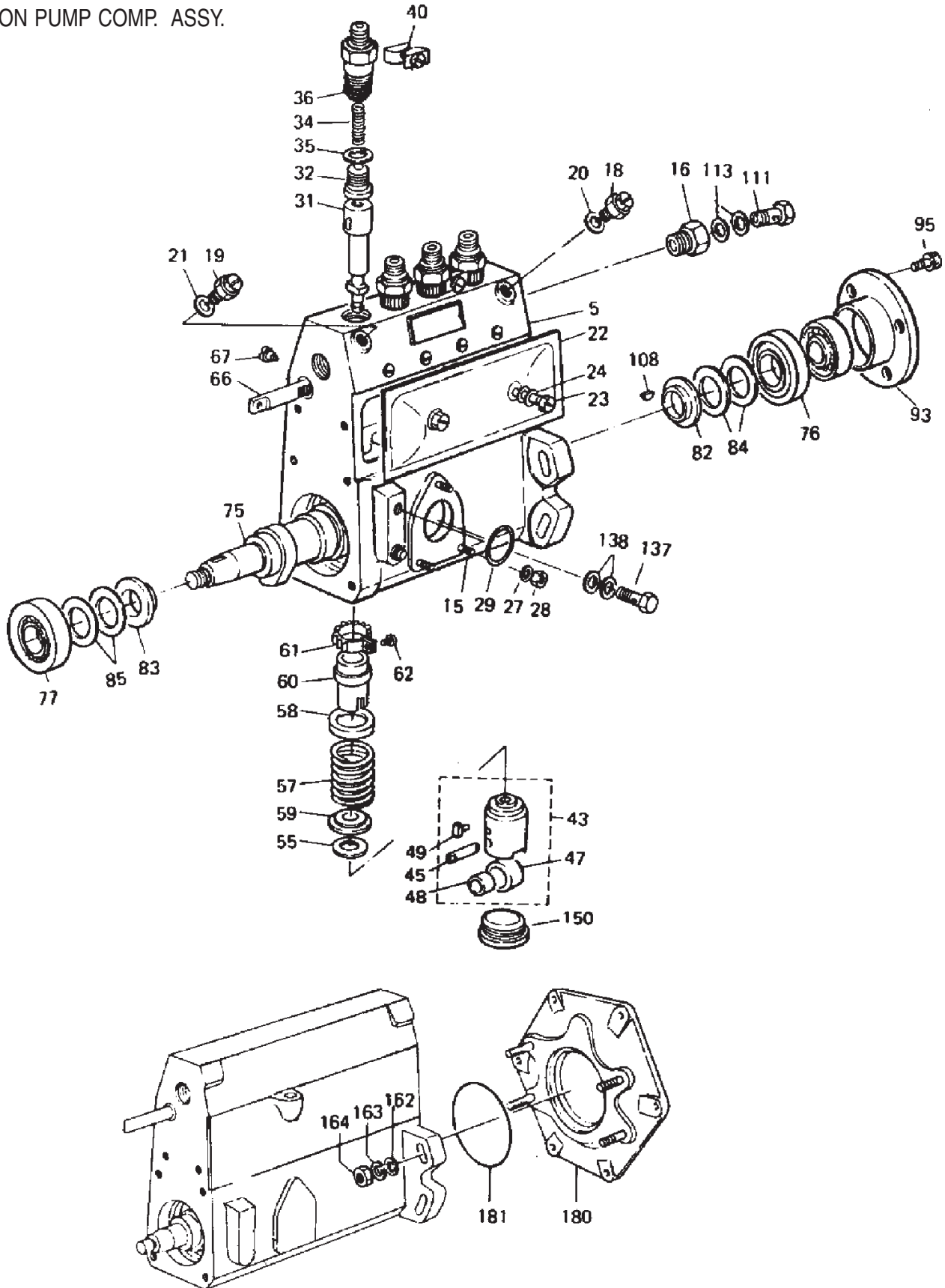

ISUZU C240 --- INJECTION PUMP COMP. ASSY.

INJECTION PUMP COMP. ASSY.

| <u>NO.</u> | <u>PART NO.</u> | <u>ITEM</u> | <u>QTY.</u> | <u>REMARKS</u> |
|------------|-----------------|-------------------------|-------------|----------------|
| 55-21* | 5156190260 | TAPPET SHIM | A/R | T=0.26 |
| 55-22* | 5156190270 | TAPPET SHIM | A/R | T=0.35 |
| 55-23* | 5156190370 | TAPPET SHIM | A/R | T=0.45 |
| 55-24* | 5156191060 | TAPPET SHIM | A/R | T=1.50 |
| 55-25* | 5156191070 | TAPPET SHIM | A/R | T=1.60 |
| 55-26* | 5156191080 | TAPPET SHIM | A/R | T=1.35 |
| 55-27* | 5156191090 | TAPPET SHIM | A/R | T=1.45 |
| 55-28* | 5156191100 | TAPPET SHIM | A/R | T=1.55 |
| 57* | 9812314070 | PLUNGER SPRING | 4 | |
| 58* | 9812350150 | PLUNGER SEAT | 4 | |
| 59* | 9812350210 | PLUNGER SEAT | 4 | |
| 60* | 9812250580 | SLEEVE | 4 | |
| 61* | 9812250570 | PINION | 4 | |
| 62* | 9812350030 | SCREW | 4 | |
| 66* | 5156370020 | CONTROL RACK | 1 | |
| 67* | 1156390030 | SCREW | 1 | |
| 75* | 5156210170 | CAM SHAFT | 1 | |
| 73* | 9812232010 | BALL BEARING, CAMSHAFT | 1 | |
| 76-2* | 9000906770 | BALL BEARING, CAMSHAFT | 1 | |
| 77* | 9812232010 | BALL BEARING, GOV. SIDE | 1 | |
| 77-2* | 9000906770 | BALL BEARING, GOV. SIDE | 1 | |
| 82* | 9812250470 | CAMSHAFT RING | 1 | |
| 83* | 9812250470 | CAM RING, GOV. SIDE | 1 | |
| 84* | 5156290150 | CAMSHAFT SHIM | A/R | T=0.10 |
| 84-1* | 5156290160 | CAMSHAFT SHIM | A/R | T=0.12 |
| 84-2* | 5156290170 | CAMSHAFT SHIM | A/R | T=0.14 |
| 84-3* | 5156290180 | CAMSHAFT SHIM | A/R | T=0.16 |
| 84-4* | 5156290190 | CAMSHAFT SHIM | A/R | T=0.18 |
| 84-5* | 5156290200 | CAMSHAFT SHIM | A/R | T=0.50 |
| 84-6* | 5156190380 | CAMSHAFT SHIM | A/R | T=1.00 |
| 84-7* | 5156290210 | CAMSHAFT SHIM | A/R | T=0.30 |
| 84-8* | 5156190390 | CAMSHAFT SHIM | A/R | T=0.70 |
| 84-9* | 1156190900 | CAMSHAFT SHIM | A/R | T=1.40 |
| 85* | 5156290150 | CAMSHAFT SHIM | A/R | T=0.10 |
| 85-1* | 5156290160 | CAMSHAFT SHIM | A/R | T=0.30 |
| 85-2* | 5156290170 | CAMSHAFT SHIM | A/R | T=0.14 |
| 85-3* | 5156290180 | CAMSHAFT SHIM | A/R | T=0.16 |
| 85-4* | 5156290190 | CAMSHAFT SHIM | A/R | T=0.18 |
| 85-5* | 5156290200 | CAMSHAFT SHIM | A/R | T=0.50 |
| 85-6* | 5156190380 | CAMSHAFT SHIM | A/R | T=1.00 |
| 85-7* | 5156290210 | CAMSHAFT SHIM | A/R | T=0.30 |
| 85-8* | 5156190390 | CAMSHAFT SHIM | A/R | T=0.70 |
| 85-9* | 1156190900 | CAMSHAFT SHIM | A/R | T=1.40 |
| 93* | 5156290050 | HOUSING COVER | 1 | |
| 95* | 9019006140 | BOLT | 4 | |

ISUZU C240 --- INJECTION PUMP COMP. ASSY.

INJECTION PUMP COMP. ASSY.

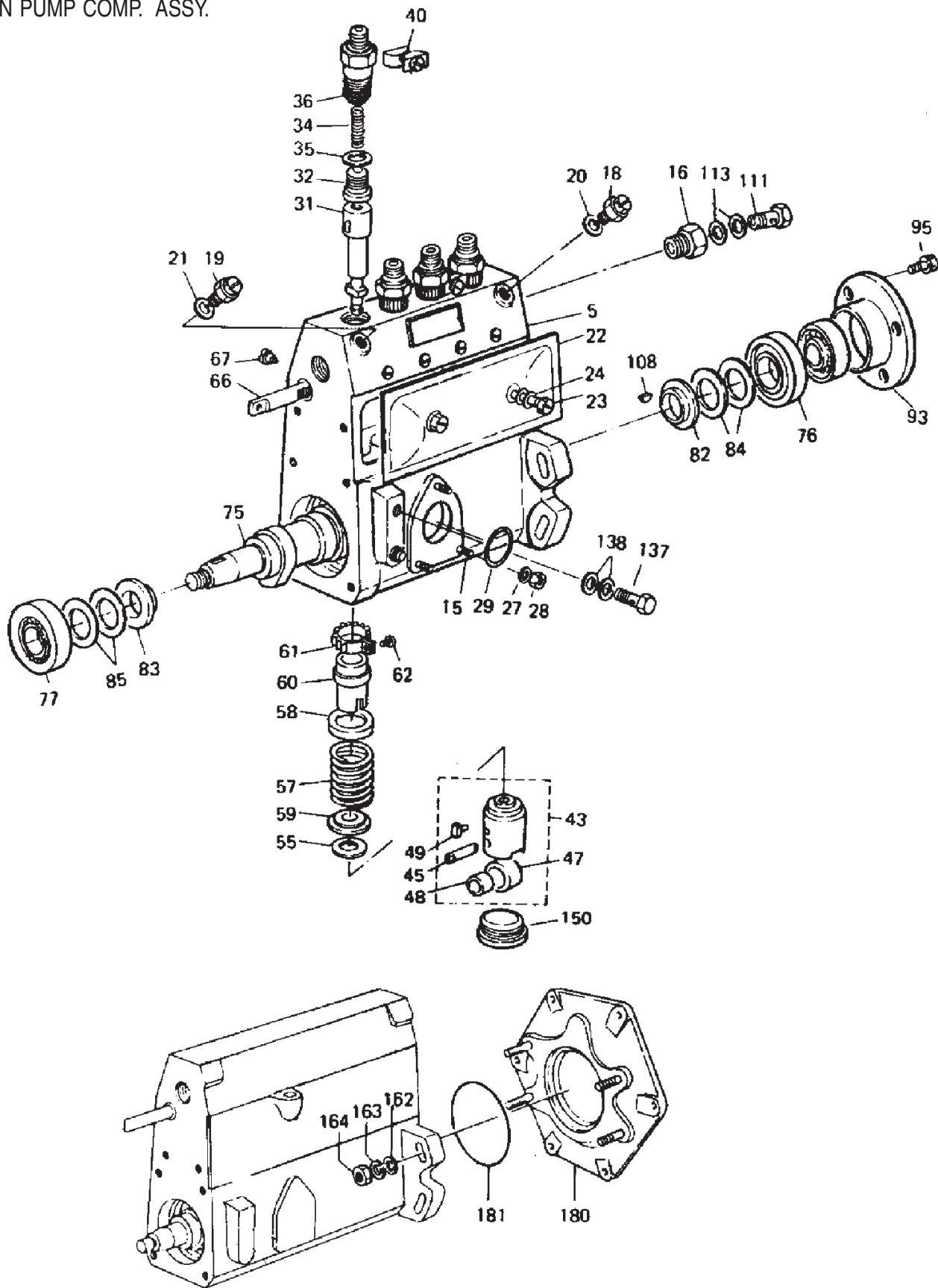

ISUZU C240 --- INJECTION PUMP COMP. ASSY.

INJECTION PUMP COMP. ASSY.

| <u>NO.</u> | <u>PART NO.</u> | <u>ITEM</u> | <u>QTY.</u> | <u>REMARKS</u> |
|------------|-----------------|----------------|-------------|----------------|
| 108* | 9812214110 | KEY | 1 | |
| 111* | 1156190820 | BOLT | 1 | |
| 113* | 1157590010 | PACKING | 2 | |
| 137* | 9097060370 | BOLT | 1 | |
| 138* | 1096350070 | PACKING | 2 | |
| 150* | 9812150780 | TAPPET PLUG | 4 | |
| 162* | 9091606100 | PLAIN WASHER | 4 | |
| 163* | 9091505100 | LOCK WASHER | 4 | |
| 164* | 5156390020 | NUT | 4 | |
| 180* | 9197510790 | BRACKET | 1 | |
| 181* | 9099205760 | O RING PACKING | 1 | |

ISUZU C240 ---GOVERNOR COMP. ASSY.

GOVERNOR COMP. ASSY.

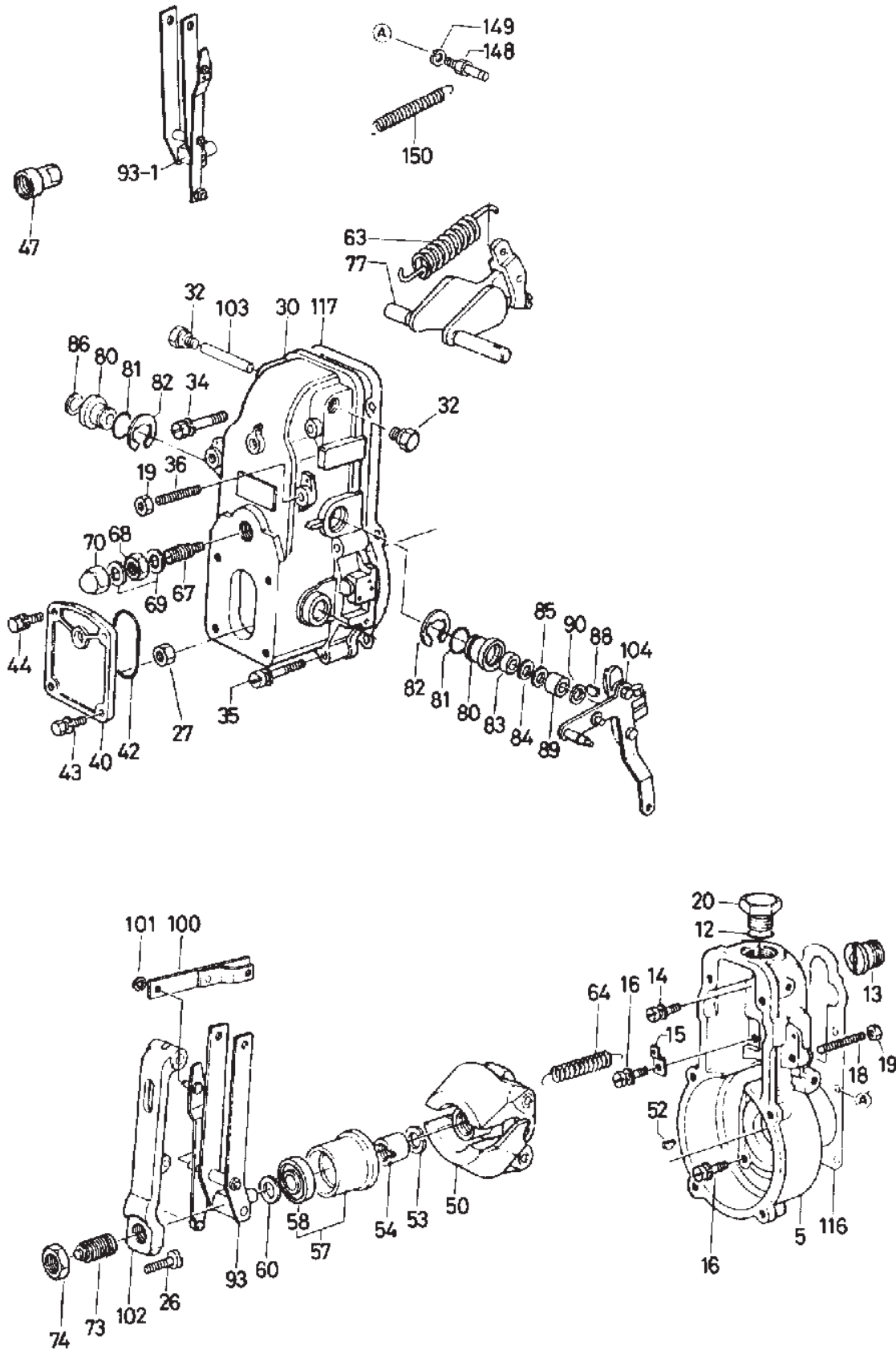

ISUZU C240 --- GOVERNOR COMP. ASSY.

GOVERNOR COMP. ASSY.

| <u>NO.</u> | <u>PART NO.</u> | <u>ITEM</u> | <u>QTY.</u> | <u>REMARKS</u> |
|------------|-----------------|-----------------|-------------|-----------------|
| 5 | 1157210040 | HOUSING | 1 | INCL. ITEMS W/* |
| 12* | 1157290150 | O RING PACKING | 1 | |
| 13* | 9813150650 | ADAPTER | 1 | |
| 14* | 9019008180 | BOLT | 1 | |
| 15* | 9813253970 | HOUSING PLATE | 1 | |
| 16* | 901906140 | BOLT | 6 | |
| 18* | 5157291230 | SCREW | 1 | |
| 19* | 9813252370 | NUT | 2 | |
| 20* | 1157290380 | HOUSING PLUG | 1 | |
| 26* | 9813251820 | SCREW | 1 | |
| 27* | 9813261120 | NUT | 1 | |
| 30* | 5157210080 | COVER | 1 | |
| 32* | 5157290530 | PLUG | 2 | |
| 34* | 5157290540 | BOLT | 2 | |
| 35* | 5157290330 | BOLT | 2 | |
| 36* | 5157291230 | SCREW | 1 | |
| 40* | 9813211860 | COVER | 1 | |
| 42* | 9813919070 | O RING PACKING | 1 | |
| 43* | 5157290630 | BOLT | 2 | |
| 44* | 9019006160 | BOLT | 2 | |
| 47* | 9812350340 | CAP | 1 | |
| 50* | 9813213230 | FLYWEIGHT ASSY. | 1 | |
| 52* | 5156190490 | KEY | 1 | |
| 53* | 5157290340 | LOCK WASHER | 1 | |
| 54* | 9813250860 | NUT | 1 | |
| 57* | 5157190080 | SLEEVE | 1 | INCL. ITEM W/# |
| 58*# | 9000902290 | BEARING | 1 | |
| 60* | 9813250880 | SHIM | A/R | T=0.20 |
| 60-1* | 9813255510 | SHIM | A/R | T=0.30 |
| 60-2* | 9813255520 | SHIM | A/R | T=0.40 |
| 60-3* | 9813255530 | SHIM | A/R | T=1.00 |
| 63* | 9813222100 | GOVERNOR SPRING | 1 | |
| 64* | 5157230820 | LINK SPRING | 1 | |
| 67* | 1157230200 | CAPSULE SPRING | 1 | |
| 68* | 9813932040 | NUT | 1 | |
| 69* | 1156390080 | GASKET | 2 | |
| 73* | 9813216360 | CAPSULE SPRING | 1 | |
| 74* | 9008130230 | NUT | 1 | |
| 77* | 9813217210 | LEVER | 1 | |
| 80* | 9813250990 | BUSHING | 2 | |
| 81* | 9813212050 | O RING PACKING | 2 | |
| 82* | 9091854150 | SNAP RING | 2 | |

ISUZU C240 --- GOVERNOR COMP. ASSY.

GOVERNOR COMP. ASSY.

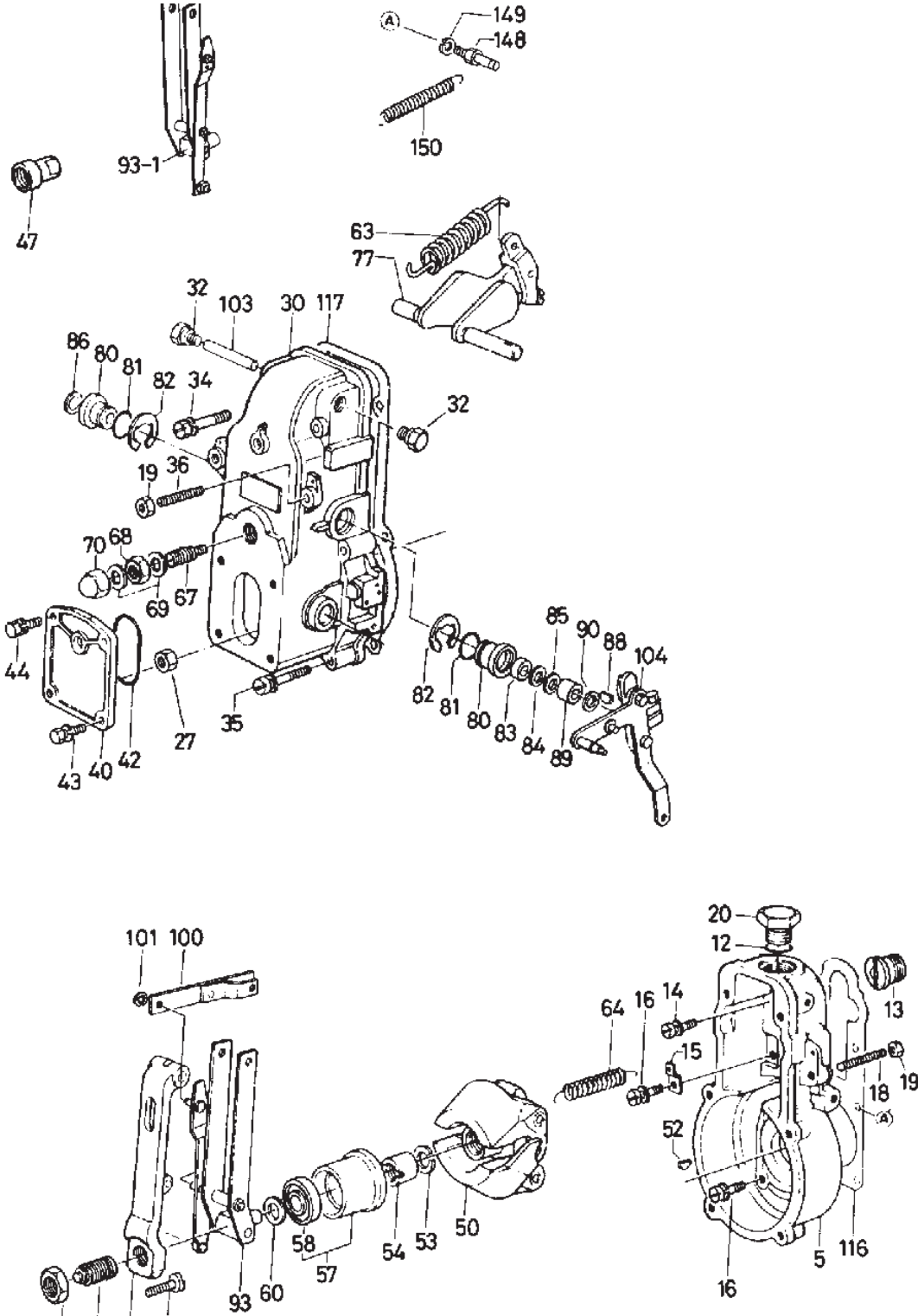

ISUZU C240 --- GOVERNOR COMP. ASSY.

GOVERNOR COMP. ASSY.

| <u>NO.</u> | <u>PART NO.</u> | <u>ITEM</u> | <u>QTY.</u> | <u>REMARKS</u> |
|------------|-----------------|-------------------|-------------|----------------|
| 83* | 9813212200 | OIL SEAL | 1 | |
| 84* | 9813251730 | SHIM | 1 | T=0.50 |
| 85* | 9813250970 | SHIM | A/R | T=0.30 |
| 86* | 9813253180 | PLUG | 1 | |
| 88* | 9813250300 | KEY | 1 | |
| 89* | 9813913070 | COLLAR | 1 | |
| 90* | 9813254880 | WASHER | A/R | |
| 93* | 5157250160 | GUIDE LEVER ASSY. | 1 | |
| 100* | 9813217130 | LINK | 1 | |
| 101* | 1157290230 | SNAP RING | 1 | |
| 102* | 5157250170 | TENSION LEVER | 1 | |
| 103* | 9813250620 | PIN | 1 | |
| 104* | 5157250490 | LEVER | 1 | |
| 116* | 1157290010 | GASKET | 1 | |
| 117* | 1157290020 | GASKET | 1 | |
| 148* | 5157291120 | BOLT | 1 | |
| 150* | 5157230880 | SPRING | 1 | |

ISUZU C240 --- FEED PUMP COMP. ASSY.

FEED PUMP COMP. ASSY.

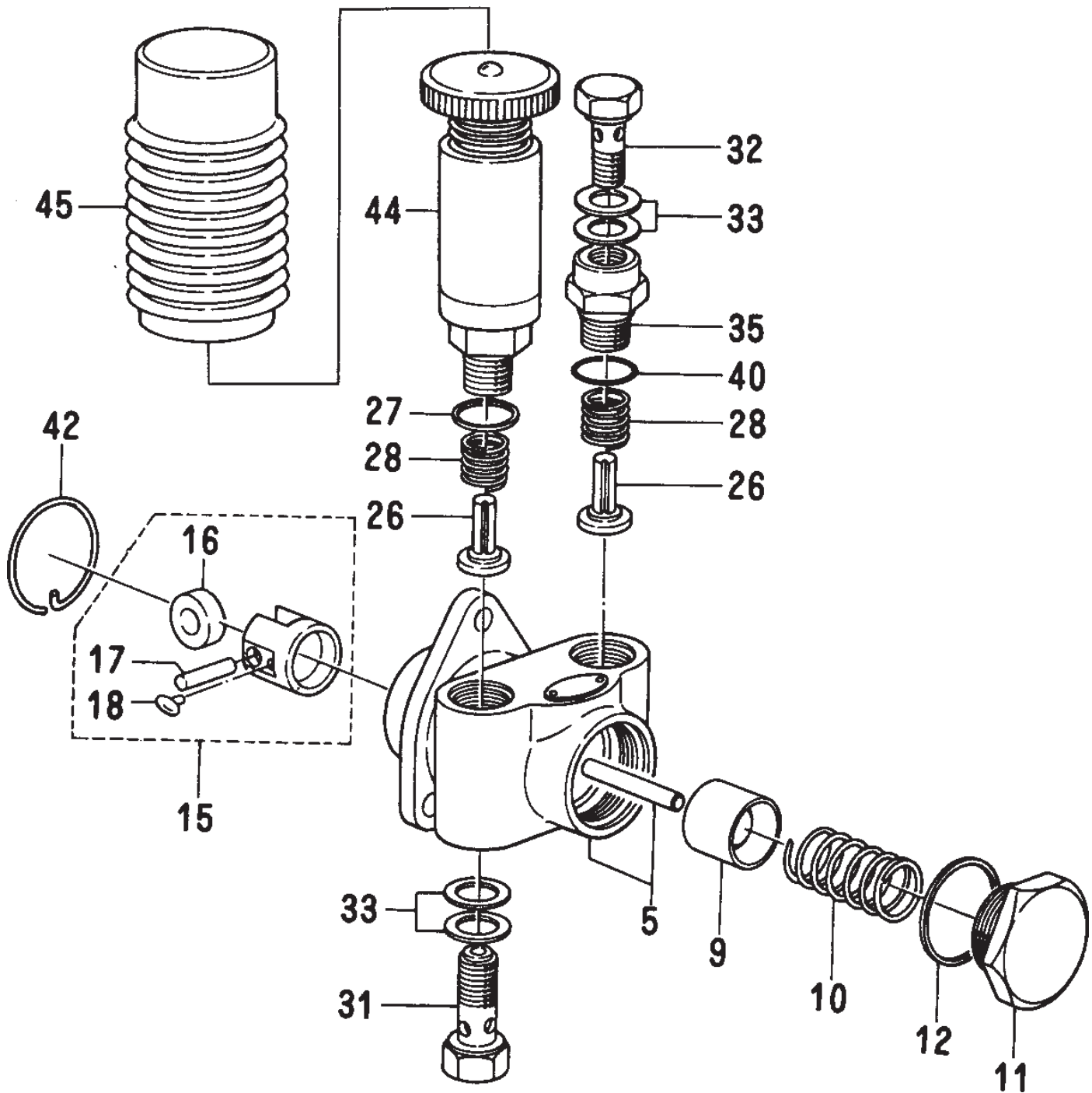

ISUZU C240 --- FEED PUMP COMP. ASSY.

FEED PUMP COMP. ASSY.

| <u>NO.</u> | <u>PART NO.</u> | <u>ITEM</u> | <u>QTY.</u> | <u>REMARKS</u> |
|------------|-----------------|------------------|-------------|---------------------|
| 5 | 5157510120 | HOUSING | 1 | INCL. ITEMS W/* |
| 9* | 9813512050 | PISTON | 1 | |
| 10* | 9813513030 | SPRING | 1 | |
| 11* | 9813550230 | PLUG | 1 | |
| 12* | 9813550350 | GASKET | 1 | |
| 15* | 5157540010 | TAPPET ASSY..... | 1 | INCL. ITEMS W/* |
| 16*# | 9813514030 | ROLLER | 1 | |
| 17*# | 9813514100 | PIN | 1 | |
| 18*# | 1157590020 | GUIDE | 2 | |
| 26* | 9813516020 | CHECK VALVE | 2 | |
| 27* | 1096230160 | GASKET | 1 | |
| 28* | 9813517020 | SPRING | 2 | |
| 31* | 9099063260 | BOLT | 1 | |
| 32* | 1156190820 | BOLT | 1 | |
| 33* | 1157590010 | PACKING | 4 | |
| 35* | 1157590030 | ADAPTER | 1 | |
| 40* | 1096230160 | PACKING | 1 | |
| 42* | 9813550250 | RING | 1 | |
| 44* | 9813521040 | PUMP | 1 | REPLACES 5157610050 |
| 45* | 9813550330 | COVER | 1 | |

ISUZU C240 --- AUTO TIMER COMP. ASSY.

AUTO TIMER COMP. ASSY.

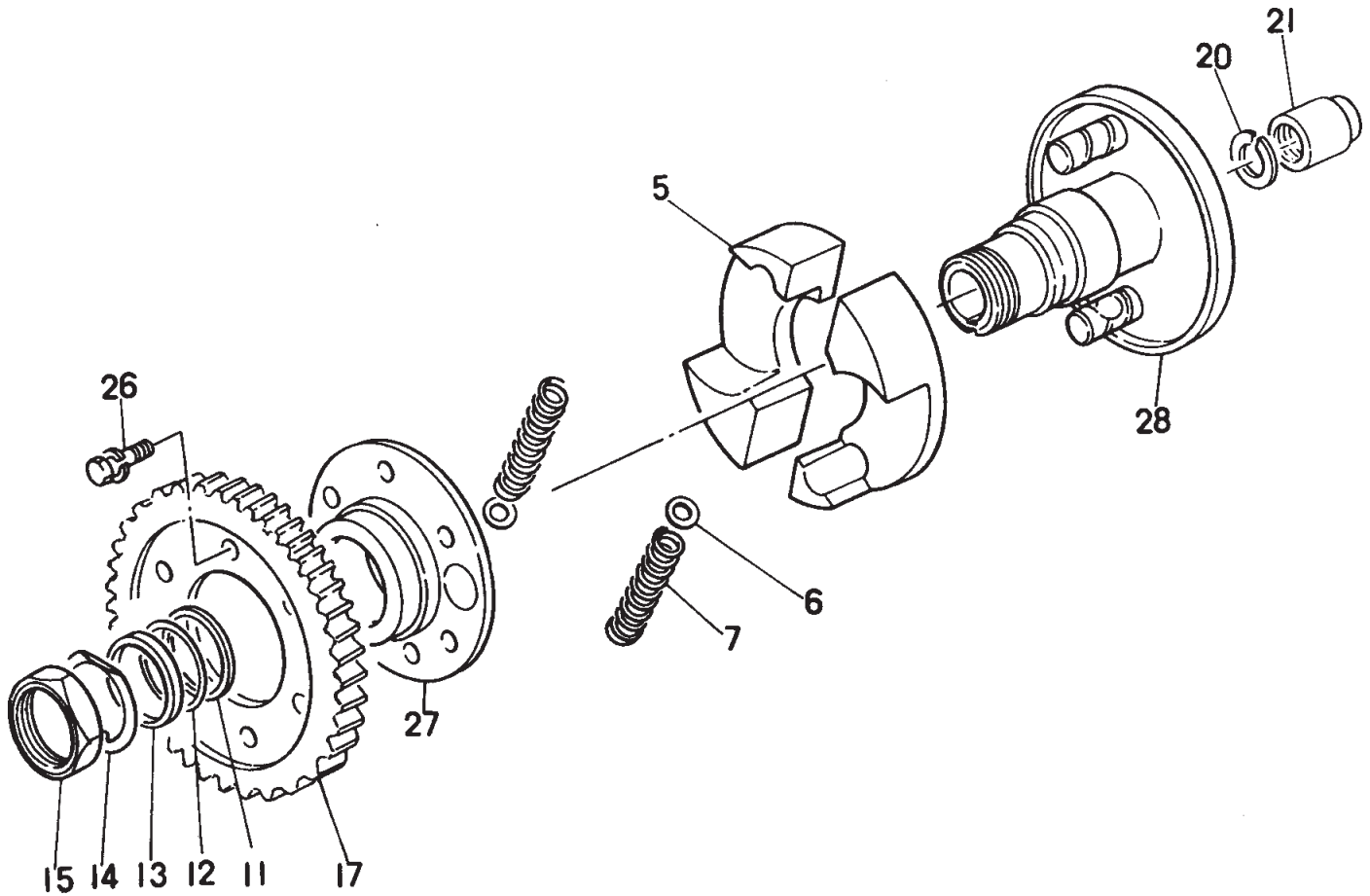

ISUZU C240 --- AUTO TIMER COMP. ASSY.

AUTO TIMER COMP. ASSY.

| <u>NO.</u> | <u>PART NO.</u> | <u>ITEM</u> | <u>QTY.</u> | <u>REMARKS</u> |
|------------|-----------------|-----------------|-------------|-----------------|
| 5 | 9813435050 | FLYWEIGHT | 2 | INCL. ITEMS W/* |
| 6* | 9813450430 | SHIM | A/R | |
| 6-1* | 9813450440 | SHIM | A/R | |
| 6-2* | 9813450450 | SHIM | A/R | |
| 6-3* | 5157490090 | SHIM | A/R | |
| 6-4* | 5157490100 | SHIM | A/R | |
| 6-5* | 5157490110 | SHIM | A/R | |
| 6-6* | 5157490680 | SHIM | A/R | |
| 6-7* | 5157490690 | SHIM | A/R | |
| 6-8* | 5157490700 | SHIM | A/R | |
| 6-9* | 5157490710 | SHIM | A/R | |
| 7* | 9813450720 | TIMER SPRING | 2 | |
| 11* | 9813453380 | WASHER | 1 | |
| 12* | 9813453250 | SHIM | A/R | |
| 12-1* | 9813453260 | SHIM | A/R | |
| 12-2* | 9813453400 | SHIM | A/R | |
| 12-3* | 9813453270 | SHIM | A/R | |
| 12-4* | 9813453280 | SHIM | A/R | |
| 12-5* | 9813453290 | SHIM | A/R | |
| 12-6* | 9813453300 | SHIM | A/R | |
| 12-7* | 9813453310 | SHIM | A/R | |
| 12-8* | 9813453320 | SHIM | A/R | |
| 13* | 5157490070 | WASHER | 1 | |
| 14* | 9813450520 | PLATE | 1 | |
| 15* | 9813453060 | NUT | 1 | |
| 17* | 5125240660 | GEAR | 1 | |
| 20-1* | 5156190480 | LOCK WASHER | 1 | |
| 21* | 1156190010 | NUT | 1 | |
| 26* | 5157490080 | BOLT | 6 | |
| 27* | 9813433050 | FLANGE | 1 | |
| 28* | 5157490280 | HOLDER | 1 | |

ISUZU C240 --- NOZZLE HOLDER COMP. ASSY.

NOZZLE HOLDER COMP. ASSY.

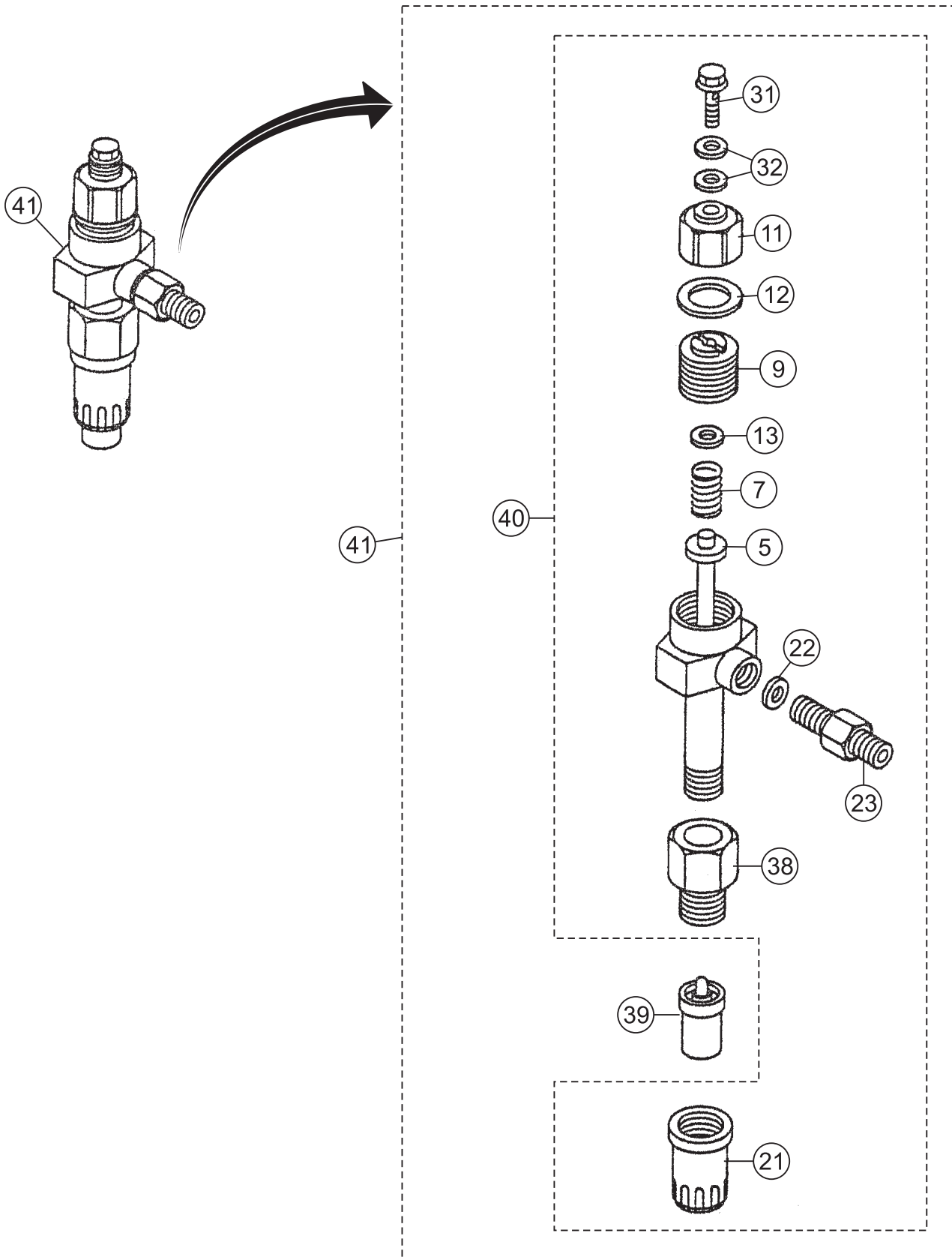

ISUZU C240 --- NOZZLE HOLDER COMP. ASSY.

NOZZLE HOLDER COMP. ASSY.

| <u>NO.</u> | <u>PART NO.</u> | <u>ITEM</u> | <u>QTY.</u> | <u>REMARKS</u> |
|------------|-----------------|------------------------------|-------------|--------------------|
| 5%# | 5153410020 | PUSH ROD | 4 | |
| 7%# | 5153430020 | SPRING | 4 | |
| 9%# | 9153396010 | SCREW | 4 | |
| 11%# | 5153340030 | NUT | 4 | |
| 12%# | 9153390560 | GASKET | 4 | |
| 13%# | 9153390570 | WASHER | 4 | |
| 21%# | 9153326030 | NUT | 4 | |
| 22%# | 9153520050 | GASKET | 4 | |
| 23%# | 9153510070 | CONNECTOR | 4 | |
| 31%# | 5153490010 | BOLT | 4 | |
| 32%# | 9095714080 | GASKET | 8 | |
| 38%# | 9153596010 | SCREW | 4 | |
| 39% | 5153110060 | NOZZLE INJECTOR | 4 | |
| 40% | 8941145150 | HOLDER ASSY W/O NOZZLE | 4 | INCLUDES ITEMS W/# |
| 41 | 5153000391 | NOZZLE AND HOLDER ASSY | 4 | INCLUDES ITEMS W/% |

ISUZU C240 ---STARTER COMP. ASSY.

STARTER COMP. ASSY.

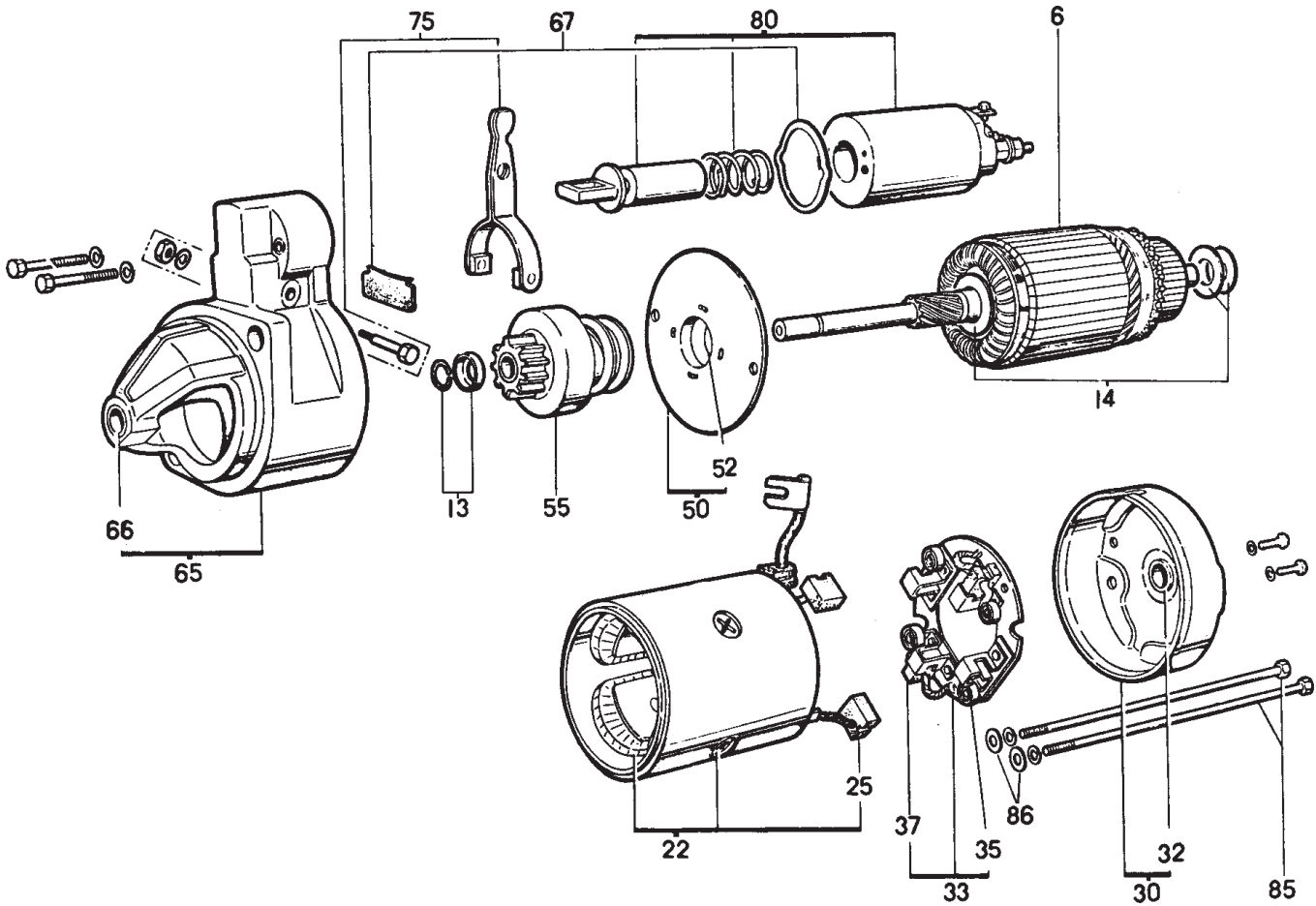

ISUZU C240 --- STARTER COMP. ASSY.

STARTER COMP. ASSY.

| <u>NO.</u> | <u>PART NO.</u> | <u>ITEM</u> | <u>QTY.</u> | <u>REMARKS</u> |
|------------|-----------------|-----------------------|-------------|-----------------|
| 6 | 5811210160 | ARMATURE ASSY. | 1 | INCL. ITEMS W/* |
| 13* | 5811291050 | PINION STOPPER | 1 | |
| 14* | 5811290030 | WASHER SET | 1 | |
| 22* | 5811120100 | FIELD COIL ASSY. | 1 | INCL. ITEM W/> |
| 25*> | 5811160480 | BRUSH, + | 1 | |
| 30* | 5811150130 | REAR COVER ASSY. | 1 | INCL. ITEM W/% |
| 32*% | 5811190120 | REAR METAL | 1 | |
| 33* | 5811160180 | BRUSH HOLDER | 1 | INCL. ITEMS W/@ |
| 35*@ | 5811170060 | BRUSH SPRING | 4 | |
| 37*@ | 5811160490 | BRUSH, - | 2 | |
| 50* | 5811190130 | BRACKET ASSY. | 1 | INCL. ITEM W/& |
| 52*& | 9821121340 | CENTER METAL | 1 | |
| 55* | 5811230070 | CLUTCH ASSY. | 1 | |
| 65* | 5811130170 | GEAR CASE ASSY. | 1 | INCL. ITEM W/# |
| 66*# | 5811190260 | FRONT METAL | 1 | |
| 67* | 5811290680 | DUST COVER | 1 | |
| 75* | 5811270130 | SHIFT LEVER ASSY. | 1 | |
| 80* | 5811510290 | MAGNETIC SWITCH ASSY. | 1 | |
| 85* | 5811290710 | BOLT | 2 | |
| 86* | 5811290730 | WASHER | 2 | |

ISUZU C240 --- ALTERNATOR COMP. ASSY.

ALTERNATOR COMP. ASSY. (OCT. 1992~)

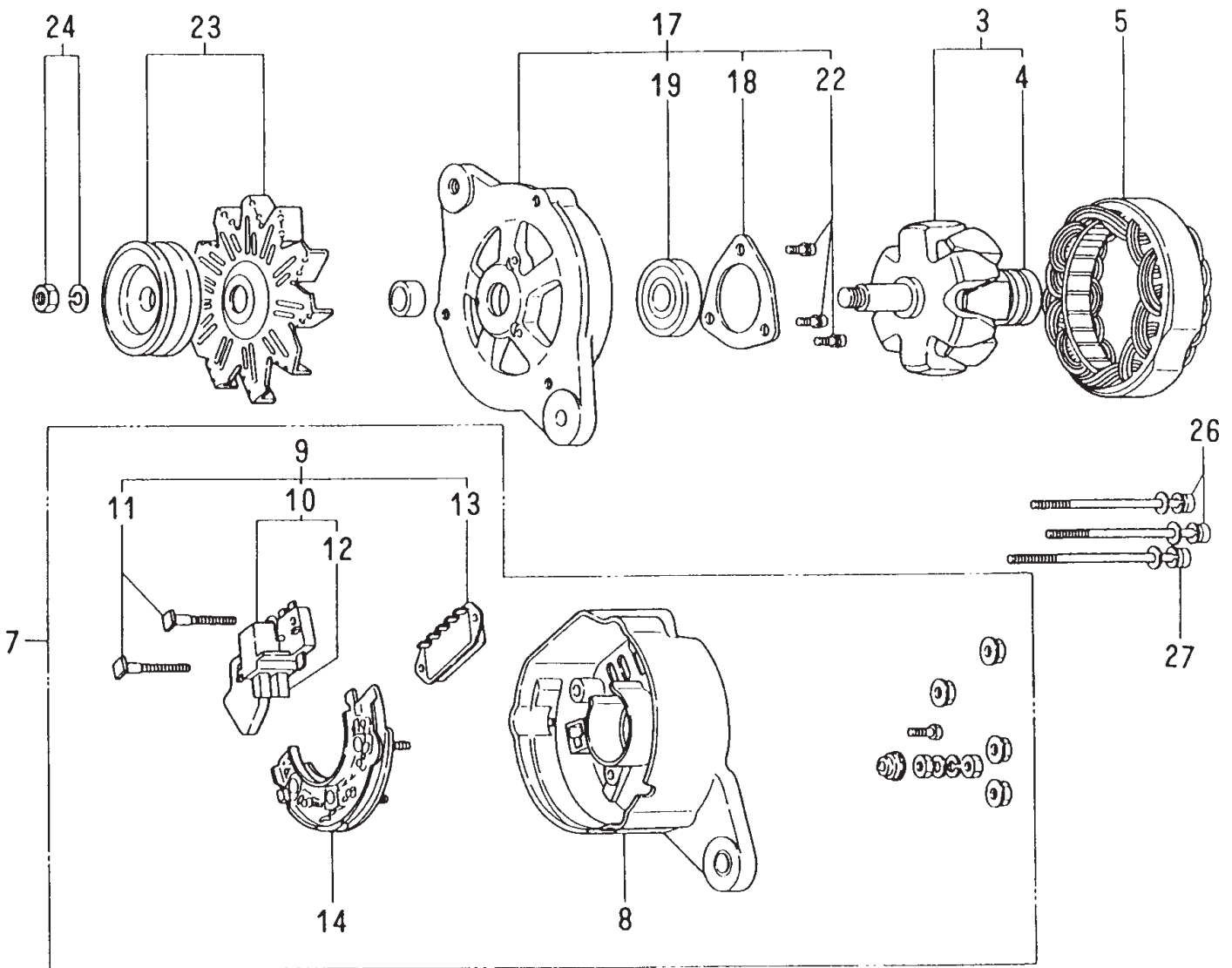

ISUZU C240 --- ALTERNATOR COMP. ASSY.

ALTERNATOR COMP. ASSY. (OCT. 1992~)

| <u>NO.</u> | <u>PART NO.</u> | <u>ITEM</u> | <u>QTY.</u> | <u>REMARKS</u> |
|------------|-----------------|------------------------|-------------|-------------------------------|
| 3 | 5812210630 | ROTOR ASSY. | 1 | INCL. ITEMS W/* AND W/> |
| 4*> | 9000901810 | BALL BEARING | 1 | |
| 5* | 5812110580 | STRATOR ASSY. | 1 | |
| 7* | 5812141310 | REAR COVER ASSY. | 1 | INCL. ITEMS W/# |
| 8*# | 5812141320 | REAR COVER | 1 | |
| 9*# | 5812190360 | BRUSH REGULATOR | 1 | INCL. ITEMS W/% |
| 10*#% | 5812150460 | BRUSH ASSY. | 1 | |
| 11*#% | 5812291660 | BOLT | 2 | |
| 12*#% | 5812150400 | BRUSH | 2 | |
| 13*#% | 5812700040 | REGULATOR ASSY. | 1 | |
| 14*# | 5812620050 | RECTIFIER | 1 | |
| 17* | 5812130430 | FRONT COVER ASSY. | 1 | INCL. ITEMS W/& |
| 18*& | 5812290290 | RETAINER | 1 | |
| 19*& | 5098000870 | BALL BEARING | 1 | |
| 22*& | 5812291650 | SCREW KIT | 1 | |
| 23* | 5812220760 | PULLEY ASSY. | 1 | |
| 24* | 9822350150 | NUT | 1 | |
| 26* | 5812291820 | BOLT | 2 | |
| 27* | 5812291830 | BOLT | 1 | |

ISUZU C240 ---ALTERNATOR COMP. ASSY.

ALTERNATOR COMP. ASSY. (BEFORE OCT. 1992)

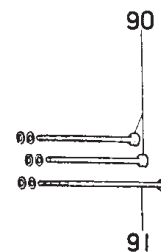
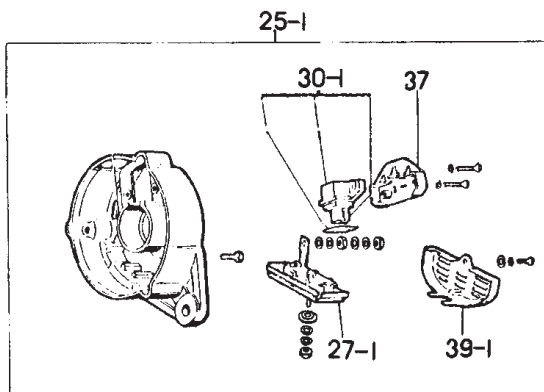
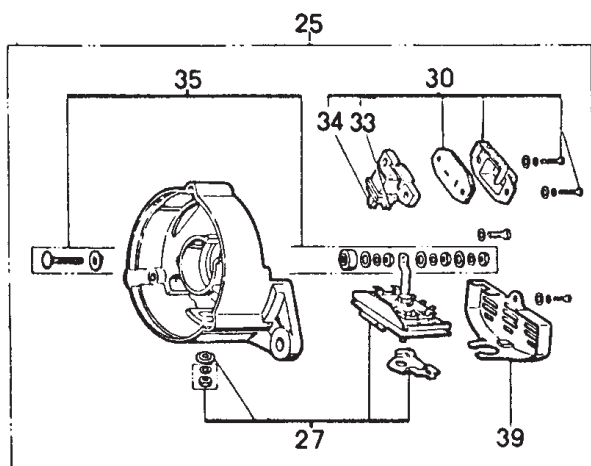
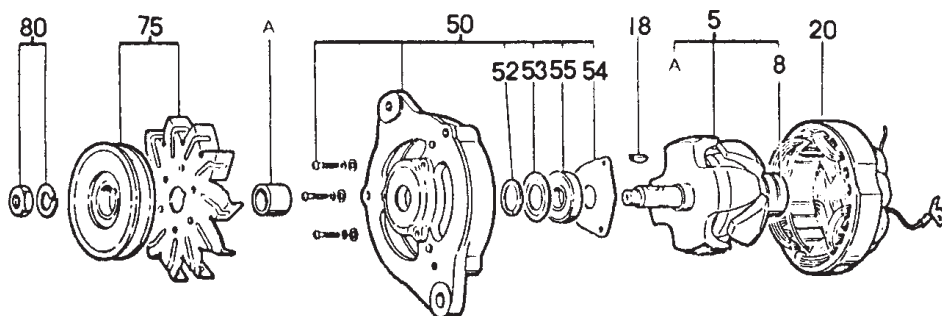

ISUZU C240 --- ALTERNATOR COMP. ASSY.

ALTERNATOR COMP. ASSY. (BEFORE OCT. 1992)

| <u>NO.</u> | <u>PART NO.</u> | <u>ITEM</u> | <u>QTY.</u> | <u>REMARKS</u> |
|------------|-----------------|------------------------|-------------|-----------------------|
| 5 | 5812210100 | ROTOR ASSY. | 1 | INCL. ITEMS W/* |
| 8* | 9000901810 | BALL BEARING | 1 | |
| 18* | 9822250270 | KEY | 1 | |
| 20* | 5812110090 | STRATOR ASSY. | 1 | |
| 25* | 5812140010 | COVER ASSY. | 1 | INCL. ITEMS W/# |
| 27*# | 9822316190 | RECTIFIER ASSY. | 1 | |
| 30*# | 5812150010 | HOLDER ASSY. | 1 | |
| 33*# | 9822316170 | BRUSH | 1 | |
| 34*# | 9822316180 | BRUSH | 1 | |
| 35*# | 9822350700 | BOLT ASSY. | 1 | |
| 39*# | 9822319040 | RECTIFIER COVER | 1 | |
| 50* | 9822313080 | FRONT COVER ASSY. | 1 | INCL. ITEMS W/& |
| 52*& | 9822158230 | PACKING | 1 | |
| 53*& | 9822158240 | RETAINER | 1 | |
| 54*& | 9822159170 | RETAINER BRIDGE | 1 | |
| 55*& | 9000901820 | FRONT BALL BEARING | 1 | |
| 75* | 5812220140 | PULLEY ASSY. | 1 | |
| 80* | 9822350740 | NUT | 1 | |
| 90* | 9822350720 | BOLT | 2 | L=85 |
| 91* | 9822350730 | BOLT | 2 | L=95 |

TERMS AND CONDITIONS OF SALE — PARTS

PAYMENT TERMS

Terms of payment for parts are net 30 days.

FREIGHT POLICY

All parts orders will be shipped collect or prepaid with the charges added to the invoice. All shipments are F.O.B. point of origin. Multiquip's responsibility ceases when a signed manifest has been obtained from the carrier, and any claim for shortage or damage must be settled between the consignee and the carrier.

MINIMUM ORDER

The minimum charge for orders from Multiquip is \$15.00 net. Customers will be asked for instructions regarding handling of orders not meeting this requirement.

RETURNED GOODS POLICY

Return shipments will be accepted and credit will be allowed, subject to the following provisions:

1. A Returned Material Authorization must be approved by Multiquip prior to shipment.
2. To obtain a Return Material Authorization, a list must be provided to Multiquip Parts Sales that defines item numbers, quantities, and descriptions of the items to be returned.
 - a. The parts numbers and descriptions must match the current parts price list.
 - b. The list must be typed or computer generated.
 - c. The list must state the reason(s) for the return.
 - d. The list must reference the sales order(s) or invoice(s) under which the items were originally purchased.
 - e. The list must include the name and phone number of the person requesting the RMA.
3. A copy of the Return Material Authorization must accompany the return shipment.
4. Freight is at the sender's expense. All parts must be returned freight prepaid to Multiquip's designated receiving point.

5. Parts must be in new and resalable condition, in the original Multiquip package (if any), and with Multiquip part numbers clearly marked.
6. The following items are not returnable:
 - a. Obsolete parts. (If an item is in the price book and shows as being replaced by another item, it is obsolete.)
 - b. Any parts with a limited shelf life (such as gaskets, seals, "O" rings, and other rubber parts) that were purchased more than six months prior to the return date.
 - c. Any line item with an extended dealer net price of less than \$5.00.
 - d. Special order items.
 - e. Electrical components.
 - f. Paint, chemicals, and lubricants.
 - g. Decals and paper products.
 - h. Items purchased in kits.
7. The sender will be notified of any material received that is not acceptable.
8. Such material will be held for five working days from notification, pending instructions. If a reply is not received within five days, the material will be returned to the sender at his expense.
9. Credit on returned parts will be issued at dealer net price at time of the original purchase, less a 15% restocking charge.
10. In cases where an item is accepted, for which the original purchase document can not be determined, the price will be based on the list price that was effective twelve months prior to the RMA date.
11. Credit issued will be applied to future purchases only.

PRICING AND REBATES

Prices are subject to change without prior notice. Price changes are effective on a specific date and all orders received on or after that date will be billed at the revised price. Rebates for price declines and added charges for price increases will not be made for stock on hand at the time of any price change.

Multiquip reserves the right to quote and sell direct to Government agencies, and to Original Equipment Manufacturer accounts who use our products as integral parts of their own products.

SPECIAL EXPEDITING SERVICE

A \$35.00 surcharge will be added to the invoice for special handling including bus shipments, insured parcel post or in cases where Multiquip must personally deliver the parts to the carrier.

LIMITATIONS OF SELLER'S LIABILITY

Multiquip shall not be liable hereunder for damages in excess of the purchase price of the item with respect to which damages are claimed, and in no event shall Multiquip be liable for loss of profit or good will or for any other special, consequential or incidental damages.

LIMITATION OF WARRANTIES

No warranties, express or implied, are made in connection with the sale of parts or trade accessories nor as to any engine not manufactured by Multiquip. Such warranties made in connection with the sale of new, complete units are made exclusively by a statement of warranty packaged with such units, and Multiquip neither assumes nor authorizes any person to assume for it any other obligation or liability whatever in connection with the sale of its products. Apart from such written statement of warranty, there are no warranties, express, implied or statutory, which extend beyond the description of the products on the face hereof.

Effective: February 22, 2006

OPERATION AND PARTS MANUAL

HERE'S HOW TO GET HELP

PLEASE HAVE THE MODEL AND SERIAL
NUMBER ON-HAND WHEN CALLING

MULTIQUIP CORPORATE OFFICE

18910 Wilmington Ave Tel. (800) 421-1244
Carson, CA 90746 Fax (800) 537- 3927
Contact: mq@multiquip.com
Web: www.multiquip.com

MQ Power

1800 Water Ridge Rd. Tel. (800) 883-2551
Suite 500/600 Fax (972) 315-1847
Lewisville, TX 75057
Contact: mqpower@multiquip.com
Web: www.mqpower.com

MQ Parts Department

800-427-1244 Fax: 800-672-7877
310-537-3700 Fax: 310-637-3284

Service/Tech Support/Warranty

800-835-2551 Fax: 310-638-8046

© COPYRIGHT 2010, MULTIQUIP INC.

MQ Power and the MQ Power logo are registered trademarks of Multiquip Inc. and may not be used, reproduced, or altered without written permission. All other trademarks are the property of their respective owners and used with permission.

This manual MUST accompany the equipment at all times. This manual is considered a permanent part of the equipment and should remain with the unit if resold.

The information and specifications included in this publication were in effect at the time of approval for printing. Illustrations, descriptions, references and technical data contained in this manual are for guidance only and may not be considered as binding. Multiquip Inc. reserves the right to discontinue or change specifications, design or the information published in this publication at any time without notice and without incurring any obligations.

Further, MQ Power disclaims any warranties or guaranties, expressed or implied, with regards to the information contained in this manual.

Your Local Dealer is:

Manufactured for
Multiquip Inc.
by
DENYO CO., LTD, JAPAN

