

Mix-N-Go Concrete Mixers

Welcome to the future of portable concrete mixers.



Model MC-3SEA

Model MC-3PEA

The Mix-N-Go Concrete Mixer combines a host of performance-enhancing features with ease of transportation to, from and around the job site. It can mix up to three cubic feet of material, making the Mix-N-Go the tool of choice for homeowners and small contractors.

With a stronger frame and sturdy steel or polyethylene drum, the Mix-N-Go is ideal for small footings and bases, binding block and concrete patching. It is available with a gasoline engine or electric motor for operator convenience and for increased versatility. It can also be used as a wheelbarrow to transport concrete, debris and other material around the job site.

When the job is complete, the compact Mix-N-Go fits neatly into the trunk of a car.

- New replaceable blades bolted to the drum.
- Choice of steel or polyethylene drums.
- Engine options — Gasoline or ¾ HP, 115 single-phase UL- and CSA-approved electric motor.*
- Job site convenience — can use standard household power.
- Mixer stand allows drum to rotate 360 degrees.
- New on/off switch protection — water-resistant and dust proof.
- Pneumatic tires.

Construction Starts Here

www.multiquip.com

Mix-N-Go Concrete Mixers – Specifications

Model	Drum Construction	Max. Mixing Capacity*	Engine**	Height in. (mm)	Width in. (mm)	Length in. (mm)	Stand Weight lb. (kg)	Dry Weight lb. (kg)
MC3SEA	Steel	3.0 cu. ft.	¾ HP, 115V, 1ø Electric Motor	34 (863.6)	23⅝ (584.2)	48½ (1219.2)	35 (15.9)	138 (62.6)
MC3PEA	Polyethylene	3.0 cu. ft.	¾ HP, 115V, 1ø Electric Motor	34 (863.6)	23⅝ (584.2)	48½ (1219.2)	35 (15.9)	138 (62.6)
MC3SBA	Steel	3.0 cu. ft.	Briggs & Stratton 148cc	34 (863.6)	23⅝ (584.2)	48½ (1219.2)	35 (15.9)	132 (59.9)
MC3PBA	Polyethylene	3.0 cu. ft.	Briggs & Stratton 148cc	34 (863.6)	23⅝ (584.2)	48½ (1219.2)	35 (15.9)	132 (59.9)

© COPYRIGHT 2009, MULTQUIP INC.



Bolt-in replaceable mixing blades
Stronger, thicker drum (available in steel or poly)

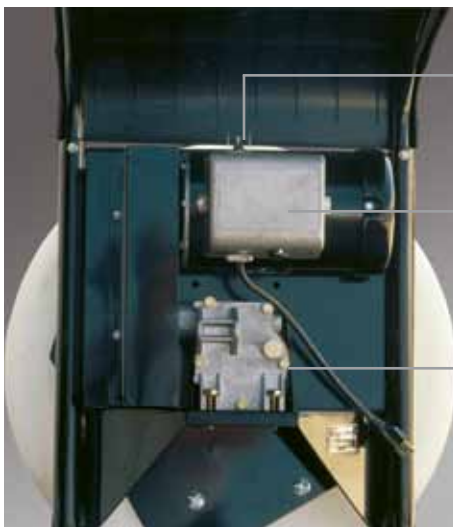

Water-resistant, dust-proof on/off switch
Strong ¾ HP brushless motor, UL and CSA approved
Improved gearbox; gears immersed in oil for long trouble-free life

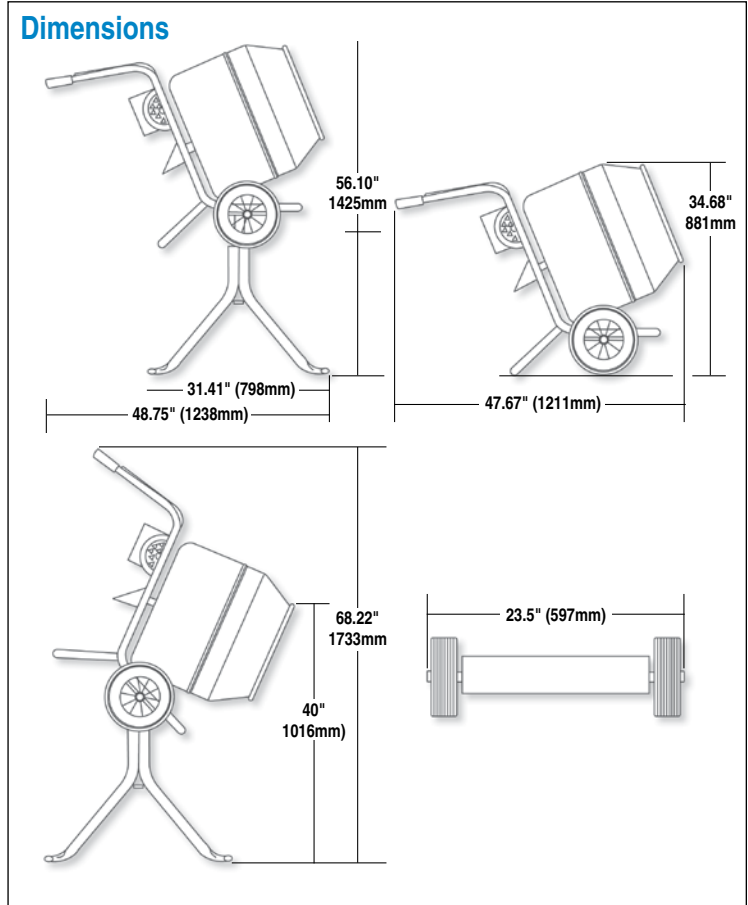

* Actual mix capacity may vary depending on aggregate size and mix design.

** Engine power ratings are calculated by the individual engine manufacturer and the rating method may vary among engine manufacturers. Multiquip Inc. and its subsidiary companies makes no claim, representation or warranty as to the power rating of the engine on this equipment and disclaims any responsibility or liability of any kind whatsoever with respect to the accuracy of the engine power rating. Users are advised to consult the engine manufacturer's owners manual and its website for specific information regarding the engine power rating.

All features and specifications are subject to change without notice.

Your Multiquip dealer is:



MULTIQUIP INC.
POST OFFICE BOX 6254
CARSON, CA 90749
310-537-3700 • 800-421-1244
FAX: 310-537-3927
E-MAIL: mq@multiquip.com
www.multiquip.com