

WALK-BEHIND TROWELS

**MQ WHITEMAN**

Pioneering concrete  
finishing since 1939.



**MQ Whiteman power trowels** have been at the center of the concrete finishing world since 1939. Our commitment to innovation and development enables us to offer the industry's premier line up of concrete finishing equipment.

**Top quality components.** Concrete contractors demand reliable equipment to get the job done right. The MQ Whiteman gearbox uses a heat-treated worm gear and composite bronze gear to ensure that your machine isn't sidelined during a critical job.

**Low cost of ownership.** Our spider assembly uses high-strength wear plates made of trowel steel to prevent wear on key components. Repairing your trowel shouldn't be costly so we make certain our replacement parts are priced right.

### Handle Features:

- Ergonomic design provides more comfort and helps eliminate operator fatigue
- Built in height adjustment and isolation mounts.



### QXH-Series QuickPitch™ handle

A patented spring-loaded design enables the operator to react rapidly to changing concrete conditions. Blade pitch is increased or decreased in 1/8" increments by moving the latching lever back and forth.



### SXH-Series Standard handle

A favorite of contractors who prefer to have infinite blade pitch control. The large knob makes it easy to increase or decrease blade pitch to the desired angle.

**The Industry's Best Gearboxes —**  
heavy-duty design for years of trouble-free service.



**Upper Wear-Plate**  
Manufactured of trowel steel to prevent bearing wear.

**Thrust Collar Assembly**  
Sealed Thrust Bearing for years of trouble-free service.



**Bronze Bushing**  
Eliminates wear on the thrust collar and spider, providing tighter running tolerance.



**Lower Wear-Plate**  
Prevents wear on thrust collar surface

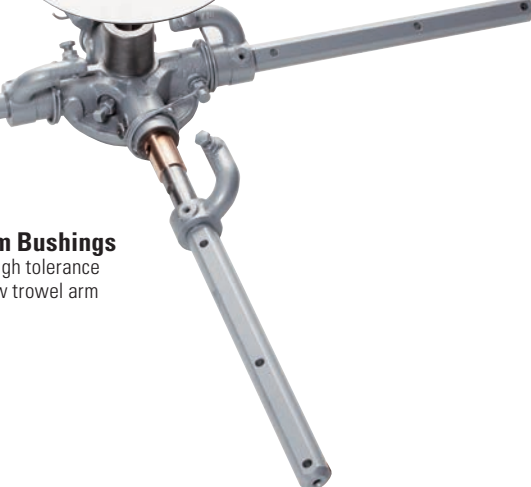

**Spider Trowel Arm Bushings**  
Replacement of these high tolerance bushings assure like new trowel arm alignment.

# MQ WHITEMAN

## B-SERIES — 46" DIAMETER

The MQ Whiteman walk-behind power trowel delivers high horsepower, excellent rotor speed and built in durability. It has been the favorite of concrete contractors for many generations.

- 1 Height adjustable handlebar includes vibration dampening for superior ergonomics
- 2 Choose an optional QuickPitch™ or standard knob-style pitch control
- 3 Lifting bail
- 4 Inertia shut off switch to ensure safety on the job
- 5 Heavy-duty centrifugal clutch protected by fully enclosed belt guard
- 6 Four blade spider assembly with original combination blades, stabilizer ring and balanced for smooth finishing
- 7 Access panel for easy service and blade replacement



### B46H90

Honda GX270  
Centrifugal Clutch  
60-130 RPM  
(shown with QXH QuickPitch™ handle)

### ALSO AVAILABLE

### B46B90

Briggs & Stratton 8.5kW engine  
60-130 RPM  
Centrifugal Clutch

### B46H11H

Honda GX340  
90-155 RPM  
Centrifugal Clutch  
Ideal for high speed burnishing

# MQ WHITEMAN

## J-SERIES — 36" DIAMETER

The **MQ Whiteman J-Series** incorporates amazing balance, durability, and your choice of a Standard or QuickPitch™ handle, providing contractors with the ideal machine for residential and general construction work.

### J36H55

Honda GX160; Centrifugal Clutch;  
60-115 RPM; (Shown w/ Optional  
SXH Standard handle)



### J36B65

Vanguard 6.5 HP; Centrifugal Clutch;  
60-115 RPM; (Shown with  
Optional SXH Standard handle)



### J36E2

230V 60Hz Motor; 30–160 RPM;  
Adjustable Variable Speed Clutch;  
Includes Standard Pitch  
Electric handle (QuickPitch™  
handle not available)



### J36H90H

Honda GX270; Centrifugal Clutch;  
90-155 RPM; Ideal for high speed  
burnishing speed reducing kit  
for panning (Lowspeed kit)



# MQ WHITEMAN

## INSTACLUTCH™ J SERIES — 36" DIAMETER

The MQ Whiteman InstaClutch™ line of walk-behind power trowels are engineered to provide the performance you expect and the reliability you depend upon. This innovative clutch system immediately disengages the drive system should the operator release the handle.

### JH55C

(shown w/ Optional QXHC  
QuickPitch™ handle)  
Honda GX160  
60-115 RPM



- **Advanced friction clutch** stops the unit within a quarter of a turn if the operator releases the handle at full RPM.
- **Eliminates the need** to throttle engine down during momentary work stoppages.
- **Four-blade spider assembly** features economically replaceable wear parts that reduce maintenance costs over the life of the machine.
- **Proven gearbox durability** delivers years of trouble-free operation.
- **Handle assemblies** for the InstaClutch system include a Standard Fine Pitch Control (SXHC) or a QuickPitch option (QXHC).

## HD-SERIES — 48" WIDTH

The MQ Whiteman HDA series trowel features a heavy-duty gearbox, CVT drive system, and a 13 HP Honda engine. With rotor speeds ranging from 35-225, this heavy duty walk behind trowel delivers the power and performance demand.



### Maximum Performance

#### HDA48413H

(Shown with QXHD QuickPitch™ handle)  
Honda GX390  
CVT (Constantly Variable Transmission)  
35-225 RPM

# MQ WHITEMAN

EDGING SERIES — 24" AND 36" WIDTH

The **MQ Whiteman edging trowels** enable the operator to finish tight to the wall without marking or marring. Easily maneuvers around obstacles. Patented ABS plastic rotating ring resists concrete build up. (J3036H55 model edger only)

## CA4HC

(shown with STHAC handle)  
Honda GX160  
70-130 RPM  
Centrifugal Clutch



## ALSO AVAILABLE

## CA4HM

Honda GX160  
70-130 RPM  
Easy operating Manual Clutch  
Includes folding QuickPitch™ handle



## J3036H55

Honda GX160  
60-115 RPM  
Centrifugal clutch.

## ADDITIONAL EDGING SERIES FEATURES:



*Allows finishing within 7/16" of any obstruction*



*Also available with QPHAFC Folding QuickPitch™ handle for easy storing (Models CA5BC and CA4HC only)*

### Use Only Original Whiteman Trowel Blades and Pans



- **Heat treated trowel steel** – for maximum wear resistance and long life
- **Greater torsional strength** – increases machine stability and produces a smoother, flatter finish
- **Enduro Blades guage steel** – to achieve up to 40% longer life than conventional trowel blades
- **Quick Change Blade system** – allows replacement of blades in minutes without the use of tools
- **Float Blades and Pans** – available for early entry conditions. Help to compact aggregate and improve flatness.

# Specifications

Model	RPM	Motor	HP (kw)*	Clutch	Operating Weight lb. (kg)	Shipping Weight lb. (kg)	Handle Options (see below)
<b>Edging Series — 24-inch (610 mm), 30-inch (762 mm), and 36-inch (914 mm) Rotating Guard Ring</b>							
CA4HM	70-130	Honda	4.8 (3.6)	Manual	171 (77.5)	204 (92.5)	Includes folding QuickPitch™ Handle
CA4HC	70-130	Honda	4.8 (3.6)	Centrifugal	145 (65.7)	164 (74.3)	STHAC; QPHAFC
J3036H55	60-115	Honda	4.8 (3.6)	Centrifugal	180 (81)	178 (70)	SXH; QXH; QXHP; SXHP
<b>J-Series — 36-inch (914 mm) Guard Ring</b>							
J36E2	30-160	230V, 60 Hz Motor	2 (1.5)	Variable Speed	166 (75)	191 (86)	Includes Standard Pitch Electric Handle
J36B65	60-115	Vanguard	6.5 (4.8)	Centrifugal	184 (83.4)	182 (82.5)	SXH; QXH; SXHP; QXHP
J36H55	60-115	Honda	4.8 (3.6)	Centrifugal	184 (83.4)	182 (82.5)	
J36H90H	90-155	Honda	8.6 (6.3)	Centrifugal	209 (94.8)	207 (93.8)	
<b>B-Series — 46-inch (1170 mm) Guard Ring</b>							
B46B90	60-130	Briggs & Stratton	8.5 (6.3)	Centrifugal	277 (125.6)	285 (129.2)	SXH; QXH; QXHP; SXHP
B46H90	60-130	Honda	8.6 (6.3)	Centrifugal	277 (125.6)	285 (129.2)	
B46H11H	90-155	Honda	9.5 (7.1)	Centrifugal	277 (125.6)	285 (129.2)	
<b>HD Series — 48-inch (1219 mm) Guard Ring</b>							
HDA48413H	35-225	Honda	11.1 (8.2)	Variable Speed	327 (148)	335 (151.9)	SXHD; QXHD; SXHDP; QXHDP
<b>INSTACLUTCH - J Series — 36-inch (914 mm)</b>							
JH55C	60-115	Honda	4.8 (3.5)	Friction	204 (92)	182 (82.5)	SXHC or QXHC

## Trowel Handle Options and Accessories

- STHAC ..... Standard knob style pitch control for CA4HC (centrifugal clutch) model
- QPHAFC ..... Folding QuickPitch™ control for CA4HC (centrifugal clutch) model
- SXH ..... Standard knob style pitch control for J- and B-Series trowels
- SXHP ..... Standard knob style pitch control for J- and B-Series trowels (includes operator present switch option)
- QXH ..... QuickPitch™ style control for J- and B-Series trowels
- QXHP ..... QuickPitch™ style control for J- and B-Series trowels (includes operator present switch option)
- SXHD ..... Standard knob style pitch control for HD-Series trowels with 2-inch diameter handle mount
- SXHDP ..... Standard knob style pitch control for HD-Series trowels with 2-inch diameter handle mount (includes operator present switch option)
- QXHD ..... QuickPitch™ style control for HD-Series trowels with 2-inch diameter handle mount
- QXHDP ..... QuickPitch™ style control for HD-Series trowels with 2-inch diameter handle mount (includes operator present switch option)

Trowel handles sold separately unless otherwise noted. All models factory equipped with combination blades.

\* Engine power ratings are calculated by the individual engine manufacturer and the rating method may vary among engine manufacturers. Multiquip Inc. and its subsidiary companies makes no claim, representation or warranty as to the power rating of the engine on this equipment and disclaims any responsibility or liability of any kind whatsoever with respect to the accuracy of the engine power rating. Users are advised to consult the engine manufacturer's owners manual and its website for specific information regarding the engine power rating.

\*\*Engines using LPG fuel should be operated only in areas with adequate ventilation. NEVER operate in confined areas or in areas where the free flow of air is restricted.

Your Multiquip dealer is:

