

PARTS MANUAL



WHITEMAN

MODELS

CA4HC

CA5BC

WALK-BEHIND TROWEL

(HONDA/VANGUARD GASOLINE ENGINE)

Revision #13 (03/21/23)

To find the latest revision of this publication or associated operation manual, visit our website at: www.multiquip.com



THIS MANUAL MUST ACCOMPANY THE EQUIPMENT AT ALL TIMES.

P/N 21769

**CA4HC/CA5BC
Walk-Behind Trowel**

Explanation Of Code In Remarks Column..... 4
Suggested Spare Parts 5

Component Drawings

Nameplate And Decals 6-7
Standard Handle Assembly 8-9
Foldable Quick-Pitch™ Handle Assembly 10-11
Basic Unit Assembly 12-13
Gearbox Assembly 14-15
Engine Assembly (Honda) 16-17
Engine Assembly (Briggs Vanguard) 18-19
Spider Assembly 20-21
Blades And Pan Assembly 22-23
Engine Service Parts (Honda) 24-25
Engine Service Parts (Vanguard) 26-27

NOTICE
Specifications and part numbers are subject to change without notice.

EXPLANATION OF CODE IN REMARKS COLUMN

The following section explains the different symbols and remarks used in the Parts section of this manual. Use the help numbers found on the back page of the manual if there are any questions.

NOTICE

The contents and part numbers listed in the parts section are subject to change **without notice**. Multiquip does not guarantee the availability of the parts listed.

SAMPLE PARTS LIST

NO.	PART NO.	PART NAME	QTY.	REMARKS
1	12345	BOLT.....	1	INCLUDES ITEMS W/%
2%		WASHER, 1/4 IN.....		NOT SOLD SEPARATELY
2%	12347	WASHER, 3/8 IN....	1	MQ-45T ONLY
3	12348	HOSE	A/R	MAKE LOCALLY
4	12349	BEARING	1	S/N 2345B AND ABOVE

NO. Column

Unique Symbols — All items with same unique symbol

(@, #, +, %, or >) in the number column belong to the same assembly or kit, which is indicated by a note in the “Remarks” column.

Duplicate Item Numbers — Duplicate numbers indicate multiple part numbers, which are in effect for the same general item, such as different size saw blade guards in use or a part that has been updated on newer versions of the same machine.

NOTICE

When ordering a part that has more than one item number listed, check the remarks column for help in determining the proper part to order.

PART NO. Column

Numbers Used — Part numbers can be indicated by a number, a blank entry, or TBD.

TBD (To Be Determined) is generally used to show a part that has not been assigned a formal part number at the time of publication.

A blank entry generally indicates that the item is not sold separately or is not sold by Multiquip. Other entries will be clarified in the “Remarks” Column.

QTY. Column

Numbers Used — Item quantity can be indicated by a number, a blank entry, or A/R.

A/R (As Required) is generally used for hoses or other parts that are sold in bulk and cut to length.

A blank entry generally indicates that the item is not sold separately. Other entries will be clarified in the “Remarks” Column.

REMARKS Column

Some of the most common notes found in the “Remarks” Column are listed below. Other additional notes needed to describe the item can also be shown.

Assembly/Kit — All items on the parts list with the same unique symbol will be included when this item is purchased.

Indicated by:

“INCLUDES ITEMS W/(unique symbol)”

Serial Number Break — Used to list an effective serial number range where a particular part is used.

Indicated by:

“S/N XXXXX AND BELOW”

“S/N XXXX AND ABOVE”

“S/N XXXX TO S/N XXX”

Specific Model Number Use — Indicates that the part is used only with the specific model number or model number variant listed. It can also be used to show a part is NOT used on a specific model or model number variant.

Indicated by:

“XXXXX ONLY”

“NOT USED ON XXXX”

“Make/Obtain Locally” — Indicates that the part can be purchased at any hardware shop or made out of available items. Examples include battery cables, shims, and certain washers and nuts.

“Not Sold Separately” — Indicates that an item cannot be purchased as a separate item and is either part of an assembly/kit that can be purchased, or is not available for sale through Multiquip.

SUGGESTED SPARE PARTS

CA4HC/CA5BC WALK-BEHIND TROWEL

1 to 3 Units

Qty.	P/N	Description
1.....	20478.....	GRIP
1.....	21046.....	GASKET KIT
1.....	21047.....	KIT, BEARING/SEAL
1.....	21718.....	PITCH CABLE (STANDARD HANDLE)
1.....	1714.....	PITCH CABLE (QPHAFC HANDLE)
1.....	21724.....	THROTTLE CABLE (STANDARD HANDLE)
1.....	21823.....	THROTTLE CABLE (QPHAFC HANDLE)
1.....	10607.....	THRUST BEARING
1.....	10567.....	THRUST COLLAR
1.....	10639.....	WEAR PLATE
3.....	2343.....	V-BELT (A-25)
2.....	10065.....	GEARBOX LUBRICANT

HONDA GX120UTQX2 GASOLINE ENGINE

1 to 3 Units

Qty.	P/N	Description
2.....	9807956846.....	SPARK PLUG
2.....	17620Z0T305.....	TANK CAP
2.....	17210ZE0505.....	AIR CLEANER ELEMENT
2.....	17218ZE0505.....	OUTER FILTER
2.....	28462ZH8003.....	ROPE, RECOIL STARTER
2.....	28461ZH8013.....	GRIP, RECOIL STARTER
2.....	15510ZE1043.....	OIL, LEVEL SW.

VANGUARD 160CC 10V3320002F1 GASOLINE ENGINE

1 to 3 Units

Qty.	P/N	Description
2.....	597383.....	SPARK PLUG
2.....	596765.....	CAP, FUEL TANK
3.....	84002309.....	FILTER, AIR
2.....	596772.....	STARTER, REWIND
2.....	597080.....	GRIP, STARTER ROPE
2.....	84004948.....	SENSOR, OIL
1.....	84004632.....	CARBURETOR

NOTICE

Part numbers on this Suggested Spare Parts list may supersede/replace the part numbers shown in the following parts lists.

NAMEPLATE AND DECALS

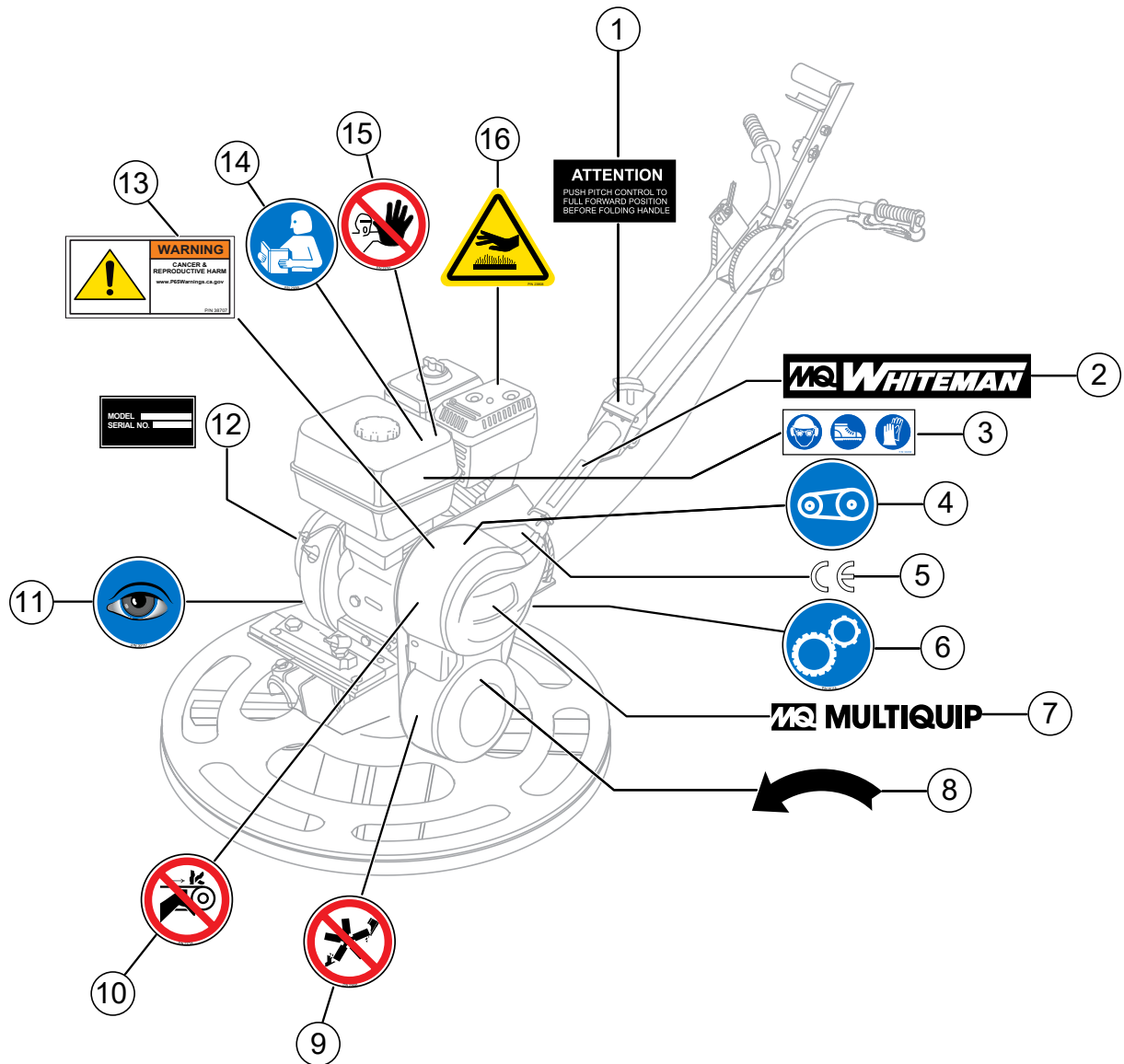

NAMEPLATE AND DECALS

<u>NO.</u>	<u>PART NO.</u>	<u>PART NAME</u>	<u>QTY.</u>	<u>REMARKS</u>
1	10732	DECAL: CAUTION PITCH HANDLE	1	
2	2942	DECAL: MQ LOGO, WHITE 13"	1	
3	36099	DECAL: PROTECTIVE CLOTHING	1	
4	32553	ISO DECAL: BELT DRIVE, 1.00" DIA.	1	
5	11092	DECAL: CE	1	
6	30118	ISO DECAL: GEAR DRIVE, 2.00" DIA.	1	
7	20816	DECAL: MQ MULTIQUIP	1	
8	25678	ISO DECAL: COUNTER CLOCKWISE	1	
9	23698	ISO DECAL: ROTATING BLADE HAZARD	1	
10	23704	DECAL: WARNING, GUARDS	1	
11	30117	ISO DECAL: EYE, INSPECTION	1	
12		NAME PLATE	1.....	CONTACT MULTIQUIP PARTS DEPARTMENT
13	38707	ISO DECAL: PROP 65	1	
14	23699	ISO DECAL: READ MANUAL	1	
15	23701	ISO DECAL: ASK FOR TRAINING	1	
16	23808	ISO DECAL: HOT SURFACE HAZARD	1	

STANDARD HANDLE ASSY.

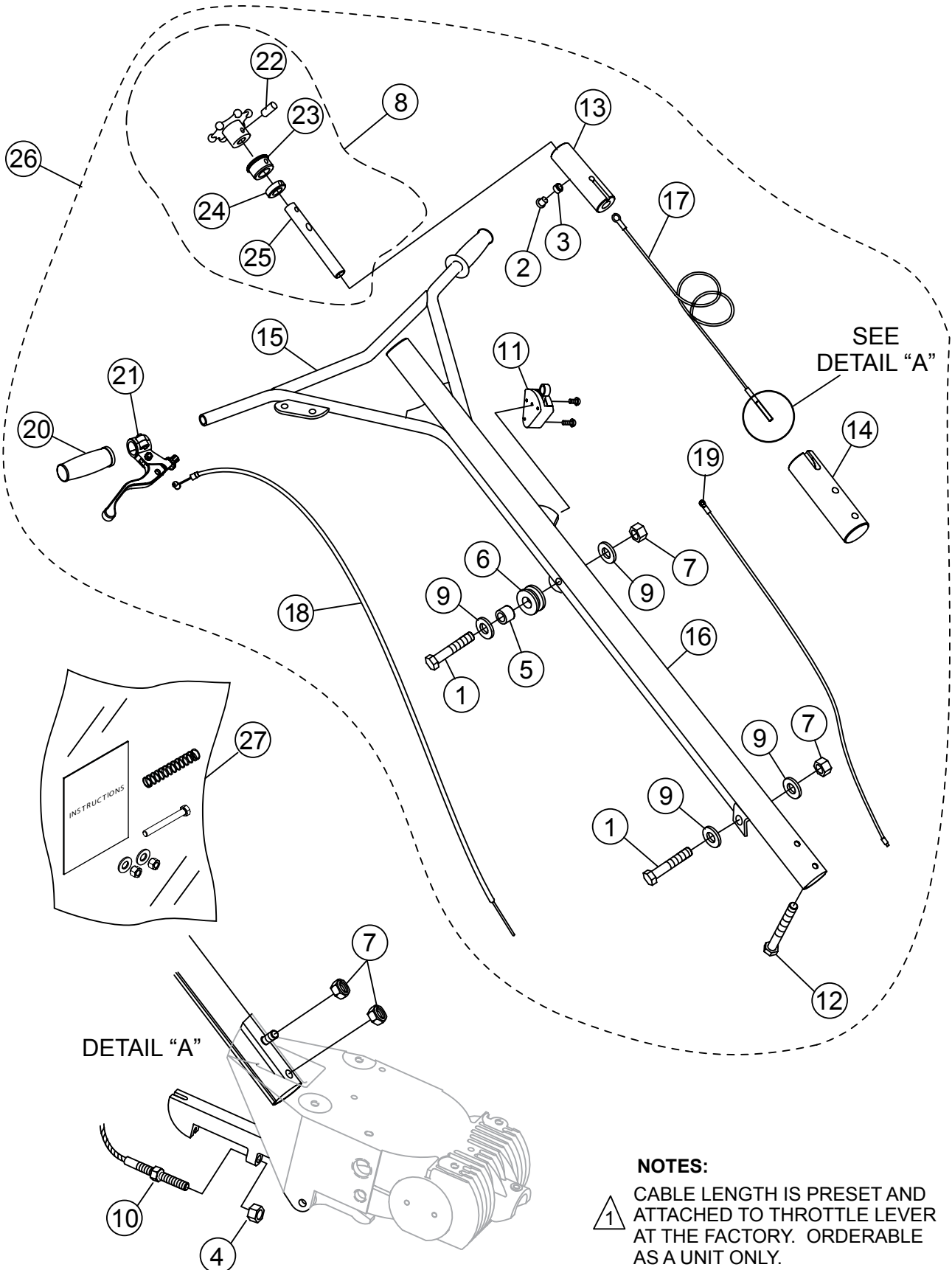

NOTES:

1 CABLE LENGTH IS PRESET AND ATTACHED TO THROTTLE LEVER AT THE FACTORY. ORDERABLE AS A UNIT ONLY.

STANDARD HANDLE ASSY.

<u>NO.</u>	<u>PART NO.</u>	<u>PART NAME</u>	<u>QTY.</u>	<u>REMARKS</u>
1@	0169	SCREW, HHC 3/8-16 X 3	2	
2@	0786	SCREW, BHC 1/4-20 X 3/8 NYL PATCH ,NP	2	
3@	0786 A	SPACER, SLIDE BLOCK GUIDE, .360 X 17/64 X 1/8L	1	
4@	1116	NUT, BRASS JAM 5/16-18	1	
5@	1245	BUSHING, GUARD RING	1	
6@	1247	GROMMET, 1/4 x .875 ID x 1-5/8 OD	1	
7@	10133	NUT, NYLOC 3/8-16	2	
8@	21279	HAND WHEEL ASSEMBLY, PITCH CONTROL ...	1	INCLUDES ITEMS W/*
9@	10136	WASHER, FLAT SAE 3/8	4	
10@	10698	NUT, 5/16-18 CONICAL	1	
11@	20856	SWITCH ASM., KILL	1	
12@	21017	SCREW, HHC 3/8-16 x 3.25 FULL THRD GR5	1	
13@	21249	SLIDE BLOCK, TROWEL CONTROL	1	
14@	21250	BLOCK SUPPORT	1	
15@	21251-1	HANDLE, ISO W/A, WHITEMAN FIN	1	
16@	21254-1	HANDLE, W/A, WHITEMAN FIN	1	
17@	21718	CABLE, CONTROL	1	
18@	21724	CABLE ASSY., HANDLE THROTTLE	1	
19@	21953	HARNESS, PRESENCE SWITCH, 43.25"	1	
20@	22762	GRIP, HANDLE, 0.875	2	
21@	391512	LEVER, HAND CLUTCH CONTROL, METAL	1	
22*@	1729	PIN, ROLL 3/16 X 1-1/4	1	
23*@	21248	BEARING, TROWEL CONTROL	1	
24*@	3615	COLLAR, SET 3/4 ID	1	
25*@	21282	SHAFT, PITCH CONTROL	1	
26	STHAC	HANDLE ASSY.	1	INCLUDES ITEMS W/@ CONTACT UNIT SALES DEPT.
27	22100	KIT, INSTALLATION, VIB. CONTRL. HANDLE	1	

FOLDABLE QUICK-PITCH™ HANDLE ASSY.

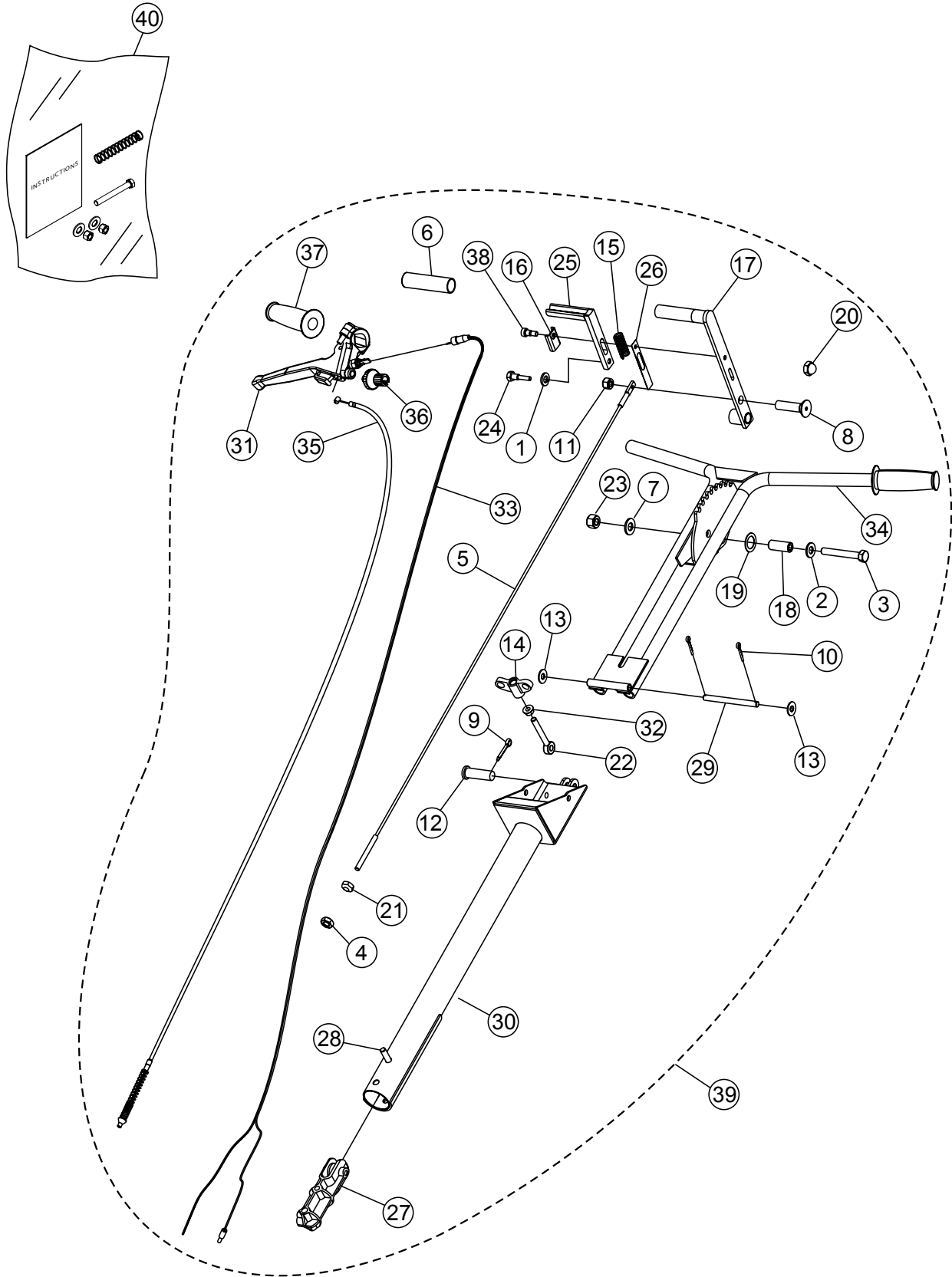

FOLDABLE QUICK-PITCH™ HANDLE ASSY.

<u>NO.</u>	<u>PART NO.</u>	<u>PART NAME</u>	<u>QTY.</u>	<u>REMARKS</u>
1*	0161 C	WASHER, LOCK 5/16 MED.....	1	
2*	0300 B	WASHER, FLAT SAE 5/16	2	
3*	0669 A	SCREW, HHC 5/16 - 18 X 2-1/4	1	
4*	1116	NUT, BRASS JAM 5/16-18	1	
5*	1714	CABLE, PITCH CONTROL	1	
6*	1724	GRIP, HANDLE PITCH	1	
7*	2942	DECAL, MQ WHITEMAN 13" WHITE	1	
8*	3164	SCREW, FHSC 1/4 - 20 X 1/2 NO PLATE	1	
9*	3216	PIN, COTTER 1/8D X 1.00	1	
10*	5117	PIN, COTTER 1/16D X 1/2	2	
11*	5283	NUT, NYLOC 5/16-18	2	
12*	5291	PIN, CLEVIS 3/8 X 1-1/8	1	
13*	10136	WASHER, FLAT 3/8 SAE	2	
14*	10651	TEE HANDLE	1	
15*	10654	SPRING, LATCH RETURN	1	
16*	10655	COVER, SPRING	1	
17*	10657	CONTROL HANDLE	1	
18*	10658	TUBE, CONTROL HANDLE SUPPORT	1	
19*	10660	SHIM, 1.125 O.D. X .75 I.D. X .031	1	
20*	10676	NUT, ACORN 5/16 - 18	1	
21*	10698	NUT, 5/16 - 18 - CONICAL	1	
22*	10701	BOLT, SWING	1	
23*	10732	DECAL, FOLDING HANDLE	1	
24*	10878	BOLT, QP LATCHING	1	
25*	10881	LATCHING BAR	1	
26*	11015	STRIP, HANDLE SPACER	1	
27*	20280	BLOCK, PITCH CONTROL	1	
28*	21017	SCREW, HHC 3/8-16 X 3 1/4 FULL THRD GR 5	1	
29*	21758	PIN, HINGE HANDLE	1	
30*	21779	HANDLE, LOWER	1	
31*	21780	THROTTLE, MAGURA MODEL 90 W/KILL SW	1	
32*	21781	NUT, FLG'D HEX 3/8 - 16 PLTD	1	
33*	21785	KILL SWITCH HARNESS, MAGURA MODEL 90	1	
34*	21788	HANDLE, UPPER	1	
35*	21823	CABLE, MAGURA MODEL 90 CONTROL LEVER	1	
36*	21824	ADJUSTER, W/THUMB WHEEL	1	
37*	22762	GRIP, HANDLE, 0.875	2	
38*	3910382	SCREW, SHDLR, 3/8D X 3/8L, 5/16-1 SCKT HD	1	
39	21786	FOLDABLE HANDLE ASSY., QPHAFC.....	1	INCLUDES ITEMS W/*
40	22100	KIT, INSTALLATION, VIB. CONTRL. HANDLE	1	

BASIC UNIT ASSY.

SEE QUICK PITCH
HANDLE ASSY. ITEM 5.

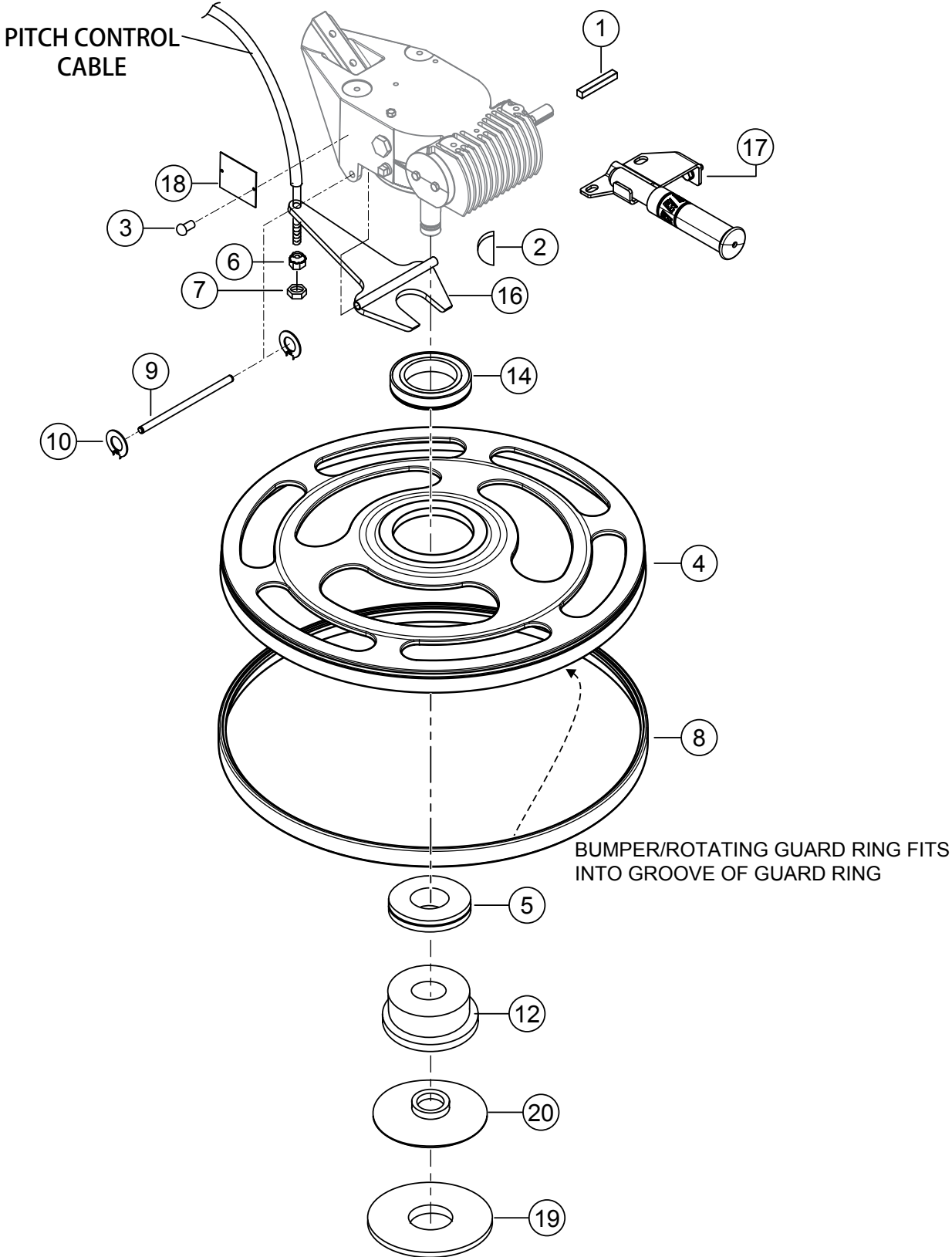

BASIC UNIT ASSY.

<u>NO.</u>	<u>PART NO.</u>	<u>PART NAME</u>	<u>QTY.</u>	<u>REMARKS</u>
1	0627	KEY, 3/16" X 1-1/4"	1	
2	1139	KEY, WOODRUFF 1/4 X 1-1/4" (#21) HRDND	1	
3	4014	SCREW, 2-3/16" P-K TYPE U DRIVE	2	
4	21433	RING, ROTAINING GUARD	1	
5	10607	BEARING, THRUST 6207, SEALED BOTH SIDES	1	
6	10698	NUT, ADJUSTING 5/16-18	1	
7	1116	NUT, BRASS JAM 5/16-18	1	
8	24304	BUMPER	1	
9	20801	PIN, YOKE	1	
10	20802	RING, SNAP, TRUARC 5100-37	2	
11	21433	RING, ROTATING GUARD	1	
12	21434	SLEEVE, PITCH	1	
14	21441	BEARING, 2.9375" I.D. 4.527" O.D.	1	
15	24304	BUMPER, 24" ROTATING GUARD RING	1	
16	21477	YOKE W/A, CA4	1	
17	22673	LIFT BRACKET ASSY., CA4	1	
18		SERIAL PLATE	1CONTACT MQ PARTS DEPT.
19	10639	WEAR PLATE	1	
20	10567	THRUST COLLAR	1	

GEARBOX ASSY.

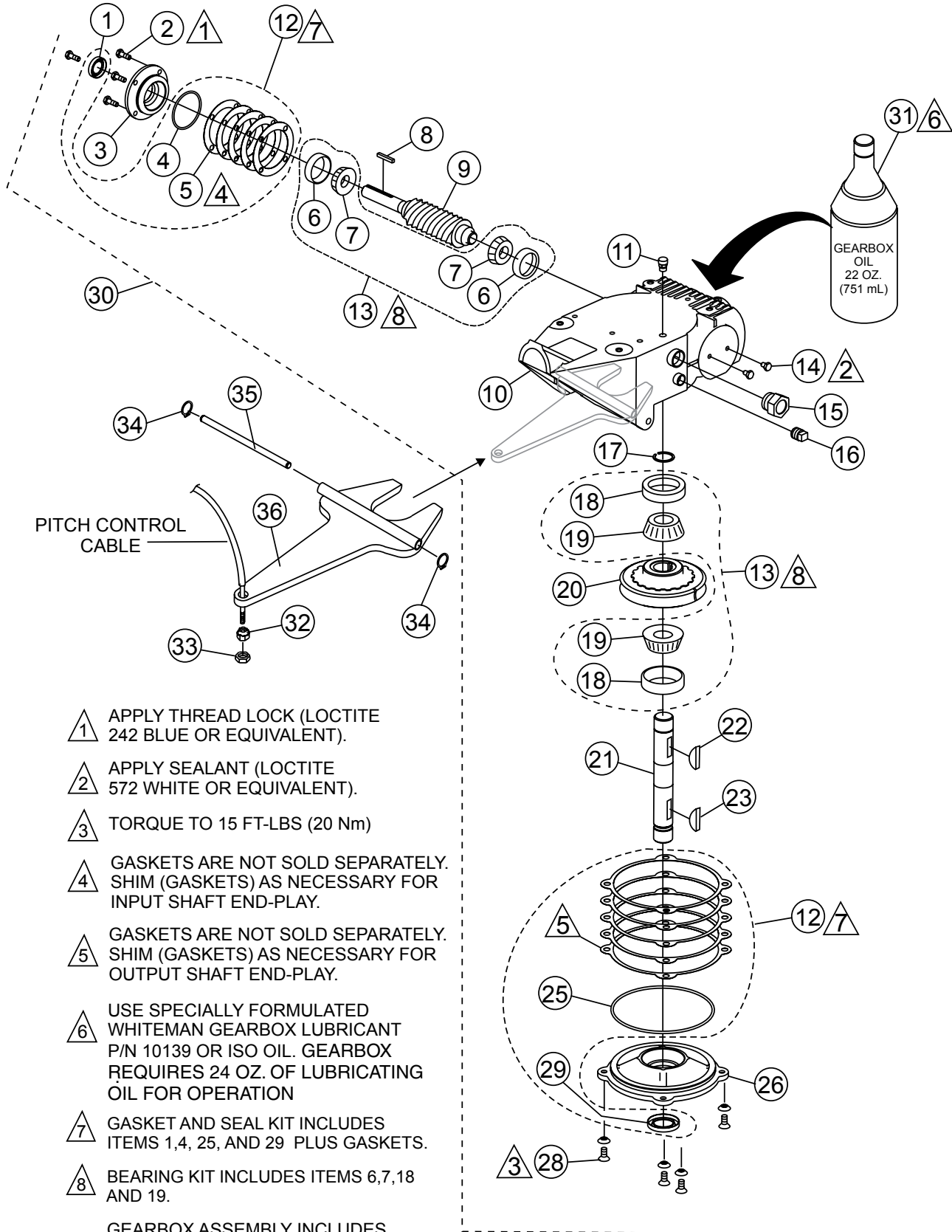

- ▲ 1 APPLY THREAD LOCK (LOCTITE 242 BLUE OR EQUIVALENT).
- ▲ 2 APPLY SEALANT (LOCTITE 572 WHITE OR EQUIVALENT).
- ▲ 3 TORQUE TO 15 FT-LBS (20 Nm)
- ▲ 4 GASKETS ARE NOT SOLD SEPARATELY. SHIM (GASKETS) AS NECESSARY FOR INPUT SHAFT END-PLAY.
- ▲ 5 GASKETS ARE NOT SOLD SEPARATELY. SHIM (GASKETS) AS NECESSARY FOR OUTPUT SHAFT END-PLAY.
- ▲ 6 USE SPECIALLY FORMULATED WHITEMAN GEARBOX LUBRICANT P/N 10139 OR ISO OIL. GEARBOX REQUIRES 24 OZ. OF LUBRICATING OIL FOR OPERATION
- ▲ 7 GASKET AND SEAL KIT INCLUDES ITEMS 1,4, 25, AND 29 PLUS GASKETS.
- ▲ 8 BEARING KIT INCLUDES ITEMS 6,7,18 AND 19.
- ▲ 9 GEARBOX ASSEMBLY INCLUDES ITEMS WITHIN DASHED LINE EXCEPT ITEMS 12,13 AND 31

GEARBOX ASSY.

<u>NO.</u>	<u>PART NO.</u>	<u>PART NAME</u>	<u>QTY.</u>	<u>REMARKS</u>
1%*	0753	SEAL, OIL NATIONAL	1	
2%	0131 A	SCREW, HHC 1/4-20 X 3/4	4	
3%	12876	FLANGE, INPUT SHAFT	1	
4%*	20395	RING, O -2" BUNA N	1	
6%#	20466	BEARING, CUP, TIMKEN	2	
7%#	20465	BEARING, CONE, TIMKEN	2	
8%	0627	KEY, SQUARE 3/16 X 1 1/4	1	
9%	1851	GEAR, WORM & SHAFT ASSY.	1	
10%	12874	CASE, GEAR WORM MACHINED	1	
11%	21218	VENT, AIR	1	
12	21046	GASKET/SEAL KIT.....	1	INCLUDES ITEMS W/*
13	21047	KIT, BEARING/SEAL.....	1	INCLUDES ITEMS W/#
14%	20476	SCREW, HHC 1/4-28 X 3/8	2	
15%	21033	SIGHT GLASS, 3/4 NPT STEEL-NO BALL	1	
16%	0121 A	FITTING, PLUG 3/8 MP SQ HEAD	1	
17%	1138	RING, SNAP, TRUARC 5100-112	1	
18%#	20475	BEARING, CUP TIMKEN	2	
19%#	20474	BEARING, CONE TIMKEN	2	
20%	1140	GEAR, WORM, COMPOSITE	1	
21%	21435	SHAFT, OUTPUT	1	
22%	1139	KEY, WOODRUFF #810 HARDENED	1	
23%	1139	KEY, WOODRUFF #810 HARDENED	1	
26%	12875	COVER, GEARBOX	1	
25%	20396	O-RING, 254 BUNA N	1	
27%	10235	WASHER, C/S EXT. SHKP	4	
28%	20875	SCREW, FHSC 5/16-18 X 3/4	4	
29%*	0254	SEAL, OIL, NATIONAL	1	
30	21436	GEARBOX ASSY.	1	INCLUDES ITEMS W/%
31	20111	LUBE, GEARBOX OIL ISO 680 22 OZ (650 ML)..	2	REQUIRES 20 OZ.
32	10698	NUT, ADJUSTING 5/16-18	1	
33	1116	NUT, BRASS JAM 5/16-18	1	
34	20802	SNAP RING	2	
35	20801	YOKE PIN	1	
36	21477	YOKE	1	

ENGINE ASSY. (HONDA)

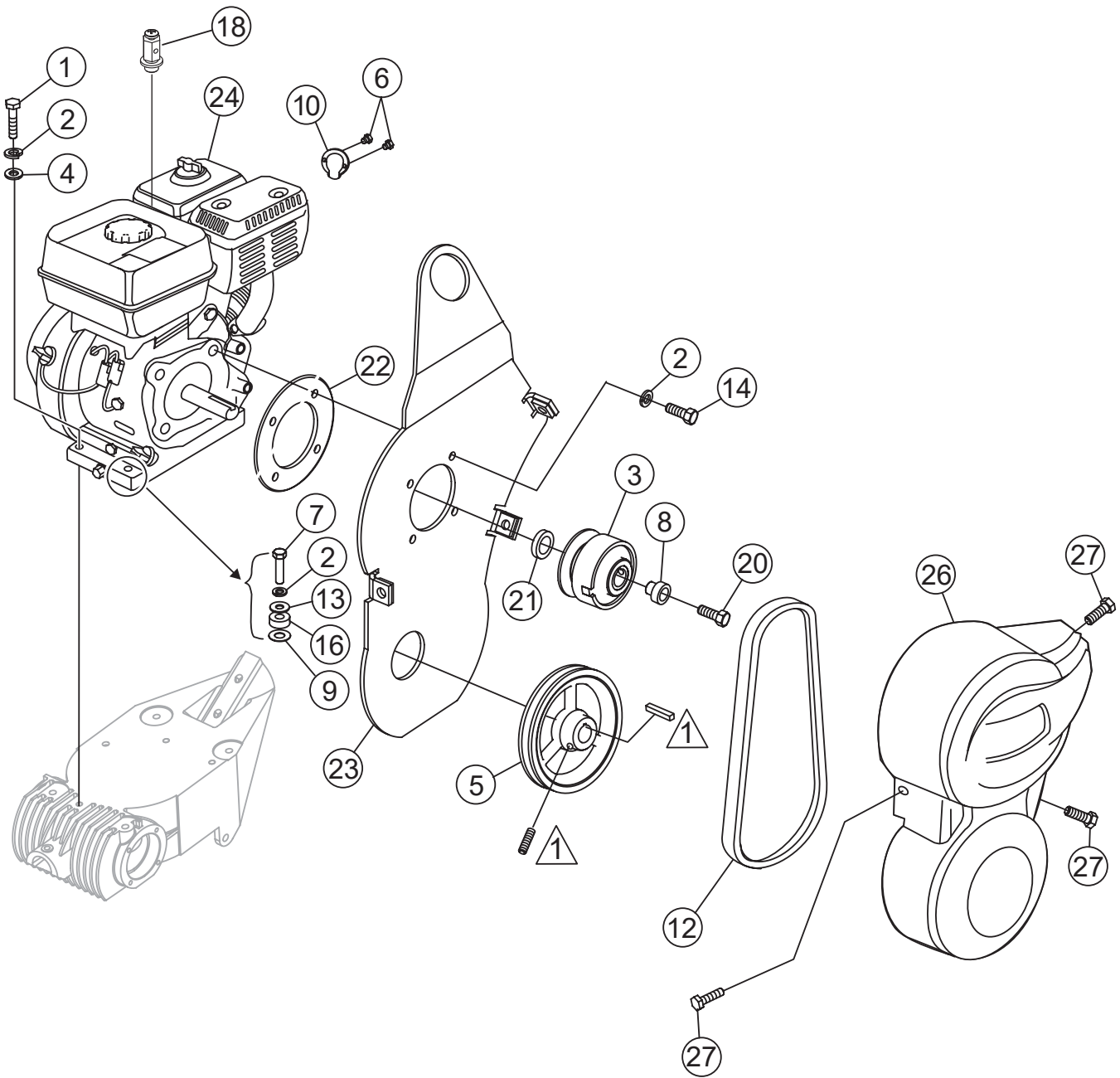

NOTES:

 COMES WITH PULLEY.

ENGINE ASSY. (HONDA)

<u>NO.</u>	<u>PART NO.</u>	<u>PART NAME</u>	<u>QTY.</u>	<u>REMARKS</u>
1	0105	SCREW, HHC 5/16- 18 X 1-1/2	3	
2	0161 C	LOCK WASHER 5/16	7	
3	0255	CLUTCH ASSEMBLY	1	
4	0300 B	FLAT WASHER 5/16	3	
5	0740	PULLEY AK-51 X 3/4	1	
6	1273	SCREW, HHST 3- 32 X 3/8	2	
7	1284	SCREW, HHC 3/8 -16 X 1-1/2	1	
8	1406	END PLUG, CLUTCH	1	
9	1733	WASHER, 1/2 X 1/32	1	
10	1834	DEFLECTOR, HONDA EXHAUST	1	
12	2343	V-BELT, A-25	1	
13	10136	FLAT WASHER 3/8	1	
14	10229	SCREW, HHC 5/16-24 X 1"	4	
16	13351	WASHER, FLAT 3/8 EXT THICK HIGH STRGTH	1	
18	20845	SWIVEL ASSY., THROTTLE CABLE	1	
20	21678	SCREW, FHSC 5/16 - 24 X 1-3/4	1	
21	21679	SPACER, 1" X .78 X 69L	1	
22	21915	SPACER, C AND J LIFTING BALE	1	
23	21927	BRACKET, W/LIFTING BALE ASSY.	1	
24	22900	ENGINE, HONDA GX120 TIER 3 (3.5 HP)	1	
26	30102-00	BELT GUARD, TROWEL	1	
27	30119	SCREW, 1/4-20X7/8"	3	

ENGINE ASSY. (VANGUARD)

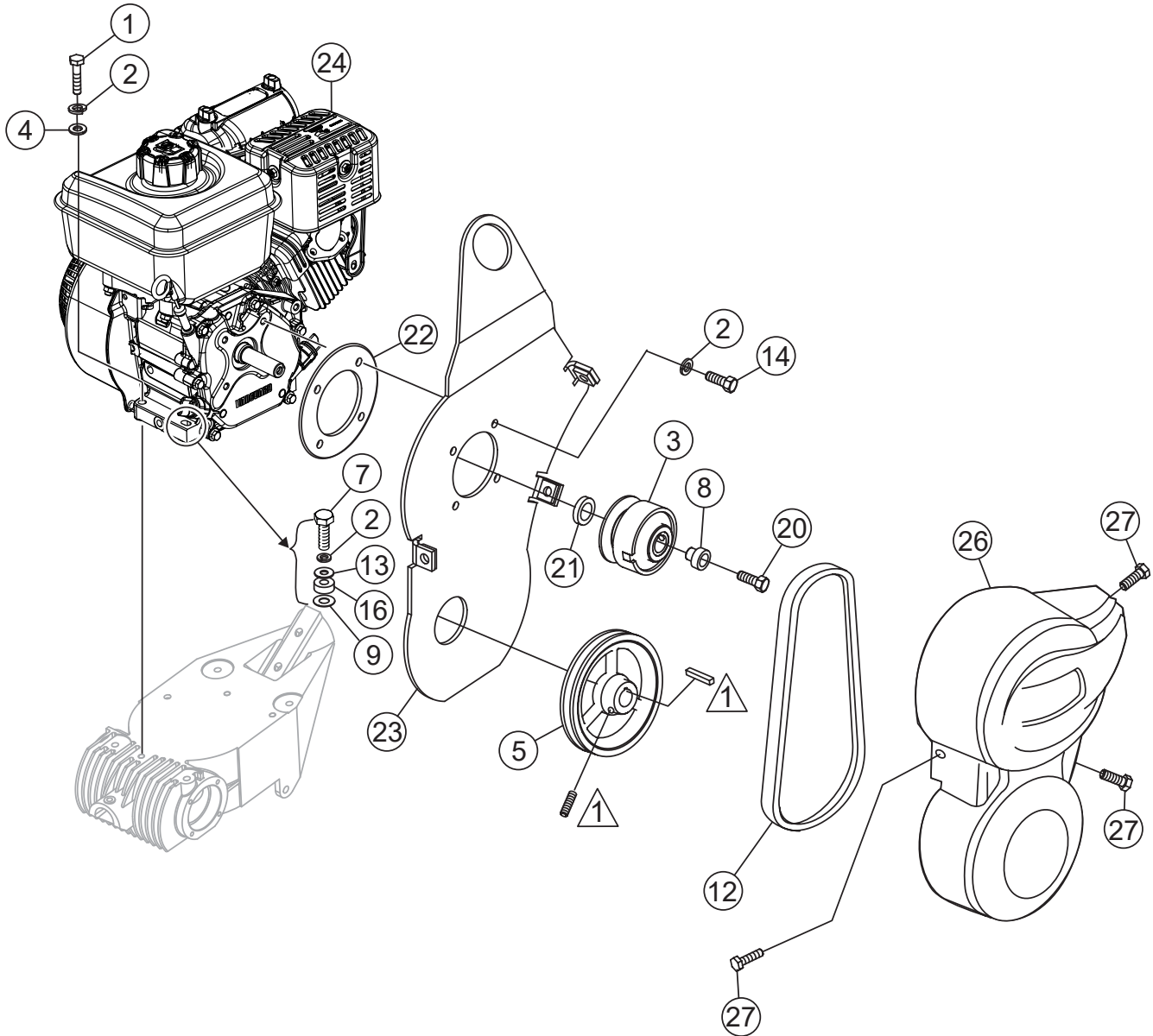

NOTES:

△ COMES WITH PULLEY.

ENGINE ASSY. (VANGUARD)

<u>NO.</u>	<u>PART NO.</u>	<u>PART NAME</u>	<u>QTY.</u>	<u>REMARKS</u>
1	0105	SCREW, HHC 5/16- 18 X 1-1/2	3	
2	0161 C	LOCK WASHER 5/16	7	
3	0255	CLUTCH ASSEMBLY	1	
4	0300 B	FLAT WASHER 5/16	3	
5	0740	PULLEY AK-51 X 3/4	1	
7	1284	SCREW, HHC 3/8 -16 X 1-1/2	1	
8	1406	END PLUG, CLUTCH	1	
9	1733	WASHER, 1/2 X 1/32	1	
12	2343	V-BELT, A-25	1	
13	10136	FLAT WASHER 3/8	1	
14	10229	SCREW, HHC 5/16-24 X 1"	4	
16	13351	WASHER, FLAT 3/8 EXT THICK HIGH STRGTH	1	
18	20845	SWIVEL ASSY., THROTTLE CABLE	1	
20	21678	SCREW, FHSC 5/16 - 24 X 1-3/4	1	
21	21679	SPACER, 1" X .78 X 69L	1	
22	21915	SPACER, C AND J LIFTING BALE	1	
23	21927	BRACKET, W/LIFTING BALE ASSY.	1	
24	48170	ENGINE, VANGUARD 160CC	1	
26	30102-001	BELT GUARD, TROWEL	1	
27	30119	SCREW, 1/4-20X7/8"	3	

SPIDER ASSY.

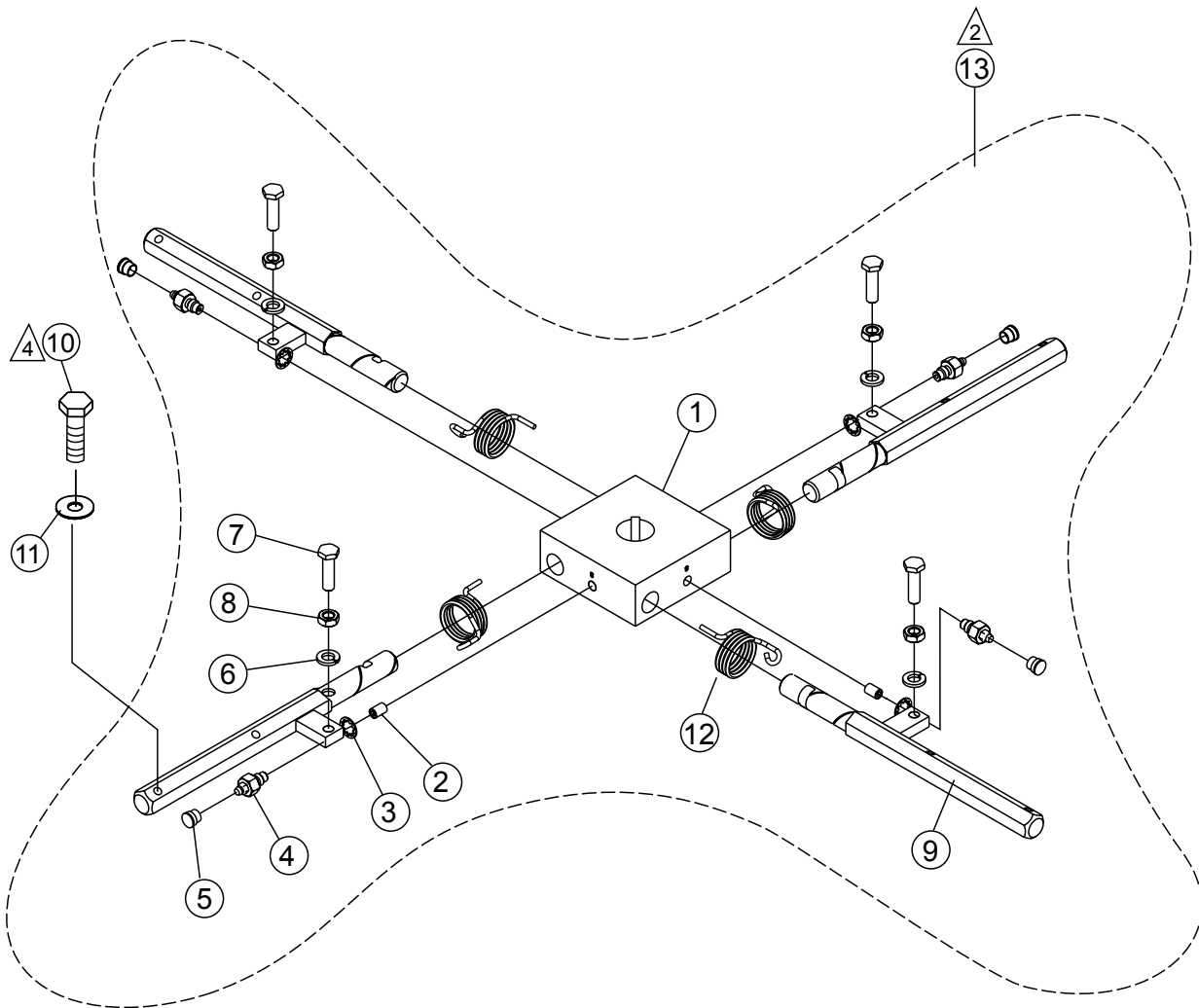

NOTES:

① APPLY LOCTITE P/N 1477 TO ITEMS 1.

② SPIDER ASSEMBLY P/N 11860
INCLUDES ALL ITEMS WITHIN OUTLINE.

③ INCLUDED WITH ITEM 15 OR CAN BE
ORDERED SEPARATELY (P/N 1471)

④ TORQUE TO 130 FT.-LBS (176 Nm)

SPIDER ASSY.

<u>NO.</u>	<u>PART NO.</u>	<u>PART NAME</u>	<u>QTY.</u>	<u>REMARKS</u>
1#	10563	SPIDER PLATE, 1-1/8 SHAFT 4BLD CA4	1	
2#	11299	SCREW, SHS 5/16-18 X 9/16 CONE PT	2	
3#	1875	WASHER, INT. SHKP, 3/8	4	
4#	10587	ARM RETAINING ASSY., SHORT	4	
5#	1162 A	CAP, GREASE ZERK #2 YELLOW	4	
6#	0166 A	WASHER, LOCK, 3/8 MED.	4	
7#	0164 B	SCREW, TROWEL ADJUSTMENT 3/8-16	4	
8#	1876	NUT, HEX JAM 3/8-16 CLASS 2B	4	
9#	10768	ARM, TROWEL W/A	4	
10	10790	SCREW, HHC M6- 1 X 30MM	8	
11	0181 B	LOCK WASHER 1/4"	8	
12#	30148	SPRING, TROWEL ARM CA4	4	
13	11860	SPIDER ASSY.....	1.....	INCLUDES ITEMS W/#

BLADES AND PAN ASSY.

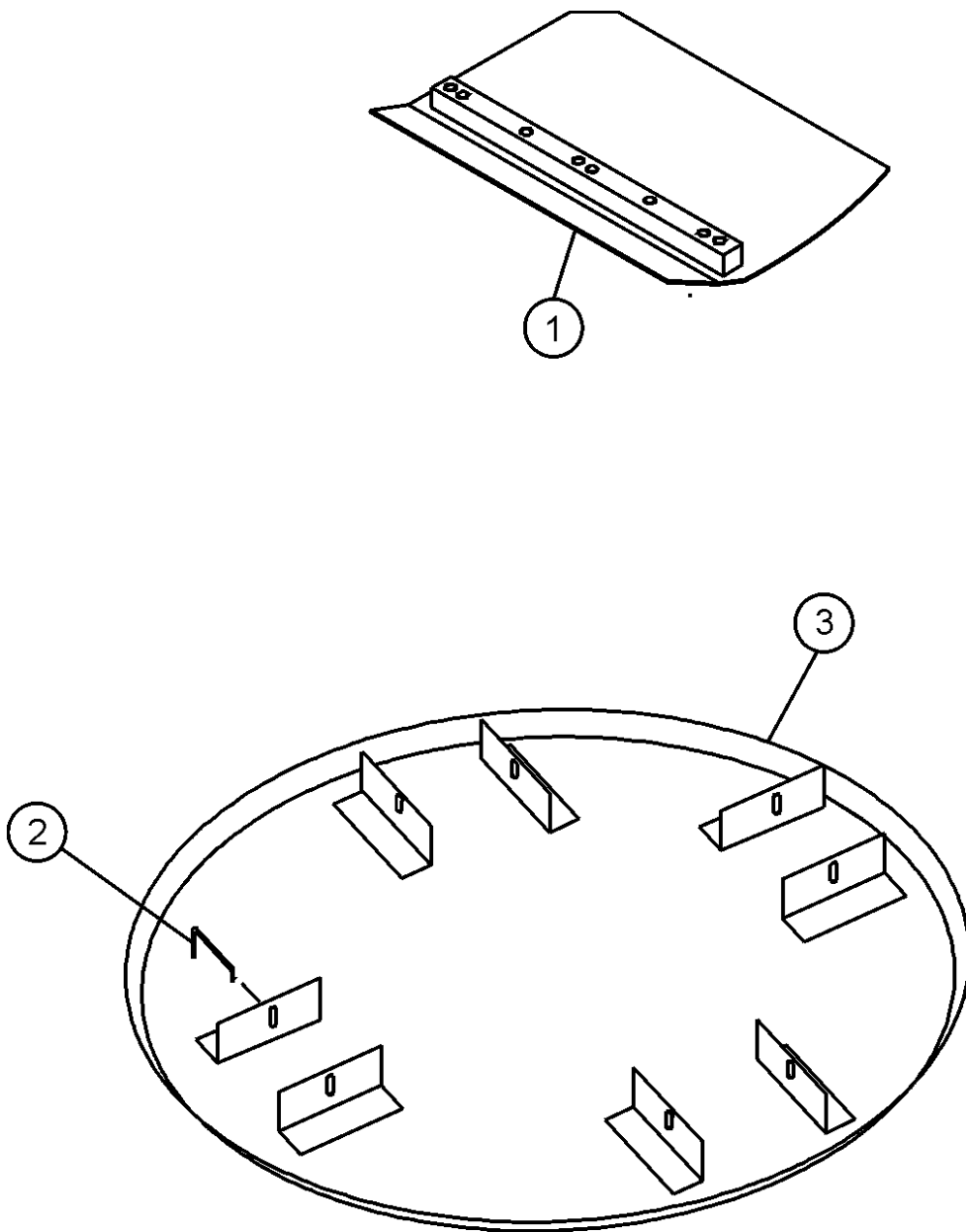

BLADES AND PAN ASSY.

<u>NO.</u>	<u>PART NO.</u>	<u>PART NAME</u>	<u>QTY.</u>	<u>REMARKS</u>
1		COMBO FLOAT & FINISH BLADE	4.....	CONTACT UNIT SALES DEPT./ ACCESSORY ITEM
2		FLOAT DISC LATCH PIN.....	4.....	CONTACT UNIT SALES DEPT./ ACCESSORY ITEM
3		FLOAT DISC	1.....	CONTACT UNIT SALES DEPT./ ACCESSORY ITEM

ENGINE SERVICE PARTS (HONDA)

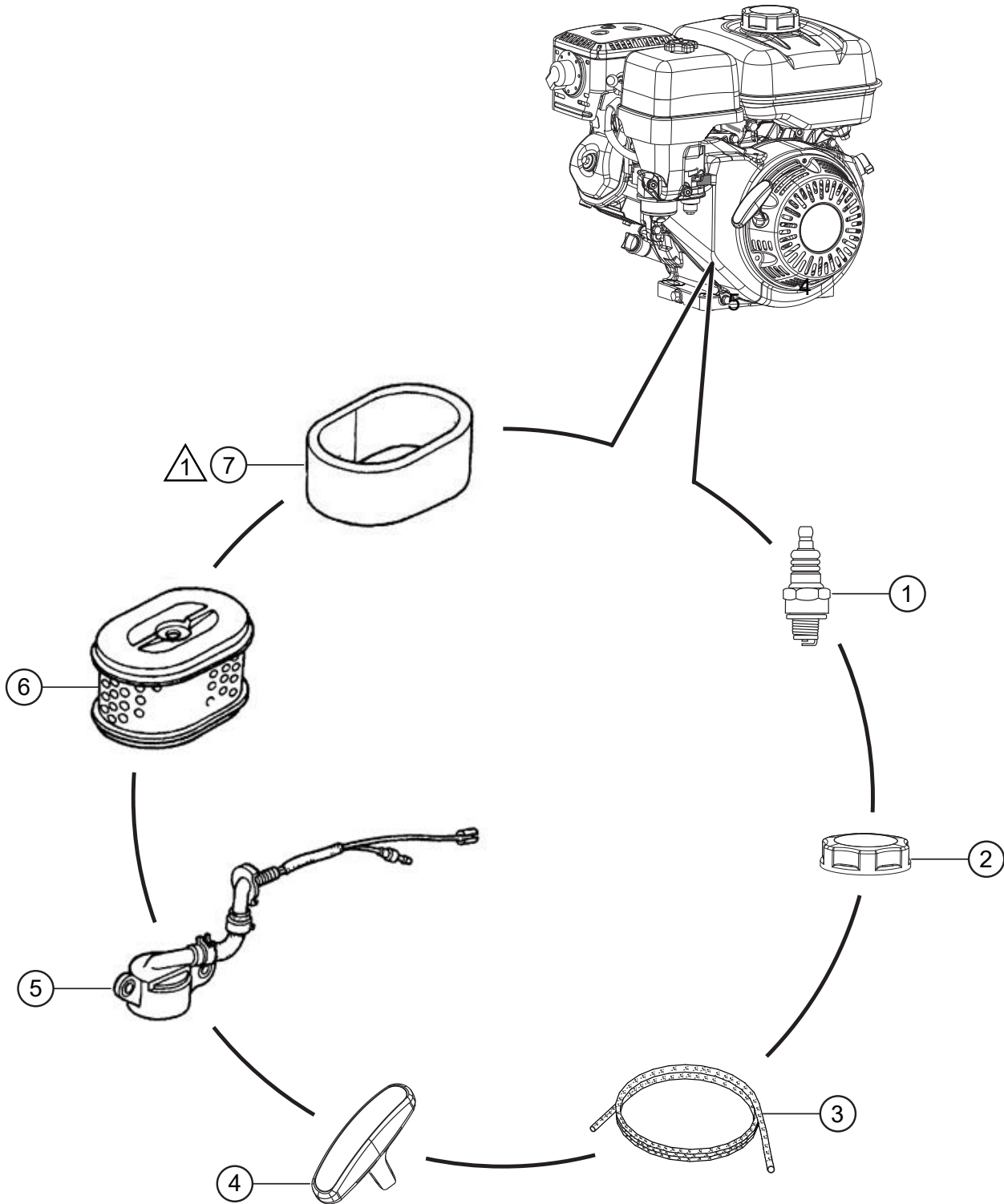

NOTES:

① INCLUDED WITH ITEM 7.

ENGINE SERVICE PARTS (HONDA)

<u>NO.</u>	<u>PART NO.</u>	<u>PART NAME</u>	<u>QTY.</u>	<u>REMARKS</u>
1	9807956846	SPARK PLUG	1	
2	17620Z0T305	TANK CAP W/ GASKET	1	
3	28462ZH8003	ROPE, RECOIL STARTER	1	
4	28461ZH8013	GRIP, RECOIL STARTER	1	
5	15510ZE1043	OIL LEVEL SWITCH	1	
6	17210ZE0505	AIR CLEANER ELEMENT	1.....	INCLUDES ITEMS W/#
7#	17218ZE0505	OUTER FILTER	1	

ENGINE SERVICE PARTS (VANGUARD)

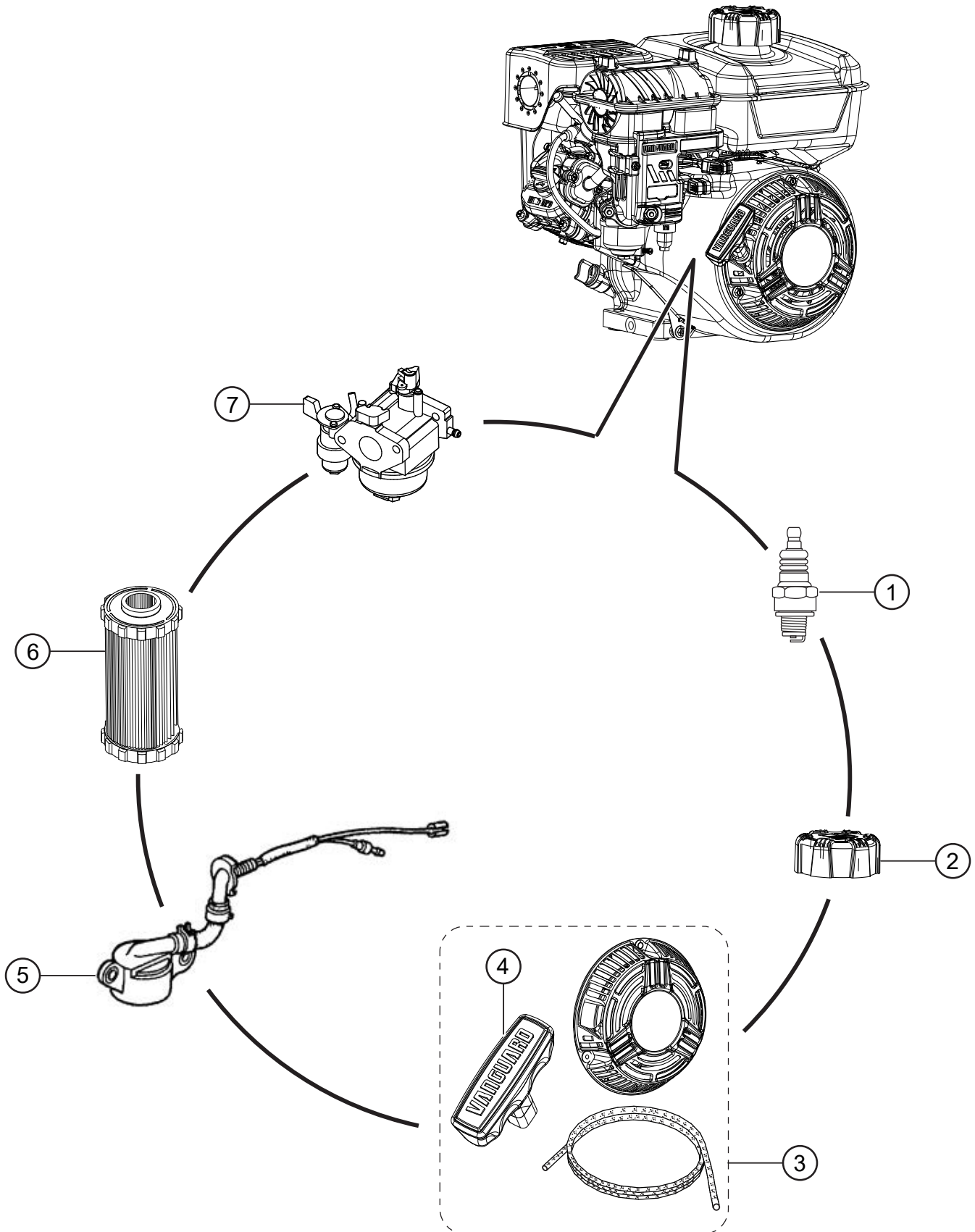

ENGINE SERVICE PARTS (VANGUARD)

<u>NO.</u>	<u>PART NO.</u>	<u>PART NAME</u>	<u>QTY.</u>	<u>REMARKS</u>
1	597383	SPARK PLUG	1	
2	596765	CAP, FUEL TANK	1	
3	596772	STARTER, REWIND.....	1.....	INCLUDES ITEMS W/#
4#	597080	GRIP, STARTER ROPE	1	
5	84004948	SENSOR, OIL	1	
6	84002309	FILTER, AIR	1	
7	84004632	CARBURETOR	1	

PARTS MANUAL

HERE'S HOW TO GET HELP

PLEASE HAVE THE MODEL AND SERIAL
NUMBER ON-HAND WHEN CALLING

United States

Multiquip Inc.

(310) 537- 3700
6141 Katella Avenue Suite 200
Cypress, CA 90630
E-MAIL: mq@multiquip.com
WEBSITE: www.multiquip.com

Canada

Multiquip

(450) 625-2244
4110 Industriel Boul.
Laval, Quebec, Canada H7L 6V3
E-MAIL: infocanada@multiquip.com

United Kingdom

Multiquip (UK) Limited Head Office

0161 339 2223
Unit 2, Northpoint Industrial Estate, Globe Lane,
Dukinfield, Cheshire SK16 4UJ
E-MAIL: sales@multiquip.co.uk

© COPYRIGHT 2023, MULTIQUIP INC.

Multiquip Inc, the MQ logo are registered trademarks of Multiquip Inc. and may not be used, reproduced, or altered without written permission. All other trademarks are the property of their respective owners and used with permission.

This manual MUST accompany the equipment at all times. This manual is considered a permanent part of the equipment and should remain with the unit if resold.

The information and specifications included in this publication were in effect at the time of approval for printing. Illustrations, descriptions, references and technical data contained in this manual are for guidance only and may not be considered as binding. Multiquip Inc. reserves the right to discontinue or change specifications, design or the information published in this publication at any time without notice and without incurring any obligations.



P/N 21769