



DA7000SSA3

Generator

WhisperWatt™

Prime Rating — 6 kW (6 kVA)

Standby Rating — 7 kW (7 kVA)

Single-Phase, 60 Hertz, 1.0 PF

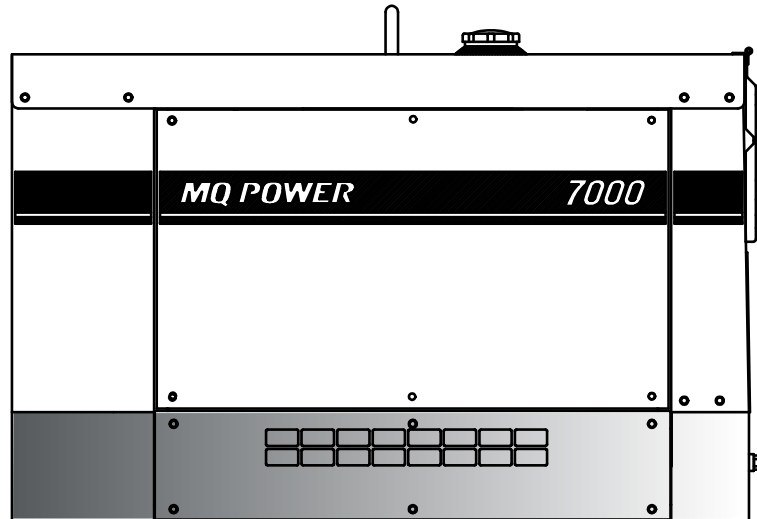

STANDARD FEATURES

- Heavy duty, 4-cycle, liquid-cooled diesel engine provides maximum reliability.
- EPA emissions certified — Tier 4 Final emissions compliant.
- Single-side Maintenance Design — Quick, direct access to all filters. External fluid drain extensions allow fast, easy service. Ideal for Ground Heater applications and confined areas.
- Automatic safety shutdown system — Monitors low oil pressure, high water temperature and battery charge via warning lamp display module.
- Excellent voltage regulation — Power is controlled within $\pm 2.5\%$ of mean voltage. Self-regulated.
- Full load acceptance of standby nameplate rating in a single step.
- Sound attenuated, weather resistant, steel housing provides operation at 65 dB(A) at 23 feet. Fully lockable enclosure allows safe unattended operation.
- E-coat primer with polyurethane enamel finish coat.
- Internal fuel tank — Holds 6.6 gallons (25 liters).
- Brushless Generator Design — Reduces services and maintenance requirements.
- Complete power panel — Fully covered single phase receptacles allow fast and convenient hookup for most applications including temporary power boxes, tools and lighting equipment. All are NEMA standard.
- Complete generator instrumentation — Includes 2-pole GFCI circuit breaker, AC voltmeter, hour meter, idle control switch, full power switch, warning lamp display, and ignition switch.
- Main Line Circuit Breaker — Provides full panel GFCI protection, OSHA and NEC compliant, 25 Amp rating.



DA7000SSA3

Generator

SPECIFICATIONS

Generator Specifications	
Design	Revolving field, self-ventilated drip-proof, single bearing
Armature Connection	Series
Excitation	Solid State, Statically Excited System
Phase	Single Phase (3-wire)
Standby Output	7 KW (7 KVA)
Prime Output	6 KW (6 KVA)
Rated Voltage	120/240V
Power Factor	1.0
Voltage Regulation (No load to full load)	±2.5%
Generator RPM	3600
Frequency	60 Hz
Winding Pitch	11/16
No. of Poles	2
No. of Leads	4
Frequency Regulation: No Load to Full Load	3-5% under varying loads from no load to 100% rated load
Frequency Regulation: Steady State	±2.5% of mean value for constant loads from no load to full load
Insulation	Class F
Sound Level dB(A) Full load at 23 feet	65

Engine Specifications	
Make / Model	Kubota / Z482-E3B
Emissions	EPA Tier 4 Final Certified
Starting System	Electric
Design	Vertical, 4-cycle, liquid cooled, diesel engine
Displacement	29.23 in ³ (479 cc)
No. cylinders	2
Bore x Stroke	2.52 x 2.68 in. (64 x 68 mm)
Gross Engine Power Output	12.5 hp (9.3 kW)
Compression Ratio	23:1
Engine Speed	3600 rpm
Oil Capacity	.66 gallons (2.5 liters)
Coolant Capacity	.74 gallons (2.8 liters)
Starting System	Electric
Battery	12V 35Ah x 1

Fuel System		
Recommended Fuel	ASTM-D975-No.1 & No.2-D*	
Fuel Tank Capacity	6.6 gallons (25 liters)	
Fuel Consumption	gph	lph
At full load	0.69	2.6
At 3/4 load	0.55	2.1
At 1/2 load	0.48	1.8
At 1/4 load	0.37	1.4

* - Use ultra-low sulfur diesel fuel.

Amperage	
Rated Voltage	Amps
120 Volt	58.3 Max
120 Volt	50 Continuous
240 Volt	29.2 Max
240 Volt	25 Continuous

WARRANTY*

Kubota Engine

12 months from date of purchase with unlimited hours or 24 months from date of purchase with 2000 hours (whichever occurs first).

Generator

24 months from date of purchase or 2000 hours (whichever occurs first).

Trailer

12 months excluding normal wear items.

*Refer to the express written, one-year limited warranty sheet for additional information.

NOTICE

Specifications sheet is subject to change and is not intended for use in installation design.



DA7000SSA3

Generator

MQ POWER DECIBEL LEVELS



Our soundproof housing allows substantially lower operating noise levels than competitive design. WhisperWatts™ are at home on construction sites, in residential neighborhoods, and at hospitals — just about anywhere.

- 90 — Subway / truck traffic
- 80 — Average city traffic
- 70 — Inside car at 60 mph
- 65 — **WhisperWatt™ at 23 feet**
- 60 — Air conditioner at 20 feet
- 50 — Normal conversation



GENERATOR OUTPUT PANEL

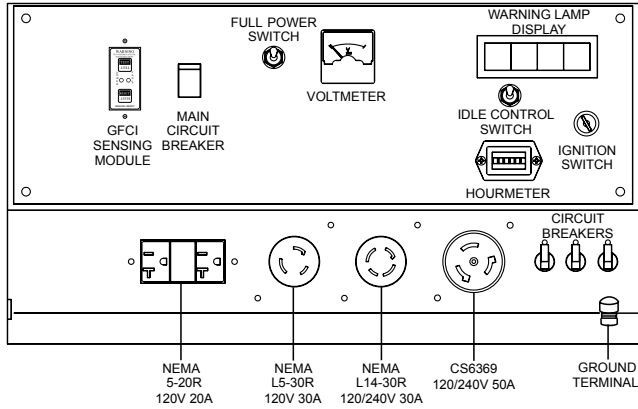

OPTIONAL GENERATOR FEATURES

- **Automatic Start/Stop Control** — Automatically starts and monitors generator during power failure when used in conjunction with a transfer switch.
- **Jacket Water Heater** — For easy starting in cold climates.
- **Solid State Battery Charger** — Provides fully automatic and self-adjusting charging to the generator's battery system.
- **Fuel/Water Separator** — Effectively separates damaging condensation from fuel.
- **Emergency Stop Switch** — When manually activated, shuts down generator in the event of an emergency.
- **Trailer Mounted Package** — Highway legal trailer with electric brakes with single axle configuration. Extra capacity fuel tank is also available.

OPTIONAL FUEL CELL FEATURES

- **Sub-base Cells (Single Wall or Double Wall)** — Additional fuel cell for extended run time. Available in a variety of configurations.



DA7000SSA3 Generator

SKID-MOUNT DIMENSIONS

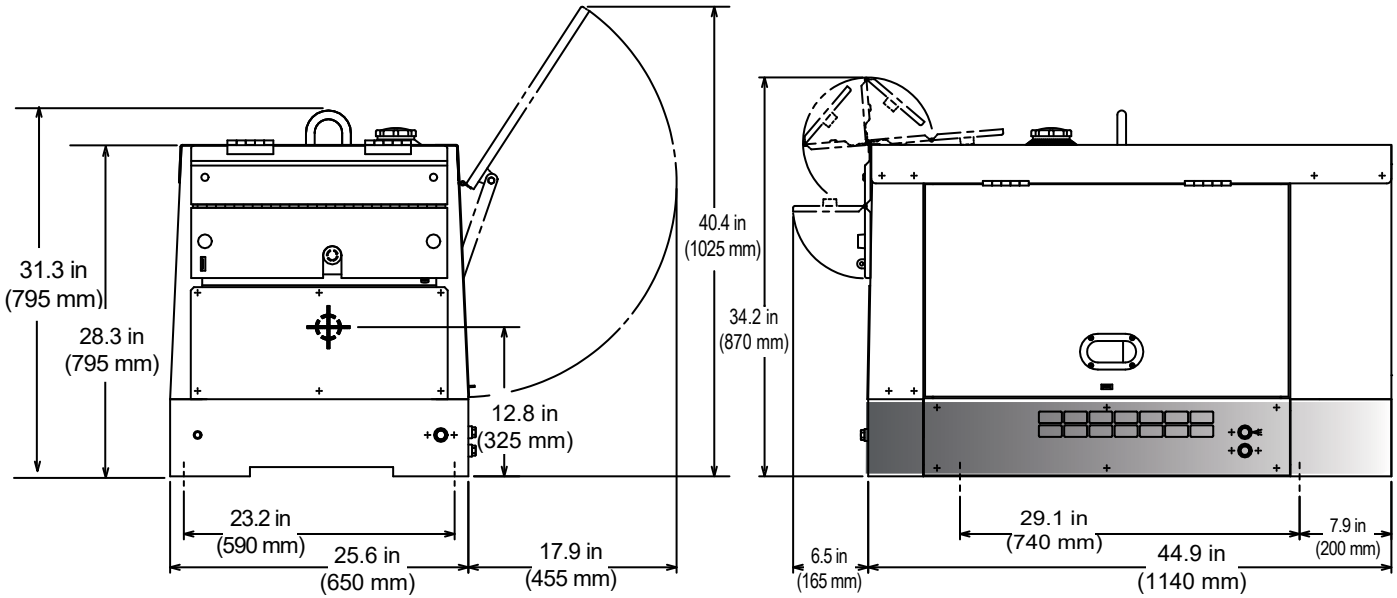

TRAILER-MOUNT DIMENSIONS

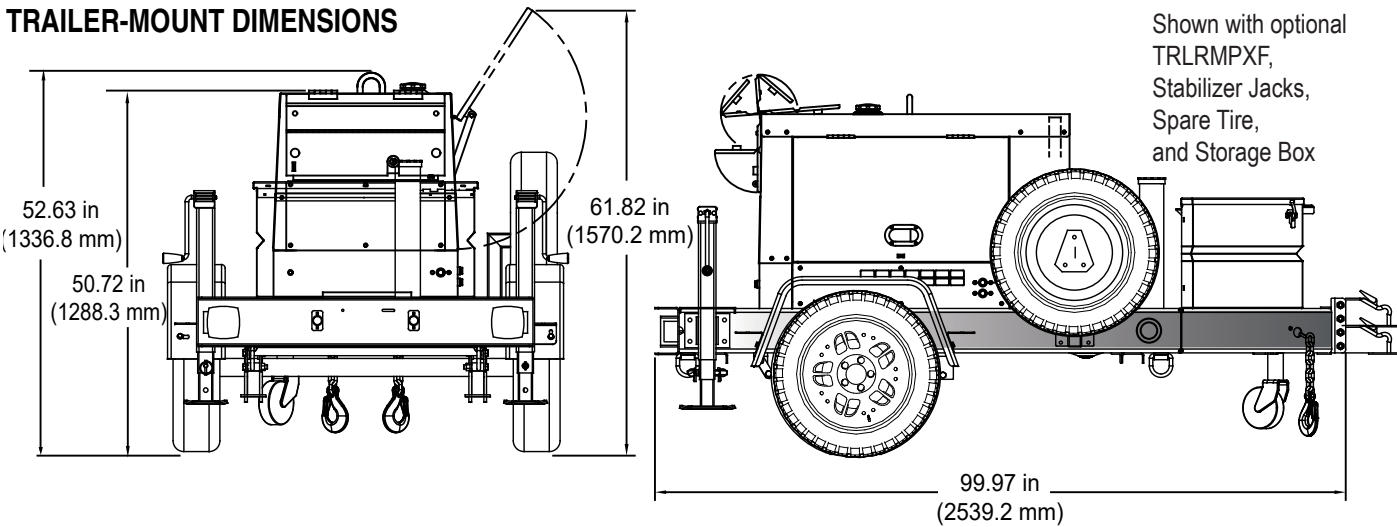

DA7000SSA3 Weights*

Dry Weight	533 lbs. (242 kg)
Wet Weight	597 lbs. (271 kg)
Max. Lifting Point Capacity	2,910 lbs. (1,320 kg)

* Weights do not include options.

DA7000SSA3 and TRLRMPXF Weights*

Dry Weight (with TRLRMPXF)	1,041 lbs. (472 kg)
Wet Weight (with TRLRMPXF)	1,105 lbs. (501 kg)

Generator can be placed on MQ Trailer Models TRLR10W, TRLRMP, TRLRMPXF, and TRLR75XF2.

NOTICE

Features and Specifications are subject to change without notice.



MULTIQUIP
6141 Katella Avenue Suite 200
Cypress, CA 90630
310-537-3700
E-MAIL: mq@multiquip.com
WEBSITE: www.multiquip.com