

# PARTS MANUAL



## **WHISPERWATT™ SERIES MODEL DCA15SPXU4F 60Hz GENERATOR (KUBOTA D1503-M DIESEL ENGINE)**

**PARTS LIST NO. M0871300204**

Revision #1 (02/10/17)

To find the latest revision of this  
publication, visit our website at:  
[www.mqpower.com](http://www.mqpower.com)



**THIS MANUAL MUST ACCOMPANY THE EQUIPMENT AT ALL TIMES.**

## **DCA15SPXU4F 60 Hz Generator**

Parts Ordering Procedures.....	3
Explanation Of Code In Remarks Column.....	4
Suggested Spare Parts .....	5

### **Component Drawings**

Generator Assembly.....	6-7
Control Box Assembly .....	8-11
Engine And Radiator Assembly .....	12-15
Output Terminal Assembly .....	16-17
Battery Assembly .....	18-19
Muffler Assembly .....	20-21
Fuel Tank Assembly .....	22-23
Enclosure Assembly .....	24-27
Rubber Seals Assembly .....	28-29
Battery Charger Assembly .....	30-31
Engine Block Heating Element Assembly .....	32-33
Nameplate And Decals Assembly .....	34-37

Terms And Conditions Of Sale — Parts .....	38
--	----

# PARTS ORDERING PROCEDURES

## Ordering parts has never been easier! Choose from three easy options:

Effective:  
January 1<sup>st</sup>, 2006

www.multiquip.com



### Order via Internet (Dealers Only):

Order parts on-line using Multiquip's SmartEquip website!

- View Parts Diagrams
- Order Parts
- Print Specification Information



If you have an MQ Account, to obtain a Username and Password, E-mail us at: [parts@multiquip.com](mailto:parts@multiquip.com).

To obtain an MQ Account, contact your District Sales Manager for more information.

Goto [www.multiquip.com](http://www.multiquip.com) and click on

**Order Parts** to log in and save!

Use the **internet** and qualify for a **5% Discount** on *Standard orders* for all orders which include complete part numbers.\*

Note: Discounts Are Subject To Change

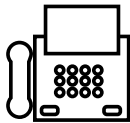

### Order via Fax (Dealers Only):

All customers are welcome to order parts via Fax.

**Domestic (US) Customers dial:**  
1-800-6-PARTS-7 (800-672-7877)

**Fax** your order in and qualify for a **2% Discount** on *Standard orders* for all orders which include complete part numbers.\*

Note: Discounts Are Subject To Change



**Order via Phone: Domestic (US) Dealers Call:**  
1-800-427-1244

### Non-Dealer Customers:

Contact your local Multiquip Dealer for parts or call 800-427-1244 for help in locating a dealer near you.



**International Customers** should contact their local Multiquip Representatives for Parts Ordering information.

## When ordering parts, please supply:

- |   |  |
|---|--|
| <input type="checkbox"/> Dealer Account Number                                | <input type="checkbox"/> Specify Preferred Method of Shipment:                         |
| <input type="checkbox"/> Dealer Name and Address                              | <input checked="" type="checkbox"/> UPS/Fed Ex <input checked="" type="checkbox"/> DHL |
| <input type="checkbox"/> Shipping Address (if different than billing address) | <input type="checkbox"/> Priority One <input checked="" type="checkbox"/> Truck        |
| <input type="checkbox"/> Return Fax Number                                    | <input type="checkbox"/> Ground  |
| <input type="checkbox"/> Applicable Model Number                              | <input type="checkbox"/> Next Day  |
| <input type="checkbox"/> Quantity, Part Number and Description of Each Part   | <input type="checkbox"/> Second/Third Day  |

### NOTICE

All orders are treated as *Standard Orders* and will ship the same day if received prior to 3PM PST.

WE ACCEPT ALL MAJOR CREDIT CARDS!



# EXPLANATION OF CODE IN REMARKS COLUMN

The following section explains the different symbols and remarks used in the Parts section of this manual. Use the help numbers found on the back page of the manual if there are any questions.

**NOTICE**

The contents and part numbers listed in the parts section are subject to change **without notice**. Multiquip does not guarantee the availability of the parts listed.

## SAMPLE PARTS LIST

NO.	PART NO.	PART NAME	QTY.	REMARKS
1	12345	BOLT .....	1	INCLUDES ITEMS W/%
2%		WASHER, 1/4 IN. ....		NOT SOLD SEPARATELY
2%	12347	WASHER, 3/8 IN. ...	1	MQ-45T ONLY
3	12348	HOSE .....	A/R	MAKE LOCALLY
4	12349	BEARING .....	1	S/N 2345B AND ABOVE

### NO. Column

**Unique Symbols** — All items with same unique symbol (@, #, +, %, or >) in the number column belong to the same assembly or kit, which is indicated by a note in the “Remarks” column.

**Duplicate Item Numbers** — Duplicate numbers indicate multiple part numbers, which are in effect for the same general item, such as different size saw blade guards in use or a part that has been updated on newer versions of the same machine.

**NOTICE**

When ordering a part that has more than one item number listed, check the remarks column for help in determining the proper part to order.

### PART NO. Column

**Numbers Used** — Part numbers can be indicated by a number, a blank entry, or TBD.

TBD (To Be Determined) is generally used to show a part that has not been assigned a formal part number at the time of publication.

A blank entry generally indicates that the item is not sold separately or is not sold by Multiquip. Other entries will be clarified in the “Remarks” Column.

### QTY. Column

**Numbers Used** — Item quantity can be indicated by a number, a blank entry, or A/R.

A/R (As Required) is generally used for hoses or other parts that are sold in bulk and cut to length.

A blank entry generally indicates that the item is not sold separately. Other entries will be clarified in the “Remarks” Column.

### REMARKS Column

Some of the most common notes found in the “Remarks” Column are listed below. Other additional notes needed to describe the item can also be shown.

**Assembly/Kit** — All items on the parts list with the same unique symbol will be included when this item is purchased.

Indicated by:

“INCLUDES ITEMS W/(unique symbol)”

**Serial Number Break** — Used to list an effective serial number range where a particular part is used.

Indicated by:

“S/N XXXXX AND BELOW”

“S/N XXXX AND ABOVE”

“S/N XXXX TO S/N XXX”

**Specific Model Number Use** — Indicates that the part is used only with the specific model number or model number variant listed. It can also be used to show a part is NOT used on a specific model or model number variant.

Indicated by:

“XXXXX ONLY”

“NOT USED ON XXXX”

**“Make/Obtain Locally”** — Indicates that the part can be purchased at any hardware shop or made out of available items. Examples include battery cables, shims, and certain washers and nuts.

**“Not Sold Separately”** — Indicates that an item cannot be purchased as a separate item and is either part of an assembly/kit that can be purchased, or is not available for sale through Multiquip.

## SUGGESTED SPARE PARTS

### DCA15SPXU4F WHISPERWATT GENERATOR WITH ISUZU 4LE2X DIESEL ENGINE

#### 1 TO 3 UNITS

Qty.	P/N	Description
3	0602046268	AIR FILTER, SAFETY
3	0602046335	ELEMENT, AIR, PRIMARY (INNER)
3	HH16432430	CARTRIDGE, OIL FILTER
5	1522143010	FUEL FILTER (MAIN)
5	A9924800024	CAP, FUEL TANK
5	0810105900	FUEL FILTER (TANK)
3	1G38297010	V-BELT
1	M0311500203	RADIATOR HOSE, UPPER
1	M0311500303	RADIATOR HOSE, LOWER
2	0601808803	CIRCUIT BREAKER, 1P, 20 AMP
2	0601870454	CIRCUIT BREAKER, 1P, 30 AMP
2	0601808808	CIRCUIT BREAKER, 2P, 30 AMP
2	0601808804	CIRCUIT BREAKER, 2P, 50 AMP
1	0601820663	AUTOMATIC VOLTAGE REGULATOR
4	0601810830	BULB, LAMPS
1	0601806642	FUSE, 5 AMP
3	0601806645	FUSE, 10 AMP
1	0601806640	FUSE, 65 AMP

#### NOTICE

Part number on this Suggested Spare Parts list may supersede/replace the P/N shown in the text pages of this book.

**GENERATOR ASSY.**

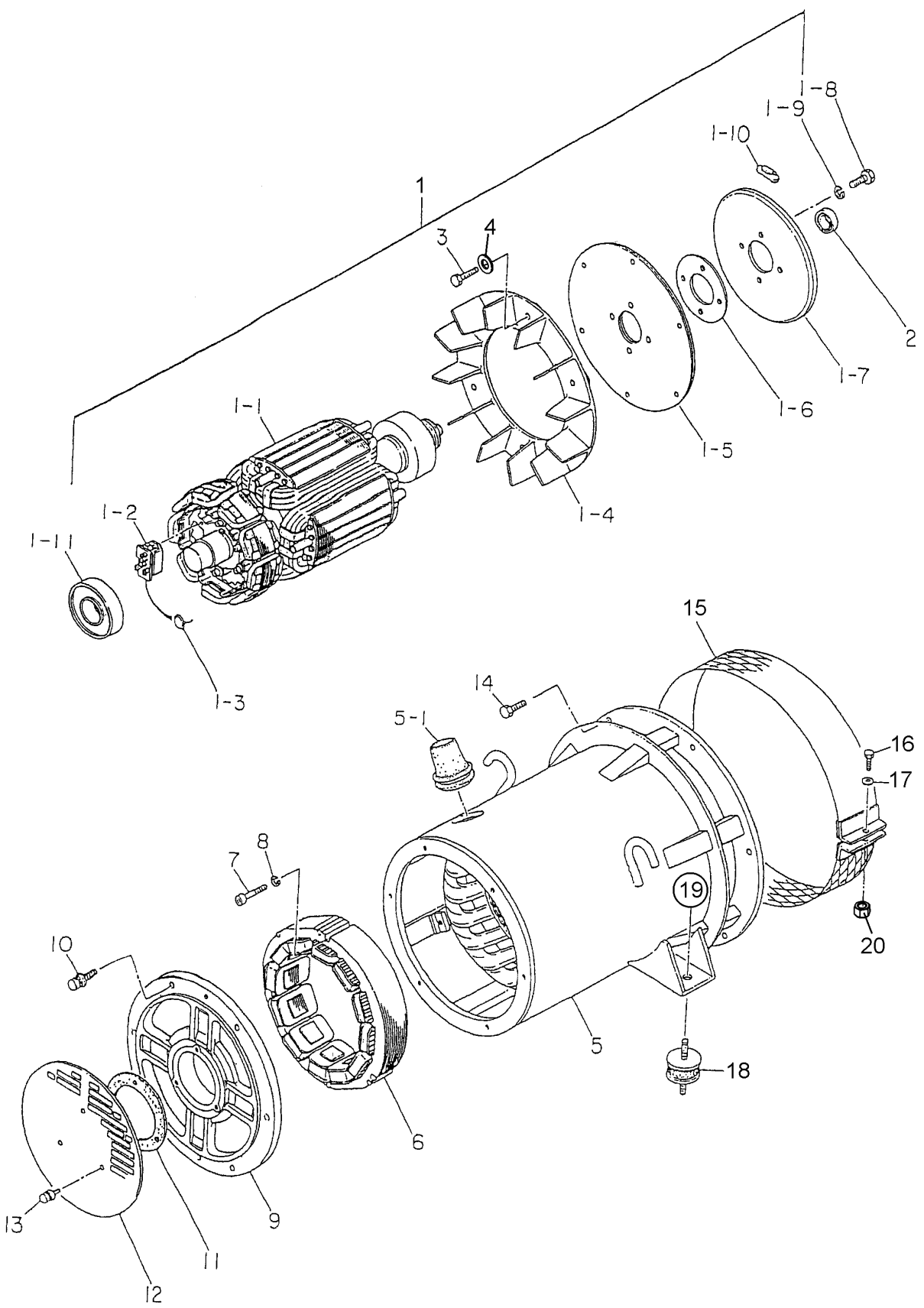

# GENERATOR ASSY.

<u>NO.</u>	<u>PART NO.</u>	<u>PART NAME</u>	<u>QTY.</u>	<u>REMARKS</u>
1	7671000102	ROTOR ASSY. ....	1.....	INCLUDES ITEMS W/%
1-1%		FIELD ASSY.	1	
1-2%	7961025004	RECTIFIER	1	
1-3%	0601822643	SURGE ABSORBER	1	
1-4%	8001070003	FAN	1	
1-5%	8351611004	COUPLING DISK	2	
1-6%	8351612004	WASHER, COUPLING HUB	1	
1-7%	8351615003	BALANCING PLATE .....	1.....	PURCHASE 1-10 AS A SET
1-8%	0010310025	HEX HEAD BOLT	4	
1-9%	0042610000	WASHER, LOCK	4	
1-10%	0601000209	BALANCING WEIGHT KIT	1	
1-11%	0071906308	BEARING, 6308DDU	1	
2%	0070506903	BEARING, 6903ZZ	1	
3%	0012808035	HEX HEAD BOLT	6	
4%	0042508000	WASHER, LOCK	6	
5	B0130101003	STATOR ASSY.	1	
5-1	0845041904	GROMMET	1	
6	8431350003	FIELD ASSY.,EXCITER	1	
7	0016008045	HEX SOCKET HEAD CAP SCREW	3	
8	0042508000	WASHER, LOCK	3	
9	8351315003	END BRACKET	1	
10	0017108035	HEX HEAD BOLT	6	
11	8351312004	PACKING	1	
12	B0155400504	COVER, SUCTION	1	
13	0017106016	HEX HEAD BOLT	3	
14	0012810030	HEX HEAD BOLT	6	
15	B0155400204	COVER, FAN	1	
16	03404 06040	HEX HEAD BOLT	1	
17	0041206000	WASHER, FLAT	1	
18	0605000409	RUBBER SUSPENSION	2	
19	0207010000	HEX NUT	2	
20	0601815000	NUT	1	

# CONTROL BOX ASSY.

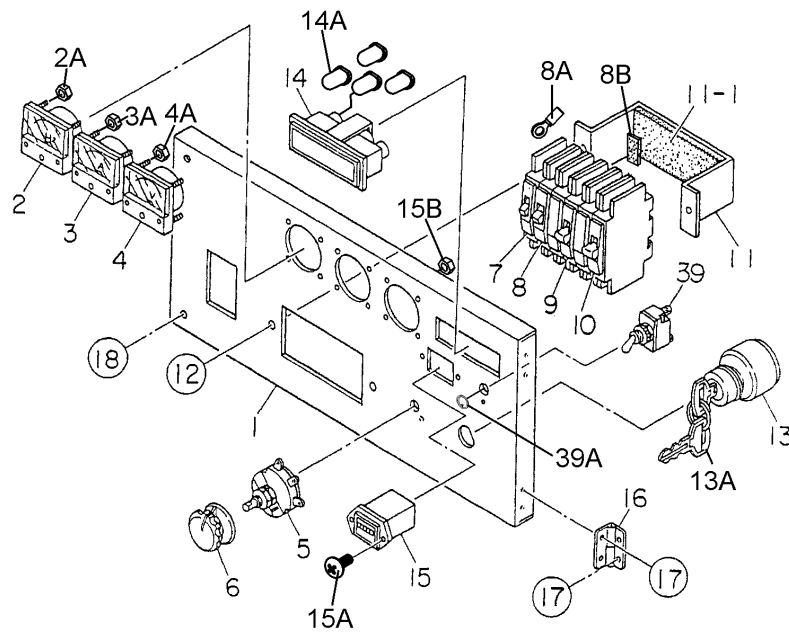
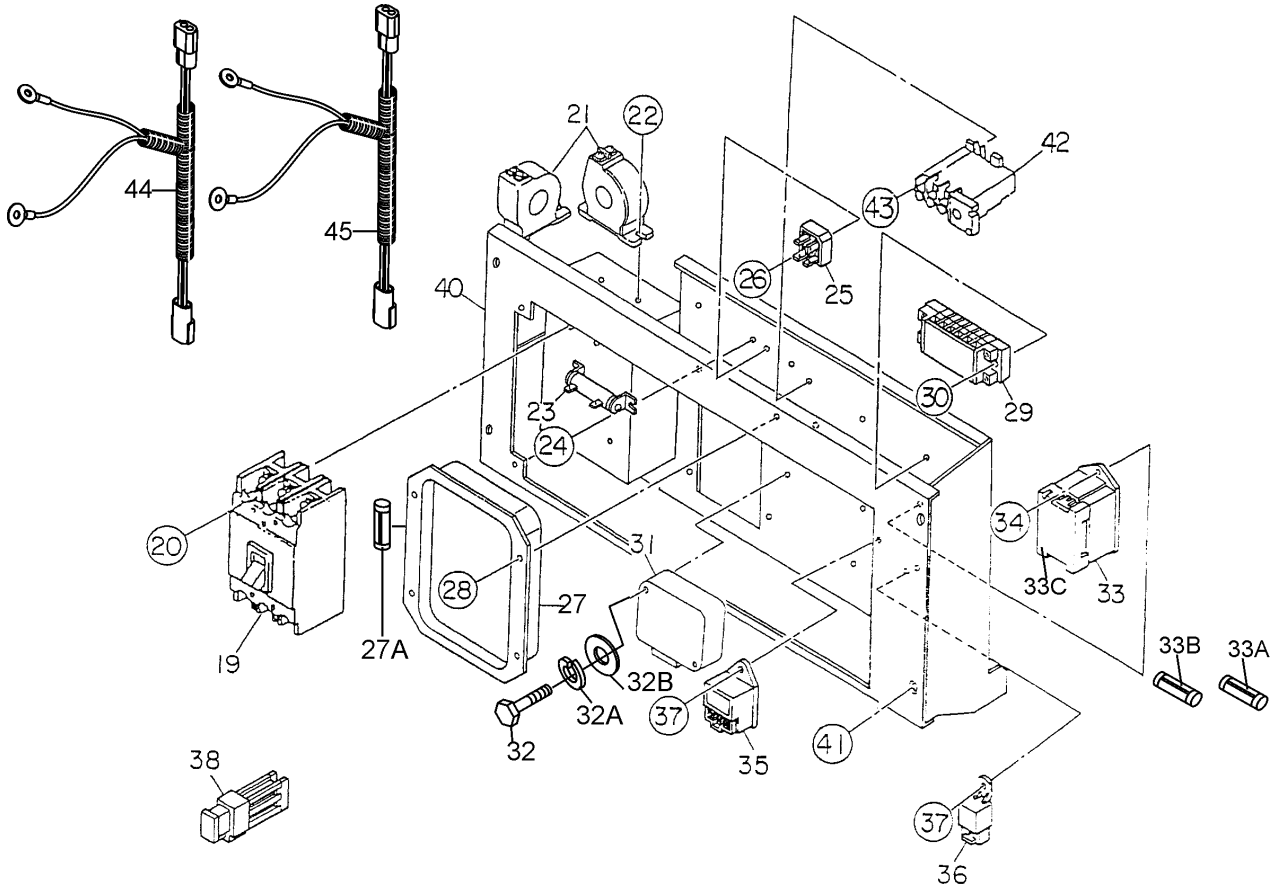



## CONTROL BOX ASSY.

<u>NO.</u>	<u>PART NO.</u>	<u>PART NAME</u>	<u>QTY.</u>	<u>REMARKS</u>
1	M0224000023	CONTROL PANEL	1	
2	0601800455	FREQUENCY METER, 45~65 Hz	1	
2A	0207003000	HEX NUT	4	
3	0601805746	AC AMMETER, 0~75/5A	1	
3A	0207003000	HEX NUT	4	
4	0601800281	AC VOLTMETER, 0~150/300V	1	
4A	0207003000	HEX NUT	4	
5	0601840073	RHEOSTAT (VR), 2W 1K OHM	1	
6	0601840121	KNOB, RHEOSTAT	1	
7	0601808803	CIRCUIT BREAKER, 1P 20A	1	
8	0601870454	CIRCUIT BREAKER, 1P 30A	1	
8A	0601815588	INSULATED FASTON TERMINAL	1	
8B	0222700050	RUBBER SEAL	1	
9	0601808808	CIRCUIT BREAKER, 2P 30A	1	
10	0601808804	CIRCUIT BREAKER, 2P 50A	1	
11	0261600004	BRACKET FITTING COVER	1	
11-1	0222100120	RUBBER CUSHION	1	
12	0021806015	MACHINE SCREW	2	
13	1628663602	STARTER SWITCH .....	1	REPLACES P/N 0602100077
13A	3741055150	KEY, STARTER SWITCH	1	
14	0601810523	WARNING LAMP UNIT	1	
14A	0601810830	BULB	4	
15	0601800682	HOUR METER	1	
15A	0027403010	MACHINE SCREW	2	
15B	0207003000	HEX NUT	2	
16	0605010060	HINGE	2	
17	0027103008	MACHINE SCREW	8	
18	0021806030	MACHINE SCREW	2	
19	0601808831	CIRCUIT BREAKER, 70A	1	
20	0021004070	MACHINE SCREW	4	
21	0601801122	CURRENT TRANS., AMMETER, 150/5A	1	
22	0027105015	MACHINE SCREW	2	
23	0601842384	RESISTOR, GG20W 50 OHM	1	
24	0027104015	MACHINE SCREW	2	
25	0601820038	RECTIFIER	1	
26	0027104020	MACHINE SCREW	1	
27	0601820663	AUTOMATIC VOLTAGE REGULATOR	1	
27A	0601806682	FUSE, 5A	1	
28	0027105015	MACHINE SCREW	4	
29	0601815759	TERMINAL BOARD	1	
30	0027104020	MACHINE SCREW	2	
31	1G38560601	ENGINE CONTROL UNIT .....	1	REPLACES P/N 0602202634
32	0021005050	MACHINE SCREW	2	
32A	0040005000	WASHER, LOCK	2	
32B	0041205000	WASHER, FLAT	2	

# CONTROL BOX ASSY.

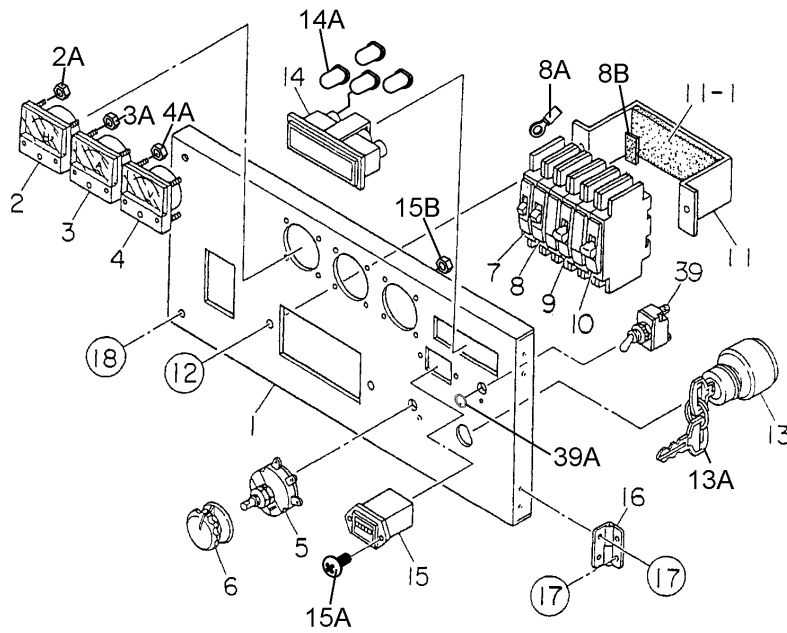
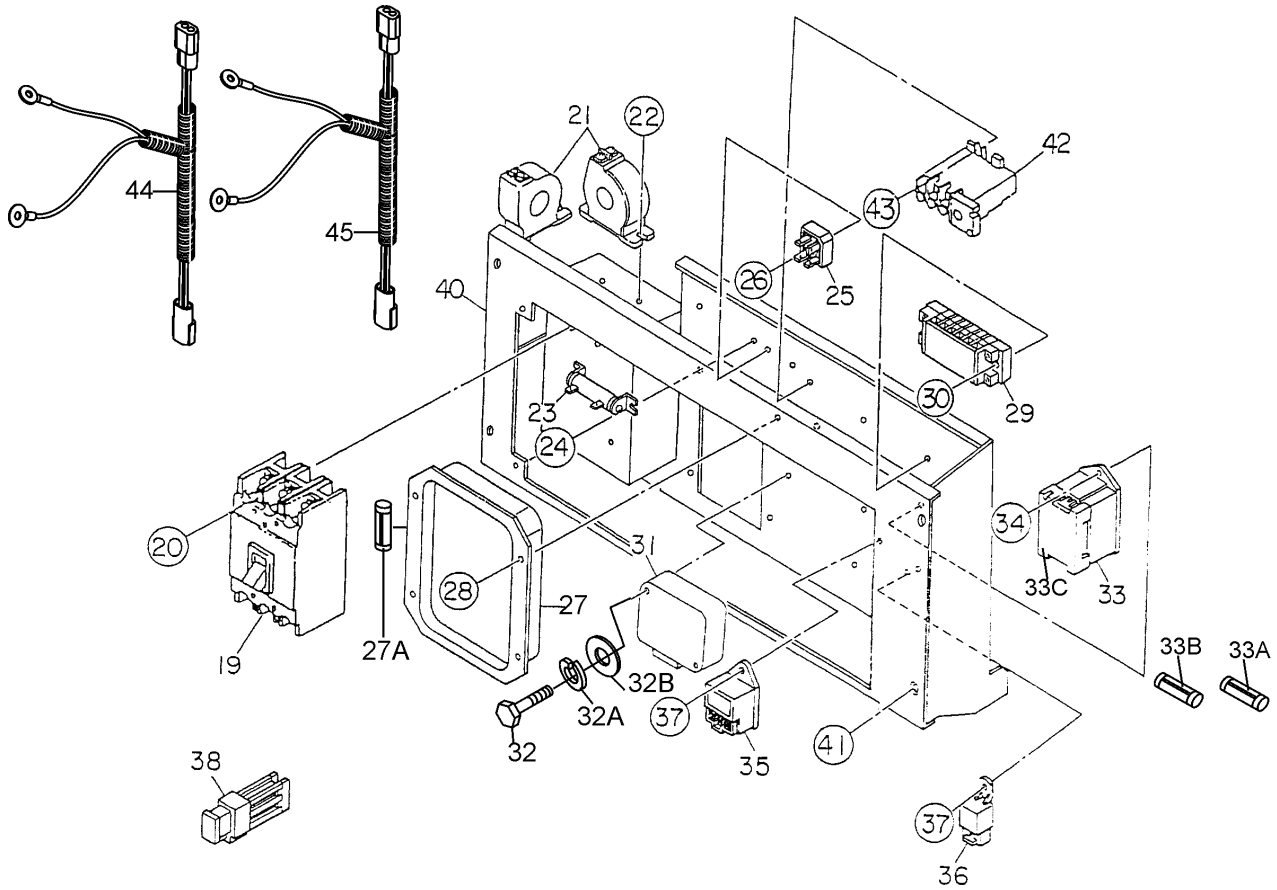

## CONTROL BOX ASSY.

<u>NO.</u>	<u>PART NO.</u>	<u>PART NAME</u>	<u>QTY.</u>	<u>REMARKS</u>
33	0261200004	FUSE BOX	1	
33A	0601806642	FUSE, 5A	5	
33B	0601806645	FUSE, 10A	4	
33C	M9521000204	DECAL: FUSE BOX	1	
34	0027105015	MACHINE SCREW	2	
35	RP42153730	RELAY ASSY.....	1	REPLACES P/N RP42153731
36	6888153542	RELAY .....	1	REPLACES P/N 0602202566
37	0027104020	MACHINE SCREW	2	
38	0601806640	FUSE, 65A	1	
39	0601830708	SPEED CONTROL SWITCH	1	
39A	0601831978	INSTALLATION RING	1	
40	M0214000102	CONTROL BOX	1	
41	0016908020	HEX HEAD BOLT	4	
42	0601820891	OVER CURRENT RELAY	1	
43	0027104015	MACHINE SCREW	2	
44	M0247700010	GENERATOR WIRE HARNESS	1	
45	M0358200100	ENGINE WIRE HARNESS	1	

# ENGINE AND RADIATOR ASSY.

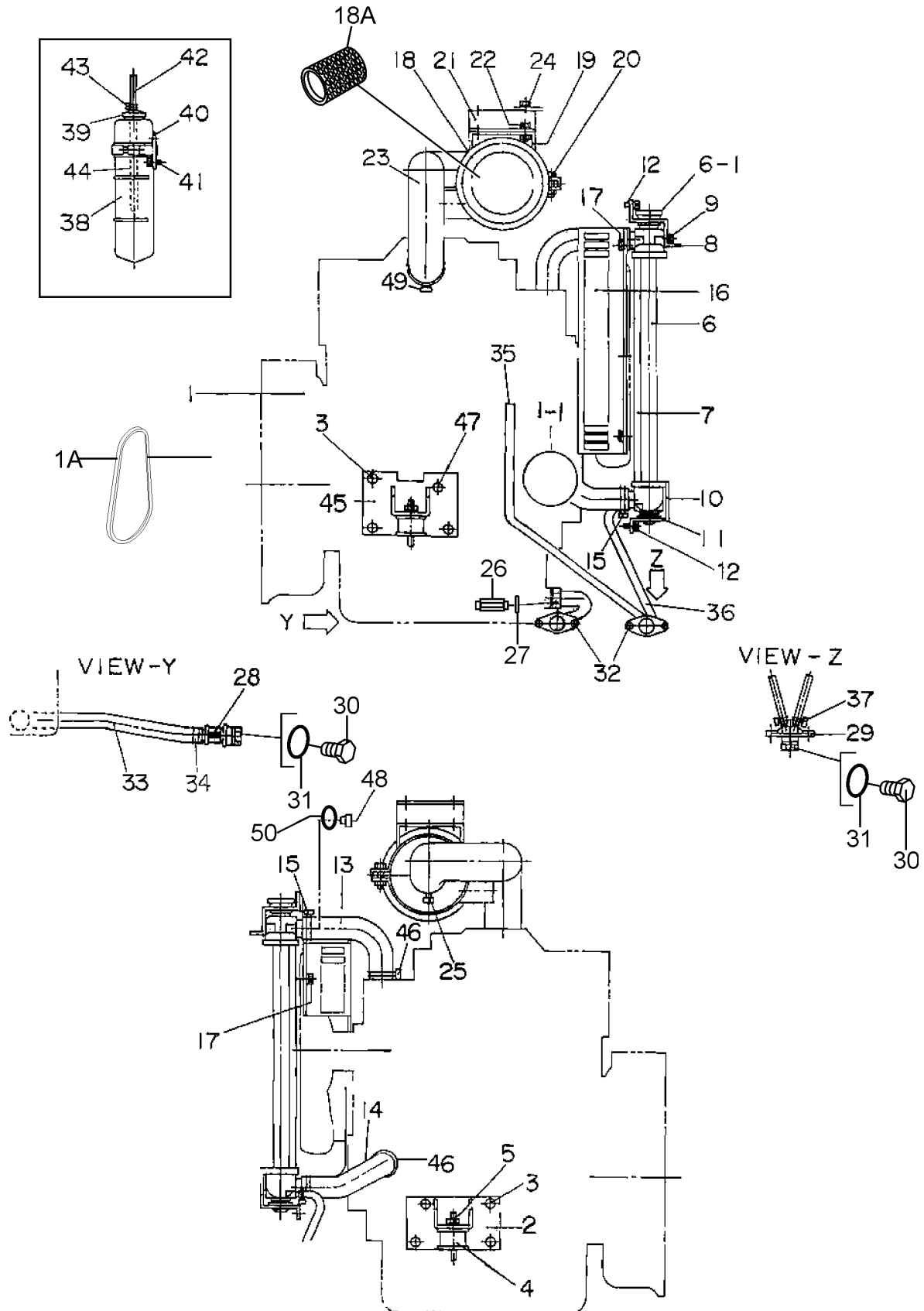

## ENGINE AND RADIATOR ASSY.

<u>NO.</u>	<u>PART NO.</u>	<u>PART NAME</u>	<u>QTY.</u>	<u>REMARKS</u>
1	M0924200014	ENGINE, KUBOTA D1503-M	1	
1A	1G38297010	FAN BELT .....	1	REPLACES P/N 1G38297011
1-1	HH16432430	CARTRIDGE, OIL FILTER .....	1	REPLACES P/N 1641432433
2	M0304200104	ENGINE FOOT	1	
3	012212025	HEX. HEAD BOLT .....	7	REPLACES P/N 0012412025
4	Y0605000409	RUBBER SUSPENSION	2	
5	021112140	HEX. NUT .....	2	REPLACES P/N 0207010000
6	0602012733	RADIATOR	1	
6-1	0602011079	CAP, RADIATOR	1	
7	0220300400	RUBBER SEAL	2	
8	M0311200004	BRACKET, RADIATOR	1	
9	011208030	HEX. HEAD BOLT .....	2	REPLACES P/N 0016908030
10	M0311200203	BRACKET, RADIATOR	1	
11	M9312200104	MOUNT RUBBER	2	
12	011008020	HEX. HEAD BOLT .....	5	REPLACES P/N 0016908020
13	M0311500203	RADIATOR HOSE, UPPER	1	
14	M0311500303	RADIATOR HOSE, LOWER	1	
15	0605515149	HOSE BAND	2	
16	M0311300103	FAN GUARD	1	
17	011008020	HEX. HEAD BOLT .....	3	REPLACES P/N 0016908020
18	0602046268	AIR FILTER	1	
18A	0602046335	ELEMENT, AIR FILTER .....	1	REPLACES P/N 113043002
19	M0375200103	BAND, AIR CLEANER	1	
20	011208030	HEX. HEAD BOLT .....	1	REPLACES P/N 0016908030
21	M0374200004	BRACKET, AIR CLEANER	1	
22	011008020	HEX. HEAD BOLT .....	2	REPLACES P/N 0016908020
23	M0374100103	HOSE, AIR CLEANER	1	
24	0019208020	HEX. HEAD BOLT	2	
25	0605515147	HOSE BAND	1	
26	M0322200004	DRAIN JOINT	1	
27	0602021193	PACKING	1	
28	1502025103C	DRAIN JOINT .....	1	REPLACES P/N M9200000003
29	1622014103	DRAIN JOINT .....	1	REPLACES P/N M9602000003
30	0802011104	PLUG .....	2	REPLACES P/N M9200200004
31	0150000018	O-RING	2	
32	011206020	HEX. HEAD BOLT .....	4	REPLACES P/N 0019206020
33	0269200500	PUSH LOCK HOSE	1	
34	0605515073	HOSE BAND	2	
35	0199900500	DRAIN HOSE	1	
36	0199900350	DRAIN HOSE	1	
37	0605515170	HOSE BAND .....	4	REPLACES P/N 0605515106
38	0802081403D	RESERVE TANK .....	1	REPLACES P/N M9300000003

# ENGINE AND RADIATOR ASSY. (CONTINUED)

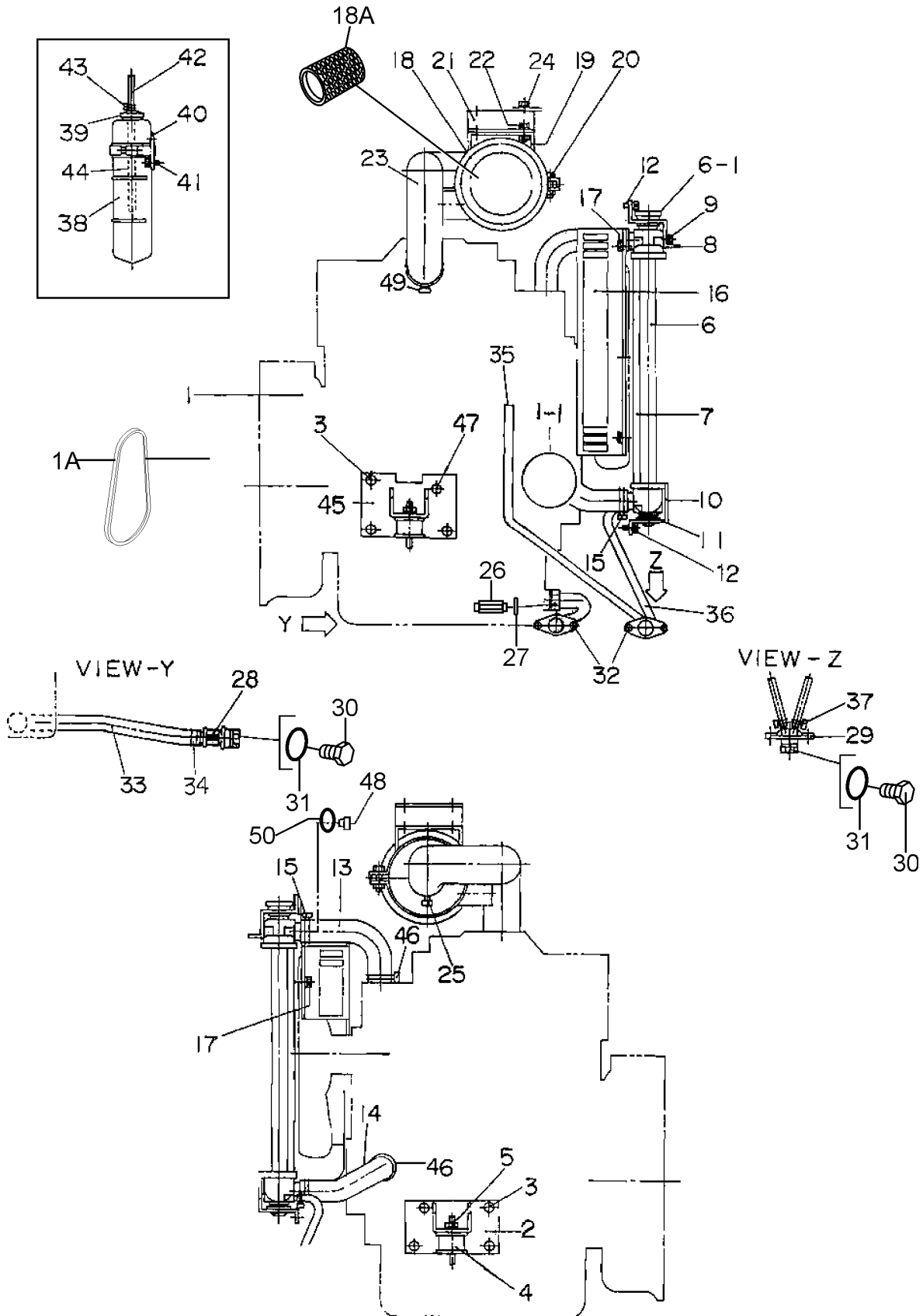

## **ENGINE AND RADIATOR ASSY. (CONTINUED)**

---

<b><u>NO.</u></b>	<b><u>PART NO.</u></b>	<b><u>PART NAME</u></b>	<b><u>QTY.</u></b>	<b><u>REMARKS</u></b>
39	0802081104	CAP, RESERVE TANK .....	1.....	REPLACES P/N M9300100003
40	M1318100204	BRACKET, RESERVE TANK	1	
41	011106015	HEX. HEAD BOLT .....	3.....	REPLACES P/N 0017106015
42	0199900450	HOSE	1	
43	0605515170	HOSE BAND.....	2.....	REPLACES P/N 0605515106
44	0199100215	HOSE	1	
45	M0304200004	ENGINE FOOT	1	
46	0605515149	HOSE BAND	2	
47	0012410025	HEX. HEAD BOLT	1	
48	M9200100904	PLUG	1	
49	0605515199	HOSE BAND	1	
50	0150000016	O-RING	1	

# OUTPUT TERMINAL ASSY.

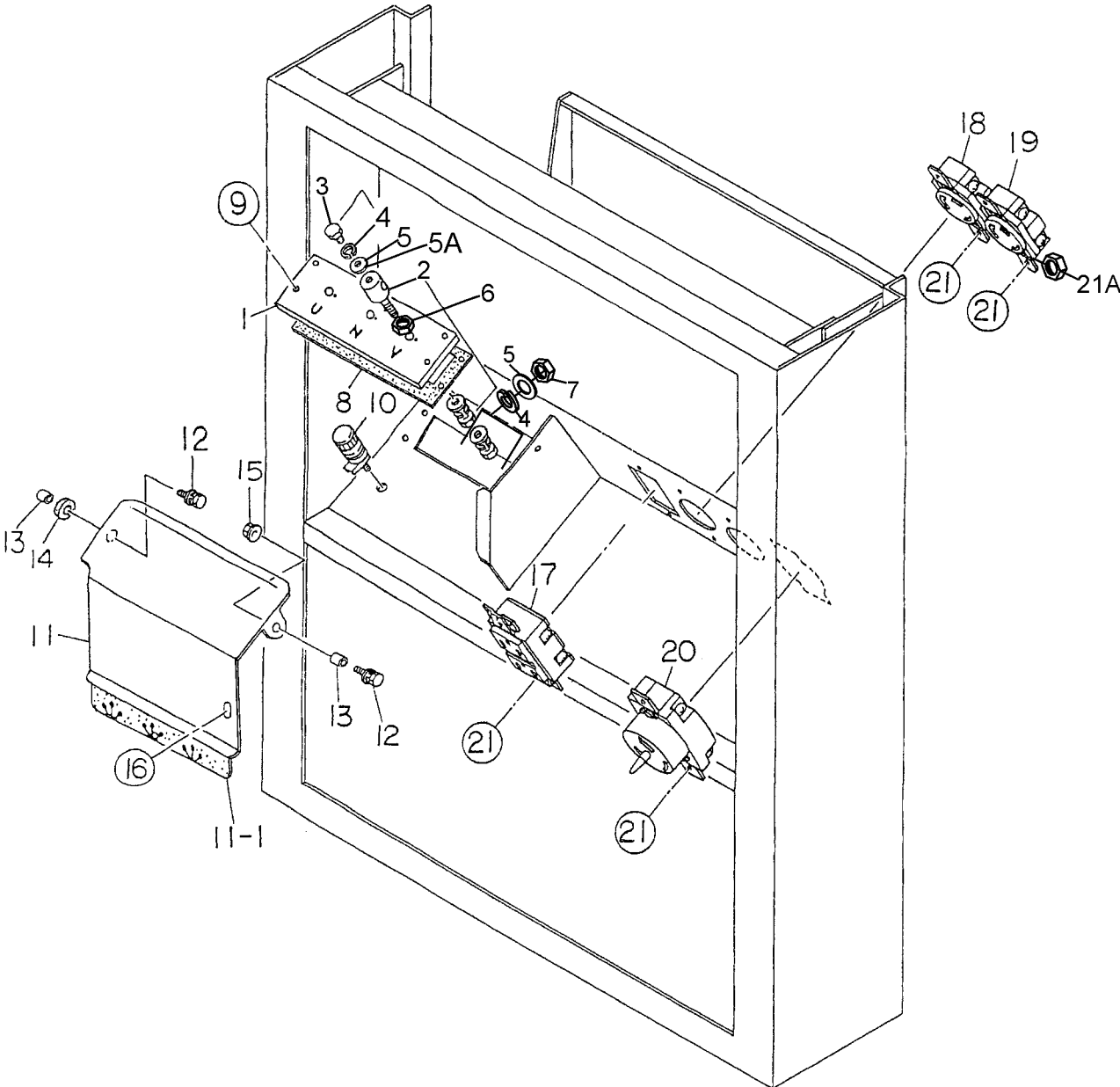

ADD THE FOLLOWING DIGITS AFTER THE PART NUMBER WHEN ORDERING ANY PAINTED PANEL TO INDICATE COLOR OF UNIT:

1-ORANGE	6-CATERPILLAR YELLOW
2-WHITE	7-CATO GOLD
3-SPECTRUM GREY	8-RED
4-SUNBELT GREEN	9-DESERT TAN
5-BLACK	

THE SERIAL NUMBER MAY BE REQUIRED.



## OUTPUT TERMINAL ASSY.

<u>NO.</u>	<u>PART NO.</u>	<u>PART NAME</u>	<u>QTY.</u>	<u>REMARKS</u>
1	M0232700014	SET BOARD, OUTPUT TERMINAL	1	
2	M0235100014	OUTPUT TERMINAL BOLT	3	
3	0801832204	HEX HEAD BOLT .....	3.....	REPLACES P/N M9220000104
4	0040008000	WASHER, LOCK	9	
5	0041208000	WASHER, FLAT	3	
5A	0041408000	WASHER, FLAT	6	
6	0039508000	HEX NUT	3	
7	0039508000	HEX NUT	3	
8	0235500004	RUBBER SEAL	1	
9	0016906020	HEX HEAD BOLT	4	
10	0601815109	GROUND TERMINAL	1	
11	M0238100003	COVER, OUTPUT TERMINAL	1	
11-1	M0235400004	RUBBER SHEET	1	
12	0016906020	HEX HEAD BOLT	2	
13	M9118000104	COLLAR	2	
14	M9312200004	STAY RUBBER	1	
15	0207006000	HEX NUT	1	
16	0016906015	HEX HEAD BOLT	1	
17	0601814013	RECEPTACLE, 5-20R	1	
18	0601811035	RECEPTACLE, L5-30R	1	
19	0601811033	RECEPTACLE, L6-30R	1	
20	0601814014	RECEPTACLE, CS-6369	1	
21	0027104015	MACHINE SCREW	8	
21A	0207004000	HEX NUT	8	

**BATTERY ASSY.**

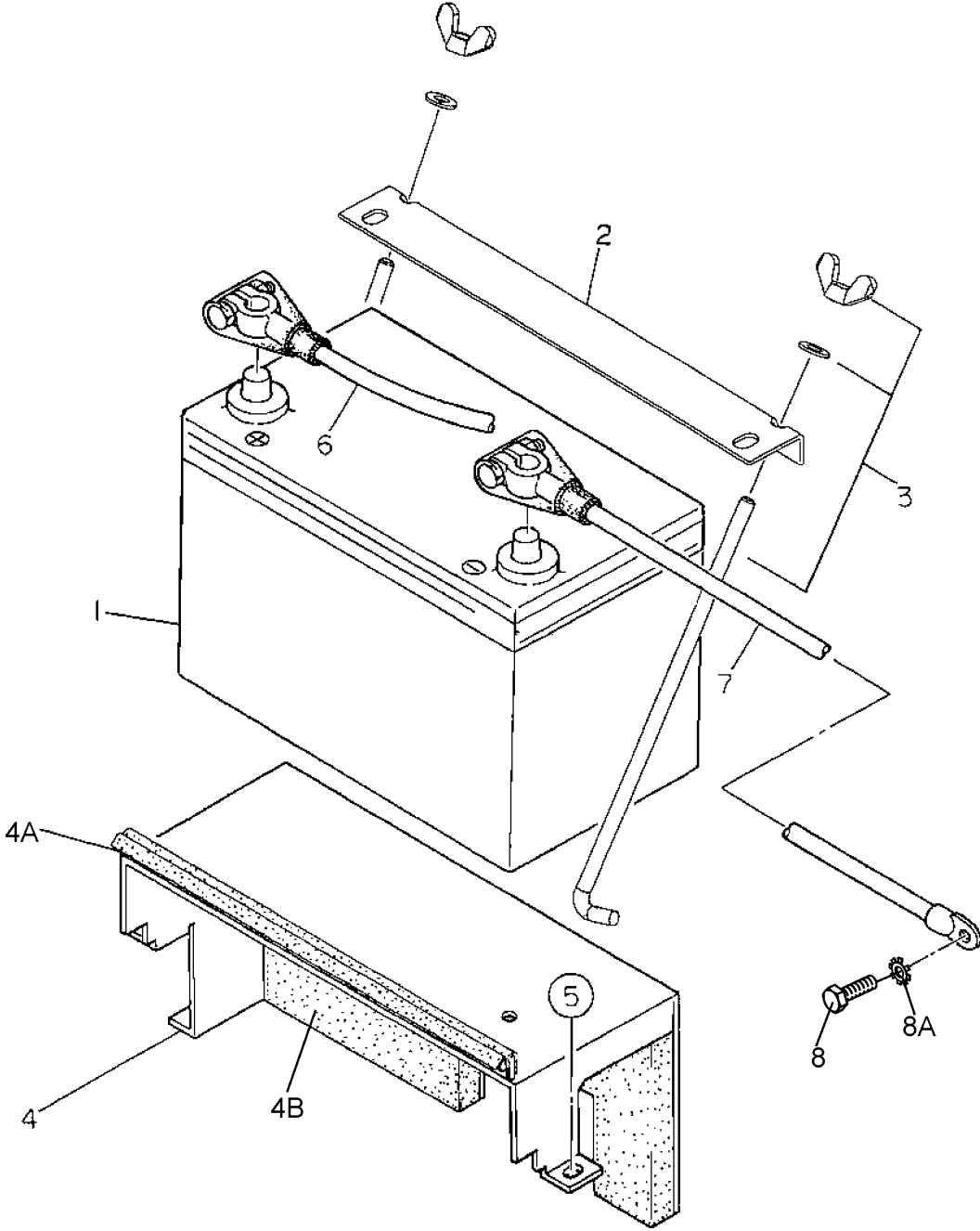

## BATTERY ASSY.

---

<u>NO.</u>	<u>PART NO.</u>	<u>PART NAME</u>	<u>QTY.</u>	<u>REMARKS</u>
1	0602220193	BATTERY .....	1.....	80D26R
2	M0484600004	BATTERY BAND	1	
3	0602220920	BATTERY BOLT	2	
4	M0344000103	BATTERY BASE	2	
4A	0314200380	RUBBER SEAL	1	
4B	0494000304	ACOUSTIC SHEET	1	
5	0016908020	HEX HEAD BOLT	3	
6	M0348200004	BATTERY CABLE	1	
7	M0348200104	BATTERY CABLE	1	
8	0012412025	HEX HEAD BOLT	1	
8A	0040512000	TOOTHED WASHER	1	

# MUFFLER ASSY.

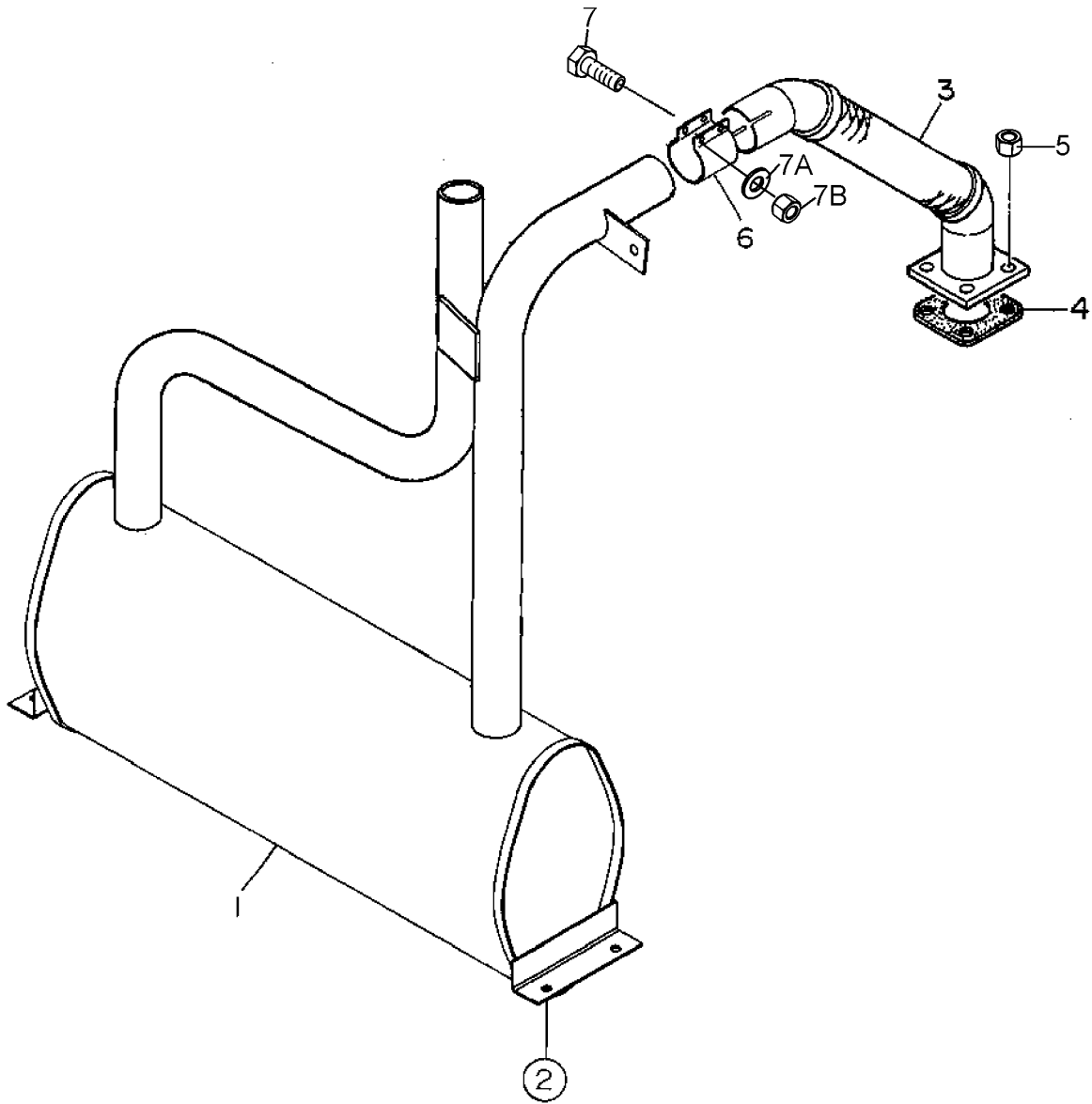

## MUFFLER ASSY.

---

<u>NO.</u>	<u>PART NO.</u>	<u>PART NAME</u>	<u>QTY.</u>	<u>REMARKS</u>
1	M0331000003	MUFFLER	1	
2	0016908020	HEX HEAD BOLT	5	
3	M0334000103	EXHAUST PIPE	1	
4	1526312370	GASKET .....	1.....	REPLACES P/N 1526312371
5	0207108000	HEX NUT	4	
6	06023 25094	PIPE BAND	4	
7	0341510040	HEX HEAD BOLT	2	
7A	0042410000	WASHER, FLAT	2	
7B	0207110000	HEX NUT	2	

# FUEL TANK ASSY.

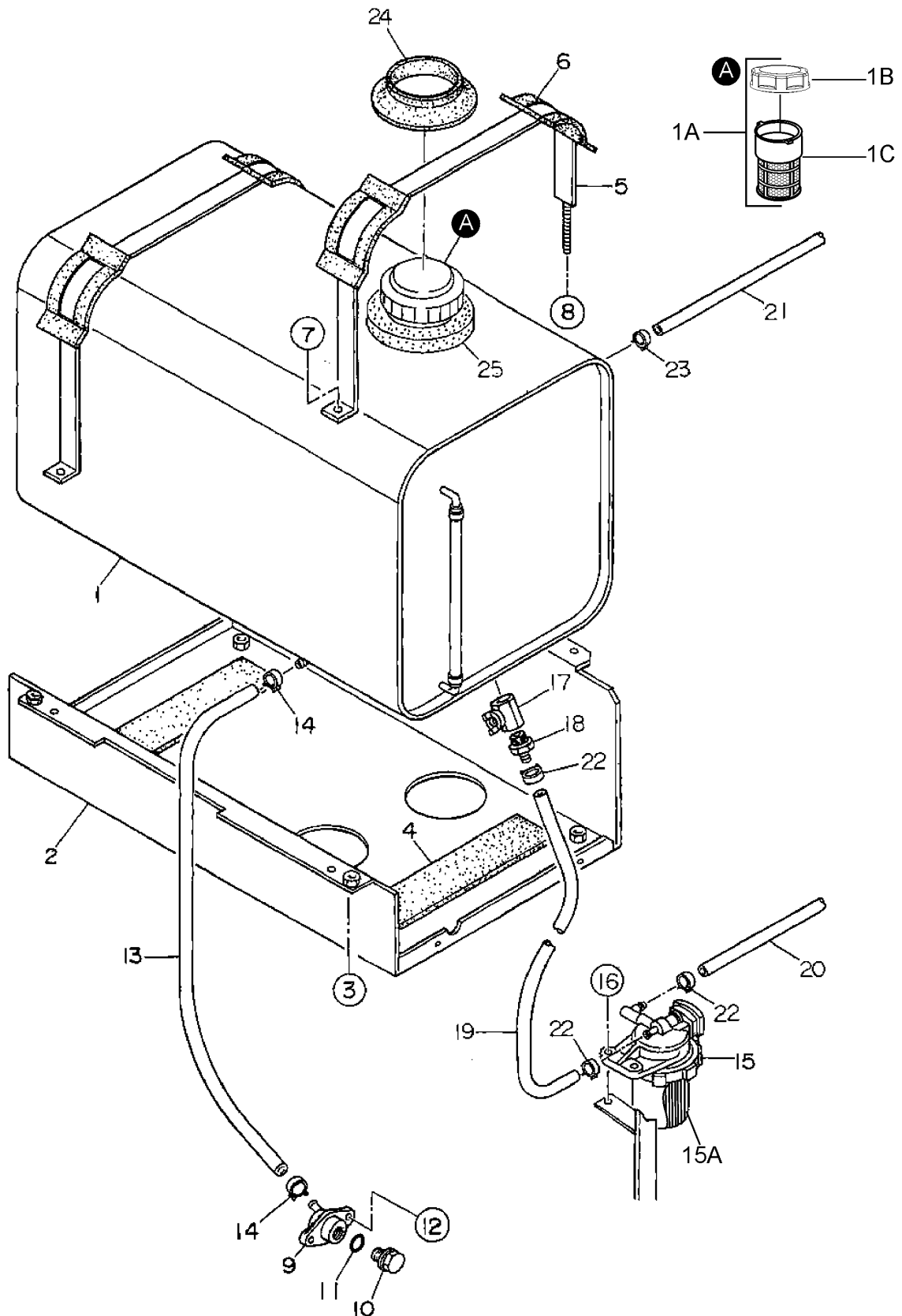

## FUEL TANK ASSY.

<u>NO.</u>	<u>PART NO.</u>	<u>PART NAME</u>	<u>QTY.</u>	<u>REMARKS</u>
1	M0364000003	FUEL TANK	1	
1A	A9924800024	CAP, FUEL TANK ASSY.	1	
1B	A9924800024	CAP, FUEL TANK .....	1.....	REPLACES P/N 0810105800
1C	0810105900	FUEL FILTER	1	
2	M0364300103	FUEL TANK BASE	1	
3	011008020	HEX. HEAD BOLT .....	4.....	REPLACES P/N 0016908020
4	0222100300	TANK SHEET	2	
5	M0365200004	TANK BAND	2	
6	M9310500104	PAD, TANK BAND	4	
7	011008020	HEX. HEAD BOLT .....	2.....	REPLACES P/N 0016908020
8	0207308000	HEX. NUT	2	
9	7812014003B	DRAIN JOINT .....	1.....	REPLACES P/N M2320300103
10	0802011104	PLUG .....	1.....	REPLACES P/N M9200200004
11	0150000018	O-RING	1	
12	011206020	HEX. HEAD BOLT .....	2.....	REPLACES P/N 0019206020
13	0199901200	DRAIN HOSE	1	
14	0605515198	HOSE BAND	2	
15	1522143010	FUEL FILTER.....	1.....	REPLACES P/N 0602042462
15A	1522143170	ELEMENT, FUEL FILTER .....	1.....	REPLACES P/N 1522143172
16	011208030	HEX. HEAD BOLT .....	2.....	REPLACES P/N 0016908030
17	0603325013	VALVE	1	
18	0602022219	HOSE JOINT	1	
19	0199900200	SUCTION HOSE	1	
20	Y0199900250	SUCTION HOSE	1	
21	0199700250	RETURN HOSE	1	
22	0605515198	HOSE BAND	4	
23	Y0605515104	HOSE BAND	2	
24	M0365400004	RUBBER SEAL	1	
25	M0364400004	RUBBER SEAL	1	

# ENCLOSURE ASSY.

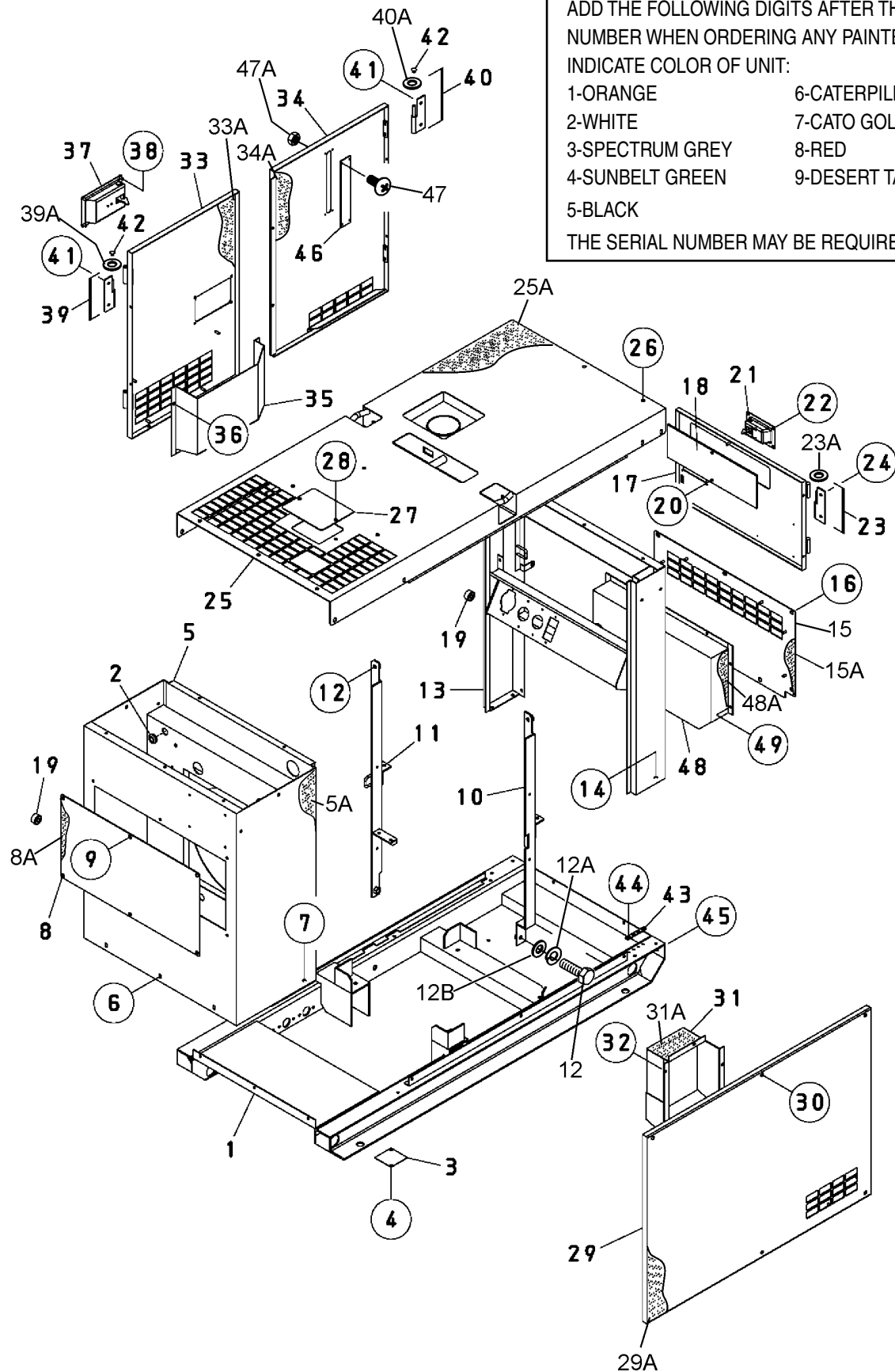

ADD THE FOLLOWING DIGITS AFTER THE PART NUMBER WHEN ORDERING ANY PAINTED PANEL TO INDICATE COLOR OF UNIT:

- |                 |                      |
|-----------------|----------------------|
| 1-ORANGE        | 6-CATERPILLAR YELLOW |
| 2-WHITE         | 7-CATO GOLD          |
| 3-SPECTRUM GREY | 8-RED                |
| 4-SUNBELT GREEN | 9-DESERT TAN         |

5-BLACK  
THE SERIAL NUMBER MAY BE REQUIRED.



## ENCLOSURE ASSY.

<u>NO.</u>	<u>PART NO.</u>	<u>PART NAME</u>	<u>QTY.</u>	<u>REMARKS</u>
1	M0414000202	BASE	1	
2	0601850239	GROMMET	1	
3	M0414800004	COVER	1	
4	0016906015	HEX. HEAD BOLT	2	
5	M0424000112	FRONT FRAME	1	
5A	M0494100514	ACOUSTIC SHEET	1	
6	0019208020	HEX. HEAD BOLT	3	
7	011008020	HEX. HEAD BOLT .....	2.....	REPLACES P/N 0016908020
8	M0485400004	COVER, FRONT FRAME	1	
8A	M0495100104	ACOUSTIC SHEET	1	
9	0019208020	HEX. HEAD BOLT	6	
10	M0434300203	HANGER	1	
11	M0434300303	HANGER	1	
12	0012312030	HEX. HEAD BOLT .....	4.....	REPLACES P/N 0013612030
12A	0040012000	WASHER, LOCK	4	
12B	031112230	WASHER, FLAT .....	4.....	REPLACES P/N 0041212000
13	M0444000202	REAR FRAME	1	
14	011008020	HEX. HEAD BOLT .....	5.....	REPLACES P/N 0016908020
15	M0444300203	COVER, REAR FRAME	1	
15A	M0444100104	ACOUSTIC SHEET	1	
16	0019208020	HEX. HEAD BOLT	7	
17	M0444200003	DOOR, REAR FRAME	1	
18	M0444600004	WINDOW PLATE	1	
19	0601851613	STOPPER	2	
20	0176060030	NUT, FLANGE 6MM.....	2.....	REPLACES P/N 0207006000
21	0605010230	DOOR HANDLE	1	
22	0021805015	MACHINE SCREW	4	
23	M9112100004	HINGE	2	
23A	M9118000004	WASHER	2	
24	0019206015	HEX. HEAD BOLT	4	
25	M0464000202	ROOF PANEL	1	
25A	M0494500604	ACOUSTIC SHEET	1	
26	0019208020	HEX. HEAD BOLT	16	
27	M1465400104	COVER	1	
28	0019208020	HEX. HEAD BOLT	2	
29	M0454100203	SIDE PANEL	1	
29A	M0494402404	ACOUSTIC SHEET	1	
30	Y0019208035	HEX. HEAD BOLT	6	
31	M0454300404	DUCT	1	
31A	M0414000203	ACOUSTIC SHEET	1	
32	0176060030	HEX. NUT .....	6.....	REPLACES P/N 0601850240
33	M0414800005	SIDE DOOR	1	
33A	0016906016	ACOUSTIC SHEET	1	

# ENCLOSURE ASSY. (CONTINUED)

ADD THE FOLLOWING DIGITS AFTER THE PART NUMBER WHEN ORDERING ANY PAINTED PANEL TO INDICATE COLOR OF UNIT:

- |                 |                      |
|-----------------|----------------------|
| 1-ORANGE        | 6-CATERPILLAR YELLOW |
| 2-WHITE         | 7-CATO GOLD          |
| 3-SPECTRUM GREY | 8-RED                |
| 4-SUNBELT GREEN | 9-DESERT TAN         |

THE SERIAL NUMBER MAY BE REQUIRED.

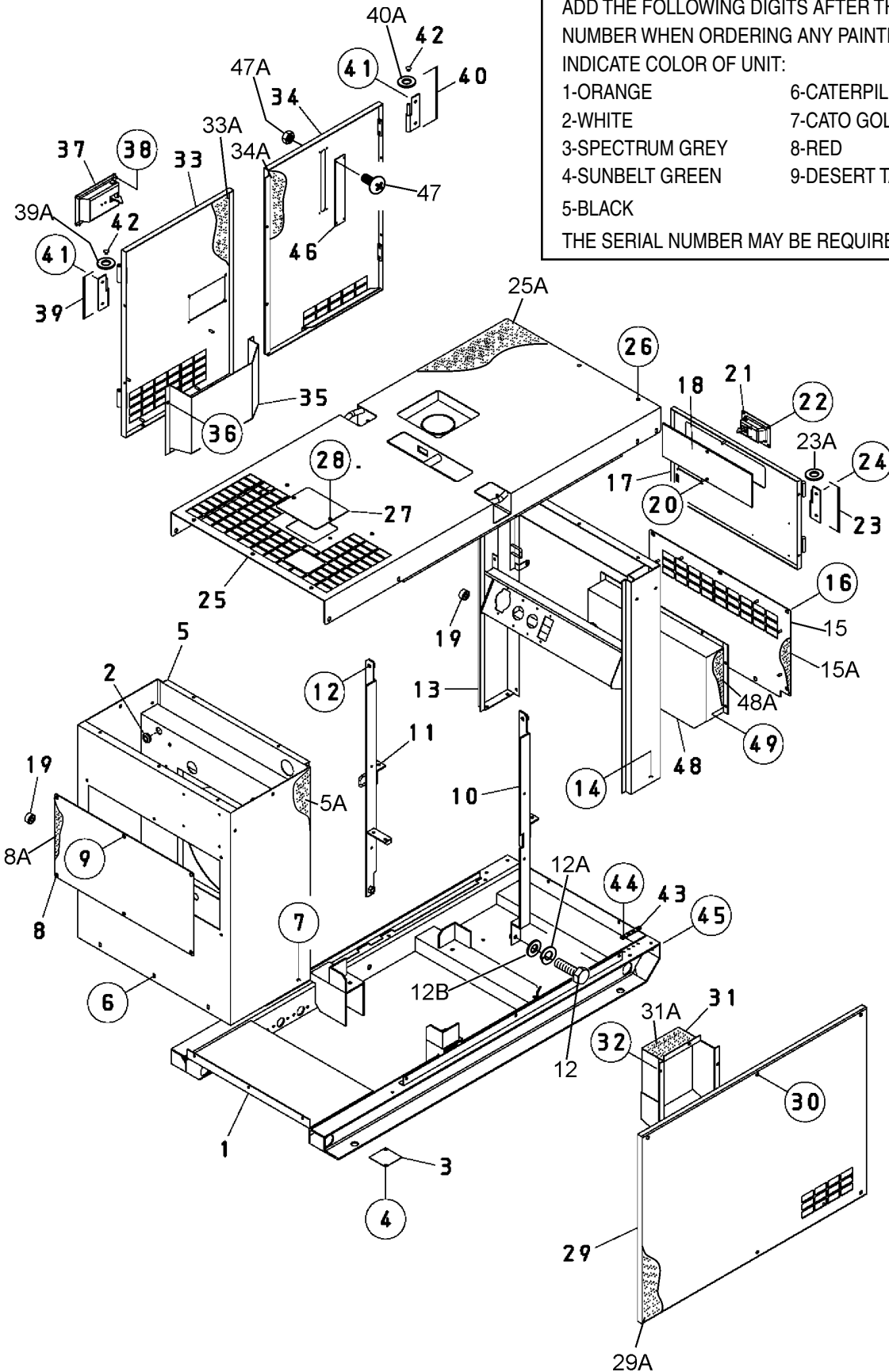

## ENCLOSURE ASSY. (CONTINUED)

<u>NO.</u>	<u>PART NO.</u>	<u>PART NAME</u>	<u>QTY.</u>	<u>REMARKS</u>
34	M0454000503	SIDE DOOR	1	
34A	M0494402304	ACOUSTIC SHEET	1	
35	M0454300604	DUCT	1	
36	0176060030	NUT, FLANGE 6MM.....	4.....	REPLACES P/N 0207006000
37	0605012309	DOOR HANDLE	1	
38	0176060030	NUT, FLANGE 6MM.....	4.....	REPLACES P/N 0207006000
39	M9110100304	HINGE	2	
39A	M9116100004	WASHER	2	
40	M9110100204	HINGE	2	
40A	M9116100004	WASHER	2	
41	0019208020	HEX. HEAD BOLT	8	
42	0845031504	CAP.....	4.....	REPLACES P/N M9310000004
43	M1278200004	PLATE	1	
44	0016906015	HEX. HEAD BOLT	4	
45	0019208020	HEX. HEAD BOLT	1	
46	M0454400004	WINDOW PLATE	1	
47	0027103010	MACHINE SCREW	4	
47A	0207003000	HEX. NUT	4	
48	M0444800003	DUCT	1	
48A	M0444100104	ACOUSTIC SHEET	1	
49	0176060030	NUT, FLANGE 6MM.....	6.....	REPLACES P/N 0207006000

# RUBBER SEALS ASSY.

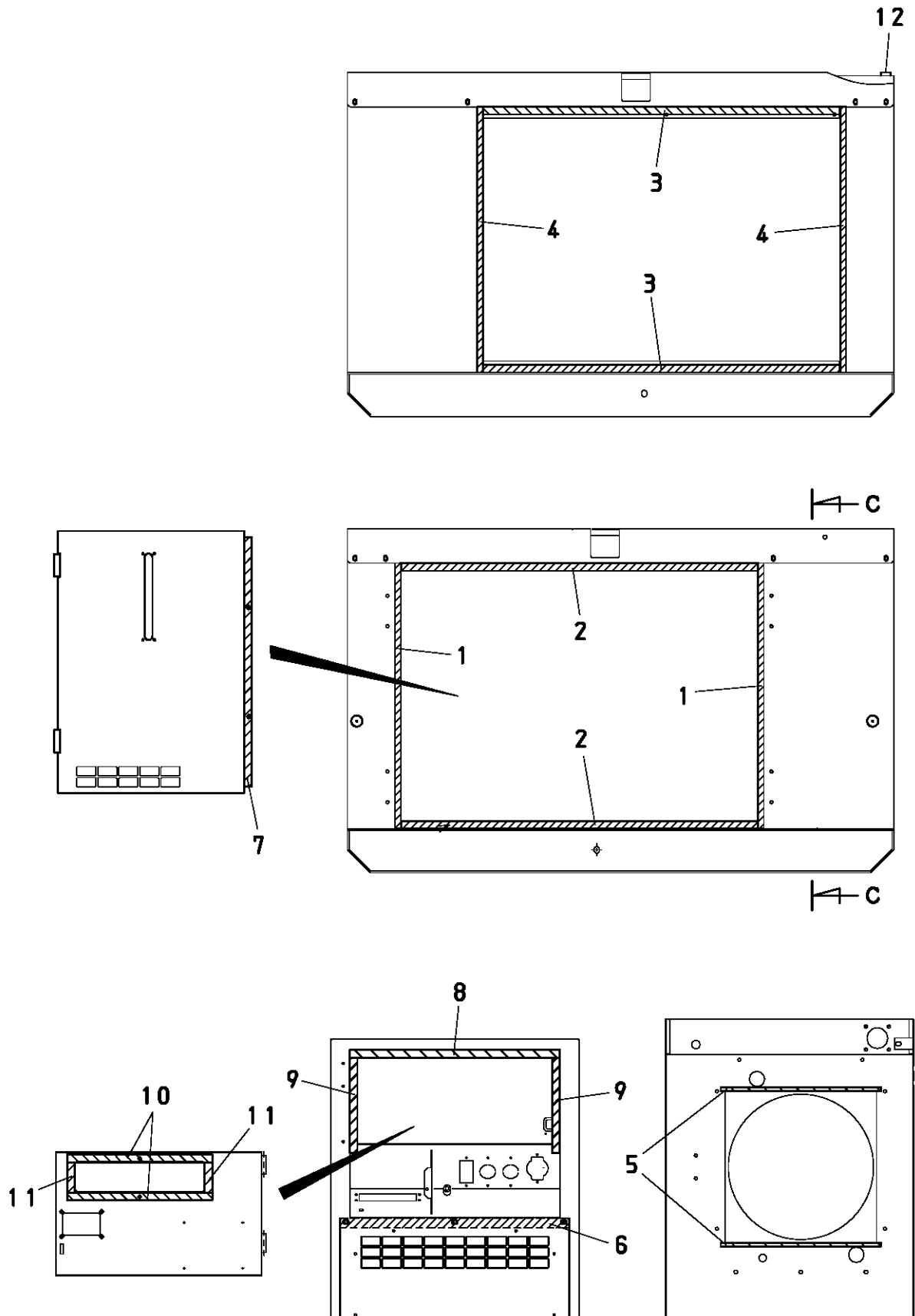

## **RUBBER SEALS ASSY.**

---

<u>NO.</u>	<u>PART NO.</u>	<u>PART NAME</u>	<u>QTY.</u>	<u>REMARKS</u>
1	0229400695	RUBBER SEAL	2	
2	Y0229400950	RUBBER SEAL	2	
3	0221700950	RUBBER SEAL	2	
4	0221700695	RUBBER SEAL	2	
5	0315900475	RUBBER SEAL	2	
6	0229200600	RUBBER SEAL	1	
7	0229400660	RUBBER SEAL	2	
8	0229400550	RUBBER SEAL	1	
9	0229400250	RUBBER SEAL	2	
10	0227500380	RUBBER SEAL	2	
11	0227500080	RUBBER SEAL	2	
12	Y0229200650	RUBBER SEAL	1	

# BATTERY CHARGER ASSY.

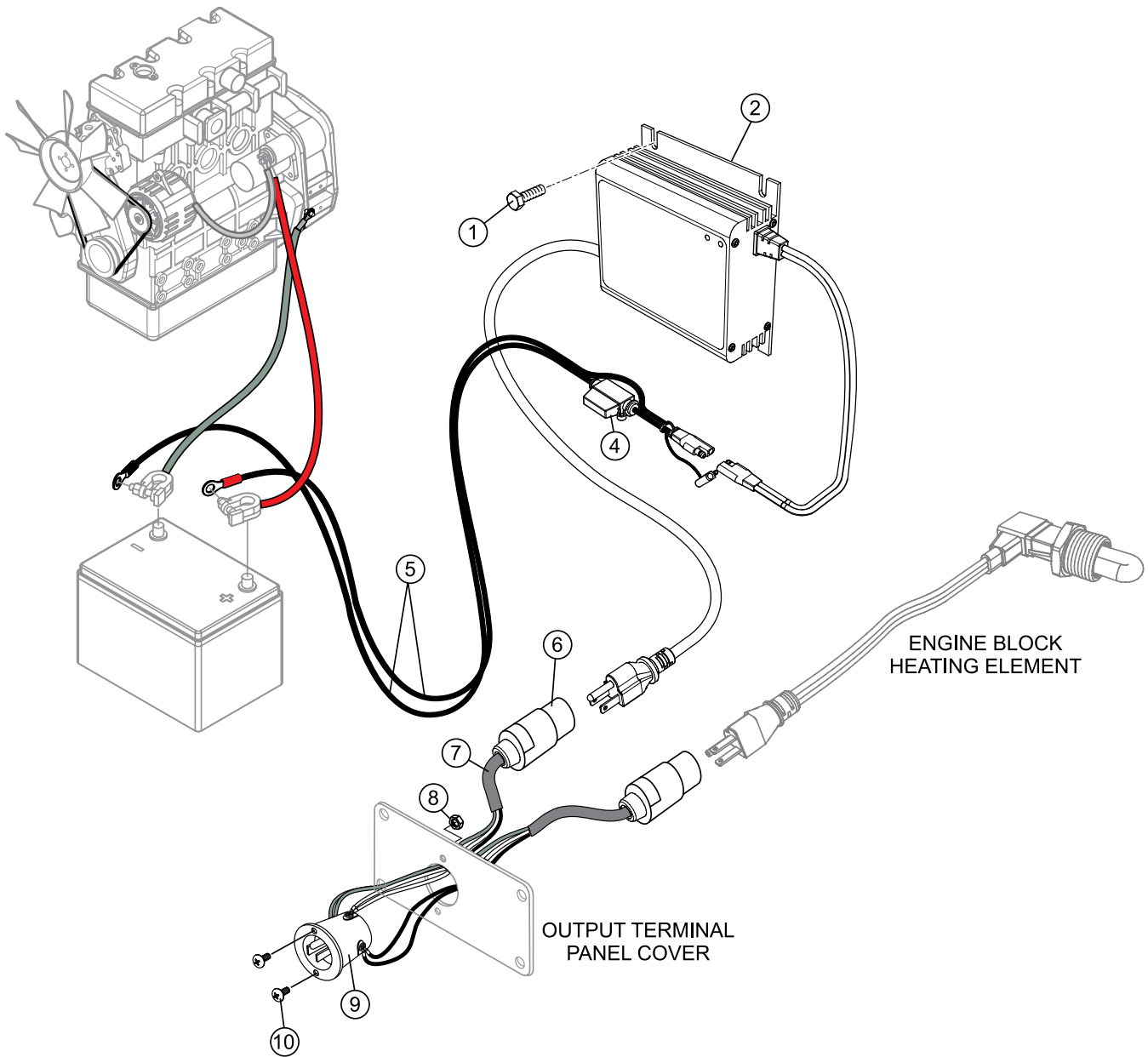

## BATTERY CHARGER ASSY.

---

<u>NO.</u>	<u>PART NO.</u>	<u>PART NAME</u>	<u>QTY.</u>	<u>REMARKS</u>
1		SCREW, 10-24 X 1/2" .....	2.....	OBTAIN LOCALLY
2	LC125002	CHARGER, BATT., FLOAT TYPE, 3A, 12V .....	1.....	INCLUDES ITEMS W/\$
3\$	EE58072	CORD, CHARGE SIDE	1	
4\$	23284-030	FUSE, 3 AMP	2	
5\$	EE58070	CORD, CHARGE, STARTER SIDE	1	
6	HBL5369C	CONNECTOR, 20 AMP, 125V	1	
7	EE56557	CORD, CAROL 3/C 14 AWG .....	AR .....	1PC = 1FT.
8	OEMAA8	HEX NUT, 4MM	2	
9	HBL5278C	INLET FLANGE, NEMA 15A 125V	1	
10	7538070	SCREW, PHILLIPS HD.	2	

# ENGINE BLOCK HEATING ELEMENT ASSY.

---

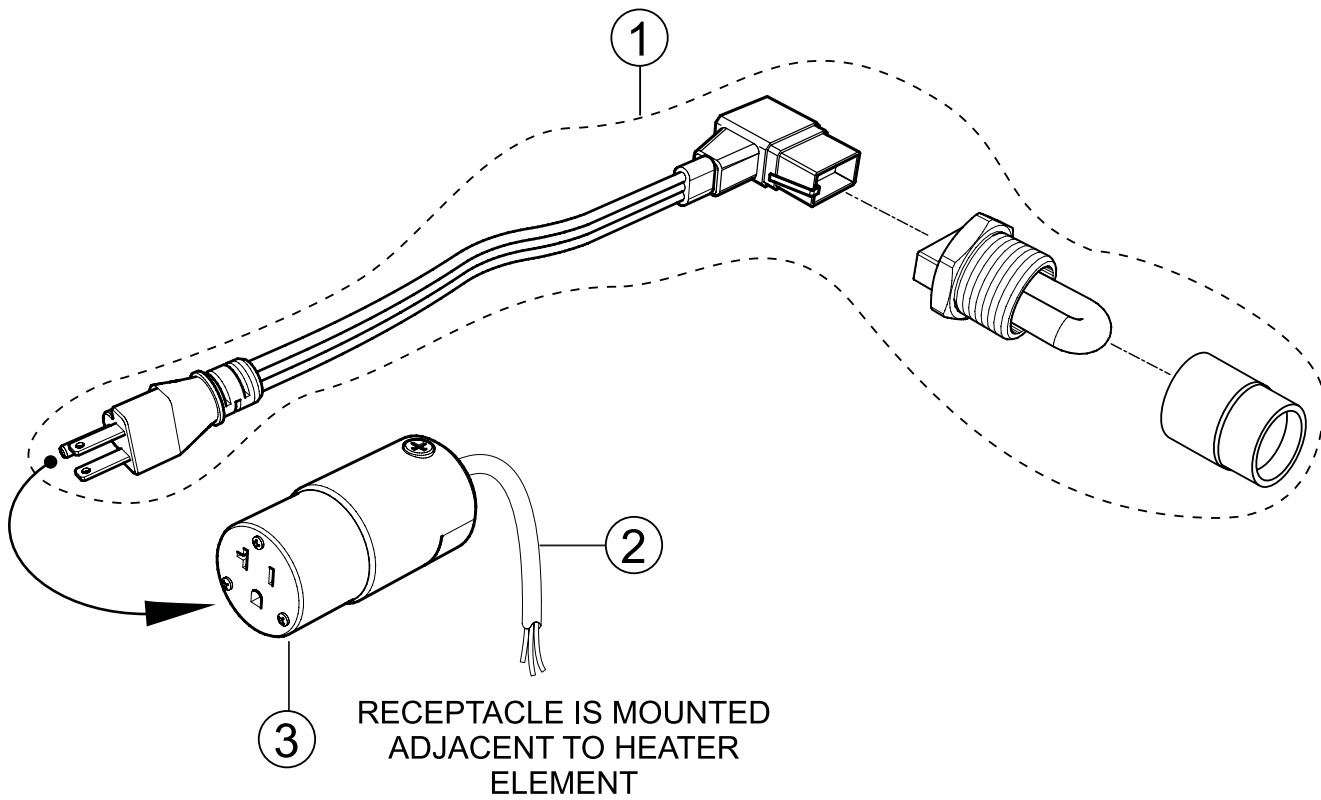



## ENGINE BLOCK HEATING ELEMENT ASSY.

---

1	EE55724	KIT, 110 VOLT, COOLANT HEATER.....1.....INCLUDES ITEMS W/ \$
2	EE56557	CORD, CAROL 3/C 14AWG 90C.....10.....1PC=1FT
3	HBL5369C	CONNECTOR, 20AMP, 125V 1

# NAMEPLATE AND DECALS ASSY.

VIEW-Z

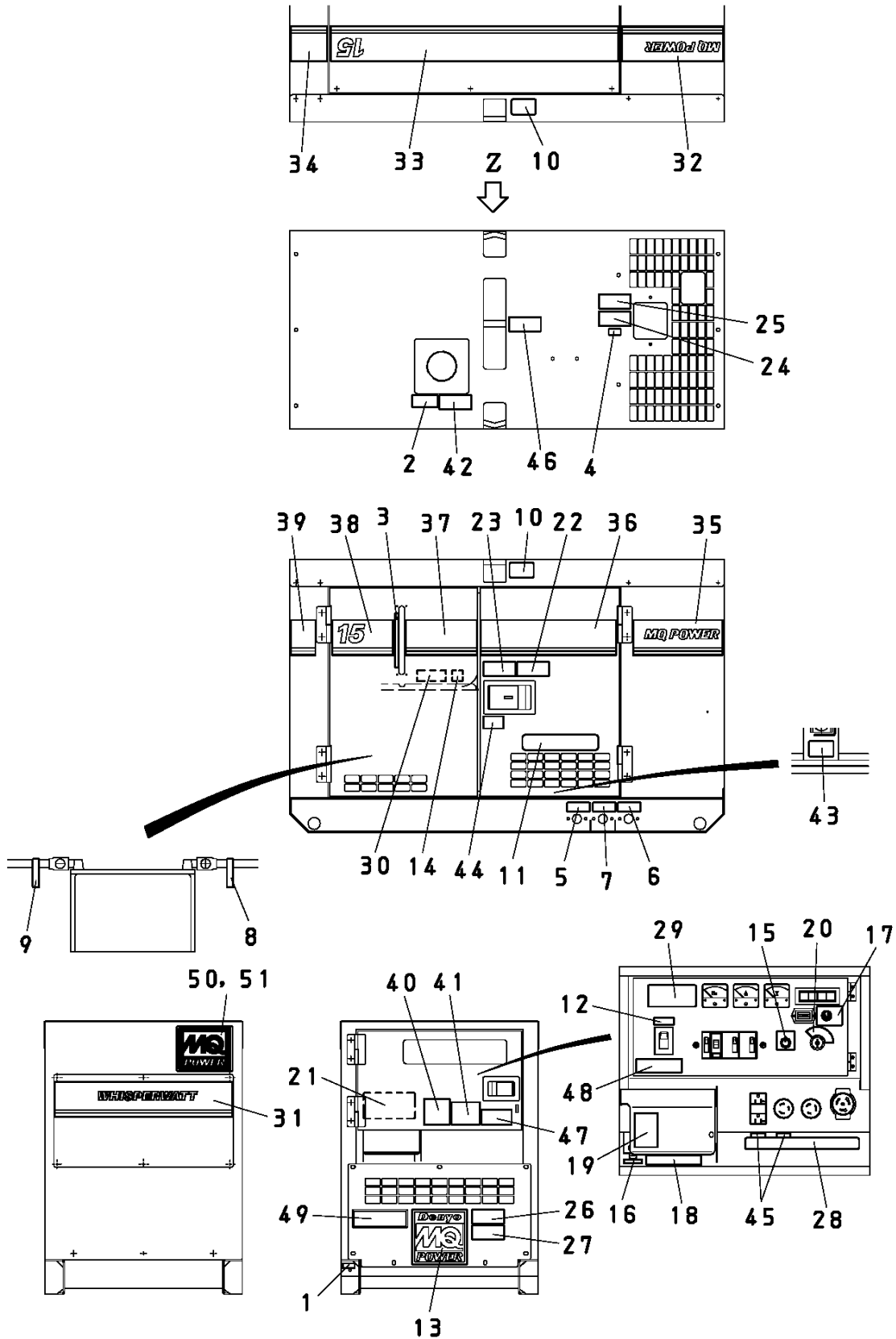

## NAMEPLATE AND DECALS ASSY.

NO.	PART NO.	PART NAME	QTY.	REMARKS
1	M9520000004	DECAL: GROUND .....	1.....	M92000000
2	M9501500004	DECAL: DIESEL FUEL .....	1.....	M90150000
3	M9502500104	DECAL: FUEL GAUGE .....	1.....	M90250010
4	M9500100004	DECAL: WATER .....	1.....	M90010000
5	M9500500104	DECAL: FUEL DRAIN PLUG .....	1.....	M90050010
6	M9500100104	DECAL: WATER DRAIN PLUG .....	1.....	M90010010
7	M9500000004	DECAL: OIL DRAIN PLUG .....	1.....	M90000000
8	M9500300104	DECAL: + .....	1.....	M90030010
9	M9500300004	DECAL: - .....	1.....	M90030000
10	M9512000004	DECAL: SUPPORT HOOK .....	2.....	M91200000
11	M9503000103	DECAL: WATER • OIL CHK. AND FILL DAILY ...	1.....	M90300010
12	M9522000504	DECAL: CIRCUIT BREAKER .....	1.....	M92200050
13	M9511200203	DECAL: MQ POWER .....	1.....	M91120020
14	M9502500004	DECAL: FUEL COCK .....	1.....	M90250000
15	M9522000604	DECAL: VOLTAGE REGULATOR .....	1.....	M92200060
16	M9522001504	DECAL: GROUND FOR G. F. C. I. ....	1.....	M92200150
17	M9501400014	DECAL: SPEED CONTROL SWITCH .....	1.....	M90140001
18	M9522200004	DECAL: AC OUTPUT TERMINAL .....	1.....	M92220000
19	M9522100004	DECAL: DANGER HIGH VOLTAGE .....	1.....	M92210000
20	M9502400004	DECAL: STARTER SWITCH .....	1.....	M90240000
21	M0551000103	DECAL: OPERATING PROCEDURE .....	1.....	M05100010
22	M9510100004	DECAL: CAUTION HOT PARTS .....	1.....	M91010000
23	M9503000004	DECAL: WARNING MOVING PARTS .....	1.....	M90300000
24	M9503100004	DECAL: WARNING HOT COOLANT .....	1.....	M90310000
25	M9503200004	DECAL: WARNING ENGINE EXHAUST .....	1.....	M90320000
26	M9520100503	DECAL: WARNING .....	1.....	M91010020
27	M9520100503	DECAL: WARNING .....	1.....	M92010010 REPLACES P/N M9510100204 REPLACES P/N M9520100104
28	M0552000103	DECAL: AC POWER OUTPUT .....	1.....	M05200010
29	M9520100004	DECAL: WARNING ELECT. SHOCK HAZ. ....	1.....	M92010000
30	M9504300004	DECAL: POISON/DANGER .....	1.....	M90430000
31	M0562100003	STRIPE: WHISPERWATT	1	
32	M0561100804	STRIPE: MQ POWER	1	
33	M0561101404	STRIPE	1	
34	M0561100304	STRIPE	1	
35	M0561100904	STRIPE	1	
36	M0561101304	STRIPE	1	
37	M0561101204	STRIPE	1	
38	M0561101504	STRIPE	1	
39	M0561100404	STRIPE	1	
40	M9503200104	DECAL: DANGER .....	1.....	M90320010
41	M9531100004	DECAL: DANGER ELECTROCUTION .....	1.....	M93110000
42	M9503500004	DECAL: WARNING, FIRE .....	1.....	M90350000

# NAMEPLATE AND DECALS ASSY.

VIEW-Z

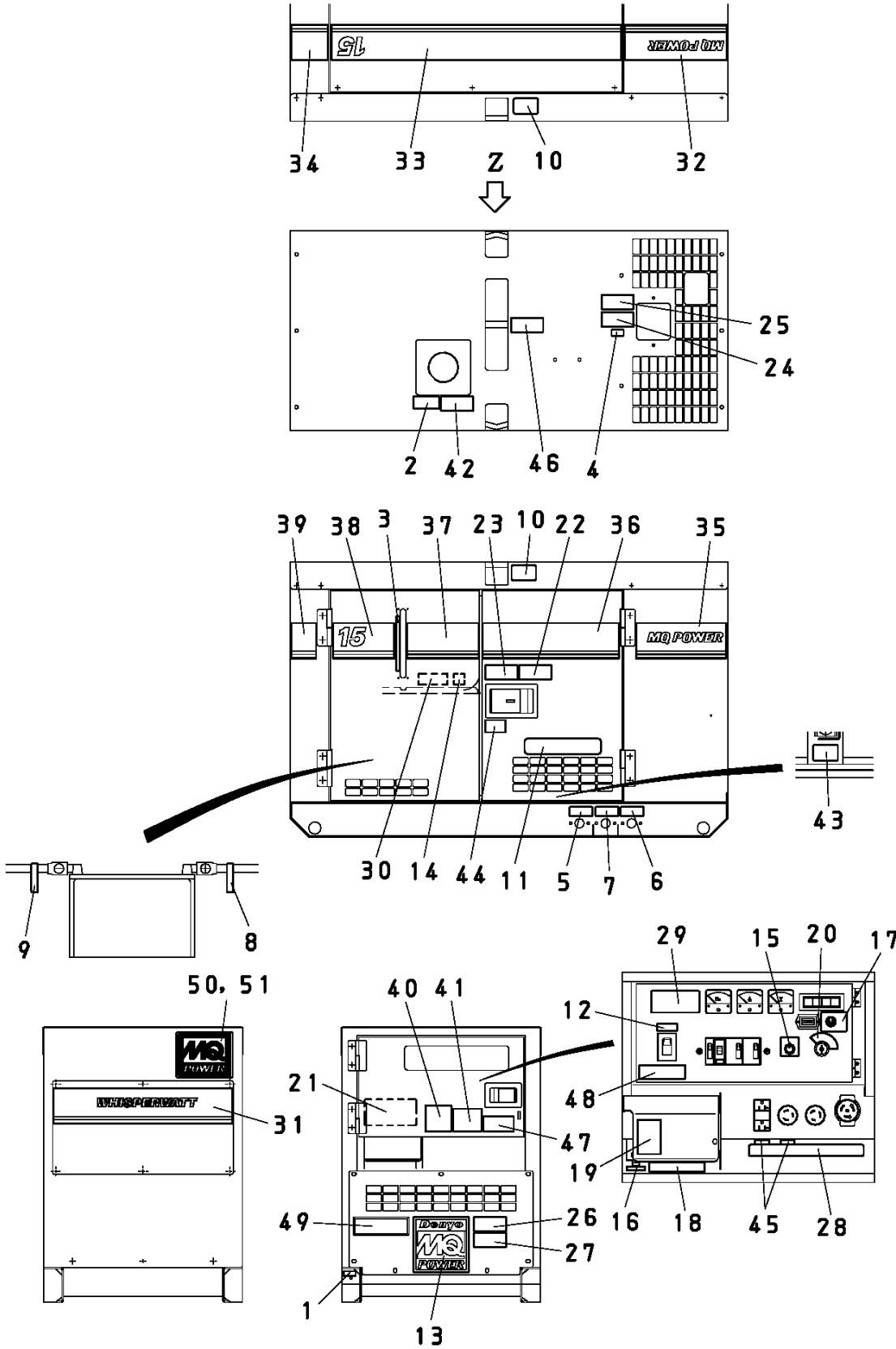

## NAMEPLATE AND DECALS ASSY.

<u>NO.</u>	<u>PART NO.</u>	<u>PART NAME</u>	<u>QTY.</u>	<u>REMARKS</u>
43	M9504000004	DECAL: WARNING, OIL REFUELING.....	1.....	M90400000
44	M9504400004	DECAL: CAUTION .....	1.....	M90440000
45	M9521000104	DECAL: GFCI.....	2.....	M92100010
46	M0551000304	DECAL: MAXIMUM CAPACITY OF LIFTING ....	1.....	M05100030
47	920214100	DECAL: WARNING START FIRES .....	1.....	M90420000 REPLACES P/N M9504200004
48	M0561000104	DECAL: MQ STICKER CONTROL PANEL.....	1.....	M06100010
49	M9511200103	TIER 4F.....	1.....	M91120010
50	0600500092	EMBLEM	1	
51	0021106015	MACHINE SCREW	4	

# TERMS AND CONDITIONS OF SALE — PARTS

## PAYMENT TERMS

Terms of payment for parts are net 30 days.

## FREIGHT POLICY

All parts orders will be shipped collect or prepaid with the charges added to the invoice. All shipments are F.O.B. point of origin. Multiquip's responsibility ceases when a signed manifest has been obtained from the carrier, and any claim for shortage or damage must be settled between the consignee and the carrier.

## MINIMUM ORDER

The minimum charge for orders from Multiquip is \$15.00 net. Customers will be asked for instructions regarding handling of orders not meeting this requirement.

## RETURNED GOODS POLICY

Return shipments will be accepted and credit will be allowed, subject to the following provisions:

1. A Returned Material Authorization must be approved by Multiquip prior to shipment.
2. To obtain a Return Material Authorization, a list must be provided to Multiquip Parts Sales that defines item numbers, quantities, and descriptions of the items to be returned.
  - a. The parts numbers and descriptions must match the current parts price list.
  - b. The list must be typed or computer generated.
  - c. The list must state the reason(s) for the return.
  - d. The list must reference the sales order(s) or invoice(s) under which the items were originally purchased.
  - e. The list must include the name and phone number of the person requesting the RMA.
3. A copy of the Return Material Authorization must accompany the return shipment.
4. Freight is at the sender's expense. All parts must be returned freight prepaid to Multiquip's designated receiving point.

5. Parts must be in new and resalable condition, in the original Multiquip package (if any), and with Multiquip part numbers clearly marked.
6. The following items are not returnable:
  - a. Obsolete parts. (If an item is in the price book and shows as being replaced by another item, it is obsolete.)
  - b. Any parts with a limited shelf life (such as gaskets, seals, "O" rings, and other rubber parts) that were purchased more than six months prior to the return date.
  - c. Any line item with an extended dealer net price of less than \$5.00.
  - d. Special order items.
  - e. Electrical components.
  - f. Paint, chemicals, and lubricants.
  - g. Decals and paper products.
  - h. Items purchased in kits.
7. The sender will be notified of any material received that is not acceptable.
8. Such material will be held for five working days from notification, pending instructions. If a reply is not received within five days, the material will be returned to the sender at his expense.
9. Credit on returned parts will be issued at dealer net price at time of the original purchase, less a 15% restocking charge.
10. In cases where an item is accepted, for which the original purchase document can not be determined, the price will be based on the list price that was effective twelve months prior to the RMA date.
11. Credit issued will be applied to future purchases only.

## PRICING AND REBATES

Prices are subject to change without prior notice. Price changes are effective on a specific date and all orders received on or after that date will be billed at the revised price. Rebates for price declines and added charges for price increases will not be made for stock on hand at the time of any price change.

Multiquip reserves the right to quote and sell direct to Government agencies, and to Original Equipment Manufacturer accounts who use our products as integral parts of their own products.

## SPECIAL EXPEDITING SERVICE

A \$35.00 surcharge will be added to the invoice for special handling including bus shipments, insured parcel post or in cases where Multiquip must personally deliver the parts to the carrier.

## LIMITATIONS OF SELLER'S LIABILITY

Multiquip shall not be liable hereunder for damages in excess of the purchase price of the item with respect to which damages are claimed, and in no event shall Multiquip be liable for loss of profit or good will or for any other special, consequential or incidental damages.

## LIMITATION OF WARRANTIES

No warranties, express or implied, are made in connection with the sale of parts or trade accessories nor as to any engine not manufactured by Multiquip. Such warranties made in connection with the sale of new, complete units are made exclusively by a statement of warranty packaged with such units, and Multiquip neither assumes nor authorizes any person to assume for it any other obligation or liability whatever in connection with the sale of its products. Apart from such written statement of warranty, there are no warranties, express, implied or statutory, which extend beyond the description of the products on the face hereof.

Effective: February 22, 2006



# PARTS MANUAL

## HERE'S HOW TO GET HELP

PLEASE HAVE THE MODEL AND SERIAL  
NUMBER ON-HAND WHEN CALLING

### UNITED STATES

#### ***Multiquip Corporate Office***

18910 Wilmington Ave.  
Carson, CA 90746  
Contact: mq@multiquip.com

Tel. (800) 421-1244  
Fax (310) 537-3927

#### ***Service Department***

800-421-1244  
310-537-3700

#### ***Technical Assistance***

800-478-1244 Fax: 310-943-2238

#### ***MQ Parts Department***

800-427-1244  
310-537-3700

Fax: 800-672-7877

#### ***Warranty Department***

800-421-1244  
310-537-3700

Fax: 310-943-2249

### CANADA

#### ***Multiquip***

4110 Industriel Boul.  
Laval, Quebec, Canada H7L 6V3  
Contact: infocanda@multiquip.com

Tel: (450) 625-2244  
Tel: (877) 963-4411  
Fax: (450) 625-8664

### UNITED KINGDOM

#### ***Multiquip (UK) Limited Head Office***

Unit 2, Northpoint Industrial Estate,  
Globe Lane,  
Dukinfield, Cheshire SK16 4UJ  
Contact: sales@multiquip.co.uk

Tel: 0161 339 2223  
Fax: 0161 339 3226

© COPYRIGHT 2017, MULTIQUIP INC.

Multiquip Inc, the MQ logo and the MQ Power logo are registered trademarks of Multiquip Inc. and may not be used, reproduced, or altered without written permission. All other trademarks are the property of their respective owners and used with permission.

This manual MUST accompany the equipment at all times. This manual is considered a permanent part of the equipment and should remain with the unit if resold.

The information and specifications included in this publication were in effect at the time of approval for printing. Illustrations, descriptions, references and technical data contained in this manual are for guidance only and may not be considered as binding. Multiquip Inc. reserves the right to discontinue or change specifications, design or the information published in this publication at any time without notice and without incurring any obligations.

Your Local Dealer is:

Manufactured for  
MQ Power Inc.  
by  
DENYO CO., LTD, JAPAN

