



# DCA300SSJU4F3PB

Generator

## WhisperWatt™

Prime Rating — 240 kW (300 kVA)

Standby Rating — 264 kW (330 kVA)

3-Phase, 50/60 Hertz, 0.8 PF

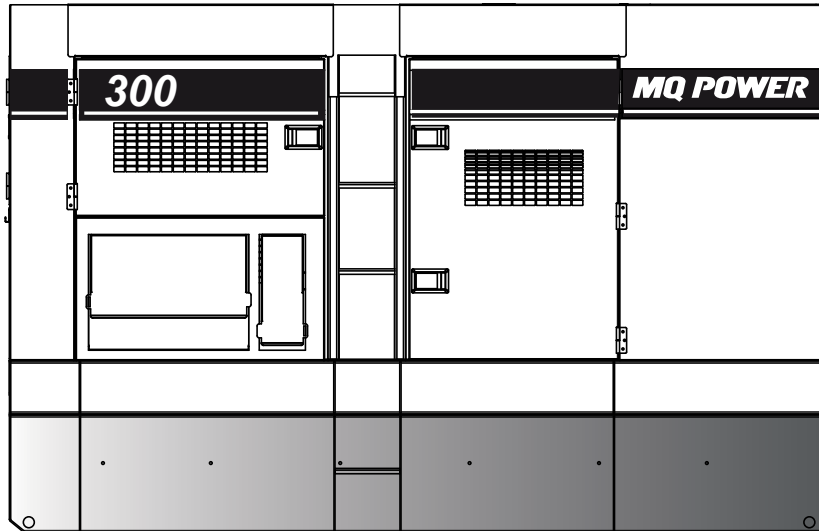

### STANDARD FEATURES

- Heavy duty, 4-cycle, electronic direct injection, turbocharged, charged air cooler, variable speed fan, 1000W block heater, diesel engine provides maximum reliability.
- EPA emissions certified — Tier 4 Final emissions compliant.
- Microprocessor engine control system maintains frequency to  $\pm 0.25\%$ .
- Full load acceptance of standby nameplate rating in a single step.
- Fuel/water separator removes condensation from fuel for extended engine life. Panel mounted alarm light included.
- Sound attenuated, weather resistant, steel housing provides operation at 72 dB(A) at 23 feet. Fully lockable enclosure allows safe unattended operation.
- E-coat primer and powder coat paint provides durability and weather protection.
- UN31A internal fuel tank with direct reading fuel gauges are standard.
- Spill Containment — Bunded design protects environment by capturing up to 123% of engine fluids.
- Manual 3-way fuel valve allows external fuel supply to be connected for longer runtime.
- Brushless alternator reduces service and maintenance requirements and meets temperature rise standards for Class F insulation systems.
  - Open delta alternator design provides virtually unlimited excitation for maximum motor starting capability.
  - Automatic voltage regulator (AVR) provides precise regulation.
- Automatic safety shutdown system monitors the water temperature, engine oil pressure, low coolant, low DEF, overspeed, and overcrank. Warning lights indicate abnormal conditions.
- Fully covered power panel. Three-phase terminals and single phase receptacles allow fast and convenient hookup for most applications including temporary power boxes, tools and lighting equipment. All are NEMA standard.
- Basler DGC2020HD microprocessor-based digital generator controller with integrated genset-to-genset (isolated bus) paralleling.
  - Onboard Synchronization and kW/kVAR load sharing. Dual Ethernet ports for Inter-Genset communication.
  - High visibility backlit LCD display.
  - Operational temperature range of  $-40^{\circ}$  to  $70^{\circ}$  C ( $-40^{\circ}$  to  $158^{\circ}$  F).
  - Remote 2-wire start/stop control.
  - Metered power output parameters include:
    - Voltage
    - Amperage
    - Kilowatts
    - Kilovolt amps
    - Power Factor
    - Hertz
  - Modbus interface for gauge panel and expansion options.)
  - Engine monitoring data over J1939. Modbus over RS485 for SCADA Interface.
- Dual frequency capability allows for operation at 50 Hz or 60 Hz.
- Main line circuit breaker, 800 amps, 100% rated with LSI set points.
- Cam-Lok connectors (2 sets) provides quick disconnect alternative to bolt-on components.
- Emergency stop switch — when manually activated, shuts down generator in the event of an emergency.



# DCA300SSJU4F3PB

## Generator

### SPECIFICATIONS

#### Generator Specifications

Design	Revolving field, self-ventilated Drip-proof, single bearing
Armature Connection	Star with Neutral
Phase	3
Standby Output	264 KW (330 KVA)
Prime Output	240 KW (300 KVA)
3Ø Voltage (L-L-L-N) Voltage Change-Over Bus Bars at 3Ø 240/139	208Y/120, 220Y/127, 240Y/139
3Ø Voltage (L-L-L-N) Voltage Change-Over Bus Bars at 3Ø 480/277	416Y/240, 440Y/254, 480Y/277
1Ø Voltage (L-L-L-N) Voltage Change-Over Bus Bars at 1Ø 240/120)	N/A
Power Factor	0.8
Voltage Regulation (No load to full load)	±0.5%
Generator RPM	1800
Frequency	50/60 Hz
Winding Pitch	2/3
No. of Poles	4
Excitation	Brushless with AVR
Frequency Regulation: No Load to Full Load	Isochronous under varying loads from no load to 100% rated load
Frequency Regulation: Steady State	±0.25% of mean value for constant loads from no load to full load.
Insulation	Class F
Sound Level dB(A) Full load at 23 feet	72

#### Engine Specifications

Make / Model	John Deere / 6090HFG06
Emissions	EPA Tier 4 Final Certified
Starting System	Electric
Design	4-cycle, water cooled, direct injection, turbocharged, charged air cooled, EGR, DOC, and SCR.
Displacement	549.2 in <sup>3</sup> (9.0 liters)
No. cylinders	6
Bore x Stroke	4.64 x 5.34 in. (118.4 x 136 mm)
Gross Engine Power Output	437 hp (326 kW)
BMEP	320 psi (2212 kPa)
Piston Speed	1606 ft/min (8.16 m/s)
Compression Ratio	16.0 : 1
Engine Speed	1800 rpm
Overspeed Limit	2070 rpm
Oil Capacity	9.3 gallons (35 liters)
Battery	12V 430Ah x 1

#### Fuel System

Recommended Fuel	ASTM-D975-No.1 & No.2-D*	
Maximum Fuel Flow (per hour)	43 gallons (163.1 liters)	
Maximum Inlet Restriction (Hg)	5.9 in (150 mm)	
Fuel Tank Capacity	430.6 gallons (1630 liters)	
<b>Fuel Consumption</b>	<b>gph</b>	<b>lph</b>
At full load	16.7	63.2
At 3/4 load	12.5	47.4
At 1/2 load	8.9	33.8
At 1/4 load	5.8	21.9
DEF Tank Capacity	29.8 gallons (112.8 liters)	

\* - Use ultra-low sulfur diesel fuel.

#### Cooling System

Fan Load	26.8 hp (20 kW)
Coolant Capacity (with radiator)	17.7 gallons (67 liters)
Coolant Flow Rate (per minute)	102 gallons (385 liters)
Heat Rejection to Coolant (per minute)	10,473 Btu (11.05 MJ)
Maximum Coolant Friction Head	8.7 psi (60 kPa)
Maximum Coolant Static Head	78.7 ft. (24.1 m)
Ambient Temperature Rating	104°F (40°C)

#### Air

Combustion Air	742 cfm (21.0 m <sup>3</sup> /min)
Maximum Air Cleaner Restriction	25 in. H <sub>2</sub> O (6.25 kPa)
Alternator Cooling Air	2797 cfm (79.0 m <sup>3</sup> /min)
Radiator Cooling Air	11,800 cfm (334.1 m <sup>3</sup> /min)

#### Exhaust System

Gas Flow (full load)	1,448 cfm (41.0 m <sup>3</sup> /min)
Gas Temperature	831°F (444°C)
Maximum Back Pressure	116 in. H <sub>2</sub> O (29 kPa)

#### Amperage

Rated Voltage	Maximum Amps
1Ø 120 Volt	666.7 Amps (4 wire)
1Ø 240 Volt	333.3 Amps (4 wire)
3Ø 208 Volt	722 Amps
3Ø 240 Volt	722 Amps
3Ø 480 Volt	360 Amps
Main Line Circuit Breaker Rating	800 Amps
Over Current Relay Trip Set Point 480V Mode Only	361 Amps

### WARRANTY\*

#### John Deere Engine

12 months from date of purchase with unlimited hours or 24 months and prior to the accumulation of 2000 hours (whichever occurs first).

#### Generator

24 months from date of purchase or 2000 hours (whichever occurs first).

#### Trailer

12 months excluding normal wear items.

\*Refer to the express written, one-year limited warranty sheet for additional information.

#### NOTICE

Specifications sheet is subject to change and is not intended for use in installation design.



# DCA300SSJU4F3PB

## Generator

### MQ POWER DECIBEL LEVELS

Our soundproof housing allows substantially lower operating noise levels than competitive designs. WhisperWatts are at home on construction sites, in residential neighborhoods, and at hospitals — just about anywhere.

- 90 — Subway / truck traffic
- 80 — Average city traffic
- 72 — **WhisperWatt at 23 feet**
- 70 — Inside car at 60 mph
- 60 — Air conditioner at 20 feet
- 50 — Normal conversation



### GENERATOR OUTPUT PANEL

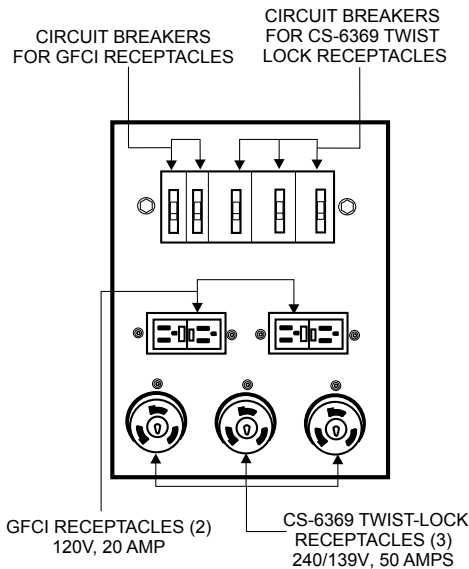

### OPTIONAL GENERATOR FEATURES

- **PowerBalance™** — designed to assist generators when operating under low temperature and/or low load conditions to insure peak performance.
- **Battery Charger** — provides fully automatic and self-adjusting charging to the generator's battery system.
- **Crankcase Vent Blanket with Heating Element** — insures proper crankcase ventilation in freezing conditions. (Unit comes standard with a non-heated crankcase blanket)
- **Trailer Mounted Package** — meets National Highway Traffic Safety Administration (NHTSA) regulations. Trailer is equipped with electronic or surge brakes on all axles.

### OPTIONAL CONTROL FEATURES

- **Audible Alarm** alerts operator of abnormal conditions.

### OPTIONAL FUEL CELL FEATURES

(For non-trailer mount applications)

- **Sub-base Fuel Cells (double wall)** — additional fuel cell for extended runtime operation. Contains a leak sensor, low fuel level switch, and a secondary containment tank. UL142 listed.
- 12 hours of minimum run time.
- 24 hours of minimum run time.

### OPTIONAL OUTPUT CONNECTIONS

- **Pin and Sleeve Connectors** — provides industry standard connectors for all voltage requirements.
- **Output Cable** — available in any custom length and size configuration.



# DCA300SSJU4F3PB

Generator

## SKID-MOUNT DIMENSIONS

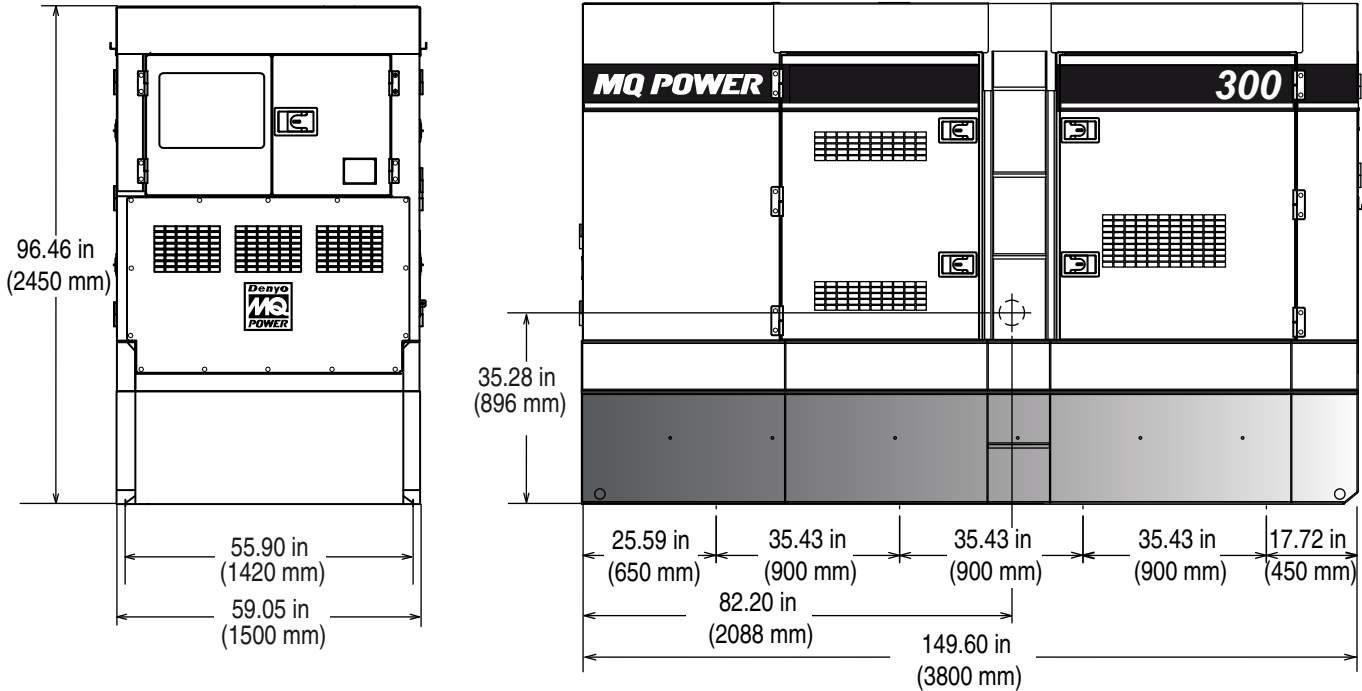

## TRAILER-MOUNT DIMENSIONS

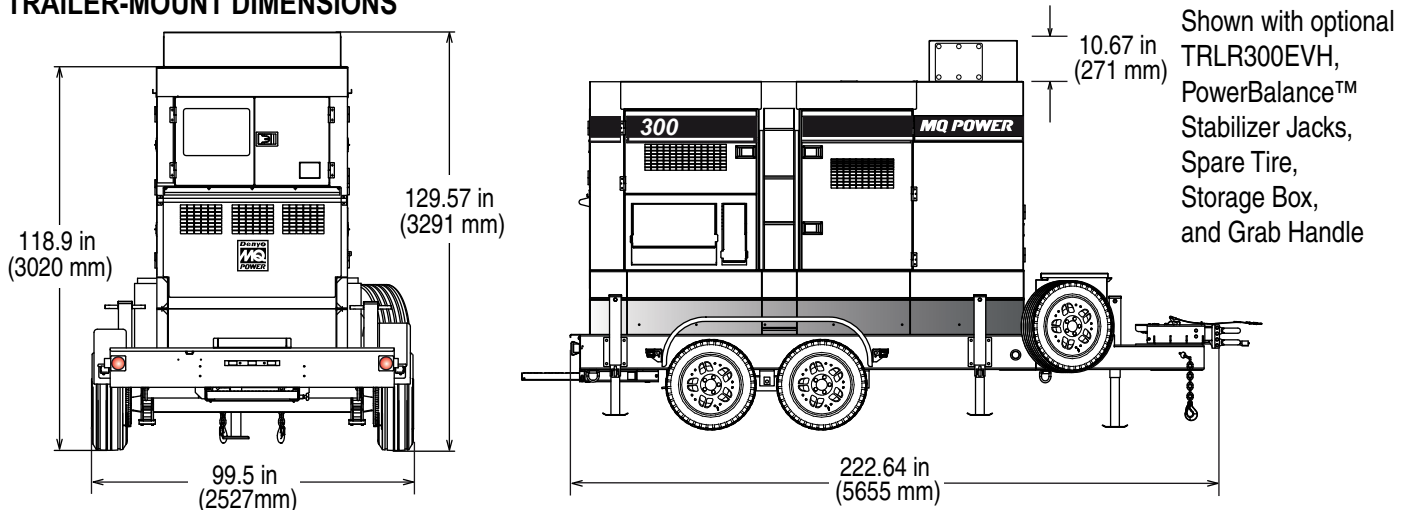

### DCA300SSJU4F3PB Weights\*

Dry Weight	11,155 lbs. (5,060 kg)
Wet Weight	14,815 lbs. (6,720 kg)
Max. Lifting Point Capacity	19,000 lbs. (8,618 kg)

### DCA300SSJU4F3PB and TRLR300EV Weights\*

Dry Weight (with TRLR300EV)	14,075 lbs. (6,384 kg)
Wet Weight (with TRLR300EV)	17,735 lbs. (8,044 kg)

\* Weights do not include options.

Generator can be placed on MQ Trailer Model TRLR300EV (H/E).

### NOTICE

Features and Specifications are subject to change without notice.



MULTIQUIP  
 6141 Katella Avenue Suite 200  
 Cypress, CA 90630  
 310-537-3700  
 E-MAIL: [mq@multiquip.com](mailto:mq@multiquip.com)  
 WEBSITE: [www.multiquip.com](http://www.multiquip.com)