

PARTS MANUAL



WHISPERWATT™ SERIES MODEL DCA70SSJU4F 60HZ GENERATOR (JOHN DEERE 4045HFG04 DIESEL ENGINE)

PARTS LIST NO. M2871300204J

Revision #5 (02/09/24)

To find the latest revision of this publication or associated operation manual, visit our website at: www.mqpower.com



THIS MANUAL MUST ACCOMPANY THE EQUIPMENT AT ALL TIMES.

DCA70SSJU4F 60Hz Generator

Explanation Of Code In Remarks Column.....	4
Suggested Spare Parts	5

Component Drawings

Generator Assembly	6-7
Control Box Assembly	8-13
Engine And Radiator Assembly	14-17
Output Terminal Assembly	18-21
Battery Assembly	22-23
Muffler Assembly	24-25
Plumbing Assembly	26-27
Fuel Tank Assembly	28-29
Enclosure Assembly	30-35
Rubber Seals Assembly	36-37
Battery Charger Assembly	38-39
Water Heating Element Assembly (Option)	40-41
Nameplate And Decals Assembly.....	42-45

NOTICE

Specifications and part numbers are subject to change without notice.

EXPLANATION OF CODE IN REMARKS COLUMN

The following section explains the different symbols and remarks used in the Parts section of this manual. Use the help numbers found on the back page of the manual if there are any questions.

NOTICE

The contents and part numbers listed in the parts section are subject to change without notice. Multiquip does not guarantee the availability of the parts listed.

SAMPLE PARTS LIST

NO.	PART NO.	PART NAME	QTY.	REMARKS
1	12345	BOLT	1	INCLUDES ITEMS W/%
2%		WASHER, 1/4 IN.		NOT SOLD SEPARATELY
2%	12347	WASHER, 3/8 IN. ...	1	MQ-45T ONLY
3	12348	HOSE	A/R	MAKE LOCALLY
4	12349	BEARING	1	S/N 2345B AND ABOVE

NO. Column

Unique Symbols — All items with same unique symbol (@, #, +, %, or >) in the number column belong to the same assembly or kit, which is indicated by a note in the “Remarks” column.

Duplicate Item Numbers — Duplicate numbers indicate multiple part numbers, which are in effect for the same general item, such as different size saw blade guards in use or a part that has been updated on newer versions of the same machine.

NOTICE

When ordering a part that has more than one item number listed, check the remarks column for help in determining the proper part to order.

PART NO. Column

Numbers Used — Part numbers can be indicated by a number, a blank entry, or TBD.

TBD (To Be Determined) is generally used to show a part that has not been assigned a formal part number at the time of publication.

A blank entry generally indicates that the item is not sold separately or is not sold by Multiquip. Other entries will be clarified in the “Remarks” Column.

QTY. Column

Numbers Used — Item quantity can be indicated by a number, a blank entry, or A/R.

A/R (As Required) is generally used for hoses or other parts that are sold in bulk and cut to length.

A blank entry generally indicates that the item is not sold separately. Other entries will be clarified in the “Remarks” Column.

REMARKS Column

Some of the most common notes found in the “Remarks” Column are listed below. Other additional notes needed to describe the item can also be shown.

Assembly/Kit — All items on the parts list with the same unique symbol will be included when this item is purchased.

Indicated by:

“INCLUDES ITEMS W/(unique symbol)”

Serial Number Break — Used to list an effective serial number range where a particular part is used.

Indicated by:

“S/N XXXXX AND BELOW”

“S/N XXXX AND ABOVE”

“S/N XXXX TO S/N XXX”

Specific Model Number Use — Indicates that the part is used only with the specific model number or model number variant listed. It can also be used to show a part is NOT used on a specific model or model number variant.

Indicated by:

“XXXXX ONLY”

“NOT USED ON XXXX”

“Make/Obtain Locally” — Indicates that the part can be purchased at any hardware shop or made out of available items. Examples include battery cables, shims, and certain washers and nuts.

“Not Sold Separately” — Indicates that an item cannot be purchased as a separate item and is either part of an assembly/kit that can be purchased, or is not available for sale through Multiquip.

SUGGESTED SPARE PARTS

DCA70SSJU4F PORTABLE GENERATOR WITH JOHN DEERE 4045HFG04 DIESEL ENGINE

1 to 3 units

Qty.	P/N	Description
1.....	M2311500003.....	RADIATOR HOSE, UPPER
1.....	M2311500103.....	RADIATOR HOSE, LOWER
5.....	RE504836.....	CARTRIDGE, OIL FILTER
5.....	RE551507.....	FUEL FILTER ELEMENT (PRIMARY)
5.....	RE551508.....	FUEL FILTER ELEMENT (SECONDARY)
5.....	RE562696.....	SEAL KIT (FUEL FILTER)
5.....	RE540710.....	BLOWBY FILTER ELEMENT
2.....	.0605505070.....	FUEL TANK CAP
5.....	.0602046365.....	ELEMENT, AIR CLEANER
1.....	R533597.....	FAN BELT
1.....	.0601808803.....	CIRCUIT BREAKER, 1P 20A
1.....	.0601808804.....	CIRCUIT BREAKER, 2P 50A
1.....	LY2DUS12VDC.....	RELAY
2.....	.0601806643.....	FUSE, 15A
2.....	.0601806647.....	FUSE, 25A
2.....	Y0601806683.....	FUSE, 250V 8A

NOTICE

Part numbers on this Suggested Spare Parts list may supersede/replace the part numbers shown in the following parts lists.

GENERATOR ASSY.

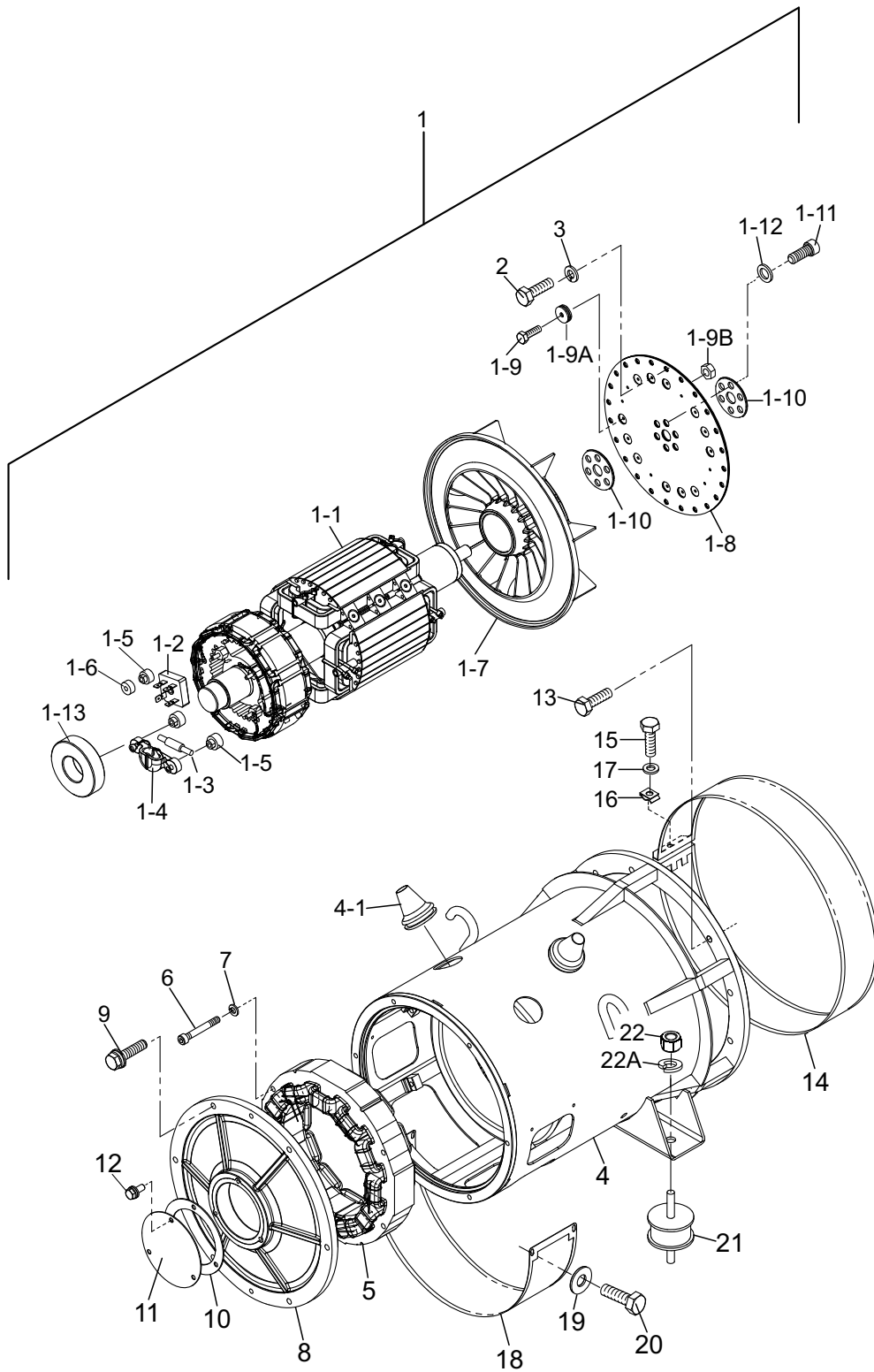

GENERATOR ASSY.

<u>NO.</u>	<u>PART NO.</u>	<u>PART NAME</u>	<u>QTY.</u>	<u>REMARKS</u>
1	B5110101002	ROTOR ASSY.....	1	INCLUDES ITEMS W/#
1-1#		FIELD ASSY.	1	
1-2#	0601820083	RECTIFIER	3	
1-3#	0601822664	ZNR	1	
1-4#	B3120100804	HOLDER	1	
1-5#	B3120100704	INSULATOR WASHER	5	
1-6#	B3120100604	INSULATOR WASHER	3	
1-7#	B3111100603	FAN	1	
1-8#	B2163100004	COUPLING DISK.....	3	PURCHASE IT. 1-9 AS A SET
1-9	Y0019104016	HEX. HEAD BOLT	1	
1-9A	B2163700004	BALANCING WEIGHT	1	
1-9B	Y0204104000	NUT	1	
1-10#	B3163200104	COUPLING WASHER	2	
1-11#	0342612030	HEX. SOCKET HEAD CAP SCREW	6	
1-12#	0046512000	WASHER, FLAT	6	
1-13#	0071906309	BEARING	1	
2	0343204080	HEX. HEAD BOLT	8	
3	EM923344	WASHER, LOCK.....	8	REPLACES P/N 0043604000
4	B5130000303	STATOR ASSY.	1	INCLUDES ITEMS W/\$
4-1\$	0845041904	GROMMET	2	
5	B3137000803	FIELD ASSY., EXCITER	1	
6	0016008060	HEX. SOCKET HEAD CAP SCREW	4	
7	0042508000	WASHER, LOCK	4	
8	B3153000513	END BRACKET	1	
9	0017108035	HEX. HEAD BOLT	6	
10	B3153400504	PACKING	1	
11	B3153400404	COVER, BEARING	1	
12	0017106016	HEX. HEAD BOLT	3	
13	012010030	HEX. HEAD BOLT.....	12	REPLACES P/N 0012810030
14	B5131300004	COVER, END BRACKET	1	
15	0340406040	HEX. HEAD BOLT	1	
16	020106050	U-NUT.....	1	REPLACES P/N 0600815000
17	952404470	WASHER, FLAT.....	1	REPLACES P/N 0041206000
18	B3131300804	COVER, END BRACKET	1	
19	0401450050	WASHER, FLAT.....	4	REPLACES P/N 0041205000
20	0029205012	HEX. HEAD BOLT	4	
21	Y0605000401	RUBBER SUSPENSION	2	
22	0030012000	HEX. NUT	2	
22A	0040012000	WASHER, LOCK	2	

CONTROL BOX ASSY.

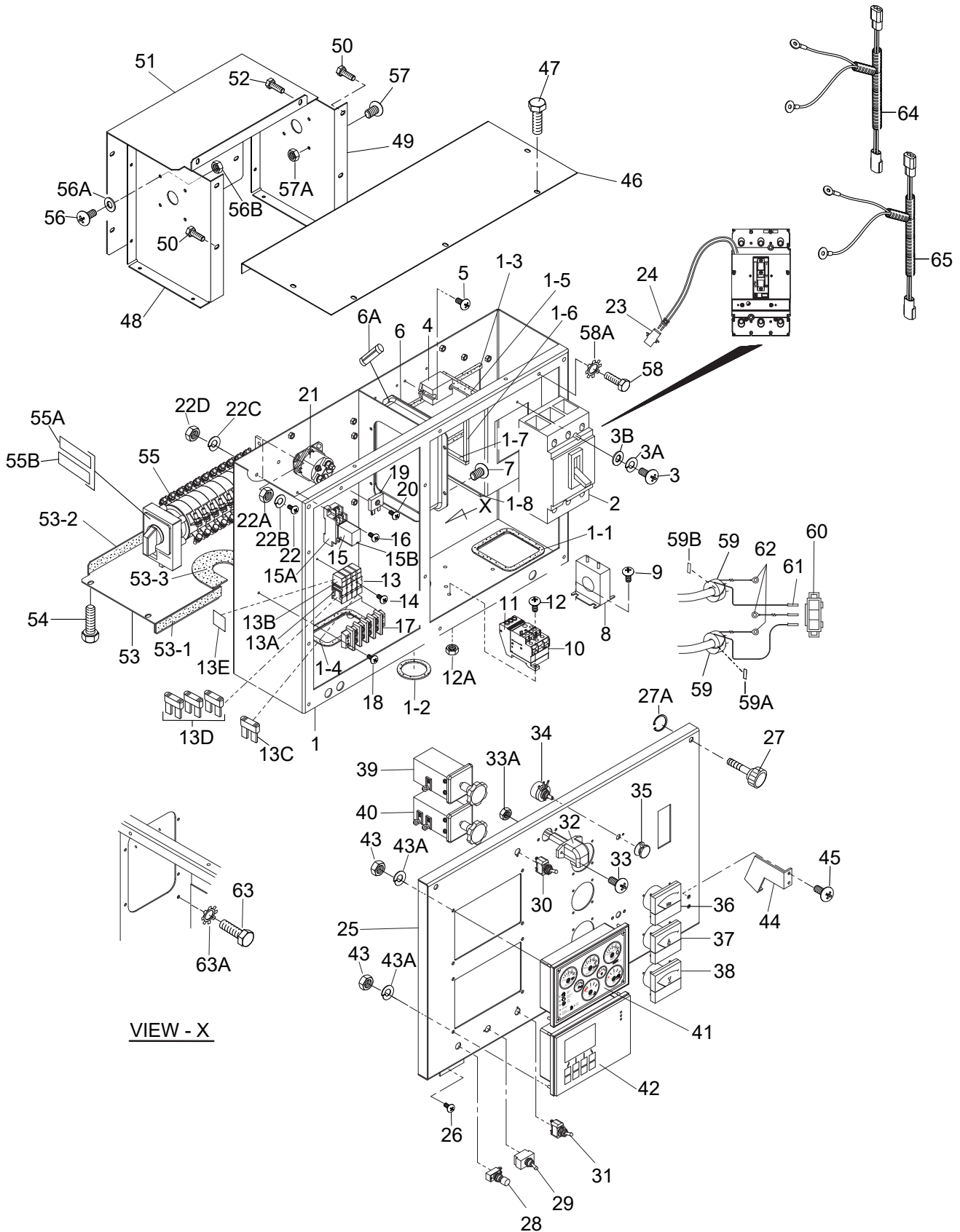

CONTROL BOX ASSY.

<u>NO.</u>	<u>PART NO.</u>	<u>PART NAME</u>	<u>QTY.</u>	<u>REMARKS</u>
1	M2214000502	CONTROL BOX	1	S/N 7307365 AND BELOW
1	M2214000512	CONTROL BOX	1	S/N 7307366 AND ABOVE
1-1	Y0411100350	EDGE TRIM	1	
1-2	Y0411100210	EDGE TRIM	1	
1-3	Y0411100300	EDGE TRIM	2	
1-4	Y0411100320	EDGE TRIM	1	
1-5	Y0411100110	EDGE TRIM	1	
1-6	Y0411100155	EDGE TRIM	1	S/N 7307356 AND ABOVE
1-7	Y0411100060	EDGE TRIM	1	S/N 7307356 AND ABOVE
1-8	Y0411100100	EDGE TRIM	1	S/N 7307356 AND ABOVE
2	Y0601808833	CIRCUIT BREAKER, 3P 200A	1	
3	0021004070	MACHINE SCREW	2	
3A	0040004000	WASHER, LOCK	2	
3B	58042	WASHER, FLAT	2	REPLACES P/N 0041204000
4	0601823863	RELAY UNIT	2	
5	0027104015	MACHINE SCREW	4	
6	Y0601820638	AUTOMATIC VOLTAGE REGULATOR.....	1	INCLUDES ITEMS W/#
6A#	Y0601806683	FUSE, 250V 8A	1	
7	0027105015	MACHINE SCREW	4	
8	Y0601809693	CURRENT TRANSFORMER, 150/5A	3	
9	011808015	MACHINE SCREW	6	REPLACES P/N 0027106015
10	Y0601820839	OVER CURRENT RELAY	1	
11	Y0601820844	OVER CURRENT RELAY BASE	1	
12	0027104020	MACHINE SCREW	2	
12A	OEMAA8	HEX. NUT.....	2	REPLACES P/N 0207004000
13	M2214600004	FUSE BOX ASSY.	1	
13A	Y0601818010	HOUSING	4	
13B	Y0601818011	COVER	4	
13C	0601806643	FUSE, 15A	1	
13D	0601806647	FUSE, 25A	3	
13E	M9501400804	DECAL: FUSE HOLDER	1	
14	Y0027203035	MACHINE SCREW	2	
15	LY2DUS12VDC	RELAY	1	REPLACES P/N 0601827656
15A	PTF08A	BASE.....	1	REPLACES P/N 0601823109
15B	PYCA1	CLIP	2	REPLACES P/N 0601824400
16	0027104015	MACHINE SCREW	2	
17	0601815153	TERMINAL BLOCK	1	S/N 7307365 AND BELOW
17	Y0601816538	TERMINAL BLOCK.....	1	S/N 7307366 AND ABOVE
18	0027104020	MACHINE SCREW	2	
19	0601821370	RECTIFIER	1	REPLACES P/N 0601823240 S/N 7307391 AND BELOW
19	0601821370	RECTIFIER	2	REPLACES P/N 0601823240 S/N 7307392 AND ABOVE
20	0027104020	MACHINE SCREW	1	S/N 7307391 AND BELOW
20	0027104030	MACHINE SCREW	1	S/N 7307392 AND ABOVE
21	Y0602201458	RELAY, STARTER	1	

CONTROL BOX ASSY. (CONT'D.)

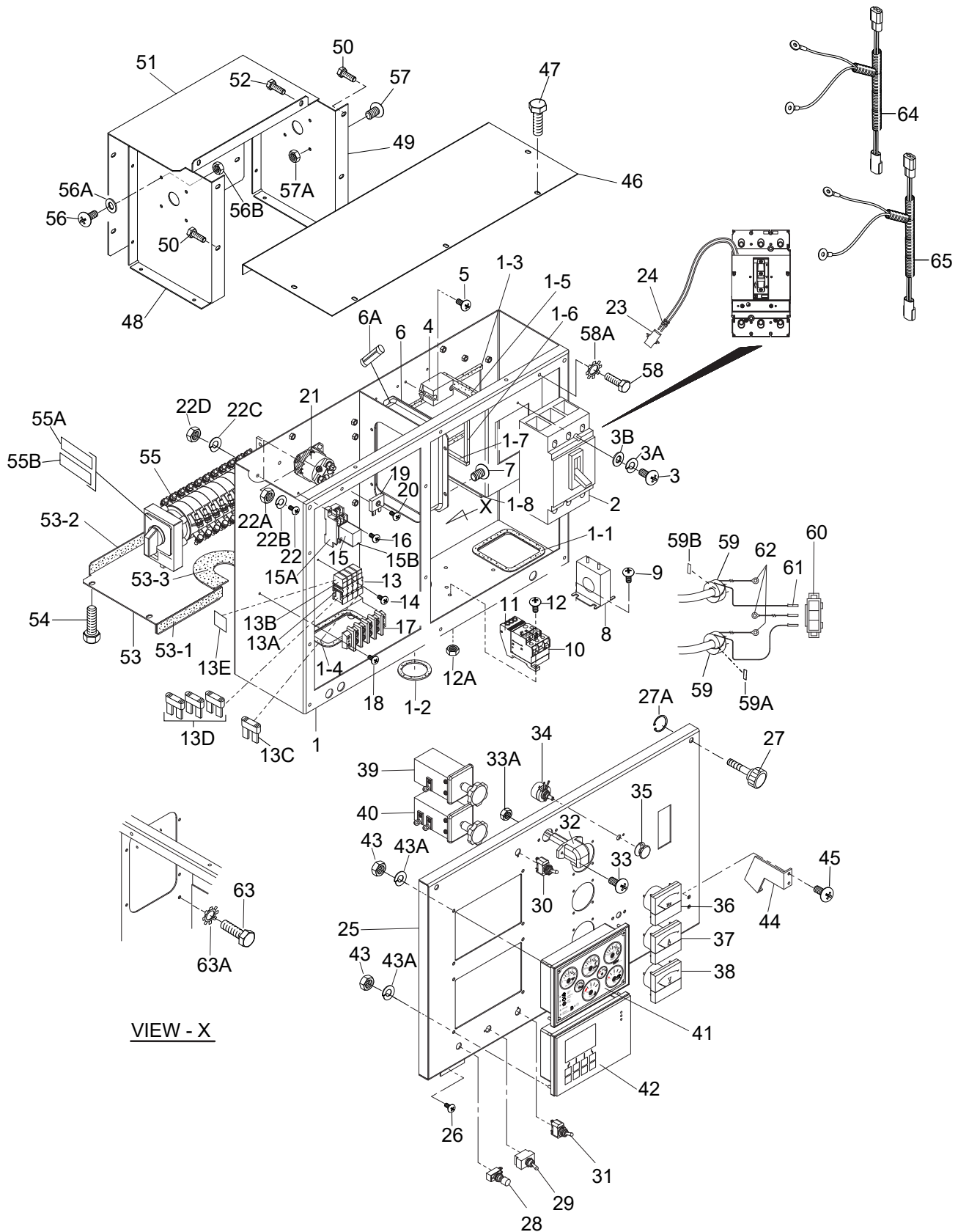

CONTROL BOX ASSY. (CONT'D.)

<u>NO.</u>	<u>PART NO.</u>	<u>PART NAME</u>	<u>QTY.</u>	<u>REMARKS</u>
22	011808015	MACHINE SCREW	2	REPLACES P/N 0027106015
22A	Y0206508000	HEX NUT	2	
22B	0044808000	WASHER, LOCK	2	
22C	Y0206803000	HEX NUT	2	
22D	0043003000	WASHER, LOCK	2	
23	0601812626	PLUG	1	
24	0601812711	PINS	2	
25	M2224000303	CONTROL PANEL	1	
26	0027105010	MACHINE SCREW	4	
27	M9220100004	SET SCREW	2	
27A	Y0080200007	E-SNAP RING	2	
28	0601831205	PUSH BUTTON SWITCH	1	
29	82608	TOGGLE SWITCH	1	REPLACES P/N 0601831340
30	0601830710	PANEL LIGHT SWITCH	1	
31	0601830710	TOGGLE SWITCH	1	
32	Y0601810170	PANEL LIGHT, 12V	1	
33	0027104015	MACHINE SCREW	2	
33A	OEMAA8	SELF-LOCKING NUT	2	REPLACES P/N 0207004000
34	0601840073	RHEOSTAT (VR) 2W 1KΩ	1	
35	0601840100	KNOB	1	REPLACES P/N 0601840121
36	0601807641	FREQUENCY METER, 240V 45~65HZ	1	
37	0601808987	AC AMMETER, 0~150A/300A:5A	1	
38	0601806859	AC VOLTMETER, 0~600V	1	
39	0601801040	CHANGE-OVER SWITCH, AMMETER	1	
40	0601801041	CHANGE-OVER SWITCH, VOLTMETER	1	
41	Y0602120568	GAUGE UNIT ASSY.	1	S/N 7307365 AND BELOW
41	Y0602120903	GAUGE UNIT ASSY.	1	S/N 7307366 AND ABOVE
42	Y0602203043	CONTROLLER, ECU845	1	S/N 7307365 AND BELOW
42	Y0602203077	CONTROLLER, ECU845 UL	1	S/N 7307366 AND ABOVE
43	Y0206707000	HEX. NUT	8	
43A	Y0044807000	WASHER, LOCK	8	
44	M1224100104	STOPPER	1	
45	0027105015	MACHINE SCREW	2	
46	M2213500704	CONTROL BOX COVER	1	
47	0016906015	HEX. HEAD BOLT	4	
48	M2213602704	SWITCH BRACKET	1	
49	M2214600104	SWITCH BRACKET	1	S/N 7307365 AND BELOW
49	M2214600114	SWITCH BRACKET	1	S/N 7307366 ~ 7307381
49	M2213602704	SWITCH BRACKET	1	S/N 7307382 AND ABOVE
50	0016906015	HEX. HEAD BOLT	4	
51	M2213602804	SWITCH COVER	1	
52	0016906015	HEX. HEAD BOLT	6	
53	M2213602904	SWITCH COVER	1	
53-1	0228800165	SEAL RUBBER	1	
53-2	0228800115	SEAL RUBBER	1	
53-3	0317700180	WEATHER STRIP	1	

CONTROL BOX ASSY. (CONT'D.)

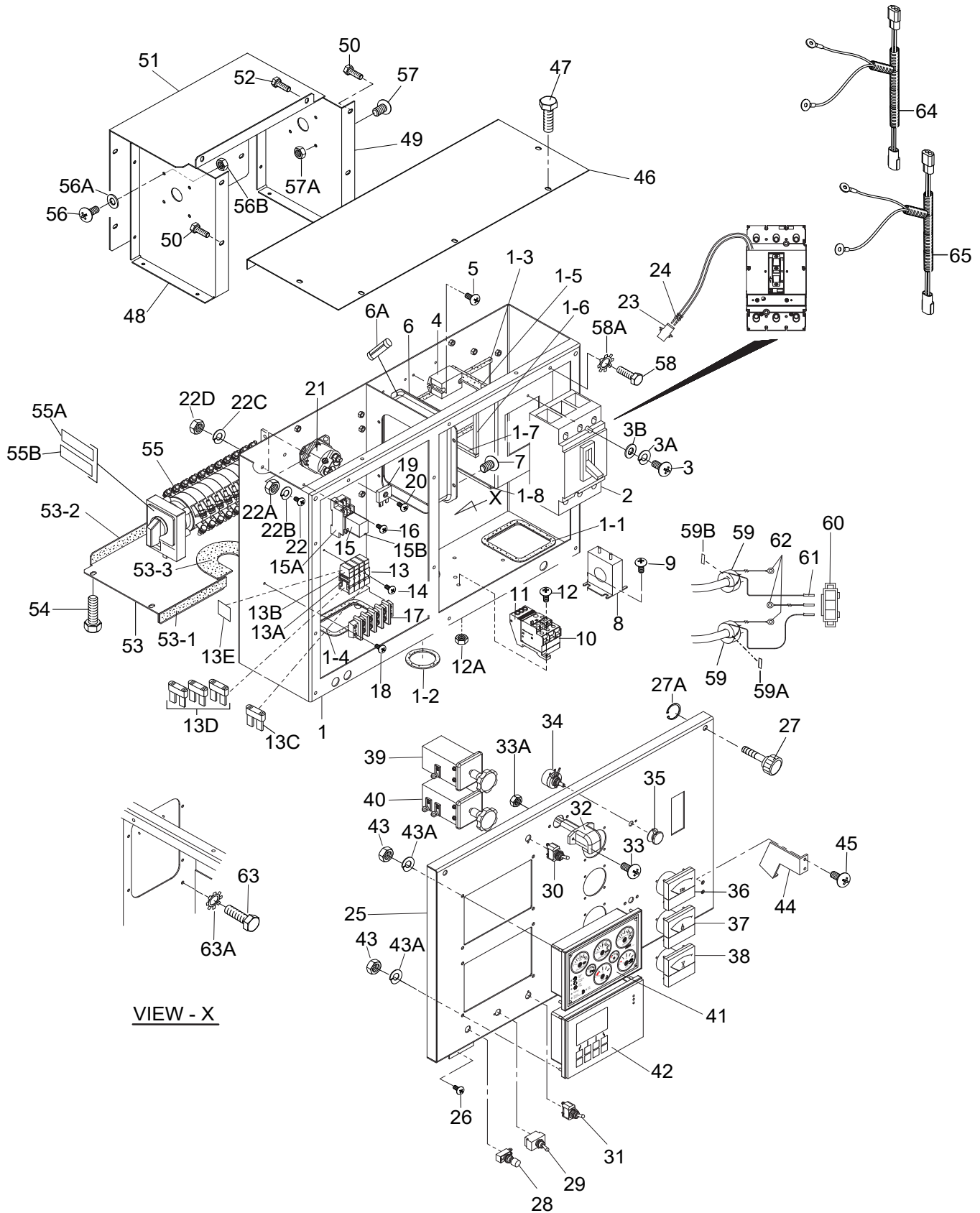

CONTROL BOX ASSY. (CONT'D.)

<u>NO.</u>	<u>PART NO.</u>	<u>PART NAME</u>	<u>QTY.</u>	<u>REMARKS</u>
54	0016906015	HEX. HEAD BOLT	4	
55	M2270100104	SELECTOR SWITCH	1	
55A	M2550001604	DECAL: SELECTOR SWITCH NUMBER ...1	1	M25000160
55B	M2550001704	DECAL: SELECTOR SWITCH NUMBER ...1	1	M25000170
56	0021004035	MACHINE SCREW	4	
56A	58042	WASHER, FLAT	4	REPLACES P/N 0041204000
56B	OEMAA8	HEX. NUT	4	REPLACES P/N 0207004000
57	0027104015	MACHINE SCREW	4	
57A	OEMAA8	HEX. NUT	4	REPLACES P/N 0207004000
58	0016906015	HEX. HEAD BOLT	12	
58A	0040506000	TOOTHED WASHER	1	
59	Y0601872910	CURRENT TRANSFORMER	2	
59A	M9521001604	DECAL: CT4	1	
59B	M9521001704	DECAL: CT5	1	
60	Y0601813924	PLUG	1	
61	0601812711	PINS	3	
62	Y0601815587	ROUND TERMINAL	3	
63	Y0016906020	HEX. HEAD BOLT	2	
63A	0040506000	TOOTHED WASHER	2	
64	M2247700624	WIRE HARNESS, GENERATOR	1	
65	M2358200202	WIRE HARNESS, ENGINE	1	S/N 7307391 AND BELOW
65	M2358200212	WIRE HARNESS, ENGINE	1	S/N 7307392 AND ABOVE

ENGINE AND RADIATOR ASSY.

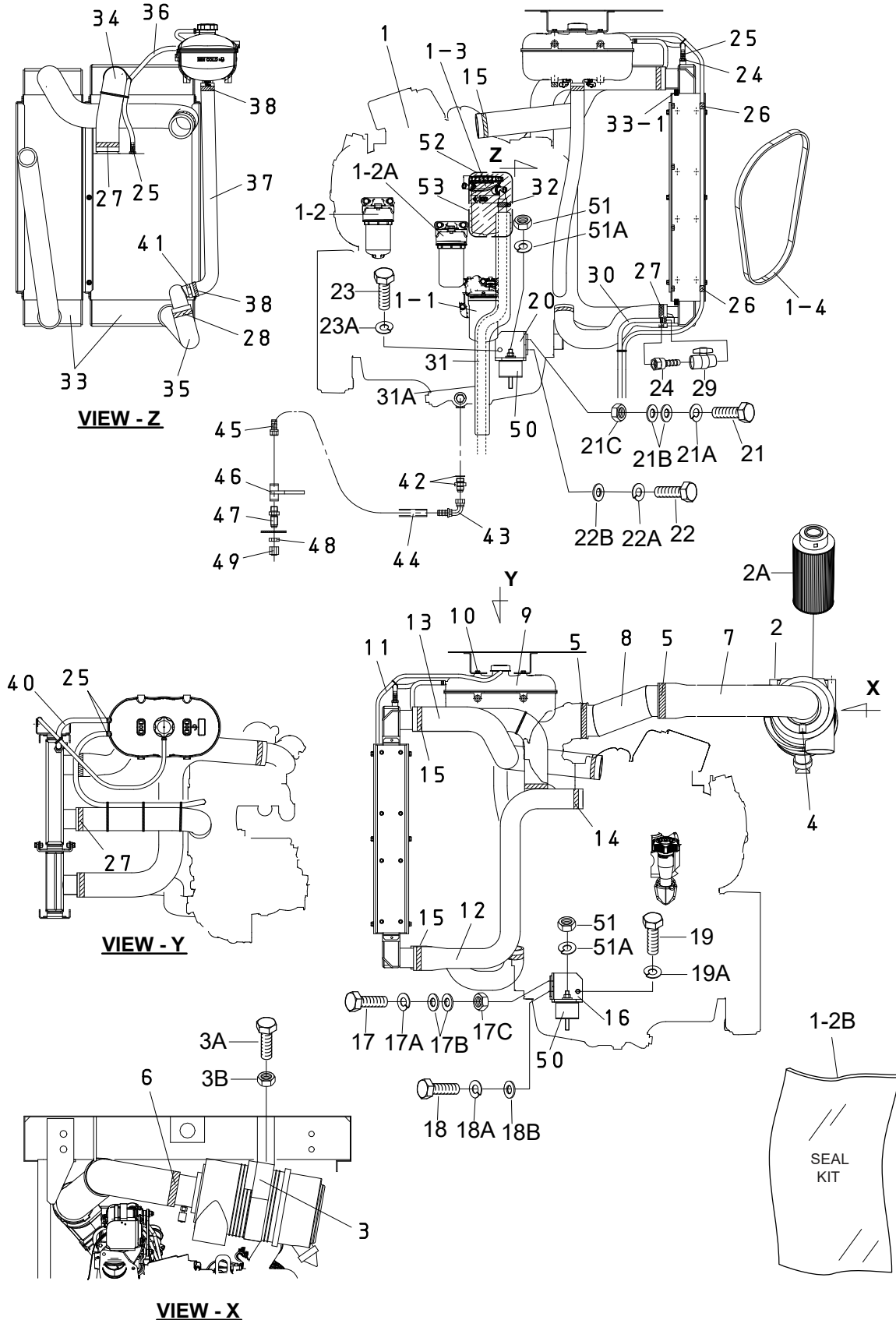

ENGINE AND RADIATOR ASSY.

<u>NO.</u>	<u>PART NO.</u>	<u>PART NAME</u>	<u>QTY.</u>	<u>REMARKS</u>
1	4045HFG04	ENGINE, JOHN DEERE	1	
1-1	RE504836	CARTRIDGE, OIL FILTER	2	REPLACES P/N Y0602041298
1-2	RE551507	FUEL FILTER ELEMENT, (PRIMARY).....	1	REPLACES P/N Y0602042800
1-2A	RE551508	FUEL FILTER ELEMENT, (SECONDARY)..	1	REPLACES P/N Y0602042802
1-2B	RE562696	SEAL KIT (FUEL FILTER)	1	REPLACES P/N Y0602042603
1-3	RE540710	BLOWBY FILTER ELEMENT	1	REPLACES P/N Y0602044230
1-4	R533597	FAN BELT	1	REPLACES P/N Y0602015205
2	FPG082527	AIR CLEANER	1	REPLACES P/N Y0602046582
				INCLUDES ITEMS W/#
2A#	0602046365	ELEMENT	1	REPLACES P/N P828889
3	P777732	AIR CLEANER BAND	1	REPLACES P/N 0602040554
3A	011208030	HEX. HEAD BOLT	2	REPLACES P/N 0016908030
3B	Y0207008000	SELF LOCK NUT	2	
4	0602040651	AIR CLEANER INDICATOR	1	
5	0605515197	HOSE BAND	2	
6	0605515225	HOSE BAND	1	
7	M2374100003	AIR CLEANER HOSE	1	
8	M2374000004	AIR CLEANER PIPE	1	
9	DZ102141	SURGE TANK	1	REPLACES P/N Y0602010221
10	011008020	HEX. HEAD BOLT	2	REPLACES P/N 0016908020
11	Y0193602300	OVERFLOW HOSE	1	
12	M2311500303	INTER COOLER HOSE, LOWER	1	
13	M2311500203	INTER COOLER HOSE, UPPER	1	
14	0605515215	HOSE BAND	1	
15	0605515236	HOSE BAND	3	
16	M3304200004	ENGINE FOOT	1	
17	Y0013616050	HEX HEAD BOLT	1	
17A	0040016000	WASHER, LOCK	1	
17B	0041216000	WASHER, FLAT	2	
17C	0030316000	HEX. NUT	1	
18	0013616040	HEX HEAD BOLT	1	
18A	0040016000	WASHER, LOCK	1	
18B	0041216000	WASHER, FLAT	1	
19	Y0013612035	HEX HEAD BOLT	1	
19A	0040012000	WASHER, LOCK	1	
20	M3304200104	ENGINE FOOT	1	
21	Y0013616065	HEX HEAD BOLT	1	
21A	0040016000	WASHER, LOCK	1	
21B	0041216000	WASHER, FLAT	2	
21C	0030016000	HEX. NUT	1	
22	0013616040	HEX HEAD BOLT	1	
22A	0040016000	WASHER, LOCK	1	
22B	0041216000	WASHER, FLAT	1	

ENGINE AND RADIATOR ASSY. (CONT'D.)

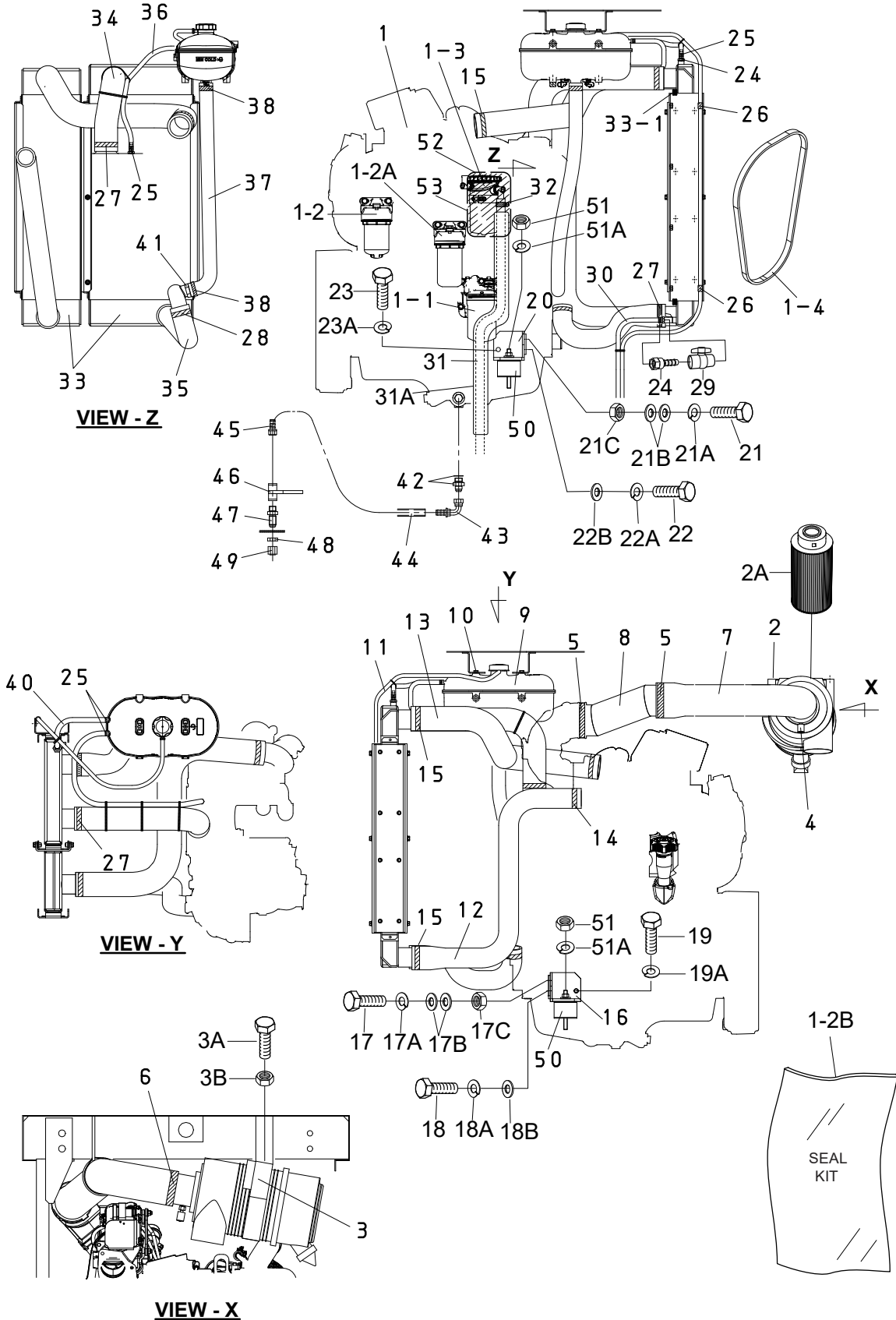

ENGINE AND RADIATOR ASSY. (CONT'D.)

<u>NO.</u>	<u>PART NO.</u>	<u>PART NAME</u>	<u>QTY.</u>	<u>REMARKS</u>
23	Y0013612035	HEX HEAD BOLT	1	
23A	0040012000	WASHER, LOCK	1	
24	Y0605512192	HOSE JOINT	2	
25	0605515189	HOSE BAND	4	
26	0602220911	CLAMP	2	
27	9500202080	HOSE BAND	3	REPLACES P/N 0605515178
28	0605515199	HOSE BAND	1	
29	Y0605511394	MINI BALL VALVE	1	
30	Y0193600900	DRAIN HOSE	1	
31	Y0191600870	BLOWBY HOSE	1	
31A	Y0378700850	AEROFLEX TUBE	1	
32	0605515134	HOSE BAND	1	
33	Y0602012909	RADIATOR AND INTER-COOLER	1	
33-1	M2494102104	ACOUSTIC SHEET	2	S/N 7307116 AND BELOW
33-1	M2494105304	ACOUSTIC SHEET	2	S/N 7307117 AND ABOVE
34	M2311500003	RADIATOR HOSE, UPPER	1	
35	M2311500103	RADIATOR HOSE, LOWER	1	
36	0199900750	VENT HOSE	1	
37	M2311500413	SURGE TANK HOSE	1	
38	0605515149	HOSE BAND	2	
40	0199900300	VENT HOSE	1	
41	AT326597	WATER PUMP JOINT	1	REPLACES Y0602010226
42	0602022563	ADAPTER	1	S/N 7307147 AND BELOW
42	0602022580	ADAPTER	1	S/N 7307148 AND ABOVE
43	0602022561	90 DEGREE ELBOW	1	S/N 7307339 AND BELOW
44	Y0269200370	PUSH-LOCK HOSE	1	S/N 7307339 AND BELOW
44	M2301000414	OIL DRAIN HOSE	1	S/N 7307340 AND ABOVE
45	0603306395	MALE PIPE	1	S/N 7307339 AND BELOW
46	0605511395	BALL VALVE	1	
47	0603306590	MALE BULKHEAD CONNECTOR	1	
48	0603300285	BULKHEAD ROCKNUT	1	
49	0602021070	CAP	1	
50	Y0605000401	RUBBER SUSPENSION	2	
51	0030012000	HEX NUT	2	
51A	0040012000	WASHER, LOCK	2	
52	Y0602044502	BLOWBY FILTER COVER, UPPER.....	1	S/N 7307138 ~ 7307247
52	Y0602044508	BLOWBY FILTER COVER, UPPER.....	1	S/N 7307248 AND ABOVE
53	Y0602044504	BLOWBY FILTER COVER, LOWER.....	1	S/N 7307138 AND ABOVE

OUTPUT TERMINAL ASSY.

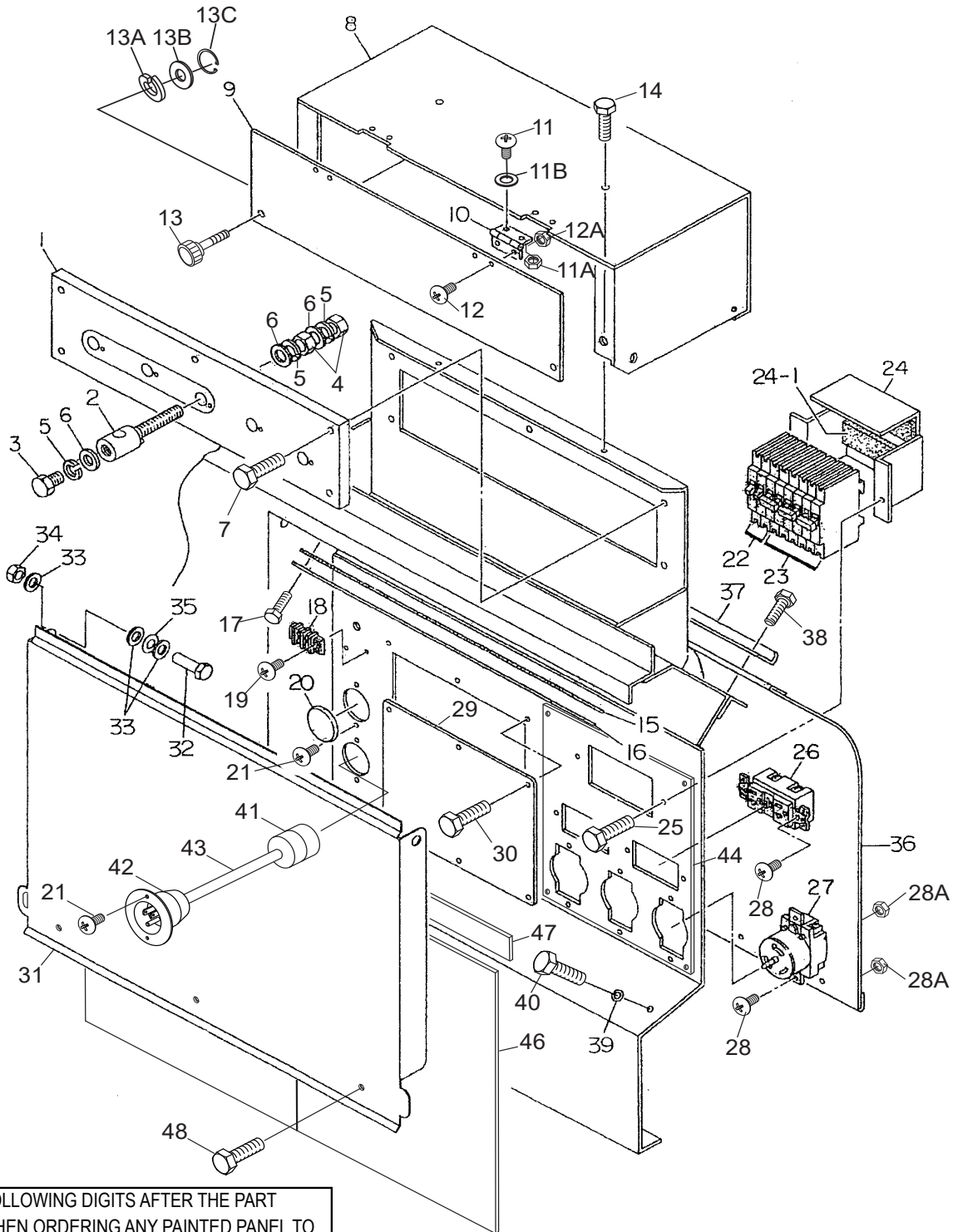

ADD THE FOLLOWING DIGITS AFTER THE PART NUMBER WHEN ORDERING ANY PAINTED PANEL TO INDICATE COLOR OF UNIT:

- | | |
|-----------------|----------------------|
| 1-ORANGE | 5-BLACK |
| 2-WHITE | 6-CATERPILLAR YELLOW |
| 3-SPECTRUM GREY | 7-CATO GOLD |
| 4-SUNBELT GREEN | 8-RED |

THE SERIAL NUMBER MAY BE REQUIRED.

OUTPUT TERMINAL ASSY.

<u>NO.</u>	<u>PART NO.</u>	<u>PART NAME</u>	<u>QTY.</u>	<u>REMARKS</u>
1	M3230700003	TERMINAL PANEL	1	
2	M9220100304	OUTPUT TERMINAL BOLT	5	
3	0801830804	TIE BOLT.....	5	REPLACES P/N M9220100404
4	0039316000	HEX. NUT	10	
5	0040016000	WASHER, LOCK	15	
6	0401450160	WASHER, FLAT	20	REPLACES P/N 0041416000
7	0012108035	HEX. HEAD BOLT	5	REPLACES P/N 0016908035
8	M2237100103	3-PHASE OUTPUT TERMINAL COVER	1	
9	M3236100104	OUTPUT WINDOW	1	
10	0605010040	HINGE	2	
11	0027103010	MACHINE SCREW	4	
11A	0207003000	HEX. NUT.....	4	REPLACES P/N 0030003000
11B	0041203000	WASHER, FLAT	4	
12	0027103010	MACHINE SCREW	4	
12A	0207003000	HEX. NUT.....	4	REPLACES P/N 0030003000
13	M9220100804	SET SCREW	2	
13A	0040006000	WASHER, LOCK	2	
13B	952404470	WASHER, FLAT	2	REPLACES P/N 0041206000
13C	0080200005	E-SNAP RING	2	
14	0016906015	HEX. HEAD BOLT	4	
15	M3236400004	RUBBER, CABLE OUTLET COVER	1	
16	M3236300004	SUPPORTER, CABLE OUTLET COVER	1	
17	011206020	HEX. HEAD BOLT	6	REPLACES P/N 0016906020
18	Y0601816539	TERMINAL BLOCK, 601-GP-02.....	1	REPLACES 0601815194 S/N 7307365 AND BELOW
18	Y0601816539	TERMINAL BLOCK, TB200-02	1	S/N 7307366 ~ 7307375
18	Y0601815870	TERMINAL BLOCK, KT-20-2P	1	S/N 7307376 AND ABOVE
19	0027104015	MACHINE SCREW	2	S/N 7307365 AND BELOW
19	0027104020	MACHINE SCREW	2	S/N 7307366 AND ABOVE
20	0603306775	BLIND PLUG	2	
21	0027104015	MACHINE SCREW	4	
22	0601808803	CIRCUIT BREAKER, 1P 20A	2	
23	0601808804	CIRCUIT BREAKER, 2P 50A	3	
24	M1260700304	BREAKER FITTING COVER	1	
24-1	0222100150	CUSHION RUBBER	1	
25	011206020	HEX. HEAD BOLT	2	REPLACES P/N 0016906020
26	Y0601814034	RECEPTACLE, 125V 20A X 2	2	
27	0601814014	RECEPTACLE, 250V 50A	3	
28	0027104015	MACHINE SCREW	10	
28A	OEMAA8	HEX. NUT.....	10	REPLACES P/N 0207004000
29	M2453400004	COVER	1	
30	0016906015	HEX. HEAD BOLT	6	
31	M2237100003	TERMINAL COVER.....	1	S/N 7307167 AND BELOW
31	M2237100403	TERMINAL COVER.....	1	S/N 7307168 AND ABOVE
32	012212045	HEX. HEAD BOLT	2	REPLACES P/N 0010112045

OUTPUT TERMINAL ASSY. (CONT'D.)

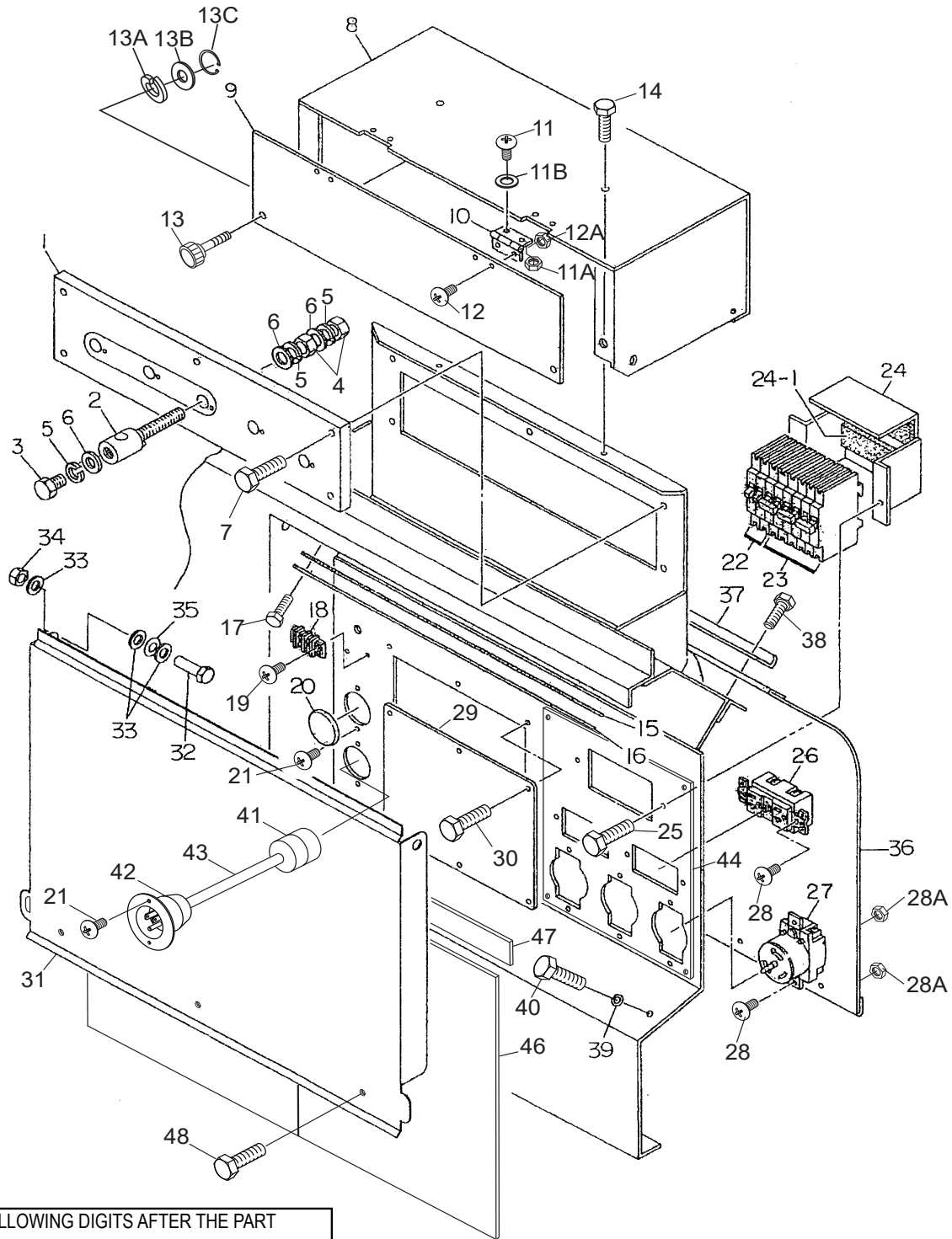

ADD THE FOLLOWING DIGITS AFTER THE PART NUMBER WHEN ORDERING ANY PAINTED PANEL TO INDICATE COLOR OF UNIT:

- | | |
|-----------------|----------------------|
| 1-ORANGE | 5-BLACK |
| 2-WHITE | 6-CATERPILLAR YELLOW |
| 3-SPECTRUM GREY | 7-CATO GOLD |
| 4-SUNBELT GREEN | 8-RED |

THE SERIAL NUMBER MAY BE REQUIRED.

OUTPUT TERMINAL ASSY. (CONT'D.)

<u>NO.</u>	<u>PART NO.</u>	<u>PART NAME</u>	<u>QTY.</u>	<u>REMARKS</u>
33	031112230	WASHER, FLAT	6	REPLACES P/N 0041212000
34	0030012000	HEX. NUT	2	
35	0605050060	CONICAL SPRING WASHER	2	
36	M4236100604	INSULATING COVER	1	
37	M4236400304	SUPPORTER, INSULATING COVER	1	
38	0016906015	HEX. HEAD BOLT	2	
39	0040508000	TOOTHED WASHER	1	
40	0019208025	HEX. HEAD BOLT	1	
41	0601812527	CONNECTOR	1	S/N 7307148 ~ 7307345
42	HBL5278C	INLET FLANGE	1	REPLACES P/N 0601811177 S/N 7307148 ~ 7307345
43	M1358200804	WIRE HARNESS, WATER HEATER.....	1	S/N 7307148 ~ 7307345
43	0601813079	WATER HEATER CABLE.....	1	S/N 7307346 AND ABOVE
44	M3454200904	RECEPTACLE BOARD.....	1	S/N 7307168 AND ABOVE
45	0016906015	HEX. HEAD BOLT	6	S/N 7307168 AND ABOVE
46	M2454700704	RUBBER SHEET	1	S/N 7307168 AND ABOVE
47	M2454700804	RUBBER SHEET HOLDER	1	S/N 7307168 AND ABOVE
48	011206020	HEX. HEAD BOLT	3	REPLACES P/N 0019206020 S/N 7307168 AND ABOVE

BATTERY ASSY.

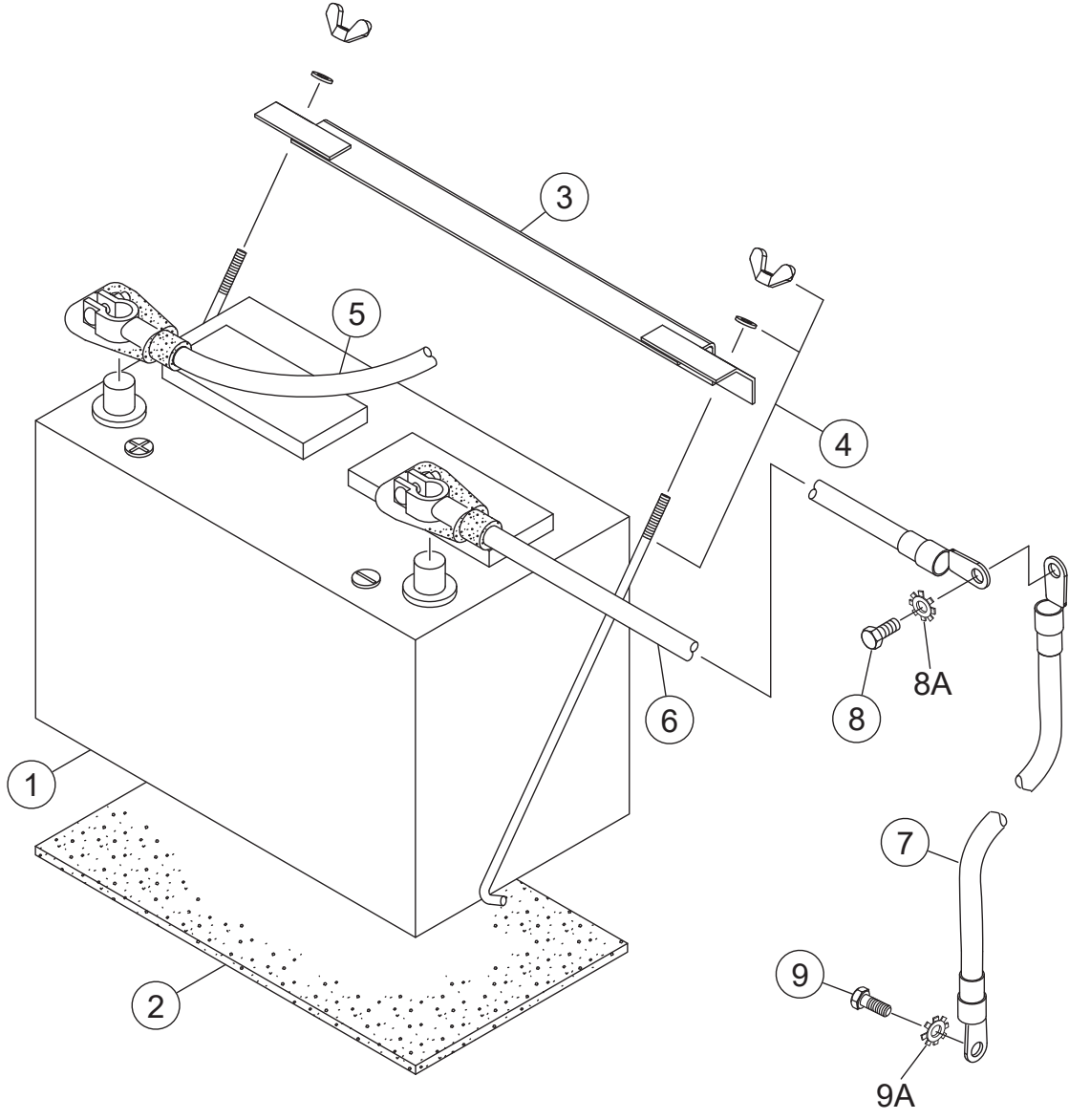

BATTERY ASSY.

<u>NO.</u>	<u>PART NO.</u>	<u>PART NAME</u>	<u>QTY.</u>	<u>REMARKS</u>
1	0602220199	BATTERY	1	
2	M9310500014	BATTERY SHEET	1	
3	M9103000304	BATTERY BAND	1	
4	0602220920	BATTERY BOLT SET	2	
5	M2346900504	BATTERY CABLE	1	
6	M2346900304	BATTERY CABLE	1	
7		CABLE.....	1MAKE LOCALLY
8	0017112025	HEX. HEAD BOLT	1	
8A	0040512000	TOOTHED WASHER	1	
9	011008020	HEX. HEAD BOLT.....	1REPLACES P/N 0016908020
9A	0040508000	TOOTHED WASHER	1	

MUFFLER ASSY.

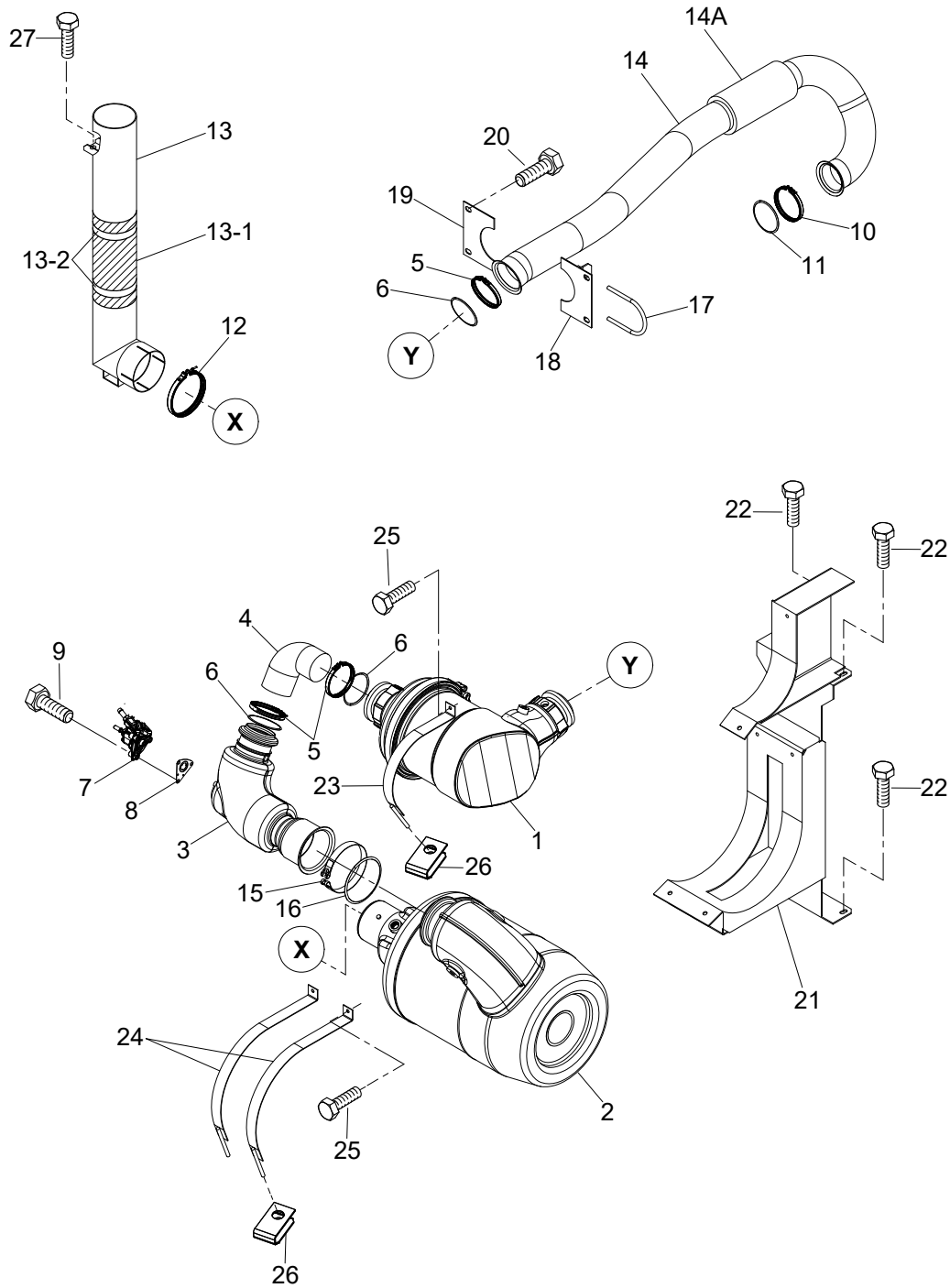

MUFFLER ASSY.

<u>NO.</u>	<u>PART NO.</u>	<u>PART NAME</u>	<u>QTY.</u>	<u>REMARKS</u>
1	Y0602330105	EXHAUST FILTER (DOC).....	1	DZ102172
2	Y0602330303	SCR CATALYST.....	1	RE555854
3	Y0602330417	DECOMPOSITION TUBE.....	1	RE570714
4	RE550428	DECOMPOSITION EXT. TUBE.....	1	REPLACES P/N Y0602330418
5	RE289839	V-BAND CLAMP.....	3	REPLACES P/N Y0602325037
6	R534036	GASKET.....	3	REPLACES P/N Y0602320208
7	RE560468	DEF INJECTOR.....	1	REPLACES P/N Y0602330405
8	RE556879	GASKET.....	1	REPLACES P/N Y0602330406
9	R537624	HEX. HEAD BOLT.....	3	REPLACES P/N Y0602330407
10	RE555336	V-BAND CLAMP.....	1	REPLACES P/N Y0602325031
11	SU34912	GASKET.....	1	REPLACES P/N Y0602320219
12	Y0602325023	PIPE BAND	1	
13	M2334100103	TAIL PIPE	1	
13-1	Y0400002600	INSULATING WRAP	1	
13-2	0605515225	HOSE BAND	2	
14	M2334000803	EXHAUST PIPE	1	
14A	Y0602311148	EXHAUST INSULATING MAT	1	
15	DZ10555	V-BAND CLAMP.....	1	REPLACES P/N Y0602325032
16	R533962	GASKET.....	1	REPLACES P/N Y0602320209
17	0602326060	U BOLT	1	
18	M2331400004	COVER, EXHAUST PIPE	1	
19	M2331400104	COVER, EXHAUST PIPE	1	
20	011008020	HEX. HEAD BOLT.....	4	REPLACES P/N 0016908020
21	M2331400702	BRACKET, DOC AND SCR.....	1	S/N 7307127 AND BELOW
21	M2331400712	BRACKET, DOC AND SCR.....	1	S/N 7307128 AND ABOVE
22	011008020	HEX. HEAD BOLT.....	5	REPLACES P/N 0016908020
23	M2331400804	DOC BAND.....	1	S/N 7307127 AND BELOW
23	M2331400814	DOC BAND.....	1	S/N 7307128 AND ABOVE
24	M2331400904	SCR BAND.....	2	S/N 7307127 AND BELOW
24	M2331400914	SCR BAND.....	2	S/N 7307128 AND ABOVE
25	011008020	HEX. HEAD BOLT.....	3	REPLACES P/N 0016908020
26	020108060	U NUT.....	3	REPLACES P/N 0037908000
27	011008020	HEX. HEAD BOLT.....	1	REPLACES P/N 0016908020

PLUMBING ASSY.

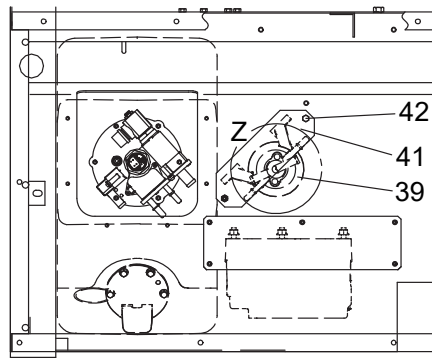

VIEW - Y

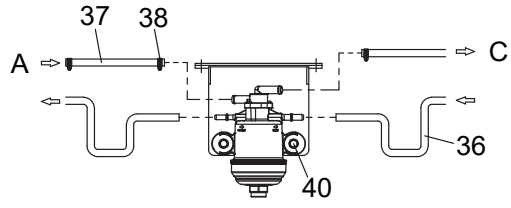

DETAIL - Z

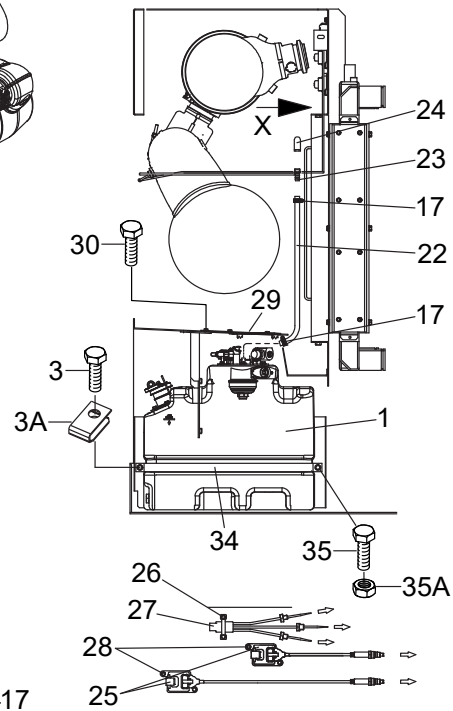
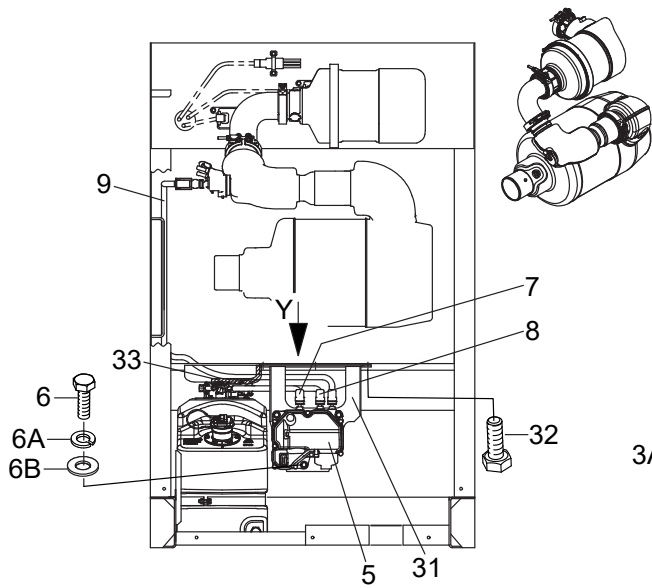

VIEW - X

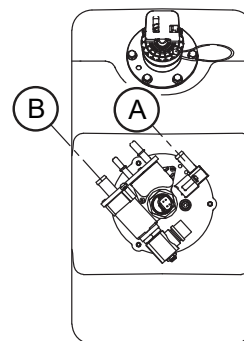
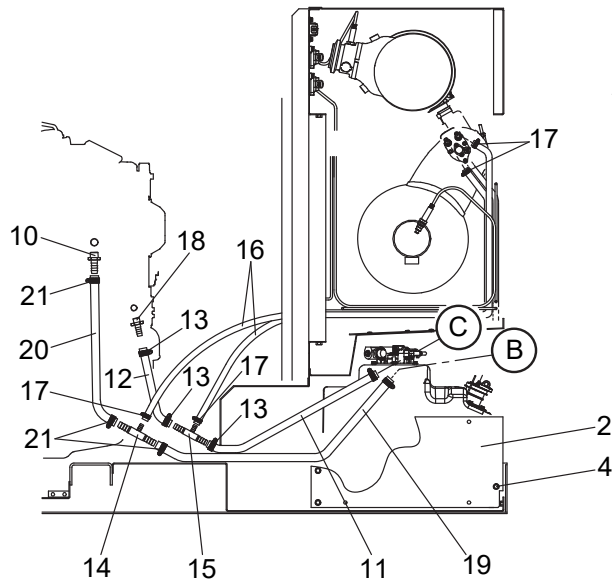

PLUMBING ASSY.

<u>NO.</u>	<u>PART NO.</u>	<u>PART NAME</u>	<u>QTY.</u>	<u>REMARKS</u>
1	DZ103065	DEF TANK.....	1	REPLACES P/N Y0605500073
2	M2331401003	BRACKET, DEF TANK	1	S/N 7307147 AND BELOW
2	M2331401013	BRACKET, DEF TANK	1	S/N 7307148 AND ABOVE
3	011208025	HEX HEAD BOLT.....	1	REPLACES P/N 0016908025 S/N 7307147 AND BELOW
3A	Y0207008000	SELF LOCK NUT	1	S/N 7307147 AND BELOW
3A	Y0207008000	SELF LOCK NUT	2	S/N 7307148 AND ABOVE
4	011208025	HEX HEAD BOLT.....	3	REPLACES P/N 0016908025
5	RE552175	DEF SUPPLY MODULE.....	1	REPLACES P/N Y0602330400 S/N 7307351 AND BELOW
5	0602330516	DEF SUPPLY MODULE.....	1	S/N 7307352 AND ABOVE
6	Y0010108090	HEX HEAD BOLT	3	
6A	0040008000	WASHER, LOCK	3	
6B	0401450080	WASHER, FLAT	3	REPLACES P/N 0041208000
7	RE560902	DEF SUCTION LINE	1	REPLACES P/N Y0602330411 S/N 7307351 AND BELOW
7	0602330514	DEF SUCTION LINE	1	S/N 7307352 AND ABOVE
8	RE560900	DEF BACKFLOW LINE.....	1	REPLACES P/N Y0602330412
9	RE560894	DEF PRESSURE LINE	1	REPLACES P/N Y0602330413
10	AT377287	HOSE BARB	1	REPLACES P/N Y0602022975
11	Y0379701350	COOLANT HOSE.....	1	S/N 7307351 AND BELOW
11	0379700990	COOLANT HOSE.....	1	S/N 7307352 AND ABOVE
12	Y0379700680	COOLANT HOSE	1	
13	Y0605515341	HOSE BAND, 62P08.....	4	S/N 7307375 AND BELOW
13	Y0605515198	HOSE BAND, 5008	4	S/N 7307376 AND ABOVE
14	T317541	BLACK TEE-FITTING W/ORIFICE	1	REPLACES P/N Y0602022976
15	T296925	WHITE TEE-FITTING	1	REPLACES P/N Y0602022977
16	Y0379601870	COOLANT HOSE	2	
17	Y0605515340	HOSE BAND	6	
18	L102179	HOSE JOINT.....	1	REPLACES P/N Y0602022978
19	Y0269301350	COOLANT HOSE	1	
20	Y0269300730	COOLANT HOSE	1	
21	Y0605515341	HOSE BAND, 62P08.....	4	S/N 7307375 AND BELOW
21	Y0605515198	HOSE BAND, 5008	4	S/N 7307376 AND ABOVE
22	0191300700	VENT HOSE	1	
23	H216170	DEF TANK VENT FITTING	1	REPLACES P/N Y0602330402
24	H216169	DEF TANK VENT FILTER	1	REPLACES P/N Y0602330401
25	RE552182	NOX SENSOR	2	REPLACES P/N Y0602330410
26	RE569030	TEMPERATURE SENSOR	1	REPLACES P/N Y0602330206
27	RE542006	TEMPERATURE SENSOR CLAMP	1	REPLACES P/N Y0602330205
28	0016906015	HEX HEAD BOLT	6	
29	M2331401104	DEF TANK COVER	1	
30	Y0016906020	HEX HEAD BOLT	6	

PLUMBING ASSY. (CONT'D.)

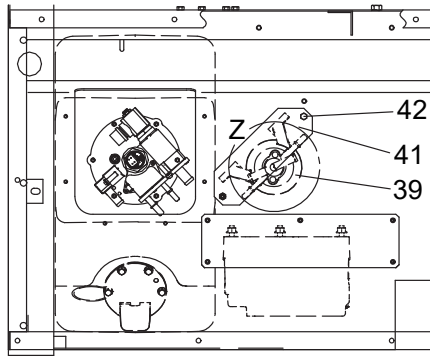

VIEW - Y

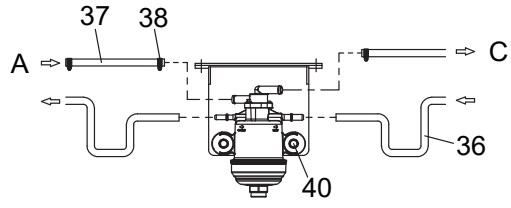

DETAIL - Z

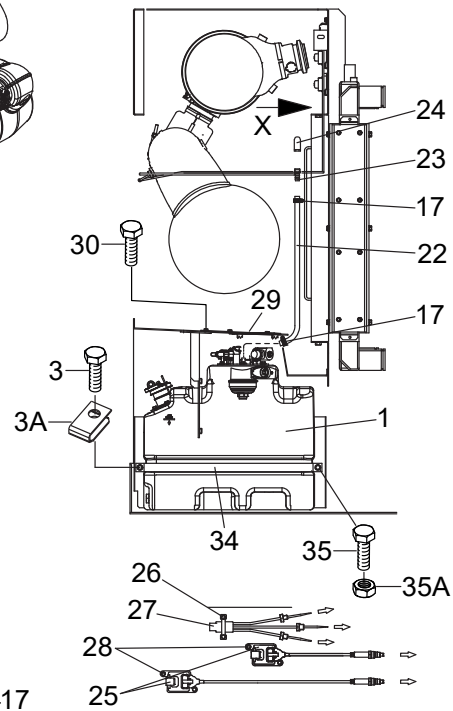
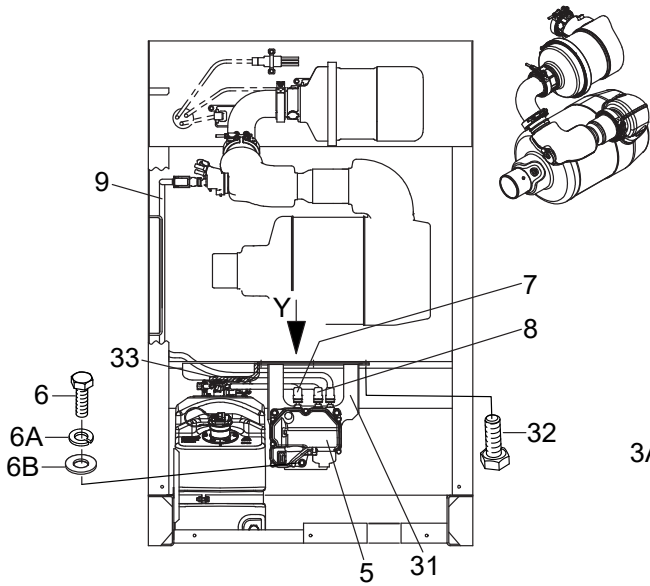

VIEW - X

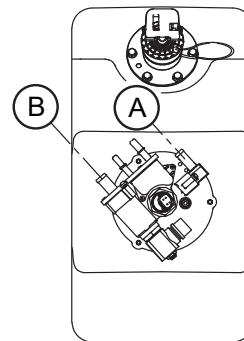
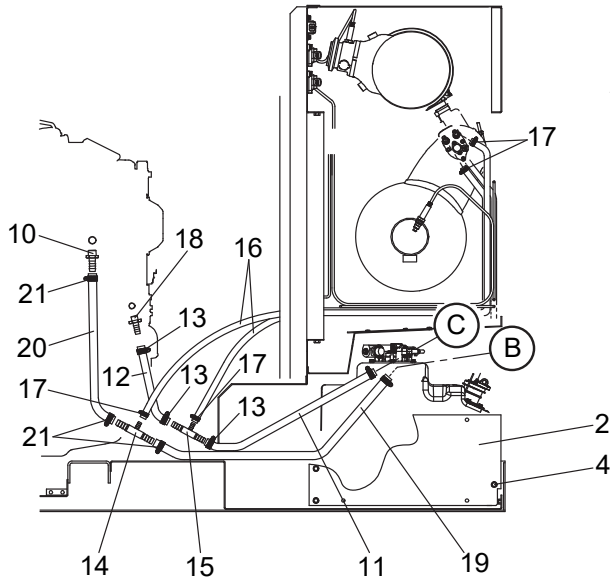

PLUMBING ASSY. (CONT'D.)

<u>NO.</u>	<u>PART NO.</u>	<u>PART NAME</u>	<u>QTY.</u>	<u>REMARKS</u>
31	M2331401204	SUPPLY MODULE BRACKET	1	
32	Y0016906020	HEX HEAD BOLT	5	
33	0317700180	WEATHER STRIP	1	
34	M2331401404	DEF TANK BAND	1	S/N 7307148 AND ABOVE
35	0016908020	HEX HEAD BOLT	1	S/N 7307148 AND ABOVE
35A	Y0207008000	SELF LOCK NUT	1	S/N 7307148 AND ABOVE
36	0602330514	DEF SUCTION JUMPER	1	S/N 7307352 AND ABOVE
37	0379700360	COOLANT HOSE	1	S/N 7307352 AND ABOVE
38	Y0605515341	HOSE BAND	2	S/N 7307352 AND ABOVE
39	DZ118548	DEF FILTER	1	REPLACES P/N Y0602330510 S/N 7307352 AND ABOVE
40	011208030	HEX. HEAD BOLT	2	REPLACES P/N 0016908030 S/N 7307352 AND ABOVE
41	M2331401504	DEF FILTER BRACKET	1	S/N 7307352 AND ABOVE
42	011206020	HEX. HEAD BOLT	2	REPLACES P/N 0016906020 S/N 7307352 AND ABOVE

FUEL TANK ASSY.

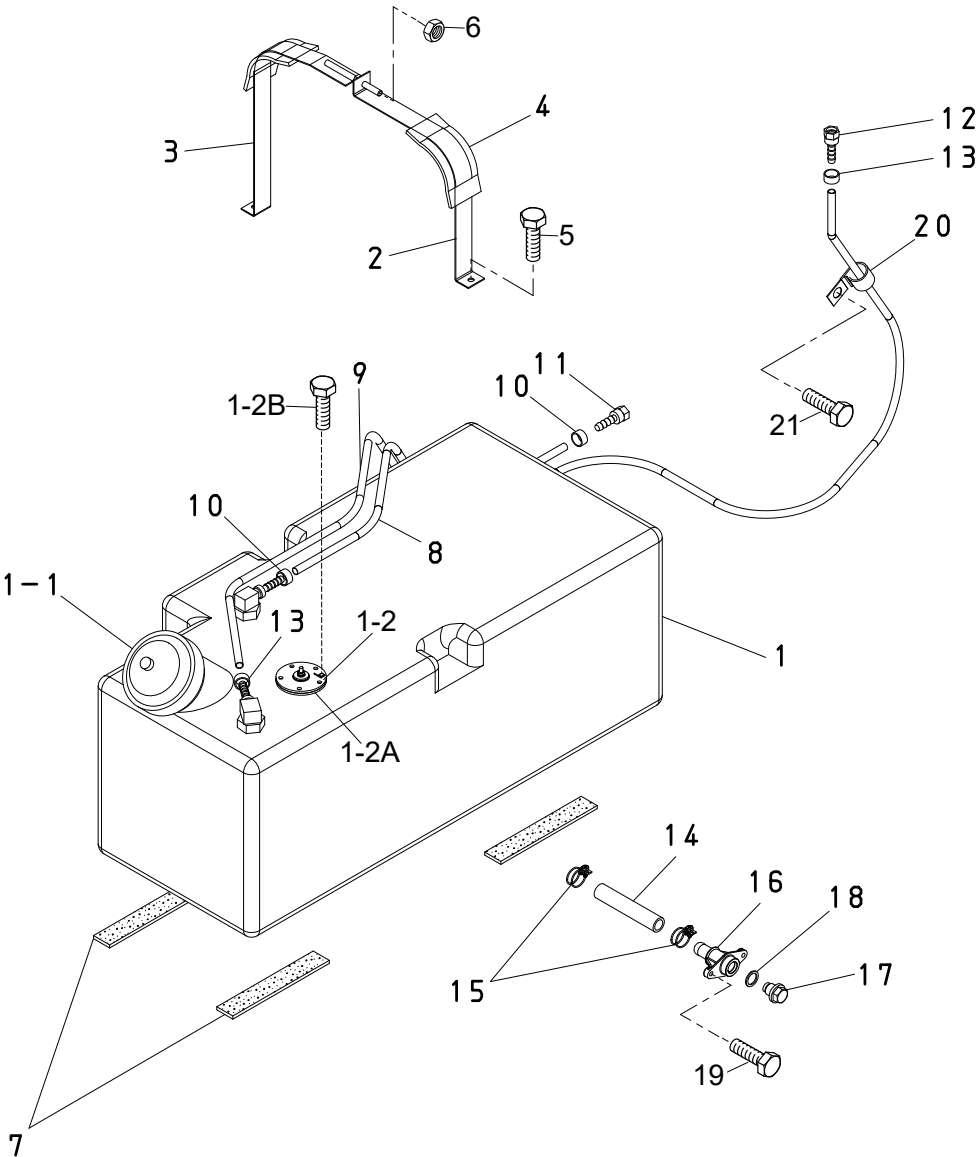

FUEL TANK ASSY.

<u>NO.</u>	<u>PART NO.</u>	<u>PART NAME</u>	<u>QTY.</u>	<u>REMARKS</u>
1	M2364000202	FUEL TANK	1	INCLUDES ITEMS W/#
1-1#	0605505070	FUEL TANK CAP	1	
1-2#	Y0605501058	FUEL SENDER UNIT	1	
1-2A#	Y0605516090	GASKET	1	
1-2B#	Y0605053020	HEX HEAD BOLT	5	
2	M2364200004	TANK BAND	1	
3	M2364200104	TANK BAND	1	
4	M9310500104	SUPPORTER SHEET	2	
5	011008020	HEX. HEAD BOLT	2	REPLACES P/N 0016908020
6	020108060	SELF-LOCKING NUT	2	REPLACES P/N 0207008000
7	0222100180	TANK SHEET	4	
8	0191302000	SUCTION HOSE	1	
9	Y0191102400	RETURN HOSE	1	
10	Y0605515340	HOSE BAND	2	
11	Y0602022558	HOSE JOINT	1	
12	Y0605512530	HOSE JOINT	1	
13	0605515189	HOSE BAND	2	
14	Y0191500180	FUEL DRAIN HOSE	1	
15	0605515198	HOSE BAND	2	
16	1502025103C	OIL DRAIN JOINT	1	REPLACES P/N M9200000003
17	0802011104	DRAIN BOLT	1	REPLACES P/N M9200200004
18	0150000018	O-RING	1	
19	011206020	HEX. HEAD BOLT	2	REPLACES P/N 0016906020
20	M3483600104	COATING CLAMPER	1	
21	0017112025	HEX HEAD BOLT	1	

ENCLOSURE ASSY.

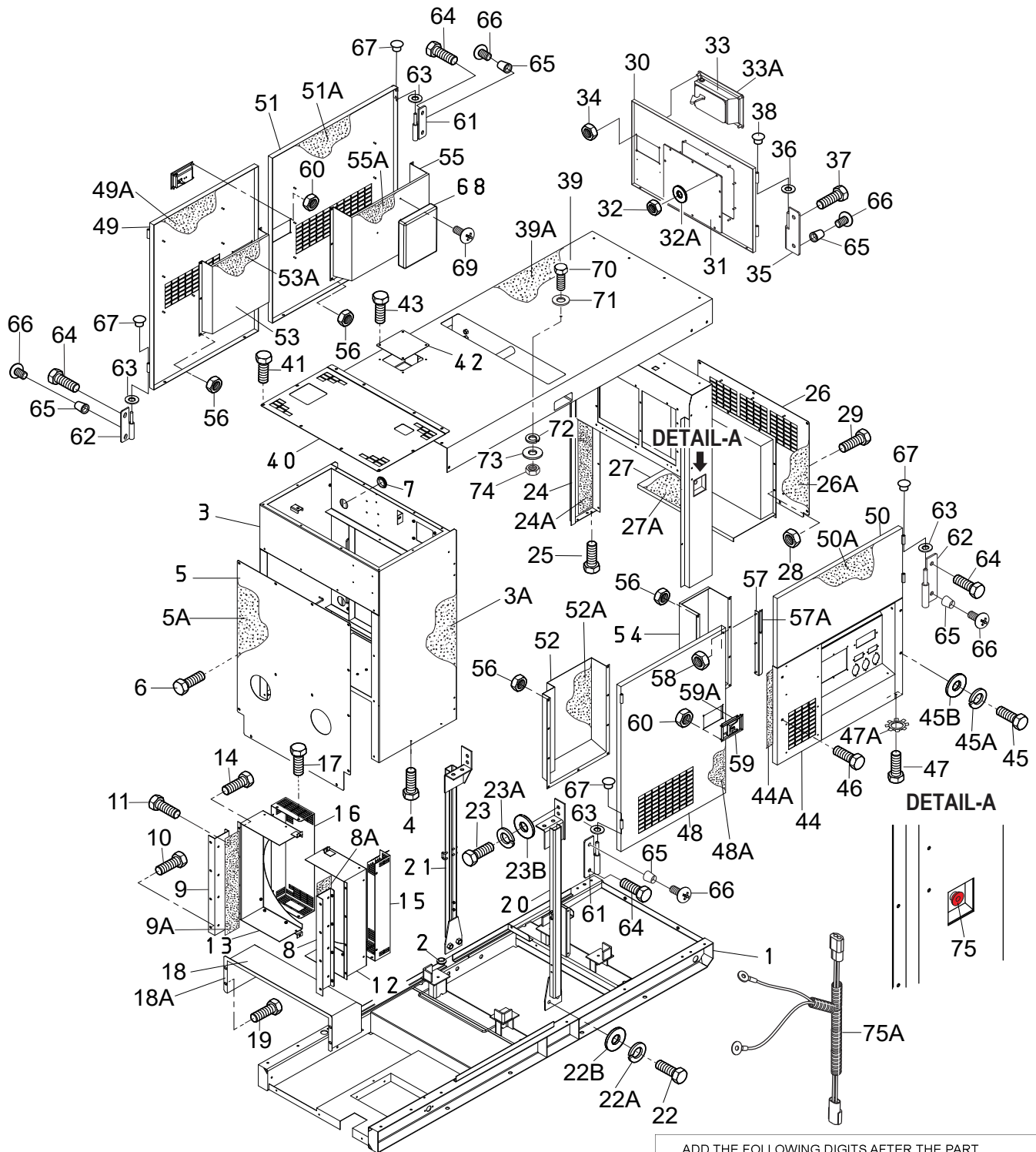

ADD THE FOLLOWING DIGITS AFTER THE PART NUMBER WHEN ORDERING ANY PAINTED PANEL TO INDICATE COLOR OF UNIT:

- | | |
|-----------------|----------------------|
| 1-ORANGE | 5-BLACK |
| 2-WHITE | 6-CATERPILLAR YELLOW |
| 3-SPECTRUM GREY | 7-CATO GOLD |
| 4-SUNBELT GREEN | 8-RED |

THE SERIAL NUMBER MAY BE REQUIRED.

ENCLOSURE ASSY.

<u>NO.</u>	<u>PART NO.</u>	<u>PART NAME</u>	<u>QTY.</u>	<u>REMARKS</u>
1	M2414000402	BASE	1	
2	Y0601850276	GROMMET	1	
3	M2424000302	FRONT FRAME	1	S/N 7307345 AND BELOW
3	M2424000312	FRONT FRAME	1	S/N 7307346 AND ABOVE
3A	M2494102303	ACOUSTIC SHEET	1	
4	011008020	HEX. HEAD BOLT	6	REPLACES P/N 0016908020
5	M2424100504	COVER, FRONT FRAME	1	
5A	M2494101704	ACOUSTIC SHEET	1	
6	0019208020	HEX. HEAD BOLT	15	
7	0601851736	GROMMET	2	
8	M2311200404	RADIATOR BRACKET	1	
8A	M2494409204	ACOUSTIC SHEET	2	
9	M2311200504	RADIATOR BRACKET	1	
9A	M2494409204	ACOUSTIC SHEET	2	
10	011008020	HEX. HEAD BOLT	8	REPLACES P/N 0016908020
11	011008020	HEX. HEAD BOLT	16	REPLACES P/N 0016908020
12	M2311301203	FAN SHROUD	1	
13	M2311301303	FAN SHROUD	1	
14	011008020	HEX. HEAD BOLT	10	REPLACES P/N 0016908020
15	M2311300603	FAN GUARD	1	
16	M2311300703	FAN GUARD	1	
17	011008020	HEX. HEAD BOLT	11	REPLACES P/N 0016908020
18	M2424200303	INNER COVER, FRONT FRAME	1	
18A	Y0411100220	EDGE TRIM	1	
19	011008020	HEX HEAD BOLT	4	REPLACES P/N 0016908020
20	M2434000003	HANGER	1	S/N 7307167 AND BELOW
20	M2434000503	HANGER	1	S/N 7307168 AND ABOVE
21	M2434000103	HANGER	1	
22	Y0013620040	HEX. HEAD BOLT	4	
22A	030220510	WASHER, LOCK	4	REPLACES P/N 0040020000
22B	0041220000	WASHER, FLAT	4	
23	Y0012316035	HEX HEAD BOLT	8	
23A	0040016000	WASHER, LOCK	8	
23B	0041216000	WASHER, FLAT	8	
24	M2444000302	REAR FRAME	1	S/N 7307345 AND BELOW
24	M2444000312	REAR FRAME	1	S/N 7307346 AND ABOVE
24A	M2494301704	ACOUSTIC SHEET	1	S/N 7307345 AND BELOW
24A	M2494301714	ACOUSTIC SHEET	1	S/N 7307346 AND ABOVE
25	011008020	HEX. HEAD BOLT	4	REPLACES P/N 0016908020
26	M2444100004	REAR COVER	1	
26A	M2494300104	ACOUSTIC SHEET	1	
27	M2444300003	DUCT, REAR COVER	1	
27A	M2494300204	ACOUSTIC SHEET	1	
28	0176060030	SELF LOCKING NUT	10	REPLACES P/N 0207006000
29	0019208020	HEX. HEAD BOLT	9	
30	M2444200013	REAR DOOR	1	

ENCLOSURE ASSY. (CONT'D.)

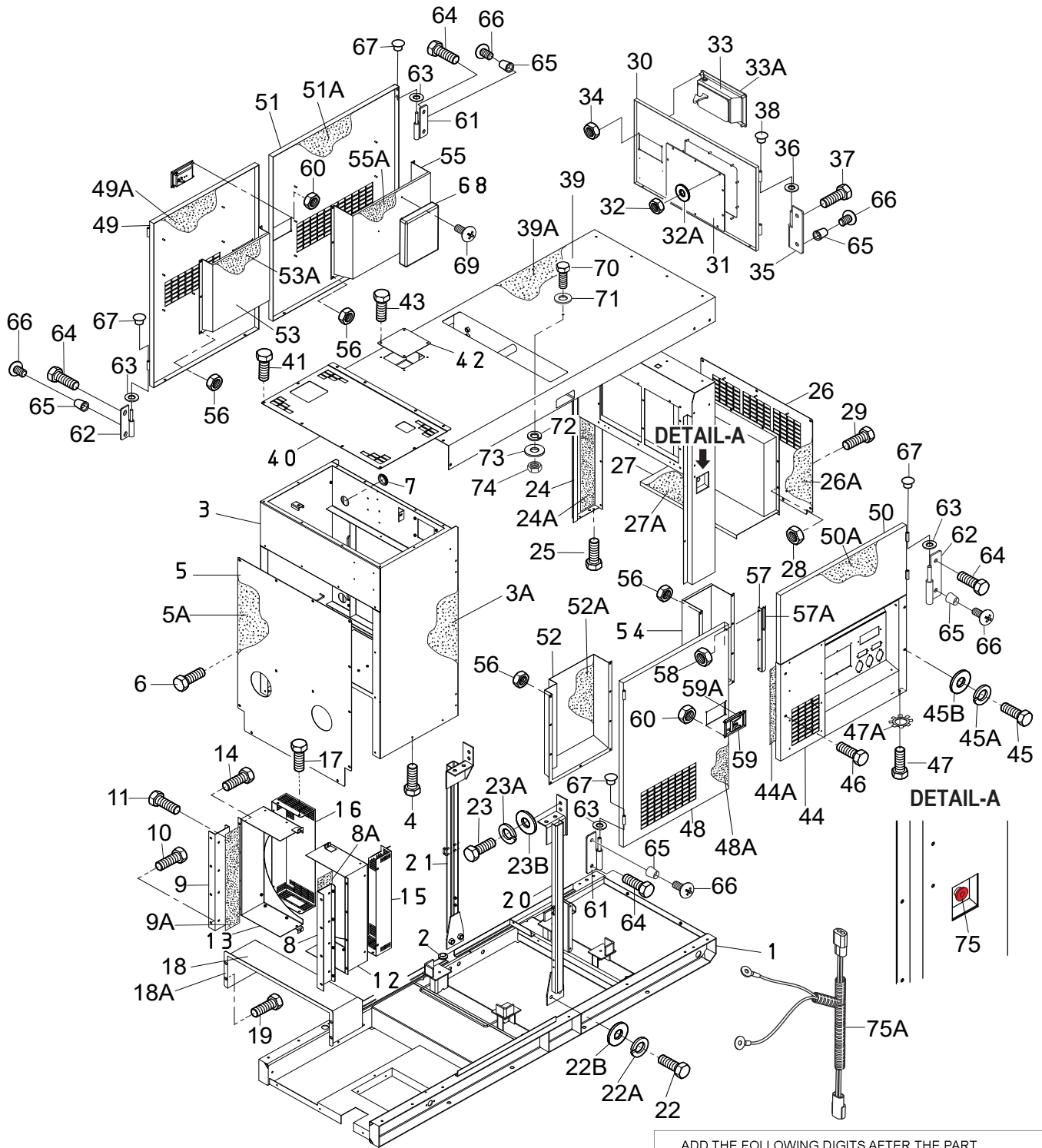

ADD THE FOLLOWING DIGITS AFTER THE PART NUMBER WHEN ORDERING ANY PAINTED PANEL TO INDICATE COLOR OF UNIT:

- | | |
|-----------------|----------------------|
| 1-ORANGE | 5-BLACK |
| 2-WHITE | 6-CATERPILLAR YELLOW |
| 3-SPECTRUM GREY | 7-CATO GOLD |
| 4-SUNBELT GREEN | 8-RED |

THE SERIAL NUMBER MAY BE REQUIRED.

ENCLOSURE ASSY. (CONT'D.)

<u>NO.</u>	<u>PART NO.</u>	<u>PART NAME</u>	<u>QTY.</u>	<u>REMARKS</u>
31	M4443600004	WINDOW PLATE	1	
32	020106050	LOCK NUT	8	REPLACES P/N 0037906000
32A	952404470	WASHER, FLAT	8	REPLACES P/N 0041206000
33	Y0605012309	DOOR HANDLE ASSY.	1	
33A	C9312500004	SEAL RUBBER	1	
34	0176060030	HEX. NUT	4	REPLACES P/N 0207006000
35	M9110100204	HINGE	2	
36	M9116100004	WASHER	2	
37	0019208020	HEX. HEAD BOLT	3	
38	0845031504	BLIND PLUG	2	REPLACES P/N M9310000004
39	M2464000202	ROOF PANEL	1	
39A	M2494502203	ACOUSTIC SHEET	1	
40	M2424200404	OVER COVER, FRONT FRAME	1	
41	0019208020	HEX. HEAD BOLT	24	
42	M2464400004	COVER	1	
43	0019208020	HEX. HEAD BOLT	4	
44	M2454200302	SPLASHER PANEL.....	1	S/N 7307167 AND BELOW
44	M2454200602	SPLASHER PANEL.....	1	S/N 7307168 ~ 7307375
44	M2454201102	SPLASHER PANEL.....	1	S/N 7307376 AND ABOVE
44A	M2494400204	ACOUSTIC SHEET	1	
45	0019108055	HEX. HEAD BOLT	2	
45A	0042308000	WASHER, LOCK	2	
45B	0401450080	WASHER, FLAT	2	REPLACES P/N 0042408000
46	0019208020	HEX. HEAD BOLT	2	
47	011008020	HEX. HEAD BOLT	3	REPLACES P/N 0016908020
47A	0040508000	TOOTHED WASHER	1	
48	M2454000013	SIDE DOOR	1	
48A	M2494400004	ACOUSTIC SHEET	1	
49	M2454000113	SIDE DOOR	1	
49A	M2494400104	ACOUSTIC SHEET	1	
50	M24540002032	SIDE DOOR	1	REPLACES P/N M2454000203
50A	M2494400304	ACOUSTIC SHEET	1	
51	M2454001303	SIDE DOOR	1	
51A	M2494400404	ACOUSTIC SHEET	1	
52	M2454300404	DUCT	1	
52A	M2494403304	ACOUSTIC SHEET	1	
53	M2454300304	DUCT	1	
53A	M2494408904	ACOUSTIC SHEET	1	
54	M2454300104	DUCT	1	
55	M2454301104	DUCT	1	
55A	M2494409304	ACOUSTIC SHEET	1	
56	0176060030	SELF-LOCKING NUT.....	31	REPLACES P/N 0207006000
57	M2454700004	DOOR SUPPORTER	1	
57A	0229200440	RUBBER SEAL	1	
58	0176060030	SELF-LOCKING NUT.....	4	REPLACES P/N 0207006000

ENCLOSURE ASSY. (CONT'D.)

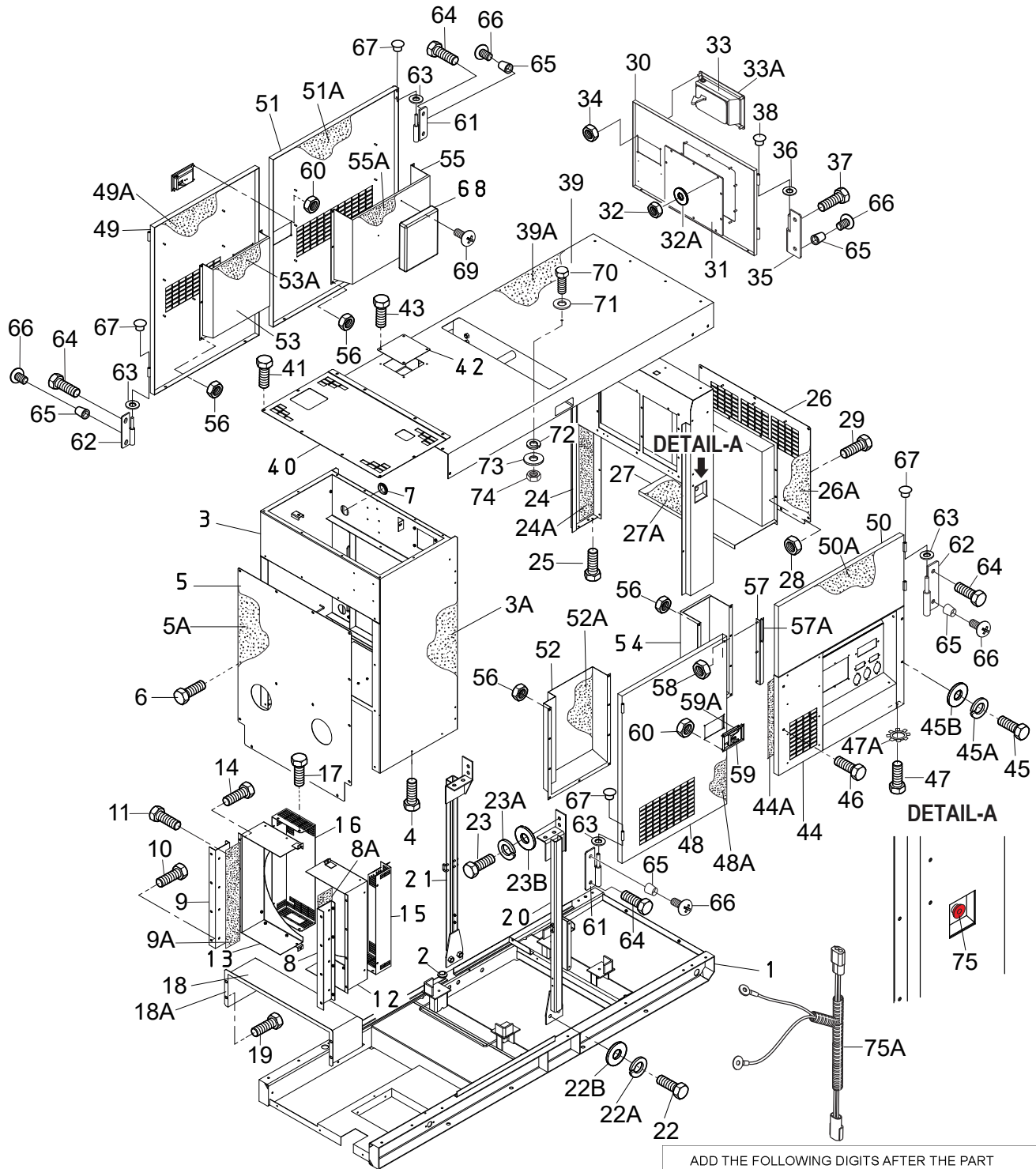

ADD THE FOLLOWING DIGITS AFTER THE PART NUMBER WHEN ORDERING ANY PAINTED PANEL TO INDICATE COLOR OF UNIT:

- | | |
|-----------------|----------------------|
| 1-ORANGE | 5-BLACK |
| 2-WHITE | 6-CATERPILLAR YELLOW |
| 3-SPECTRUM GREY | 7-CATO GOLD |
| 4-SUNBELT GREEN | 8-RED |

THE SERIAL NUMBER MAY BE REQUIRED.

ENCLOSURE ASSY. (CONT'D.)

<u>NO.</u>	<u>PART NO.</u>	<u>PART NAME</u>	<u>QTY.</u>	<u>REMARKS</u>
59	0605012309	DOOR HANDLE ASSY.	3	
59A	C9312500004	SEAL RUBBER	3	
60	0176060030	HEX. NUT.....	12	REPLACES P/N 0207006000
61	M9110100204	HINGE	4	
62	M9110100304	HINGE	4	
63	M9116100004	WASHER	8	
64	0019208020	HEX. HEAD BOLT	9	
65	0601850097	DOOR STOPPER	8	
66	0027208025	MACHINE SCREW	8	
67	0845031504	BLIND PLUG.....	8	REPLACES P/N M9310000004
68	0600800320	MANUAL PAK	1	
69	0021806015	MACHINE SCREW	4	
70	0019112030	HEX. HEAD BOLT.....	1	S/N 7307346 AND ABOVE
71	Y0605050040	SEALING WASHER.....	1	S/N 7307346 AND ABOVE
72	0042312000	WASHER, LOCK.....	1	S/N 7307346 AND ABOVE
73	0042412000	WASHER, FLAT.....	1	S/N 7307346 AND ABOVE
74	0030012000	HEX. NUT.....	1	S/N 7307346 AND ABOVE
75	0601831927	EMERGENCY STOP BUTTON.....	1	S/N 7307346 AND ABOVE
75A	M2358201304	E-STOP WIRE HARNESS.....	1	S/N 7307346 ~ 7307391

RUBBER SEALS ASSY.

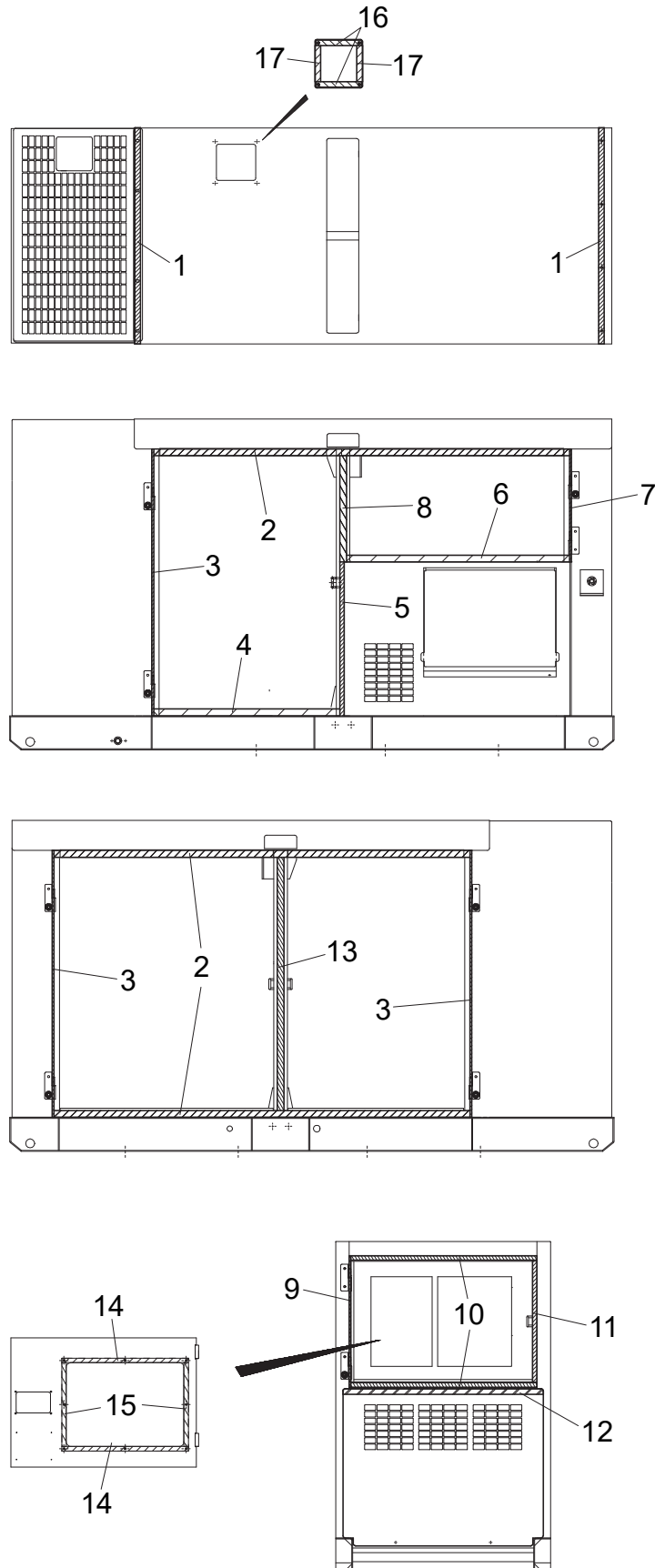

RUBBER SEALS ASSY.

<u>NO.</u>	<u>PART NO.</u>	<u>PART NAME</u>	<u>QTY.</u>	<u>REMARKS</u>
1	0229200950	RUBBER SEAL	2	
2	Y0228901840	RUBBER SEAL	3	
3	Y0229401180	RUBBER SEAL	3	
4	0228900820	RUBBER SEAL	1	
5	Y0228800680	RUBBER SEAL	1	
6	Y0228900985	RUBBER SEAL	1	
7	Y0229400500	RUBBER SEAL	1	
8	0228900470	RUBBER SEAL	1	
9	0228800580	RUBBER SEAL	1	
10	Y0228800820	RUBBER SEAL	2	
11	0228800540	RUBBER SEAL	1	
12	0229200880	RUBBER SEAL	1	
13	0228901120	RUBBER SEAL	1	
14	0228100560	RUBBER SEAL	2	
15	0228100370	RUBBER SEAL	2	
16	0229200210	RUBBER SEAL	2	
17	Y0229200160	RUBBER SEAL	2	

BATTERY CHARGER ASSY.

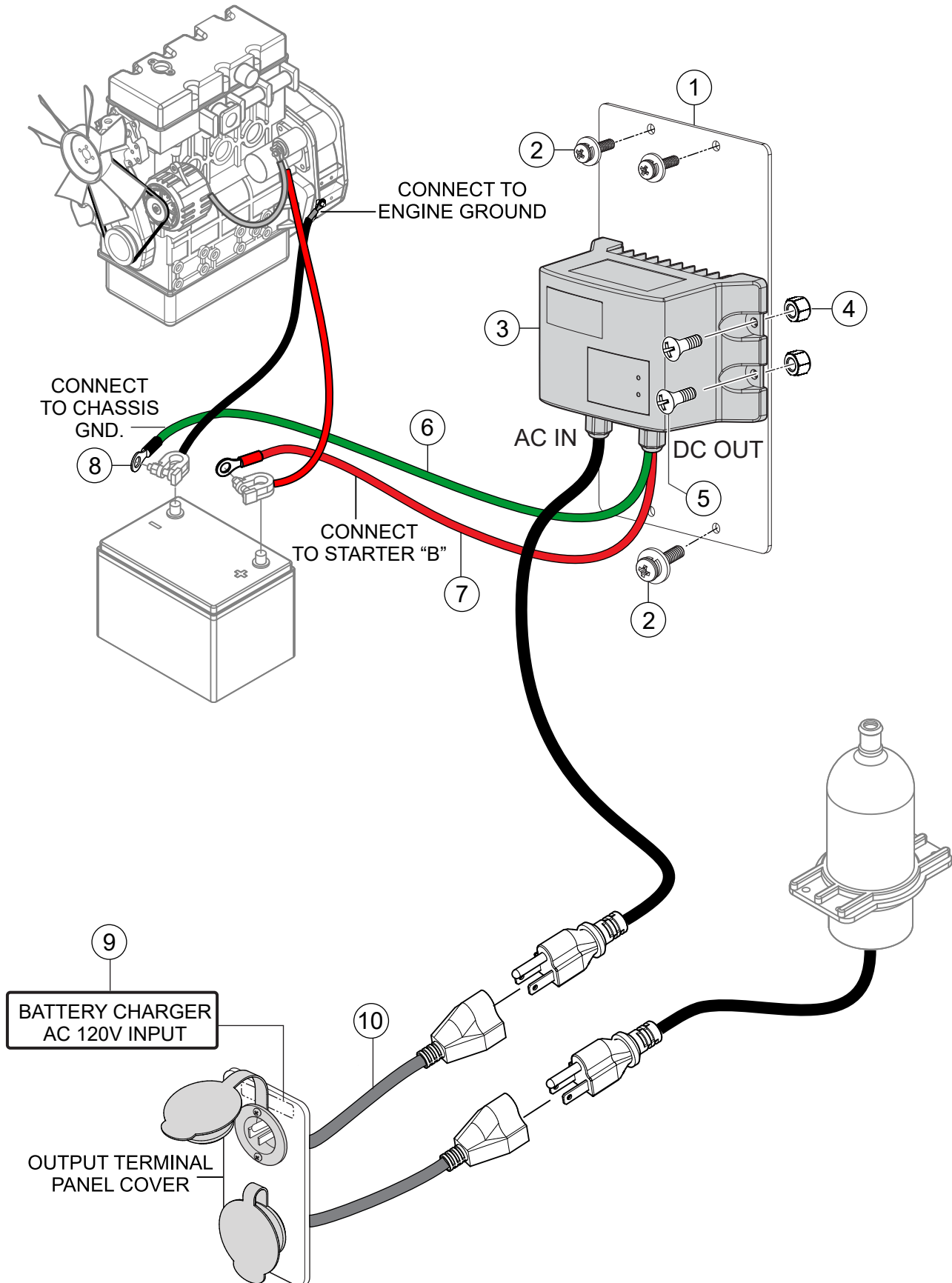

BATTERY CHARGER ASSY.

<u>NO.</u>	<u>PART NO.</u>	<u>PART NAME</u>	<u>QTY.</u>	<u>REMARKS</u>
1	EE62021	MOUNTING PLATE, BATTERY CHARGER	1	
2		M4 X 12MM PAN HD. SCREW W/FLAT WASHER..	4.....	OBTAIN LOCALLY
3	EE62075	BATT. CHARGER, MICROGENIUS LE 6A 12V	1	
4		NUT, HEX. 10-32.....	4.....	OBTAIN LOCALLY
5		SCREW, FLAT HEAD, 1-32 X 1/2".....	4.....	OBTAIN LOCALLY
6		WIRE, 16 AWG, GREEN.....	9 FT.....	OBTAIN LOCALLY
7		WIRE, 16 AWG, RED.....	9 FT.....	OBTAIN LOCALLY
8		1/2" RING TERMINAL, 14-16 AWG.....	2.....	OBTAIN LOCALLY
9	M1940011014Q	DECAL, BATTERY CHARGER, 120V INPUT	1	
10	EE62076	INLET RECPT. & CORD, NEMA 5-15P, 15A 125V	1	

WATER HEATING ELEMENT ASSY. (OPTION)

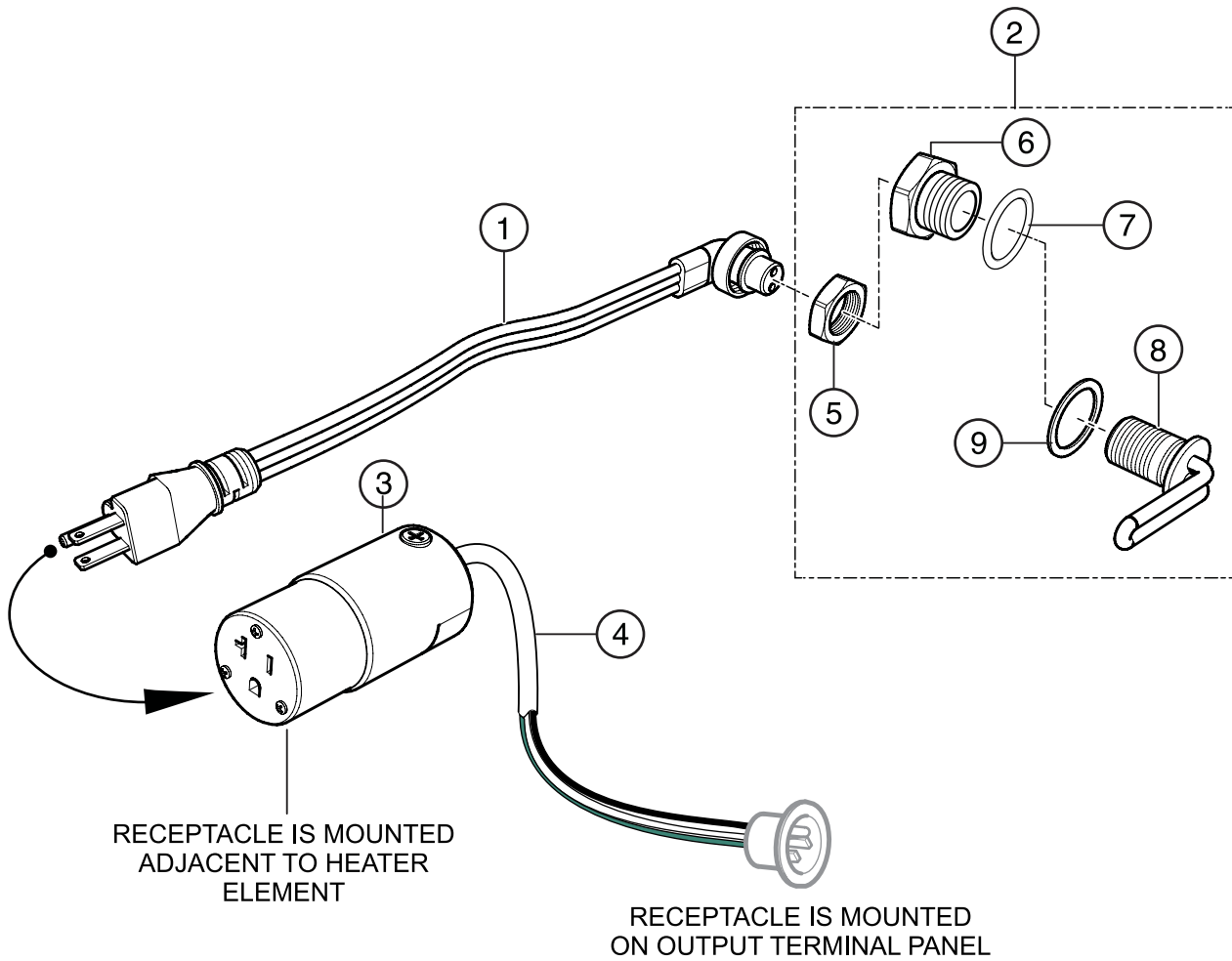

WATER HEATING ELEMENT ASSY. (OPTION)

<u>NO.</u>	<u>PART NO.</u>	<u>PART NAME</u>	<u>QTY.</u>	<u>REMARKS</u>
1	AR50411	CORD ASSY., 110 VOLTS	1	
2	EE54798	KIT, 110 VOLT, COOLANT HEATER.....	1.....	INCLUDES ITEMS W/@
3	HBL5369C	CONNECTOR, 20 AMP., 125V	1	
4	EE56557	CORD, CAROL 3/C 14 AWG	10.....	1 PC - 1 FT
5@		NUT CLAMPING	1	
6@		ADAPTER	1	
7@		O-RING	1	
8@		HEATER ELEMENT, 1000 WATT	1	
9@		GASKET	1	

NAMEPLATE AND DECALS ASSY.

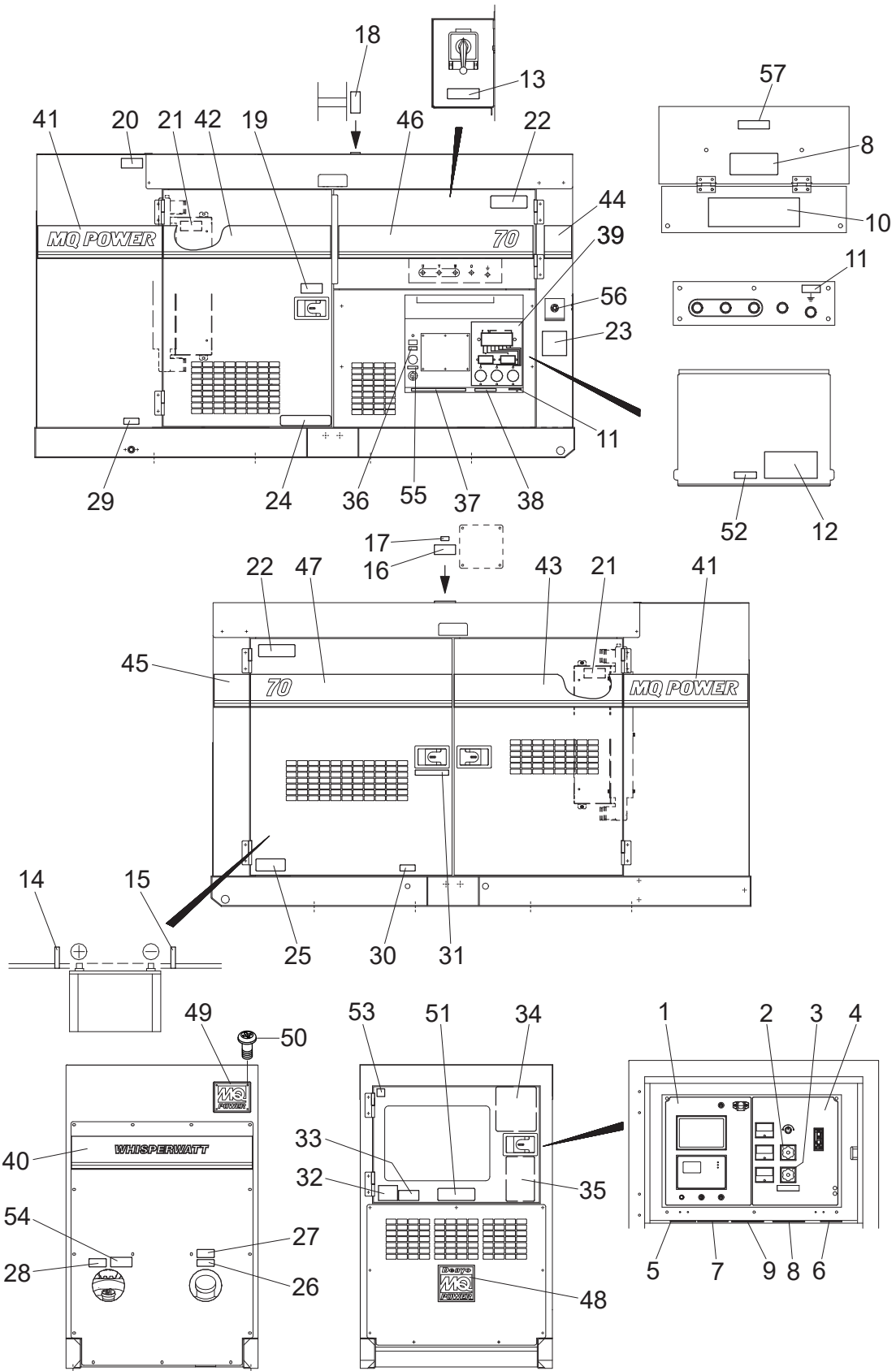

NAMEPLATE AND DECALS ASSY.

<u>NO.</u>	<u>PART NO.</u>	<u>PART NAME</u>	<u>QTY.</u>	<u>REMARKS</u>
1	M2551000603	DECAL: ENGINE OPERATION	1	M25100060
2	M9520000104	DECAL: AMMETER CHANGE-OVER SW.....	1	M92000010
3	M9520000204	DECAL: VOLTMETER CHANGE-OVER SW.....	1	M92000020
4	M2551000403	DECAL: GENERATOR CONTROL	1	M25100040
5	M9501300004	DECAL: CAUTION BATTERY CABLES.....	1	M90130000
6	M9520100704	DECAL: WARNING ARC FLASH.....	1	M92010070
7	M9520100304	DECAL: GENERAL CAUTIONS.....	1	M92010030
8	M9520100004	DECAL: WARNING ELECTRICAL SHOCK.....	2	M92010000
9	M9520200404	DECAL: O. C. R. RESET	1	M92020040
10	M9520200003	DECAL: CONNECTION OF OUTPUT CABLE	1	M92020000
11	M9520000004	DECAL: GROUNDING	2	M92000000
12	M9520100404	DECAL: DANGER HIGH VOLTAGE	1	M92010040
13	M9520100204	DECAL: CAUTION CHANGE-OVER SW.....	1	M92010020A
14	M9500300104	DECAL: +	1	M90030010
15	M9500300004	DECAL: -	1	M90030000
16	M9503100004	DECAL: WARNING RADIATOR CAP	1	M90310000
17	M9500100004	DECAL: WATER.....	1	M90010000
18	M1550001504	DECAL: CAUTION LIFTING CAPACITY.....	1	M15000150
19	M9510100004	DECAL: CAUTION HIGH TEMP.....	1	M91010000
20	M9503200004	DECAL: WARNING EXHAUST GAS	1	M90320000
21	M9503000004	DECAL: WARNING ROTATING PART.....	2	M90300000
22	M9520100603	DECAL: WARNING AUTO START	2	M92010060
23	M2550000304	DECAL: NOTE LOAD SHARING.....	1	M25000030A
24	M9503000103	DECAL: DAILY CHECK WATER AND OIL	1	M90300010
25	M9510100403	DECAL: WARNING BATTERY CONNECT.....	1	M91010040A
26	M9501500004	DECAL: DIESEL FUEL	1	M90150000
27	M9504500004	DECAL: REFILL DEF AS WELL.....	1	M90450000
28	M9501500104	DECAL: DIESEL EXHAUST FLUID	1	M90150010
29	M9500500104	DECAL: FUEL DRAIN	1	M90050010
30	M9500000004	DECAL: OIL DRAIN	1	M90000000
31	M9510000104	DECAL: DOCUMENT BOX LOCATED	1	M91000010
32	M9503200104	DECAL: DANGER EX. GAS (INDOOR)	1	M90320010
33	M9504200004	DECAL: WARNING START FIRES.....	1	M90420000
34	M2551000703	DECAL: EX FILTER CLEAN PROCEDURES	1	M25100070
35	M2551000303	OPERATING PROCEDURES	1	M25100030
				S/N 7307345 AND BELOW
35	M2551000803	OPERATING PROCEDURES	1	M25100080
				S/N 7307346 AND ABOVE
36	M9520000504	DECAL: START CONTACT	1	M92000050
37	M9520100503	DECAL: WARNING.....	1	M92010050
38	M1550000204	DECAL: NOTE RECEPTACLE	1	M15000020
39	M1550000703	DECAL: AUXILIARY OUTPUT.....	1	M15000070
				S/N 7307167 AND BELOW
39	M3551002003	DECAL: AUXILIARY OUTPUT.....	1	M35100200
				S/N 7307168 ~ 7307345
39	M3551002803	DECAL: AUXILIARY OUTPUT.....	1	M35100200
				S/N 7307346 AND ABOVE

NAMEPLATE AND DECALS ASSY. (CONT'D.)

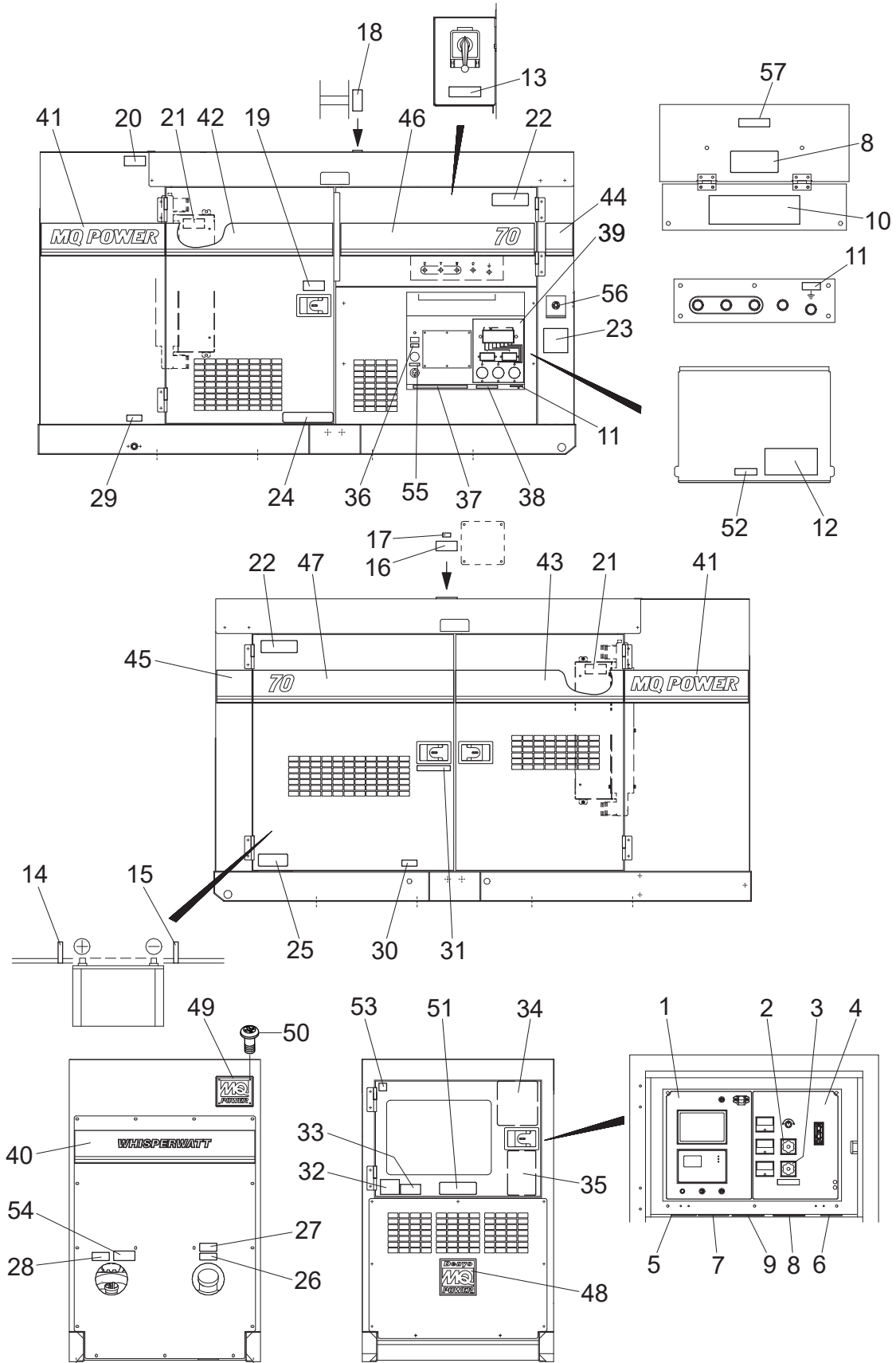

NAMEPLATE AND DECALS ASSY. (CONT'D.)

<u>NO.</u>	<u>PART NO.</u>	<u>PART NAME</u>	<u>QTY.</u>	<u>REMARKS</u>
40	M2561100103	STRIPE	1	
41	M2561100203	STRIPE	2	
42	M2561101303	STRIPE	1	
43	M2561101403	STRIPE	1	
44	M2561101504	STRIPE	1	
45	M2561101604	STRIPE	1	
46	M2561101703	STRIPE	1	
47	M2561101803	STRIPE	1	
48	M9510200002	STICKER, MQ	1	M91020000
49	0600500092	EMBLEM	1	
50	0021106015	MACHINE SCREW	4	
51	M9511200103	DECAL: TIER 4F	1	M91120010
52	M9521200604	DECAL: BONDED NEUTRAL	1	M92120060
53	Y0600500094	DECAL: E-COAT STICKER	1	
54	M9541100004	DECAL: CAUTION EXHAUST FLUID ONLY	1	M94110000
55	M9522000004	DECAL: WATER HEATER	1	S/N 7307148 AND ABOVE
56	M9521002804	DECAL: EMERGENCY STOP BUTTON	1	M92100280 S/N 7307346 AND ABOVE
57	M2551001004	DECAL: OUTPUT TERMINAL BOLT TORQUE	1	M25100100 S/N 7307382 AND ABOVE

PARTS MANUAL

HERE'S HOW TO GET HELP

PLEASE HAVE THE MODEL AND SERIAL
NUMBER ON HAND WHEN CALLING

UNITED STATES

Multiquip Inc.

(310) 537- 3700
6141 Katella Avenue Suite 200
Cypress, CA 90630
E-MAIL: mq@multiquip.com
WEBSITE: www.multiquip.com

CANADA

Multiquip

(450) 625-2244
4110 Industriel Boul.
Laval, Quebec, Canada H7L 6V3
E-MAIL: infocanada@multiquip.com

UNITED KINGDOM

Multiquip (UK) Limited Head Office

0161 339 2223
Unit 2, Northpoint Industrial Estate, Globe Lane,
Dukinfield, Cheshire SK16 4UJ
E-MAIL: sales@multiquip.co.uk

© COPYRIGHT 2024, MULTIQUIP INC.

Multiquip Inc, the MQ logo and the MQ Power logo are registered trademarks of Multiquip Inc. and may not be used, reproduced, or altered without written permission. All other trademarks are the property of their respective owners and used with permission.

This manual MUST accompany the equipment at all times. This manual is considered a permanent part of the equipment and should remain with the unit if resold.

The information and specifications included in this publication were in effect at the time of approval for printing. Illustrations, descriptions, references and technical data contained in this manual are for guidance only and may not be considered as binding. Multiquip Inc. reserves the right to discontinue or change specifications, design or the information published in this publication at any time without notice and without incurring any obligations.

Manufactured for
MQ Power Inc.
by
DENYO MANUFACTURING CORP.

