



# DLW500ESA4

## Welder

### WhisperWeld™

DC Rated Output — 500 Amps

AC Max. Output — 14 kW (14 kVA)

AC Rated Output — 12 kW (12 kVA)

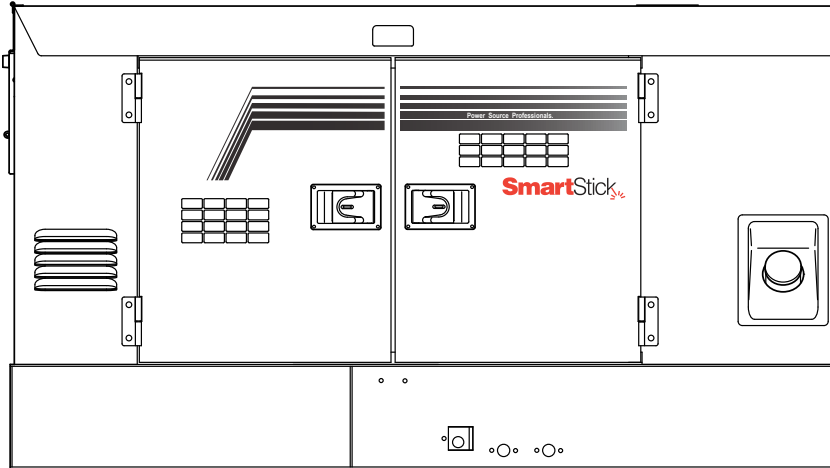

#### STANDARD FEATURES

- Heavy duty, 4-cycle, direct injection, crankcase vent heater, diesel engine provides maximum reliability.
- EPA emissions certified — Tier 4 Final emissions compliant.
- Single-Side Maintenance Design — Quick, direct access to all filters. External fluid drain extensions allow fast, easy service.
- Electronic governor system maintains frequency to  $\pm 0.25\%$
- Sound attenuated, weather resistant, compact steel housing provides operation at 65dB(A) at 23 feet. Fully lockable enclosure allows safe unattended operation.
- E-coat and powder coat paint provides durability and weather protection.
- Internal fuel tank with digital fuel gauge.
- Brushless alternator reduces service and maintenance requirements and meets temperature rise standards for Class F insulation systems.
  - Open delta alternator design provides virtually unlimited excitation for maximum motor starting capability.
  - Automatic voltage regulator (AVR) provides precise regulation.
- Simultaneous AC and DC power.
- Multi-process welding - SMAW, FCAW, GMAW, GTAW and ACAC.
- Independent control of CC/CV selection on single and dual welder outputs.
- Smart Stick function automatically shuts the engine down during periods of no load. The operator only needs to tap the welding rod to the grounded work for the engine to restart.
- E-mode improves fuel efficiency by allowing one operator to weld up to 280 amps or two operators up to 180 amps.
- 14-pin wire feeder connector(s).
- Arc Force control allows the operator to fine tune DC current during low voltage welding conditions which helps in preventing electrodes from sticking during short arc length welding.
- Dual operator output ability.
- Fully-covered power panel — Single phase receptacles allow fast and convenient hookup for most applications.
- Complete generator instrumentation — Includes a 2-pole circuit breaker, AC voltmeter, hour meter, idle control switch, warning lamp display, and ignition switch.
- Automatic safety shutdown system monitors low oil pressure, high water temperature and battery charge via warning lamp display module.
- Full panel GFCI protection - OSHA and NEC compliant.



# DLW500ESA4

## Welder

### SPECIFICATIONS

Generator Specifications	
Design	Revolving field, self-ventilated brushless, drip-proof, single bearing
Armature Connection	Series
Phase	Single Phase (3-wire)
Max. Output	14 kW (14 kVA)
Rated Output	12 kW (12 kVA)
Rated Voltage	120, 240 V
Power Factor	1
Voltage Regulation (No load to full load)	120V ±5% / 240V ±1.5%
Generator RPM	1800
Frequency	60 Hz
No. of Poles	4
Winding Pitch	2/3
No. of Leads	4
Frequency Regulation: No Load to Full Load	3 - 5% of mean value for constant loads from no load to full load.
Frequency Regulation: Steady State	±0.25% of mean value for constant loads from no load to full load.
Insulation	Class F
Sound Level dB(A) Full load at 23 feet	65

Engine Specifications	
Make / Model	Isuzu / 4LE2T
Emissions	EPA Tier 4 Final Certified
Starting System	Electric
Design	4-cycle, water cooled, direct injection, turbocharged, EGR
Displacement	133.0 in <sup>3</sup> (2179 cc)
No. cylinders	4
Bore x Stroke	3.34 x 3.77 in. (85 x 96 mm)
Rated Engine Power Output	40.2 hp (30.0 kW)
Engine Speed	1800 rpm
Oil Capacity	2.75 gallons (10.4 liters)
Coolant Capacity	2.35 gallons (8.9 liters)
Starting System	Electric
Battery	12V 64Ah x 1 (115D31R)

Fuel System		
Recommended Fuel	ASTM-D975-No.1 & No.2-D*	
Fuel Tank Capacity	17.7 gallons (67 liters)	
<b>Fuel Consumption**</b>	<b>gph</b>	<b>lph</b>
At 450A load	1.59	6.01
At 358A load	1.15	4.35
At 225A load	0.84	3.17
At 113A load	0.60	2.27

\* - Use ultra-low sulfur diesel fuel.  
\*\* - DC Welding Current.

Amperage (AC)	
<b>Rated Voltage</b>	<b>Amps</b>
120 Volt	50 x 2 Continuous
240 Volt	50 Continuous

Welding Output (DC)	Constant Voltage (CV)	Constant Current (CC)
<b>Single Operation</b>		
Rated Output (kW)	16.4	17.1
Rated Current (Amps)	450	450
Rated Voltage***	36.5	38.0
Voltage Range	14 ~ 40	N/A
Current Range	N/A	30 ~ 500
Rated Duty Cycle	100%	100%
<b>Dual Operation</b>		
Rated Output (kW)	6.6	7.5
Rated Current (Amps)	250 x 2	250 x 2
Rated Voltage***	26.5	30.0
Voltage Range	14 ~ 29	N/A
Current Range	N/A	30 ~ 280
Rated Duty Cycle	100%	100%

\*\*\* - Rated voltage at 100% duty cycle.

e Mode Selector Switch	Single		Dual	
	Low (1200 rpm)	High (1800 rpm)	Low (1200 rpm)	High (1800 rpm)
LOW	N/L, 30-280A	—	N/L, A+B Total 30-180A	—
HIGH/LOW	N/L	30-500A	N/L	A+B Total 30-280A
HIGH	—	N/L, 30-500A	—	N/L, A+B Total 30-280A

	Single		Dual	
	Low (1200 rpm)	High (1800 rpm)	Low (1200 rpm)	High (1800 rpm)
Current Range	30-280A	30-500A	30-180A	30-280A
Electrode Size	ø3/32" to ø3/16"	ø3/32" to ø5/16"	ø3/32" to ø3/16"	ø3/32" to ø3/16"

### WARRANTY\*

#### Isuzu Engine\*\*

12 months from date of purchase with unlimited hours or 36 months from date of purchase with 3,000 hours (whichever occurs first).

#### Welder

24 months from date of purchase or 2,000 hours (whichever occurs first).

#### Trailer

12 months excluding normal wear items.

\* Refer to the express written, one-year limited warranty sheet for additional information.

\*\* Refer to Isuzu Diesel Engine Limited Warranty for details.

### NOTICE

Specifications sheet is subject to change and is not intended for use in installation design.



# DLW500ESA4

## Welder

### MQ POWER DECIBEL LEVELS

Our soundproof housing allows substantially lower operating noise levels than competitive designs. DLW500ESA4 is at home on construction sites, in residential neighborhoods, and at hospitals — just about anywhere.

- 90 — Subway / truck traffic
- 80 — Average city traffic
- 70 — Inside car at 60 mph
- 65 — DLW500ESA4 at 23 feet
- 60 — Air conditioner at 20 feet
- 50 — Normal conversation

**65.0**  
DECIBELS

### WELDER CONTROL PANEL

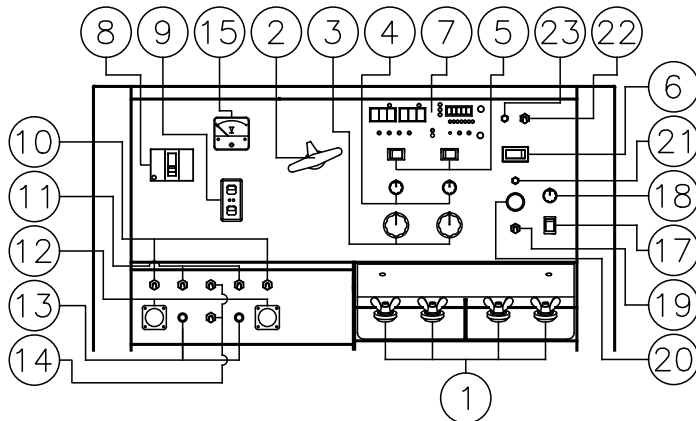

- |   |                                  |
|---|----------------------------------|
| 1. DC Welding Output Terminal           | 10. Local/Feeder Switch          |
| 2. Single - Dual Selector Switch        | 11. Weld Output Switch           |
| 3. Current/Voltage Regulator            | 12. Wire Feeder Socket (14p)     |
| 4. Welding Regulator                    | 13. AC Circuit Protector         |
| 5. Welding Mode Selector Switch (CC/CV) | 14. Polarity Switch              |
| 6. E Mode Selector Switch               | 15. AC Voltmeter                 |
| 7. Digital Panel:                       | 16. Ground Terminal (for bonnet) |
| - DC Weld Meter                         | 17. Idle Stop Switch             |
| - Idle Stop Monitor                     | 18. Time Regulator               |
| - Hour Meter                            | 19. Starter Switch               |
| - Fuel Meter                            | 20. Engine Start Button          |
| - Warning Lamp                          | 21. Operation Lamp               |
| 8. AC Circuit Breaker                   | 22. Engine Diagnostic Switch     |
| 9. GFCI Sensing Module                  | 23. Engine Diagnostic Lamp       |

### OPTIONAL WELDER FEATURES

- **Electrode and Work Clamp Welding Cable** — superior flexibility and durability.
- **Oil Pan Heater** — for easy starting in cold weather climates.
- **Trailer Mounted Package** — Heavy duty highway legal trailer with single axle or tandem axle configurations.

### OPTIONAL TRAILER FEATURES

- **Lockable Trailer Storage Box** — ideal for securing welding cable, tools and supplies (available for the TRLR502 series only).
- **Cable Carriers** — Holds two 100 ft. lengths of 2/0 cable per side of trailer.
- **Coupler** — 2" ball, 2 5/16" ball and 3" pintle.
- **Spare Tire** — with lockable mounting bracket (available for the TRLR502 series only).



# DLW500ESA4

## Welder

### UNIT ONLY DIMENSIONS

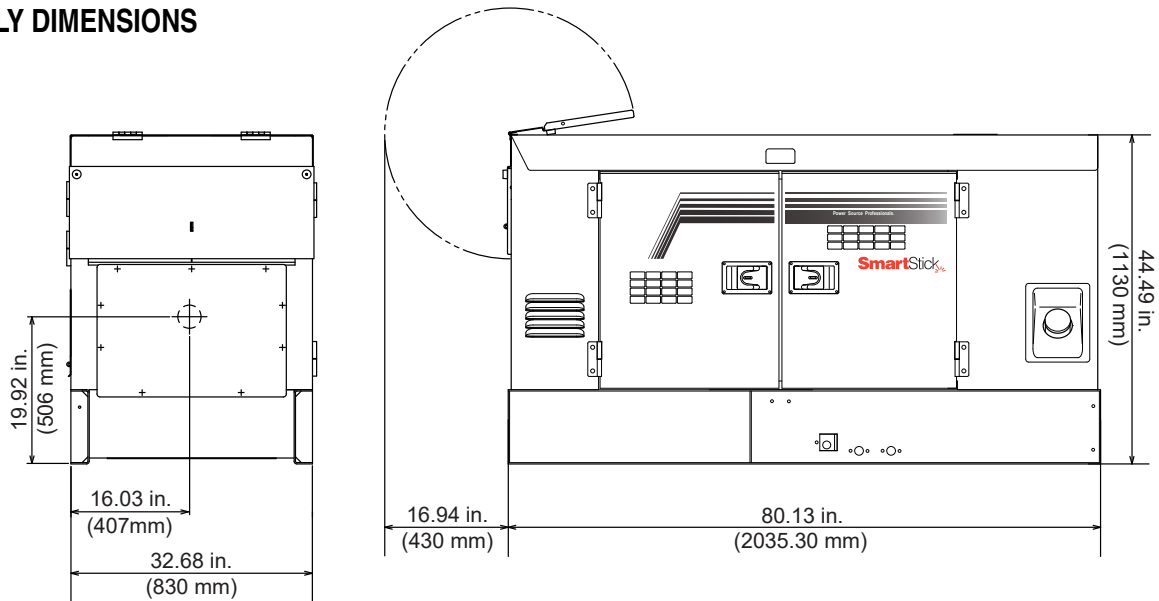

### TRAILER-MOUNTED DIMENSIONS

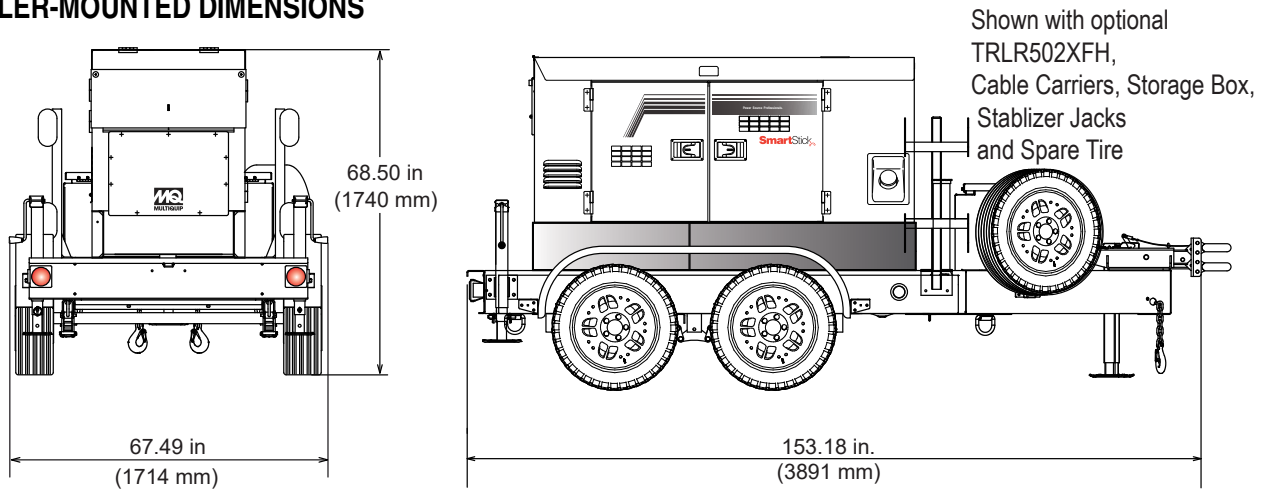

NOTE: Contact Multiquip for TRLR501XFH drawing.

#### DLW500ESA4 Weights\*

Dry Weight	1,960 lbs. (890 kg)
Wet Weight	2,148 lbs. (975 kg)
Max. Lifting Point Capacity	3,030 lbs. (1,374 kg)

\*Weights do not include options.

#### DLW500ESA4 and TRLR502XF Weights\*

Dry Weight (with TRLR502XF)	3,571 lbs. (1,620 kg)
Wet Weight (with TRLR502XF)	4,327 lbs. (1,962 kg)

Welder can be placed on MQ Power Models TRLR501XF (E/H) and TRLR502XF (E/H) Trailers.

#### NOTICE

Features and Specifications are subject to change without notice.



MULTIQUIP  
6141 Katella Avenue Suite 200  
Cypress, CA 90630  
310-537-3700  
E-MAIL: [mq@multiquip.com](mailto:mq@multiquip.com)  
WEBSITE: [www.multiquip.com](http://www.multiquip.com)