

PARTS MANUAL



SmartStick[™]

MODEL DLW500ESA4 WELDER/GENERATOR (ISUZU 4LE2T DIESEL ENGINE)

REF. NO. D6874300704C

Revision #2 (01/23/24)

To find the latest revision of this publication
or associated operation manual, visit
our website at: www.multiquip.com



THIS MANUAL MUST ACCOMPANY THE EQUIPMENT AT ALL TIMES.

**DLW500ESA4
Welder-Generator**

Explanation Of Code In Remarks Column..... 4
Suggested Spare Parts 5

Component Drawings

Generator Assembly 6-7
Control Panel, Upper Assembly..... 8-9
Control Panel, Lower Assembly..... 10-11
Output Terminal Assembly..... 12-13
Electric Parts (1) Assembly..... 14-17
Electric Parts (2) Assembly..... 18-19
Engine And Radiator Assembly 20-23
Battery Assembly 24-25
Muffler Assembly 26-27
Fuel Tank Assembly..... 28-29
Remote Control Assembly (Option)..... 30-31
Enclosure Assembly 32-35
Rubber Seals Assembly 36-37
Nameplate And Decals Assembly..... 38-39

NOTICE
Specifications and part numbers are subject to change without notice.

EXPLANATION OF CODE IN REMARKS COLUMN

The following section explains the different symbols and remarks used in the Parts section of this manual. Use the help numbers found on the back page of the manual if there are any questions.

NOTICE

The contents and part numbers listed in the parts section are subject to change without notice. Multiquip does not guarantee the availability of the parts listed.

SAMPLE PARTS LIST

NO.	PART NO.	PART NAME	QTY.	REMARKS
1	12345	BOLT	1	INCLUDES ITEMS W/%
2%		WASHER, 1/4 IN.		NOT SOLD SEPARATELY
2%	12347	WASHER, 3/8 IN. ...	1	MQ-45T ONLY
3	12348	HOSE	A/R	MAKE LOCALLY
4	12349	BEARING	1	S/N 2345B AND ABOVE

NO. Column

Unique Symbols — All items with same unique symbol (@, #, +, %, or >) in the number column belong to the same assembly or kit, which is indicated by a note in the “Remarks” column.

Duplicate Item Numbers — Duplicate numbers indicate multiple part numbers, which are in effect for the same general item, such as different size saw blade guards in use or a part that has been updated on newer versions of the same machine.

NOTICE

When ordering a part that has more than one item number listed, check the remarks column for help in determining the proper part to order.

PART NO. Column

Numbers Used — Part numbers can be indicated by a number, a blank entry, or TBD.

TBD (To Be Determined) is generally used to show a part that has not been assigned a formal part number at the time of publication.

A blank entry generally indicates that the item is not sold separately or is not sold by Multiquip. Other entries will be clarified in the “Remarks” Column.

QTY. Column

Numbers Used — Item quantity can be indicated by a number, a blank entry, or A/R.

A/R (As Required) is generally used for hoses or other parts that are sold in bulk and cut to length.

A blank entry generally indicates that the item is not sold separately. Other entries will be clarified in the “Remarks” Column.

REMARKS Column

Some of the most common notes found in the “Remarks” Column are listed below. Other additional notes needed to describe the item can also be shown.

Assembly/Kit — All items on the parts list with the same unique symbol will be included when this item is purchased.

Indicated by:

“INCLUDES ITEMS W/(unique symbol)”

Serial Number Break — Used to list an effective serial number range where a particular part is used.

Indicated by:

“S/N XXXXX AND BELOW”

“S/N XXXX AND ABOVE”

“S/N XXXX TO S/N XXX”

Specific Model Number Use — Indicates that the part is used only with the specific model number or model number variant listed. It can also be used to show a part is NOT used on a specific model or model number variant.

Indicated by:

“XXXXX ONLY”

“NOT USED ON XXXX”

“Make/Obtain Locally” — Indicates that the part can be purchased at any hardware shop or made out of available items. Examples include battery cables, shims, and certain washers and nuts.

“Not Sold Separately” — Indicates that an item cannot be purchased as a separate item and is either part of an assembly/kit that can be purchased, or is not available for sale through Multiquip.

SUGGESTED SPARE PARTS

DLW500ESA4 WELDER/GENERATOR

1 to 3 units

Qty.	P/N	Description
1	0601820664	AUTOMATIC VOLTAGE REG.
1	Y0601873310	CIRCUIT PROT., 2P 30A
1	0601806425	CIRCUIT PROT., 2P 30A
1	0601806424	CIRCUIT PROT., 1P 30A
1	Y0601806433	CIRCUIT PROT., 2P 20A
1	Y0601840208	RHEOSTAT (VOLT. REG.)
1	0601840103	KNOB
1	0601840095	RHEOSTAT (WELD. REG.)
1	0601840100	KNOB
1	0601840095	RHEOSTAT (TIME REG.)
1	0601840170	KNOB
5	0601806645	FUSE, 10A
5	Y0601806646	FUSE, 20A
5	0601806644	FUSE, 30A
5	0601806640	FUSE, 65A

ISUZU 4LE2T DIESEL ENGINE

1 to 3 units

Qty.	P/N	Description
5	2944566410	ELEMENT, OIL FILTER
3	8981731650	KIT, FUEL FEED PUMP
1	D6311501103	HOSE, RADIATOR UPPER
1	D6311501203	HOSE, RADIATOR LOWER
1	0602011079	CAP, RADIATOR
1	0845500104	CAP, FUEL TANK
6	0810105900	FILTER, FUEL
6	8982402800	ELEMENT, FUEL FILTER (M)
6	8982402790	ELEMENT, FUEL FILTER (P)
3	PMAF25436	ELEMENT, A/C OUTER
3	P822769	ELEMENT, A/C INNER

NOTICE

Part numbers on this Suggested Spare Parts list may supersede/replace the part numbers shown in the following parts lists.

GENERATOR ASSY.

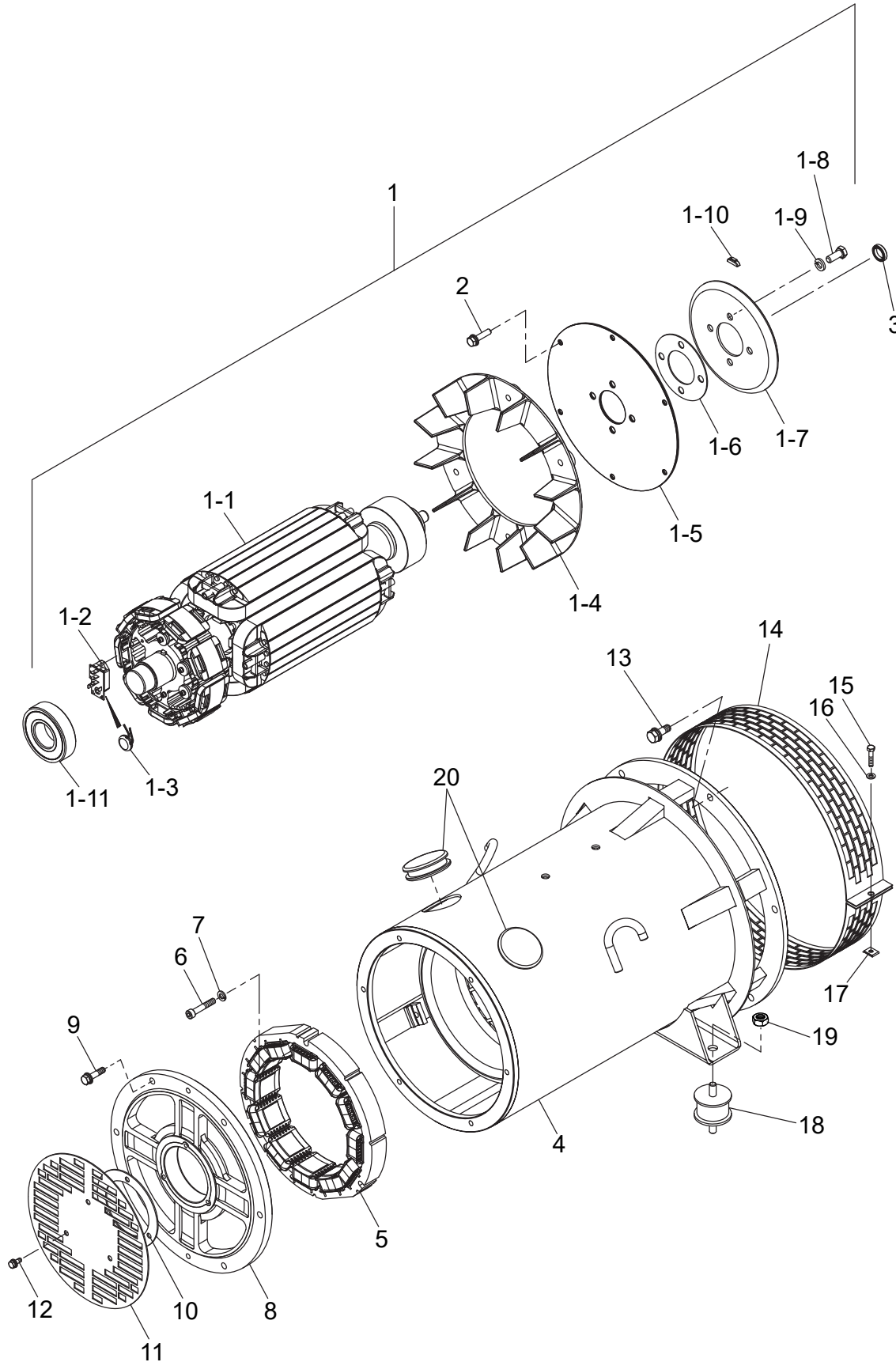

GENERATOR ASSY.

<u>NO.</u>	<u>PART NO.</u>	<u>PART NAME</u>	<u>QTY.</u>	<u>REMARKS</u>
1	D6110100102	ROTOR ASSY.....	1.....	INCLUDES ITEMS W/#
1-1#		FIELD ASSY.	1	
1-2#	0601821374	RECTIFIER	1	
1-3#	Y0601822696	SURGE ABSORBER	1	
1-4#	8001070003	FAN	1	
1-5#	8351611004	COUPLING DISK	2	
1-6#	8351612004	WASHER, COUPLING HUB	1	
1-7#	B1112300003	BALANCING PLATE	1.....	PURCHASE SET OF 1-10 AT THE SAME TIME
1-8#	0105091025	HEX. HEAD BOLT.....	4.....	REPLACES P/N 0010310025
1-9#	0042610000	LOCK WASHER	4	
1-10#	0601000209	BALANCING WEIGHT KIT	1	
1-11#	042006308	BEARING	1.....	REPLACES P/N 0071906308
2	0012808035	HEX. HEAD BOLT	6	
3	0070506803	BEARING	1	
4	D6130100503	STATOR ASSY.	1	
5	B1138000003	FIELD ASSY., EXCITER	1	
6	0016008045	HEX. SOCKET HEAD CAP SCREW	3	
7	0042508000	LOCK WASHER	3	
8	8351315003	END BRACKET	1	
9	0017108035	HEX. HEAD BOLT	6	
10	8351312004	PACKING	1	
11	8351331004	COVER, SUCTION	1	
12	0017106016	HEX. HEAD BOLT	3	
13	012010030	HEX. HEAD BOLT.....	6.....	REPLACES P/N 0012810030
14	B0155400204	COVER, FAN	1	
15	0010006030	HEX. HEAD BOLT.....	1.....	REPLACES P/N 0010106030
16	952404470	FLAT WASHER.....	1.....	REPLACES P/N 0041206000
17	020106050	NUT.....	1.....	REPLACES P/N 0600815000
18	7085419004	RUBBER SUSPENSION	2	
19	021112140	HEX. NUT	2.....	REPLACES P/N 0207010000
20	0801358204	GROMMET	1	

CONTROL PANEL, UPPER ASSY.

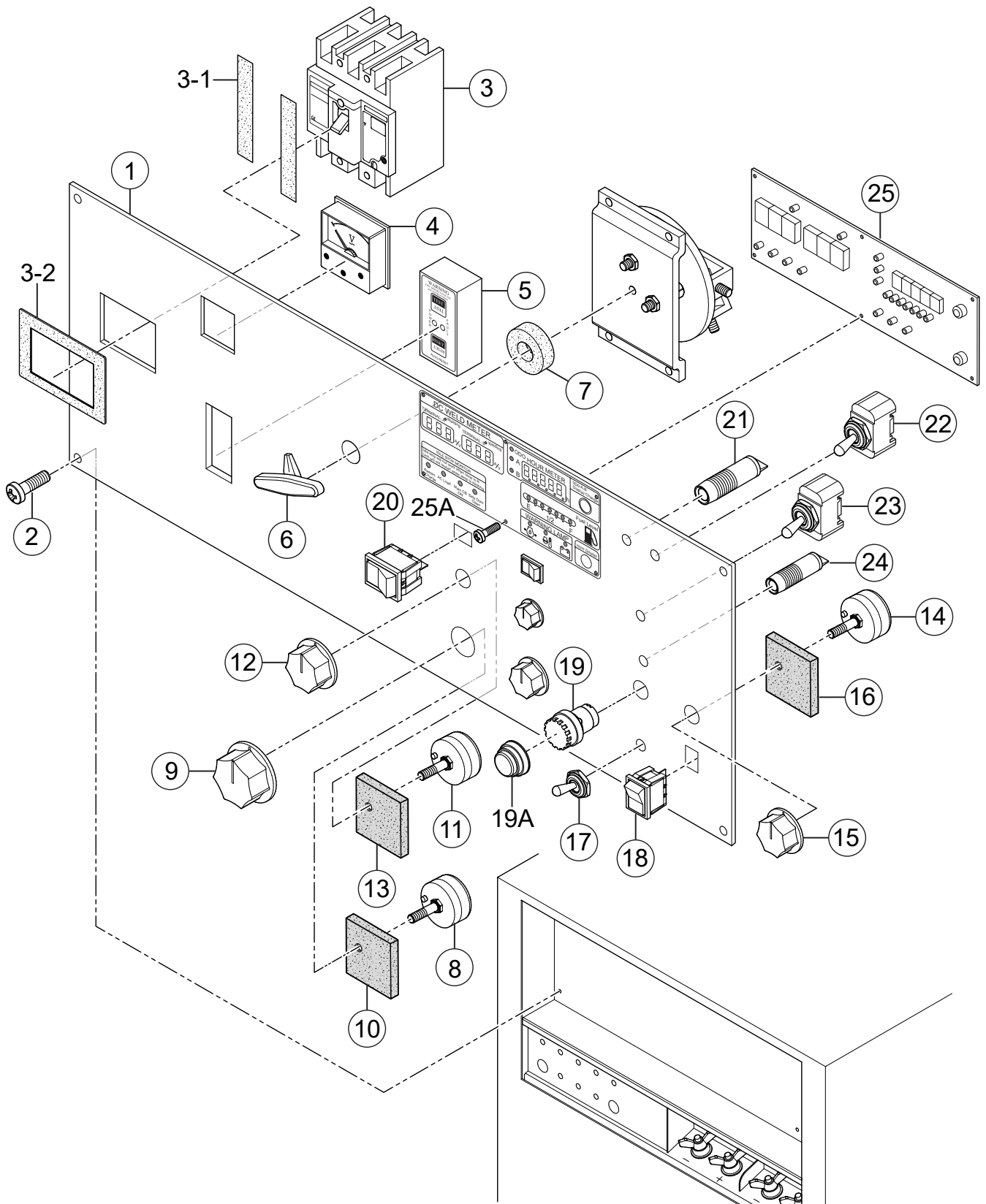

CONTROL PANEL, UPPER ASSY.

<u>NO.</u>	<u>PART NO.</u>	<u>PART NAME</u>	<u>QTY.</u>	<u>REMARKS</u>
1	D6511303002	CONTROL PANEL	1	S/N 5880101 AND BELOW
1	D6511303012	CONTROL PANEL	1	S/N 5880102 AND ABOVE
2	Y0021806130	MACHINE SCREW	6	
3	Y0601872279	CIRCUIT BREAKER, 3P 60A	1	
3-1	0317900080	RUBBER SEAL	2	
3-2	D5491400204	RUBBER SEAL	1	
4	0601800281	AC VOLTMETER, 5A 0-150/300V	1	
5	0601829301	EARTH LEAKAGE RELAY, 120V	1	
6	Y0601803076	CHANGE-OVER SWITCH	1	
7	8705945004	RUBBER SEAL	1	
8	Y0601840208	RHEOSTAT (CURRENT/VOLTAGE REG.)	2	
9	0601840103	KNOB	2	
10	0801883003	INSULATOR	2	
11	0601840095	RHEOSTAT (WELDING REGULATOR)	2	
12	0601840100	KNOB	2	
13	0801883003	INSULATOR	2	
14	0601840095	RHEOSTAT (TIME REGULATOR)	1	
15	0601840170	KNOB	1	
16	0801883003	INSULATOR	1	
17	0601830731	STARTER SWITCH	1	
18	0601831600	SWITCH, IDLE STOP SELECTOR	1	
19	0601831966	SWITCH, TIME REGULATOR	1	
19A	0601832048	CAP	1	
20	0601831600	SWITCH, WELDING MODE SELECTOR	2	
21	Y0601816716	ENGINE DIAGNOSTIC LAMP	1	
22	Y0601831376	SWITCH, ENGINE DIAGNOSTIC	1	
23	Y0601831605	SWITCH, E MODE SELECTOR	1	S/N 5880101 AND BELOW
23	Y0601831379	SWITCH, E MODE SELECTOR	1	S/N 5880102 AND ABOVE
24	Y0601816706	OPERATION LAMP	1	
25	D6267200004	DIGITAL PANEL	1	
25A	0027103005	MACHINE SCREW	6	

CONTROL PANEL, LOWER ASSY.

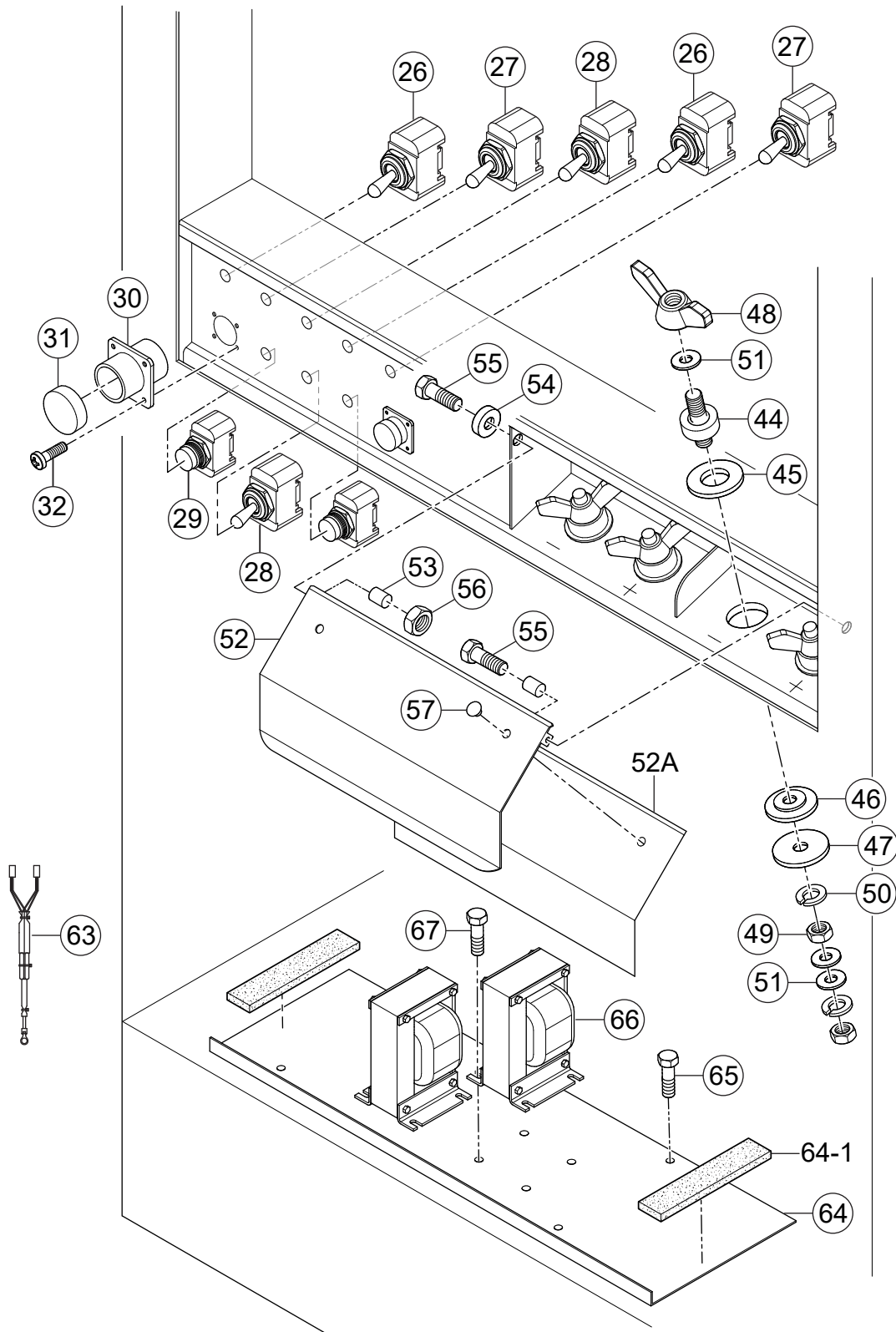

CONTROL PANEL, LOWER ASSY.

<u>NO.</u>	<u>PART NO.</u>	<u>PART NAME</u>	<u>QTY.</u>	<u>REMARKS</u>
26	0601831311	SWITCH, LOCAL/REMOTE REGULATOR	2	
27	Y0601831365	SWITCH, LOCAL/REMOTE WELD OUTPUT	2	
28	Y0601831368	SWITCH, POLARITY	2	
29	Y0601873320	AC CIRCUIT BREAKER	2	
30	Y0601816631	REMOTE CONNECTOR	2	
31	Y0601811431	CAP	2	
32	Y0029004012	MACHINE SCREW	8	
44	0801888204	OUTPUT TERMINAL, WELDING	4	
45	0801840104	INSULATOR WASHER	4	
46	0801840004	INSULATOR WASHER	4	
47	6109170	SET, WASHER, OUTPUT TERMINAL	4	REPLACES P/N 0801841204
48	022910220	WING NUT	4	REPLACES P/N 0801884004
49	0039312000	HEX. NUT	8	REPLACES P/N 0039512000
50	0042212000	LOCK WASHER	8	
51	0041412000	FLAT WASHER	12	
52	D6237101203	COVER, OUTPUT TERMINAL	1	
52A	D4237401004	RUBBER SHEET	1	
53	0821800014	COLLAR	2	
54	0805088004	STAY RUBBER	1	
55	Y0016906020	HEX. HEAD BOLT	2	
56	Y0207006000	HEX. NUT	1	
57	0845031504	CAP	2	
63	D4268304714	NOISE FILTER	2	
64	D6264900704	BRACKET	1	
64-1	Y0414200295	RUBBER SEAL	2	
65	0016906015	HEX. HEAD BOLT	4	
66	D6264500103	DC REACTOR	2	
67	0016906015	HEX. HEAD BOLT	8	

OUTPUT TERMINAL ASSY.

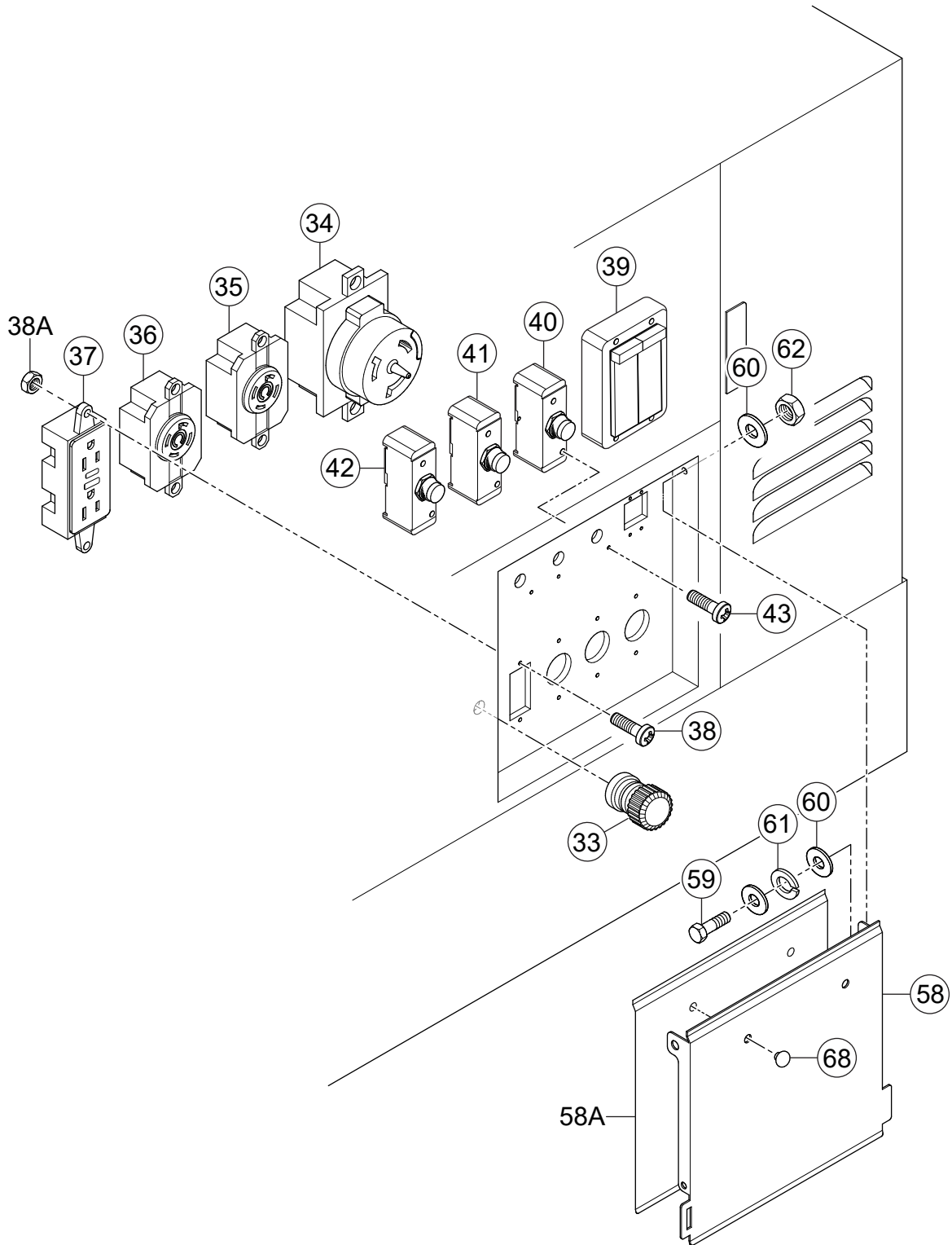

OUTPUT TERMINAL ASSY.

<u>NO.</u>	<u>PART NO.</u>	<u>PART NAME</u>	<u>QTY.</u>	<u>REMARKS</u>
33	0601815109	GROUND TERMINAL	1	
34	0601814014	RECEPTACLE, CS-6369L	1	
35	0601811033	RECEPTACLE, L6-30R	1	
36	0601811031	RECEPTACLE, L5-30R	1.....	REPLACES P/N 0601811035
37	0601814034	RECEPTACLE, 5-20R GFWR2-E (GFCI)	1	
38	0027104015	MACHINE SCREW	8	
38A	OEMAA8	HEX. NUT	8.....	REPLACES P/N 0207004000
39	Y0601873310	CIRCUIT PROTECTOR, 2P 30A	1	
40	0601806425	CIRCUIT PROTECTOR, 2P 30A	1	
41	0601806424	CIRCUIT PROTECTOR, 1P 30A	1	
42	Y0601806433	CIRCUIT PROTECTOR, 2P 20A	1	
43	0021003005	MACHINE SCREW	10	
58	D6237101103	COVER, OUTPUT TERMINAL	1	
58A	D4237401104	RUBBER SHEET	1	
59	0010112040	HEX. HEAD BOLT	2	
60	031112230	FLAT WASHER.....	6.....	REPLACES P/N 0041212000
61	0605050060	CONICAL LOCK WASHER	2	
62	0030012000	HEX. NUT	2	
68	0845031504	CAP	2	

ELECTRIC PARTS (1) ASSY.

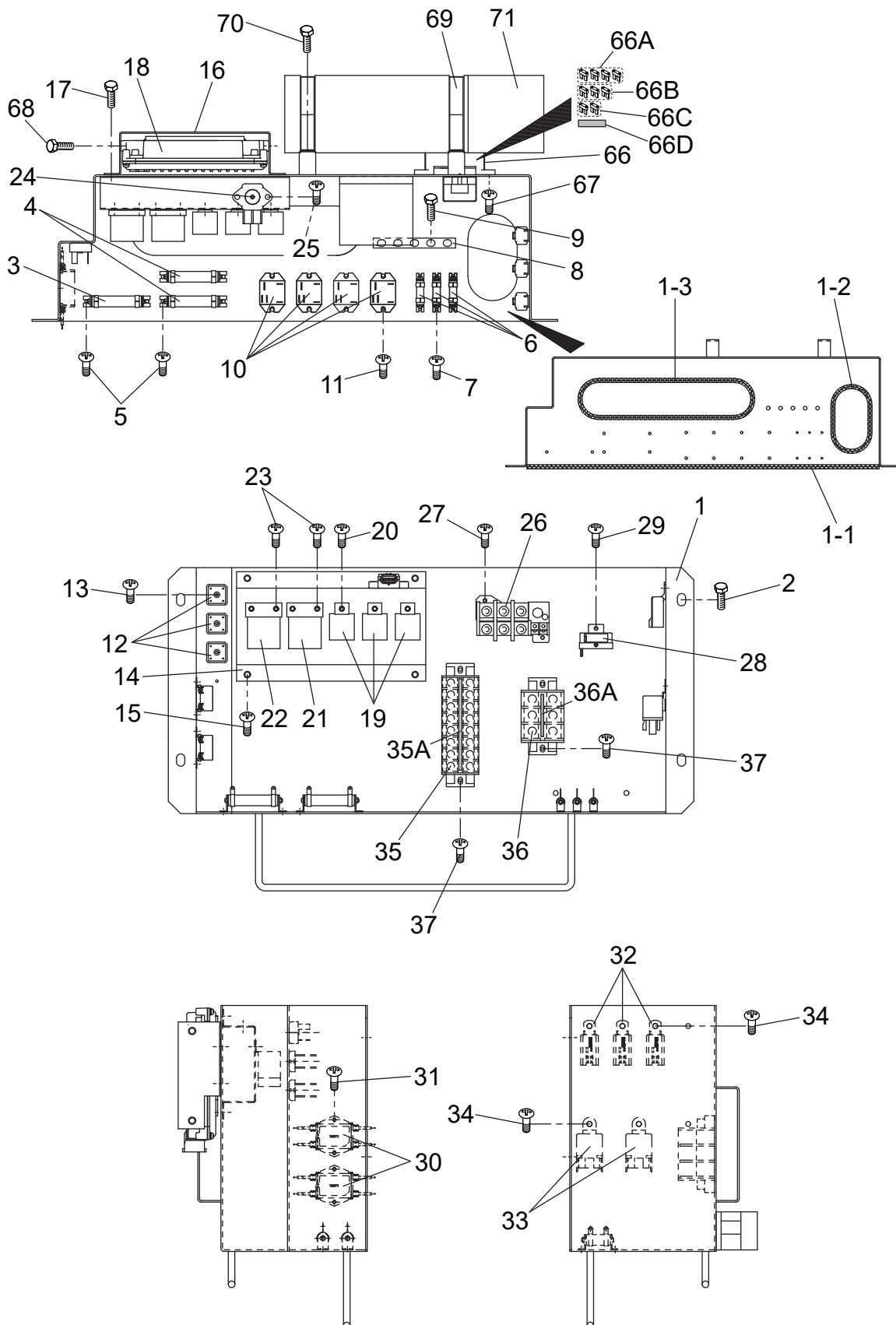

ELECTRIC PARTS (1) ASSY.

<u>NO.</u>	<u>PART NO.</u>	<u>PART NAME</u>	<u>QTY.</u>	<u>REMARKS</u>
1	D6214000902	CONTROL BOX	1	
1-1	0226900570	RUBBER SEAL	1	
1-2	0226900300	RUBBER SEAL	1	
1-3	0226900650	RUBBER SEAL	1	
2	011008020	HEX. HEAD BOLT.....	4	REPLACES P/N 0016908020
3	0601842384	RESISTOR, 20W 50Ω	1	
4	0601842198	RESISTOR, 20W 1KΩ.....	2	REPLACES P/N 0601842262
5	0027104015	MACHINE SCREW	6	
6	Y0601842548	RESISTOR, 5W 60Ω	3	
7	0027104015	MACHINE SCREW	6	
8	8511864601A	PLATE.....	1	REPLACES P/N 8511864604
9	0016906015	HEX. HEAD BOLT	5	
10	Y0601820901	RELAY, DC12V1C	4	
11	0027104015	MACHINE SCREW	8	
12	0601823204	RECTIFIER	3	
13	0027103015	MACHINE SCREW	3	
14	D6214601104	BRACKET, RELAY	1	
15	0016906015	HEX. HEAD BOLT	4	
16	D6214601004	BRACKET	1	
17	0016906015	HEX. HEAD BOLT	4	
18	8976670710	ECM.....	1	REPLACES P/N Y0602202724
19	5825500290	MAIN RELAY.....	3	REPLACES P/N Y0602301400
20	0027105015	MACHINE SCREW	3	
21	8944001061	STARTER RELAY.....	1	REPLACES P/N 0602202502
22	8970119490	GLOW PLUG, RELAY.....	1	REPLACES P/N 0602202685
23	0027105015	MACHINE SCREW	4	
24	8972177780	SENSOR, BAROMETIC PRESS.....	1	REPLACES P/N 0602130220
25	0027105015	MACHINE SCREW	2	
26	Y0601820879	OVER CURRENT RELAY	1	
27	0027104015	MACHINE SCREW	2	
28	Y0601804203	DC CURRENT TRANSFORMER	1	
29	0027104015	MACHINE SCREW	2	
30	Y0601825139	NOISE FILTER	2	
31	0027103015	MACHINE SCREW	4	
32	0601823707	RELAY	3	
33	0601823754	RELAY	2	
34	0027105015	MACHINE SCREW	5	
35	Y0601815426	TERMINAL BLOCK, KT-30 8P	1	
35A	D9521003804	DECAL; SYMBOL MARK	1	
36	Y0601815811	TERMINAL BLOCK, KT-60 3P	1	
36A	D9521003704	DECAL; SYMBOL MARK	1	
37	0027104015	MACHINE SCREW	4	

ELECTRIC PARTS (1) ASSY. (CONT'D.)

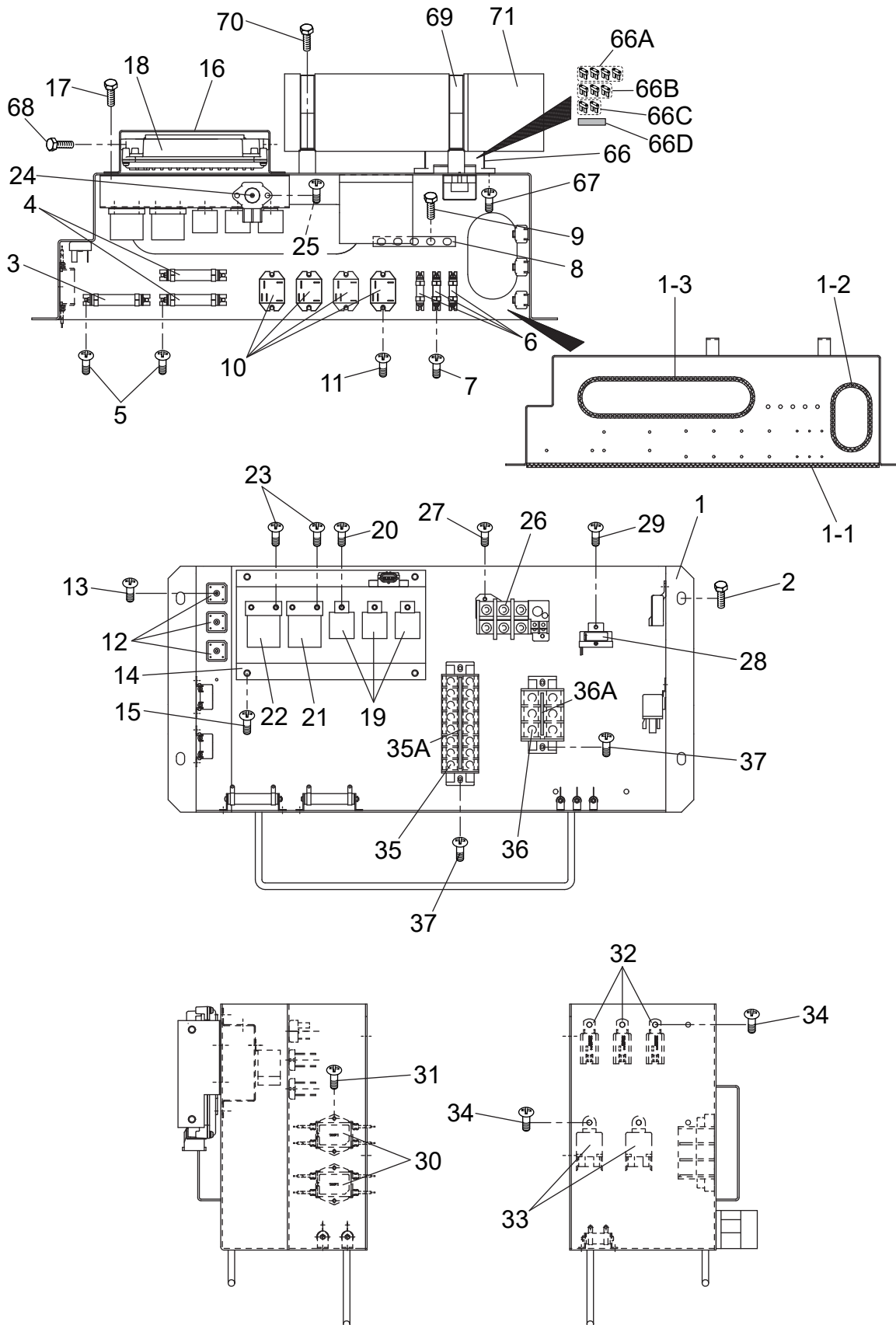

ELECTRIC PARTS (1) ASSY. (CONT'D.)

<u>NO.</u>	<u>PART NO.</u>	<u>PART NAME</u>	<u>QTY.</u>	<u>REMARKS</u>
66	D6214600704	FUSE BOX ASSY.....	1.....	INCLUDES ITEMS W/%
66A%	0601806645	FUSE, 10A	4	
66B%	Y0601806646	FUSE, 20A	3	
66C%	0601806644	FUSE, 30A	2	
66D%	D6551009704	DECAL	1	
67	0021005020	MACHINE SCREW	2	
68	0016906015	HEX. HEAD BOLT	4	
69	D6484600204	CLAMPER	2	
70	011206020	HEX. HEAD BOLT.....	4.....	REPLACES P/N 0016906020
71	0600800321	MANUAL CASE	1	

ELECTRIC PARTS (2) ASSY.

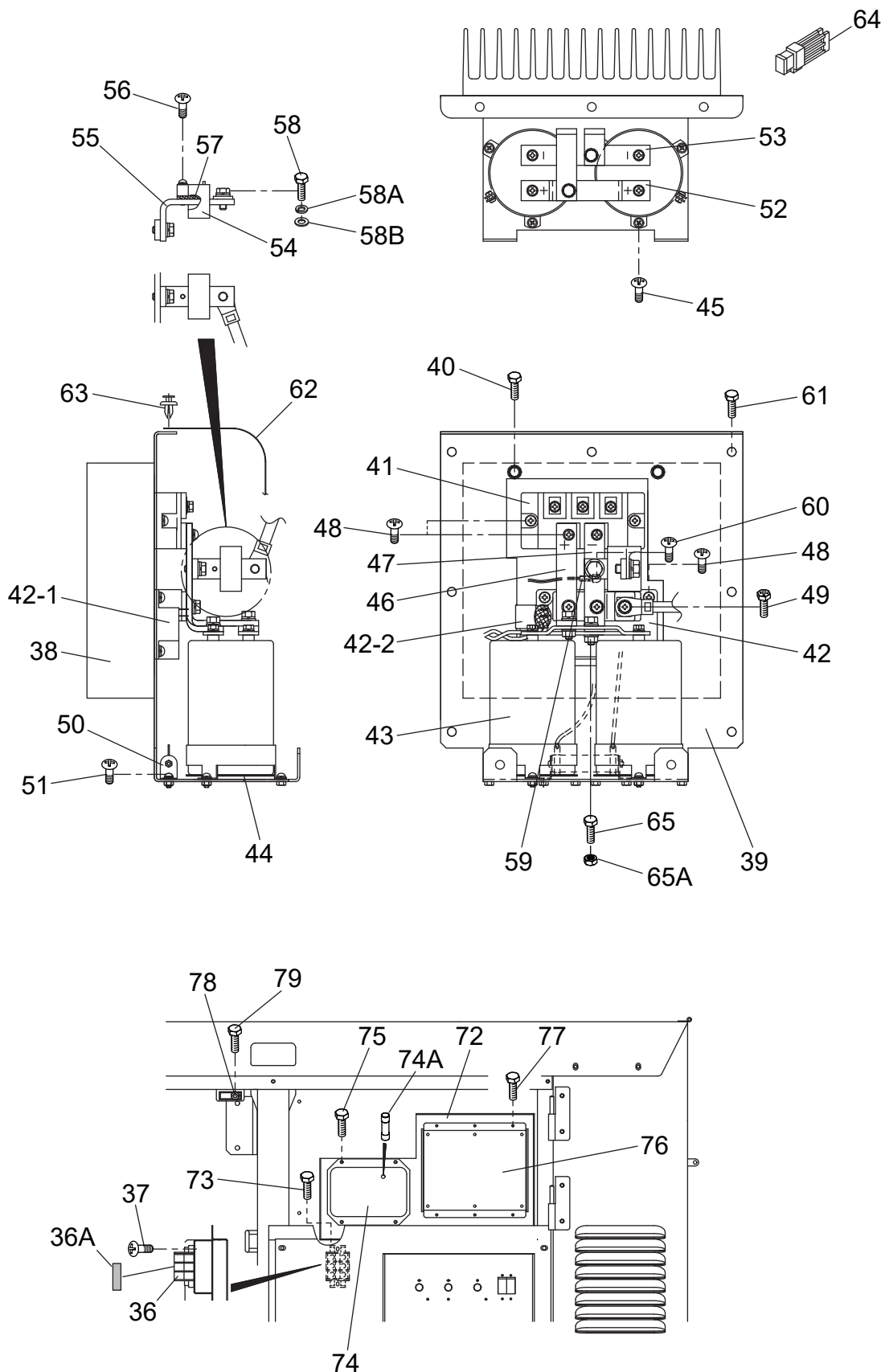

ELECTRIC PARTS (2) ASSY.

<u>NO.</u>	<u>PART NO.</u>	<u>PART NAME</u>	<u>QTY.</u>	<u>REMARKS</u>
36	Y0601815811	TERMINAL BLOCK, KT-60 3P	1	
36A	D9521003704	DECAL; SYMBOL MARK	1	
37	0027104015	MACHINE SCREW	2	
38	D6267302504	COOLING FIN	2	
39	D6261602504	BRACKET	2	
40	0016906015	HEX. HEAD BOLT	8	
41	0601823256	RECTIFIER	2	
42	D4268000403	IGBT MODULE ASSY.	2	INCLUDES ITEMS W/#
42-1#	0601821258	IGBT MODULE	2	
42-2#	D9925800044	IGBT PROTECTIVE UNIT	2	
43	Y0601826144	CONDENSER	4	
44	D6261800904	INSULATOR RUBBER	4	
45	0027104010	MACHINE SCREW	8	
46	D6267302604	CONNECTION PLATE	2	
47	D6267302704	CONNECTION PLATE	2	
48	0027105016	MACHINE SCREW	16	
49	0017806014	HEX. HEAD BOLT	6	
50	0601842198	RESISTOR, 20W 1KΩ	2	REPLACES P/N 0601842262
51	0027104010	MACHINE SCREW	4	
52	D4268304204	CONNECTION PLATE	2	
53	D6267302804	CONNECTION PLATE	2	
54	0601804202	DC CURRENT TRANSFORMER	2	
55	D3267300604	CONNECTION PLATE	2	
56	0027104020	MACHINE SCREW	2	
57	D4235400004	INSULATOR	2	
58	0019008016	HEX. HEAD BOLT	4	
58A	0040008000	LOCK WASHER	4	
58B	0042708000	FLAT WASHER	4	
59	0601803660	THERMISTOR	2	
60	0021003010	MACHINE SCREW	2	
61	0016906015	HEX. HEAD BOLT	14	
62	D6261700004	COVER, ELECTRIC PARTS	2	
63	Y0605011412	RIVET	8	
64	0601806640	FUSE, 65A	2	
65	011206020	HEX. HEAD BOLT.....	4	REPLACES P/N 0017106020
65A	0023706000	HEX. NUT	4	REPLACES P/N 0207206000
72	D6261602403	BRACKET	1	
73	011008020	HEX. HEAD BOLT.....	4	REPLACES P/N 0016908020
74	0601820664	AUTOMATIC VOLTAGE REGULATOR.....	1	INCLUDES ITEMS W/\$
74A\$	0601806681	FUSE, 250V 5A	1	
75	Y0016905015	HEX. HEAD BOLT	4	
76	D6267200104	CONTROL UNIT	1	
77	0016906015	HEX. HEAD BOLT	6	
78	Y0601830347	DOOR SWITCH.....	3	S/N 5895115 AND BELOW
78	Y0601830361	DOOR SWITCH.....	3	S/N 5895116 AND ABOVE
79	0027104030	MACHINE SCREW	6	

ENGINE AND RADIATOR ASSY.

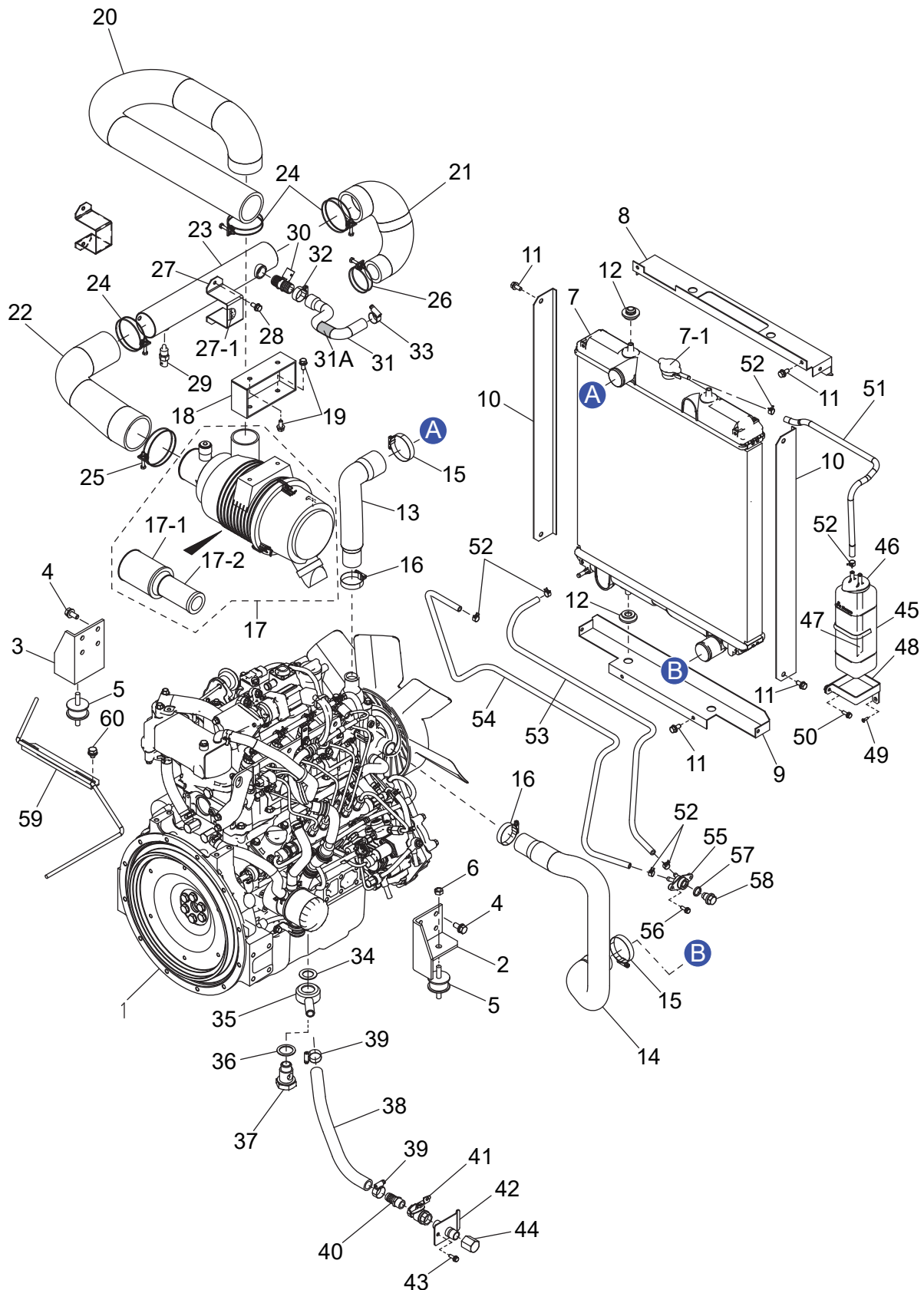

ENGINE AND RADIATOR ASSY.

<u>NO.</u>	<u>PART NO.</u>	<u>PART NAME</u>	<u>QTY.</u>	<u>REMARKS</u>
1	D6924200144	ENGINE, ISUZU 4LE2T	1	
2	B1304202104	ENGINE FOOT	1	
3	B1305200004	ENGINE FOOT	1	
4	012210025	HEX. HEAD BOLT.....	8.....	REPLACES P/N 0012310025
5	0605000066	RUBBER SUSPENSION	2	
6	021112140	HEX. NUT	2.....	REPLACES P/N 0207010000
7	0602012773	RADIATOR.....	1.....	INCLUDES ITEMS W/%
7-1%	0602011079	CAP, RADIATOR	1	
8	D6311100804	BRACKET, RADIATOR	1	
9	D6311100904	BRACKET, RADIATOR	1	
10	D6311101004	BRACKET, RADIATOR	2	
11	011008020	HEX. HEAD BOLT.....	8.....	REPLACES P/N 0016908020
12	B1312600004	RUBBER MOUNT	4	
13	D6311501103	RADIATOR HOSE	1	
14	D6311501203	RADIATOR HOSE	1	
15	0605515139	HOSE BAND	2	
16	0605515136	HOSE BAND	2	
17	D6924200154	AIR CLEANER.....	1.....	INCLUDES ITEMS W/#
17-1#	PMAF25436	ELEMENT AIR CLEANER, OUTER.....	1.....	REPLACES P/N 0602046309
17-2#	P822769	ELEMENT AIR CLEANER, INNER.....	1.....	REPLACES P/N Y0602046633
18	D6374200704	BRACKET, AIR CLEANER	1	
19	011008020	HEX. HEAD BOLT.....	4.....	REPLACES P/N 0016908020
20	D6374101303	HOSE, AIR CLEANER	1	
21	D6374101103	HOSE, AIR CLEANER	1	
22	D6374101403	HOSE, AIR CLEANER	1	
23	D6374000103	PIPE, AIR CLEANER	1	
24	0605515018	HOSE BAND, ø80	3	
25	0605515008	HOSE BAND, ø90	1	
26	0605515001	HOSE BAND, ø60	1	
27	D6374200904	BRACKET, AIR CLEANER PIPE	1	
27-1	Y0222100060	RUBBER SEAL	1	
28	011008020	HEX. HEAD BOLT.....	2.....	REPLACES P/N 0016908020
29	8921468300	SENSOR, INLET AIR TEMP.	1.....	REPLACES P/N 0603210240
30	8981924670	PCV HEATER	1.....	REPLACES P/N Y0602044300
31	D6327100004	BLOW-BY HOSE	1	
31A	Y0378100170	SEROFLEX TUBE	1	
32	0605515074	HOSE BAND	1	
33	06015515198	HOSE BAND.....	1.....	REPLACES P/N 0605515064
34	0802024004	PACKING	1	
35	C9101000104	PIPE JOINT	1	
36	0805008004	PACKING	1	
37	W0802025004	OIL DRAIN JOINT	1	
38	0265801000	DRAIN HOSE	1	
39	Y0605515053	HOSE BAND	2	
40	0602022202	HOSE JOINT	1	

ENGINE AND RADIATOR ASSY. (CONT'D.)

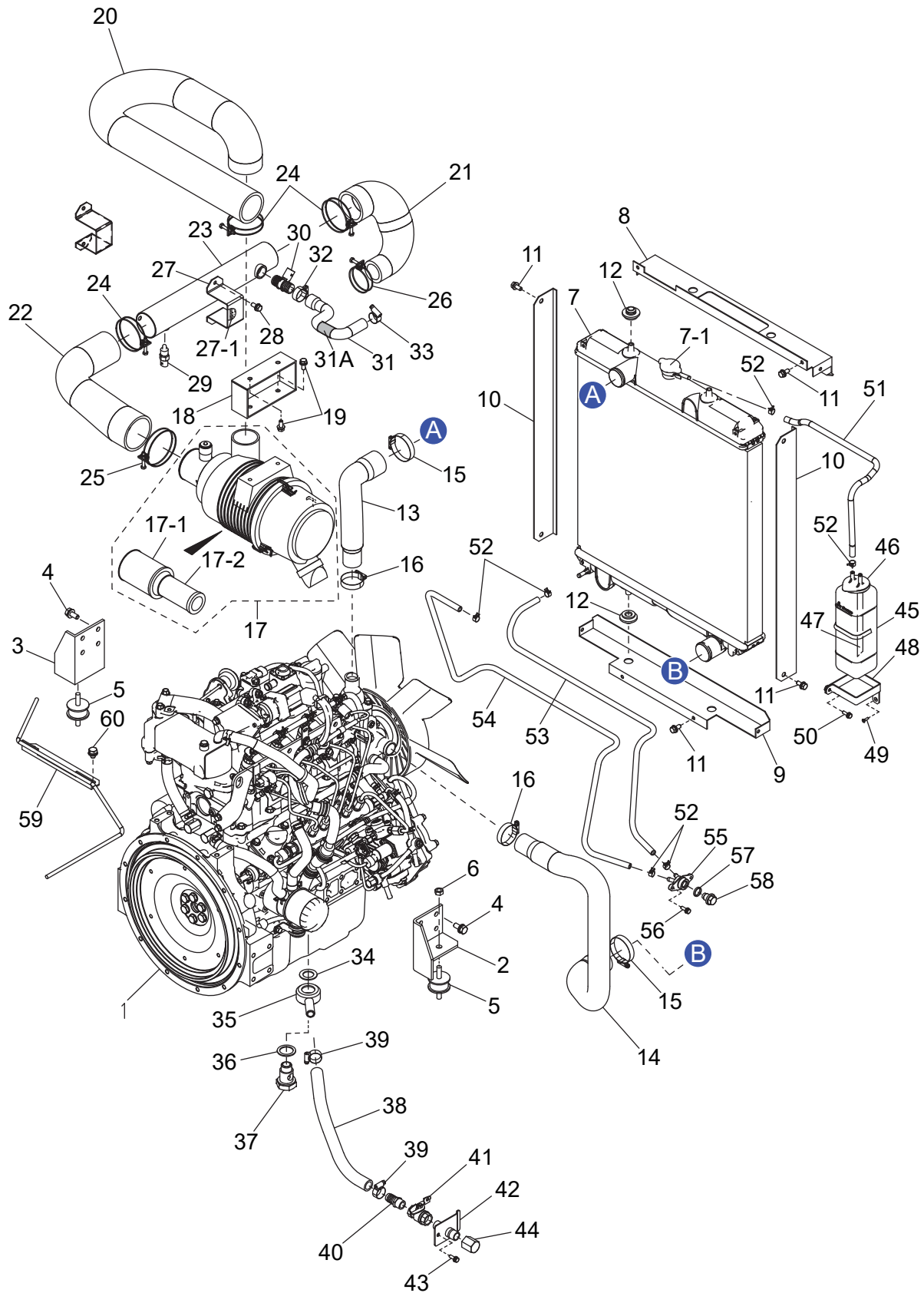

ENGINE AND RADIATOR ASSY. (CONT'D.)

<u>NO.</u>	<u>PART NO.</u>	<u>PART NAME</u>	<u>QTY.</u>	<u>REMARKS</u>
41	Y0603325067	VALVE	1	
42	D9201000104	OIL DRAIN PIPE	1	
43	011206020	HEX. HEAD BOLT.....	1.....	REPLACES P/N 0016906020
44	B9201200104	DRAIN PLUG	1	
45	0802081403	RESERVE TANK	1	
46	0802081104	CAP, RESERVE TANK	1	
47	0199100215	HOSE	1	
48	D4317100304	BRACKET, RESERVE TANK	1	
49	0021104015	MACHINE SCREW	2	
50	011606025	HEX. HEAD BOLT.....	1.....	REPLACES P/N 0016906025
51	0199900550	HOSE	1	
52	0605515094	HOSE BAND, Ø12	6	
53	0199901500	HOSE.....	1.....	S/N 5887702 AND BELOW
53	0199901100	HOSE.....	1.....	S/N 5887703 AND ABOVE
54	Y0199901290	HOSE	1	
55	1622014103	DRAIN JOINT	1	
56	011206020	HEX. HEAD BOLT.....	2.....	REPLACES P/N 0016906020
57	0150000018	O-RING	1	
58	0802011104	DRAIN BOLT	1	
59	D6358300003	CLAMPER ROD	1	
60	0017110015	HEX. HEAD BOLT	2	

BATTERY ASSY.

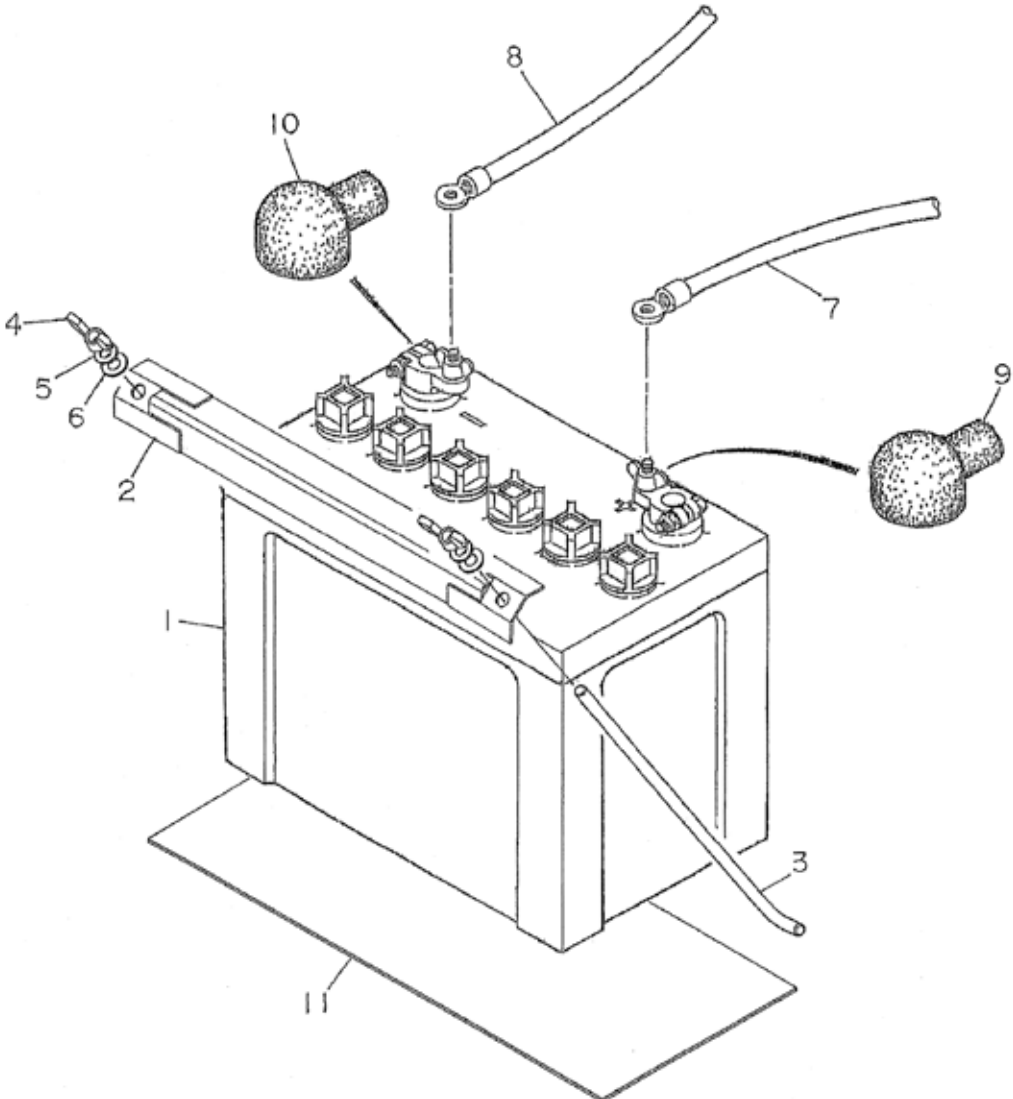

BATTERY ASSY.

<u>NO.</u>	<u>PART NO.</u>	<u>PART NAME</u>	<u>QTY.</u>	<u>REMARKS</u>
1	Y0165311531	BATTERY, 115D31R	1	
2	D6344200104	BATTERY BAND	1	
3	B9105200004	BATTERY BOLT	2	
4	57216	WING NUT WASHER	2.....	REPLACES P/N 0037808000
5	0040008000	LOCK WASHER	2	
6	0401450080	FLAT WASHER.....	2.....	REPLACES P/N 0041208000
7		BATTERY CABLE	1	
8		BATTERY CABLE	1	
9	0845040414	TERMINAL CAP, POSITIVE	1	
10	0845041304	TERMINAL CAP, NEGATIVE	1	
11	D6344200304	BATTERY SHEET.....	1.....	S/N 5887703 AND ABOVE

MUFFLER ASSY.

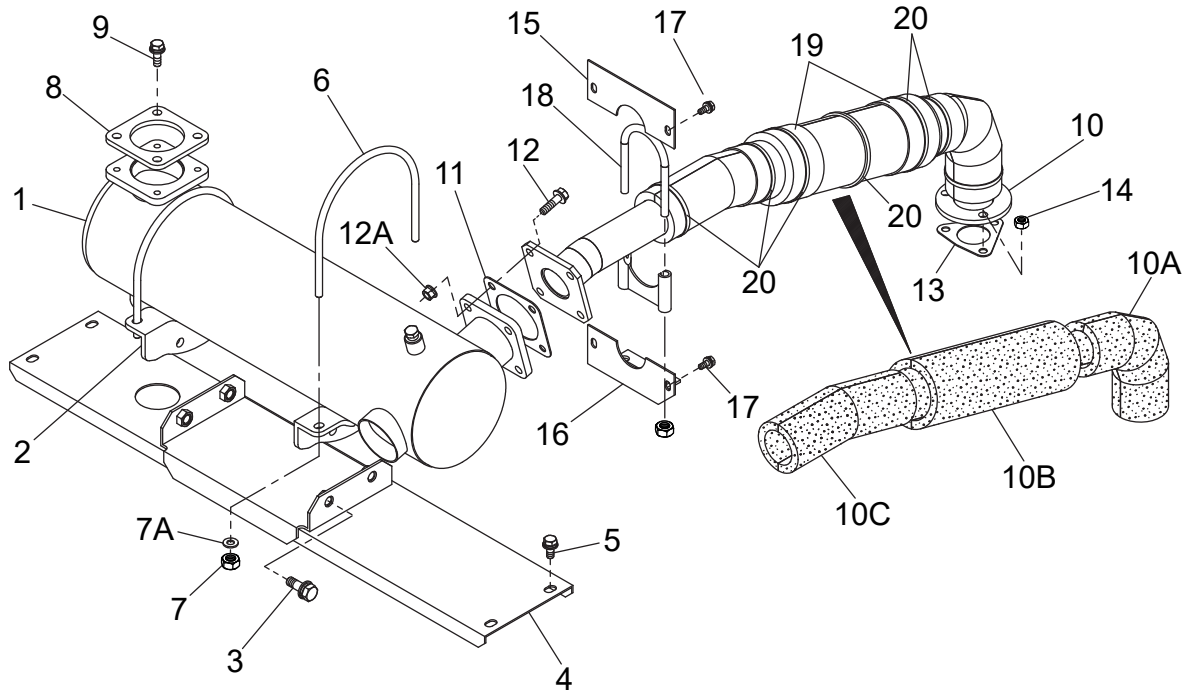

MUFFLER ASSY.

<u>NO.</u>	<u>PART NO.</u>	<u>PART NAME</u>	<u>QTY.</u>	<u>REMARKS</u>
1	8982353890	DOC.....	1.....	REPLACES P/N Y0602330111
2	8982284330	DOC SUPPORT.....	2.....	REPLACES P/N 0602330210
3	0012310030	HEX. HEAD BOLT	4	
4	D6331400603	BRACKET	1	
5	001230802	HEX. HEAD BOLT	4	
6	8982103230	U-BOLT.....	2.....	REPLACES P/N Y0602322091
7	0207608000	U-NUT	4	
7A	0401450080	FLAT WASHER.....	4.....	REPLACES P/N 0041208000
8	D6334300104	GASKET	1	
9	011208025	HEX. HEAD BOLT.....	4.....	REPLACES P/N 0016908025
10	D6334001203	EXHAUST PIPE	1	
10A	D6331400304	WARM COVER, EXHAUST PIPE	1	
10B	D6331401304	WARM COVER, EXHAUST PIPE	1	
10C	D6331402004	WARM COVER, EXHAUST PIPE	1	
11	8973731080	GASKET.....	1.....	REPLACES P/N Y0602320212
12	8980435280	HEX. HEAD BOLT.....	4.....	REPLACES P/N Y0602322090
12A	8971616070	HEX. NUT.....	4.....	REPLACES P/N Y0602323007
13	8973679180	GASKET.....	1.....	REPLACES P/N Y0602320211
14	0207108000	HEX. NUT	3	
15	D6331400204	COVER, EXHAUST PIPE	1	
16	D6331400104	BRACKET, EXHAUST PIPE	1	
17	0016906015	HEX. HEAD BOLT	4	
18	Y0602326066	U-BOLT	1	
19	Y0272100300	HEAT SHIELD TAPE	2	
20	Y0601001104	BAND	7	

FUEL TANK ASSY.

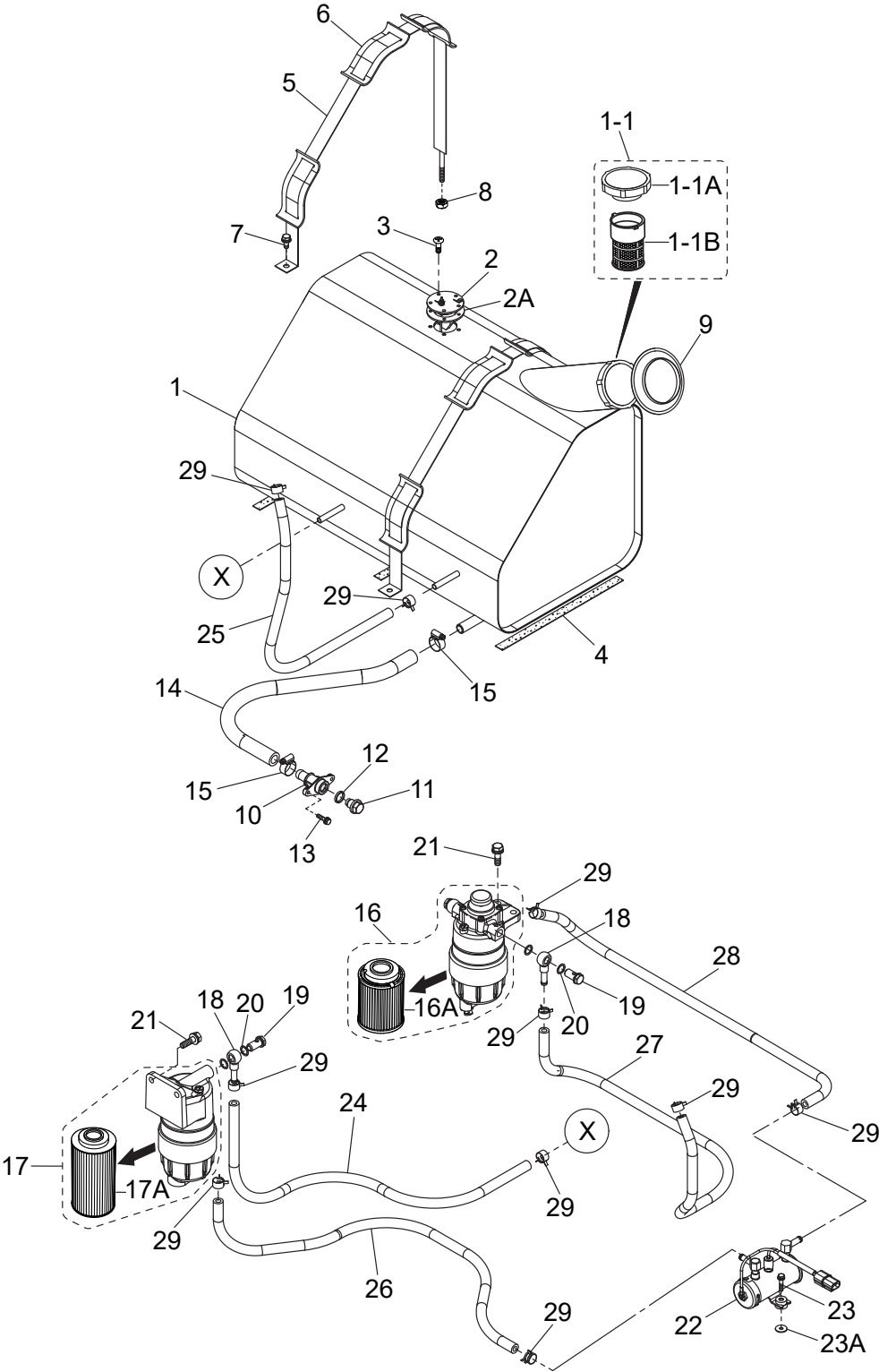

FUEL TANK ASSY.

<u>NO.</u>	<u>PART NO.</u>	<u>PART NAME</u>	<u>QTY.</u>	<u>REMARKS</u>
1	D6364001103	FUEL TANK	1	
1-1	A9924800024	CAP, FUEL TANK ASSY.....	1.....	INCLUDES ITEMS W/#
1-1A#	0845500104	CAP, FUEL TANK.....	1.....	REPLACES P/N W0810105800
1-1B#	0810105900	FUEL FILTER	1	
2	D6924300034	SENDER, FUEL GAUGE	1	
2A	B3924300184	GASKET	1	
3	0022905015	MACHINE SCREW	5	
4	Y0310600310	TANK SHEET	3	
5	D6364201004	TANK BAND	2	
6	0805003414	PAD, TANK BAND	6	
7	011008020	HEX. HEAD BOLT.....	2.....	REPLACES P/N 0017108020
8	0207308000	HEX. NUT	2	
9	0845039604	RUBBER SEAL	1	
10	1502025103C	DRAIN JOINT	1.....	REPLACES P/N 1502025103
11	0802011104	PLUG	1	
12	0150000018	O-RING, A P18	1	
13	011606025	HEX. HEAD BOLT.....	2.....	REPLACES P/N 0016906025
14	0191500700	DRAIN HOSE	1	
15	0605515073	HOSE BAND	2	
16	8982369900	FUEL FILTER (MAIN)	1.....	REPLACES P/N 0602042428 INCLUDES ITEMS W/\$
16A\$	8982402800	ELEMENT, FUEL FILTER	1.....	REPLACES P/N Y0602042508
17	8982369910	FUEL FILTER (PRE).....	1.....	REPLACES P/N 0602042429 INCLUDES ITEMS W/%
17A%	8982402790	ELEMENT, FUEL FILTER	1.....	REPLACES P/N Y0602042507
18	8981263320	PIPE JOINT	4.....	REPLACES P/N Y0602042623
19	1096751930	EYE BOLT.....	4.....	REPLACES P/N Y0602042624
20	8982513450	GASKET	8.....	REPLACES P/N Y0602042642
21	012210035	HEX. HEAD BOLT.....	4.....	REPLACES P/N 0017110035
22	8980682751	FUEL PUMP.....	1.....	REPLACES P/N 0602023240
23	Y0016906035	HEX. HEAD BOLT	2	
23A	0805014504	FLAT WASHER	2	
24	Y0191301140	RETURN HOSE	1	
25	Y0191300990	RETURN HOSE	1	
26	Y0191300940	SUCTION HOSE	1	
27	Y0191301210	SUCTION HOSE	1	
28	Y0191300860	SUCTION HOSE	1	
29	0605515109	HOSE BAND	10	

REMOTE CONTROL ASSY. (OPTION)

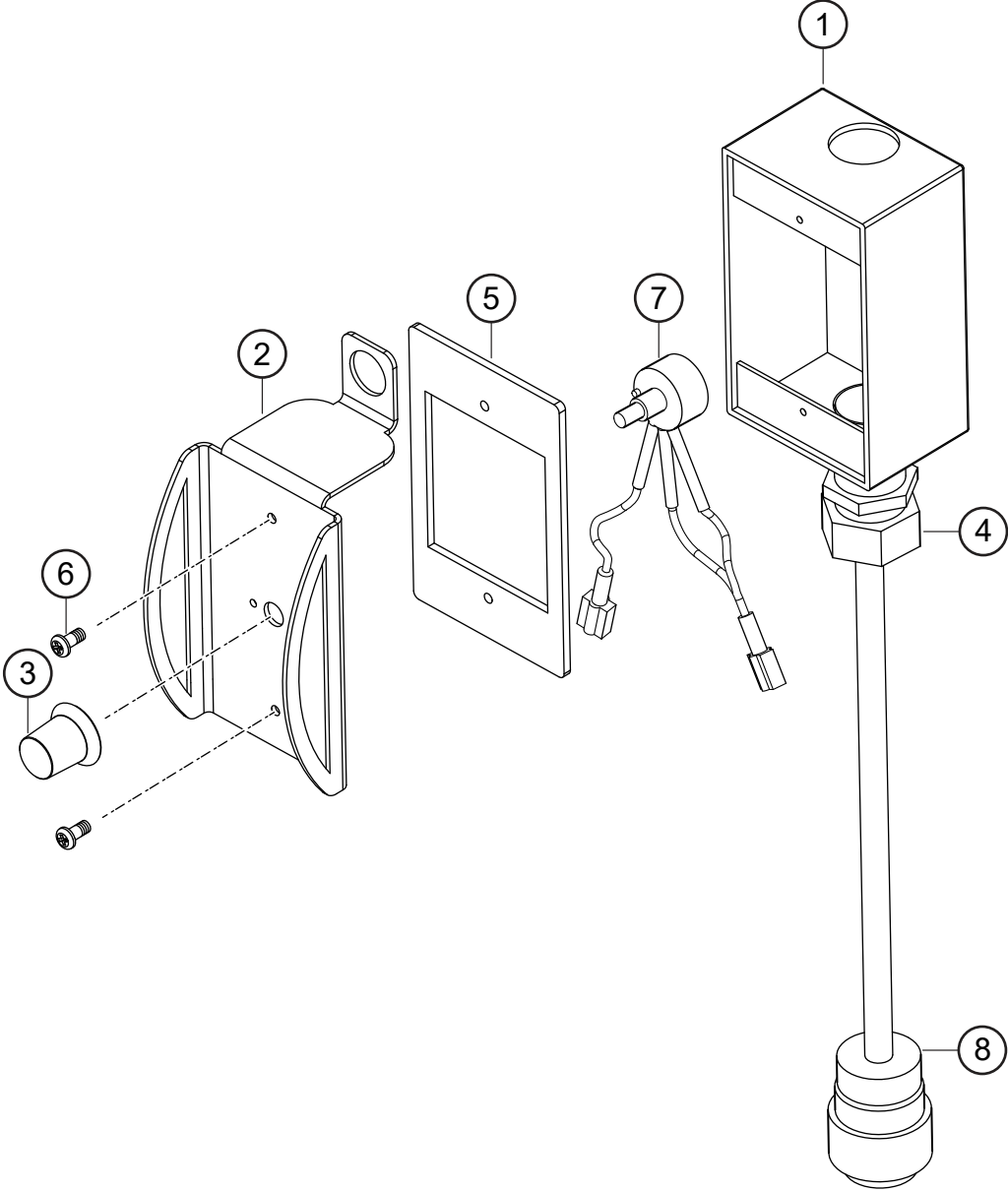

REMOTE CONTROL ASSY. (OPTION)

<u>NO.</u>	<u>PART NO.</u>	<u>PART NAME</u>	<u>QTY.</u>	<u>REMARKS</u>
1	14292	BOX, ELECTRICAL 4 X 3 X 2	1	
2	14293	COVER, ELECTRICAL BOX	1	
3	14294	KNOB, ROUND SKIRTED	1	
4	14295	FITTING, COMPRESSION CABLE	1	
5	14301	GASKET, FOAM ELECTRICAL	1	
6	19298	SCREW, PHP 6-32 X3/8	2	
7	EE63046	VOLTAGE CONTROL ASSY., 10KΩ, 3-WIRE	1	
8	EE63047	CABLE ASSEMBLY	1	

ENCLOSURE ASSY.

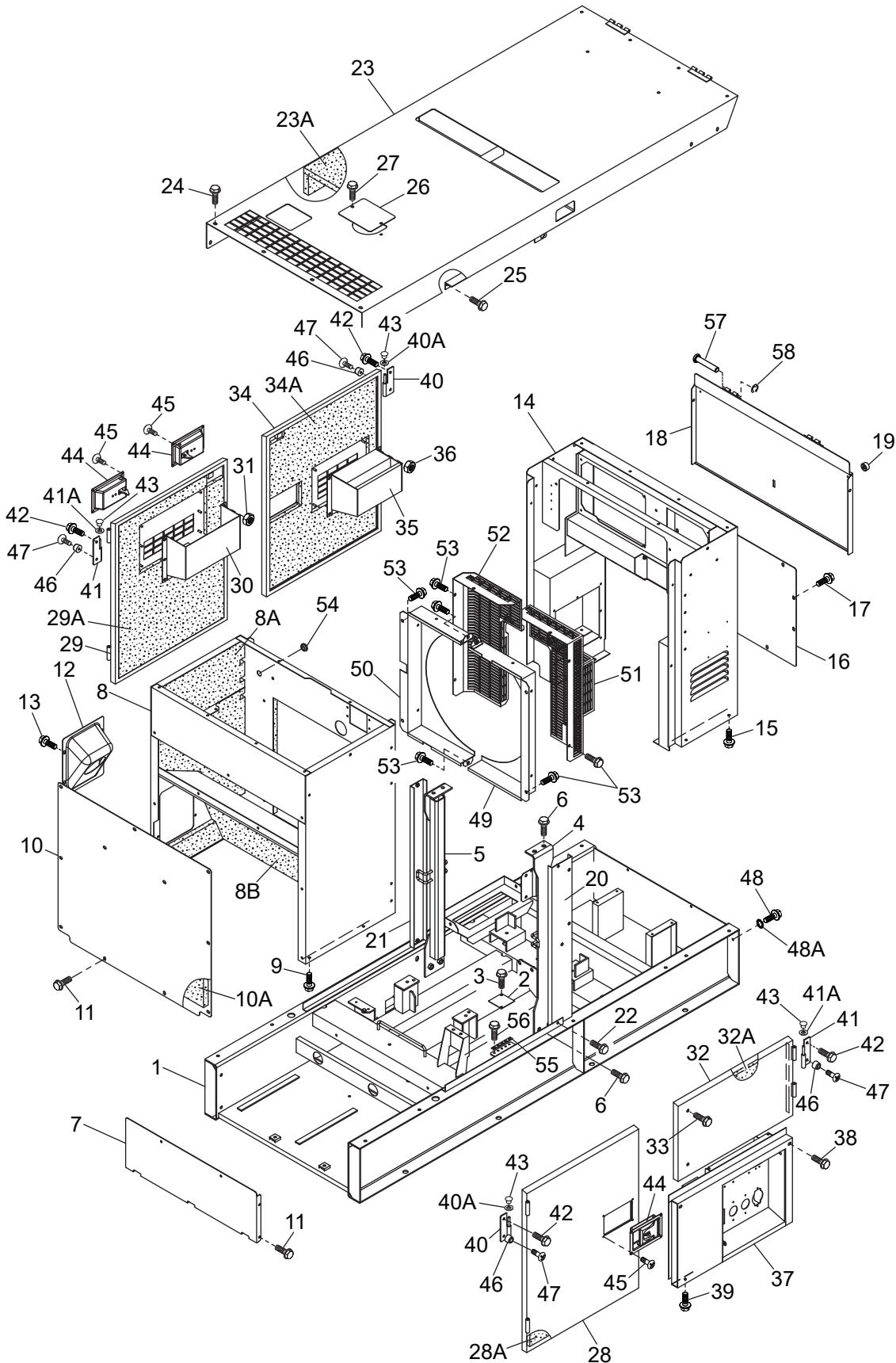

ENCLOSURE ASSY.

<u>NO.</u>	<u>PART NO.</u>	<u>PART NAME</u>	<u>QTY.</u>	<u>REMARKS</u>
1	D6414001702	BASE	1	
2	D3414800104	FLOOR PANEL	1	
3	0016906015	HEX. HEAD BOLT	2	
4	D6434000303	CENTER FRAME	1	
5	D6434000203	CENTER FRAME	1	
6	0012312030	HEX. HEAD BOLT	8	
7	D6414400004	FRONT COVER	1	
8	D6424001402	FRONT FRAME	1	
8A	D6494101803	LINING	1	
8B	D6497100504	LINING	1	
9	011008020	HEX. HEAD BOLT.....	4.....	REPLACES P/N 0016908020
10	D6424200904	COVER, FRONT FRAME	1	
10A	D6494101904	LINING	1	
11	011008020	HEX. HEAD BOLT.....	15.....	REPLACES P/N 0016908020
12	0845039703	FILLER BRACKET	1	
13	011008020	HEX. HEAD BOLT.....	4.....	REPLACES P/N 0016908020
14	D6444002602	REAR FRAME	1	
15	011008020	HEX. HEAD BOLT.....	4.....	REPLACES P/N 0016908020
16	D6444301503	COVER, REAR FRAME	1	
17	011008020	HEX. HEAD BOLT.....	9.....	REPLACES P/N 0016908020
18	D6444201403	REAR DOOR	1	
19	0601851613	STOPPER	2	
20	D6434100204	CENTER PANEL	1	
21	D6434100104	CENTER PANEL	1	
22	0016906015	HEX. HEAD BOLT	4	
23	D6464001002	ROOF PANEL.....	1.....	S/N 5895115 AND BELOW
23	D6464001302	ROOF PANEL.....	1.....	S/N 5895116 AND ABOVE
23A	D6494500703	LINING	1	
24	011008020	HEX. HEAD BOLT.....	18.....	REPLACES P/N 0016908020
25	0016906015	HEX. HEAD BOLT	4	
26	8452023004	COVER, RADIATOR CAP	1	
27	0016906015	HEX. HEAD BOLT	2	
28	D6454001703	SIDE DOOR.....	1.....	S/N 5895115 AND BELOW
28	D6454002303	SIDE DOOR.....	1.....	S/N 5895116 AND ABOVE
28A	D6494403004	LINING.....	1.....	S/N 5895115 AND BELOW
28A	D6494403014	LINING.....	1.....	S/N 5895116 AND ABOVE
29	D6454001603	SIDE DOOR.....	1.....	S/N 5895115 AND BELOW
29	D6454002203	SIDE DOOR.....	1.....	S/N 5895116 AND ABOVE
29A	D6494402904	LINING	1	
30	D6454301004	DUCT	1	
31	0176060030	HEX. NUT.....	7.....	REPLACES P/N 0207006000
32	D6454001903	SIDE DOOR	1	
32A	D6494403204	LINING	1	
33	Y0016908050	HEX. HEAD BOLT	2	

ENCLOSURE ASSY. (CONT'D.)

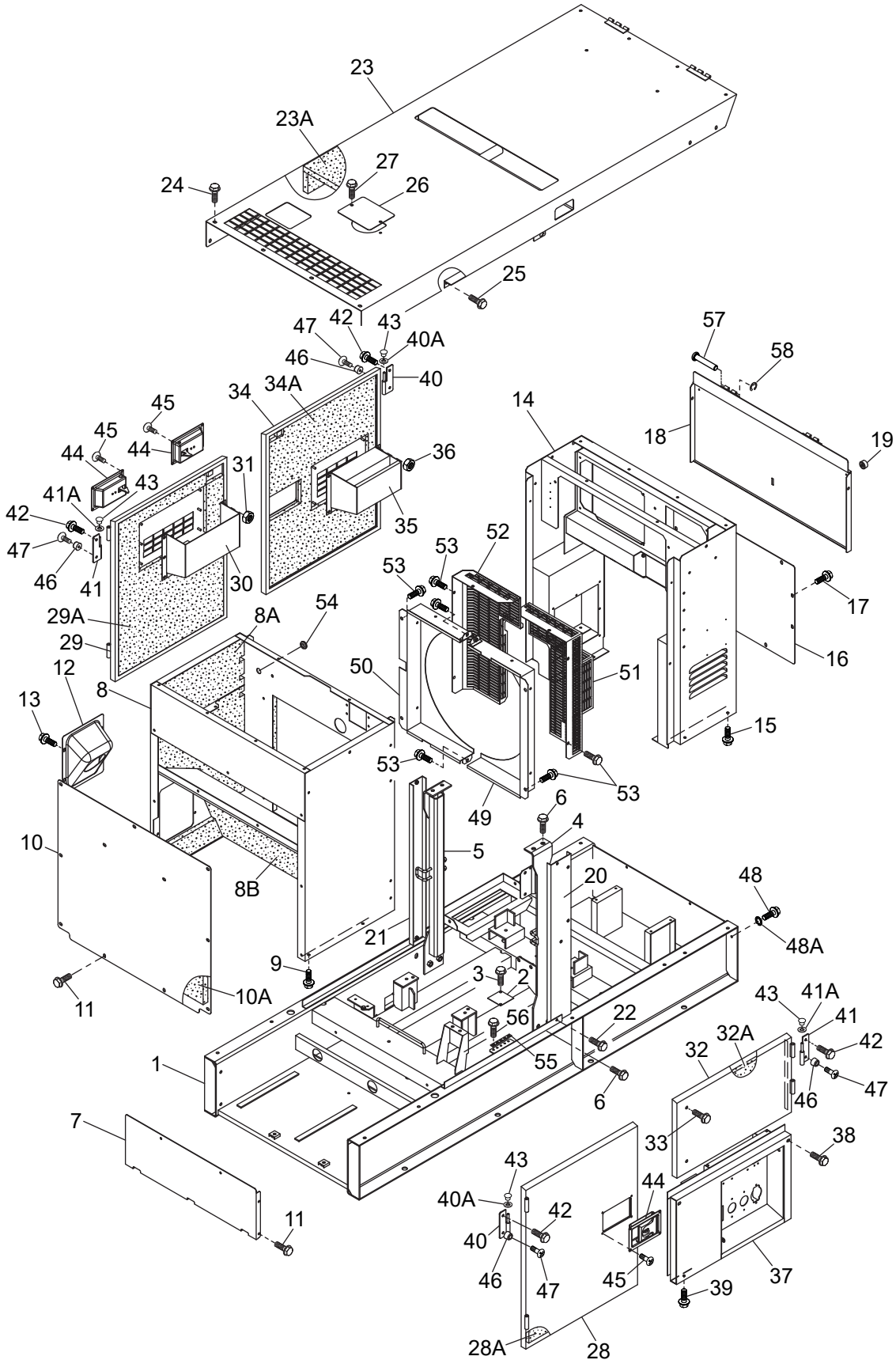

ENCLOSURE ASSY. (CONT'D.)

<u>NO.</u>	<u>PART NO.</u>	<u>PART NAME</u>	<u>QTY.</u>	<u>REMARKS</u>
34	D6454001803	SIDE DOOR.....	1.....	S/N 5895115 AND BELOW
34	D6454002403	SIDE DOOR.....	1.....	S/N 5895116 AND ABOVE
34A	D6494403104	LINING.....	1.....	S/N 5895115 AND BELOW
34A	D6494403114	LINING.....	1.....	S/N 5895116 AND ABOVE
35	D6454301204	DUCT	1	
36	0176060030	HEX. NUT	5.....	REPLACES P/N 0207006000
37	D6454200602	SPLASHER PANEL	1	
38	0016908055	HEX. HEAD BOLT	2	
39	011008020	HEX. HEAD BOLT.....	2.....	REPLACES P/N 0016908020
40	M9110100204	HINGE MALE (L)	4.....	REPLACES P/N 0845047104
40A	0845045004	WASHER	4	
41	M9110100304	HINGE MALE (R).....	4.....	REPLACES P/N 0845047204
41A	0845045004	WASHER	4	
42	011008020	HEX. HEAD BOLT.....	16.....	REPLACES P/N 0016908020
43	0845031504	CAP	8	
44	B9114000002	DOOR HANDLE ASSY.	3	
45	0021806015	MACHINE SCREW	12	
46	0601850097	STOPPER	4	
47	0027208025	MACHINE SCREW	4	
48	Y0345908020	HEX. HEAD BOLT	1	
48A	0040508000	TOOTHED WASHER	1	
49	D6311300303	FAN SHROUD	1	
50	D6311300203	FAN SHROUD	1	
51	D6311201003	FAN GUARD	1	
52	D6311200903	FAN GUARD	1	
53	011008020	HEX. HEAD BOLT.....	12.....	REPLACES P/N 0016908020
54	0601850239	GROMMET	1	
55	8511864601A	PLATE.....	1.....	REPLACES P/N 8511864604
56	0016906015	HEX. HEAD BOLT	4	
57	0810014704	PIN	2	
58	0080200004	SNAP RING	2	

RUBBER SEALS ASSY.

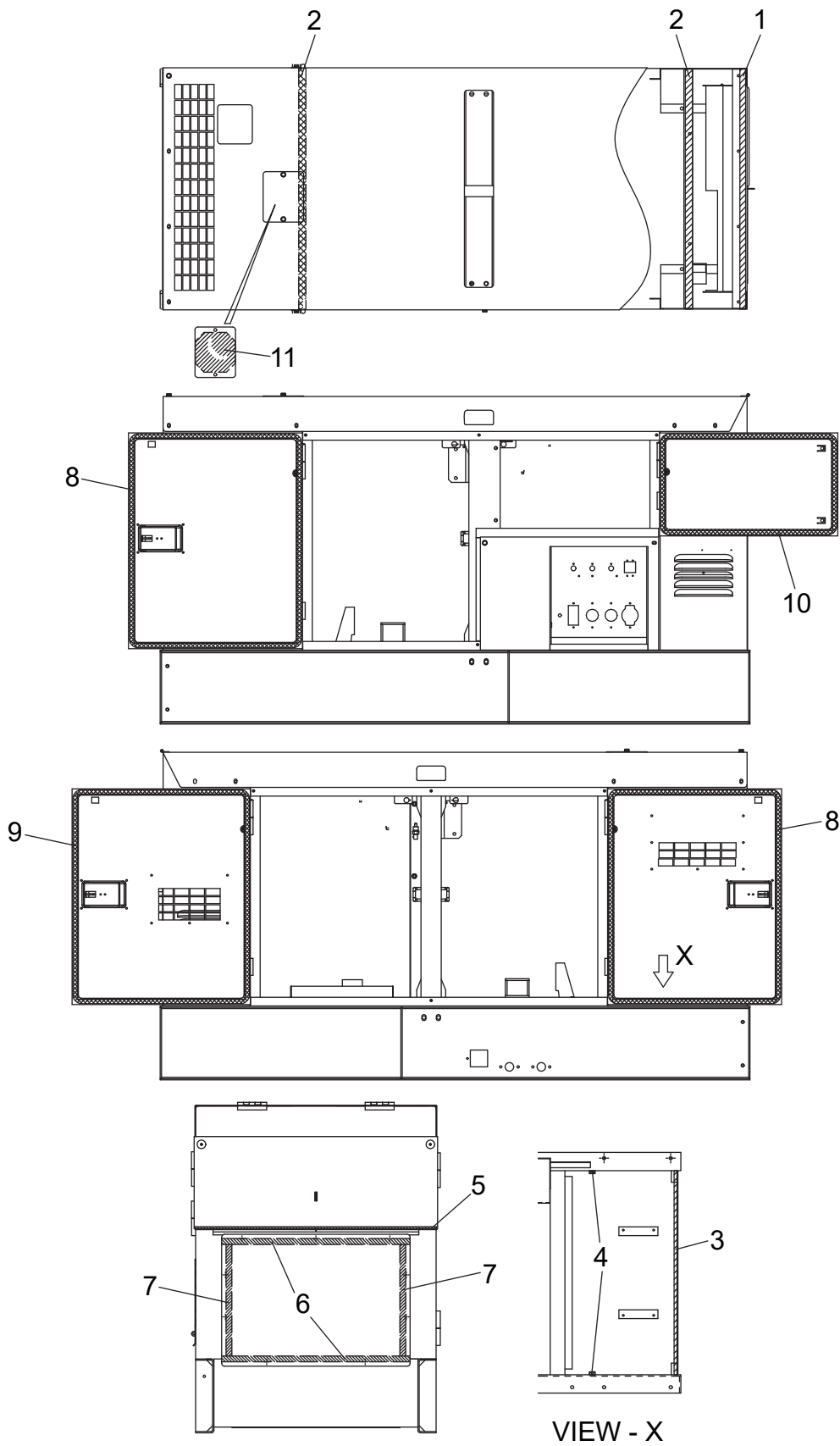

RUBBER SEALS ASSY.

<u>NO.</u>	<u>PART NO.</u>	<u>PART NAME</u>	<u>QTY.</u>	<u>REMARKS</u>
1	D6491400404	RUBBER SEAL	1	
2	Y0229200830	RUBBER SEAL	2	
3	D6491700104	RUBBER SEAL	1	
4	D6491700204	RUBBER SEAL	1	
5	Y0226900835	RUBBER SEAL	1	
6	Y0228400650	RUBBER SEAL	2	
7	Y0228400385	RUBBER SEAL	2	
8	Y0314202610	RUBBER SEAL	2	
9	Y0314202640	RUBBER SEAL	1	
10	Y0314201860	RUBBER SEAL	1	
11	D9311400504	RUBBER SEAL	1	

NAMEPLATE AND DECALS ASSY.

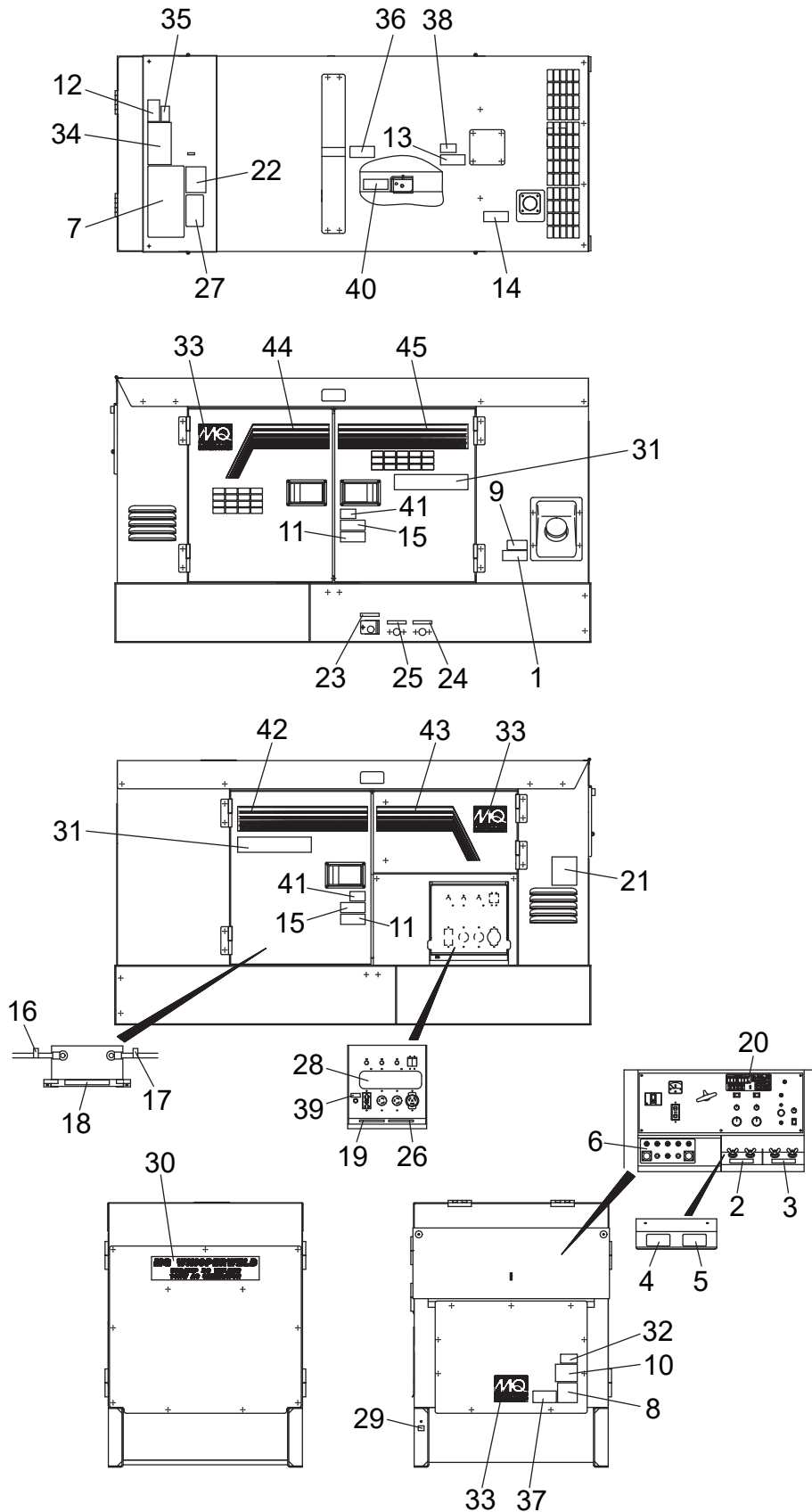

NAMEPLATE AND DECALS ASSY.

<u>NO.</u>	<u>PART NO.</u>	<u>PART NAME</u>	<u>QTY.</u>	<u>REMARKS</u>
1	B9504500004	DECAL; WARNING.....	1.....	B90450000
2	D5551001904	DECAL; A WELDING OUTPUT TERMINAL	1.....	D55100190
3	D5551002004	DECAL; B WELDING OUTPUT TERMINAL	1.....	D55100200
4	D5551002104	DECAL; A WELDING OUTPUT TERMINAL	1.....	D55100210
5	D5551002204	DECAL; B WELDING OUTPUT TERMINAL.....	1.....	D55100220
6	D6551009802	DECAL; FEEDER OUTPUT OPERATION.....	1.....	D65100980A
7	D6551009903	DECAL; OPERATION	1.....	D65100990
8	D9531100004	DECAL; WARNING EARTH GROUND.....	1.....	D93110000
9	B9504501214	DECAL; DIESEL FUEL	1.....	B90450121
10	A9504000014	DECAL; DANGER.....	1.....	A90400001
11	B9504000404	DECAL; WARNING MOVING PARTS	2.....	B90400040
12	0820610404	DECAL; WARNING.....	1.....	S-3627
13	B9504100104	DECAL; WARNING HOT COOLANT.....	1.....	B90410010
14	W8700611804	DECAL; WARNING DANGEROUS.....	1.....	S-4984
15	B9504000304	DECAL; WARNING HOT PARTS.....	2.....	B90400030
16	0800689404	DECAL; +	1.....	S-2090
17	0800689504	DECAL; -	1.....	S-2091
18	D6551009604	DECAL; CAUTION BATTERY	1	
19	8700611904	DECAL; DANGER, ELEC. SHK. HAZARD	1.....	S-4985
20	D2551000603	DECAL; OPERATION INDICATION	1	
21	D6531102504	DECAL; SPECIFICATION.....	1.....	D63110250
22	6390671104	DECAL; IMPORTANT CHECK DAILY.....	1.....	S-2377
23	1630645004	DECAL; OIL DRAIN	1.....	S-1403
24	1630647004	DECAL; WATER DRAIN	1.....	S-1404
25	7810680104	DECAL; FUEL DRAIN.....	1.....	S-3060
26	B9511100304	DECAL; WARNING.....	1.....	B91110030
27	D2551001004	DECAL; ERROR CODES	1.....	D25100100
28	D6551009503	DECAL; AC POWER OUTPUT.....	1.....	D65100950
29	0800628504	DECAL; GROUND	1.....	S-1123
30	D6561001002	DECAL; MQ WHISPERWELD	1.....	D66100100
31	D9511200803	DECAL; SMART STICK	2	
32	A9511101304	DECAL; WARNING PROPOSITION 65.....	1.....	A91110130
33	D3561000104	DECAL; MQ	3	
34	D9512100203	DECAL; CAUTIONS ON WELDING OPER.	1.....	D91210020
35	D6551010004	DECAL; CAUTION.....	1.....	D65101000
36	D6551010104	DECAL; MAX. CAPACITY OF LIFTING.....	1.....	D65101010
37	920214100	DECAL; WARNING START FIRES.....	1.....	REPLACES P/N M9504200004 M90420000
38	W7810680204	DECAL; COOLING WATER.....	1.....	S-3061
39	7670624004	DECAL; GROUND	1.....	S-3821
40	8700611524	DECAL; CAUTION OIL LEVEL GAUGE	1.....	S-4926B
41	1630610504	DECAL; CAUTION DOOR.....	2.....	S-1409
42	D6561100102	STRIPE.....	1.....	D66110010
43	D6561100202	STRIPE.....	1.....	D66110020
44	D6561100302	STRIPE.....	1.....	D66110030
45	D6561100402	STRIPE.....	1.....	D66110040

PARTS MANUAL

HERE'S HOW TO GET HELP

PLEASE HAVE THE MODEL AND SERIAL
NUMBER ON-HAND WHEN CALLING

UNITED STATES

Multiquip Inc.

(310) 537- 3700
6141 Katella Avenue Suite 200
Cypress, CA 90630
E-MAIL: mq@multiquip.com
WEBSITE: www.multiquip.com

CANADA

Multiquip

(450) 625-2244
4110 Industriel Boul.
Laval, Quebec, Canada H7L 6V3
E-MAIL: infocanada@multiquip.com

UNITED KINGDOM

Multiquip (UK) Limited Head Office

0161 339 2223
Unit 2, Northpoint Industrial Estate, Globe Lane,
Dukinfield, Cheshire SK16 4UJ
E-MAIL: sales@multiquip.co.uk

© COPYRIGHT 2024, MULTIQUIP INC.

Multiquip Inc, the MQ logo are registered trademarks of Multiquip Inc. and may not be used, reproduced, or altered without written permission. All other trademarks are the property of their respective owners and used with permission.

This manual MUST accompany the equipment at all times. This manual is considered a permanent part of the equipment and should remain with the unit if resold.

The information and specifications included in this publication were in effect at the time of approval for printing. Illustrations, descriptions, references and technical data contained in this manual are for guidance only and may not be considered as binding. Multiquip Inc. reserves the right to discontinue or change specifications, design or the information published in this publication at any time without notice and without incurring any obligations.

