

OPERATION MANUAL



MODEL G55H GASOLINE VIBRATOR (HONDA GX160K1QX2 GASOLINE ENGINE)

Revision #1 (07/08/21)

To find the latest revision of this publication or
associated parts manual, visit our website at:
www.multiquip.com



THIS MANUAL MUST ACCOMPANY THE EQUIPMENT AT ALL TIMES.



G-55H GASOLINE VIBRATOR

Proposition 65 Warning 2
Table Of Contents 3
Specifications 4
Safety Message Alert Symbols 5-6
Rules For Safe Operation 7-8
Operation and Safety Decals 9
General Information 10
Major Components 11
Engine Components 12
Inspection 13-14
Startup Procedures 15-16
Shutdown Procedures 16
Operation 17-18
Maintenance 19-20
Troubleshooting (Gasoline Engine) 21

NOTICE

Specifications are subject to change without notice.

TABLE 1. G55H SPECIFICATIONS

Vibrator Shaft Speed	10,600 RPMs @ 3600 Engine RPMs
Power Unit	
Dimensions (L x W x H)	24 x 20 x 18 in. (61 x 51 x 46 cm.)
Weight w/ Engine	77 Lbs. (35 Kg)

TABLE 2. ENGINE SPECIFICATIONS

TABLE 2. ENGINE SPECIFICATIONS		
Engine	Model	HONDA GX160K1QX2
	Type	4-stroke, Overhead valve, Single Cylinder
	Bore X Stroke	2.7 in. X 1.8 in. (68 mm x 45 mm)
	Displacement	9.9 cu. in. (163 cc)
	Max Output	5.4 bhp(4.0 kW, 5.5 PS) @ 3,600 R.P.M.
	Fuel Tank Capacity	Approx. 0.95 U.S. Gallons (3.6 Liters)
	Standard Idle Speed	1,400 +200/-150 R.P.M.
	Fuel	Unleaded Gasoline
	Lube Oil Capacity	0.63 U.S. Quarts (0.60 Liters)
	Speed Control Method	Centrifugal Fly-weight Type
	Starting Method	Recoil Start
Dimension (L x W x H)		12.0 x 14.3 X 13.2 in. (304 X 362 X 335 mm)
Dry Net Weight		33.1 lbs (15.0 Kg.)

SAFETY MESSAGE ALERT SYMBOLS

FOR YOUR SAFETY AND THE SAFETY OF OTHERS!

Safety precautions should be followed at all times when operating this equipment. Failure to read and understand the Safety Messages and Operating Instructions could result in injury to yourself and others.



NOTICE

This Owner's Manual has been developed to provide complete instructions for the safe and efficient operation of the **G-55H Gasoline Vibrator**. Refer to the engine manufacturers instructions for data relative to its safe operation.

Before using this vibrator, ensure that the operating individual has read and understands all instructions in this manual.

SAFETY MESSAGE ALERT SYMBOLS

The three (3) Safety Messages shown below will inform you about potential hazards that could injure you or others. The Safety Messages specifically address the level of exposure to the operator, and are preceded by one of three words: **DANGER**, **WARNING**, or **CAUTION**.

DANGER

You **WILL** be **KILLED** or **SERIOUSLY** injured if you **DO NOT** follow directions.

WARNING

You **CAN** be **KILLED** or **SERIOUSLY** injured if you **DO NOT** follow directions.

CAUTION

You **CAN** be **INJURED** if you **DO NOT** follow directions.

HAZARD SYMBOLS

Potential hazards associated with the operation of an **STOW G55H Gasoline Vibrator** will be referenced with Hazard Symbols which appear throughout this manual, and will be referenced in conjunction with Safety Message Alert Symbols.

WARNING Lethan Exhaust Gas Hazards

Engine exhaust gases contain poisonous carbon monoxide. This gas is colorless and odorless, and can cause death if inhaled. **NEVER** operate this equipment in a confined area or enclosed structure that does not provide ample free flow air.



WARNING Explosive Fuel Hazards

Gasoline is extremely flammable, and its vapors can cause an explosion if ignited. **DO NOT** start the engine near spilled fuel or combustible fluids.



DO NOT fill the fuel tank while the engine is running or hot. **DO NOT** overfill tank, since spilled fuel could ignite if it comes into contact with hot engine parts or sparks from the ignition system. Store fuel in approved containers, in well-ventilated areas and away from sparks and flames.

WARNING Burn Hazards

Engine components can generate extreme heat. To prevent burns, **DO NOT** touch these areas while the engine is running or immediately after operations. Never operate the engine with heat shields or heat guards removed.



WARNING Respiratory Hazards

ALWAYS wear approved *respiratory* protection when required.



SAFETY MESSAGE ALERT SYMBOLS



CAUTION

Rotating Parts Hazards

NEVER operate equipment with covers, or guards removed. Keep fingers, hands, hair and clothing away from all moving parts to prevent injury.



CAUTION

Equipment Damage Hazards

Other important messages are provided throughout this manual to help prevent damage to your equipment, other property, or the surrounding environment.



CAUTION

Accidental Starting Hazards

ALWAYS place the power source, circuit breakers or **ON/OFF** switch in the **OFF** position, when the generator is not in use, unless connected to transfer switch.



CAUTION

Eye and Hearing Hazards

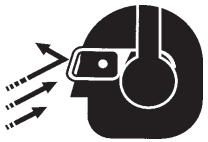

ALWAYS wear approved eye and hearing protection.

RULES FOR SAFE OPERATION

DANGER

Read this manual!

Failure to follow instructions in this manual may lead to serious injury or even death! This equipment is to be operated by trained and qualified personnel only! This equipment is for industrial use only.

The following safety guidelines should always be used when operating the G-55H Gasoline Vibrator:

GENERAL SAFETY

- **DO NOT** operate or service this equipment before reading this entire manual.
- This equipment should not be operated by persons under 18 years of age.
- **NEVER** operate this equipment without proper protective clothing, shatterproof glasses, steel-toed boots and other protective devices required by the job.



- **NEVER** operate this equipment when not feeling well due to fatigue, illness or taking medicine.
- **NEVER** operate this equipment under the influence of **drugs** or **alcohol**.



- **ALWAYS** wear proper respiratory (mask), hearing and eye protection equipment when operating the vibrator.
- **NEVER** place hands inside the drum while the blades are rotating.
- Whenever necessary, replace nameplate, operation and safety decals when they become difficult read.
- Manufacture does not assume responsibility for any accident due to equipment modifications.
- **NEVER** use accessories or attachments, which are not recommended by Multiquip for this equipment. Damage to the equipment and/or injury to user may result.

- **NEVER** touch the hot exhaust manifold, muffler or cylinder. Allow these parts to cool before servicing engine or vibrator.

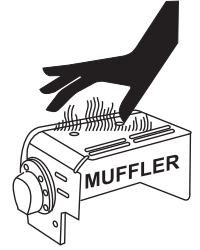

- **High Temperatures** – Allow the engine to cool before adding fuel or performing service and maintenance functions. Contact with **hot!** components can cause serious burns.

- The engine section of this vibrator requires an adequate free flow of cooling air. **NEVER** operate the vibrator in any enclosed or narrow area where free flow of the air is restricted. If the air flow is restricted it will cause serious damage to the vibrator or engine and may cause injury to people. Remember the vibrator's engine gives off **DEADLY** carbon monoxide gas.

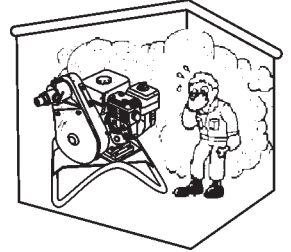

- **ALWAYS** refuel in a well-ventilated area, away from sparks and open flames.
- **ALWAYS** use extreme caution when working with **flammable** liquids. When refueling, **stop the engine** and allow it to cool. **DO NOT smoke** around or near the machine. Fire or explosion could result from fuel vapors, or if fuel is spilled on a hot engine.
- **NEVER** operate the equipment in an explosive atmosphere or near combustible materials. An explosion or fire could result causing severe **bodily harm or even death**.



- Topping-off to filler port is dangerous, as it tends to spill fuel.
- Stop the engine when leaving the vibrator unattended.
- Maintain this equipment in a safe operating condition at all times.
- **ALWAYS** check to make sure the cutting area is clear before starting the engine.
- **ALWAYS** clear the work area of any debris, tools, etc. that would constitute a hazard while the vibrator is in operation.

RULES FOR SAFE OPERATION

- **ALWAYS** stop the engine before servicing, adding fuel and oil.
- **NEVER** run engine without air filter. Severe engine may occur.
- **ALWAYS** service air cleaner frequently to prevent carburetor malfunction.
- **ALWAYS** be sure the operator is familiar with proper safety precautions and operations techniques before using.
- **ALWAYS** store equipment properly when it is not being used. Equipment should be stored in a clean, dry location out of the reach of children.
- **DO NOT** operate this equipment unless all guards and safety devices are attached and in place.
- **CAUTION** must be exercised while servicing this equipment. Rotating and moving parts can cause injury if contacted.
- Keep all *inexperienced* and *unauthorized* people away from the equipment at all times.
- Unauthorized equipment modifications will void all warranties.
- **NEVER** pour or spray water over the engine or electric motor.
- Test the **ON/OFF** switch for the gasoline engine before operating. The purpose of these switches is to shut down the engine of the vibrator.
- Refer to the **HONDA Engine Owner's Manual** for engine technical questions or information recommended by Multiquip for this equipment. Damage to the equipment and/or injury to user may result.

TRANSPORTING

- **ALWAYS** shutdown engine before transporting.
- Tighten fuel tank cap securely and close fuel cock to prevent fuel from spilling.
- **ALWAYS** use proper lifting techniques when using or moving the vibrator motor, flexible shaft or vibrator head assembly.

MAINTENANCE

- **NEVER** lubricate components or attempt service on a running vibrator.
- **ALWAYS** allow the vibrator a proper amount of time to cool before servicing.
- Keep the vibrator in proper running condition.
- Fix damage to the vibrator immediately and always replace broken parts.
- Dispose of hazardous waste properly. Examples of potentially hazardous waste are used motor oil, fuel and fuel filters.
- **DO NOT** use food or plastic containers to dispose of hazardous waste.

EMERGENCIES

- **ALWAYS** know the location of the nearest **fire extinguisher** and **first aid kit**.



- In emergencies **always** know the location of the nearest phone or **keep a phone on the job site**. Also know the phone numbers of the nearest **ambulance**, **doctor** and **fire department**. This information will be invaluable in the case of an emergency.



OPERATION AND SAFETY DECALS

Operation And Safety Decals

The MQ/STOW G-55H Gasoline Vibrator is equipped with a number of operation and safety decals (Figure 1). These decals are provided for operator safety and maintenance information. Should any of these decals become unreadable, replacements can be obtained from your dealer.



P/N 36521



P/N 11247 (ISO Black)



P/N 21302

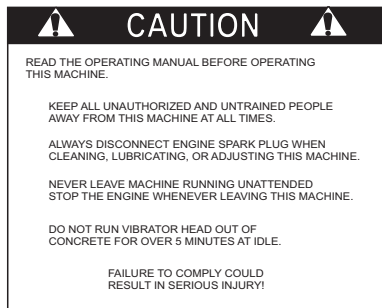

P/N 25883-001

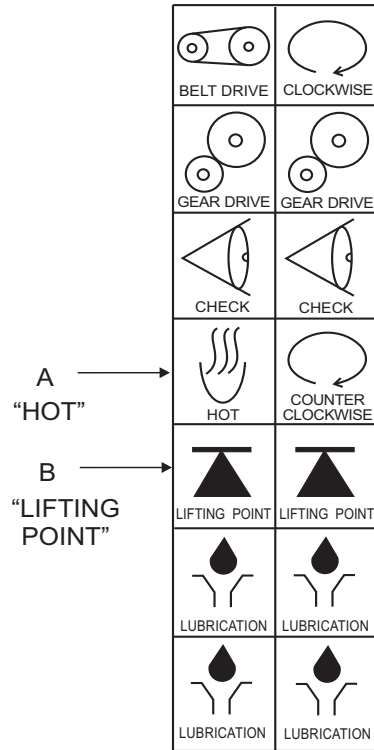

DECAL SHEET
INTL STDS ISO
P/N 11246



CONTACT PARTS
DEPARTMENT

Figure 1. Operation and Safety Decals

General Information

The G-55H Gasoline Vibrator employs a 5.5 HP Honda engine. It comes standard with a quick-disconnect coupling and an eccentric belt tensioner.

The G-55H power unit utilizes a sturdy frame which enables the engine to operate in a 360° rotation.

When operating the vibrator always wear rubber insulated gloves and boots. Safety glasses are also recommended.

Tips

- Keep the bending radius of the flexible hose to a minimum during use.
- Avoid starting the unit with the vibrator head immersed in the concrete mix. After the engine has started, immerse the vibrator head into concrete mix.
- Excessive wear to the vibrating head can result from misuse. **DO NOT** allow the head to vibrate against already hardened concrete or steel used in reinforcement.
- **NEVER** drop or knock the vibrator head against any hard objects. This will prevent any damage the eccentric or bearings contain within the head.
- **ALWAYS** rinse or wipe off any wet concrete before it dries or hardens on any part of the unit (engine, shaft, or head).

Before operating this gasoline powered vibrator, the operator must **read** and **understand** the contents of the operation manual. Failure to read this manual could result in severe bodily harm and damage to the equipment.



Theory Of Concrete Vibration

The G-55H Vibrator is designed for the **compaction** of concrete by removal of air pockets and voids.

The purpose of vibration is to set the particles in the fresh concrete in motion, thereby reducing the friction between the particles and giving the mixture the mobile quality of a thick fluid so that gravity and the displacement of entrapped air will cause it to settle easily into place.

By consolidating the concrete quickly, "stiffer" or "drier" mixes can be poured than would otherwise be possible. It has been proven that (up to a point) the drier the concrete, (that is, the less water in it), the better the quality throughout and the greater the strength. Drier mixes also make the concrete more water tight, increase resistance to weathering, and create a better bond between concrete and reinforcement.

Because vibration causes much of the entrapped air in the concrete to rise to the surface, honeycombing is prevented. Also, vibration eliminates most of the air pockets between the concrete and the vertical forms.

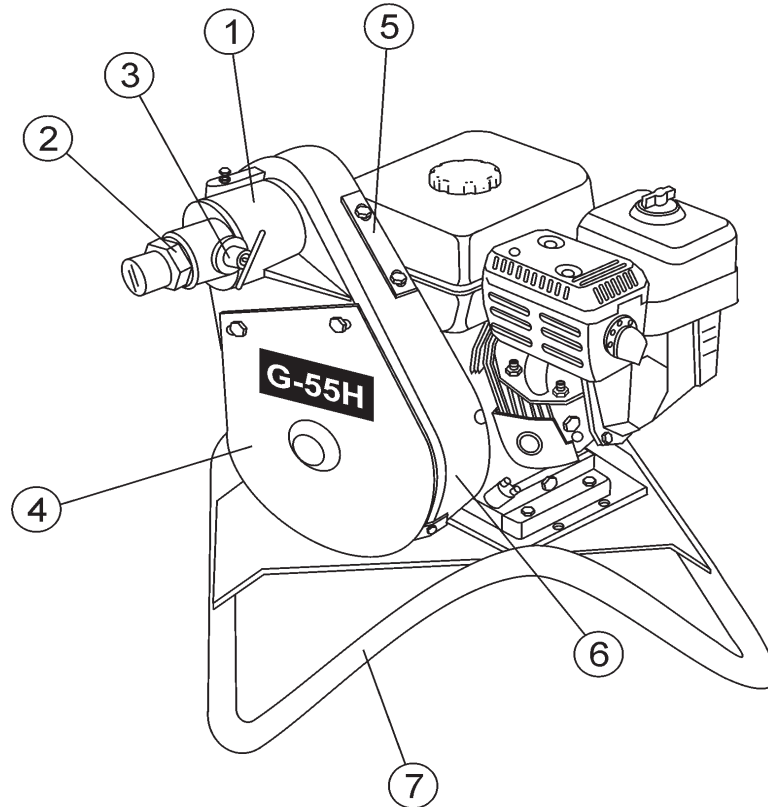

Figure 2. G-55H Gasoline Vibrator Components



Figure 2 shows the location of the components and general maintenance parts. The function of each component is described below:

1. **Eccentric Bell End** – Supports the spindle shaft and upper pulley which drives the vibration function of the G-55H. The flexible shaft and quick disconnect are inserted into the open end of the Eccentric Bell.
2. **328V Quick Disconnect** – Connect the flexible shaft to the quick disconnect and insert into the eccentric bell. This allows for rapid removal of the flexible shaft end from the vibrator base.
3. **Quick Disconnect Lock Pin** – Pull up on the lock pin and pull the flexible shaft out to release the quick disconnect from the eccentric bell. To insert a flexible shaft, pull up on the lock pin and insert the quick disconnect fitting. Release the pin and turn the fitting until the lock pin drops into one of the holes on the fitting end.
4. **Front Belt Guard** – Attaches to the V-belt housing and prevents access to the pulleys or V-belts while the vibrator is running. **DO NOT** operate the vibrator with this cover removed.
5. **Rear Belt Guard** – Attaches to the V-belt housing and prevents access to the pulleys or V-belts while the vibrator is running. **DO NOT** operate the vibrator with this cover removed.
6. **V-belt Housing** – Encloses the pulley's and v-belts. Access is provided through openings in the front and rear of the housing.
7. **Vibrator Support Stand** – Allows the vibrator base to sit upright. A pivot mechanism allows the base to freely pivot in a complete 360 degree circle for operators convenience.

5.5 HP Honda Gasoline Engine

The engine (Figure 3) must be checked for proper lubrication and filled with fuel prior to operation. Refer to the manufacturer's engine manual for instructions & details of operation and servicing. The engine shown above is a **HONDA** engine. Operation for other types of engines may vary.

1. **Fuel Filler Cap** – Remove this cap to add unleaded gasoline to the fuel tank. Make sure cap is tightened securely. **DO NOT** over fill.

 DANGER	Explosive Fuel Hazard
<p>Adding fuel to the tank should be done only when the engine is stopped and has had an opportunity to cool down. In the event of a fuel spill, DO NOT attempt to start the engine until the fuel residue has been completely wiped up, and the area surrounding the engine is dry.</p>	
	

2. **Throttle Lever** – Used to adjust engine RPM speed (lever advanced forward **SLOW**, lever back toward operator **FAST**).
3. **Engine ON/OFF Switch** – **ON** position permits engine starting, **OFF** position stops engine operation.
4. **Recoil Starter (pull rope)** – Manual-starting method. Pull the starter grip until resistance is felt, then pull briskly and smoothly.
5. **Fuel Valve Lever** – **OPEN** to let fuel flow, **CLOSE** to stop the flow of fuel.
6. **Choke Lever** – Used in the starting of a cold engine, or in cold weather conditions. The choke enriches the fuel mixture.
7. **Air Cleaner** – Prevents dirt and other debris from entering the fuel system. Remove wing-nut on top of air filter cannister to gain access to filter element.

NOTICE

Operating the engine without an air filter, with a damaged air filter, or a filter in need of replacement will allow dirt to enter the engine, causing rapid engine wear.

8. **Spark Plug** – Provides spark to the ignition system. Clean spark plug once a week.

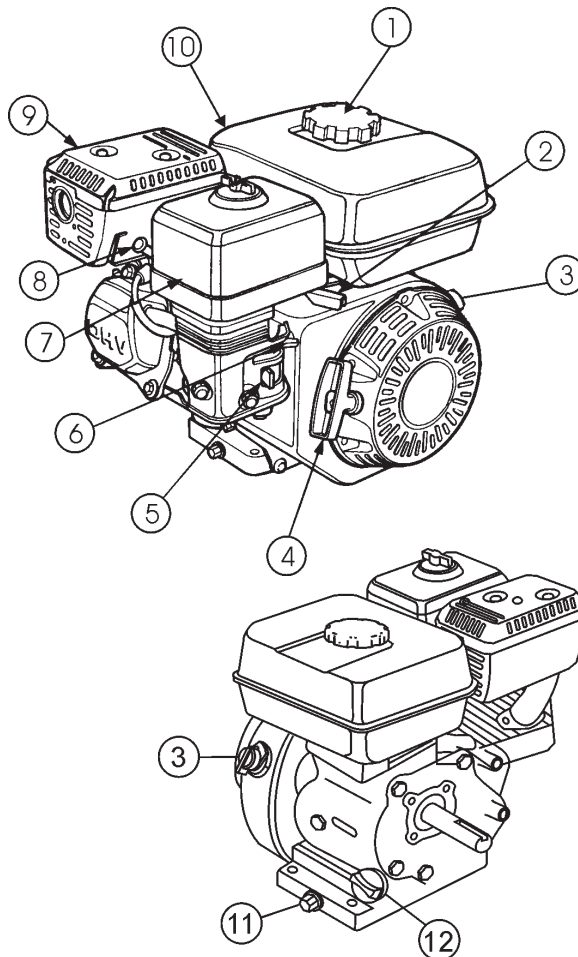



Figure 3. Honda GX160T1QX2 Engine Components

9. **Muffler** – Used to reduce noise and emissions.

 WARNING	Burn Hazard
<p>Engine components can generate extreme heat. To prevent burns, DO NOT touch these areas while the engine is running or immediately after operating. NEVER operate the engine with the muffler removed.</p>	
	

10. **Fuel Tank** – Holds unleaded gasoline. For additional information refer to engine owner's manual.
11. **Oil Drain Plug** – Remove this plug to remove oil from the engine's crankcase.
12. **Dipstick/Oil Filler Cap** – Remove this cap to determine if the engine oil is low. Add oil through this filler port as recommended in Table 3.

CAUTION

Inspection & Maintenance Safety

NEVER place hands or feet inside the belt guard cover while the engine is running. **ALWAYS** shut the engine down before performing any kind of maintenance service on the unit.



CAUTION

Eyesight and Hearing Protection

ALWAYS wear approved eye and hearing protection before inspecting, operating or servicing the vibrator.

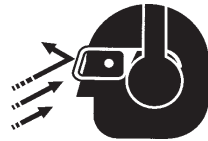

Before Starting

Before starting and operating the G55H Gasoline Vibrator, perform the following:

- Read safety instructions at the beginning of manual.
- Clean the vibrator, removing dirt and dust, particularly the engine cooling air inlet, carburetor and air cleaner.
- Check the air filter for dirt and dust. If air filter is dirty, replace air filter with a new one as required.
- Check carburetor for external dirt and dust. Clean with dry compressed air.
- Check fastening nuts and bolts for tightness.
- Check the engine oil level of the engine.
- Check the fuel level of the engine.
- Check the tension and condition of the vibrator power unit's V-belts.

Engine Oil Check

1. To check the engine oil level, place the vibrator on secure level ground with the engine stopped.
2. Remove the filler dipstick from the engine oil filler hole (Figure 4) and wipe clean.

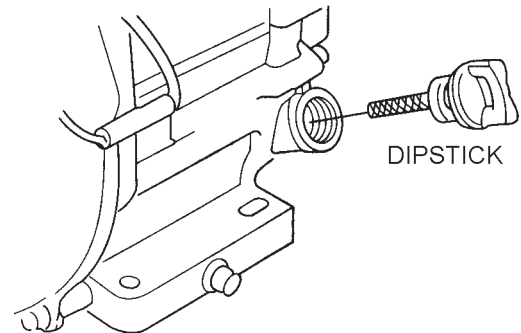

Figure 4. Engine Oil Dipstick (Removal)

3. Insert and remove the dipstick without screwing it into the filler neck. Check the oil level shown on the dipstick.
4. If the oil level is low (Figure 5), fill to the edge of the oil filler hole with the recommended oil type (Table 3). Maximum oil capacity is 0.63 quarts (.60 liters).

NOTICE

Reference manufacturer engine manual for specific servicing instructions.

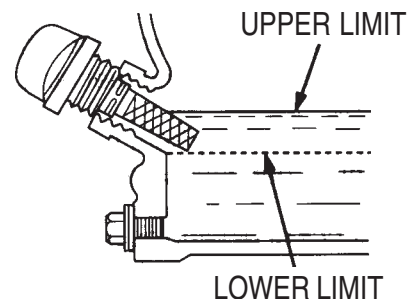

Figure 5. Engine Oil Dipstick (Oil Level)

Table 3. Oil Type

Season	Temperature	Oil Type
Summer	25°C or Higher	SAE 10W-30
Spring/Fall	25°C~10°C	SAE 10W-30/20
Winter	0°C or Lower	SAE 10W-10

**WARNING****Explosive Fuel Hazards**

Gasoline is extremely flammable, and its vapors can cause an explosion if ignited. **DO NOT** start the engine near spilled fuel or combustible fluids.



DO NOT fill the fuel tank while the engine is running or hot. **DO NOT** overfill tank, since spilled fuel could ignite if it comes into contact with hot engine parts or sparks from the ignition system. Store fuel in approved containers, in well-ventilated areas and away from sparks and flames.

1. Remove the gasoline cap located on top of fuel tank.
2. Visually inspect to see if fuel level is low. If fuel is low, replenish with unleaded fuel.
3. When refueling, be sure to use a strainer for filtration. **DO NOT** top-off fuel. Wipe up any spilled fuel.

V-Belt Check

A worn or damaged V-belt can adversely affect the performance of the vibrator.

1. Unscrew the bolts securing the front belt guard to the belt housing
2. Inspect the belts for defects or wear.
3. If a V-belt is defective or worn, replace the V-belt as outlined in the maintenance section of this manual.

Moving the Vibrator

Even though the vibrator is lightweight, always use two people when lifting the vibrator or moving the unit around the jobsite.

START-UP PROCEDURES

This section is intended to assist the operator with initial start-up. It is extremely important that this section be read carefully before attempting to use the vibrator in the field.



DO NOT use your vibrator until this section is thoroughly understood.

WARNING

General Safety

Failure to understand the operation of this vibrator could result in **severe damage** to the vibrator or **personal injury**.

See Figures 2 and 3 for the location of any control referenced in this manual.

CAUTION

Respiratory Hazard



NEVER operate the vibrator in a confined area or enclosed area structure that does not provide ample **free flow of air**.

Starting the Engine

1. Place the engine **fuel valve lever** (Figure 6) to the **ON** position.

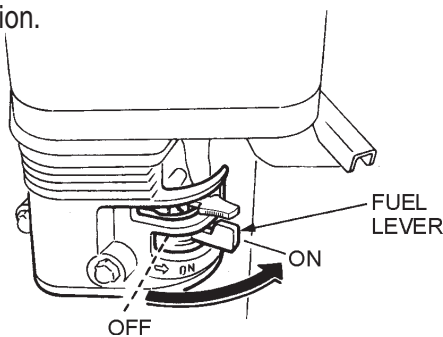

Figure 6. Engine Fuel Valve Lever

2. Place the engine **throttle lever** (Figure 7) to the **IDLE** or **SLOW** position.

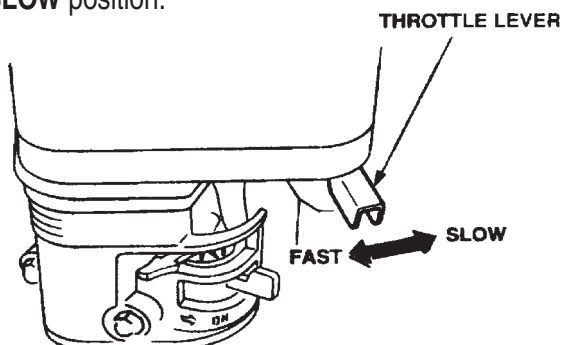

Figure 7. Throttle Lever

3. Place the engine **choke lever** (Figure 8) in the **CLOSED** position if starting a **cold engine**. Place the **choke lever** in the **OPEN** position if starting a **warm engine** or the **temperature is warm**.

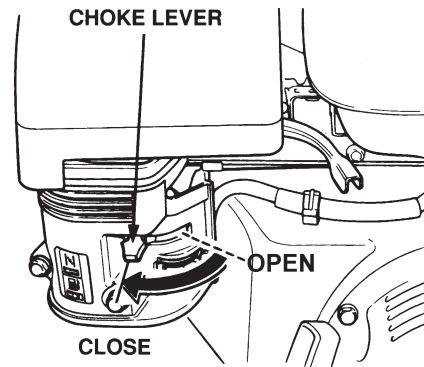

Figure 8. Engine Choke Lever

5. Place the engine **ON/OFF switch** (Figure 9) in the **ON** position.

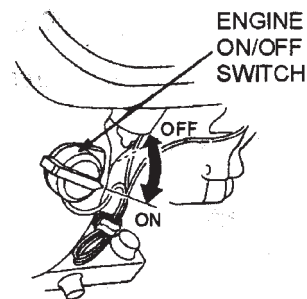

Figure 9. Engine ON/OFF Switch

6. Grasp the **recoil starter grip** (Figure 10) and slowly pull it out. The resistance becomes the hardest at a certain position, corresponding to the compression point. Pull the starter grip briskly and smoothly for starting.

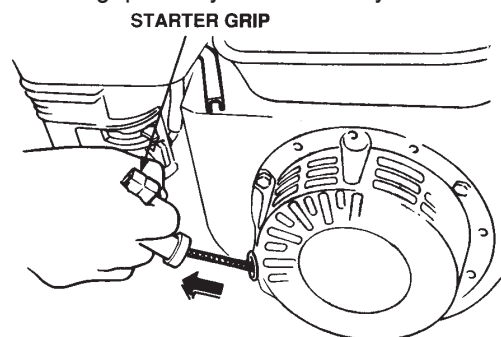

Figure 10. Starter Grip

START-UP/SHUTDOWN PROCEDURES

7. If the engine has started, slowly return the choke lever (Figure 6) to the **OPEN** position. If the engine has not started repeat steps 1 through 6.
8. Before the vibrator is placed into operation, immerse the vibrator head into the concrete and run the engine for several minutes. Check for fuel leaks, and noises that would associate with a loose V-belt cover or component.

CAUTION

Vibrator Head Overheating Hazard

The vibrator head is cooled by the concrete. Operation of the vibrator head in air longer than 2 minutes will cause overheating of the bearings which result in premature head failure.

9. To begin use, move the throttle lever (Figure 6) toward the **FAST** position.

Stopping The Engine

1. Move the throttle lever to the **IDLE** or **SLOW** position (Figure 11) and run the engine for three minutes at low speed.
2. After the engine cools, turn the engine **start/stop switch** to the **OFF** position (Figure 11).

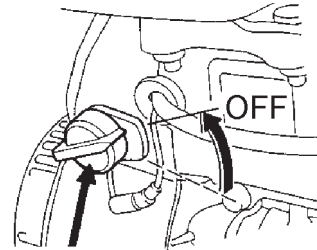

ENGINE
SWITCH

Figure 11. Engine ON/OFF Switch (OFF Position)

3. Close the **fuel shut-off valve** (Figure 12) by moving the fuel valve lever to the **OFF** position.

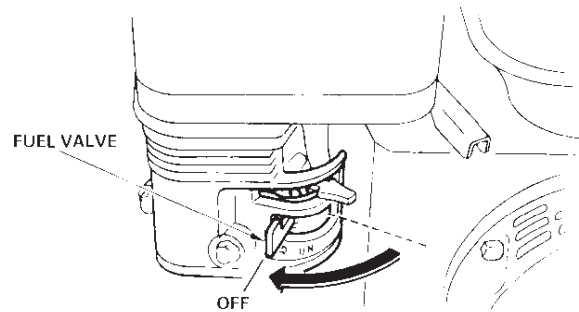

Figure 12. Fuel Valve Lever (OFF Position)

Operation

Read all the safety instructions carefully. Safety instructions will be found throughout this manual and on the vibrator motor. Keep all safety information available, accessible, and in good, readable condition.

- Make certain that the flexible shaft is properly attached to the motor and the head to the flexible shaft.
- Use the flexible shaft in as straight a position as possible.
- **Do not** bend the flexible shaft sharply at any point. Sharp bends may cause a permanent kink, requiring early replacement of the flexible shaft.

Equipment Combination Information

The following Equipment Combination Chart shows all of the recommended connections between the gasoline vibrator and the vibrator head.

TABLE 5. EQUIPMENT COMBINATIONS			
COUPLING	SHAFT	HEAD	MAX SHAFT LENGTH
382V Q.D	382V	1400 vib.	28 ft. (132.3 cm)
		1700 vib.	
		2100 vib.	21 ft. (99.2 cm)

! WARNING	Equipment Hazard
Using head attachments not listed above may create a hazardous condition when using the vibrator.	

The G55H Gasoline Vibrator, flexible shafting, and head are shipped from the factory ready for assembly. Follow the instructions listed below when connecting these parts before using the gasoline vibrator.

Connecting the 382V Flexible Shaft

1. Connect the 382V Flexible Shaft to the Quick Disconnect coupling (Figure 13).
2. Pull **UP** on the lock pin and slide the shaft and quick disconnect assembly into the eccentric end bell and release the lock pin.
3. Twist the shaft assembly to make sure that the lock pin is seated in one of the 3 tapered holes on the quick disconnect coupling.

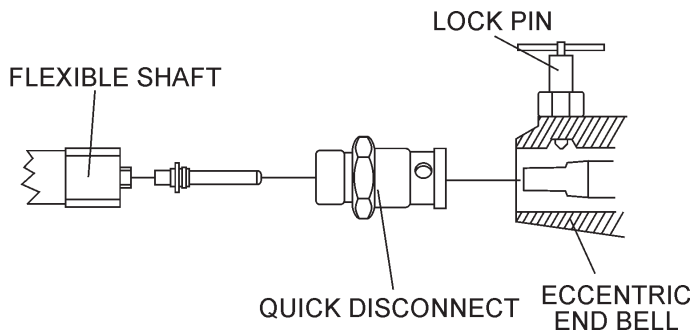

Figure 13. Couplings

Connecting the vibrator head to the flexible shaft

1. Clean the mating parts threads with Loctite Primer "T".
2. Allow to dry several minutes before applying a ring of Loctite No.271 to the middle of the casing threads.
3. Screw the head tightly to the flexible shaft casing and wait for 1 hour before using. The threads are left hand, turn counter-clockwise to tighten. An equivalent brand of anaerobic sealant may be used.

1. Start the engine as previously described and proceed to insert the vibrator head into the concrete.
2. The concrete is normally placed into the forms in layers about 12 to 18 inches thick in a manner which forms a fairly level surface. The vibrator head is inserted vertically into the top of the pile.
3. When the surface has become fairly level, the vibrator head then should be immersed and generally moved in the pattern shown in (Figure 14).

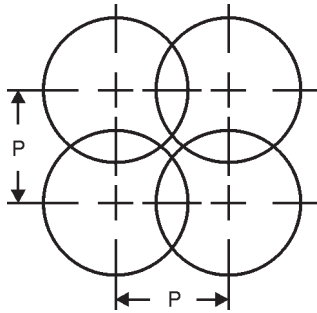

Figure 14. Compaction Coverage with 50% Radial Overlap

Use the flexible shaft in as straight a position as possible and do not bend the flexible shaft sharply at any point. Sharp bends may cause a permanent kink, requiring early replacement of the flexible shaft.

CAUTION

Shaft Overload Hazard

If the shaft begins to helix (buckle) excessively during operation, stop and investigate. This is an indication of an overload condition.

CAUTION

Vibrator Head Overheating Hazard

The vibrator head is cooled by the concrete. Operation of the vibrator head in air longer than 2 minutes will cause overheating of the bearings which result in premature head failure.

TABLE 4. HEAD AND P-DIMENSIONS

HEAD	1400	1700	2100
P-DIMENSION	8 in. (31.4 mm)	12 in. (47.2 mm.)	14 in. (55.1 mm)

- Immerse the head for 5 to 10 seconds, (until air stops rising), and then withdraw it slowly to let the concrete fill the void left by the vibrator head.
- The vibrator head should be completely below the surface when vibrating to keep the head cool.
- When vibrating a thin horizontal slab, the vibrator head can be used in a horizontal position.

NOTICE

DO NOT insert the vibrator head into the side of the pile to make the concrete flow as this practice can cause segregation of the aggregate from the mortar.

Maintenance Instructions

To receive trouble-free service from your STOW G55H gasoline vibrator, follow these instructions, as well as the instructions contained in the engine operating manual, flexible shaft operations manual and the vibrator head operations manual.

The 382V flexible shafting requires cleaning and lubrication every 100 hours of operation. Refer to the flexible shaft operation and parts manual for maintenance instructions.

Vibrator heads should be inspected and relubricated every 100 hours of operation. Refer to the vibrator head operation and parts manual for maintenance instructions.

NOTICE

Heat should be used to break down the loctite while you unthread the head from the shaft. This will prevent possible damage to the threads from the loctite.

WARNING

Disabling the Engine for Maintenance

Whenever assembling, lubricating, or adjusting any part of the gasoline vibrator make certain to stop the engine, disconnect the spark plug wire and secure it away from the spark plug.

Daily

- Thoroughly remove dirt and oil from the engine and control area. Clean or replace the air cleaner elements as necessary. Check and retighten all fasteners as necessary. Check the gearbox for oil leaks. Repair or replace as needed.

Weekly

- Remove the fuel filter cap and clean the inside of the fuel tank.
- Remove or clean the filter at the bottom of the tank.

- Remove and clean the spark plug (Figure 24), then adjust the spark gap to 0.024 ~0.028 inch (0.6~0.7 mm). This unit has electronic ignition, which requires no adjustments.

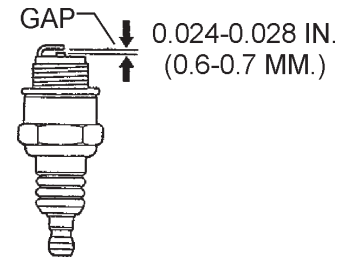

Figure 15. Spark Plug Gap

Engine Oil

- Drain the engine oil when the oil is **warm** as shown in Figure 25.
- Remove the oil drain bolt and sealing washer and allow the oil to drain into a suitable container.
- Replace engine oil with recommended type oil as listed in Table 3. For engine oil capacity, see Table 2 (engine specifications). **DO NOT** overfill.
- Install drain bolt with sealing washer and tighten securely.

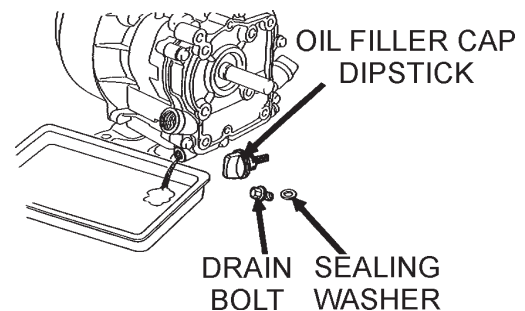

Figure 16. Engine Oil (Draining)

NOTICE

Dispose of used oil properly. **DO NOT** pour used oil on the ground, down a drain, or throw in the trash.

Used oil can generally be taken to your local recycling center or service station for reclamation. Follow all required environmental rules and regulations required in your area concerning the disposal of hazardous waste such as used oil and oil filters.

G55H GASOLINE VIBRATOR — MAINTENANCE

Engine Air Cleaner

1. Remove the air cleaner cover and foam filter element as shown in Figure 26.
2. Tap the paper filter element (Figure 26) several times on a hard surface to remove dirt, or blow compressed air [not exceeding 30 psi (207 kPa, 2.1 kgf/cm²)] through the filter element from the air cleaner case side. **NEVER** brush off dirt. Brushing will force dirt into the fibers. Replace the paper filter element if it is excessively dirty.
3. Clean foam element in warm, soapy water or nonflammable solvent. Rinse and dry thoroughly. Dip the element in clean engine oil and completely squeeze out the excess oil from the element before installing.



DANGER

Explosive Hazard

DO NOT use gasoline as a cleaning solvent to avoid creating the risk of fire or an explosion.

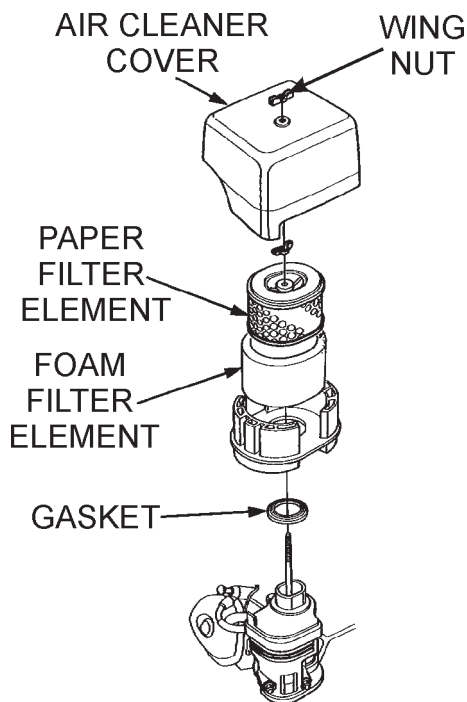

Figure 17. Engine Air Cleaner

V-Belt Tension

The belt can be tightened by rotating the eccentric countershaft assembly clockwise. When the belts are properly tensioned, they should deflect approximately 5 to 10mm when 5-10 pounds of force is applied centrally between the pulleys. Lock the countershaft in place with the locking screw and wing nut.

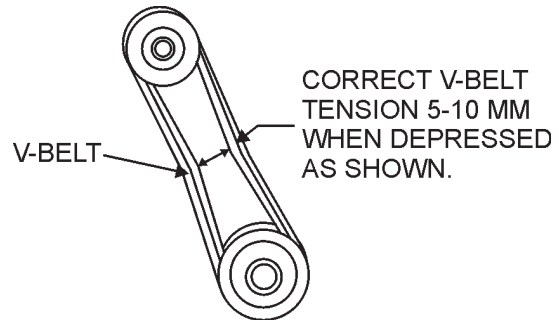

Figure 18. V-Belt Tension

Lubrication

Quick Disconnect Lock

A small amount of any lightweight oil should be used on the locking mechanism to help keep concrete from sticking and also to lubricate the locking pin and spring.

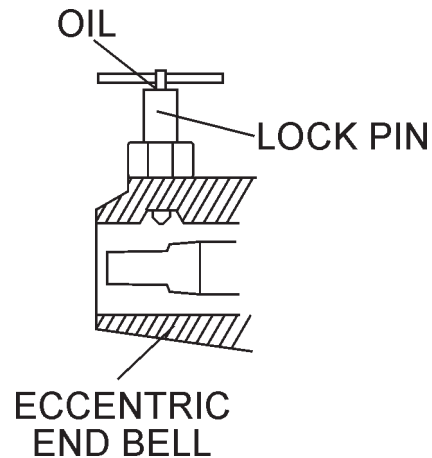

Figure 19. Quick Disconnect Lock

Pivot Assembly

Grease with a pressure gun as required.

G55H GASOLINE VIBRATOR — TROUBLESHOOTING (ENGINE)

TABLE 5. TROUBLESHOOTING (ENGINE)

SYMPTOM	POSSIBLE CAUSE	SOLUTION
Difficult to start, "fuel is available, but no SPARK at spark plug".	Spark plug bridging?	Check gap, insulation or replace spark plug.
	Carbon deposit on spark plug?	Clean or replace spark plug.
	Short circuit due to deficient spark plug insulation?	Check spark plug insulation, replace if worn.
	Improper spark plug gap?	Set to proper gap.
	Ignition coil defective?	Replace ignition coil.
Difficult to start, "fuel is available, and SPARK is present at the spark plug".	ON/OFF switch is shorted?	Check switch wiring, replace switch.
	Improper spark gap, points dirty?	Set correct spark gap and clean points.
	Condenser insulation worn or short circuiting?	Replace condenser.
	Spark plug wire broken or short circuiting?	Replace defective spark plug wiring.
Difficult to start, "fuel is available, spark is present and compression is normal".	Wrong fuel type?	Flush fuel system, and replace with correct type of fuel.
	Water or dust in fuel system?	Flush fuel system.
	Air cleaner dirty?	Replace air cleaner.
	Choke Open?	Close Choke.
Difficult to start, "fuel is available, spark is present and compression is low".	Suction/exhaust valve stuck or protruded?	Re-seat valves.
	Piston ring and/or cylinder worn?	Replace piston rings and/or piston.
	Cylinder head and/or spark plug not tightened properly?	Torque cylinder head bolts and spark plug.
	Head gasket and/or spark plug gasket damaged?	Replace head and/or spark plug gaskets.
No fuel present at the carburetor.	Fuel not available in fuel tank (tank empty)?	Fill with correct type of fuel.
	Fuel filter clogged?	Replace fuel filter.
	Fuel tank cap breather hole clogged?	Clean or replace fuel tank cap.
	Air in fuel line?	Bleed fuel line.

OPERATION MANUAL

HERE'S HOW TO GET HELP

PLEASE HAVE THE MODEL AND SERIAL
NUMBER ON-HAND WHEN CALLING

UNITED STATES

Multiquip Inc.

(310) 537- 3700
6141 Katella Avenue Suite 200
Cypress, CA 90630
E-MAIL: mq@multiquip.com
WEBSITE: www.multiquip.com

CANADA

Multiquip

(450) 625-2244
4110 Industriel Boul.
Laval, Quebec, Canada H7L 6V3
E-MAIL: infocanada@multiquip.com

UNITED KINGDOM

Multiquip (UK) Limited Head Office

0161 339 2223
Unit 2, Northpoint Industrial Estate,
Globe Lane,
Dukinfield, Cheshire SK16 4UJ
E-MAIL: sales@multiquip.co.uk

© COPYRIGHT 2021, MULTIQUIP INC.

Multiquip Inc, the MQ logo and the Mayco logo are registered trademarks of Multiquip Inc. and may not be used, reproduced, or altered without written permission. All other trademarks are the property of their respective owners and used with permission.

This manual MUST accompany the equipment at all times. This manual is considered a permanent part of the equipment and should remain with the unit if resold.

The information and specifications included in this publication were in effect at the time of approval for printing. Illustrations, descriptions, references and technical data contained in this manual are for guidance only and may not be considered as binding. Multiquip Inc. reserves the right to discontinue or change specifications, design or the information published in this publication at any time without notice and without incurring any obligations.

