

# OPERATION AND PARTS MANUAL



**MULTIQUIP®**

**GloBug SERIES**

**MODELS:**

**GB12BW**

*SERIAL NO. G2700001 AND ABOVE*

**GB12BS**

*SERIAL NO. G2800001 AND ABOVE*

**GB12BP**

*SERIAL NO. G2900001 AND ABOVE*

Revision #1 (10/04/19)



To find the latest revision of this publication, visit our website at:  
[www.multiquip.com](http://www.multiquip.com)



**THIS MANUAL MUST ACCOMPANY THE EQUIPMENT AT ALL TIMES.**

# Certificate



Certificate no.

CA 72131710 01

**License Holder:**

LIGHT BOY CO., LTD.  
2-6-14 Kurigi, Asao  
KAWASAKI, KANAGAWA 215-0033  
JAPAN

**Manufacturing Plant:**

LIGHT BOY CO., LTD.  
2-6-14 Kurigi, Asao  
KAWASAKI, KANAGAWA 215-0033  
JAPAN

Test report no.: USA-SS 17032848 001

Client Reference: Satomi Kugimiya

Tested to: CAN/CSA-C22.2 No. 9.0-96 (R2011)  
CAN/CSA-C22.2 No. 74-96+GI1 (R2010)

Certified Product: Portable HID luminaire, Globug Series

License Fee - Units

Model Designation: 1) GB12BW, GB12BS, GB12BP,  
2) GBW, GBS, GBC, GBP

7

Rated Voltage: AC 120V, 60Hz  
Rated Power: 1) 430W 2) 1030W

Appendix: 1, 1-9

7

Licensed Test mark:



Date of Issue  
(day/mo/yr)  
07/06/2013

TUV Rheinland of North America, Inc., 12 Commerce Road, Newtown, CT 06470, Tel (203) 426-0888 Fax (203) 426-4009

# TABLE OF CONTENTS

## GB12BW/BS/BP Lighting System

Table of Contents.....	3
Safety Information .....	4–7
Specifications .....	8
Dimensions (GB12BW) .....	9
Dimensions (GB12BS) .....	10
Dimensions (GB12BP) .....	11
Footcandle Plot.....	12
General Information.....	13
Components .....	14–15
Setup (GB12BW).....	16–18
Operation (GB12BW) .....	19–21
Setup (GB12BS).....	22–23
Operation (GB12BS) .....	24
Maintenance .....	25–29
Wiring Diagram.....	30
Troubleshooting .....	31
Explanation of Code in Remarks Column.....	32
Suggested Spare Parts .....	33

## Component Drawings

Nameplate and Decals (GB12BW).....	34–35
Nameplate and Decals (GB12BS).....	36–37
Nameplate and Decals (GB12BP).....	38–39
Mast/Tripod Assembly .....	40–41
Fan Blower/Lamp Assembly .....	42–43
Balloon/Lamp Guard Assembly .....	44–45
Offset Pole Assembly (GB12BS).....	46–47

### **NOTICE**

Specifications and part numbers are subject to change without notice.

# SAFETY INFORMATION

Do not operate or service the equipment before reading the entire manual. Safety precautions should be followed at all times when operating this equipment. Failure to read and understand the safety messages and operating instructions could result in injury to yourself and others.



## SAFETY MESSAGES

The four safety messages shown below will inform you about potential hazards that could injure you or others. The safety messages specifically address the level of exposure to the operator and are preceded by one of four words: **DANGER**, **WARNING**, **CAUTION** or **NOTICE**.

## SAFETY SYMBOLS

 **DANGER**

Indicates a hazardous situation which, if not avoided, **WILL** result in **DEATH** or **SERIOUS INJURY**.

 **WARNING**

Indicates a hazardous situation which, if not avoided, **COULD** result in **DEATH** or **SERIOUS INJURY**.



 **CAUTION**

Indicates a hazardous situation which, if not avoided, **COULD** result in **MINOR** or **MODERATE INJURY**.

**NOTICE**

Addresses practices not related to personal injury.

Potential hazards associated with the operation of this equipment will be referenced with hazard symbols which may appear throughout this manual in conjunction with safety messages.

Symbol	Safety Hazard
	Burn hazards
	Electric shock hazards

# SAFETY INFORMATION

## GENERAL SAFETY

### CAUTION

- **NEVER** operate this equipment without proper protective clothing, shatterproof glasses, respiratory protection, hearing protection, steel-toed boots and other protective devices required by the job or city and state regulations.



- **NEVER** operate this equipment when not feeling well due to fatigue, illness or when under medication.



- **NEVER** operate this equipment under the influence of drugs or alcohol.



- **ALWAYS** check the equipment for loosened threads or bolts before starting.

- **DO NOT** use the equipment for any purpose other than its intended purposes or applications.

### NOTICE

- This equipment should only be operated by trained and qualified personnel 18 years of age and older.
- Whenever necessary, replace nameplate, operation and safety decals when they become difficult read.
- Manufacturer does not assume responsibility for any accident due to equipment modifications. Unauthorized equipment modification will void all warranties.
- **NEVER** use accessories or attachments that are not recommended by Multiquip for this equipment. Damage to the equipment and/or injury to user may result.
- **ALWAYS** know the location of the nearest **fire extinguisher**.
- **ALWAYS** know the location of the nearest **first aid kit**.
- **ALWAYS** know the location of the nearest phone or **keep a phone on the job site**. Also, know the phone numbers of the nearest **ambulance, doctor and fire department**. This information will be invaluable in the case of an emergency.



# SAFETY INFORMATION

## LIGHTING SYSTEM SAFETY

### WARNING

- **NEVER** disconnect any **emergency or safety devices**. These devices are intended for operator safety. Disconnection of these devices can cause **severe injury, bodily harm or even death**. Disconnection of any of these devices will void all warranties.

### CAUTION

- **NEVER** attempt service on a running machine.

### NOTICE

- To prevent the lighting system from overturning, **NEVER** use in winds that exceed 22 mph (10 m/s).
- The lighting system should only be used in temperatures between 23° to 104°F (-5° to 40° C). Failure to comply with these operating parameters could cause the lamp to malfunction and shorten the ballast life.
- **ALWAYS** keep the lighting system in proper running condition.
- Fix damage to lighting system and replace any broken parts immediately.
- **ALWAYS** store equipment properly when it is not being used. Equipment should be stored in a clean, dry location out of the reach of children and unauthorized personnel.

## LAMP SAFETY

### WARNING

- **NEVER** attempt to replace lamp with the power on. Always unplug the power cord from the generator or power source when changing the lamp.
- **ALWAYS** allow a sufficient amount of time for the lamp to **cool** before changing. The possibility exists of severe burns.

### CAUTION

- **NEVER** use force when installing the lamp. Excessive force could cause the lamp to break, causing bodily harm.

### NOTICE

- **NEVER** leave any grease or oil residue on lamp surface when replacing or removing lamp. This can create hot spots, reducing the service life of the lamp.
- **ALWAYS** make sure lamp surface is clean and dry.
- **ALWAYS** replace with MQ recommended type lamp. See parts section of this manual.
- If applicable, **ALWAYS** make sure the lamp guard is installed correctly. **NEVER** deform the lamp guard.
- **NEVER** unplug the lamp's AC power cable during operation.
- **ALWAYS** have a **trained technician** to install and remove lamp or replace any damaged fixture wiring.

## TRANSPORTING SAFETY

### NOTICE

- When transporting the tripod lighting system, if applicable, always place in **stow position** and place tripod in its carrying case.
- **ALWAYS** remove balloon/lamp assembly from the mast when transporting lighting system. This will prevent damage to the bulb due to vibration.
- **NEVER** leave the balloon/lamp exposed during transport. Exposure to excess wind or rain could damage the balloon's nylon cover.
- **ALWAYS** place balloon inside its protective cover during transport. Be sure the cover is secured tightly around the balloon/lamp assembly.

# SAFETY INFORMATION

## BALLOON SAFETY

### WARNING

- To prevent serious burns, **NEVER** touch or unzip the balloon envelope when the lamp is on.



### CAUTION

- **ALWAYS** keep the balloon away from sharp objects and excessive amounts of heat.

### NOTICE

- To prevent balloon deformation, **NEVER** use lighting system in strong winds.
- **DO NOT** place the balloon inside its protective cover until the lamp has had a sufficient amount of time to cool down. This will prevent the balloon's nylon cover from being burned (touching the lamp surface).
- **ALWAYS** place the balloon inside its protective cover after each use. This will prolong the life of the balloon material, keeping it protected from harsh environmental elements.
- Replace balloon immediately if damaged. A damaged balloon will not inflate properly, and may become more damaged by touching the hot lamp surface.
- **DO NOT** use excessive force when zipping and unzipping the balloon. Be gentle with the zipper mechanism. If the zipper is broken, the balloon will become unusable.

## MAST SAFETY

### CAUTION

- When raising or lowering the mast, keep hands and fingers clear of the various mast sections, this will prevent hands and fingers from getting pinched.
- **NEVER** attach anything to the mast.
- **ALWAYS** lower the mast when not in use, or if high winds or electrical storms are expected in the area.

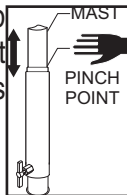

## ELECTRICAL SAFETY

### DANGER

- Lighting system is equipped with a ground pin on the power plug. For your protection, **ALWAYS** complete the grounding path. **NEVER** insert the AC power plug into a 2-prong receptacle to operate lighting system.

When applying power to the lighting system, **ALWAYS** connect the AC power plug to a 3-prong receptacle that is grounded. The possibility exists of **electrical shock, electrocution and even death** if the lighting system is not grounded.

- **NEVER** operate lighting system or handle any electrical equipment while standing in water, while barefoot, while hands are wet or in the rain. A dangerous **electrical shock** could occur, causing **severe bodily harm or even death**.
- **ALWAYS** make sure the area above the lighting system is open and clear of overhead power lines and other obstructions. Contact with overhead power lines or other obstructions could result in equipment damage, **electrical shock, electrocution and even death**.

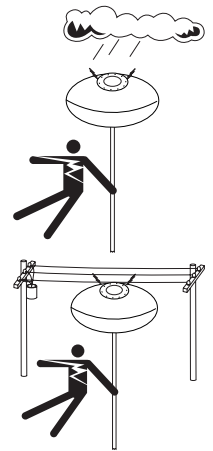

## Power Cord/Cable Safety

### DANGER

- **NEVER** let power cords or cables **lay in water**.
- **NEVER** use **damaged** or **worn** cables or cords. Inspect for cuts in the insulation
- **NEVER** grab or touch a live power cord or cable with wet hands. The possibility exists of **electrical shock, electrocution or death**.
- Make sure power cables are securely connected. Incorrect connections may cause **electrical shock** and damage to the lighting system.

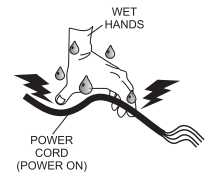

### NOTICE

- **ALWAYS** make certain that proper power or extension cord has been selected for the job. See Cable Selection Chart in this manual.

# SPECIFICATIONS

Table 1. Specifications	
<b>Globug Lighting System</b>	
Model	GB12BW/BS/BP
Input Voltage	90-130,170-240 VAC
Ballast	Electronic Ballast (50Hz/60Hz)
Frequency	50 Hz/ 60 Hz Single-Phase
Max. Current	3.8 Amps
<b>Lamp</b>	
Lamp Type	400 Watt Metal Halide
Lumens	34,200
Light Coverage (360°)	90 ft. (27.4 meters)
Surface Temperature (Longitudinal)	476.6°F (247°C) Max.
Surface Temperature (Transversal)	417.2°F (214°C) Max.
<b>Fan Motor</b>	
Balloon Fan Motor	24 VDC
Max. Current	1.2 A
Pressure	0.324 kPA (0.047 psi)
<b>Balloon</b>	
Diameter	33 in. (850 mm)
Material	Polyester
Heat Resisting Temperature	320 ~ 356°F (160 ~ 180°C)
Melting Temperature	500°F (260°C)
Internal Temperature of Balloon	126°F (52°C) Average
Water Resistance	1,500 mm H <sub>2</sub> O
<b>Mast (GB12BW)</b>	
Number of Stages	2
Maximum Height (Standard)	10 feet (3 meters)
Extension Pole	13 feet (4 meters)



# DIMENSIONS (GB12BW)

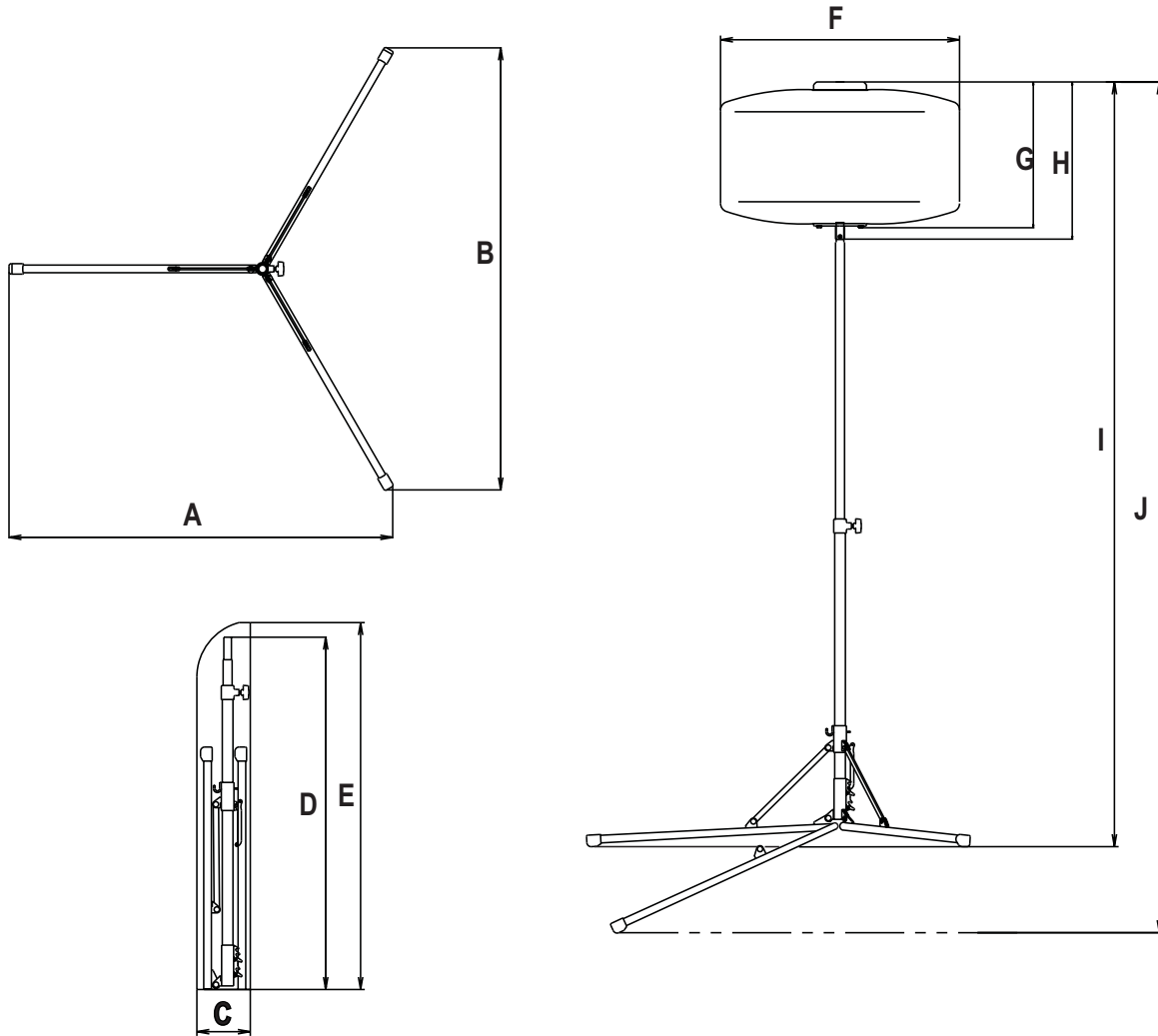
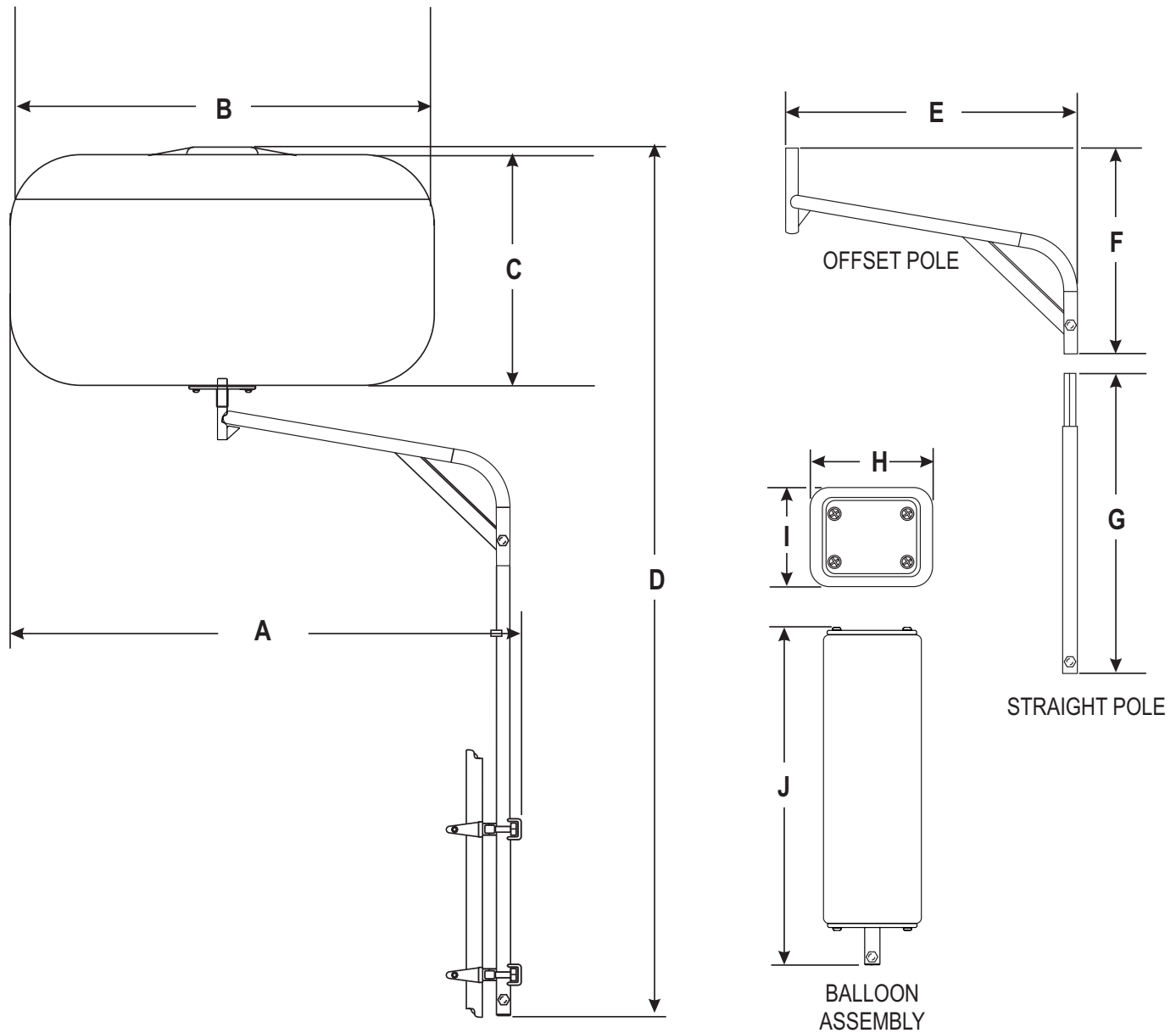

Figure 1. Dimensions (GB12BW)

Table 2. Dimensions			
Reference Letter	Dimension in. (mm.)	Reference Letter	Dimension in. (mm.)
A	Upper Position - 44.7 in. (1,135 mm.) Lower Position - 52.4 in. (1,330 mm.)	F	33.5 in. (850 mm.)
B	Upper Position - 52.2 in. (1,325 mm.) Lower Position - 62.0 in. (1,575 mm)	G	22 in. (560 mm.)
C	7.5 in. (190 mm.)	H	23.6 in. (600 mm.)
D	49.5 in. (1,258 mm.)	I	79.2 - 111 in. (1910 - 2820 mm.)
E	51.2 in. (1,300 mm.)	J	90.4 - 126.2 in. (2295 - 3205 mm.)

## DIMENSIONS (GB12BS)



**Figure 2. Dimensions (GB12BS)**

Table 3. Dimensions			
Reference Letter	Dimension in. (mm.)	Reference Letter	Dimension in. (mm.)
A	43.7 (1110)	F	16.7 (425)
B	33.4 (850)	G	39.3 (1000)
C	21 (535)	H	8.7 (220)
D	74.6 (1895)	I	7.8 (200)
E	26.8 (683)	J	23.6 (600)

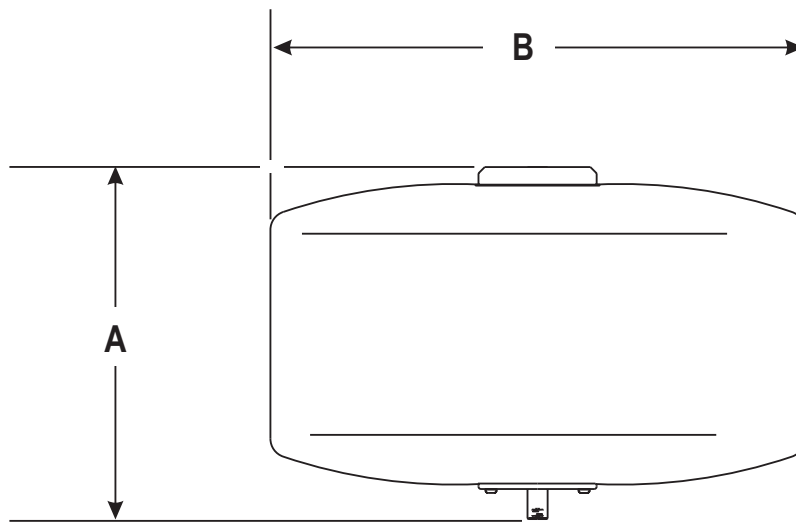
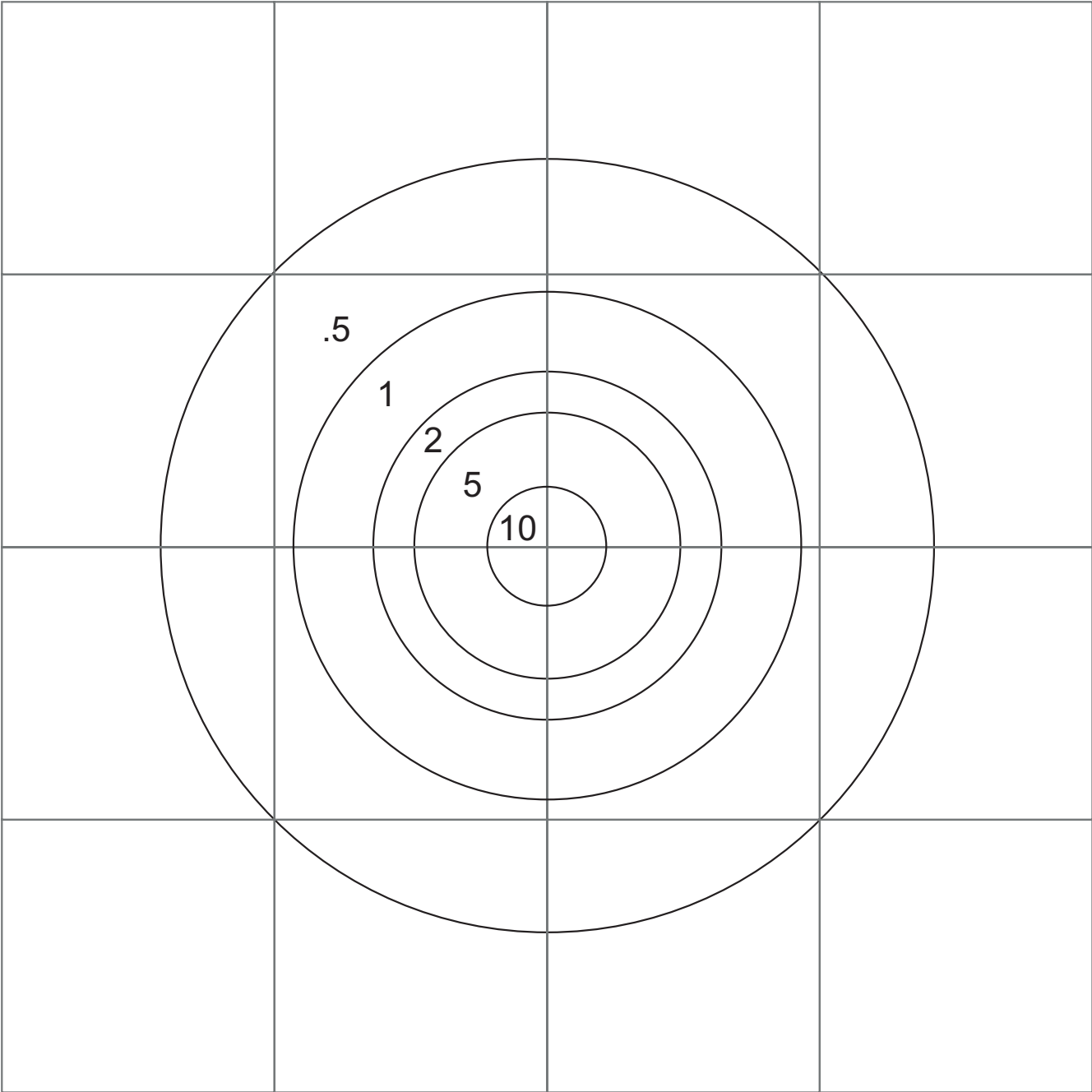

Figure 3. Dimensions (GB12BP)

Table 4. Dimensions	
Reference Letter	Dimension in. (mm.)
A	23.6 in. (600 mm.)
B	33.0 in. (850 mm.)

**FOOTCANDLE PLOT**



Values listed as footcandles

Scale: Grid = 50 ft. (15.25 meters)

**Figure 4. Floodlight Candle Plot (BAL 85-Drum Shaped)  
300-Degree Coverage**

## GENERAL INFORMATION

The Multiquip GloBug GB12W, GB12BS and GB12BP are general purpose, portable, glare-free lighting systems. Typical applications for these types of lighting systems include construction sites, emergency road crews and backyard parties.

### BALLOON ENVELOPES

The GloBug lighting system can be configured with a variety of balloon envelopes (canopy). Please contact the MQ sales department for the balloon of your choice. The GloBug GB12BW, GB12BS and GB12BP are shipped from the factory with the drum type balloon.

### LIGHTING

Multiquip's GloBug lighting system is comprised of one "Metal Halide" 400-watt lamp. This lamp has an output of 34,200 lumens. Typical lighting coverage is in excess of 90 feet (27 meters) in a 360 degree pattern.

### POWER

These GloBug lighting systems are powered by a light weight electronic ballast that is built inside the lamp housing. The input power requirements for operating the lighting system is 120 VAC, 60 Hz @ 4.5 amps.

### SETUP (GB12BW)

The GB12BW lighting system can be setup quickly and easily. Tripod legs can be deployed in one quick easy step and can be adjusted to two different heights. The upper position will add an additional foot to the mast height. If desired, an optional 35-inch (900 mm) extension pole can be added to the mast height. Please contact the MQ sales department if you wish to add this feature to your system.

In addition the unit is equipped with an air-assist mast lowering system. This system allows the mast to be retracted slowly so that the mast will not fall rapidly when released. This feature reduces the amount of vibration or shock to the lamp.

### SETUP (GB12BS)

The GB12BS lighting system (offset pole) is designed to be attached to an external piece of equipment such as a paver (Figure 5). This system is equally easy to assemble. Simply attach the supplied support clamps to an external pole or support and you are ready.

### GB12BP

When only a complete lamp assembly is required, please order Model GB12BP. This model number includes the

lamp, protective guard, balloon protective covering and all other components that make up the lamp assembly.

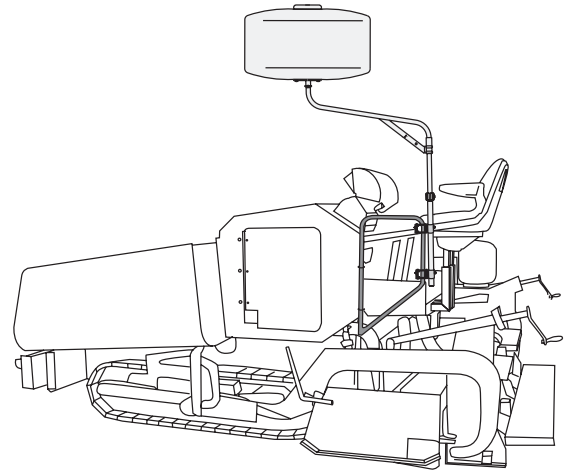

Figure 5. GB12BS Attachment (Paver)

### TRANSPORT

The GB12BW lighting system can be transported (Figure 6) quite easily in two carrying cases. The first case (tripod) weighs 16 lbs. (7.25 kg) and the second case (lamp assembly) weighs 15 lbs. (6.8 kg) for a combined weight of about 31 lbs. (14 kg).

For ease of service or transport, the lamp assembly is equipped with a quick-disconnect connector that allows the lamp fixture to be removed quickly. This feature is extremely useful during transport of the lighting system. It is always best to remove the lamp and pack it safely so it will not be damaged.

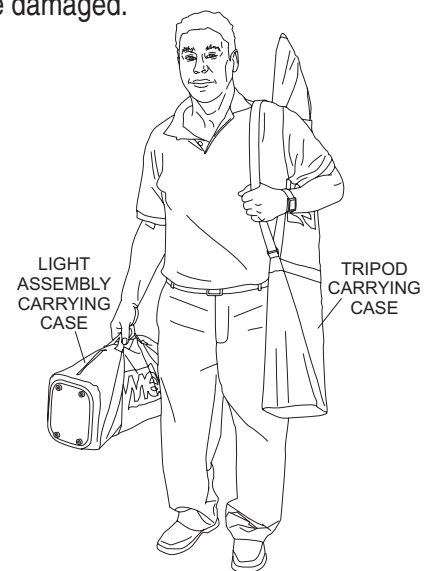

Figure 6. GB12BW Transporting

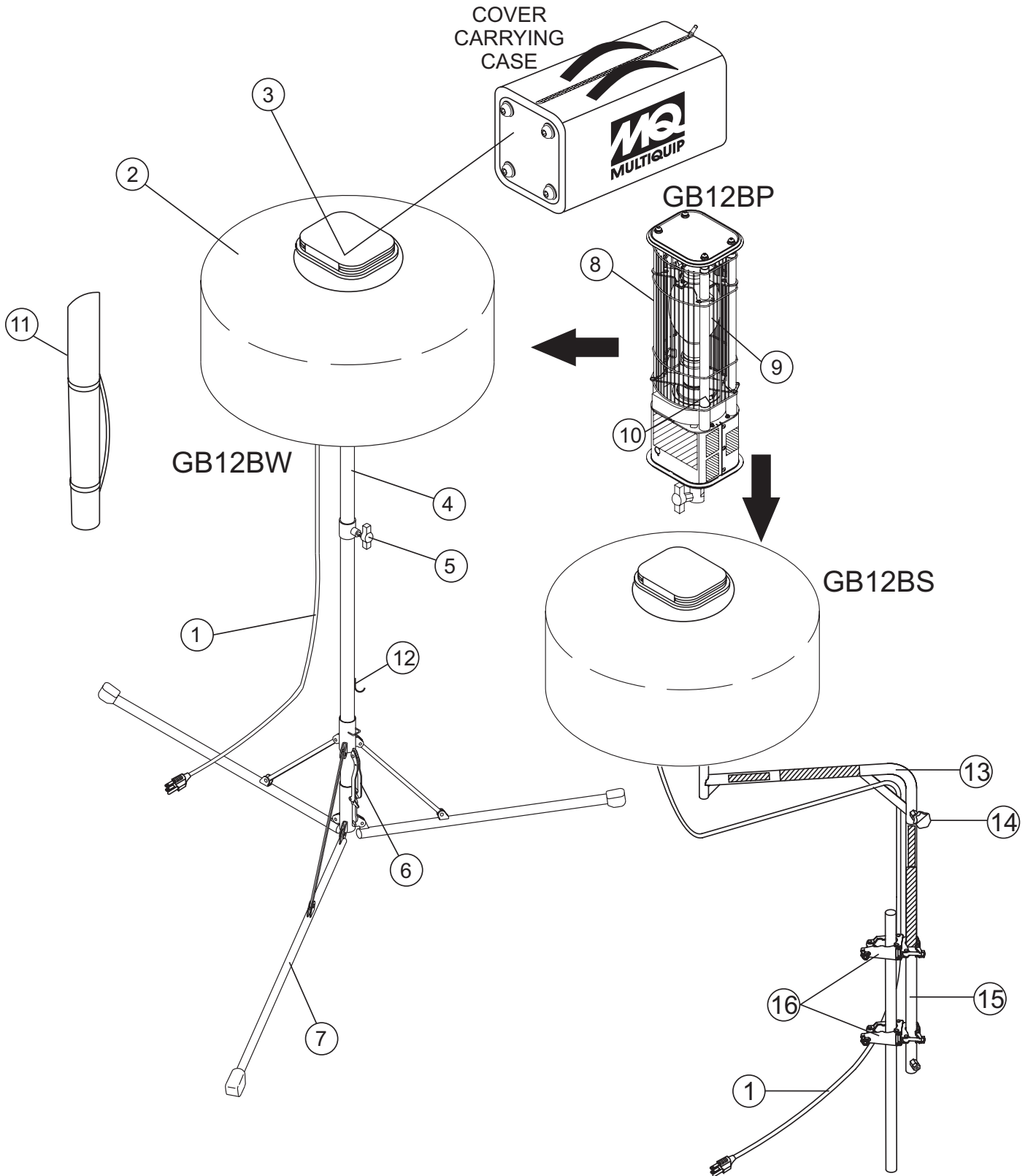

Figure 7. Major Components

## COMPONENTS

Figure 7 shows the location of the components for the GloBug lighting system. The function of each component is described below:

1. **AC Power Cable** — Connect this cable to a 120 VAC, 60 Hz power source.
2. **Balloon** — This balloon is made of heat-resistant polyester, with a diameter of 33 inches (850 mm).
3. **Balloon Cover/Carrying Case** — When zipped, this protective cover acts like a carrying case. The complete lamp assembly is enclosed within the cover-carrying case. Allow a sufficient amount of time for the lamp to cool down before covering balloon. The possibility exists of the balloon getting burned.
4. **Mast** — Two stage air-assist mast. Maximum mast height is 10 ft. (3 meters) without optional extension pole. With optional extension pole, height increases to 13 ft. (4 meters). When raising the mast, always be on the lookout for overhead obstructions.
5. **T-Handle Bolt Lock** — Always tighten this lock to hold the lamp/balloon securely in place before raising mast.
6. **Tripod Release Latch** — Use this latch to deploy and lock tripod legs. For ease of use, the latch mechanism is attached to a velcro strap.
7. **Tripod** — Unbuckle velcro strap securing tripod legs (3), push down on any tripod leg until all tripod legs are fully deployed. To place tripod legs in the stow position, pull upward on velcro strap while pushing down on tripod pole. Pull all legs upward and secure with velcro strap.
8. **Lamp Guard** — This guard (cage) protects the lamp from being hit by objects.
9. **Lamp** — 400 watt metal-halide type lamp. Replace only with MQ recommended type lamp. Always allow a sufficient amount of time for the lamp to cool down before changing.
10. **Fan Motor (Blower)** — This electric motor is responsible for inflating the balloon. It will supply a pressure of 0.6-inch H<sub>2</sub>O (.0217 psi /0.149 kPA). Please note that the balloon will begin to inflate as soon as power is applied to the lighting system.
11. **Tripod Carrying Case** — Use this case when transporting of the tripod is required. **ALWAYS** store tripod in this carrying case when not in use.
12. **Weight Support Hook** — To add additional weight to the tripod and make the tripod more stable in windy conditions. Place a sandbag or similar weight onto this hook.
13. **Offset Pole** — Supports lamp assembly when attached to the straight pole.
14. **Knob** — Secures the offset pole to the straight pole when tightened.
15. **Straight Pole** — Used in conjunction with the offset pole to support the lamp assembly.
16. **Clamps** — Used to attach the straight pole to an external support. These clamps must be tightened securely to prevent the light assembly from falling off.

## TRIPOD DEPLOYMENT (GB12BW)

1. Place the tripod on a firm level surface so that it will not slide or turn over. Make sure there is enough space around the unit for the tripod legs to be deployed.
2. Remove tripod from its carrying case. The tripod legs are secured by a black velcro strap (Figure 8). Squeeze both tabs on each side of buckle to unlock strap and allow tripod legs (Figure 9) to be deployed.

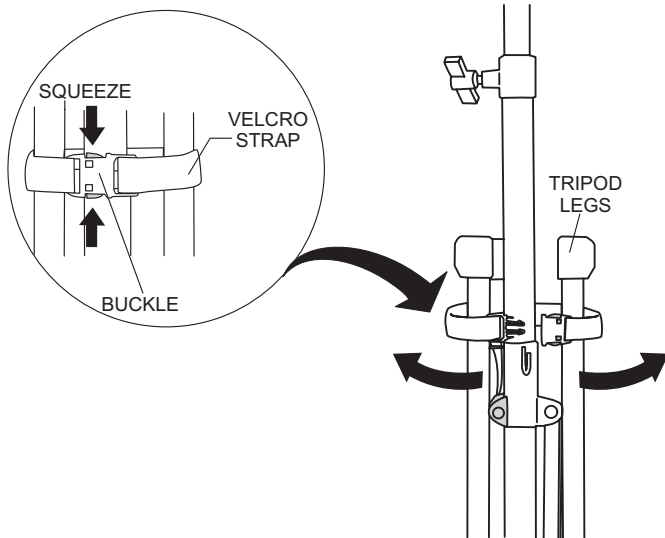

Figure 8. Velcro Strap (Open)

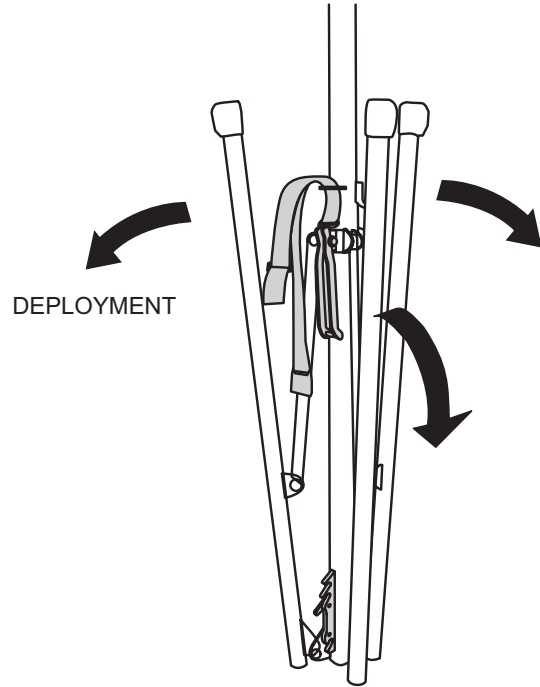

Figure 9. Tripod Deployment

3. Next, pull upward on the mast and let the tripod legs deploy. Once the tripod legs have been fully deployed make sure the legs are locked by securing the latch.

The latch (Figure 10) has two positions, upper and lower. Placing the latch in the upper position will provide 1 ft. ( 305 mm) more height.

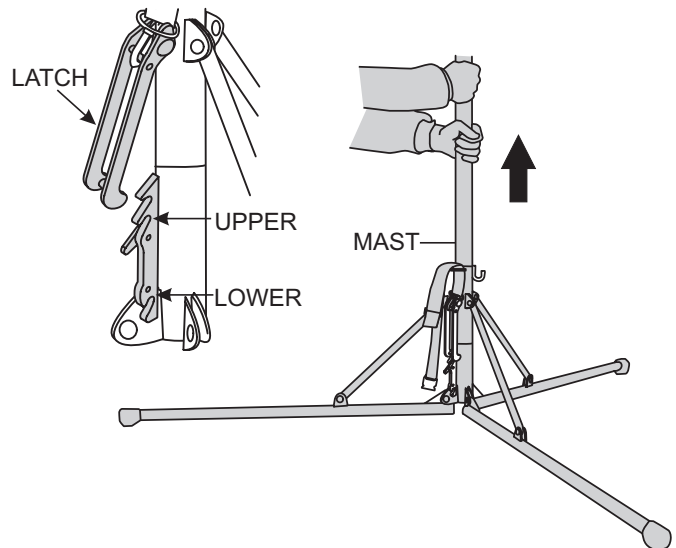
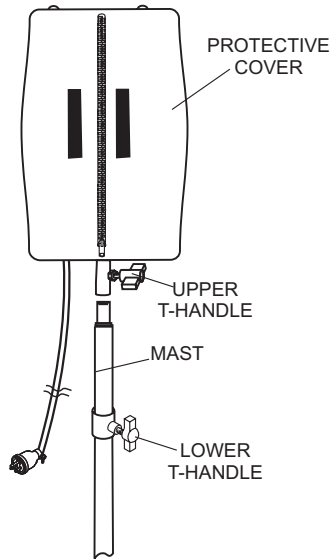

Figure 10. Securing the Tripod



## BALLOON ASSEMBLY PLACEMENT (GB12BW)

1. Place balloon assembly (Figure 11) onto mast and tighten Upper T-handle.



**Figure 11. Light Assembly Placement**

2. Expose the balloon by pulling down on the velcro tab and unzip the protective cover as shown in Figure 12. Also remove the AC power cord at this time.

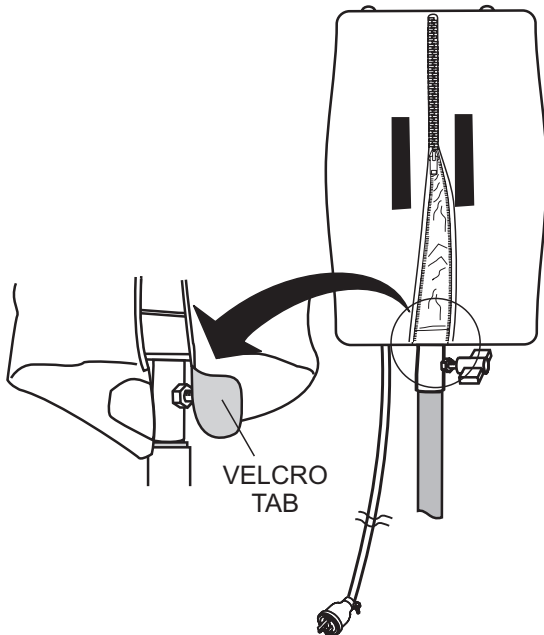

**Figure 12. Removing Balloon/AC Power Cord**

3. Next, fold the protective cover (Figure 13) into itself and zip.

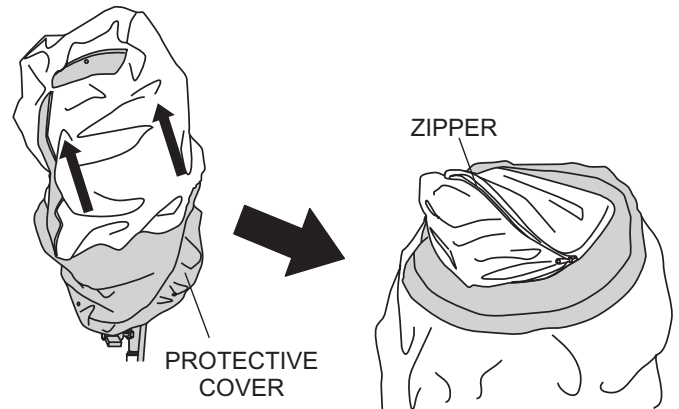

**Figure 13. Folding Protective Cover**

4. Attach the S-type hook (Figure 14) on the AC power cable onto the washer-eylet located on the bottom plate of the light assembly.

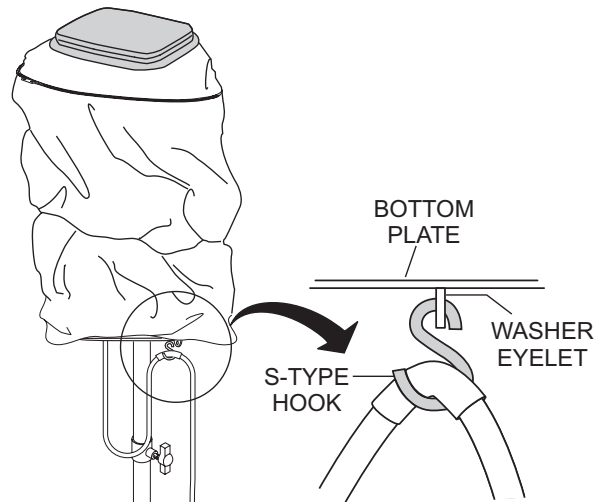

**Figure 14. Securing Power Cord**

# SETUP (GB12BW)

## RAISING THE MAST (GB12BW)

1. Before raising the mast, make sure the upper T-handle bolt lock (Figure 15) is securely tightened. This will prevent the balloon/lamp assembly from falling off. In addition make sure that the lamp power cable is connected to the mating end of the 15 ft (4.5 meters) power source cable.

**! DANGER**

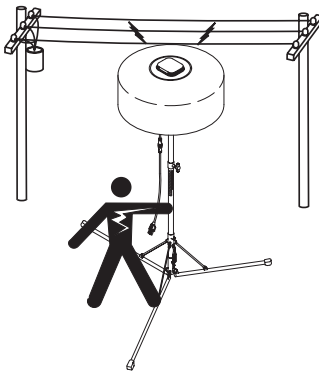

**ALWAYS** make sure the area above the lighting system is open and clear of overhead power lines and other obstructions. The mast extends in excess of 13 ft. (4 meters) when an optional extension is used. Contact with overhead power lines or other obstructions could result in equipment damage, serious injury or death!

**! CAUTION**

When raising mast, **ALWAYS** be on the lookout for overhead obstructions such as high voltage power lines. The possibility exists of electrocution, even death! if the lighting system comes in contact with high voltage power lines.

**! DANGER**



When raising mast, **ALWAYS** be on the lookout for overhead obstructions such as high voltage power lines. The possibility exists of electrocution, even death! if the lighting system comes in contact with high voltage power lines.

2. To improve stability and to prevent tipping of the light unit, place sand bags or similar type weight over the tripod legs or weight hook as shown in Figure 15.

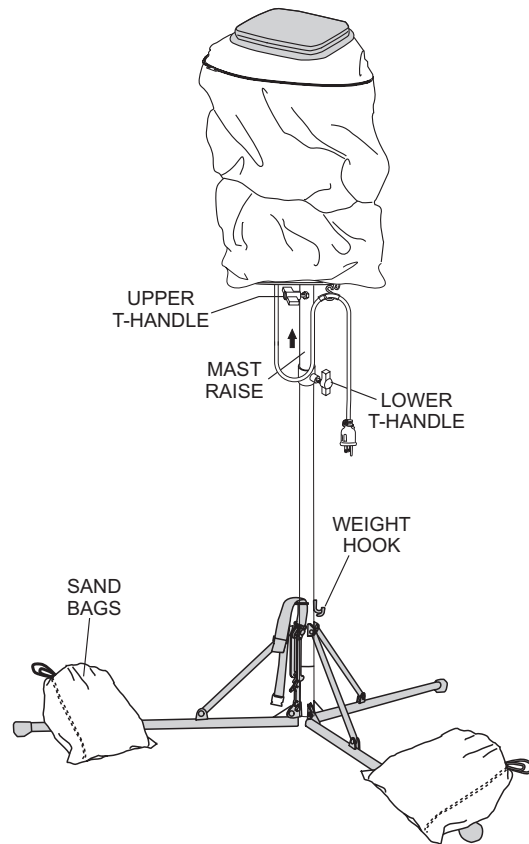

**Figure 15. Sand Bags**

3. Raise mast to desired height and tighten lower T-handle (Figure 15) securely.

# OPERATION (GB12BW)

## APPLYING POWER (GB12BW)

1. Before applying power, make sure that the Power **ON/OFF** switch (Figure 16) is in the OFF position.

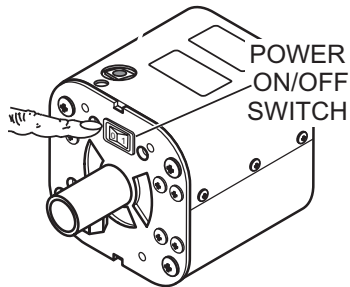

Figure 16. ON/OFF Switch

2. Connect the AC power cable to the 120 VAC receptacle on the generator used. See Figure 17.

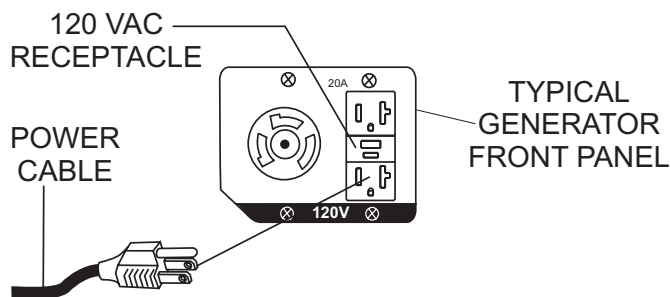

Figure 17. Connecting to Power Source

3. Start the generator as indicated in the generator manual.
4. Turn on the Power **ON/OFF** switch (Figure 16). The balloon will start to inflate and the lamp will turn on.

## DIMMING THE LAMP

1. Slightly unzip the bottom of the balloon to gain access to the dimmer switch (Figure 18).

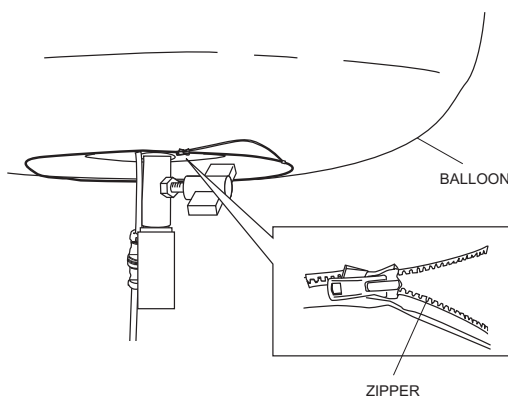

Figure 18. Unzipping Balloon

2. Press the dimmer switch lightly (Figure 19). The LED will blink. The lamp should dim to about 75% brightness.

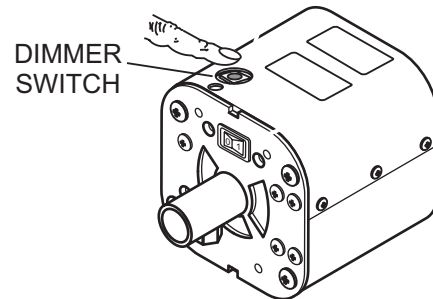

Figure 19. Dimmer Switch

3. To turn back the lamp to its original brightness, press the dimmer switch again. The LED will turn off.
4. To turn off the lamp while keeping the balloon inflated, press and hold the dimmer switch for three seconds. The LED will light red.
5. Zip up the bottom of the balloon completely after use of the dimmer switch.

### NOTICE

To turn on lamp again, after it was turned off with the dimmer switch, turn off the Power **ON/OFF** switch. Wait three to five minutes then turn the **ON/OFF** switch back on. The lamp will now light back to 100% brightness.

### NOTICE

If the power cable is accidentally unplugged from the power source, wait three to five minutes before reconnecting the power. This will allow time for the fan to reset and ensure balloon will inflate properly when power is reconnected.

## SHUTDOWN

1. Turn off the power switch of the generator.
2. Turn off the Power **ON/OFF** switch. The balloon should start to deflate and the lamp will turn off.
3. Disconnect the AC power cable from the generator.

### CAUTION

Allow a sufficient amount of time (15-20 minutes) for the lamp to cool down. The possibility exists of the balloon getting burned (touching the lamp).

## STORAGE

1. Loosen the lower T-handle by turning handle counterclockwise (Figure 20). Push down on mast until mast is fully inserted into mast housing. Tighten T-handle fully.

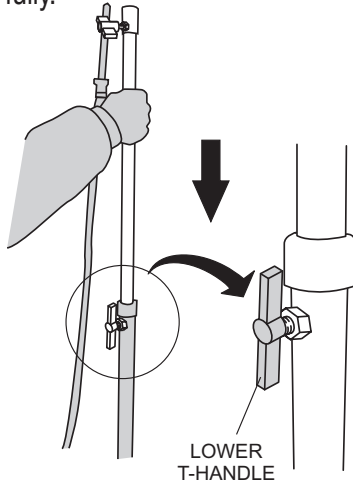

**Figure 20. Lowering the Mast**

2. Unzip the zipper on the protective cover (Figure 20), and pull down cover over balloon/lamp assembly.

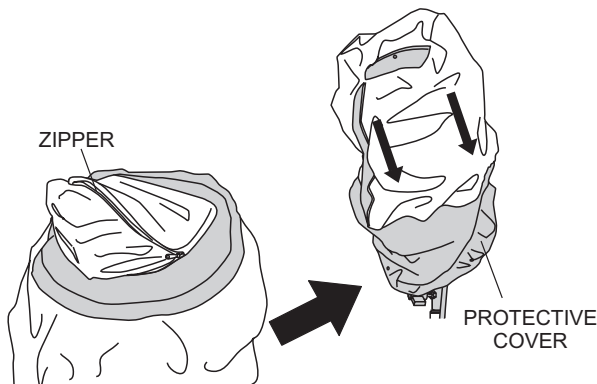

**Figure 21. Unzipping the Protective Cover**

3. Unhook lamp AC power cable from washer eyelet (Figure 14). Fully zip protective cover and fold velcro tab in place (Figure 22).

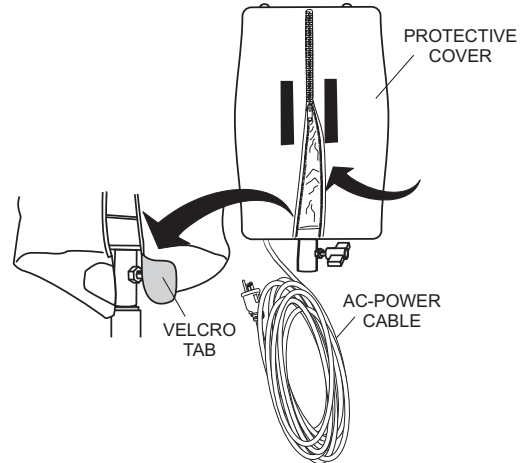

**Figure 22. Zipping the Protective Cover**

4. Loosen upper T-handle by turning counterclockwise and lift lamp assembly from mast.
5. Store lamp assembly enclosed with its protective cover (Figure 23) in a safe location where it will not be damaged.



**Figure 23. Storing Lamp Assembly**

6. To retract tripod legs (Figure 24) and place in the stow position, lift up on mast while pulling up on the velcro strap. Continue pulling upward on the mast until the tripod legs are fully retracted and are in the stow position.

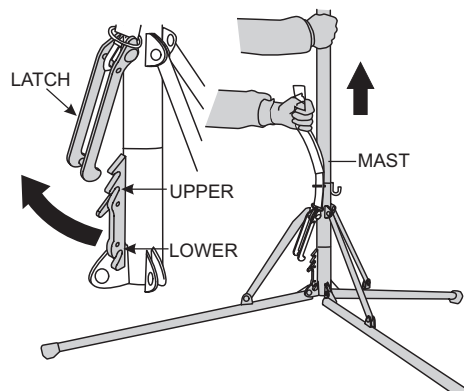

**Figure 24. Retracting Tripod Legs**

7. Once tripod legs are in the stow position, place velcro strap (Figure 25) around all three tripod legs. Secure tripod legs by inserting the male and female connector ends of the strap into each other.

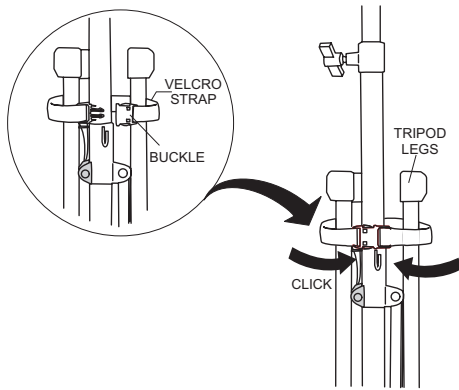

**Figure 25. Velcro Strap (Closed)**

8. Place tripod (Figure 26) inside protective carrying case.

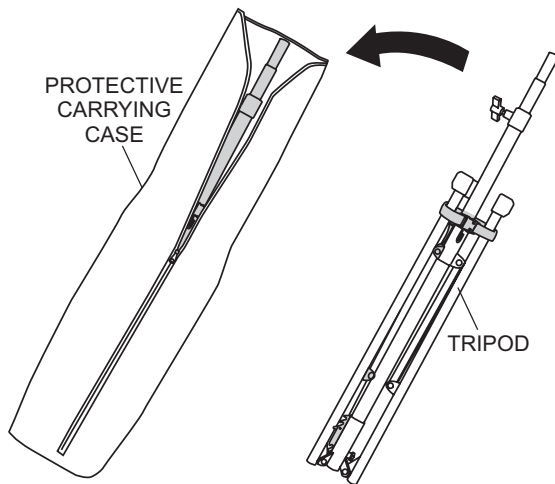

**Figure 26. Carrying Case**

## POLE SETUP (GB12BS)

1. Attach one of the clamps that come with the GBS to the external support pole. The clamps may be attached to vertical, horizontal, or angled pole. See Figure 27.

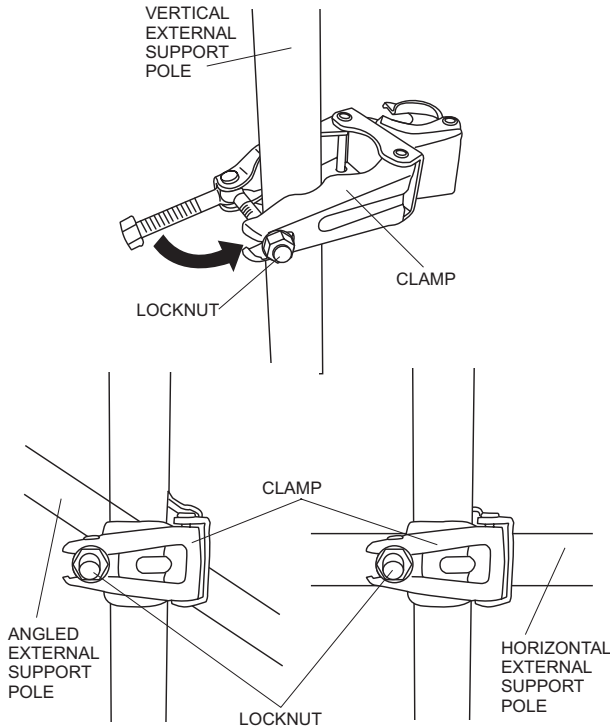

**Figure 27. Clamp Attachment**

2. Using a 19 mm wrench, tighten the locknut securely. See Figure 11.
3. Attach the other clamp to the external support pole about 7 inches (140 mm) lower than the previously installed clamp. See Figure 28. If using horizontal external support poles, a second pole is needed.

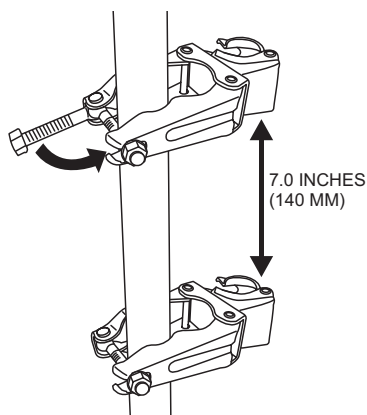

**Figure 28. Distance Between Clamps**

4. Attach the straight pole to the clamps. Tighten locknuts on both clamps. See Figure 29.

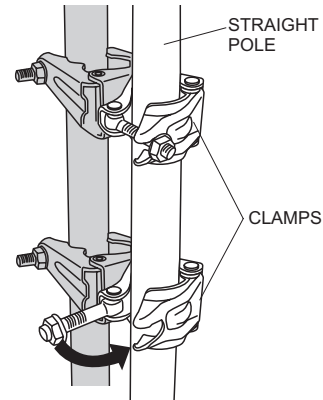
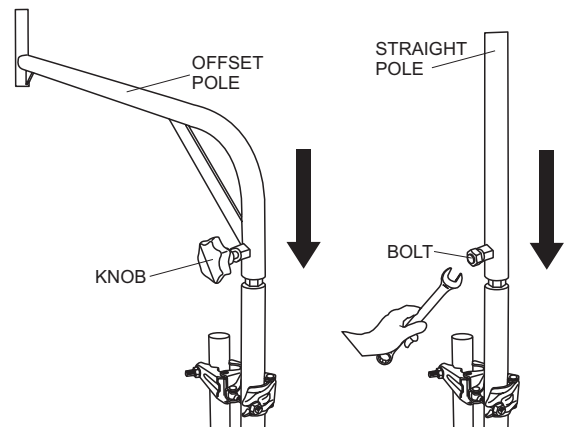

**Figure 29. Straight Pole Attachment**

### **WARNING**

Always securely tighten the locknuts when assembly is used to prevent the lighting system from falling off which can cause injury or equipment damage.

5. Place the offset pole (or an optional straight pole, if desired) on top of the straight pole. Tighten knob or bolt securely. See Figure 30.



**Figure 30. Offset Pole Attachment**

### **WARNING**

Always securely tighten the knob on the offset or the bolt on the straight pole when assembly is used to prevent the lighting system from falling off which can cause injury or equipment damage.

## SETUP (GB12BS)

### REMOVING THE PROTECTIVE COVERING (GB12BS)

1. Expose the balloon by pulling down on the velcro tab and unzipping the protective cover as shown in Figure 31.

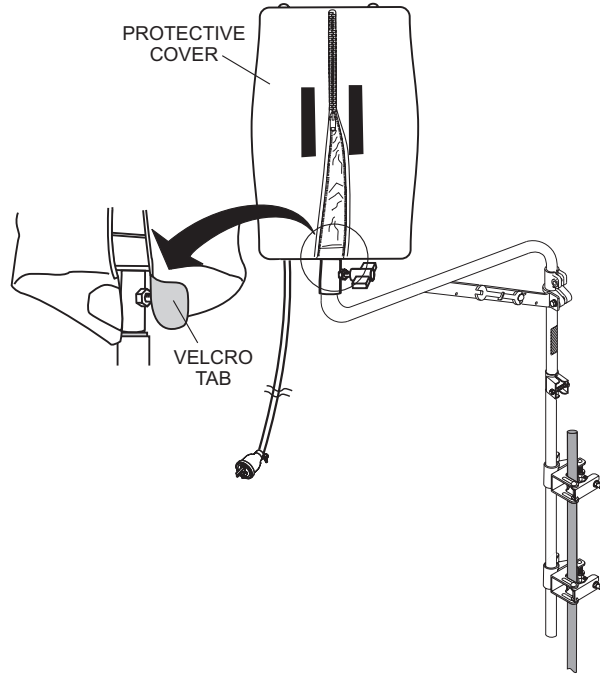

**Figure 31. Removing Balloon/AC Power Cord**

2. Next, fold the protective cover (Figure 32) into itself and zip.

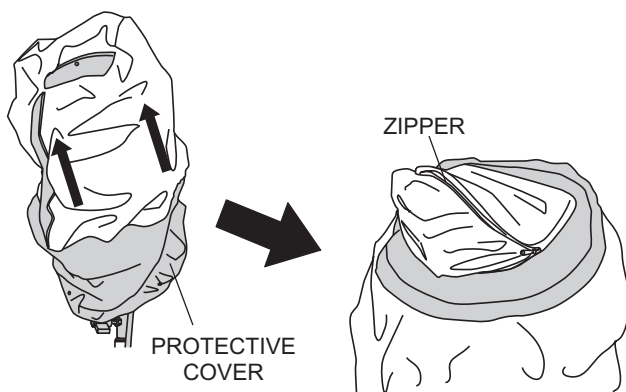

**Figure 32. Folding Protective Cover**

3. Attach both S-type hooks (Figure 33) on the AC power cable into the cable support holes on the offset pole.

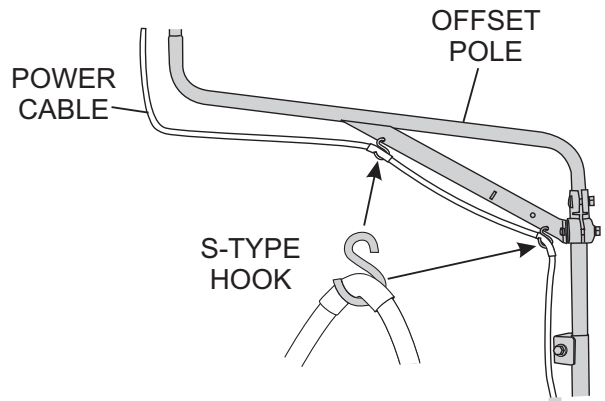

**Figure 33. Attachment of S-Hooks**

# OPERATION (GB12BS)

## RAISING THE MAST (GB12BS)

1. Before raising the mast, make sure the T-handle bolt lock is securely tightened. This will prevent the balloon/lamp assembly from falling off.
2. Raise extension pole to desired height. Watch out for any overhead obstructions.
3. Tighten extension clamp bolt securely.

**! DANGER**

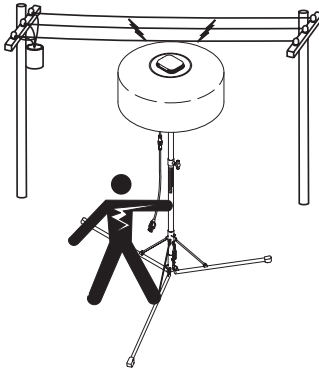

**ALWAYS** make sure the area above the lighting system is open and clear of overhead power lines and other obstructions. The mast extends in excess of 13 ft. (4 meters) when an optional extension is used. Contact with overhead power lines or other obstructions could result in equipment damage, serious injury or death!

**! DANGER**



When raising mast, **ALWAYS** be on the lookout for overhead obstructions such as high voltage power lines. The possibility exists of electrocution, even death if the lighting system comes in contact with high voltage power lines.

## APPLYING POWER (GB12BS)

1. If using a portable generator, start the generator as referenced in the "Start-up Section" of the supplied generator manual.
2. Once the generator has started, plug the AC power cord from the lamp into a GFCI receptacle on the generator.
3. If using a power source (Figure 34) other than a portable generator, plug the AC power cord from the lamp into a 120 VAC, 60 Hz receptacle that is protected by a at least a 15 amp circuit breaker.

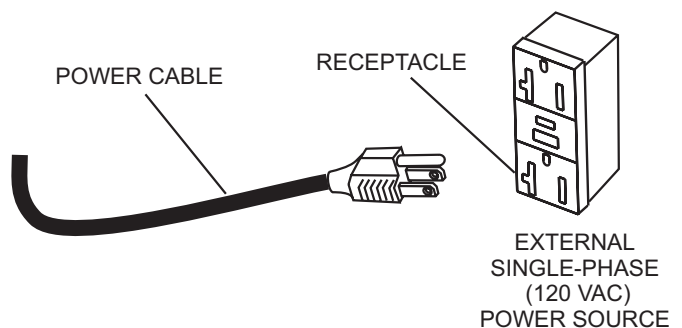

Figure 34. 120 VAC Receptacle

### NOTICE

Refer to previous sections on Applying Power (GB12BW), Dimming the Lamp, and Shutdown for procedures in operating the lamp.



## REPLACING THE LAMP

1. Allow lamp (Figure 35) 15-20 minutes to cool before changing.

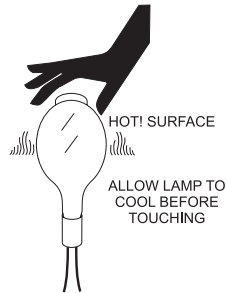

**Figure 35. Hot Lamp Surface**

2. If lamp assembly is attached to mast, loosen upper T-handle bolt lock that secures the lamp to the mast and remove.
3. Unzip the zipper at the bottom of the balloon. **DO NOT** use excessive force when unzipping the balloon.
4. Place lamp/balloon assembly on a suitable work bench that is free of dirt, and sharp objects that could damage the balloon.

### NOTICE



**DO NOT** use excessive force when zipping or unzipping the balloon. The possibility exists of the zipper tearing, which would make the balloon unusable.

5. Roll the balloon envelope (Figure 36) upwards to expose the lamp.

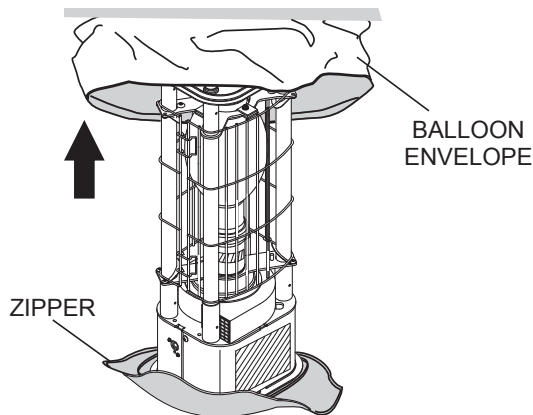

**Figure 36. Rolling up Balloon Envelope**

6. Release the lamp guard locking tabs (Figure 37).

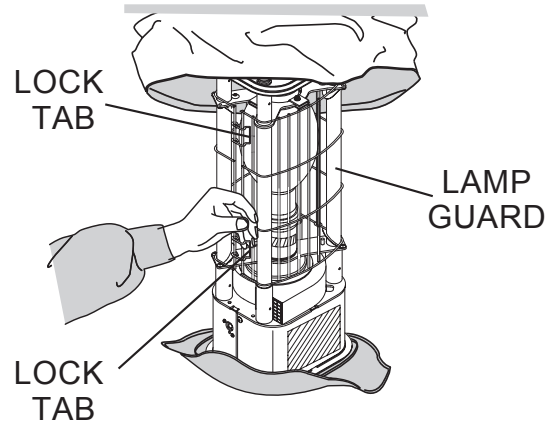

**Figure 37. Releasing Lamp Guard Locking Tabs**

7. Remove lamp guard (Figure 38).

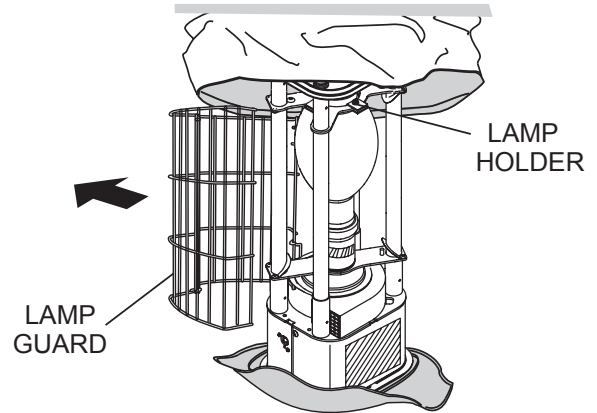

**Figure 38. Lamp Guard Removal**

8. Press tabs on the lamp holder and lift up holder to release lamp. Remove lamp (Figure 39) from lamp socket by turning lamp in a counterclockwise direction.

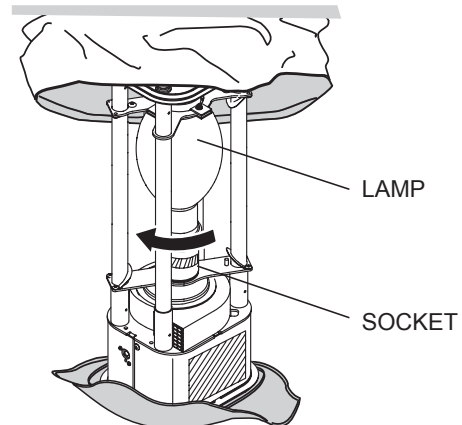

**Figure 39. Removing Lamp**

9. Install replacement lamp (Figure 40) into lamp socket and turn lamp in a clockwise direction until tight. Press tabs on the lamp holder and slowly bring down the holder to secure lamp in place.

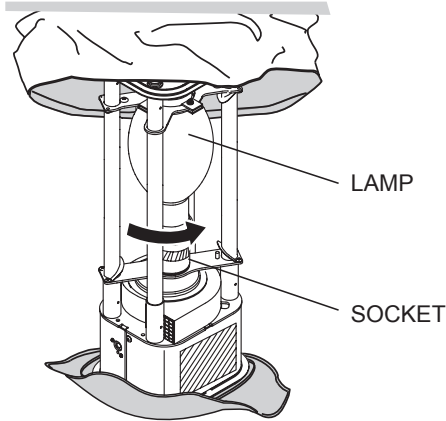

**Figure 40. Installing Lamp**

## REPLACING BALLOON ENVELOPE

1. Unzip the zipper (Figure 38) at the top and bottom of the balloon envelope (cover).

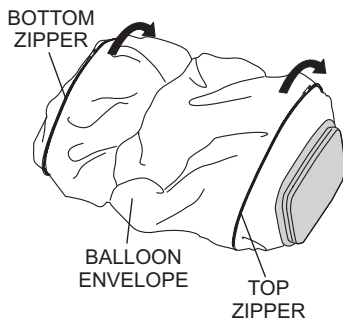

**Figure 41. Unzipping the Balloon Envelope**

2. Slide the old or worn balloon envelope (Figure 42) over the top of the lamp guard assembly.

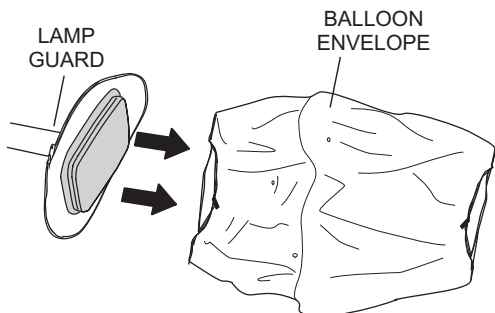

**Figure 42. Removing the Balloon Envelope**

3. Slide the new balloon (Figure 43) envelope over the top of the lamp guard assembly.

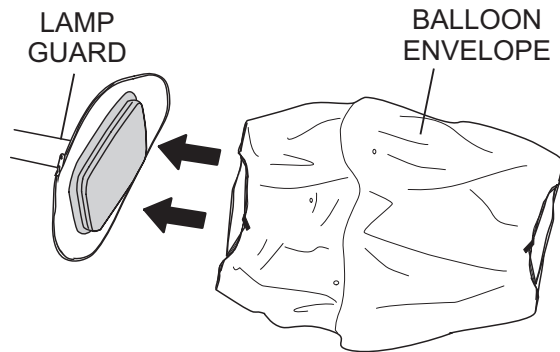

**Figure 43. Installing New Balloon Envelope**

4. Zip up the zipper (Figure 44) at the top and bottom of the balloon envelope (cover).

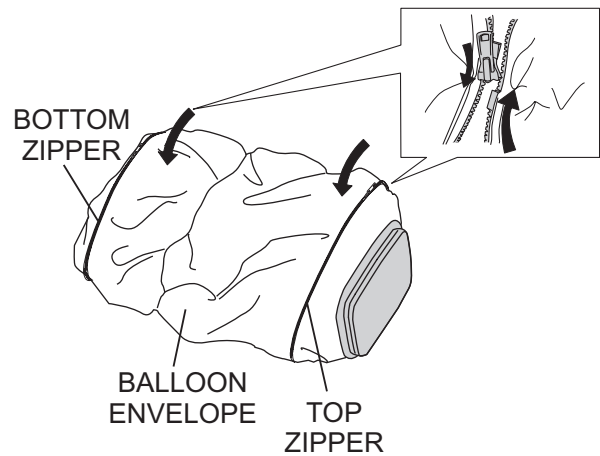

**Figure 44. Zipping the Balloon Envelope**

## FILTER REPLACEMENT

1. Remove the balloon as described in the STORAGE section.
2. Turn the balloon/lamp assembly upside down to access the filter. See Figure 45.

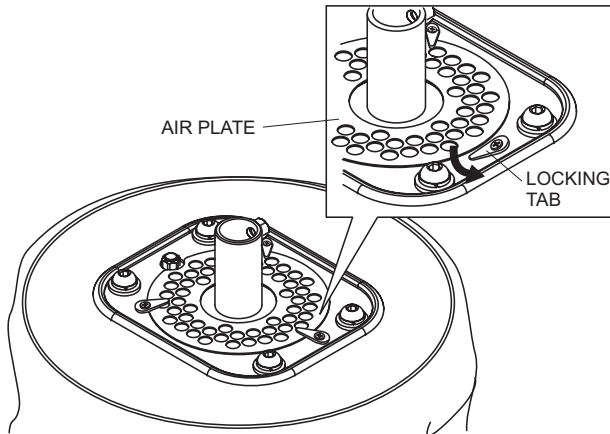

**Figure 45. Accessing Filter**

3. Turn the three locking tabs outwards to release the air plate. See Figure 45.
4. Remove the air plate and filter. See Figure 46.

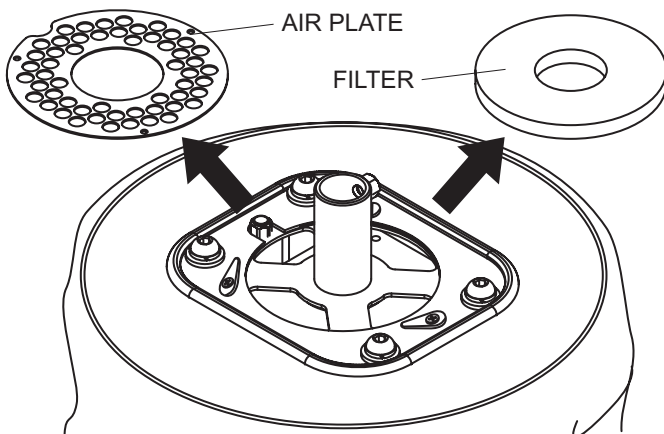

**Figure 46. Filter Removal**

5. Install a new filter and reinstall the air plate.

6. Turn the three locking tabs inwards to lock the air plate in place. See Figure 47.

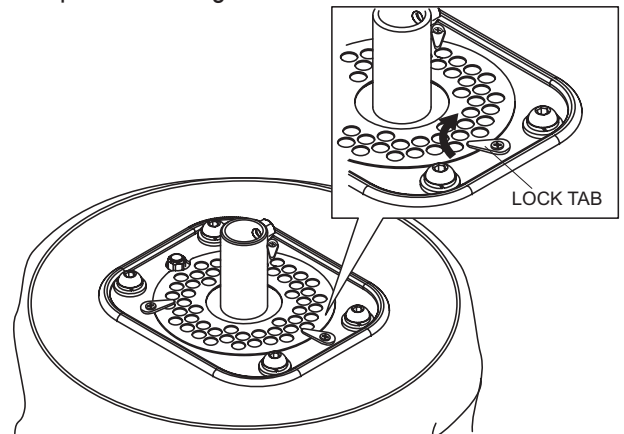

**Figure 47. Locking Air Plate**

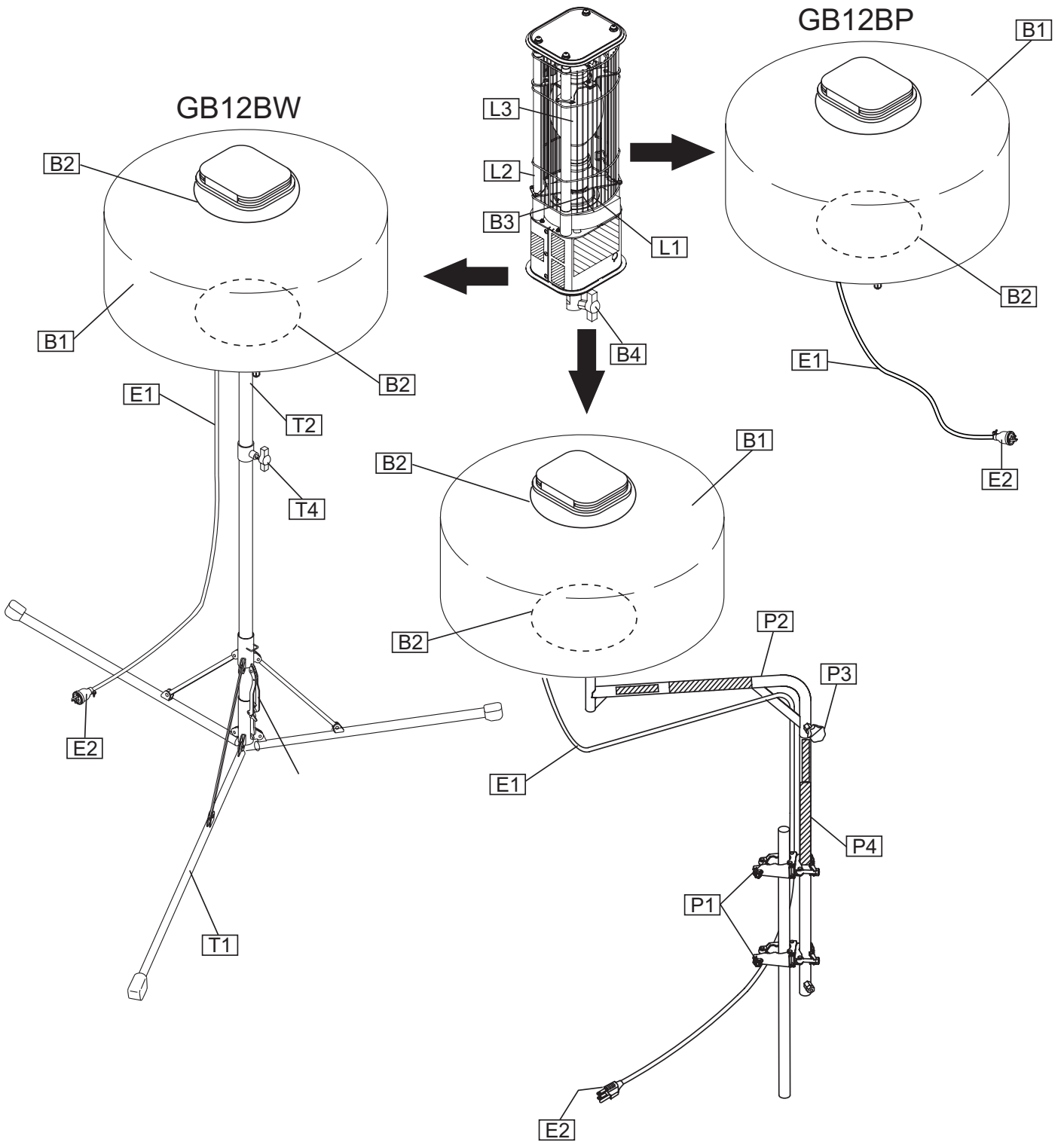

Figure 48. Maintenance Check Points

# MAINTENANCE

For a prolonged life cycle an extended quality follow the recommended GloBug lighting system service guidelines as referenced in Figure 48 and Table 6.

**Table 5. Periodic Check and Maintenance**

Figure		Part	Check Item	Solution	
Lamp	L1	Lamp (Base)	Lamp base loose?	Screw in securely	❖
	L2	Pipe Frame	Frame pipe skewed?	Replace	❖
	L3	Lamp	Defective lamp?	Replace	■
Balloon	B1	Balloon (Envelope)	Defective or dirty?	Replace	❖
	B2	Zipper	Broken?	Replace	❖
	B3	Fan Motor (Blower)	Not working properly?	Repair or replace	❖
	B4	T-Handle bolt (Balloon)	Broken?	Replace	❖
Electric	E1	Power Cable	Defective or worn cable?	Replace.	❖
	E2	Plug	Damaged?	Replace	❖
Tripod	T1	Tripod	Damaged or not working properly?	Replace	■
	T2	Mast	Damaged or not working properly?	Replace	❖
	T3	Latch	Damaged?	Replace	❖
	T4	T-Handle bolt (Mast)	Damaged?	Replace	❖
Pole	P1	Clamp	Broken?	Replace	❖
	P2	Offset pole	Offset pole bent or damaged?	Replace	❖
	P3	Knob	Loose?	Tighten securely	❖
	P4	Straight pole	Straight pole bent or damaged?	Replace	❖

❖ - Daily Check    ■ - Every 20 Hours

# WIRING DIAGRAM

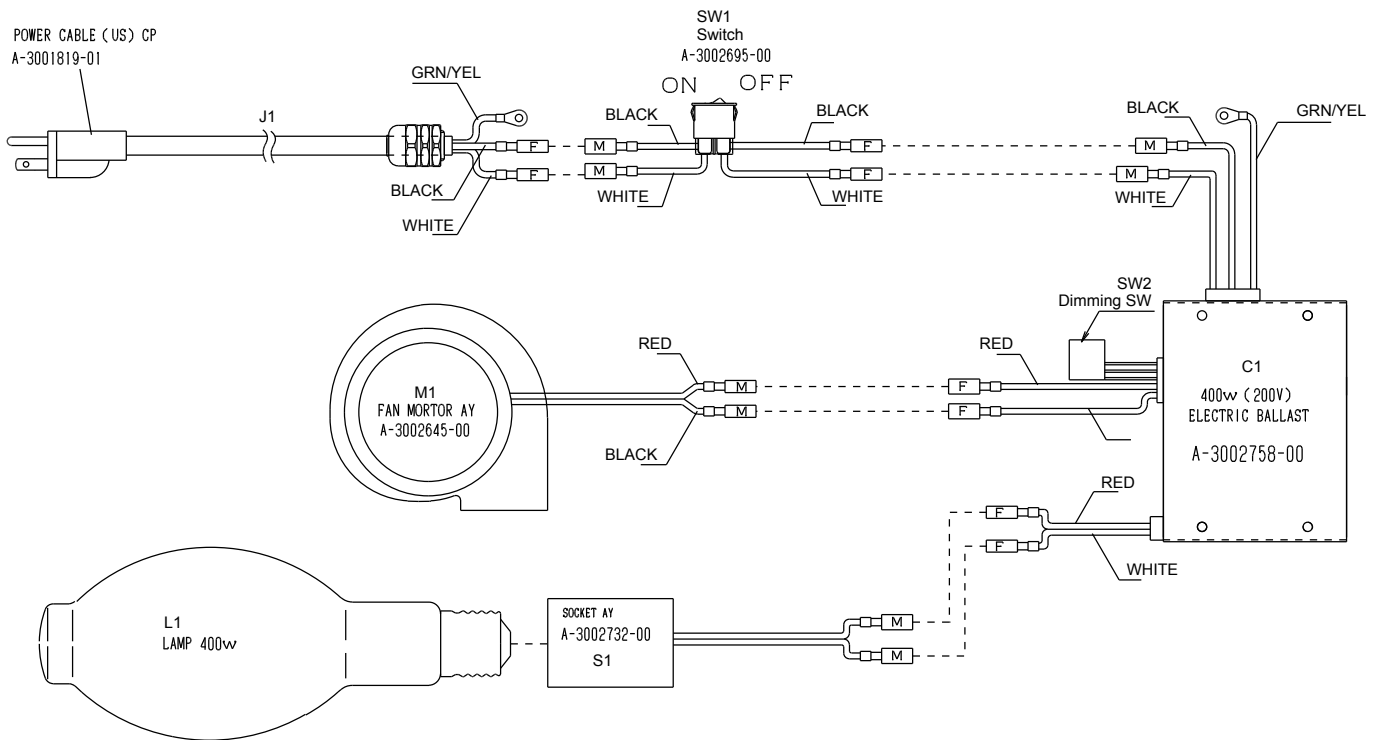

Figure 49. Electrical Wiring Diagram

Table 6. Reference Designations on Electrical Wiring Diagram

Reference Designator	Description	Part Number
J1	Cable CP	A300181901
C1	E-Ballast	A300275800
S1	Socket Assy	A300273200
L1	Lamp, 400 W	E000125500
SW1	ON/OFF Switch	A300269500
SW2	Dimming Switch	N/A (included with C1)

# TROUBLESHOOTING

Practically all breakdowns can be prevented by proper handling and maintenance inspections, but in the event of a breakdown, please take a remedial action following the diagnosis based on the Lamp Troubleshooting (Table 7) and Mast Troubleshooting (Table 8) information shown below.

If the problem cannot be remedied, please leave the unit just as it is and consult or company's service department.

<b>TABLE 7. LAMP TROUBLESHOOTING</b>		
<b>SYMPTOM</b>	<b>POSSIBLE PROBLEM</b>	<b>SOLUTION</b>
Lamp does not light.	Is plug disconnected?	Plug in correctly.
	Is lamp power switched off?	Turn on switch.
	Is lamp loose?	Screw lamp securely into socket.
	Is power connector disconnected or loose?	Connect disconnected connector.
	Are any other electric appliances (other than light tower) plugged into power source?	Unplug all other appliances.
	Is model of lamp incompatible?	Use genuine MQ lamp.
	Is lamp not cool enough to light again? (Interval of 20 to 30 minutes is required before turning on lamp again)	Wait for lamp to cool down.
Lamp only lights for a short time.	Is ambient temperature too high (more than 104 °F (40 °C))?	Move lamp where there is proper ventilation.
Balloon does not inflate.	Is fan motor (blower) not working properly?	Check or repair fan motor (blower).
	Is balloon envelope defective?	Repair or replace balloon envelope.

<b>TABLE 8. MAST TROUBLESHOOTING</b>		
<b>SYMPTOM</b>	<b>POSSIBLE PROBLEM</b>	<b>SOLUTION</b>
Mast cannot be raised.	Is Mast Lock Lever locked?	Release Mast Lock Lever.
The mast cannot be lowered.	Is Mast Lock Lever locked?	Release Mast Lock Lever.

# EXPLANATION OF CODE IN REMARKS COLUMN

The following section explains the different symbols and remarks used in the Parts section of this manual. Use the help numbers found on the back page of the manual if there are any questions.

**NOTICE**

The contents and part numbers listed in the parts section are subject to change **without notice**. Multiquip does not guarantee the availability of the parts listed.

## SAMPLE PARTS LIST

NO.	PART NO.	PART NAME	QTY.	REMARKS
1	12345	BOLT.....	1	INCLUDES ITEMS W/%
2%		WASHER, 1/4 IN.....		NOT SOLD SEPARATELY
2%	12347	WASHER, 3/8 IN....	1	MQ-45T ONLY
3	12348	HOSE .....	A/R	MAKE LOCALLY
4	12349	BEARING .....	1	S/N 2345B AND ABOVE

### NO. Column

**Unique Symbols** — All items with same unique symbol

(@, #, +, %, or >) in the number column belong to the same assembly or kit, which is indicated by a note in the “Remarks” column.

**Duplicate Item Numbers** — Duplicate numbers indicate multiple part numbers, which are in effect for the same general item, such as different size saw blade guards in use or a part that has been updated on newer versions of the same machine.

**NOTICE**

When ordering a part that has more than one item number listed, check the remarks column for help in determining the proper part to order.

### PART NO. Column

**Numbers Used** — Part numbers can be indicated by a number, a blank entry, or TBD.

TBD (To Be Determined) is generally used to show a part that has not been assigned a formal part number at the time of publication.

A blank entry generally indicates that the item is not sold separately or is not sold by Multiquip. Other entries will be clarified in the “Remarks” Column.

### QTY. Column

**Numbers Used** — Item quantity can be indicated by a number, a blank entry, or A/R.

A/R (As Required) is generally used for hoses or other parts that are sold in bulk and cut to length.

A blank entry generally indicates that the item is not sold separately. Other entries will be clarified in the “Remarks” Column.

### REMARKS Column

Some of the most common notes found in the “Remarks” Column are listed below. Other additional notes needed to describe the item can also be shown.

**Assembly/Kit** — All items on the parts list with the same unique symbol will be included when this item is purchased.

Indicated by:  
 “INCLUDES ITEMS W/(unique symbol)”

**Serial Number Break** — Used to list an effective serial number range where a particular part is used.

Indicated by:  
 “S/N XXXXX AND BELOW”  
 “S/N XXXX AND ABOVE”  
 “S/N XXXX TO S/N XXX”

**Specific Model Number Use** — Indicates that the part is used only with the specific model number or model number variant listed. It can also be used to show a part is NOT used on a specific model or model number variant.

Indicated by:  
 “XXXXX ONLY”  
 “NOT USED ON XXXX”

**“Make/Obtain Locally”** — Indicates that the part can be purchased at any hardware shop or made out of available items. Examples include battery cables, shims, and certain washers and nuts.

**“Not Sold Separately”** — Indicates that an item cannot be purchased as a separate item and is either part of an assembly/kit that can be purchased, or is not available for sale through Multiquip.



## SUGGESTED SPARE PARTS

---

### GLOBUG LIGHTING SYSTEM

#### 1 TO 3 UNITS

Qty.	P/N	Description
2.....	E000125500 .....	LAMP
2.....	A300275800 .....	ELE-BALLAST ASSY
2.....	A100015901 .....	BALLOON CLOTH

# NAMEPLATE AND DECALS (GB12BW)

**TOUJOURS fermer au loquet pour éviter le basculement.**

**⚠ DANGER**  
NEVER use without hooking the latch. The possibility exists of tipping.

**WORKSTAND DEPLOYMENT**

**SET**

1. Unfasten the band and pull legs downward at the tip end.
2. Lift up the mast to hook the latch.

**RELEASE**

1. Lift up the mast and pull the band upward to unhook the latch.
2. Pull the band upward with holding the leg until the legs place in slow position.

**BAND LATCH**

**MQ MULTICOUP** GloBug Lighting System

**HOW TO CONTROL LIGHT**

**LIGHT CONTROL:**  
Push the button. (LED is 100% / LED is dimming—75%)

**SHUTTING DOWN LAMP ONLY:**  
Push the button for three seconds. LED will turn red and lamp will turn off.

**TURNING LAMP BACK ON:**  
Turn off the lamp switch which is on the APR PLATE. LED will turn off. Turn on the lamp switch.

**← LIGHT CONTROL SWITCH**

---

**COMMENT CONTRÔLER L'ÉCLAIRAGE**

**ARRÊTER LA LAMPÉ UNIQUEMENT :**  
Appuyer sur le bouton pendant trois secondes. LE voyant DEL s'allume en rouge et la lampe s'éteint.

**RALLUMER LA LAMPÉ :**  
Éteindre l'interrupteur de la lampe qui se trouve sur la PLAQUE D'AIR. LE DEL s'éteint. Allumer l'interrupteur de la lampe.

**← INTERRUPTEUR DU CONTRÔLE D'ÉCLAIRAGE**

MODEL SERIAL NO. \_\_\_\_\_

<p><b>⚠ DANGER</b></p> <p><b>GloBug INFORMATION</b></p> <ul style="list-style-type: none"> <li>• To prevent creating NEVER touch lamp cables or cover while lamp is on.</li> <li>• These cables are extremely hot!</li> <li>• ALWAYS allow sufficient time for both surfaces to cool down before touching.</li> <li>• NEVER use on a surface of 5 degrees or more. The possibility of falling exists.</li> <li>• ALWAYS use a stand when using this machine.</li> <li>• ALWAYS use a stand when using this machine.</li> <li>• NEVER use the lighting system, system failure will occur.</li> </ul>	<p><b>⚠ WARNING</b></p> <p><b>INFORMATIONS GloBug</b></p> <ul style="list-style-type: none"> <li>• Pour éviter les brûlures, NE JAMAIS toucher les câbles ou le couvercle pendant que la lampe est allumée.</li> <li>• Ces câbles sont extrêmement chauds.</li> <li>• TOUJOURS attendre un temps suffisant pour que les deux surfaces se refroidissent avant de toucher.</li> <li>• NE JAMAIS utiliser sur une pente de 5 degrés ou plus. La possibilité de basculement existe.</li> <li>• TOUJOURS utiliser un stand lorsque vous utilisez cette machine.</li> <li>• NE JAMAIS utiliser un système d'éclairage sans utiliser le support.</li> <li>• NE JAMAIS utiliser le système d'éclairage sans utiliser le support.</li> </ul>	<p><b>⚠ DANGER</b></p> <p><b>AVERTISSEMENT</b></p> <ul style="list-style-type: none"> <li>• Pour éviter les brûlures, NE JAMAIS toucher les câbles ou le couvercle pendant que la lampe est allumée.</li> <li>• Ces câbles sont extrêmement chauds.</li> <li>• TOUJOURS attendre un temps suffisant pour que les deux surfaces se refroidissent avant de toucher.</li> <li>• NE JAMAIS utiliser sur une pente de 5 degrés ou plus. La possibilité de basculement existe.</li> <li>• TOUJOURS utiliser un stand lorsque vous utilisez cette machine.</li> <li>• NE JAMAIS utiliser un système d'éclairage sans utiliser le support.</li> <li>• NE JAMAIS utiliser le système d'éclairage sans utiliser le support.</li> </ul>	<p><b>⚠ AVERTISSEMENT</b></p> <p><b>INFORMATIONS GloBug</b></p> <ul style="list-style-type: none"> <li>• Pour éviter les brûlures, NE JAMAIS toucher les câbles ou le couvercle pendant que la lampe est allumée.</li> <li>• Ces câbles sont extrêmement chauds.</li> <li>• TOUJOURS attendre un temps suffisant pour que les deux surfaces se refroidissent avant de toucher.</li> <li>• NE JAMAIS utiliser sur une pente de 5 degrés ou plus. La possibilité de basculement existe.</li> <li>• TOUJOURS utiliser un stand lorsque vous utilisez cette machine.</li> <li>• NE JAMAIS utiliser un système d'éclairage sans utiliser le support.</li> <li>• NE JAMAIS utiliser le système d'éclairage sans utiliser le support.</li> </ul>
---	---	--	---

**⚠ ELECTRICAL SHOCK HAZARD**

NEVER operate any of the GloBug lighting systems while standing in water, with hands, wet hands, or wet, or in the rain unless a GFCI receptacle which is properly grounded.

Always use electrical shock risk prevention device before body touch or even death!

NEVER turn OFF generator before disconnecting AC power cable to generator.

**⚠ CAUTION**

• Do not touch the lamp while it is hot.

• Do not touch the lamp while it is hot.

• Do not touch the lamp while it is hot.

• Do not touch the lamp while it is hot.

• Do not touch the lamp while it is hot.

**⚠ RISK OF SHOCK / ÉLECTRIQUE**

NE JAMAIS utiliser aucun des systèmes d'éclairage GloBug debout dans l'eau, les pieds mouillés, ou sous la pluie, à moins d'utiliser un réceptacle GFCI qui est correctement mis à terre.

NE JAMAIS utiliser un système d'éclairage sans utiliser le support.

NE JAMAIS utiliser le système d'éclairage sans utiliser le support.

**⚠ ATTENTION**

NE JAMAIS utiliser aucun des systèmes d'éclairage GloBug debout dans l'eau, les pieds mouillés, ou sous la pluie, à moins d'utiliser un réceptacle GFCI qui est correctement mis à terre.

NE JAMAIS utiliser un système d'éclairage sans utiliser le support.

NE JAMAIS utiliser le système d'éclairage sans utiliser le support.

1

3

4

14

5

2

15

GB12BW-003

**⚠ DANGER**

NE JAMAIS utiliser sans avoir fermé le loquet. La possibilité de basculement est présente.

**⚠ DÉPLOYER L'ENSEMBLE DE DÉTAILS**

1. Déchirer la bande et tirer les pattes vers le bas au niveau de l'extrémité.
2. Soulever le mât pour attacher le loquet.

**⚠ RELÂCHER**

1. Soulever le mât et tirer la bande vers le haut pour déverrouiller le loquet.
2. Tirer la bande vers le haut tout en tenant la patte jusqu'à ce que les pattes soient mises en position de verrouillage.

**⚠ BANDE DOUÉE**

**ALWAYS hook the latch to prevent tipping.**

<p><b>⚠ DANGER</b></p> <p><b>ELECTRICAL SHOCK HAZARD</b></p> <p>When replacing lamp and to prevent electrical shock, ALWAYS shut down generator before replacing lamp. Remember to let lamp cool before removing.</p>	<p><b>⚠ WARNING</b></p> <p><b>HIGH VOLTAGE (E-BALLAST)</b></p> <p>The electronic components of the ballast generate high voltage. NEVER perform maintenance on the e-ballast when connected to a power source.</p>	<p><b>⚠ BURN HAZARD</b></p> <p>To prevent burns, NEVER touch lamp while lamp is on. Lamp surface gets extremely hot! ALWAYS allow sufficient time for lamp to cool down before touching.</p>	<p><b>⚠ AVERTISSEMENT</b></p> <p><b>RISQUE DE CHOC ÉLECTRIQUE</b></p> <p>Lors du remplacement de la lampe et pour éviter le risque de choc électrique, TOUJOURS éteindre le générateur avant de remplacer la lampe. Ne pas oublier de faire refroidir la lampe avant de la remplacer.</p>
<p><b>⚠ DANGER</b></p> <p><b>RISQUE DE CHOC ÉLECTRIQUE</b></p> <p>Lors du remplacement de la lampe et pour éviter le risque de choc électrique, TOUJOURS éteindre le générateur avant de remplacer la lampe. Ne pas oublier de faire refroidir la lampe avant de la remplacer.</p>	<p><b>⚠ HAUTE TENSION (E-BALLAST)</b></p> <p>Les composants électroniques du ballast génèrent une haute tension. NE JAMAIS effectuer l'entretien de l'e-ballast lorsqu'il est branché à une source d'alimentation.</p>	<p><b>⚠ AVERTISSEMENT</b></p> <p><b>RISQUE DE BRÛLURE</b></p> <p>Pour éviter les brûlures, NE JAMAIS toucher la lampe tant que celle-ci est allumée. La surface de la lampe devient extrêmement chaude! TOUJOURS permettre au lamp de se refroidir avant de la toucher.</p>	<p><b>⚠ AVERTISSEMENT</b></p> <p><b>RISQUE DE BRÛLURE</b></p> <p>Pour éviter les brûlures, NE JAMAIS toucher la lampe tant que celle-ci est allumée. La surface de la lampe devient extrêmement chaude! TOUJOURS permettre au lamp de se refroidir avant de la toucher.</p>

**⚠ CAUTION**

**LAMP INFORMATION**

NEVER allow the lamp to strike any hard surface. Excessive impact can cause damage and reduce the service life of the lamp.

**BALLOON INFORMATION**

NEVER use the lamp in the presence of balloons. The lamp surface when the lamp is hot, before using (GloBug ALWAYS use cover ballast) to prevent damage to balloons.

**⚠ CAUTION / ATTENTION**

• RELAMP WITH 400WATTS TYPE M59 METAL HALIDE.

• DO NOT INSTALL A LAMP IDENTIFIED FOR USE ONLY IN ENCLOSED LUMINAIRES.

• UTILISER UNE AMPOULE DE REMPLACEMENT DE 400W, TYPE M59 METAL HALIDE.

• NE PAS UTILISER UNE AMPOULE CONÇUE SEULEMENT POUR DES LUMINAIRES FERMÉS.

**⚠ ATTENTION**

**INFORMATIONS SUR LA LAMPÉ**

NE JAMAIS installer la lampe dans un luminaire fermé.

NE JAMAIS installer la lampe dans un luminaire fermé.

NE JAMAIS installer la lampe dans un luminaire fermé.

NE JAMAIS installer la lampe dans un luminaire fermé.

**⚠ CAUTION / ATTENTION**

• AC ONLY

• SUITABLE FOR WET LOCATIONS

• G.A. SEULEMENT

• CONVIENT AUX EMPLOIS EN MOULÉES

11

8

10

16

9

13

## NAMEPLATE AND DECALS (GB12BW)

<u>NO.</u>	<u>PART NO.</u>	<u>PART NAME</u>	<u>QTY.</u>	<u>REMARKS</u>
1	A400324800	DECAL; GLOBUG INFORMATION, ELECTRIC SHOCK	1	
2	A400166701	DECAL; LATCH, RIGHT	1	
3	A400324100	DECAL; LATCH, LEFT	1	
4	A400194100	DECAL; DANGER, WORKSTAND DEPLOYMENT (ENGLISH)	1	
5	A400324300	DECAL; DANGER, WORKSTAND DEPLOYMENT (FRENCH)	1	
6	A400326300	DECAL; CAUTION, LAMP TYPE	1	
7	A400290900	DECAL; CAUTION, LAMP INFORMATION (ENGLISH)	1	
8	A400324200	DECAL; CAUTION, LAMP INFORMATION (FRENCH)	1	
9	A400084300	DECAL; GROUND	2	
10	A400323900	DECAL; LIGHT CONTROL SWITCH	1	
11	A400325000	DECAL; CAUTION, AC ONLY	1	
12	A400325100	DECAL; ELECTRIC SHOCK, HIGH VOLTAGE, BURN HAZ.	1	
13	A400206000	DECAL; DIMMER SWITCH	1	
14	A400193300	DECAL; GLOBUG LIGHTING SYSTEM	1	
15	A400290801	DECAL; GB12BW-003	1	
16		NAMEPLATE.....	1	..... CONTACT MQ PARTS

# NAMEPLATE AND DECALS (GB12BS)

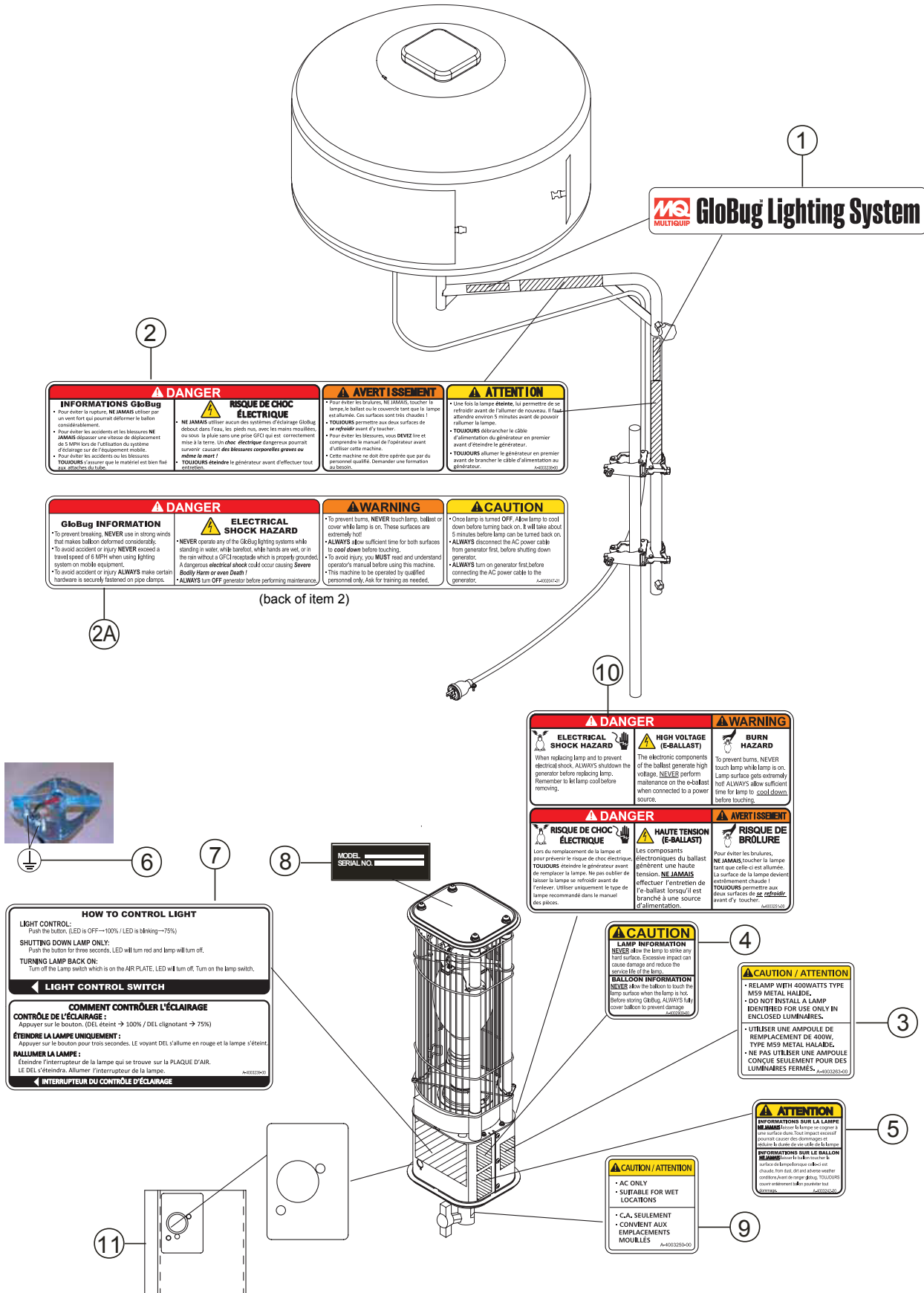

**1**

<p><b>INFORMATIONS GloBug</b></p> <ul style="list-style-type: none"> <li>• Pour éviter les blessures, NE JAMAIS utiliser par un vent fort qui pourrait déformer le ballon considérablement.</li> <li>• Pour éviter les accidents et les blessures NE JAMAIS dépasser une vitesse de déplacement de 5 MPH lors de l'utilisation du système d'éclairage sur de l'équipement mobile.</li> <li>• Pour éviter les accidents ou les blessures TOUJOURS s'assurer que le matériel est bien fixé aux attaches du tube.</li> </ul>	<p><b>⚠ DANGER</b></p> <p><b>RISQUE DE CHOC ÉLECTRIQUE</b></p> <ul style="list-style-type: none"> <li>• NE JAMAIS utiliser aucun des systèmes d'éclairage GloBug debout dans l'eau, les pieds nus, avec les mains mouillées, ou sous la pluie sans une prise GFCI qui est correctement mise à terre. Un choc électrique dangereux pourrait survenir causant des blessures graves ou même la mort!</li> <li>• TOUJOURS éteindre le générateur avant d'effectuer tout entretien.</li> </ul>	<p><b>⚠ AVERTISSEMENT</b></p> <ul style="list-style-type: none"> <li>• Pour éviter les blessures, NE TOUJOURS toucher la lampe, le ballast ou le couvercle tant que la lampe est allumée. Ces surfaces sont très chaudes!</li> <li>• TOUJOURS permettre aux deux surfaces de se refroidir avant d'y toucher.</li> <li>• Pour éviter les blessures, vous DEVEZ lire et comprendre le manuel de l'opérateur avant d'utiliser cette machine.</li> <li>• Cette machine ne doit être opérée que par du personnel qualifié. Demander une formation au besoin.</li> </ul>	<p><b>⚠ ATTENTION</b></p> <ul style="list-style-type: none"> <li>• Une fois la lampe éteinte, il peut prendre de se refroidir avant de l'allumer de nouveau. Il faut attendre environ 5 minutes avant de pouvoir rallumer la lampe.</li> <li>• TOUJOURS débrancher le câble d'alimentation du générateur en premier avant d'éteindre le générateur.</li> <li>• TOUJOURS allumer le générateur en premier avant de brancher le câble d'alimentation au générateur.</li> </ul>
---	---	--	--

**2**

<p><b>⚠ DANGER</b></p> <p><b>GloBug INFORMATION</b></p> <ul style="list-style-type: none"> <li>• To prevent blowing, NEVER use in strong winds that makes balloon deformed considerably.</li> <li>• To avoid accident or injury NEVER exceed a travel speed of 5 MPH when using lighting system on mobile equipment.</li> <li>• To avoid accident or injury ALWAYS make certain hardware is securely fastened on pipe clamps.</li> </ul>	<p><b>⚠ DANGER</b></p> <p><b>ELECTRICAL SHOCK HAZARD</b></p> <ul style="list-style-type: none"> <li>• NEVER operate any of the GloBug lighting systems while standing in water, while barefoot, while hands are wet, or in the rain without a GFCI receptacle which is properly grounded. A dangerous electrical shock could occur causing Severe Bodily Harm or even Death!</li> <li>• ALWAYS turn OFF generator before performing maintenance.</li> </ul>	<p><b>⚠ WARNING</b></p> <p><b>AVERTISSEMENT</b></p> <ul style="list-style-type: none"> <li>• To prevent burns, NEVER touch lamp, ballast or cover while lamp is on. These surfaces are extremely hot!</li> <li>• ALWAYS allow sufficient time for both surfaces to cool down before touching.</li> <li>• To avoid injury, you MUST read and understand operator's manual before using this machine.</li> <li>• This machine to be operated by qualified personnel only. Ask for training as needed.</li> </ul>	<p><b>⚠ CAUTION</b></p> <ul style="list-style-type: none"> <li>• Once lamp is turned OFF, Allow lamp to cool down before turning back on. It will take about 5 minutes before lamp can be turned back on.</li> <li>• ALWAYS disconnect the AC power cable from generator first, before shutting down generator.</li> <li>• ALWAYS turn on generator first before connecting the AC power cable to the generator.</li> </ul>
--	---	--	---

(back of item 2)

**2A**



**10**

<p><b>⚠ DANGER</b></p> <p><b>ELECTRICAL SHOCK HAZARD</b></p> <p>When replacing lamp and to prevent electrical shock, ALWAYS shutdown the generator before replacing lamp. Remember to let lamp cool before removing.</p>	<p><b>⚠ WARNING</b></p> <p><b>HIGH VOLTAGE (E-BALLAST)</b></p> <p>The electronic components of the ballast generate high voltage. NEVER perform maintenance on the e-ballast when connected to a power source.</p>	<p><b>⚠ WARNING</b></p> <p><b>BURN HAZARD</b></p> <p>To prevent burns, NEVER touch lamp while lamp is on. Lamp surface gets extremely hot! ALWAYS allow sufficient time for lamp to cool down before touching.</p>
<p><b>⚠ DANGER</b></p> <p><b>RISQUE DE CHOC ÉLECTRIQUE</b></p> <p>Lors du remplacement de la lampe et pour prévenir le risque de choc électrique, TOUJOURS éteindre le générateur avant de remplacer la lampe. Ne pas oublier de laisser la lampe se refroidir avant de l'enlever. Utiliser uniquement le type de lampe recommandé dans le manuel des pièces.</p>	<p><b>⚠ AVERTISSEMENT</b></p> <p><b>HAUTE TENSION (E-BALLAST)</b></p> <p>Les composants électroniques du ballast génèrent une haute tension, NE JAMAIS effectuer l'entretien de l'e-ballast lorsqu'il est branché à une source d'alimentation.</p>	<p><b>⚠ AVERTISSEMENT</b></p> <p><b>RISQUE DE BRÛLURE</b></p> <p>Pour éviter les brûlures, NE JAMAIS toucher la lampe tant que celle-ci est allumée. La surface de la lampe devient extrêmement chaude! TOUJOURS permettre aux deux surfaces de se refroidir avant d'y toucher.</p>

**6**

**7**

**8**

**MODEL SERIAL NO**

**HOW TO CONTROL LIGHT**

**LIGHT CONTROL:**  
Push the button, (LED is OFF—100%, LED is blinking—75%)

**SHUTTING DOWN LAMP ONLY:**  
Push the button for three seconds, LED will turn red and lamp will turn off.

**TURNING LAMP BACK ON:**  
Turn off the Lamp switch which is on the AIR PLATE, LED will turn off, Turn on the lamp switch,

**← LIGHT CONTROL SWITCH**

**COMMENT CONTRÔLER L'ÉCLAIRAGE**

**CONTRÔLE DE L'ÉCLAIRAGE :**  
Appuyer sur le bouton, (DEL éteint → 100% / DEL clignotant → 75%)

**ÉTEINDRE LA LAMPE UNIQUEMENT :**  
Appuyer sur le bouton pour trois secondes, LE voyant DEL s'allume en rouge et la lampe s'éteint.

**RALLUMER LA LAMPE :**  
Éteindre l'interrupteur de la lampe qui se trouve sur la PLAQUE D'AIR, LE DEL s'éteint. Allumer l'interrupteur de la lampe.

**← INTERRUPTEUR DU CONTRÔLE D'ÉCLAIRAGE**

**4**

**⚠ CAUTION**

**LAMP INFORMATION**

NEVER allow the lamp to strike any hard surface. Excessive impact can cause damage and reduce the service life of the lamp.

**BALLOON INFORMATION**

NEVER allow the balloon to touch the lamp surface when the lamp is hot. Before storing GloBug, ALWAYS lay over balloon to prevent damage.

**3**

**⚠ CAUTION / ATTENTION**

- RELAMP WITH 40WATTS TYPE MS5 METAL HALIDE.
- DO NOT INSTALL A LAMP IDENTIFIERS FOR USE ONLY IN ENCLOSED LUMINAIRES.
- UTILISER UNE AMPOULE DE REMPLACEMENT DE 400W, TYPE MS5 METAL HALIDE.
- NE PAS UTILISER UNE AMPOULE CONÇUE SEULEMENT POUR DES LUMINAIRES FERMÉS.

**5**

**⚠ ATTENTION**

**INFORMATIONS SUR LA LAMPE**

NE JAMAIS laisser la lampe en contact avec une surface dure. Tout impact excessif pourrait causer des dommages et réduire la durée de vie utile de la lampe.

**INFORMATIONS SUR LE BALLON**

NE JAMAIS laisser le ballon toucher la surface de la lampe lorsque celle-ci est chaude. Avant de ranger GloBug, TOUJOURS couvrir le ballon avec le ballon protecteur.

**9**

**⚠ CAUTION / ATTENTION**

- AC ONLY
- SUITABLE FOR WET LOCATIONS
- C.A. SEULEMENT
- CONVIENT AUX EMPLOIEMENTS MOULLES

**11**

## NAMEPLATE AND DECALS (GB12BS)

<u>NO.</u>	<u>PART NO.</u>	<u>PART NAME</u>	<u>QTY.</u>	<u>REMARKS</u>
1	A400193300	DECAL; GLOBUG LIGHTING SYSTEM	1	
2	A400323800	DECAL; GLOBUG INFO, ELECTRIC SHOCK(FRENCH)	1	
2A	A400204701	DECAL; GLOBUG INFO, ELECTRIC SHOCK(ENGLISH)	1	
3	A400326300	DECAL; LAMP TYPE	1	
4	A400290900	DECAL; CAUTION, LAMP INFORMATION (ENGLISH)	1	
5	A400324200	DECAL; CAUTION, LAMP INFORMATION (FRENCH)	1	
6	A400084300	DECAL; GROUND	2	
7	A400323900	DECAL; LIGHT CONTROL SWITCH	1	
8		NAMEPLATE.....	1	.... CONTACT MQ PARTS DEPT.
9	A400325000	DECAL; CAUTION, AC ONLY	1	
10	A400325100	DECAL; ELECTRIC SHOCK, HIGH VOLTAGE, BURN HAZ.	1	
11	A400206000	DECAL; DIMMER SWITCH	1	

# NAMEPLATE AND DECALS (GB12BP)

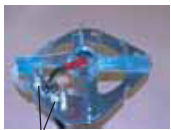

**HOW TO CONTROL LIGHT**

**LIGHT CONTROL:**  
Push the button. (LED is OFF—100% / LED is blinking—75%)

**SHUTTING DOWN LAMP ONLY:**  
Push the button for three seconds. LED will turn red and lamp will turn off.

**TURNING LAMP BACK ON:**  
Turn off the Lamp switch which is on the AIR PLATE. LED will turn off. Turn on the lamp switch.

**← LIGHT CONTROL SWITCH**

---

**COMMENT CONTRÔLER L'ÉCLAIRAGE**

**CONTRÔLE DE L'ÉCLAIRAGE:**  
Appuyer sur le bouton. (DEL éteint → 100% / DEL clignotant → 75%)

**ÉTEINDRE LA LAMPE UNIQUEMENT:**  
Appuyer sur le bouton pour trois secondes. LE voyant DEL s'allume en rouge et la lampe s'éteint.

**RALLUMER LA LAMPE:**  
Éteindre l'interrupteur de la lampe qui se trouve sur la PLAQUE D'AIR. LE DEL s'éteindra. Allumer l'interrupteur de la lampe.

**← INTERRUPTEUR DU CONTRÔLE D'ÉCLAIRAGE**

A40032940

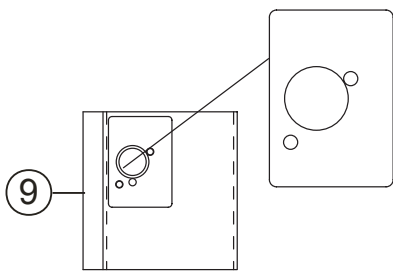

**12**

<b>⚠ DANGER</b> <b>ELECTRICAL SHOCK HAZARD</b> When replacing lamp and to prevent electrical shock, ALWAYS shutdown the generator before replacing lamp. Remember to let lamp cool before removing.	<b>⚠ HIGH VOLTAGE (E-BALLAST)</b> The electronic components of the ballast generate high voltage. NEVER perform maintenance on the e-ballast when connected to a power source.	<b>⚠ WARNING</b> <b>BURN HAZARD</b> To prevent burns, NEVER touch lamp while lamp is on. Lamp surface gets extremely hot ALWAYS allow sufficient time for lamp to cool down before touching.
<b>⚠ RISQUE DE CHOC ÉLECTRIQUE</b> Lors du remplacement de la lampe et pour prévenir le risque de choc électrique, TOUJOURS éteindre le générateur avant de remplacer la lampe. Ne pas oublier de laisser la lampe se refroidir avant de l'enlever. Utiliser uniquement le type de lampe recommandé dans le manuel des pièces.	<b>⚠ HAUTE TENSION (E-BALLAST)</b> Les composants électroniques du ballast génèrent une haute tension. NE JAMAIS effectuer l'entretien de l'e-ballast lorsqu'il est branché à une source d'alimentation.	<b>⚠ AVERTISSEMENT</b> <b>RISQUE DE BRÛLURE</b> Pour éviter les brûlures, NE JAMAIS toucher la lampe tant que celle-ci est allumée. La surface de la lampe devient extrêmement chaude. TOUJOURS permettre aux deux surfaces de se refroidir avant d'y toucher.

**2**

**⚠ CAUTION**

**LAMP INFORMATION**  
NEVER allow the lamp to settle any hard surface. Excessive impact can cause damage and reduce the service life of the lamp.

**BALLOON INFORMATION**  
NEVER allow the balloon to touch the lamp surface when the lamp is hot. Before storing GlobBug, ALWAYS fully cover balloon to prevent damage.

**1**

**⚠ CAUTION / ATTENTION**

- RELAMP WITH 400WATTS TYPE MS9 METAL HALIDE.
- DO NOT INSTALL A LAMP IDENTIFIED FOR USE ONLY IN ENCLOSED LUMINAIRES.
- UTILISER UNE AMPOULE DE REMPLACEMENT DE 400W, TYPE MS9 METAL HALAIDE.
- NE PAS UTILISER UNE AMPOULE CONÇUE SEULEMENT POUR DES LUMINAIRES FERMÉS.

A400329340

**3**

**⚠ ATTENTION**

**INFORMATIONS SUR LA LAMPE**  
NE JAMAIS laisser la lampe se cogner à une surface dure. Tout impact excessif pourrait causer des dommages et réduire la durée de vie de la lampe.

**INFORMATIONS SUR LE BALLON**  
NE JAMAIS laisser le ballon toucher la surface de la lampe lorsque celle-ci est chaude. Avant de ranger GlobBug, TOUJOURS couvrir entièrement le ballon pour éviter les dommages.

**11**

**⚠ CAUTION / ATTENTION**

- AC ONLY
- SUITABLE FOR WET LOCATIONS
- C.A. SEULEMENT
- CONVIENT AUX EMBLEMES MOUILLES

A4003295000

## NAMEPLATE AND DECALS (GB12BP)

<u>NO.</u>	<u>PART NO.</u>	<u>PART NAME</u>	<u>QTY.</u>	<u>REMARKS</u>
1	A400326300	DECAL; LAMP TYPE	1	
2	A400290900	DECAL; CAUTION, LAMP INFORMATION (ENGLISH)	1	
3	A400324200	DECAL; CAUTION, LAMP INFORMATION (FRENCH)	1	
4	A400084300	DECAL; GROUND	2	
5	A400323900	DECAL; LIGHT CONTROL SWITCH	1	
6		NAMEPLATE.....	1	.... CONTACT MQ PARTS DEPT.
7	A400325000	DECAL; CAUTION, AC ONLY	1	
8	A400325100	DECAL; ELECTRIC SHOCK, HIGH VOLTAGE, BURN HAZ.	1	
9	A400206000	DECAL; DIMMER SWITCH	1	

# MAST/TRIPOD ASSY.

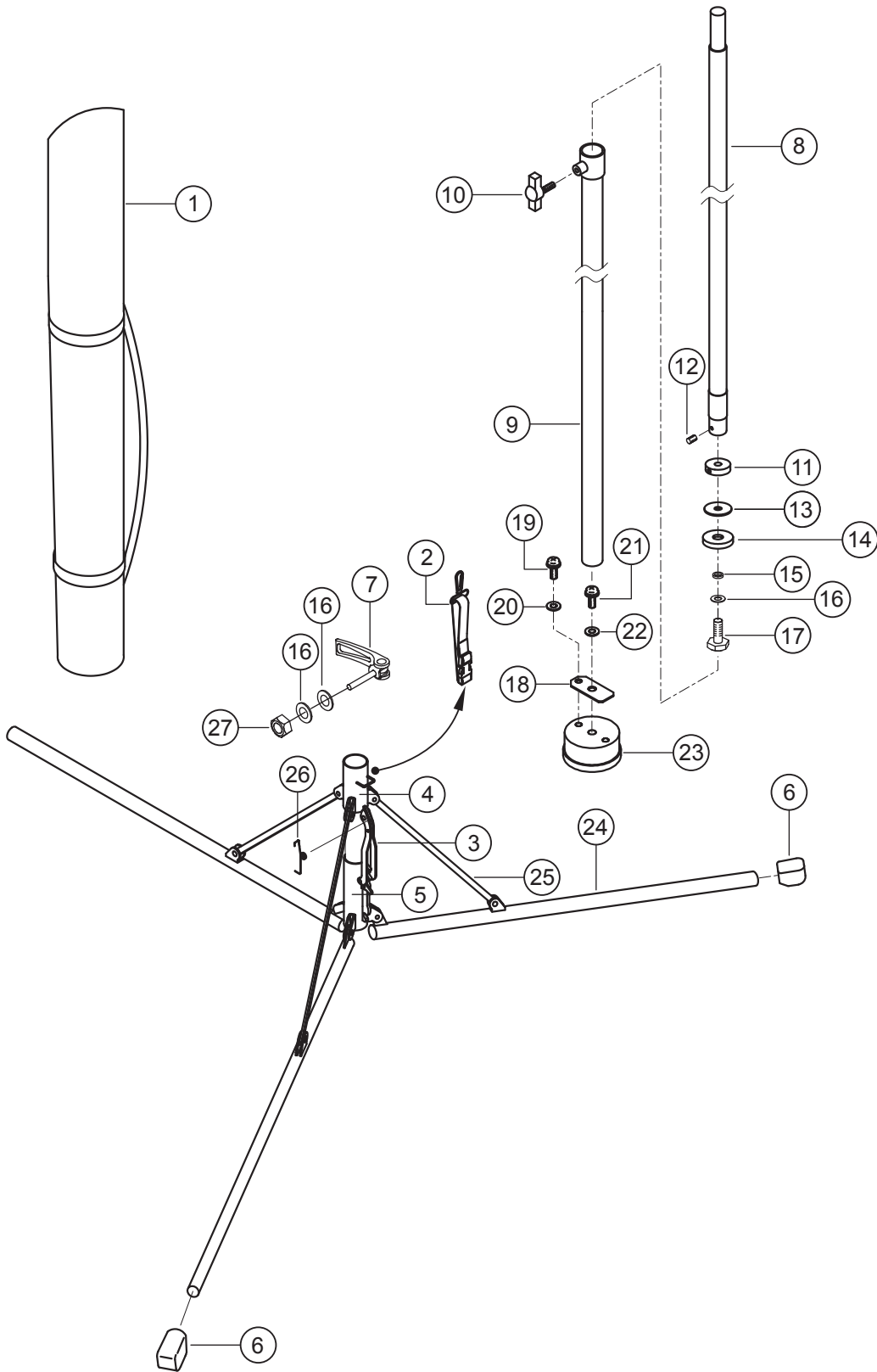



## MAST/TRIPOD ASSY.

<u>NO.</u>	<u>PART NO.</u>	<u>PART NAME</u>	<u>QTY.</u>	<u>REMARKS</u>
1	A300131500	TRIPOD COVER	1	
2	A300106500	TRIPOD BAND	1	
3	A300108700	SHACKLE CP	1	
4	A300199600	BASE PIPE 2	1	
5	A300199500	BASE PIPE 1	1	
6	1641000330	RUBBER FOOT	3	
7	2212780310	LEVER	1	
8	A300200600	SECOND MAST ASSY	1	
9	A300200300	FIRST MAST ASSY	1	
10	A400187600	KNOB	1	
11	A400229900	BOTTOM PLATE	1	
12	0024705008	SET SCREW, M5x8	2	
13	A400200500	WASHER, SECOND MAST	1	
14	A400200700	RUBBER, MAST	1	
15	A400110200	WASHER, MAST	1	
16	0043108000	WASHER, M8	3	
17	0013108030	BOLT, M8x30	1	
18	A400112700	LEAF VALVE	1	
19	0023104008	SCREW, M4x8	1	
20	0043104000	WASHER, M4	1	
21	0023105008	SCREW, M5x8	1	
22	0043105000	WASHER, M5	1	
23	A400199700	PLUG	1	
24	A300171601	PIPE, BASE	3	
25	A300113103	STAY	3	
26	A400205901	SPRING, SHACKLE	1	
27	0033206000	SELFLOCK NUT, M8	1	

# FAN BLOWER/LAMP ASSY.

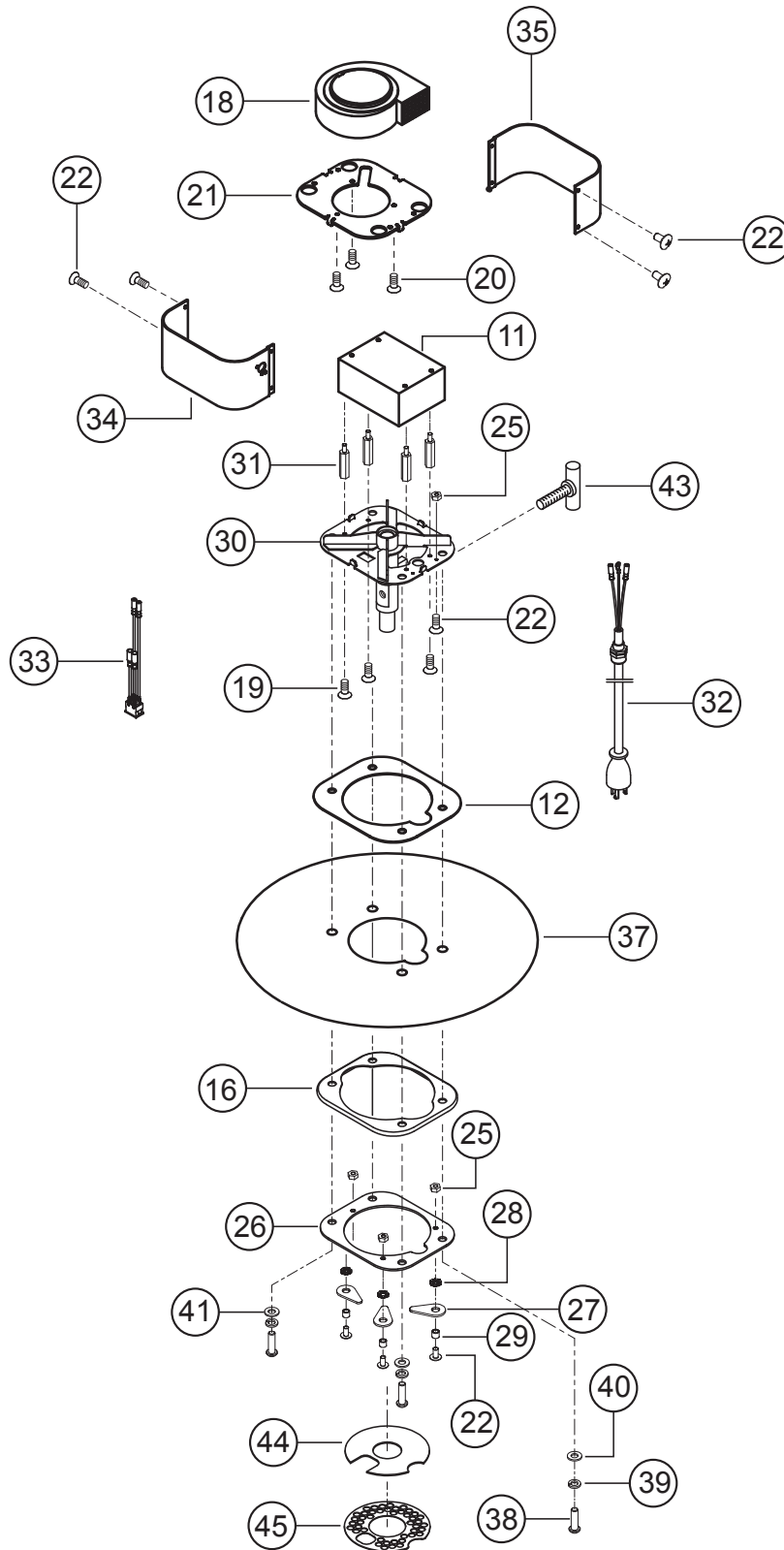

## FAN BLOWER/LAMP ASSY.

<u>NO.</u>	<u>PART NO.</u>	<u>PART NAME</u>	<u>QTY.</u>	<u>REMARKS</u>
11	A300275800	ELE-BALLAST ASSY	1	
12	2214500230	SEAL, FLAT	1	
16	A300162400	SEAL, PACKING	1	
18	A300264500	FAN MOTOR ASSY	1	
19	0023304012	SCREW & WASHER, M4x12	4	
20	0023204006	SCREW, M4x6	3	
21	A300164900	PLATE, FAN	1	
22	0024304008	SCREW, M4x8	9	
25	0033104000	NUT, M4	5	
26	A300145801	PLATE, BOTTOM	1	
27	A400030700	STOPPER, FILTER	3	
28	E000119300	WAVE WASHER, M6	3	
29	E000077500	SPACER	3	
30	A200057603	FLANGE	1	
31	E000114400	SPACER	4	
32	A300181901	POWER CABLE	1	
33	A300269500	SWITCH CP	1	
34	A300180500	VESSEL 1	1	
35	A300180600	VESSEL 2	1	
37	A300148200	SHEET, BOTTOM	1	
38	0014710035	BUTTON SCREW, M10x35	4	
39	0043210000	SPRING WASHER, M10	8	
40	2204510110	WASHER	1	
41	0043110000	WASHER, M10	3	
43	A400209801	KNOB, KSM-50-M10x30	1	
44	A300174401	FILTER	1	
45	A300175300	PLATE, AIR	1	

# BALLOON/LAMP GUARD ASSY.

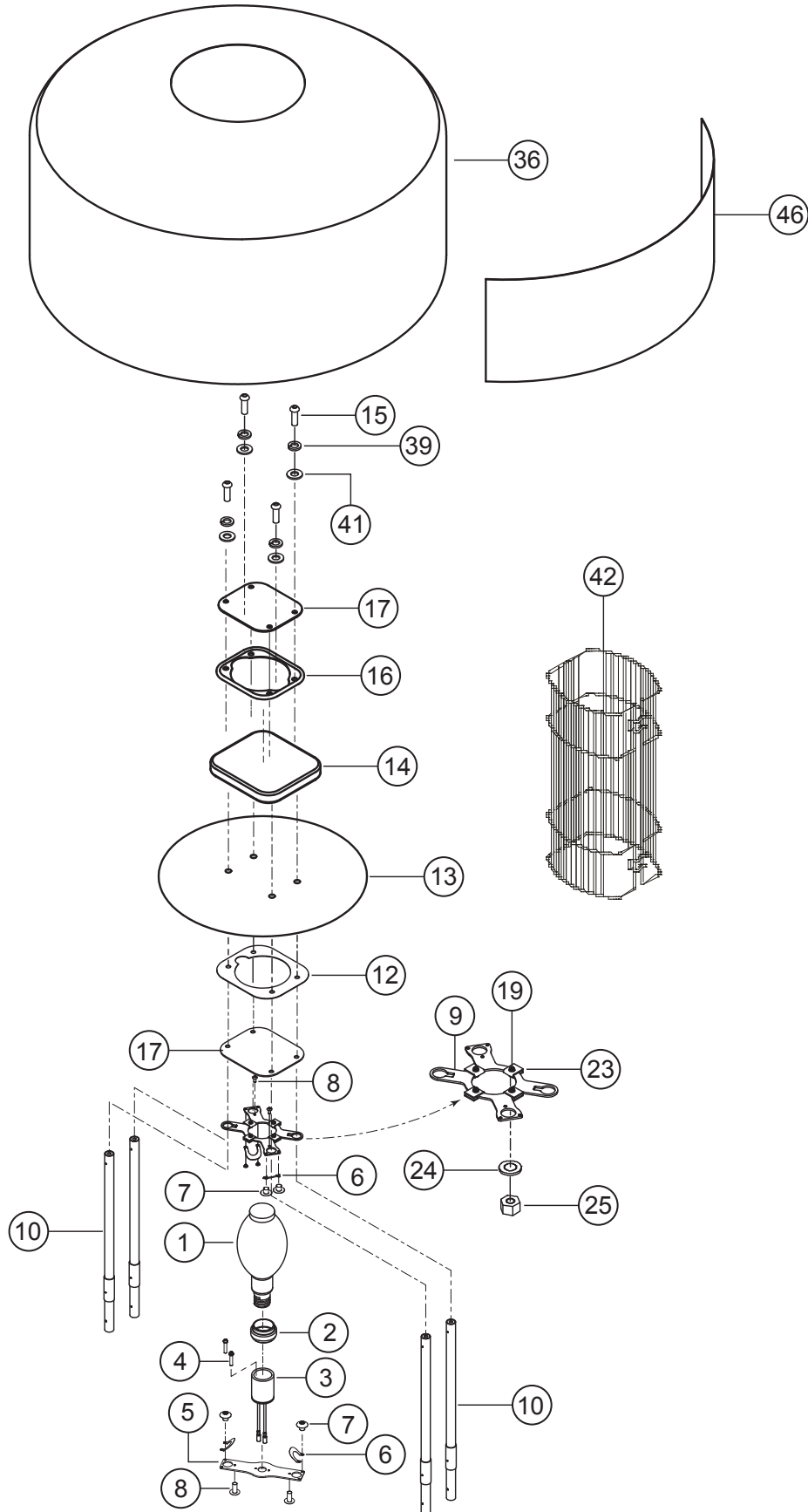

## BALLOON/LAMP GUARD ASSY.

---

<u>NO.</u>	<u>PART NO.</u>	<u>PART NAME</u>	<u>QTY.</u>	<u>REMARKS</u>
1	E000125500	LAMP, MP400	1	
2	E000038200	RUBBER	1	
3	A300273200	SOCKET ASSY	1	
4	0023304015	SCREW AND WASHER, M4x15	2	
5	A300160602	PLATE, LAMP	1	
6	A400195200	STOPPER	4	
7	0024304004	SCREW, M4x4	8	
8	0023405012	SCREW, M5x12	4	
9	A300174000	LAMP HOLDER	1	
10	A300171902	MAIN POLE	4	
12	2214500230	SEAL, FLAT	1	
13	A300160301	SHEET, TOP	1	
14	A100048003	BALLOON COVER	1	
15	0014710025	BUTTON SCREW, M10x25	4	
16	A300162400	SEAL, PACKING	1	
17	A300165100	PLATE, TOP	2	
19	0023304012	SCREW AND WASHER, M4x12	4	
23	A400199500	PACKING, LAMP	4	
24	0043104000	WASHER, M4	4	
25	0033104000	NUT, M4	4	
36	A100015901	BALLOON CLOTH	1	
39	0043210000	SPRING WASHER, M10	8	
41	0043110000	WASHER, M10	4	
42	A100061300	LAMP GUARD	1	
46	A300067700	BLANK MESSAGE STRIP	1	

# OFFSET POLE ASSY. (GB12BS)

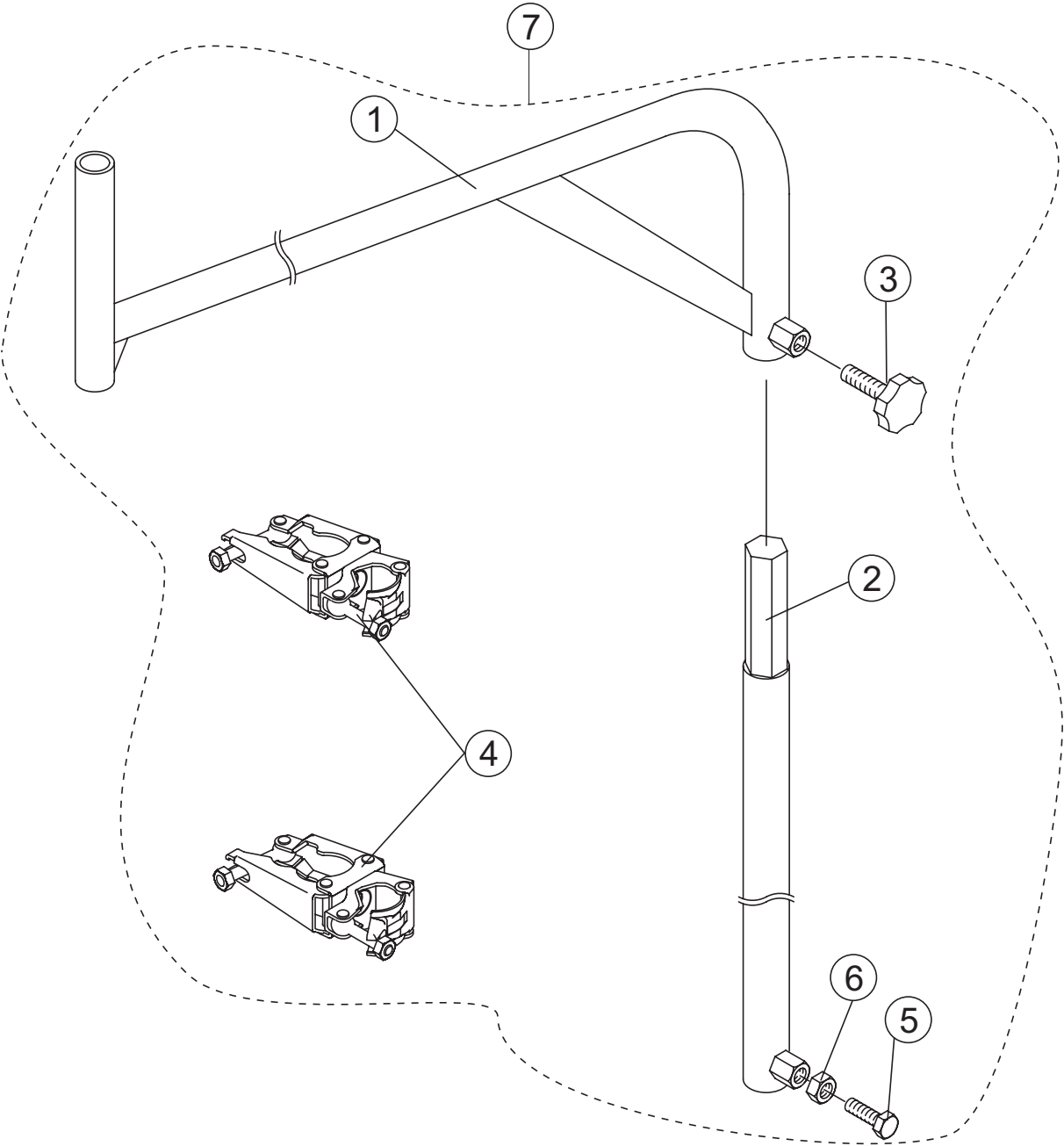

## OFFSET POLE ASSY. (GB12BS)

---

<u>NO.</u>	<u>PART NO.</u>	<u>PART NAME</u>	<u>QTY.</u>	<u>REMARKS</u>
1#	A200056702	OFFSET POLE	1	
2#	A300166600	POLE	1	
3#	E000077100	KNOB	1	
4#	E000093401	CLAMP	2	
5#	0013112040	BOLT, M12x40	1	
6#	0033112000	NUT, M12	1	
7	A000028100	POLE MOUNT KIT.....	1.....	INCLUDES ITEMS W/ # CONTACT MQ UNIT SALES

# OPERATION AND PARTS MANUAL

## HERE'S HOW TO GET HELP

PLEASE HAVE THE MODEL AND SERIAL  
NUMBER ON-HAND WHEN CALLING

### UNITED STATES

#### *Multiquip Inc.*

(310) 537- 3700  
6141 Katella Avenue Suite 200  
Cypress, CA 90630  
E-MAIL: [mq@multiquip.com](mailto:mq@multiquip.com)  
WEBSITE: [www.multiquip.com](http://www.multiquip.com)

---

### CANADA

#### *Multiquip*

(450) 625-2244  
4110 Industriel Boul.  
Laval, Quebec, Canada H7L 6V3  
E-MAIL: [infocanada@multiquip.com](mailto:infocanada@multiquip.com)

### UNITED KINGDOM

#### *Multiquip (UK) Limited Head Office*

0161 339 2223  
Unit 2, Northpoint Industrial Estate,  
Globe Lane,  
Dukinfield, Cheshire SK16 4UJ  
E-MAIL: [sales@multiquip.co.uk](mailto:sales@multiquip.co.uk)

© COPYRIGHT 2019, MULTIQUIP INC.

Multiquip Inc, the MQ logo are registered trademarks of Multiquip Inc. and may not be used, reproduced, or altered without written permission. All other trademarks are the property of their respective owners and used with permission.

This manual MUST accompany the equipment at all times. This manual is considered a permanent part of the equipment and should remain with the unit if resold.

The information and specifications included in this publication were in effect at the time of approval for printing. Illustrations, descriptions, references and technical data contained in this manual are for guidance only and may not be considered as binding. Multiquip Inc. reserves the right to discontinue or change specifications, design or the information published in this publication at any time without notice and without incurring any obligations.

