

OPERATION AND PARTS MANUAL



GloBug **MODELS GB12BW/BS/BP** **LIGHTING SYSTEM**

Revision #2 (11/03/08)

To find the latest revision of this
publication, visit our website at:
www.multiquip.com



THIS MANUAL MUST ACCOMPANY THE EQUIPMENT AT ALL TIMES.

TABLE OF CONTENTS

MQ GLOBUG LIGHTING SYSTEM

Table Of Contents	2
Parts Ordering Procedures	3
Safety Message Alert Symbols	4
Rules For Safe Operation	5-7
Specifications	8
Dimensions (GB12BW)	9
Dimensions (GB12BS)	10
Dimensions (GB12BP)	11
Floodlight Footcandle Plot	12
General Information	13
Major Components	14-15
Setup (GB12BW)	16-18
Operation (GB12BW)	19
Shutdown (GB12BW/GB12BS)	19
Storage (GB12BW/GB12BS)	19
Setup (GB12BS)	21-22
Operation (GB12BS)	23
Maintenance	24-29
Troubleshooting (Lamps)	30
Troubleshooting (Mast)	31
Explanation Of Codes In Remarks Column	32
Suggested Spare Parts	33

COMPONENT DRAWINGS

Nameplate and Decals Assembly	34-35
Mast/Tripod Assembly (GB12BW)	36-37
Fan Blower/Lamp Base Assembly (GB12BP)	38-39
Balloon/Lamp Guard Assembly (GB12BP)	40-41
Offset Pole Assembly (GB12BS)	42-43
Terms and Conditions Of Sale — Parts	50

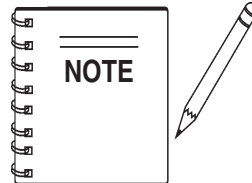

Specification and part number are subject to change without notice.

www.multiquip.com

**Ordering parts has never been easier!
Choose from three easy options:**



Order via Internet (Dealers Only):

Order parts on-line using Multiquip's SmartEquip website!

- View Parts Diagrams
- Order Parts
- Print Specification Information



If you have an MQ Account, to obtain a Username and Password, E-mail us at: parts@multiquip.com.

To obtain an MQ Account, contact your District Sales Manager for more information.

Goto www.multiquip.com and click on **Order Parts** to log in and save!

Use the **internet** and qualify for a **5% Discount** on *Standard orders* for all orders which include complete part numbers.*

Note: Discounts Are Subject To Change



Order via Fax (Dealers Only):

All customers are welcome to order parts via Fax.

Domestic (US) Customers dial:
1-800-6-PARTS-7 (800-672-7877)

Fax your order in and qualify for a **2% Discount** on *Standard orders* for all orders which include complete part numbers.*

Note: Discounts Are Subject To Change



Order via Phone: Domestic (US) Dealers Call:
1-800-427-1244

Non-Dealer Customers:

Contact your local Multiquip Dealer for parts or call 800-427-1244 for help in locating a dealer near you.



International Customers should contact their local Multiquip Representatives for Parts Ordering information.

When ordering parts, please supply:

- | | |
|---|--|
| <input type="checkbox"/> Dealer Account Number | <input type="checkbox"/> Specify Preferred Method of Shipment: |
| <input type="checkbox"/> Dealer Name and Address | <input checked="" type="checkbox"/> UPS/Fed Ex <input checked="" type="checkbox"/> DHL |
| <input type="checkbox"/> Shipping Address (if different than billing address) | <input type="checkbox"/> Priority One <input checked="" type="checkbox"/> Truck |
| <input type="checkbox"/> Return Fax Number | <input type="checkbox"/> Ground |
| <input type="checkbox"/> Applicable Model Number | <input type="checkbox"/> Next Day |
| <input type="checkbox"/> Quantity, Part Number and Description of Each Part | <input type="checkbox"/> Second/Third Day |

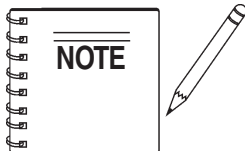

All orders are treated as *Standard Orders* and will ship the same day if received prior to 3PM PST.

WE ACCEPT ALL MAJOR CREDIT CARDS!



GB12BW/BS/BP LIGHTING SYSTEM — SAFETY MESSAGE ALERT SYMBOLS

FOR YOUR SAFETY AND THE SAFETY OF OTHERS!

Safety precautions should be followed at all times when operating this equipment. Failure to read and understand the Safety Messages and Operating Instructions could result in injury to yourself and others.



Potential hazards associated with any of the *GloBug Lighting Systems* operation will be referenced with Hazard Symbols which appear throughout this manual, and will be referenced in conjunction with Safety Message Alert Symbols.

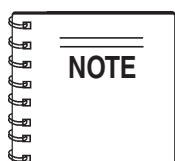

This Owner's Manual has been developed to provide complete instructions for the safe and efficient operation of the *MQ GloBug Lighting Systems*.

Before using any of the GloBug Lighting Systems referenced in this manual, ensure that the operating individual has read and understands all instructions in this manual.

CAUTION - Equipment Damage Messages

Other important messages are provided throughout this manual to help prevent damage to your lighting system, other property, or the surrounding environment.

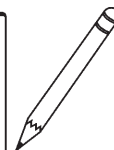
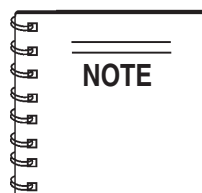

This lighting system, other property, or the surrounding environment could be damaged if you ***DO NOT*** follow instructions.

SAFETY MESSAGE ALERT SYMBOLS

The three (3) Safety Messages shown below will inform you about potential hazards that could injure you or others. The Safety Messages specifically address the level of exposure to the operator, and are preceded by one of three words: **DANGER**, **WARNING**, or **CAUTION**.

DANGER

You **WILL** be **KILLED** or **SERIOUSLY** injured if you **DO NOT** follow directions.

WARNING

You **CAN** be **KILLED** or **SERIOUSLY** injured if you **DO NOT** follow directions.

CAUTION

You **CAN** be **INJURED** if you **DO NOT** follow directions.

GB12BW/BS/BP LIGHTING SYSTEM — RULES FOR SAFE OPERATION



WARNING - READ THIS MANUAL

Failure to follow instructions in this manual may lead to **Serious Injury** or even **Death**. This equipment is to be operated by trained and qualified personnel only! This equipment is for industrial use only.

The following safety guidelines should always be used when operating GloBug Lighting System.

The following safety guidelines should always be used when operating any GloBug Lighting System:

GENERAL SAFETY

- **DO NOT** operate or service this equipment before reading this entire manual.
- This equipment should not be operated by persons under 18 years of age.
- **NEVER** operate this equipment without proper protective clothing, shatterproof glasses, steel-toed boots and other protective devices required by the job.



- **NEVER** operate this equipment when not feeling well due to fatigue, illness or taking medicine. 
- **NEVER** operate this equipment under the influence of **drugs** or **alcohol**.



- Whenever necessary, replace nameplate, operation and safety decals when they become difficult to read.
- Manufacturer does not assume responsibility for any accident due to equipment modifications.
- **NEVER** use accessories or attachments, which are not recommended by Multiquip for this equipment. Damage to the equipment and/or injury to user may result.

- **ALWAYS** make sure that the GB12BW (tripod) lighting system is placed on secure firm level ground so that it cannot slide or shift around, endangering workers. Also keep the immediate area free of bystanders.
- **ALWAYS** keep area behind lighting system clear of people while raising and lowering mast.
- To prevent the lighting system from overturning, **NEVER** use in winds that exceed 22 mph (10m/s).
- To prevent the GB12BW (tripod) lighting system from tipping, **ALWAYS** place tripod on a firm flat surface. Surface slant should not exceed 5 degrees.
- The GloBug lighting system should only be used in temperatures between 23°-104° Fahrenheit (-5° to 40° Celsius). Failure to comply with these operating parameters could cause the lamp to malfunction and shorten the ballast life.
- **NEVER** use any GloBug lighting system in **rain, snow** or areas of high humidity that could generate electrical storms.

MAST SAFETY

- When raising or lowering the mast, keep hands and fingers clear of the various mast sections, this will prevent hands and fingers from getting pinched.

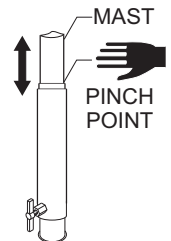

- **CHECK** the mast for any deformations. Replace mast if defective.
- **NEVER** attach anything to the mast.
- **ALWAYS** lower the mast when not in use, or if high winds or electrical storms are expected in the area.

GB12BW/BS/BP LIGHTING SYSTEM — RULES FOR SAFE OPERATION

- When transporting the tripod lighting system, always place tripod in the **stow position**, then place tripod into its carrying case.
- **ALWAYS** remove the balloon/lamp assembly from the mast when transporting any of the GloBug lighting systems. This will prevent damage to the bulb due to vibration.
- **NEVER** leave the balloon/lamp exposed during transport. Exposure to excess wind or rain could damage the balloon's nylon cover.
- **ALWAYS** place the balloon inside its protective cover during transport. Be sure the cover is secured tightly around the balloon/lamp assembly.

LAMP SAFETY AND CARE

- **NEVER** leave any grease or oil residue on lamp surface when replacing or removing lamp. This can create hot spots, reducing the service life of the lamp.
- **ALWAYS** make sure the lamp surface is clean and dry.
- **ALWAYS** replace with MQ recommended type lamp. See parts section of this manual.
- **NEVER** use force when installing the lamp. Excessive force could cause the lamp to break causing bodily harm.
- **ALWAYS** make sure the lamp guard is installed correctly. **NEVER** deform the lamp guard.
- **NEVER** attempt to replace lamp with the power on. Always unplug the power cord from the generator or power source when changing the lamp.
- **NEVER** unplug the lamp's AC power cable during operation.
- **ALWAYS** allow a sufficient amount of time for the lamp to **cool** before changing. The possibility exists of severe burns.
- **ALWAYS** have a **trained technician** to install and remove lamp, or replace any damaged fixture wiring.

BALLOON SAFETY AND CARE

- To prevent serious burns, **NEVER** touch or unzip the balloon envelope when the lamp is on.
- To prevent the balloon from deformation, **NEVER** use any GloBug lighting system in strong winds.
- **DO NOT** place the balloon inside its protective cover until the lamp has had a sufficient amount of time to cool down. This will prevent the balloon's nylon cover from being burned (touching the lamp surface).
- **ALWAYS** place the balloon inside its protective cover after each use. This will prolong the life of the balloon material, keeping it protected from harsh environmental elements.
- **DO NOT** use a damaged balloon. Replace balloon immediately if damaged. In addition, a damaged balloon will not inflate properly, and may become more damaged by touching the hot lamp surface.
- **ALWAYS** keep the balloon away from sharp objects and excessive amounts of heat (**fire!**).
- **DO NOT** use excessive force when zipping and unzipping the balloon. Be gentle with the zipper mechanism. If the zipper is broken the balloon will become unusable.

DANGER - Grounding

All GloBug lighting systems are equipped with a **ground pin on the power plug**. For your protection. **ALWAYS** complete the **grounding path**. **NEVER** insert the AC power plug into a 2-prong receptacle to operate any GloBug lighting system.



When applying power to the lighting system, always connect the AC power plug to a 3-prong receptacle that is grounded. The possibility exists of **Electrical Shock, Electrocutation, and even Death** if the lighting system is not grounded.

GB12BW/BS/BP LIGHTING SYSTEM — RULES FOR SAFE OPERATION

⚠ DANGER - Electric Shock Hazards

ALWAYS keep electrical cords in good condition. Worn, bare or frayed wiring can cause electrical shock, thus causing **Bodily Harm or even Death**.

NEVER grab or touch a live power cord with wet hands, the possibility exists of **Electrical Shock, Electrocutation, and even Death!**

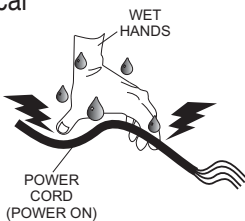

⚠ DANGER - Electric Shock Hazards

NEVER operate any of the GloBug lighting systems or handle any electrical equipment while standing in water, while barefoot, while hands are wet, or in the rain. A dangerous **electrical shock** could occur causing **Severe Bodily Harm or even Death**.

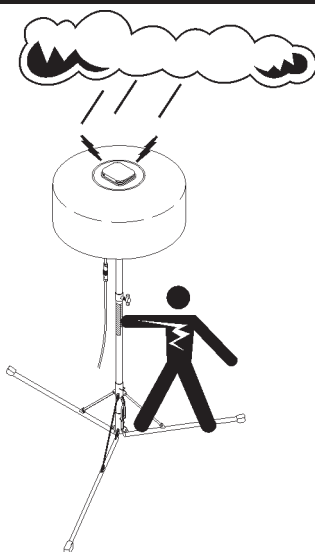

⚠ DANGER - Overhead Obstructions

ALWAYS make sure the area above any GloBug lighting system is open and clear of overhead power lines and other obstructions. The mast can extend in excess of 13 ft. (4 meters) when an optional extension pole is used. Contact with overhead power lines or other obstructions could result in electrical shock, electrocution, causing equipment damage, **Serious Injury or Death!**

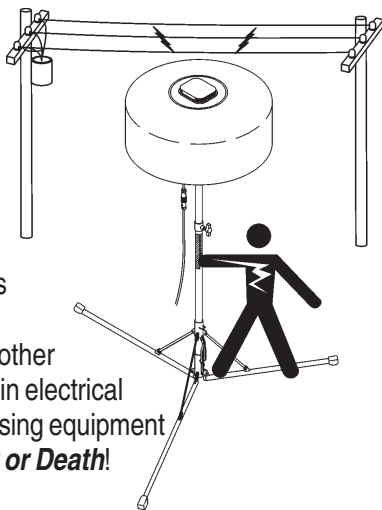

Maintenance Safety

- **NEVER** lubricate components or attempt service on any running GloBug lighting system.
- **ALWAYS** allow the GloBug lighting system a proper amount of time to cool before servicing.
- Keep all GloBug lighting systems in proper working condition.
- Fix damage to any GloBug lighting system immediately and always replace broken or defective parts.
- **ALWAYS** use the required tool for the job application. Using damaged or worn tools or using tools inappropriate for the required application is very dangerous, and may cause damage to the machine and service personnel. Make sure to use the appropriate tool for the specific job.

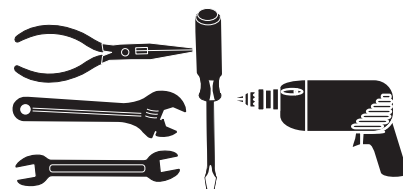

Emergencies

- **ALWAYS** know the location of the nearest **fire extinguisher**.
- **ALWAYS** know the location of the nearest **first aid kit**.



- In emergencies **always** know the location of the nearest phone or **keep a phone on the job site**. Also know the phone numbers of the nearest **ambulance, doctor** and **fire department**. This information will be invaluable in case of an emergency.

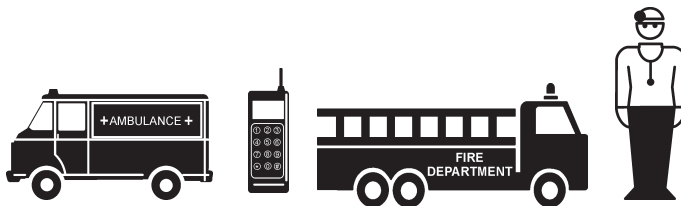

GB12BW/BS/BP LIGHTING SYSTEM — SPECIFICATIONS

Table 1. Specifications

GloBug Lighting System	
Model	GB12BW/BS/BP
Input Voltage	120 VAC
Ballast	Electronic Ballast (50Hz/60Hz)
Frequency	60 Hz Single-Phase
Max. Current	4.5 Amps
Lamp	
Lamp Type	400 Watt Metal Halide
Lumens	34,000
Light Coverage (360°)	90 ft. (27.4 meters)
Surface Temperature (Longitudinal)	476.6°F (247°C) Max.
Surface Temperature (Transversal)	417.2°F (214°C) Max.
Fan Motor	
Balloon Fan Motor	115 VAC, 60 Hz
Max. Current	.250 Amps
Pressure	0.6 inch H ₂ O .0217 PSI (0.149 kPA)
Balloon	
Diameter	33 in. (850 mm)
Material	Polyester
Heat Resisting Temperature	320 ~ 356°F (160 ~ 180°C)
Melting Temperature	500°F (260°C)
Internal Temperature of Balloon	126°F (52°C) Average
Water Resistance	1,500 mm H ₂ O
Mast (GB12BW)	
Number of Stages	2
Maximum Height (Standard)	10 feet (3 meters)
Extention Pole	13 feet (4 meters)

GB12BW/BS/BP LIGHTING SYSTEM — DIMENSIONS (GB12BW)

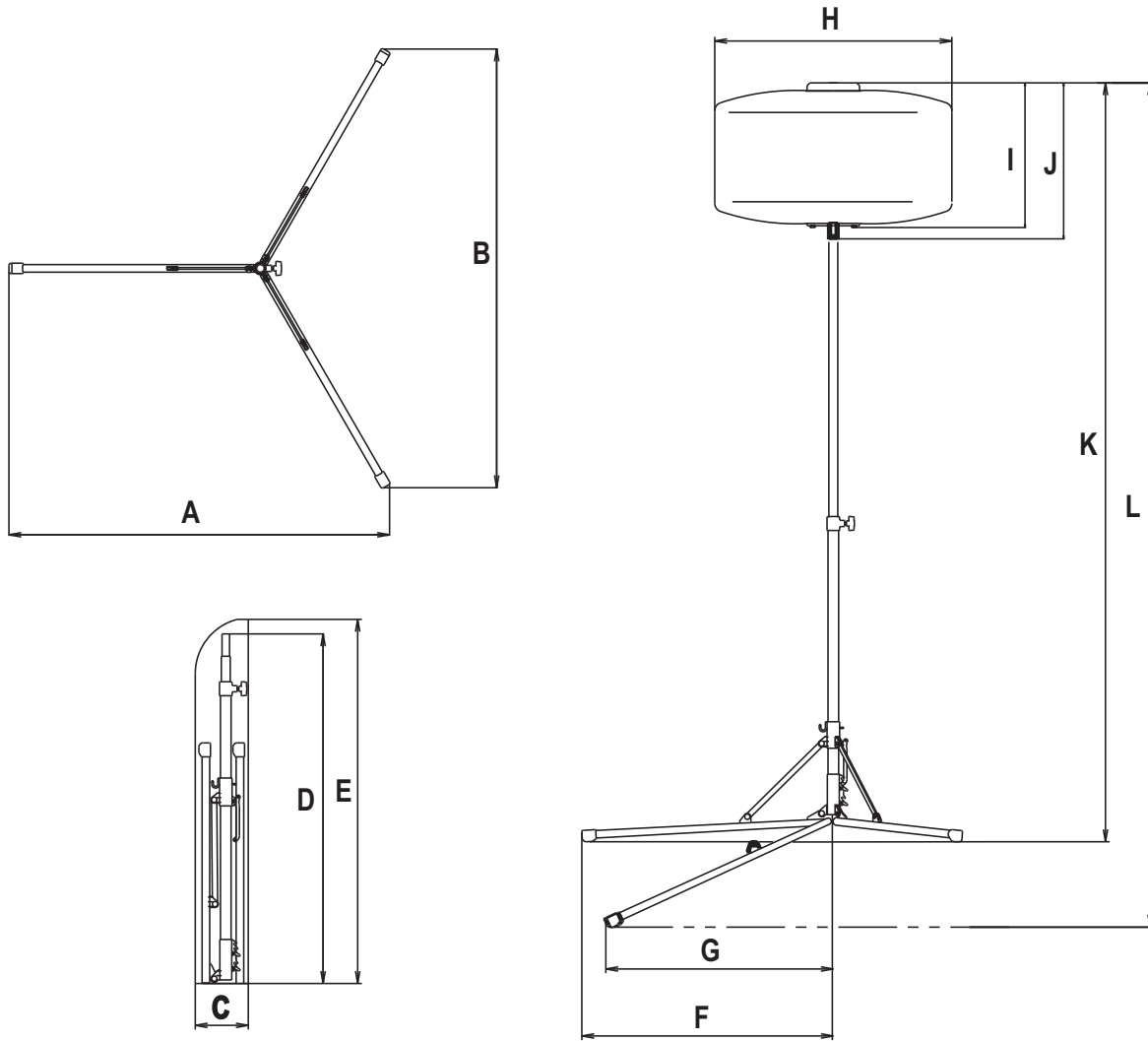

Figure 1. Dimensions (GB12BW)

TABLE 2. DIMENSIONS

Reference Letter	Dimension in. (mm.)	Reference Letter	Dimension in. (mm.)
A	52-54 in. (1,305 ~ 1,365 mm.)	G	32 in. (815 mm.)
B	60-62 in. (1,503 ~ 1,572 mm.)	H	33 in. (850 mm.)
C	8.0 in. (190 mm.)	I	20 in. (500 mm.)
D	50 in. (2,640 mm.)	J	23 in. (560 mm.)
E	52 in. (1,300 mm.)	K	73-108 in. (1,837 ~ 2,720 mm.)
F	36 in. (901 mm.)	L	85-120 in. (2,143 ~ 3,026 mm.)

GB12BW/BS/BP LIGHTING SYSTEM — DIMENSIONS (GB12BS)

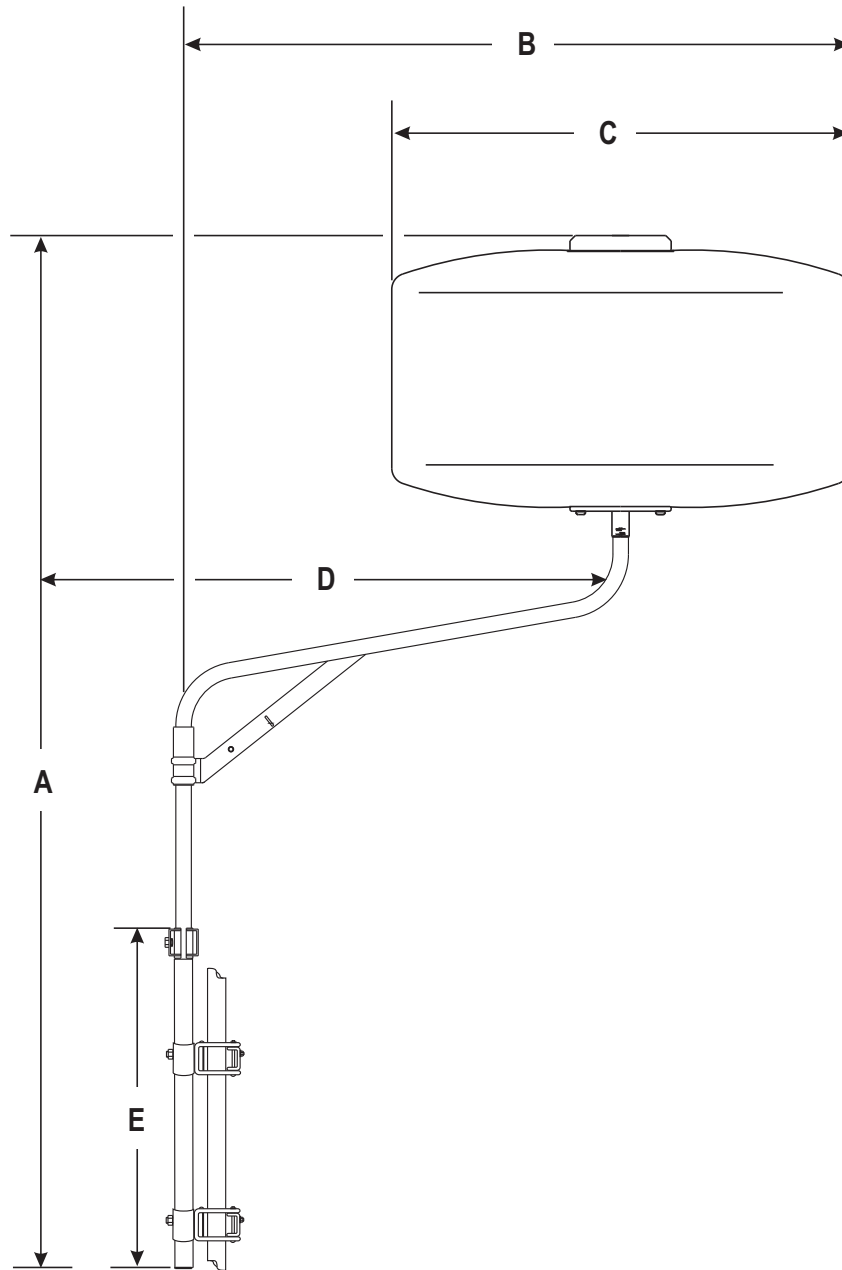

Figure 2. Dimensions (GB12BS)

TABLE 3. DIMENSIONS			
Reference Letter	Dimension in. (mm.)	Reference Letter	Dimension in. (mm.)
A	83.26 -102.95 in. (2,115 - 2,615 mm.)	D	35.00 in. (900 mm.)
B	52.16 in. (1,325 mm.)	E	35.00 in. (900 mm.)
C	33.00 in. (850 mm.)		

GB12BW/BS/BP LIGHTING SYSTEM — DIMENSIONS (GB12BP)

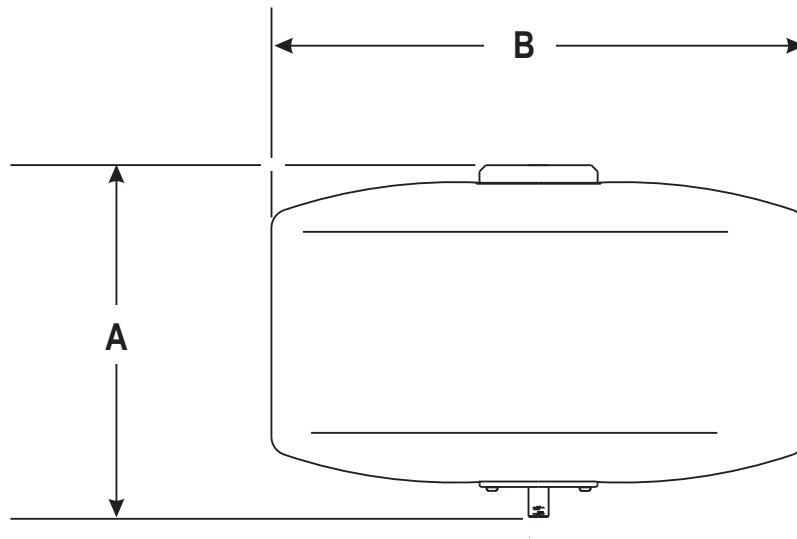
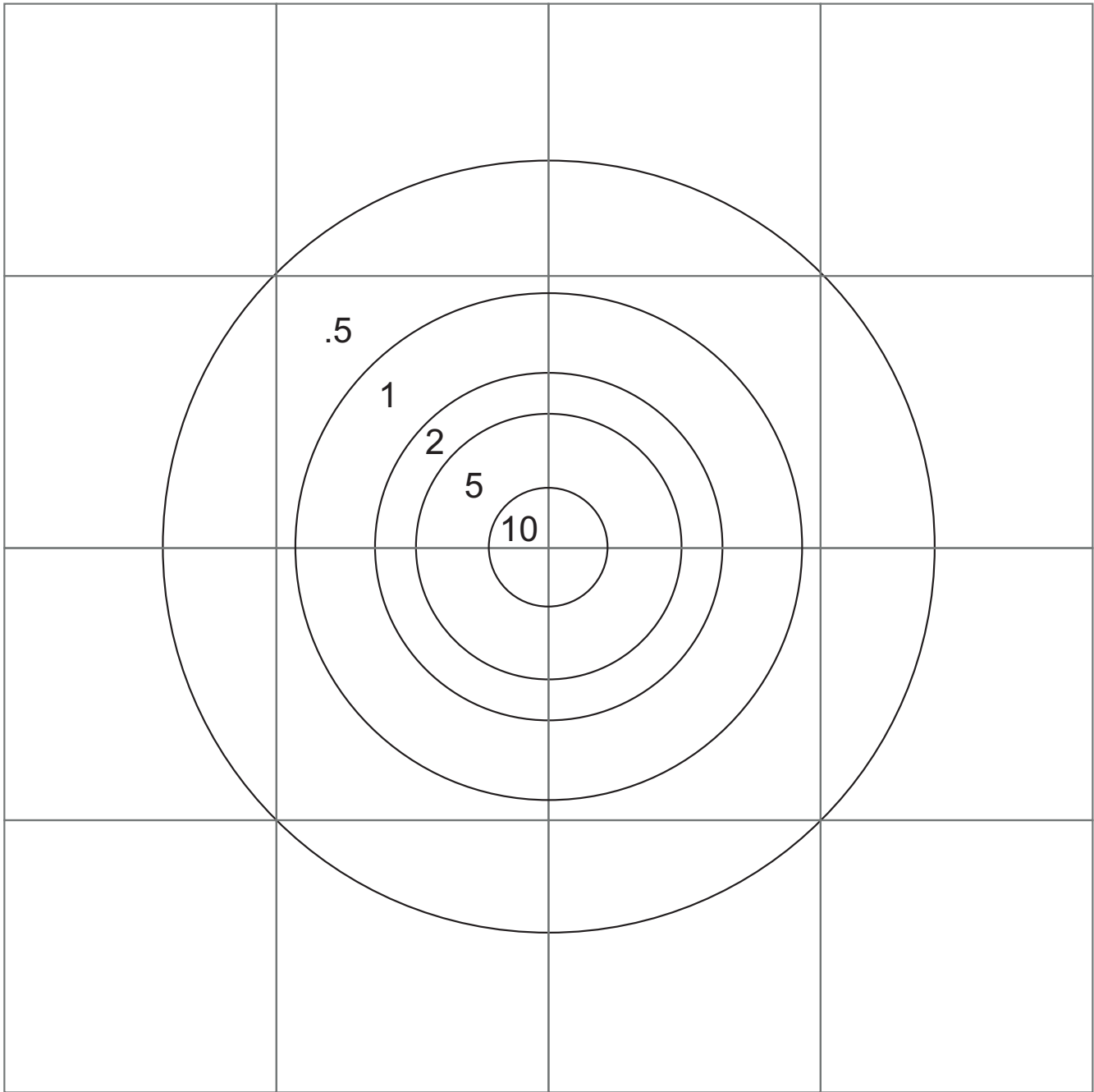

Figure 3. Dimensions (GB12BP)

TABLE 4. DIMENSIONS	
Reference Letter	Dimension in. (mm.)
A	23.00 in. (560 mm.)
B	33.00 in. (850 mm.)

GB12BW/BS/BP LIGHTING SYSTEM — FOOTCANDLE PLOT

360 degree coverage



Values listed as footcandles

Scale: Grid = 50 ft. (15.25 meters)

Figure 4. Floodlight Footcandle Plot (BAL 85-Drum Shaped)

GB12BW/BS/BP LIGHTING SYSTEM — GENERAL INFORMATION

The Multiquip GloBug GB12W, GB12BS and GB12BP are general purpose portable glare-free lighting systems. Typical applications for these types of lighting systems include construction sites, emergency road crews and backyard parties.

Balloon Envelopes

The GloBug lighting system can be configured with a variety of balloon envelopes (canopy). Please contact the MQ sales department for the balloon of your choice. The GloBug GB12BW, GB12BS and GB12BP are shipped from the factory with the drum type balloon.

Lighting

Multiquip's GloBug lighting system is comprised of one "Metal Halide" 400-watt lamp. This lamp has an output of 34,000 lumens. Typical lighting coverage is in excess 90 ft. (27 meters) in a 360 degree pattern.

Power

These GloBug lighting systems are powered by a light weight electronic ballast that is built inside the lamp housing. The input power requirements for operating the lighting system is 120 VAC, 60 Hz @ 4.5 amps.

Setup (GB12BW)

The GB12BW lighting system can be setup quickly and easily. Tripod legs can be deployed in one quick easy step and can be adjusted to two different heights. The upper position will add an additional foot to the mast height. If desired an optional 35-inch (900 mm) extension pole can be added to the mast height. Please contact the MQ sales department if you wish to add this feature to your system.

In addition the unit is equipped with an air-assist mast lowering system. This system allows the mast to be retracted slowly so that the mast will not fall rapidly when released. This feature reduces the amount of vibration or shock to the lamp.

Setup (GB12BS)

The GB12BS lighting system (offset pole) is designed to be attached to a external piece of a equipment such as a paver (Figure 5). This system is equally easy to assemble. Simply attach the supplied support clamps to an external pole or support and you are ready.

GB12BP

When only a complete lamp assembly is required please order Model GB12BP. This model number includes the lamp, protective guard, balloon protective covering and all other components that make up the lamp assembly.

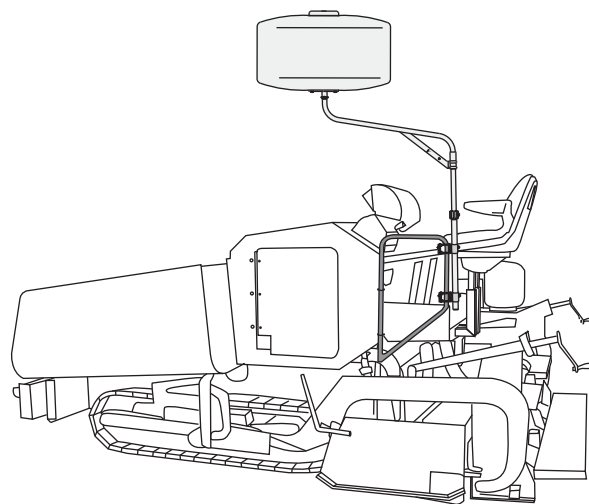

Figure 5. GB12BS Attachment (Paver)

Transport

The GB12BW lighting system can be transported (Figure 6) quite easily in two carrying cases. The first case (tripod) weighs 16 lbs. (7.25 kg) and the second case (lamp assembly) weighs 15 lbs. (6.8 kg) for a combined weight of about 31 lbs. (7.25 kg).

For ease of service or transport, the lamp assembly is equipped with a quick-disconnect connector that allows the lamp fixture to be removed quickly. This feature is extremely useful during transport of the lighting system. It is always best to remove the lamp and pack it safely so it will not be damaged.

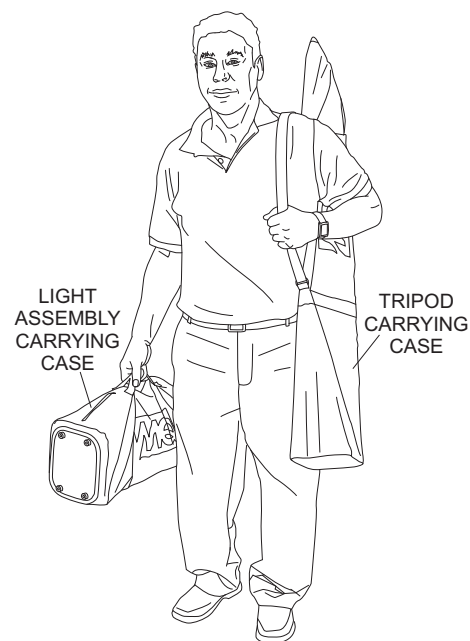

Figure 6. GB12BW Transporting

GB12BW/BS/BP LIGHTING SYSTEM — COMPONENTS

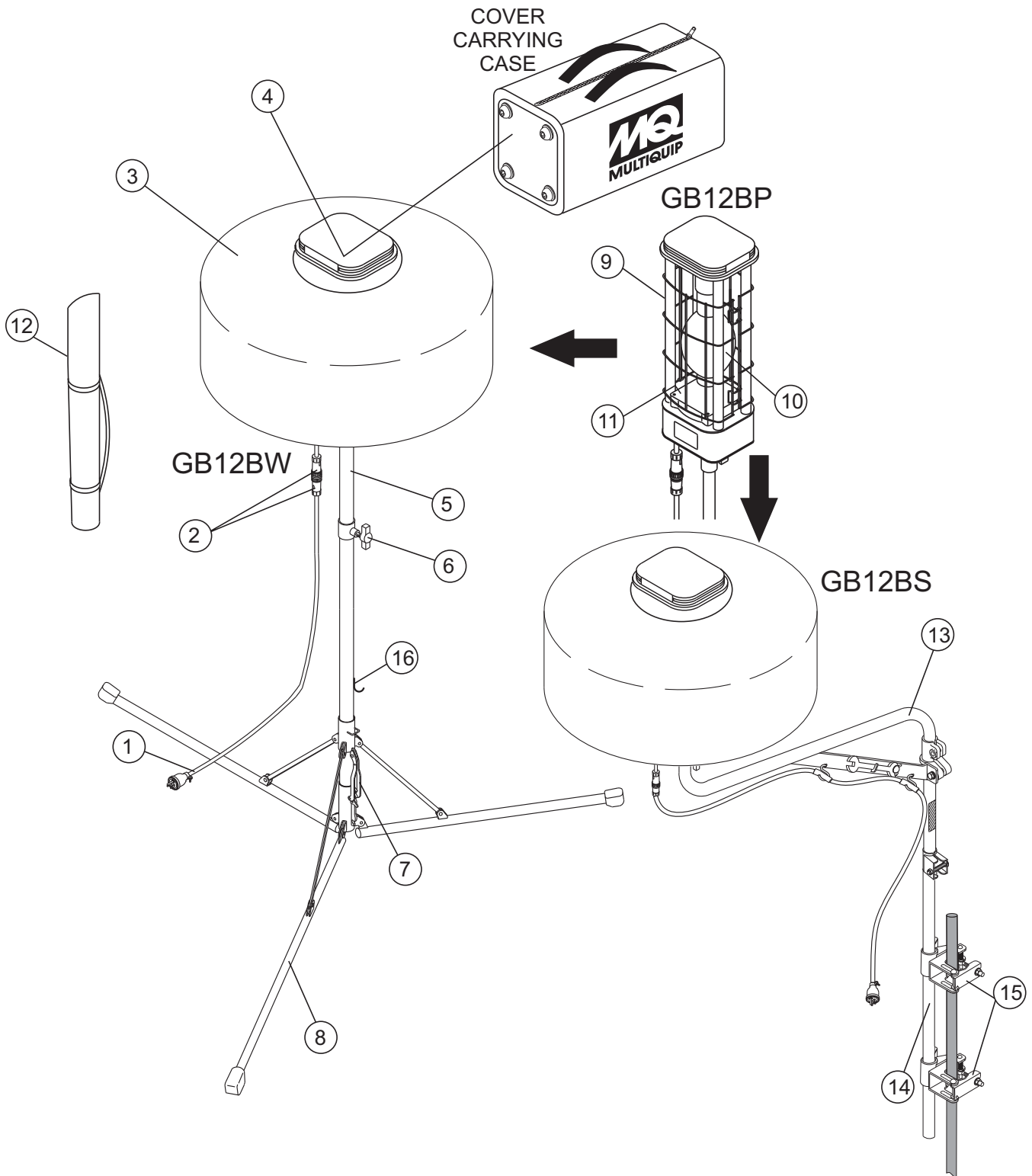

Figure 7. Major Components

GB12BW/BS/BP LIGHTING SYSTEM — COMPONENTS

Figure 7 shows the location of the components for the GloBug lighting system. The function of each component is described below:

1. **AC Power Cable** – Connect this cable to a 120 VAC, 60 Hz power source.
2. **Lamp Power Cable** – Quick-disconnect cable. Provides AC power to lamp assembly.
3. **Balloon** – This balloon is made of heat-resistant polyester, with a diameter of 33 inches (850 mm).
4. **Balloon Cover/Carrying Case** – When zipped, this protective cover acts like a carrying case. The complete lamp assembly is enclosed within the cover-carrying case. Allow a sufficient amount of time for the lamp to cool down before covering balloon. The possibility exists of the balloon getting burned.
5. **Mast** – Two stage air-assist mast. Maximum mast height is 10 ft. (3 meters) without optional extension pole. With optional extension pole, height increases to 13 ft. (4.0 meters). When raising the mast, always be on the lookout for overhead obstructions.
6. **T-Handle Bolt Lock** – Always tighten this lock to hold the lamp/balloon securely in place before raising mast.
7. **Tripod Release Latch**– Use this latch to deploy and lock tripod legs. For ease of use, the latch mechanism is attached to a velcro strap.
8. **Tripod** – Unbuckle velcro strap securing tripod legs (3), push down on any tripod leg until all tripod legs are fully deployed. To place tripod legs in the stow position, pull upward on velcro strap while pushing down on tripod pole. Pull all legs upward and secure with velcro strap.
9. **Lamp Guard** – This guard (cage) protects the lamp from being hit by objects.
10. **Lamp** – 400 watt metal-halide type lamp. Replace only with MQ recommended type lamp. Always allow a sufficient amount of time for the lamp to **cool down** before changing.
11. **Fan Motor (Blower)** – This electric motor is responsible for inflating the balloon. It will supply a pressure of .6-inch H₂O (.0217 psi /0.149 kPA). Please note that the balloon will begin to inflate as soon as power is applied to the lighting system.
12. **Tripod Carrying Case** – Use this case when transporting of the tripod is required. **ALWAYS** store tripod in this carrying case when not in use.
13. **Offset Pole** – Supports lamp assembly when attached to the main mast. Included with the offset pole is a 17/19 mm wrench.
14. **Main Pole** – Used in conjunction with the offset pole to support the lamp assembly.
15. **Pole Clamps** – Attach these clamps (2) to the main pole and external support pole. to support. Always tighten both clamps securely to prevent slippage of the light assembly.
16. **Weight Support Hook** – To add additional weight to the tripod and make the tripod more stable in windy conditions. Place a sandbag or similar weight onto this hook.

GLOBUG GB12BW/BS/BP LIGHTING SYSTEM — SETUP (GB12BW)

! CAUTION - READ MANUAL

Please read this entire manual carefully before attempting to operate any of the GloBug Lighting Systems referenced in this manual. Failure to read this manual could cause damage to the equipment and serious bodily injury to the operator.



Tripod Deployment (GB12BW)

1. Place the tripod on a ***firm level surface*** so that it will not slide or turn over. Make sure there is enough space around the unit for the tripod legs to be deployed.
2. Remove tripod from its carrying case. The tripod legs are secured by a black velcro strap (Figure 8). Squeeze both tabs on each side of buckle to unlock strap and allow tripod legs (Figure 9) to be deployed.

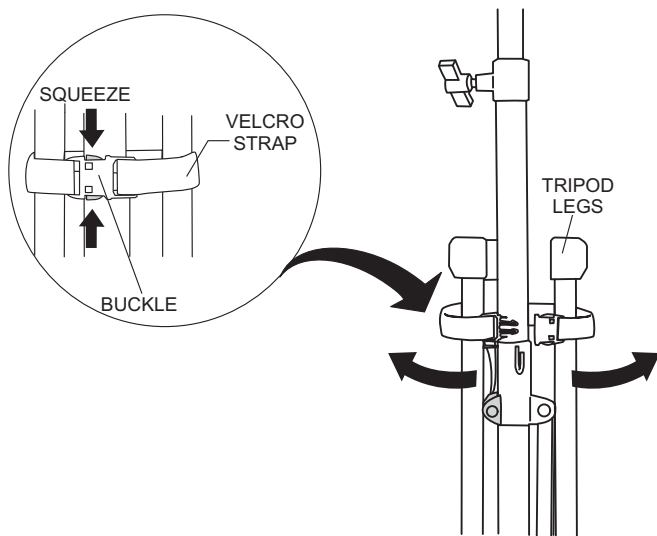

Figure 8. Velcro Strap (Open)

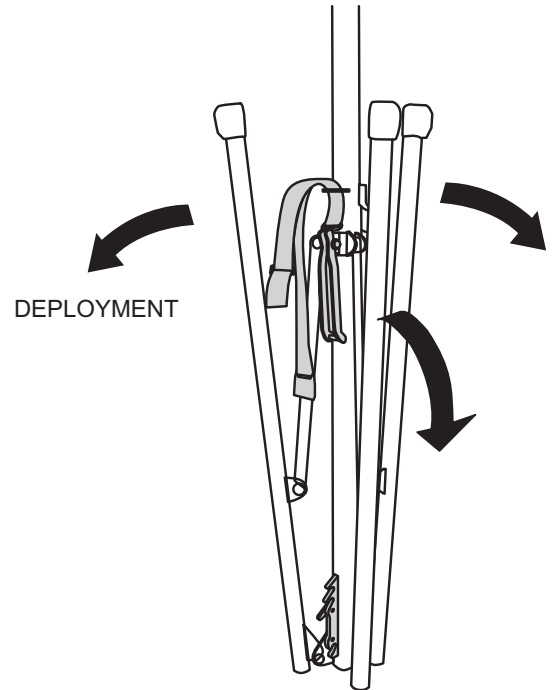

Figure 9. Tripod Deployment

3. Next, pull upward on the mast and let the tripod legs deploy. Once the tripod legs have been fully deployed make sure the legs are locked by securing the latch.

The latch (Figure 10) has two positions, upper and lower. Placing the latch in the upper position will provide 1 ft. (305 mm) more height.

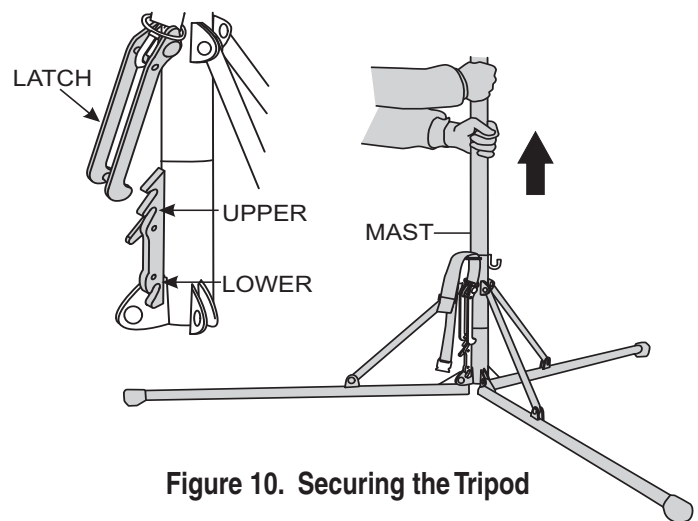

Figure 10. Securing the Tripod

GLOBUG GB12BW/BS/BP LIGHTING SYSTEM — SETUP (GB12BW)

Balloon Assembly Placement (GB12BW)

1. Place balloon assembly (Figure 11) onto mast and tighten Upper T-handle.

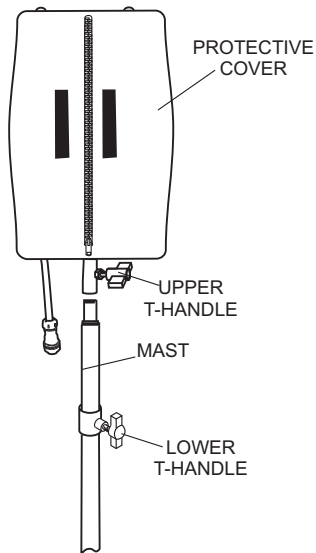

Figure 11. Light Assembly Placement

2. Expose the balloon by pulling down on the velcro tab and unzip the protective cover as shown in Figure 12. Also remove the AC power cord at this time.

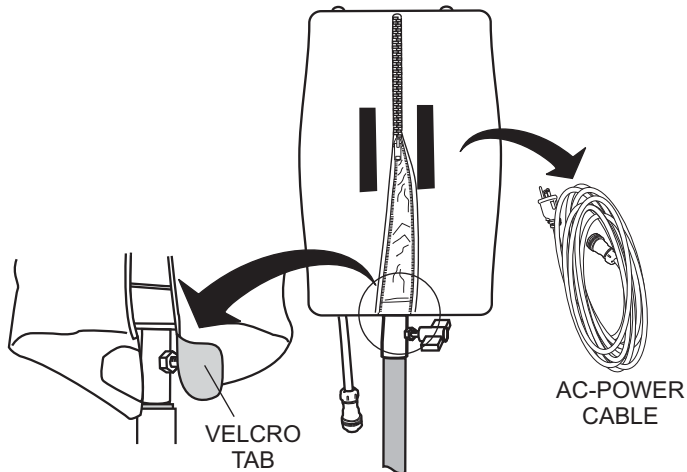

Figure 12. Removing Balloon/AC Power Cord

3. Next, fold the protective cover (Figure 13) into itself and zip.

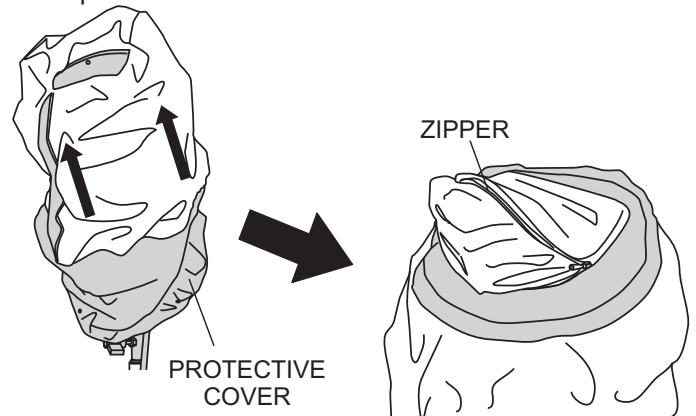

Figure 13. Folding Protective Cover

4. Connect the AC power cable (Figure 14) to the lamp power cable.

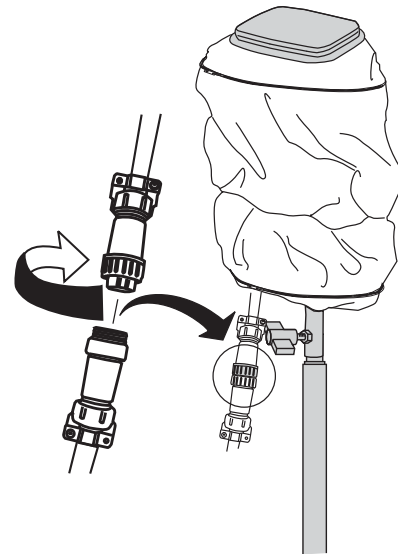

Figure 14. Connecting Power Cables

GLOBUG GB12BW/BS/BP LIGHTING SYSTEM — SETUP (GB12BW)

- Attach the S-type hook (Figure 15) on the AC power cable onto the washer-eylet located on the bottom plate of the light assembly.
- To improve stability and to prevent tipping of the light unit, place sand bags or similar type weight over the tripod legs or weight hook as shown in Figure 16.

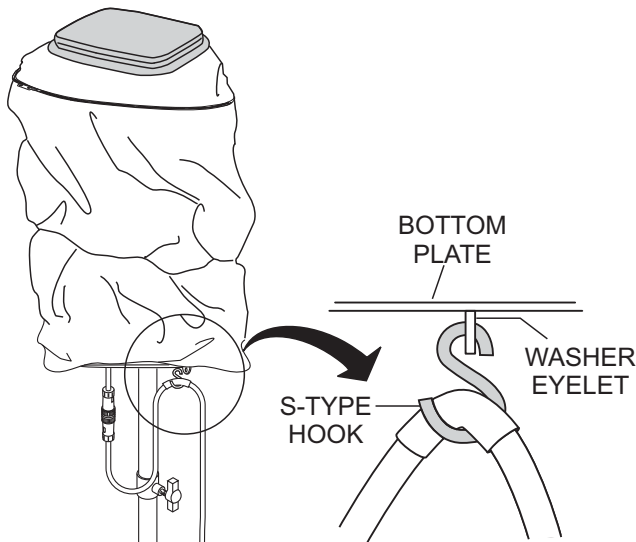

Figure 15. Securing Power Cord

Raising the Mast (GB12BW)

- Before raising the mast, make sure the upper T-handle bolt lock (Figure 16) is securely tightened. This will prevent the balloon/lamp assembly from falling off. In addition make sure that the lamp power cable is connected to the mating end of the 15 ft (4.5 meters) power source cable.

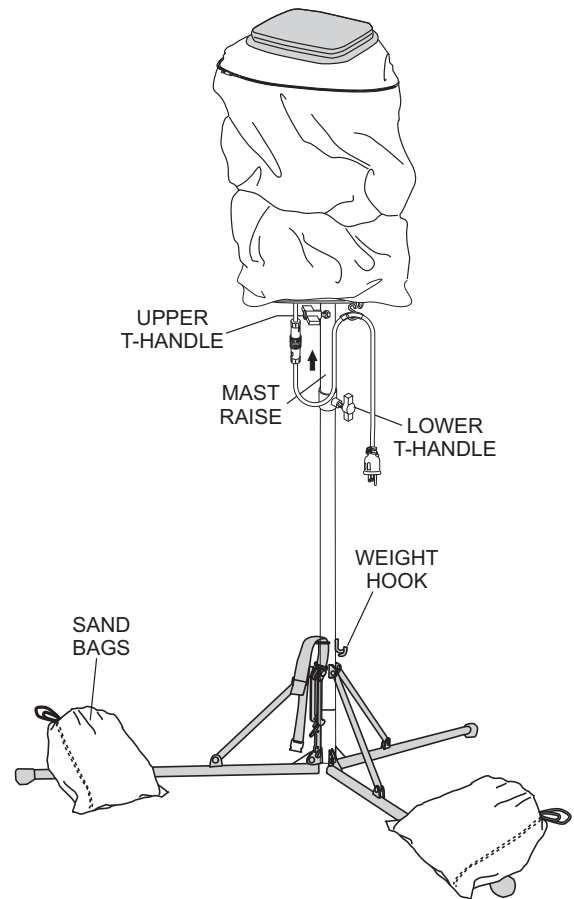
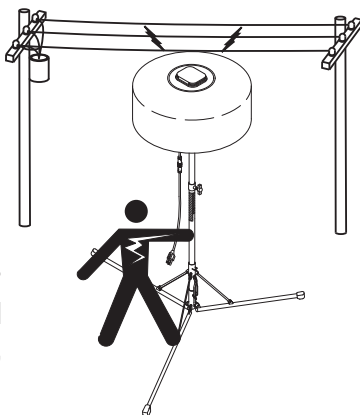

Figure 16. Sand Bags

- Raise mast to desired height and tighten lower T-handle (Figure 16) securely.

! DANGER - Overhead Obstructions

ALWAYS make sure the area above the lighting system is open and clear of overhead power lines and other obstructions. The mast extends in excess of 13 ft. (4 meters) when an optional extension is used. Contact with overhead power lines or other obstructions could result in equipment damage, **Serious Injury or Death!**



! CAUTION - MAST PINCH POINT

When raising or lowering the mast, keep hands and fingers clear of the various mast sections. This will prevent hands and fingers from getting pinched.

! DANGER - HIGH VOLTAGE POWER LINES

When raising mast, **ALWAYS** be on the lookout for overhead obstructions such as high voltage power lines. The possibility exists of electrocution, even death! if the lighting system comes in contact with **high voltage power lines.**



GLOBUG GB12BW/BS/BP LIGHTING SYSTEM — OPERATION (GB12BW)

Applying Power (GB12BW)

1. If using a portable generator, start the generator as referenced in the "Start-up Section" of the supplied generator manual.
2. Once the generator has started, plug the AC power cord from the lamp into a GFCI receptacle on the generator.
3. If using power source (Figure 17) other than a portable generator, plug the AC power cord from the lamp into a 120 VAC, 60 Hz receptacle that is protected by at least a 15 amp circuit breaker.

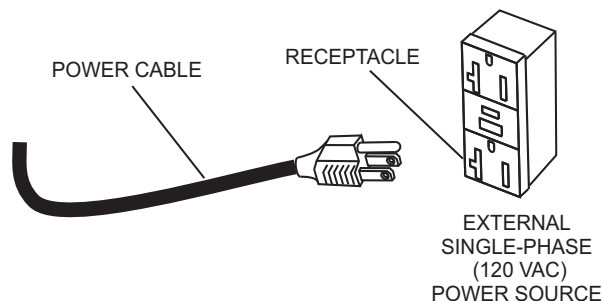

Figure 17. 120 VAC Receptacle

4. Notice that the balloon envelope will begin to deploy as soon as power is applied.
5. The lamp should now be on. If the lamp is not on, check all connections and repeat steps 1 and 2. If the lamp still does not come on, refer to the troubleshooting tables provided in the maintenance section of this manual.
6. The GB12BW lighting system is now ready for use.

Shutdown

1. If using a portable generator, shut-down the generator as referenced in the "Shutdown Section" of the supplied generator manual. **ALWAYS** place the main circuit breaker in the **OFF** position before turning off the generator.
2. If using a power source other than an AC generator, disconnect the lamp AC power cable from the power source. The balloon should begin to deflate.

3. Disconnect lamp power connector (Figure 18) from the AC power cable.

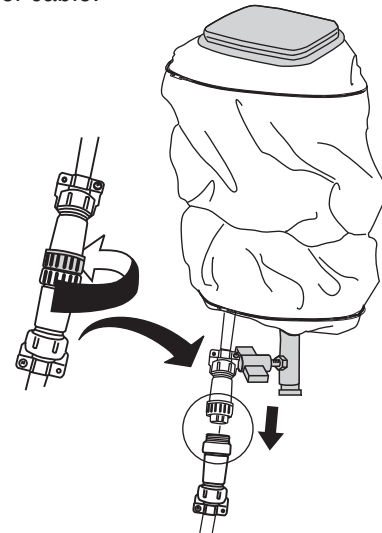

Figure 18. Disconnecting Power Cables

CAUTION - LAMP COOL DOWN

Allow a sufficient amount of time (15-20 minutes) for the lamp to **cool down**. The possibility exists of the balloon getting burned (touching the lamp).

Storage

1. Loosen the lower T-handle by turning handle counterclockwise (Figure 19). Push down on mast until mast is fully inserted into mast housing. Tighten T-handle fully.

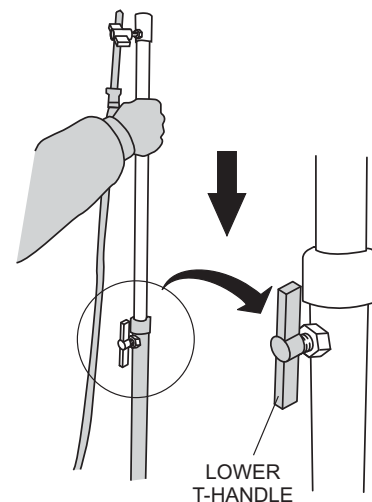

Figure 19. Lowering the Mast

2. Unzip the zipper on the protective cover (Figure 20), and pull down cover over balloon/lamp assembly.

GLOBUG GB12BW/BS/BP LIGHTING SYSTEM — STORAGE (GB12BW)

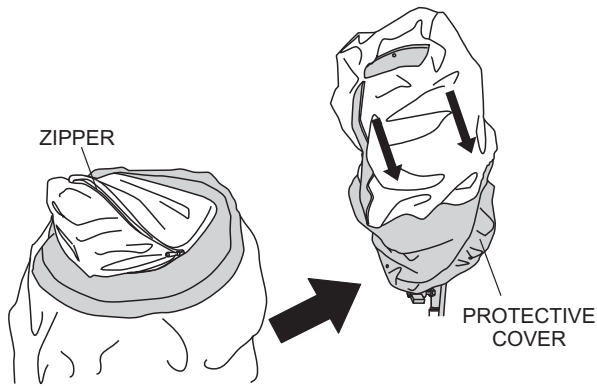

Figure 20. Unzipping the Protective Cover

- Un-hook lamp AC power cable from washer eyelet (Figure 15). Place the AC power cable inside the protective cover (Figure 21). Fully zip protective cover and fold velcro tab in place.

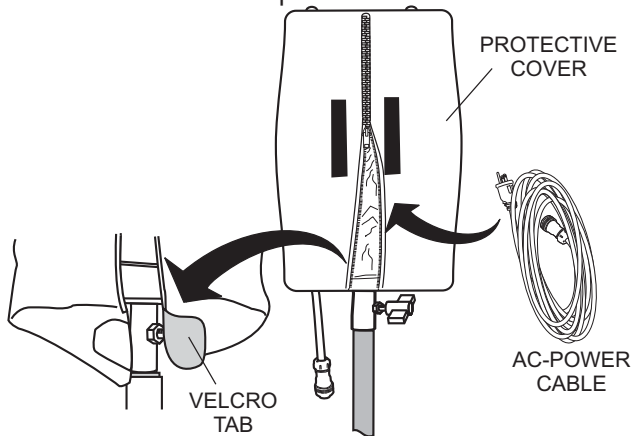

Figure 21. Unzipping the Protective Cover

- Loosen upper T-handle by turning counterclockwise and lift lamp assembly from mast.
- Store lamp assembly enclosed with its protective cover (Figure 22) in a safe location where it will not be damaged.



Figure 22. Storing Lamp Assembly

- To retract tripod legs (Figure 23) and place in the stow position, lift up on mast while pulling up on the velcro strap. Continue pulling upward on the mast until the tripod legs are fully retracted and are in the stow position.

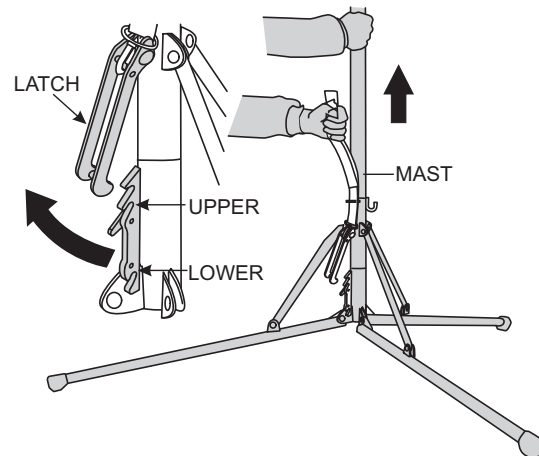

Figure 23. Retracting Tripod Legs

- Once tripod legs are in the stow position, place velcro strap (24) around all three tripod legs. Secure tripod legs by inserting the male and female connector ends of the strap into each other.

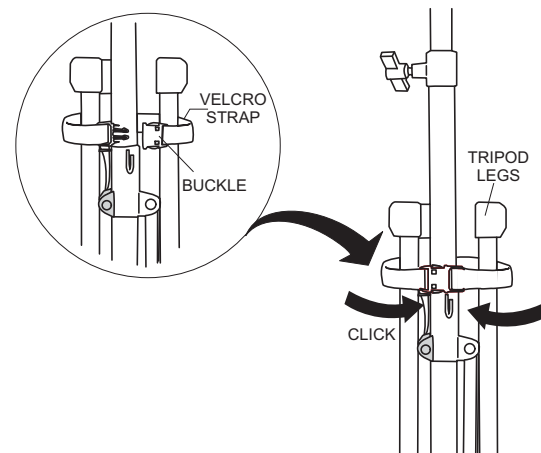

Figure 24. Velcro Strap (Closed)

- Place tripod (Figure 25) inside protective carrying case.

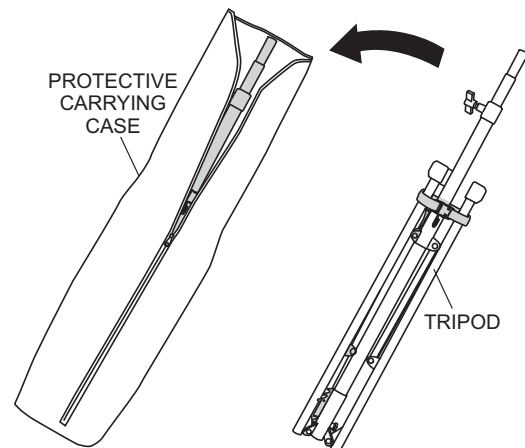
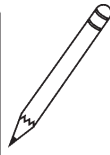
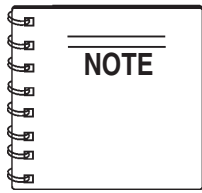

Figure 25. Velcro Strap (Closed)

GLOBUG GB12BW/BS/BP LIGHTING SYSTEM — SETUP (GB12BS)



The pole clamp assembly used in this setup procedure is a dual type clamp. One side of the clamp is for the attachment of the main pole of the lighting system. The other side of the clamp is used for the attachment of a support pole that is usually connected to a piece of equipment such as a paver.

Pole Setup (GB12BS)

Refer to Figure 26 for the following procedure.

1. Remove the offset pole (B) from the shipping container.
2. Attached to the offset pole is a 17/19 mm open-end wrench (C). Remove the wingnut (D) securing the wrench to the offset pole and remove wrench.
3. Reinsert wingnut and washer back into offset pole so they will not get lost or misplaced.
4. Remove the two pole clamp assemblies (A) from the shipping container. Attach one pole clamp assembly (E) to the main pole (F) about 3 inches (76.2 mm) down from the main pole extension clamp. Using supplied 19 mm wrench, tighten locknut on the pole clamp assembly securely.
5. Attach the other pole clamp assembly (G) to the main pole (F) about 7.0 in. (140 mm.) down from the previous attached pole clamp assembly (E). Using the 19 mm wrench, tighten locknut on the pole clamp assembly securely.
6. To attach main pole (F) to equipment support pole (I), swing open adjustable tension plate (H) on clamp so that it can accommodate the diameter of the equipment support pole. Insert equipment support pole (I) through the two equipment support pole clamp assemblies as shown in Figure 26.
7. Once the equipment support pole (I) has been seated properly, move adjustment bolt and locknut (J) into locking position. Use the supplied 17 mm wrench, to tighten locknuts (J) on both clamps securely.
8. Place offset pole (B) with adapter clamp (K) on top of adjustable extension pole (L). Make sure that offset pole has been seated correctly.

9. Using 17 mm wrench, tighten both bolts (M) on the offset adapter clamp (K) securely.
10. Place lamp assembly (N) onto offset pole (B). Tighten T-handle bolt (O) securely.

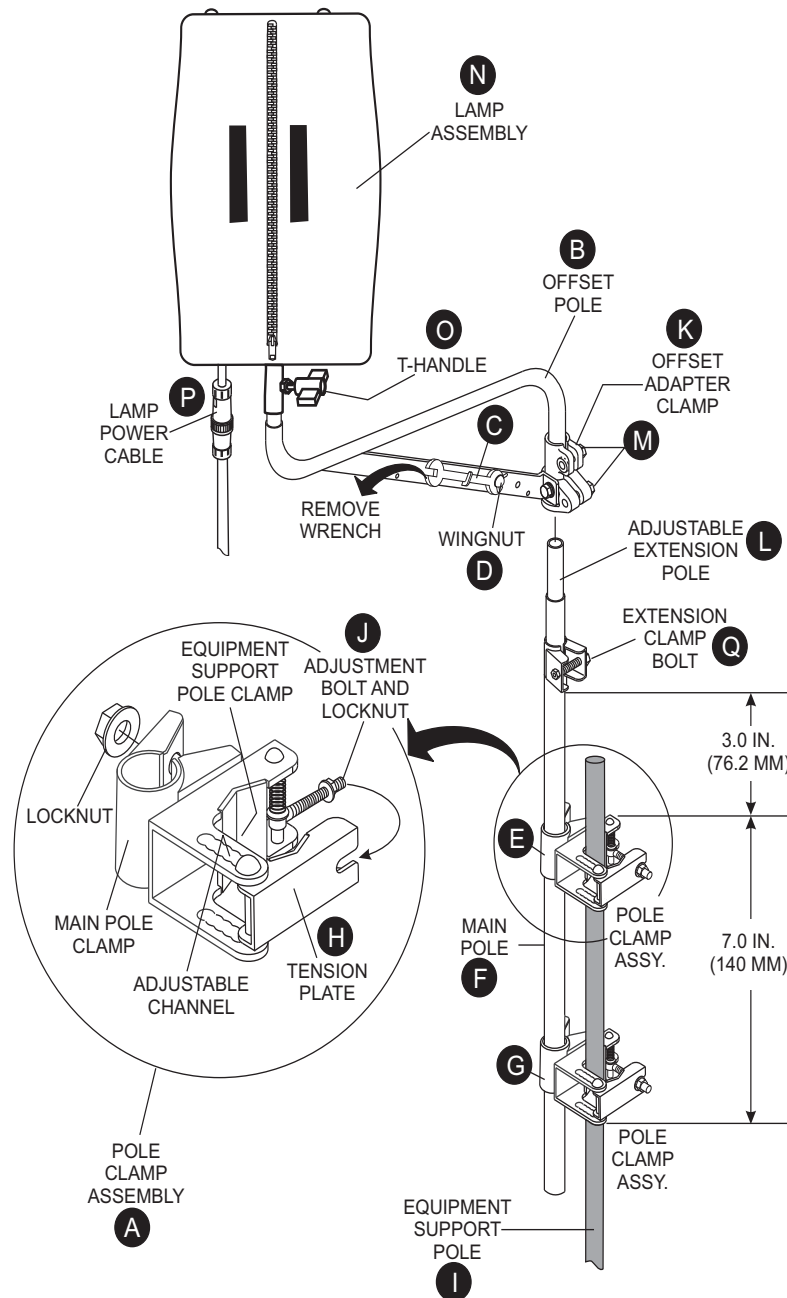

Figure 26. Offset Pole Assembly

GLOBUG GB12BW/BS/BP LIGHTING SYSTEM — SETUP (GB12BS)

Removing the Protective Covering (GB12BS)

1. Expose the balloon by pulling down on the velcro tab and unzipping the protective cover as shown in Figure 27. Also remove the AC power cord at this time.

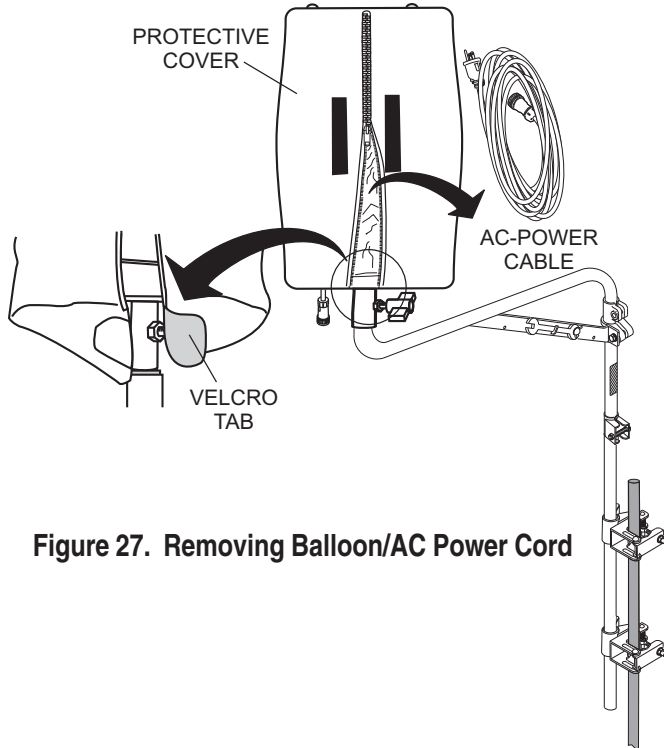

Figure 27. Removing Balloon/AC Power Cord

2. Next, fold the protective cover (Figure 28) into itself and zip.

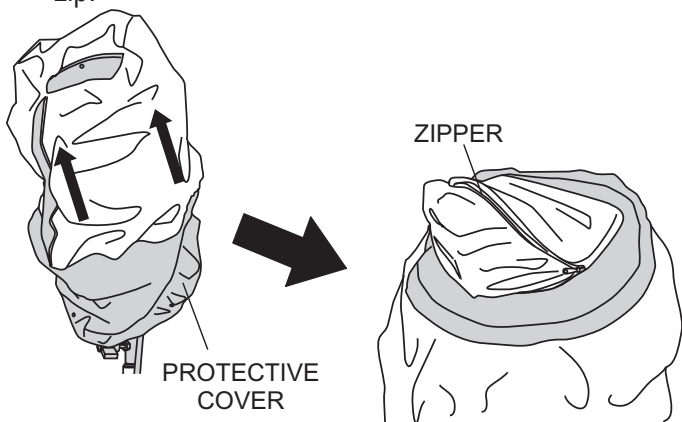

Figure 28. Folding Protective Cover

Connecting Power Cable (GB12BS)

1. Connect 15 ft. (4.6 meters) AC power cable (Figure 29) to the lamp power cable.

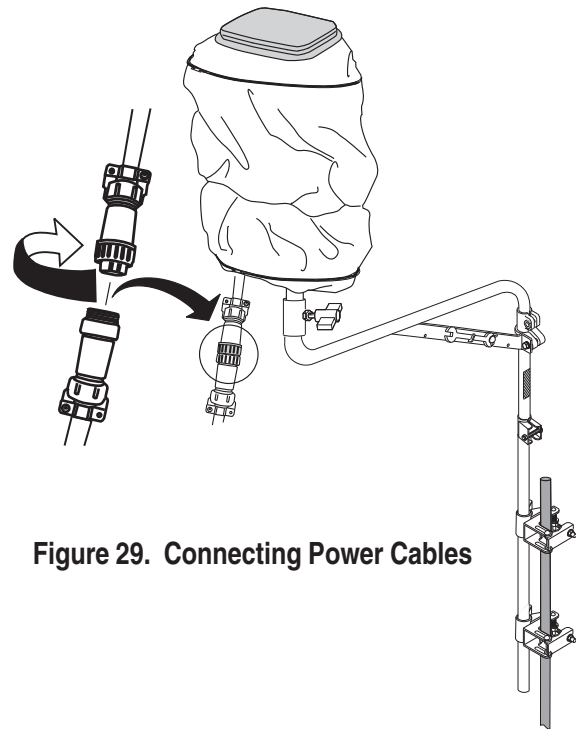

Figure 29. Connecting Power Cables

2. Attach both S-type hooks (Figure 30) on the AC power cable into the cable support holes on the offset pole.

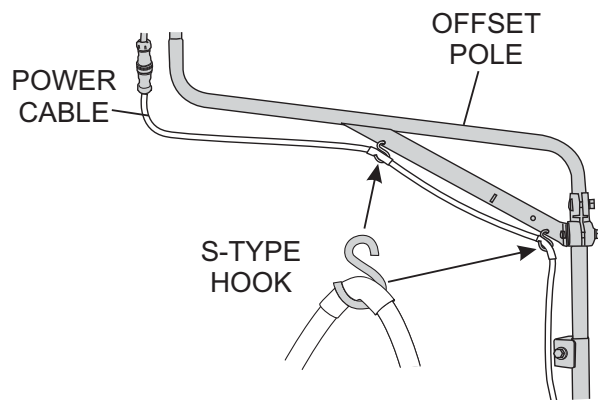

Figure 30. Attachment of S-Hooks

GLOBUG GB12BW/BS/BP LIGHTING SYSTEM — SETUP (GB12BS)

Raising the Mast (GB12BS)

1. Before raising the mast, make sure the T-handle bolt lock (see Figure 26-O) is securely tightened. This will prevent the balloon/lamp assembly from falling off. In addition make sure that the lamp power cable is connected to the mating end of the power source cable.
2. Raise extension pole (see Figure 26-L) to desired height. Watch out for any overhead obstructions.
3. Using the supplied 19 mm wrench tighten extension clamp bolt (see Figure 26-Q) securely. Place wrench in a safe place where it will not get lost.

! DANGER - Overhead Obstructions

ALWAYS make sure the area above the lighting system is open and clear of overhead power lines and other obstructions. The mast can extend in excess of 8 ft. (2.4 meters) depending on the type of equipment it is attached to. Contact with overhead power lines or other obstructions could result in equipment damage, **Serious Injury or Death!**

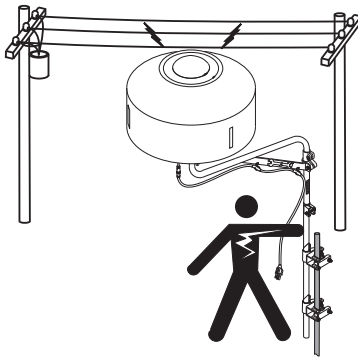

! DANGER - HIGH VOLTAGE POWER LINES

When raising mast, **ALWAYS** be on the lookout for overhead obstructions such as high voltage power lines. The possibility exists of electrocution, even death! if the lighting system comes in contact with **high voltage power lines.**



Applying Power (GB12BS)

1. If using a portable generator, start the generator as referenced in the "Start-up Section" of the supplied generator manual.
2. Once the generator has started, plug the AC power cord from the lamp into a GFCI receptacle on the generator.
3. If using a power source (Figure 31) other than a portable generator, plug the AC power cord from the lamp into a 120 VAC, 60 Hz receptacle that is protected by a at least a 15 amp circuit breaker.

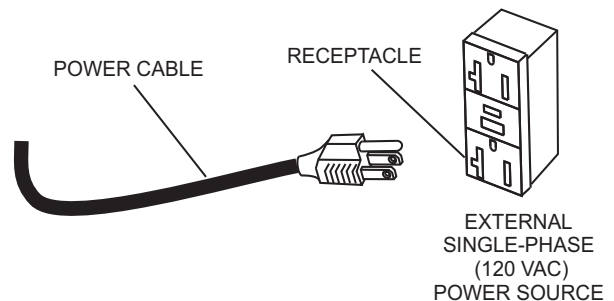

Figure 31. 120 VAC Receptacle

4. Notice that the balloon envelope will begin to deploy as soon as power is applied.
5. The lamp should now be on. If the lamp is not on, check all connections and repeat steps 1, 2 and 3. If the lamp still does not come on, refer to the troubleshooting tables provided in the maintenance section of this manual.
6. The GB12BS lighting system is now ready for use.

Shutdown

1. If using a portable generator, shut-down the generator as referenced in the "Shutdown Section" of the supplied generator manual. **ALWAYS** place the main circuit breaker in the **OFF** position before turning off the generator.
2. If using a power source other than an AC generator, disconnect the lamp AC power cable from the power source. The balloon should begin to deflate.
3. Remove and store balloon assembly as referenced in the "storage" section of the GB12BW.

GLOBUG GB12BW/BS/BP LIGHTING SYSTEM — MAINTENANCE

CAUTION - READ SAFETY GUIDELINES

Before performing any maintenance procedures, be sure to **READ** the lamp, balloon, and general safety guidelines in this manual. Failure to **read** and **understand** these safety guidelines could cause severe equipment damage and bodily harm.



Replacing the Lamp

1. Allow lamp (Figure 32) 15-20 minutes to cool before changing.

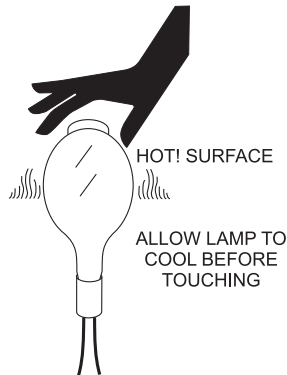

Figure 32. Hot Lamp Surface

1. If lamp assembly is attached to mast, loosen upper T-handle bolt lock that secures the lamp to the mast and remove.
2. Unzip the zipper at the bottom of the balloon. **DO NOT** use excessive force when unzipping the balloon.
3. Place lamp/balloon assembly on a suitable work bench that is free of dirt, and sharp objects that could damage the balloon.

CAUTION - BALLOON ZIPPER SAFETY

DO NOT use excessive force when zipping or unzipping the balloon. The possibility exists of the zipper tearing, which would make the balloon unusable.



4. Roll the balloon envelope (Figure 33) upwards to expose the lamp.

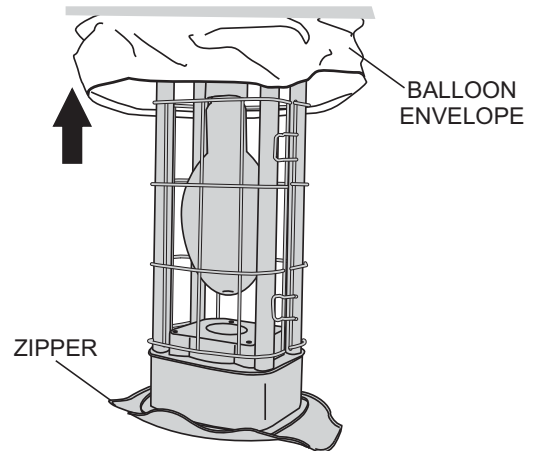

Figure 33. Rolling Up Balloon Envelope

5. Release the lamp guard locking tabs (Figure 34).

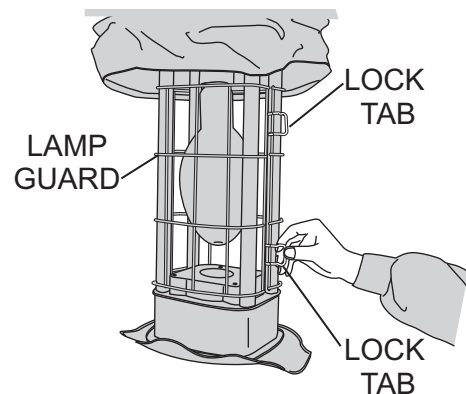

Figure 34. Releasing Lamp Guard Locking Tabs

6. Remove lamp guard (Figure 35).

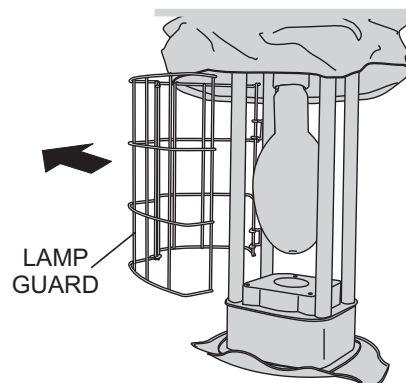

Figure 35. Lamp Guard Removal

GLOBUG SOLO Jr. LIGHTING SYSTEM — MAINTENANCE

7. Remove lamp (Figure 36) from lamp socket by turning lamp in a counterclockwise direction.

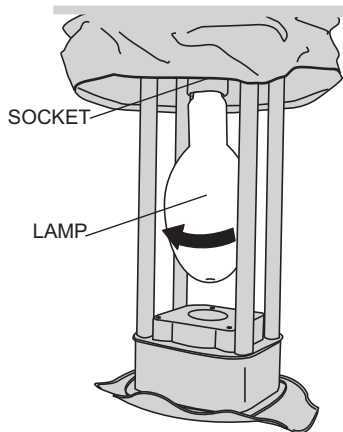

Figure 36. Removing Lamp

8. Install replacement lamp (Figure 37) into lamp socket and turn lamp in a clockwise direction until tight.

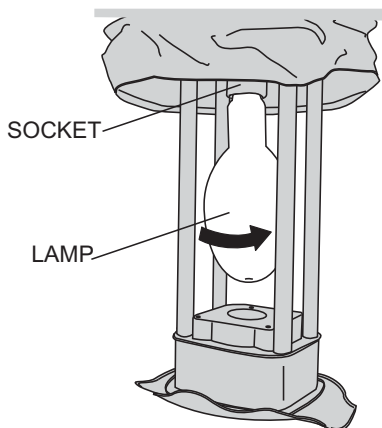

Figure 37. Installing Lamp

Replacing Balloon Envelope

1. Unzip the zipper (Figure 38) at the top and bottom of the balloon envelope (cover).

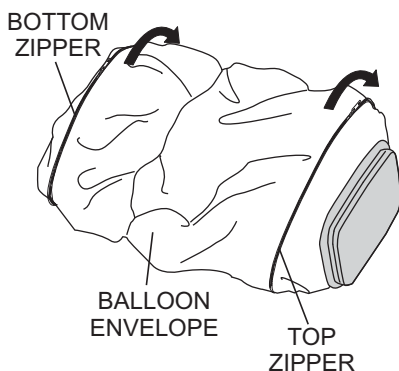

Figure 38. Unzipping the Balloon Envelope

2. Slide the old or worn balloon envelope (Figure 39) over the top of the lamp guard assembly.

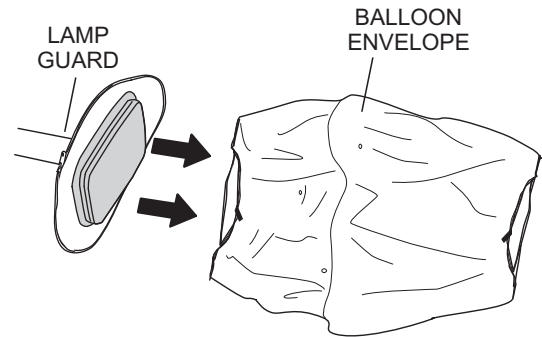

Figure 39. Removing the Balloon Envelope

3. Slide the new balloon (Figure 40) envelope over the top of the lamp guard assembly.

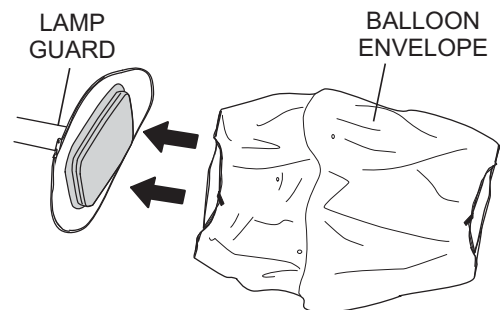

Figure 40. Installing New Balloon Envelope

4. Zip up the zipper (Figure 41) at the top and bottom of the balloon envelope (cover).

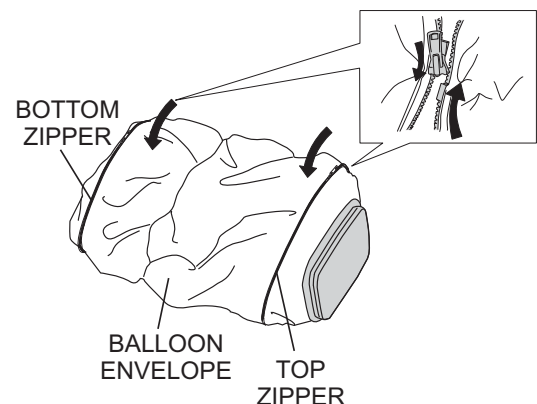

Figure 41. Zipping the Balloon Envelope

GB12BW/BS/BP LIGHTING SYSTEM — MAINTENANCE

Filter Replacement

! WARNING - HOT SURFACE (LAMP FRAME)

DO NOT replace filter immediately, allow a sufficient amount of time for the lamp assembly to cool down before changing filter.



1. Remove the balloon as described in the "Removing the Lamp/Balloon" section.
2. Disconnect the lamp power cable.
3. Rotate the balloon/lamp base assembly so that the filter is facing upwards. See Figure 42.

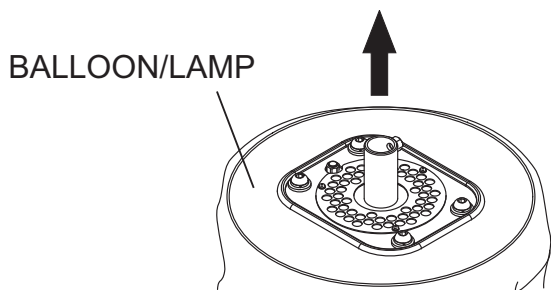

Figure 42. Balloon/Lamp Placement

4. Using a small phillips-head screwdriver, remove the three screws/washers that secure the air plate to the lamp base (Figure 43). Remove air plate and filter.

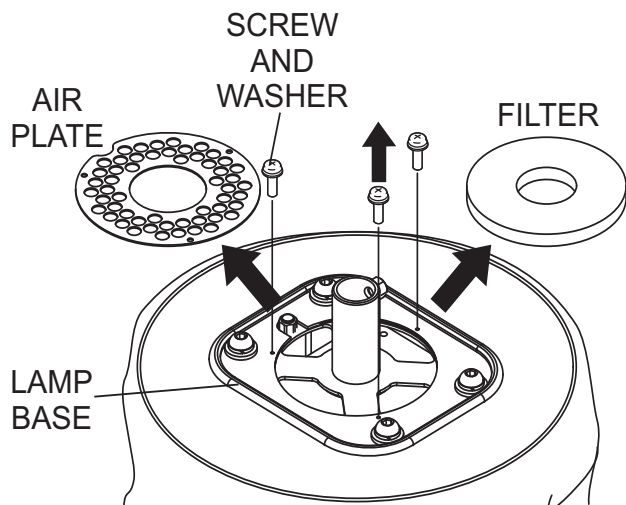

Figure 43. Filter Removal

5. Install a new filter over the brace as shown in Figure 44. Be sure to align the **cut of the filter** over the brace.

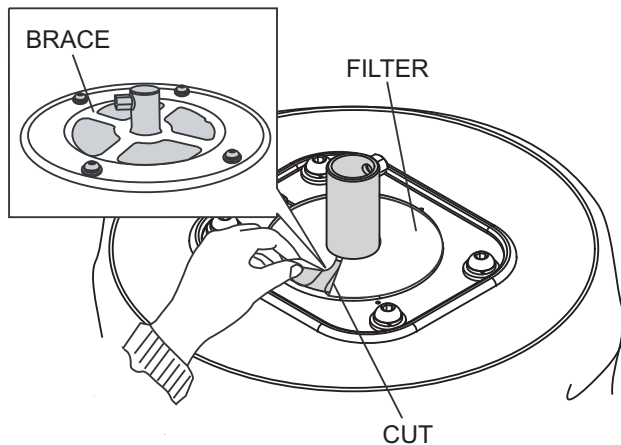

Figure 44. Filter Placement

! CAUTION - FILTER ALIGNMENT

When placing the filter element, always align the cut of the filter on top of the brace. This will keep the filter from being dislodged and getting damaged.

6. Using a small phillips-head screwdriver, reinstall the three screws/washers to secure the air plate to the lamp base (Figure 45).

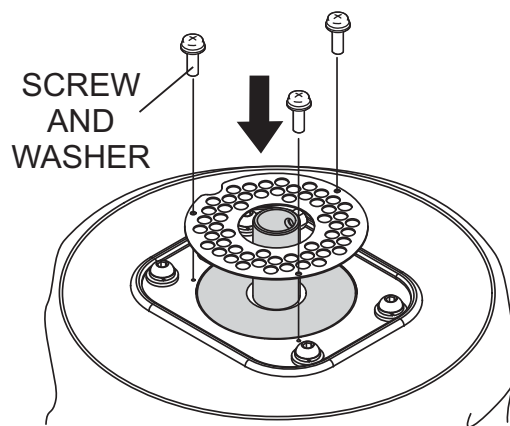

Figure 45. Filter/Plate Install

GB12BW/BS/BP LIGHTING SYSTEM — MAINTENANCE (WIRING DIAGRAM)

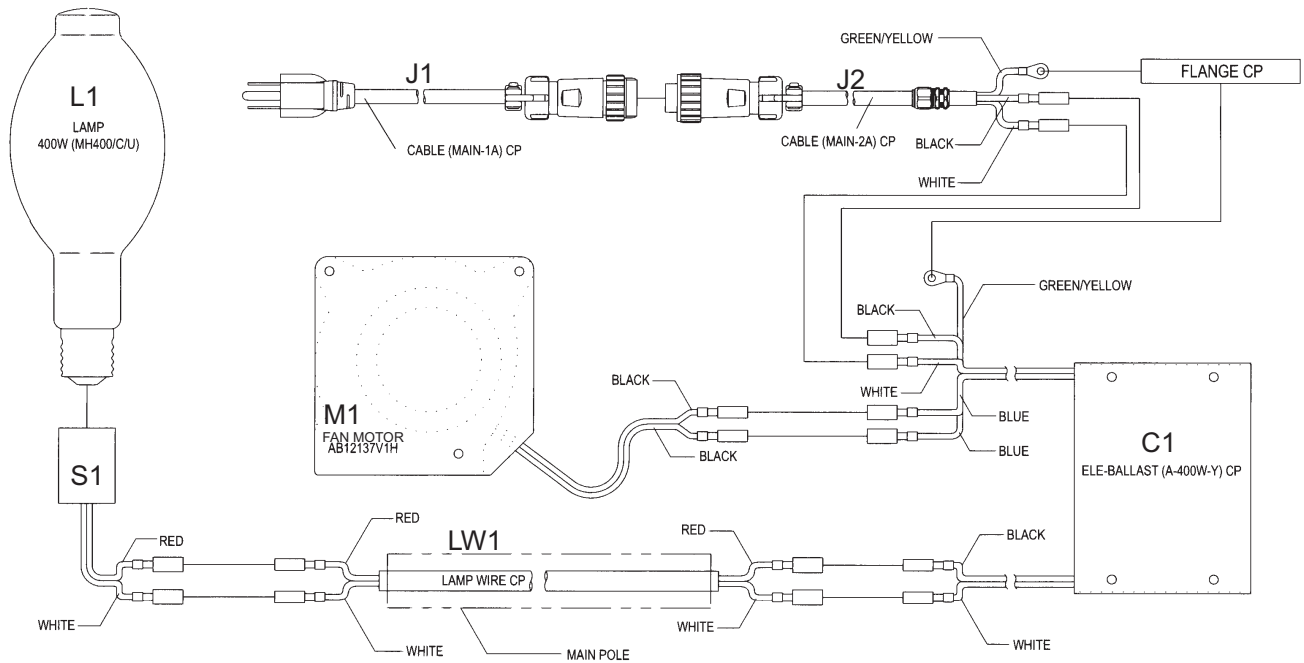

Figure 46. Electrical Wiring Diagram

TABLE 5. REFERENCE DESIGNATIONS

REF. DESC.	DESCRIPTION	PART NUMBER
J1	CABLE (MAIN-1A) CP	A300135500
J2	CABLE (MAIN-2A) CP	A300135600
C1	ELE-BALLAST (A-400W-Y)CP	A300135300
Lw1	Lamp WIRE CP	A300075200
S1	SOCKET ASSY.	E000009601
L1	400W (MH400/C/U)	E000031700

GB12BW/BS/BP LIGHTING SYSTEM — MAINTENANCE

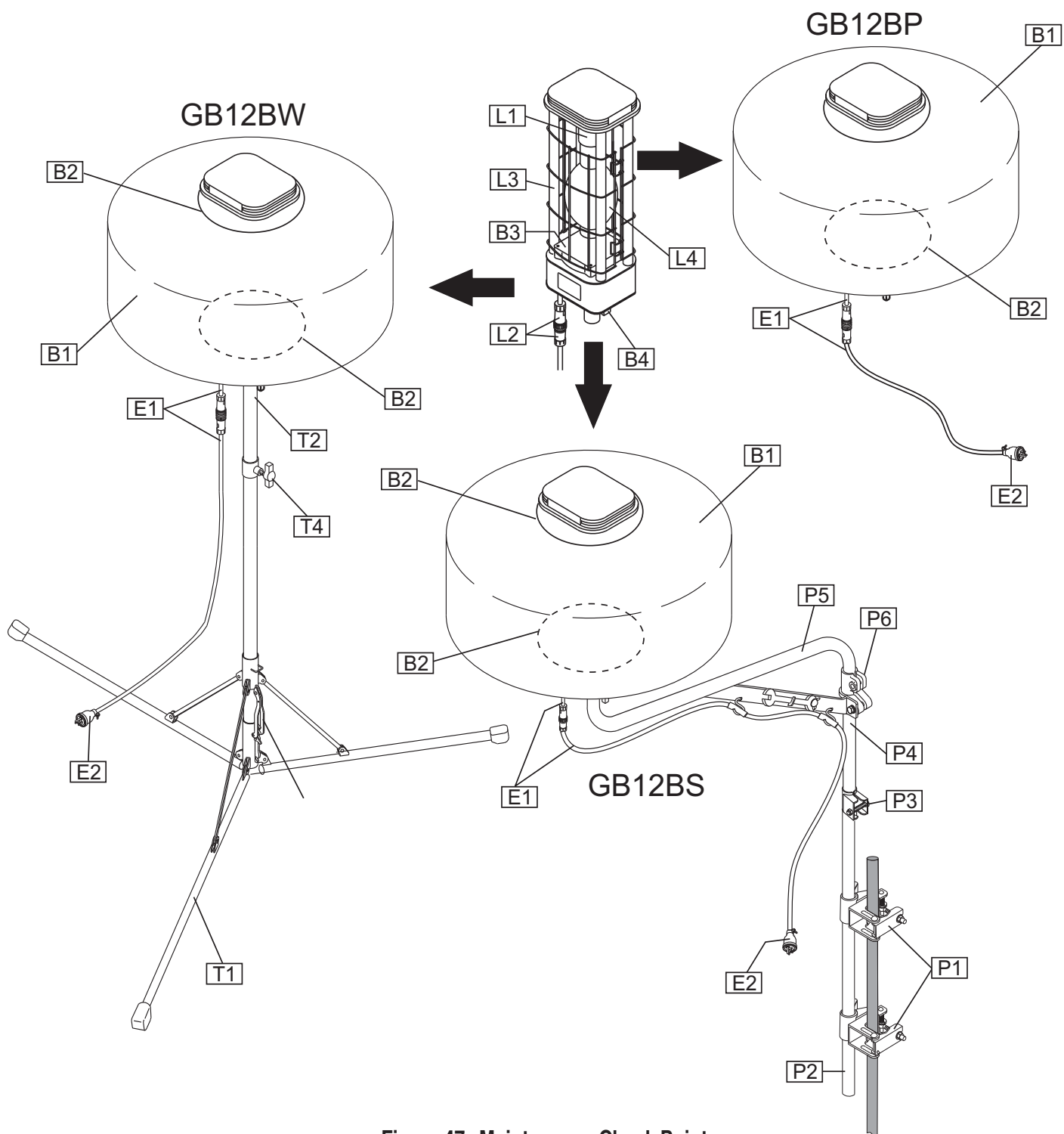

Figure 47. Maintenance Check Points

GB12BW/BS/BP LIGHTING SYSTEM — MAINTENANCE

For a prolonged life cycle an extended quality follow the recommended GloBug lighting system service guidelines as referenced in Figure 47 and Table 6.

TABLE 6. PERIODIC CHECK AND MAINTENANCE

FIGURE	PART	CHECK ITEM	SOLUTION		
Lamp	L1	Lamp (Base)	Lamp base loose?	Screw in securely	❖
	L2	Connector	Cable disconnected or loose?	Connect securely	❖
	L3	Pipe Frame	Frame pipe skewed?	Replace	❖
	L4	Lamp	Defective lamp?	Replace	■
Balloon	B1	Balloon (Envelope)	Defective or dirty?	Replace	❖
	B2	Zipper	Broken?	Replac.	❖
	B3	Fan Motor (Blower)	Not working properly?	Repair or replace	❖
	B4	T-Handle bolt (Balloon)	Broken?	Replace	❖
Electric	E1	Power Cable	Defective or worn cable?	Replace.	❖
	E2	Plug	Damaged?	Replace.	❖
Tripod	T1	Tripod	Damaged or not working properly?	Replace	■
	T2	Mast	Damaged or not working properly?	Replace	❖
	T3	Latch	Damaged?	Replace	❖
	T4	T-Handle bolt (Mast)	Damaged?	Replace	❖
Pole	P1	Clamp	Broken?	Repalce	❖
	P2	Support pipe	Support pipe bent or damaged?	Replace	❖
	P3	Support bolt	Support bolt loose?	Tighren securely	❖
	P4	Straight pole	Straight pole bent or damaged?	Repalce	❖
	P5	Offset pole	Offset pole bent or damaged?	Replace	❖
	P6	Offselt bolt	Offset bolt loose?	Tighten securely	❖

❖ - Daily Check ■ - Every 20 Hours ● - Every 100 hours ▲ - Every 500 hours

GB12BW/BS/BP LIGHTING SYSTEM — TROUBLESHOOTING (LAMPS)

Practically all breakdowns can be prevented by proper handling and maintenance inspections, but in the event of a breakdown, please take a remedial action following the diagnosis based on the Lamp Troubleshooting (Table 7) information shown below.

If the problem cannot be remedied, please leave the unit just as it is and consult or company's service department.

TABLE 7. LAMP TROUBLESHOOTING

SYMPTOM	POSSIBLE PROBLEM	SOLUTION
Lamp does not light.	Is plug disconnected?	Plug in correctly.
	Is lamp power switched off?	Turn on switch.
	Is lamp loose?	Screw lamp securely into socket.
	Is power connector disconnected or loose?	Connect disconnected connector.
	Are any other electric appliances (other than light tower) plugged into power source?	Unplug all other appliances.
	Is model of lamp incompatible?	Use genuine MQ lamp.
	Is lamp not cool enough to light again? (Interval of 20 to 30 minutes is required before turning on lamp again)	Wait for lamp to cool down.
Lamp only lights for a short time.	Is ambient temperature too high (more than 104 °F (40 °C))?	Move lamp where there is proper ventilation.
Balloon does not inflate.	Is fan motor (blower) not working properly?	Check or repair fan motor (blower).
	Is balloon envelope defective?	Repair or replace balloon envelope.

GB12BW/BS/BP LIGHTING SYSTEM — TROUBLESHOOTING (MAST)

Practically all breakdowns can be prevented by proper handling and maintenance inspections, but in the event of a breakdown, please take a remedial action following the diagnosis based on the Mast Troubleshooting (Table 8) information shown below.

If the problem cannot be remedied, please leave the unit just as it is and consult or company's service department.

TABLE 8. MAST TROUBLESHOOTING

SYMPTOM	POSSIBLE PROBLEM	SOLUTION
Mast cannot be raised.	Is Mast Lock Lever locked?	Release Mast Lock Lever.
The mast cannot be lowered.	Is Mast Lock Lever locked?	Release Mast Lock Lever.

EXPLANATION OF CODE IN REMARKS COLUMN

The following section explains the different symbols and remarks used in the Parts section of this manual. Use the help numbers found on the back page of the manual if there are any questions.

The contents and part numbers listed in the parts section are subject to change **without notice**. Multiquip does not guarantee the availability of the parts listed.

Sample Parts List:

NO.	PART NO.	PART NAME	QTY.	REMARKS
1	12345	BOLT	1	INCLUDES ITEMS W/*
2*		WASHER, 1/4 IN.		NOT SOLD SEPARATELY
2*	12347	WASHER, 3/8 IN.	1	MQ-45T ONLY
3	12348	HOSE	A/R	MAKE LOCALLY
4	12349	BEARING	1	S/N 2345B AND ABOVE

NO. Column

Unique Symbols - All items with same unique symbol (*, #, +, %, or >) in the number column belong to the same assembly or kit, which is indicated by a note in the "Remarks" column.

Duplicate Item Numbers - Duplicate numbers indicate multiple part numbers are in effect for the same general item, such as different size saw blade guards in use or a part that has been updated on newer versions of the same machine.

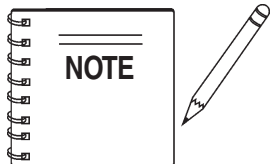

When ordering a part that has more than one item number listed, check the remarks column for help in determining the proper part to order.

PART NO. Column

Numbers Used - Part numbers can be indicated by a number, a blank entry, or TBD.

TBD (To Be Determined) is generally used to show a part that has not been assigned a formal part number at time of publication.

A blank entry generally indicates that the item is not sold separately or is not sold by Multiquip. Other entries will be clarified in the "Remarks" Column.

QTY. Column

Numbers Used - Item quantity can be indicated by a number, a blank entry, or A/R.

A/R (As Required) is generally used for hoses or other parts that are sold in bulk and cut to length.

A blank entry generally indicates that the item is not sold separately. Other entries will be clarified in the "Remarks" Column.

REMARKS Column

Some of the most common notes found in the "Remarks" Column are listed below. Other additional notes needed to describe the item can also be shown.

Assembly/Kit - All items on the parts list with the same unique symbol will be included when this item is purchased.

Indicated by:
"INCLUDES ITEMS W/(unique symbol)"

Serial Number Break - Used to list an effective serial number range where a particular part is used.

Indicated by:
"S/N XXXXX AND BELOW"
"S/N XXXX AND ABOVE"
"S/N XXXX TO S/N XXX"

Specific Model Number Use - Indicates that the part is used only with the specific model number or model number variant listed. It can also be used to show a part is NOT used on a specific model or model number variant.

Indicated by:
"XXXXX ONLY"
"NOT USED ON XXXX"

"Make/Obtain Locally" - Indicates that the part can be purchased at any hardware shop or made out of available items. Examples include battery cables, shims, and certain washers and nuts.

"Not Sold Separately" - Indicates that an item cannot be purchased as a separate item and is either part of an assembly/kit that can be purchased, or is not available for sale through Multiquip.

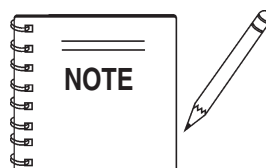

Specification and part number are subject to change without notice.

GB12BW/BS/BP LIGHTING SYSTEM — SPARE PARTS

GloBug LIGHTING SYSTEM **1 TO 3 UNITS**

<u>Qty.</u>	<u>P/N</u>	<u>Description</u>
2	E000031700	BULB
2	A300135300	ELECTRICAL BALLAST
2	A100015901	BALLOON CLOTH

GB12BW/BS/BP LIGHTING SYSTEM — NAMEPLATE AND DECALS

NAMEPLATE AND DECALS.

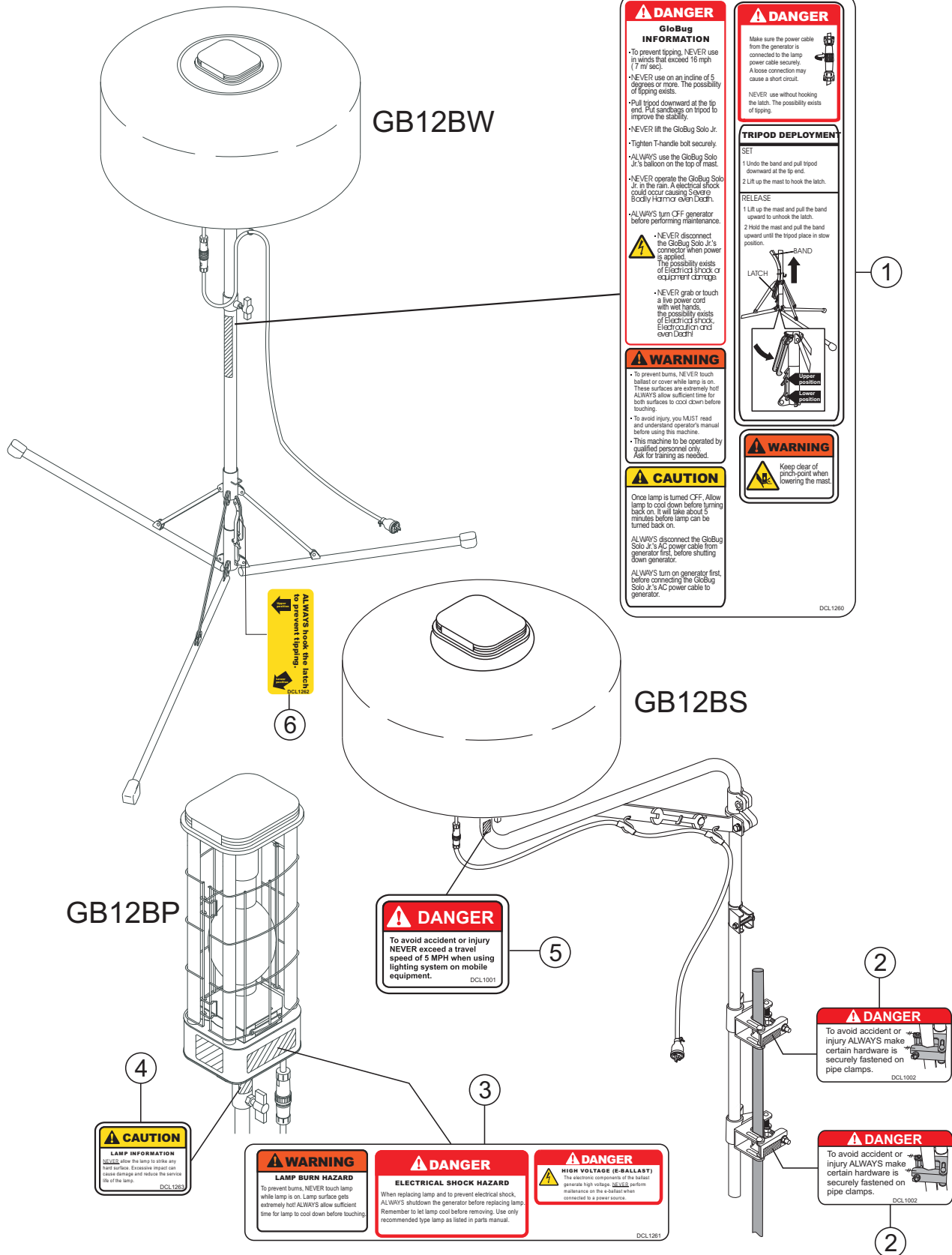

GB12BW/BS/BP LIGHTING SYSTEM— NAMEPLATE AND DECALS

NAMEPLATE AND DECALS.

<u>NO.</u>	<u>PART NO.</u>	<u>PART NAME</u>	<u>QTY.</u>	<u>REMARKS</u>
1	DCL1260	DECAL; DANGER, CAUTION, WARNING INFO.	1	
2	DCL1002	DECAL; DANGER, PIPE CLAMP	1	
3	DCL1261	DECAL; DANGER, ELECTRICAL SHOCK HAZ. WARNING, BURN HAZARD (LAMP) DANGER, HIGH VOLTAGE	1	
4	DCL1263	DECAL; CAUTION, LAMP INFORMATION	1	
5	DCL1001	DECAL; DANGER, TRAVEL SPEED	1	
6	DCL1262	DECAL; LATCH	1	

GB12BW/BS/BP LIGHTING SYSTEM — MAST/TRIPOD ASSY. (GB12BW)

MAST/TRIPOD ASSY. (GB12BW)

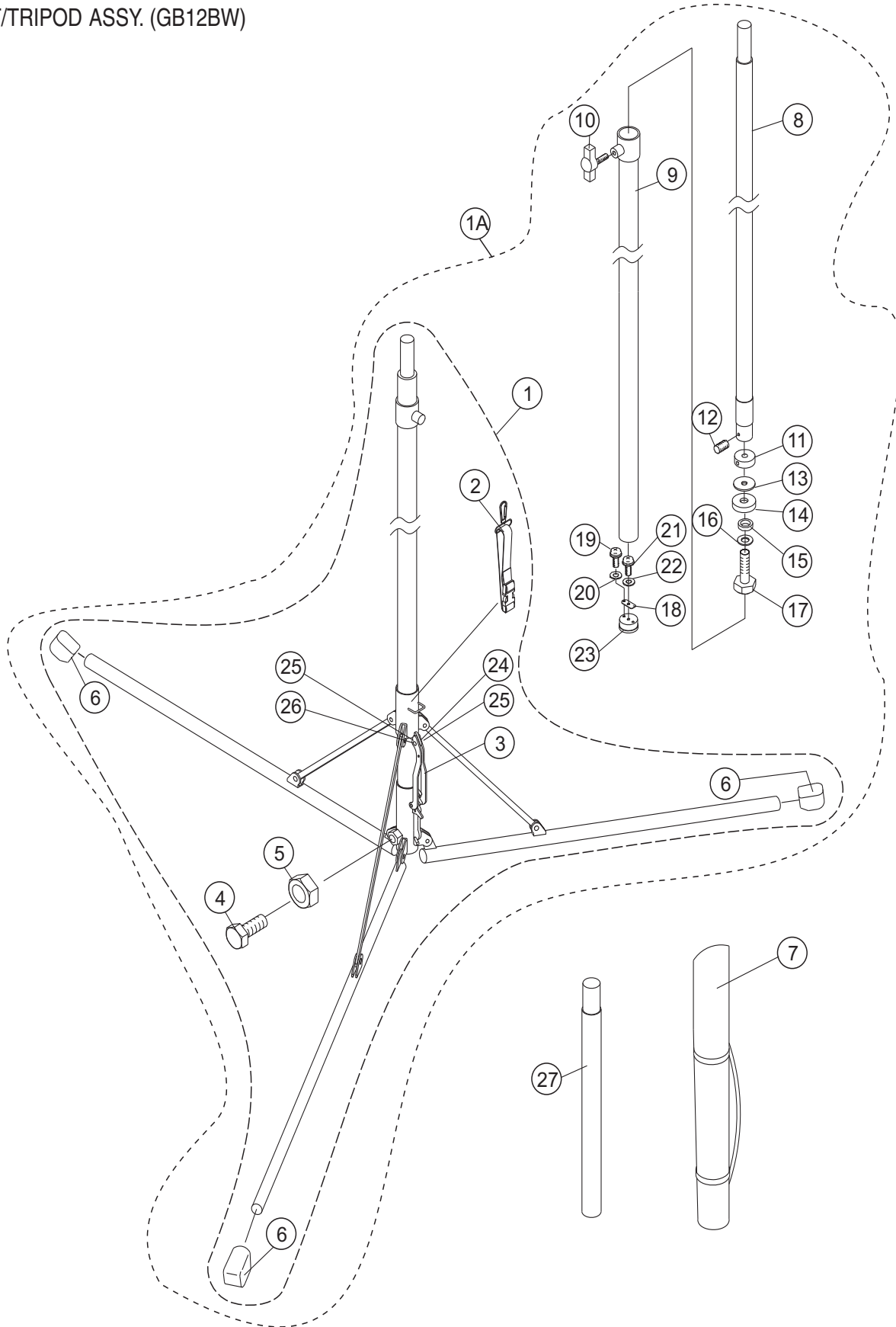

GB12BW/BS/BP LIGHTING SYSTEM — MAST/TRIPOD ASSY. (GB12BW)

MAST/TRIPOD ASSY. (GB12BW)

<u>NO.</u>	<u>PART NO.</u>	<u>PART NAME</u>	<u>QTY.</u>	<u>REMARKS</u>
1A	A000019600	TRIPOD, ASSY.	1	INCLUDES ITEM W/*
1*	A200039900	TRIPOD, FOOT ONLY	1	INCLUDES ITEM W/#
2*#	A300106500	TRIPOD, BAND	1	
3*#	A300108700	SHACKLE, CP	1	
4*#	E000042900	BOLT, (M10 X 20)	1	
5*#	A000018700	LOW NUT, M10	1	
6*#	1641000330	RUBBER, (OUT, R)	3	
7	A300131500	TRIPOD COVER	1	
8*	A000017303	SECOND MAST	1	
9*	A000017201	FIRST MAST	1	
10*	E000044001	KNOB, M10	1	
11*	A400092401	BOTTOM PLATE	1	
12*	0024705008	SET SCREW, (M5 X 8)	2	
13*	A400092801	WASHER, SECOND MAST	1	
14*	A400109600	RUBBER, (MAST)	1	
15*	A400110200	WASHER, (MAST) 1	1	
16*	0043108000	WASHER, M8	1	
17*	0013108030	BOLT, (M8 X 30)	1	
18*	A400112700	LEAF VALVE	1	
19*	0023104008	SCREW, (M4 X 8)	1	
20*	0043104000	WASHER, M4	1	
21*	0023105008	SCREW (M5 X 8)	1	
22*	0043105000	WASHER, M5	1	
23*	A000017000	PLUG	1	
24*#	A000018800	BUTTON SCREW, (M8 X 25)	1	
25*#	A000019000	WASHER, M8	2	
26*#	A000018900	SELFLOCK NUT, M8	1	
27	A300108400	POLE, EXT. 35" (889 MM) OPTIONAL	1	

GB12BW/BS/BP LIGHTING SYSTEM — FAN BLOWER/LAMP BASE ASSY.

FAN BLOWER/LAMP BASE ASSY. (GB12BP)

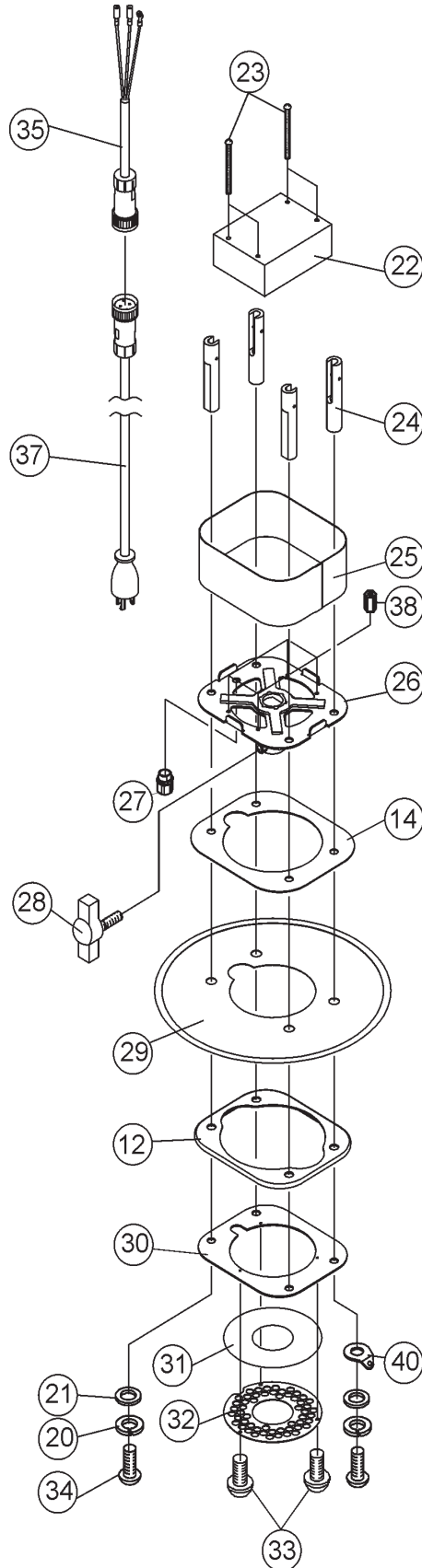

GB12BW/BS/BP LIGHTING SYSTEM — FAN BLOWER/LAMP BASE ASSY.

FAN BLOWER/LAMP BASE ASSY. (GB12BP)

<u>NO.</u>	<u>PART NO.</u>	<u>PART NAME</u>	<u>QTY.</u>	<u>REMARKS</u>
12	2214500130	SEAL, PACKING	2	
14	2214500230	SEAL, FLAT	1	
20	0043210000	WASHER, LOCK (M10)	8	
21	0043110000	WASHER, FLAT	8	
22	A300135300	ELECTRICAL BALLAST	1	
23	0023304055	SCREW AND WASHER (M4 X 55)	4	
24	A400074801	POLE JOINT, 1	4	
25	A300063001	VESSEL	1	
26	A200028002	FLANGE	1	
27	E000035000	CABLE CLAMP	1	
28	E000030000	T-HANDLE KNOB	1	
29	2214521010	SHEET, BOTTOM	1	
30	2214020130	PLATE, BOTTOM	1	
31	2214500430	FILTER, MF-13-10t	1	
32	2214040230	PLATE, AIR	1	
33	0023303006	SCREW & WASHER (M3 X 6)	3	
34	0014710035	BUTTON SCREW, (M10 X 35)	4	
35	A300135600	CABLE, (MAIN 2A) CP	1	
37	A300135500	AC CABLE	1	
38	E000034900	SUPPORT, NUT ASB-410	4	
40	2204510110	WASHER	1	

GB12BW/BS/BP LIGHTING SYSTEM — BALLOON/LAMP GUARD ASSY.

BALLOON/LAMP GUARD ASSY. (GB12BP)

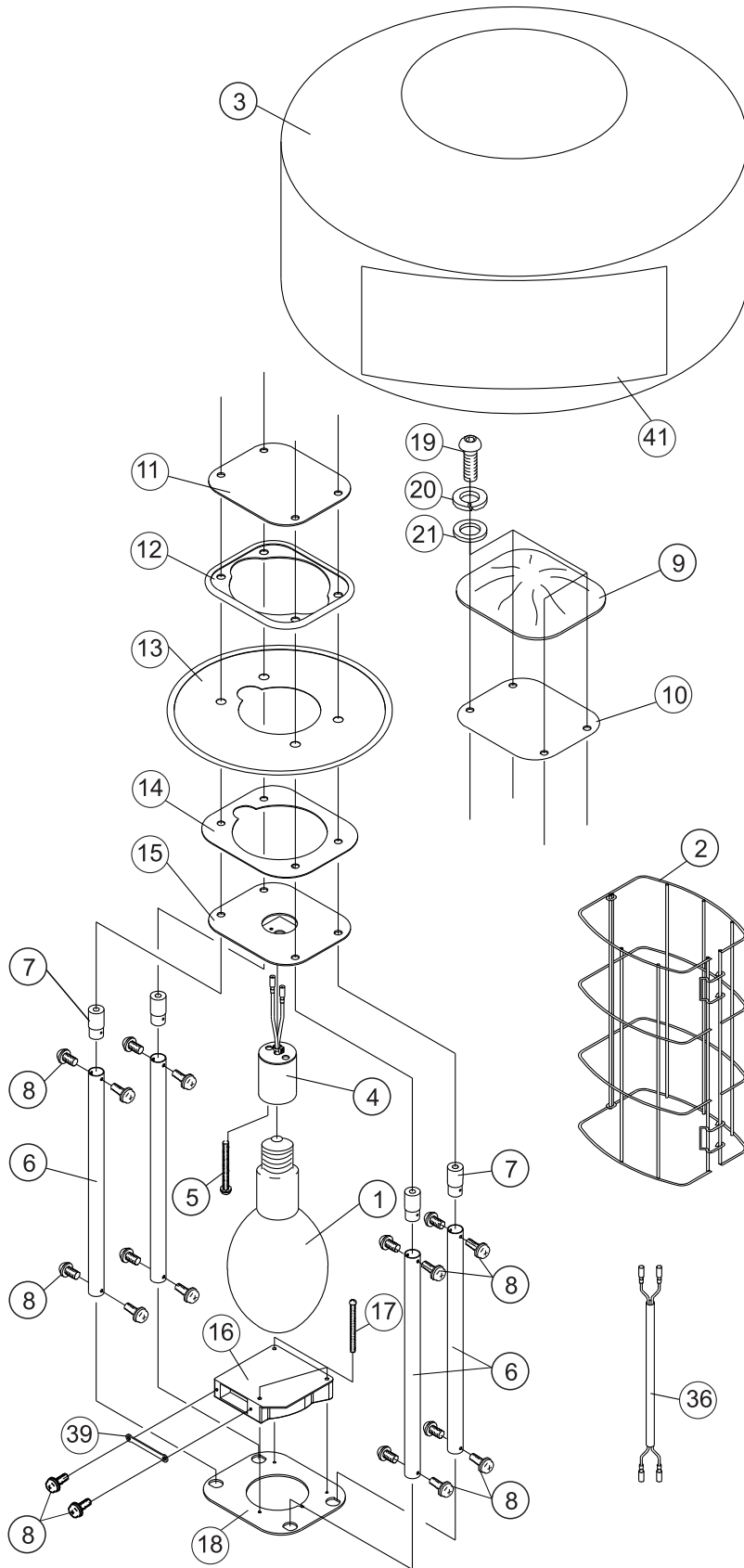

GB12BW/BS/BP LIGHTING SYSTEM — BALLOON/LAMP GUARD ASSY.

BALLOON/LAMP GUARD ASSY. (GB12BP)

<u>NO.</u>	<u>PART NO.</u>	<u>PART NAME</u>	<u>QTY.</u>	<u>REMARKS</u>
1	E000031700	LAMP, MH400/C/U	1	
2	2214420411	LAMP GUARD	1	
3	A100015901	BALLOON CLOTH, CP	1	
4	E000009601	SOCKET ASSY.	1	
5	0025304025	SCREW AND WASHER (M4 X 25)	2	
6	2214401230	FRAME PIPE	4	
7	A400071400	POLE JOINT, 2	4	
8	00243040008	SCREW, (M4 X 8)	18	
9	A100048000	BALLON COVER	1	
10	A300062300	SEAL, TOP	1	
11	2214210330	PLATE, TOP	1	
12	2214500130	SEAL, PACKING	2	
13	2214520210	SHEET, TOP	1	
14	2214500230	SEAL, FLAT	1	
15	A300060600	PLATE, LAMP	2	
16	A300075300	FAN MOTOR, ASSY.	1	
17	0025304035	SCREW AND WASHER (M4 X 35)	3	
18	A300063103	PLATE, FAN	1	
19	0014710025	BUTTON SCREW, (M10 X 25)	4	
20	0043210000	WASHER, LOCK (M10)	8	
21	0043110000	WASHER, FLAT	8	
36	A300075200	LAMP CABLE	1	
39	A400091900	GUARD, FAN	1	
41	GBBALD1	BLANK MESSAGE STRIP, OPTIONAL	1	CONTACT MQ UNIT SALES

GB12BW/BS/BP LIGHTING SYSTEM — OFFSET POLE ASSY. (GB12BS)

OFFSET POLE ASSY. (GB12BS)

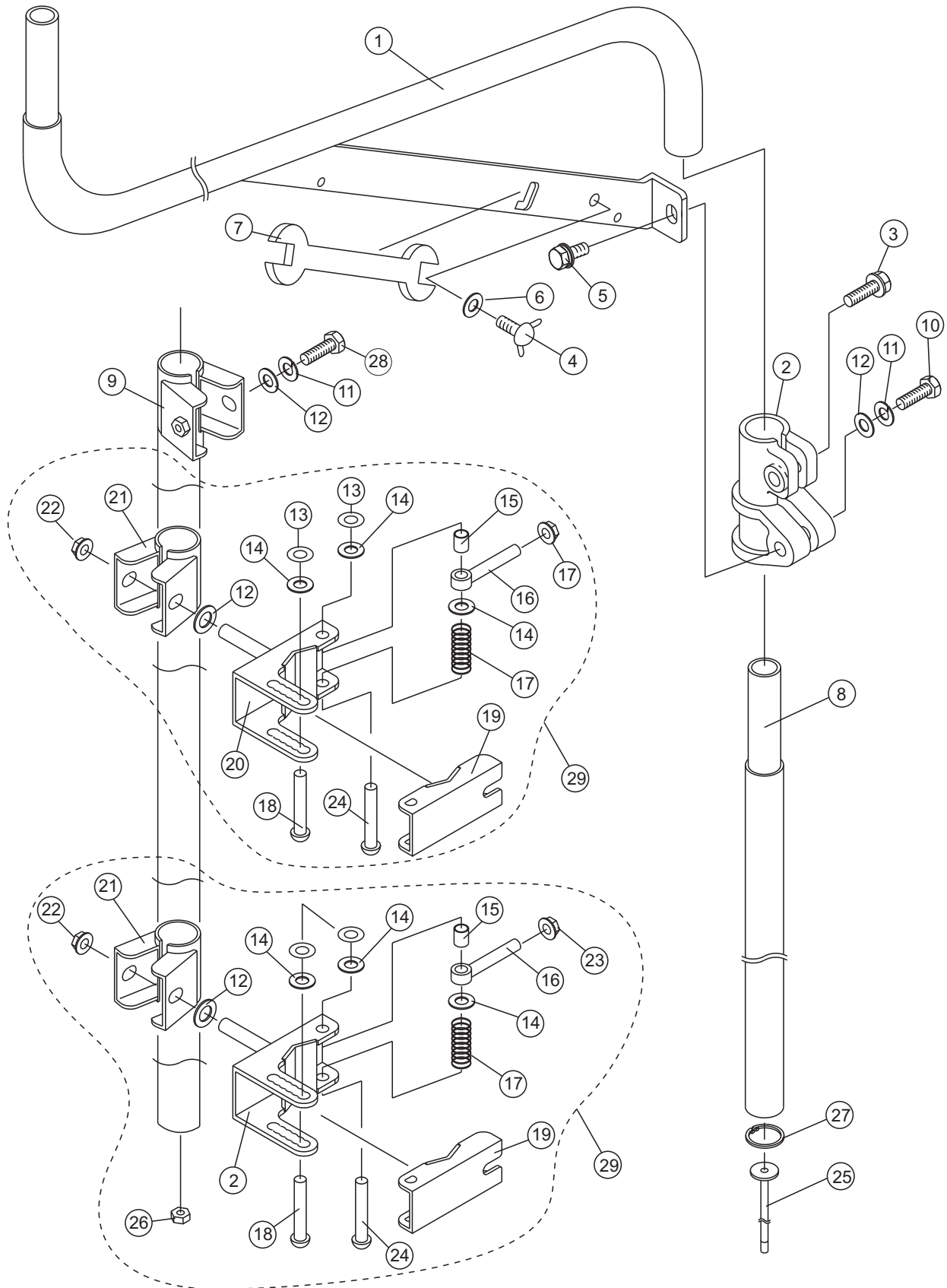

GB12BW/BS/BP LIGHTING SYSTEM — OFFSET POLE ASSY.(GB12BS)

OFFSET POLE ASSY. (GB12BS)

<u>NO.</u>	<u>PART NO.</u>	<u>PART NAME</u>	<u>QTY.</u>	<u>REMARKS</u>
1	A200019103	OFFSET POLE	1	
2	A200018303	ADAPTER (OFFSET PIPE)	1	
3	0013512045	BOLT AND WASHER (M12X45)	1	
4	0014210025	WING BOLT (M10X25)	1	
5	0013510025	BOLT AND WASHER (M10X25)	1	
6	0043110026	WASHER (M10)	1	
7	E000028100	17/19 MM WRENCH	1	
8	A300040904	POLE 2	1	
9	A200021902	POLE 1	1	
10	0013112055	BOLT (M12X55)	1	
11	0043212000	SPRING WASHER (M12)	2	
12 #	0043112000	WASHER (M12)	4	
13 #	0030810000	PUSH NUT (M10)	4	
14 #	0043110000	WASHER (M10)	6	
15 #	E000028300	SPACER	2	
16 #	E000028401	BOLT (M10X80)	2	
17 #	A400067600	SPRING	2	
18 #	A400061500	RIVET	2	
19 #	A300053901	CLAMP 1	2	
20 #	A200025203	CLAMP 2	2	
21 #	A300043601	BAND (POLE) 3T	2	
22 #	E000042101	NUT (M12)	2	
23 #	E000042001	NUT (M10)	2	
24 #	0054010060	RIVET (10-60)	2	
25	A400082101	SHAFT (STOPPER) CP	1	
26	0033206000	SELF LOCK NUT (M6)	1	
27	0040825000	C-CLIP	1	
28	0013112065	BOLT (M12X65)	1	
29	A000025300	POLE CLAMP ASSEMBLY	2	INCLUDES ITEMS W/ #

PAYMENT TERMS

Terms of payment for parts are net 30 days.

FREIGHT POLICY

All parts orders will be shipped collect or prepaid with the charges added to the invoice. All shipments are F.O.B. point of origin. Multiquip's responsibility ceases when a signed manifest has been obtained from the carrier, and any claim for shortage or damage must be settled between the consignee and the carrier.

MINIMUM ORDER

The minimum charge for orders from Multiquip is \$15.00 net. Customers will be asked for instructions regarding handling of orders not meeting this requirement.

RETURNED GOODS POLICY

Return shipments will be accepted and credit will be allowed, subject to the following provisions:

1. A Returned Material Authorization must be approved by Multiquip prior to shipment.
2. To obtain a Return Material Authorization, a list must be provided to Multiquip Parts Sales that defines item numbers, quantities, and descriptions of the items to be returned.
 - a. The parts numbers and descriptions must match the current parts price list.
 - b. The list must be typed or computer generated.
 - c. The list must state the reason(s) for the return.
 - d. The list must reference the sales order(s) or invoice(s) under which the items were originally purchased.
 - e. The list must include the name and phone number of the person requesting the RMA.
3. A copy of the Return Material Authorization must accompany the return shipment.
4. Freight is at the sender's expense. All parts must be returned freight prepaid to Multiquip's designated receiving point.

5. Parts must be in new and resalable condition, in the original Multiquip package (if any), and with Multiquip part numbers clearly marked.
6. The following items are not returnable:
 - a. Obsolete parts. (If an item is in the price book and shows as being replaced by another item, it is obsolete.)
 - b. Any parts with a limited shelf life (such as gaskets, seals, "O" rings, and other rubber parts) that were purchased more than six months prior to the return date.
 - c. Any line item with an extended dealer net price of less than \$5.00.
 - d. Special order items.
 - e. Electrical components.
 - f. Paint, chemicals, and lubricants.
 - g. Decals and paper products.
 - h. Items purchased in kits.
7. The sender will be notified of any material received that is not acceptable.
8. Such material will be held for five working days from notification, pending instructions. If a reply is not received within five days, the material will be returned to the sender at his expense.
9. Credit on returned parts will be issued at dealer net price at time of the original purchase, less a 15% restocking charge.
10. In cases where an item is accepted, for which the original purchase document can not be determined, the price will be based on the list price that was effective twelve months prior to the RMA date.
11. Credit issued will be applied to future purchases only.

PRICING AND REBATES

Prices are subject to change without prior notice. Price changes are effective on a specific date and all orders received on or after that date will be billed at the revised price. Rebates for price declines and added charges for price increases will not be made for stock on hand at the time of any price change.

Multiquip reserves the right to quote and sell direct to Government agencies, and to Original Equipment Manufacturer accounts who use our products as integral parts of their own products.

SPECIAL EXPEDITING SERVICE

A \$35.00 surcharge will be added to the invoice for special handling including bus shipments, insured parcel post or in cases where Multiquip must personally deliver the parts to the carrier.

LIMITATIONS OF SELLER'S LIABILITY

Multiquip shall not be liable hereunder for damages in excess of the purchase price of the item with respect to which damages are claimed, and in no event shall Multiquip be liable for loss of profit or good will or for any other special, consequential or incidental damages.

LIMITATION OF WARRANTIES

No warranties, express or implied, are made in connection with the sale of parts or trade accessories nor as to any engine not manufactured by Multiquip. Such warranties made in connection with the sale of new, complete units are made exclusively by a statement of warranty packaged with such units, and Multiquip neither assumes nor authorizes any person to assume for it any other obligation or liability whatever in connection with the sale of its products. Apart from such written statement of warranty, there are no warranties, express, implied or statutory, which extend beyond the description of the products on the face hereof.

OPERATION AND PARTS MANUAL

HERE'S HOW TO GET HELP

PLEASE HAVE THE MODEL AND SERIAL
NUMBER *ON-HAND* WHEN CALLING

UNITED STATES

Multiquip Corporate Office

18910 Wilmington Ave. Tel. (800) 421-1244
Carson, CA 90746 Fax (800) 537-3927
Contact: mq@multiquip.com

Mayco Parts

800-306-2926 Fax: 800-672-7877
310-537-3700 Fax: 310-637-3284

Service Department

800-421-1244 Fax: 310-537-4259
310-537-3700

MQ Parts Department

800-427-1244 Fax: 800-672-7877
310-537-3700 Fax: 310-637-3284

Warranty Department

800-421-1244, Ext. 279 Fax: 310-537-1173
310-537-3700, Ext. 279

Technical Assistance

800-478-1244 Fax: 310-631-5032

MEXICO

MQ Cipsa

Carr. Fed. Mexico-Puebla KM 126.5 Tel: (52) 222-225-9900
Momoxpan, Cholula, Puebla 72760 Mexico Fax: (52) 222-285-0420
Contact: pmastretta@cipsa.com.mx

CANADA

Multiquip

4110 Industriel Boul. Tel: (450) 625-2244
Laval, Quebec, Canada H7L 6V3 Fax: (450) 625-8664
Contact: jmartin@multiquip.com

UNITED KINGDOM

Multiquip (UK) Limited Head Office

Hanover Mill, Fitzroy Street, Tel: 0161 339 2223
Ashton-under-Lyne, Fax: 0161 339 3226
Lancashire OL7 0TL
Contact: sales@multiquip.co.uk

BRAZIL

Multiquip

Av. Evandro Lins e Silva, 840 - grupo 505 Tel: 011-55-21-3433-9055
Barra de Tijuca - Rio de Janeiro Fax: 011-55-21-3433-9055
Contact: cnavarro@multiquip.com.br, srentes@multiquip.com.br

© COPYRIGHT 2008, MULTIQUIP INC.

Multiquip Inc. and the MQ logo are registered trademarks of Multiquip Inc. and may not be used, reproduced, or altered without written permission. All other trademarks are the property of their respective owners and used with permission.

This manual MUST accompany the equipment at all times. This manual is considered a permanent part of the equipment and should remain with the unit if resold.

The information and specifications included in this publication were in effect at the time of approval for printing. Illustrations, descriptions, references and technical data contained in this manual are for guidance only and may not be considered as binding. Multiquip Inc. reserves the right to discontinue or change specifications, design or the information published in this publication at any time without notice and without incurring any obligations.

Your Local Dealer is:

