

# OPERATION AND PARTS MANUAL



## **GLOBUG MODEL GB2000 LIGHT TOWER MOUNT TYPE BALLOON LIGHT**

Revision #4 (10/07/19)

To find the latest revision of this  
publication, visit our website at:  
[www.multiquip.com](http://www.multiquip.com)



**THIS MANUAL MUST ACCOMPANY THE EQUIPMENT AT ALL TIMES.**

**PROPOSITION 65 WARNING**

---



# TABLE OF CONTENTS

## GB2000 Balloon Light

Proposition 65 Warning .....	2
Table of Contents.....	3
Safety Information .....	4–11
Specifications .....	12
Dimensions.....	13
Footcandle Plot.....	14
General Information.....	15
Type 1 Components (S/N G1900118 and Below).....	16
Type 2 Components (S/N G1900119 and Above) .....	17
Type 1 Setup (S/N G1900118 and Below).....	18–20
Type 2 Setup (S/N G1900119 and Above) .....	21–25
Lamp Lighting Options.....	26–31
Operation.....	32–33
Maintenance .....	34–36
Wiring Diagram.....	37
Explanation of Code in Remarks Column.....	38
Suggested Spare Parts .....	39

## Component Drawings

Electrical Assembly .....	40–43
Bracket and J-Box Assembly (S/N G1900118 and Below).....	44–45
Bracket and J-Box Assembly (S/N G1900119 and Above) .....	46–47

### NOTICE

Specifications and part numbers are subject to change without notice.

# SAFETY INFORMATION

Do not operate or service the equipment before reading the entire manual. Safety precautions should be followed at all times when operating this equipment. Failure to read and understand the safety messages and operating instructions could result in injury to yourself and others.

## SAFETY MESSAGES







The four safety messages shown below will inform you about potential hazards that could injure you or others. The safety messages specifically address the level of exposure to the operator and are preceded by one of four words: **DANGER**, **WARNING**, **CAUTION** or **NOTICE**.

### SAFETY SYMBOLS

 <b>DANGER</b>
Indicates a hazardous situation which, if not avoided, <b>WILL</b> result in <b>DEATH</b> or <b>SERIOUS INJURY</b> .
 <b>WARNING</b>
Indicates a hazardous situation which, if not avoided, <b>COULD</b> result in <b>DEATH</b> or <b>SERIOUS INJURY</b> .
 <b>CAUTION</b>
Indicates a hazardous situation which, if not avoided, <b>COULD</b> result in <b>MINOR</b> or <b>MODERATE INJURY</b> .
<b>NOTICE</b>
Addresses practices not related to personal injury.

## SAFETY SYMBOLS

Potential hazards associated with the operation of this equipment will be referenced with hazard symbols which may appear throughout this manual in conjunction with safety messages.

Symbol	Safety Hazard
	Lethal exhaust gas hazards
	Explosive fuel hazards
	Burn hazards
	Overspeed hazards
	Rotating parts hazards
	Pressurized fluid hazards
	Electric shock hazards

# SAFETY INFORMATION

## GENERAL SAFETY

### CAUTION

- **NEVER** operate this equipment without proper protective clothing, shatterproof glasses, respiratory protection, hearing protection, steel-toed boots and other protective devices required by the job or city and state regulations.



- **NEVER** operate this equipment when not feeling well due to fatigue, illness or when under medication.



- **NEVER** operate this equipment under the influence of drugs or alcohol.



- **ALWAYS** check the equipment for loosened threads or bolts before starting.
- **DO NOT** use the equipment for any purpose other than its intended purposes or applications.

### NOTICE

- This equipment should only be operated by trained and qualified personnel 18 years of age and older.
- Whenever necessary, replace nameplate, operation and safety decals when they become difficult read.
- Manufacturer does not assume responsibility for any accident due to equipment modifications. Unauthorized equipment modification will void all warranties.
- **NEVER** use accessories or attachments that are not recommended by Multiquip for this equipment. Damage to the equipment and/or injury to user may result.

- **ALWAYS** know the location of the nearest fire extinguisher.



- **ALWAYS** know the location of the nearest first aid kit.



- **ALWAYS** know the location of the nearest phone or keep a phone on the job site. Also, know the phone numbers of the nearest **ambulance**, **doctor** and **fire department**. This information will be invaluable in the case of an emergency.

# SAFETY INFORMATION

## LIGHT TOWER SAFETY

### DANGER

- **NEVER** operate the equipment in an explosive atmosphere or near combustible materials. An explosion or fire could result causing severe **bodily harm or even death.**



### WARNING

- **NEVER** disconnect any **emergency or safety devices.** These devices are intended for operator safety. Disconnection of these devices can cause severe injury, bodily harm or even death. Disconnection of any of these devices will void all warranties.

### CAUTION

- **NEVER** lubricate components or attempt service on a running machine.
- **ALWAYS** ensure light tower is on level ground before use so that it cannot slide or shift around, endangering workers. Always keep immediate area free of bystanders.
- **ALWAYS** make sure trailer is leveled with all outriggers extended before raising tower. Outriggers must remain extended while tower is up.
- **ALWAYS** keep area behind trailer clear of people while raising and lowering mast.
- **NEVER** remove safety pin or pull mast locking pin while tower is in a raised position!
- **CHECK** the mast and winch cables for wear. If any problem occurs when lowering or raising the tower, **STOP** immediately! Contact a trained technician for assistance.
- **NEVER** pivot or retract mast while unit is operating.
- **NEVER** use the light tower mast as a crane. **DO NOT** lift anything with the mast.
- **ALWAYS** lower the light tower when not in use, or if high winds or electrical storms are expected.

### NOTICE

- **ALWAYS** keep the immediate area surrounding the light tower clean, neat, and free of debris.
- **ALWAYS** keep the machine in proper running condition.
- Fix damage to machine and replace any broken parts immediately.
- **ALWAYS** store equipment properly when it is not being used. Equipment should be stored in a clean, dry location out of the reach of children and unauthorized personnel.
- To prevent the light tower from overturning, **NEVER** use in winds that exceed **65 MPH (105 km/h).**

## LAMP SAFETY

### WARNING

- **NEVER** attempt to replace lamp with the power on. Always shut down the engine and turn off circuit breakers when changing the lamp.
- **ALWAYS** allow a sufficient amount of time for the lamp to **cool** before touching or changing. The possibility exists of severe burns.

### CAUTION

- **NEVER** use force when installing the lamp. Excessive force could cause the lamp to break, causing bodily harm.

### NOTICE

- **NEVER** leave any grease or oil residue on lamp surface when replacing or removing lamp. This can create hot spots, reducing the service life of the lamp.
- **ALWAYS** make sure lamp surface is clean and dry.
- **ALWAYS** replace with MQ recommended type lamp.
- **ALWAYS** have a **trained technician** install and remove a floodlight, or replace any damaged fixture wiring.

# SAFETY INFORMATION

## ENGINE SAFETY

### DANGER

- The engine fuel exhaust gases contain poisonous carbon monoxide. This gas is colorless and odorless, and can cause death if inhaled.
- The engine of this equipment requires an adequate free flow of cooling air. **NEVER** operate this equipment in any enclosed or narrow area where free flow of the air is restricted. If the air flow is restricted it will cause injury to people and property and serious damage to the equipment or engine.

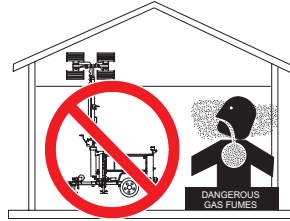

### WARNING

- **DO NOT** place hands or fingers inside engine compartment when engine is running.
- **NEVER** operate the engine with heat shields or guards removed.
- Keep fingers, hands hair and clothing away from all moving parts to prevent injury.
- **DO NOT** remove the radiator cap while the engine is hot. High pressure boiling water will gush out of the radiator and severely scald any persons in the general area of the generator.
- **DO NOT** remove the coolant drain plug while the engine is hot. Hot coolant will gush out of the coolant tank and severely scald any persons in the general area of the generator.
- **DO NOT** remove the engine oil drain plug while the engine is hot. Hot oil will gush out of the oil tank and severely scald any persons in the general area of the generator.



### CAUTION

- **NEVER** touch the hot exhaust manifold, muffler or cylinder. Allow these parts to cool before servicing equipment.



## NOTICE

- **NEVER** run engine without an air filter or with a dirty air filter. Severe engine damage may occur. Service air filter frequently to prevent engine malfunction.
- **NEVER** tamper with the factory settings of the engine or engine governor. Damage to the engine or equipment can result if operating in speed ranges above the maximum allowable.
- **NEVER** tip the engine to extreme angles during lifting as it may cause oil to gravitate into the cylinder head, making the engine start difficult.
- Wet stacking is a common problem with diesel engines which are operated for extended periods with light or no load applied. When a diesel engine operates without sufficient load (less than 40% of the rated output), it will not operate at its optimum temperature. This will allow unburned fuel to accumulate in the exhaust system, which can foul the fuel injectors, engine valves and exhaust system, including turbochargers, and reduce the operating performance.



In order for a diesel engine to operate at peak efficiency, it must be able to provide fuel and air in the proper ratio and at a high enough engine temperature for the engine to completely burn all of the fuel.

Wet stacking does not usually cause any permanent damage and can be alleviated if additional load is applied to relieve the condition. It can reduce the system performance and increase maintenance. Applying an increasing load over a period of time until the excess fuel is burned off and the system capacity is reached usually can repair the condition. This can take several hours to burn off the accumulated unburned fuel.

- State Health Safety Codes and Public Resources Codes specify that in certain locations, spark arresters must be used on internal combustion engines that use hydrocarbon fuels. A spark arrester is a device designed to prevent accidental discharge of sparks or flames from the engine exhaust. Spark arresters are qualified and rated by the United States Forest Service for this purpose. In order to comply with local laws regarding spark arresters, consult the engine distributor or the local Health and Safety Administrator.

# SAFETY INFORMATION

## FUEL SAFETY

### DANGER

- **DO NOT** start the engine near spilled fuel or combustible fluids. Diesel fuel is extremely flammable and its vapors can cause an explosion if ignited.
- **ALWAYS** refuel in a well-ventilated area, away from sparks and open flames.
- **ALWAYS** use extreme caution when working with **flammable** liquids.
- **DO NOT** fill the fuel tank while the engine is running or hot.
- **DO NOT** overfill tank, since spilled fuel could ignite if it comes into contact with hot engine parts or sparks from the ignition system.
- Store fuel in appropriate containers, in well-ventilated areas and away from sparks and flames.
- **NEVER** use fuel as a cleaning agent.
- **DO NOT** smoke around or near the equipment. Fire or explosion could result from fuel vapors or if fuel is spilled on a hot engine.



## TOWING SAFETY — LIGHT TOWER

### CAUTION

- Check with your local county or state safety towing regulations, in addition to meeting **Department of Transportation (DOT) Safety Towing Regulations**, before towing your light tower.
- In order to reduce the possibility of an accident while transporting the light tower on public roads, **ALWAYS** make sure the trailer that supports the light tower and the towing vehicle are mechanically sound and in good operating condition.
- **ALWAYS** shutdown engine before transporting.
- Make sure the hitch and coupling of the towing vehicle are rated equal to, or greater than the trailer “gross vehicle weight rating.”



- **ALWAYS** inspect the hitch and coupling for wear. **NEVER** tow a trailer with defective hitches, couplings, chains, etc.
- Check the tire air pressure on both towing vehicle and trailer. **Trailer tires should be inflated to 50 psi cold.** Also check the tire tread wear on both vehicles.
- **ALWAYS** make sure the trailer is equipped with a **safety chain**.
- **ALWAYS** properly attach trailer’s safety chains to towing vehicle.
- **ALWAYS** make sure the vehicle and trailer directional, backup, brake and trailer lights are connected and working properly.
- DOT Requirements include the following:
  - Connect and test electric brake operation.
  - Secure portable power cables in cable tray with tie wraps.
- The maximum speed for highway towing is **55 MPH (86 km/h)** unless posted otherwise. Recommended off-road towing is not to exceed **15 MPH (24 km/h)** or less depending on type of terrain.
- Avoid sudden stops and starts. This can cause skidding, or jack-knifing. Smooth, gradual starts and stops will improve towing.
- Avoid sharp turns to prevent rolling.
- Trailer should be adjusted to a level position at all times when towing.
- Raise and lock trailer jack stands in up position when towing.

### NOTICE

**ALWAYS remove** and **stow** the GB2000 lamp fixture prior to towing the light tower.



# SAFETY INFORMATION

## TRANSPORTING SAFETY

### ⚠ CAUTION

- Before lifting, make sure that light tower parts are not damaged and screws are not loosened or lost.
- **ALWAYS** make sure crane or lifting device has been properly secured to lifting hook of the equipment.
- **NEVER** lift the equipment while engine is running.
- Remove fan power cord from junction box before towing.
- Make sure tower (mast) is in the stowed position and the GB2000 is removed from the mast before lifting.

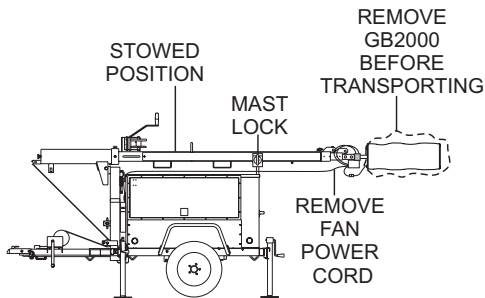

- **ALWAYS** Make sure rear mast lock is secure before lifting.
- Use adequate lifting cable (wire or rope) of sufficient strength.
- Use one point suspension hook and lift straight upwards.

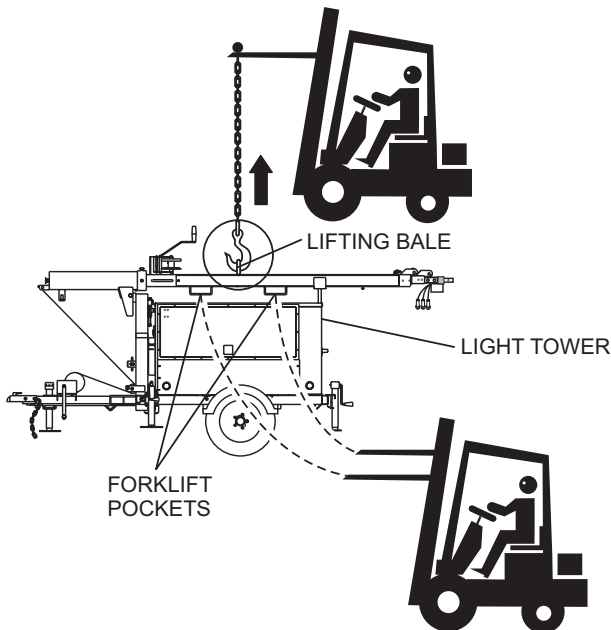

- If lifting through pockets, make sure forks of forklift are inserted in pockets as far as possible before lifting.
- Place **chock blocks** underneath wheel to prevent **rolling** while parked.
- Place **support blocks** underneath the trailer's bumper to prevent **tipping** while parked.
- Use the trailer's swivel jack to adjust the trailer height to a level position while parked.
- **NEVER** allow any person or animal to stand underneath the equipment while lifting.
- **DO NOT** lift equipment to unnecessary heights.

## Loading and Tie-Down on Flatbed Truck

### NOTICE

- Before loading light tower to flatbed truck, disconnect all connectors and tie-wrap the cables against the T-bar to prevent damage to the cables and connectors.
- Remove and stow the GB2000 in a safe place where it will not get damaged before loading the light tower onto a flatbed truck, towing, or shipping via a container.
- When loading onto flatbed truck, make sure that front jackstand of light tower is retracted and in the horizontal position so that the foot does not make contact with the deck floor.

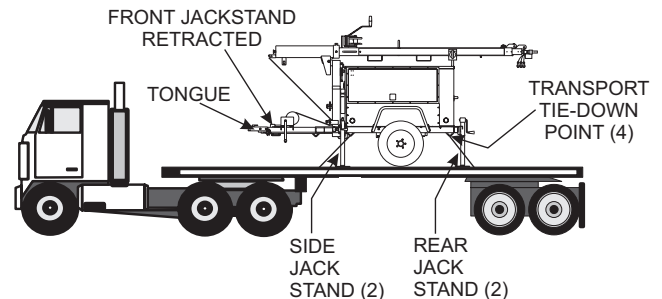

- Make sure that the two side (left and right) and two rear jackstands are in the vertical position, slightly extended, so that each foot makes contact with the deck floor.
- Straps and chains should be routed through the transport tie-down points located beneath each corner of the cabinet to allow even application of force to the front and rear of the machine.
- **DO NOT** secure the unit by running a strap or chain over the tongue of the light tower. This may cause severe damage to the unit.

# SAFETY INFORMATION

## ELECTRICAL SAFETY

### DANGER

■ The electrical voltage required to operate the generator can cause severe injury or even death through physical contact with live circuits. Turn generator and all circuit breakers **OFF** before performing maintenance on the generator.

■ **NEVER** insert any objects into the output receptacles during operation. This is extremely dangerous. The possibility exists of **electrical shock, electrocution or death.**



■ **NEVER** operate light tower or handle any electrical equipment while standing in water, while barefoot, while hands are wet or in the rain. A dangerous **electrical shock** could occur, causing **severe bodily harm or even death.**

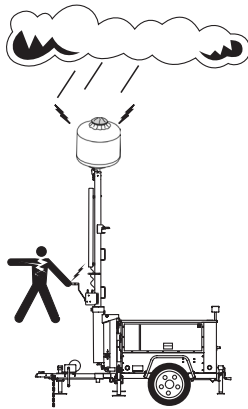

■ **ALWAYS** make sure the area above the light tower is open and clear of overhead power lines and other obstructions. The tower extends in excess of 30 feet (9 meters). Contact with overhead power lines or other obstructions could result in equipment damage, **electrical shock, electrocution and even death.**

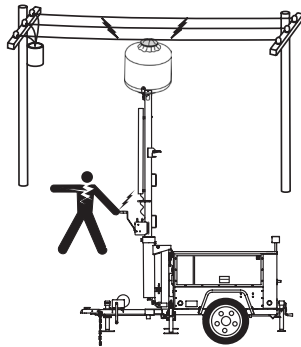

■ Similar to boom equipment, light tower may become energized with high voltage. **DO NOT** operate the light tower within a radial distance of 17 feet (5.1 meters) from high voltage power lines. If light tower becomes energized with high voltage, contact with the equipment could result in electrocution.

■ **NEVER** operate GB2000 in winds in excess of **40 MPH (64 km/h).**

■ Backfeed to a utility system can cause **electrocution** and/or property damage. **NEVER** connect the generator to a building's electrical system without a transfer switch or other approved device. All installations should be performed by a **licensed electrician** in accordance with all applicable laws and electrical codes. Failure to do so could result in electrical shock or burn, causing **serious injury or even death.**



## Power Cord/Cable Safety

### DANGER

■ **NEVER** let power cords or cables lay in water.

■ **NEVER** use **damaged** or **worn** cables or cords when connecting equipment to generator. Inspect for cuts in the insulation.

■ **NEVER** grab or touch a live power cord or cable with wet hands. The possibility exists of **electrical shock, electrocution or death.**

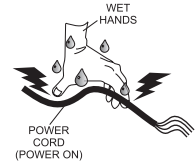

■ Make sure power cables are securely connected. Incorrect connections may cause electrical shock and damage to the light tower.

### NOTICE

■ **ALWAYS** make certain that proper power or extension cord has been selected for the job.

■ Ensure fan power cable is safely routed and secured as it travels from the junction box down the mast to the GFCI receptacle.

## Grounding Safety

### DANGER

■ The light tower is equipped with a ground terminal for your protection. **ALWAYS** complete the grounding path from the light tower to an external grounding source.

■ **ALWAYS** make sure that electrical circuits are properly grounded to a suitable earth ground (ground rod) per the National Electrical Code (NEC) and local codes before operating generator. **Severe injury or death by electrocution** can result from operating an ungrounded generator.

■ **NEVER** use gas piping as an electrical ground.

# SAFETY INFORMATION

## BATTERY SAFETY

### DANGER

- **DO NOT** drop the battery. There is a possibility that the battery will explode.
- **DO NOT** expose the battery to open flames, sparks, cigarettes, etc. The battery contains combustible gases and liquids. If these gases and liquids come into contact with a flame or spark, an explosion could occur.



### WARNING

- **ALWAYS** wear safety glasses when handling the battery to avoid eye irritation. The battery contains acids that can cause injury to the eyes and skin.
- Use well-insulated gloves when picking up the battery.
- **ALWAYS** keep the battery charged. If the battery is not charged, combustible gas will build up.
- **ALWAYS** recharge the battery in a well-ventilated environment to avoid the risk of a dangerous concentration of combustible gasses.
- If the battery liquid (dilute sulfuric acid) comes into contact with **clothing or skin**, rinse skin or clothing immediately with plenty of water.
- If the battery liquid (dilute sulfuric acid) comes into contact with **eyes**, rinse eyes immediately with plenty of water and contact the nearest doctor or hospital to seek medical attention.



### CAUTION

- **ALWAYS** disconnect the **NEGATIVE** battery terminal before performing service on the generator.
- **ALWAYS** keep battery cables in good working condition. Repair or replace all worn cables.

## ENVIRONMENTAL SAFETY

### NOTICE

- Dispose of hazardous waste properly. Examples of potentially hazardous waste are used motor oil, fuel and fuel filters.
- **DO NOT** use food or plastic containers to dispose of hazardous waste.
- **DO NOT** pour waste, oil or fuel directly onto the ground, down a drain or into any water source.



<b>Table 1. Specifications</b>		
Model		GB2000
Lamp	Type	1000 W Metal Halide (X2)
	Number of Bulbs	2
	Current	8.2 A
	Voltage	238 268 V
	Lumens	220,000 lm
Fan	Current	0.87 A
	Voltage	115 V
Dimensions	Storage	12.2 x 12.2 x 39 in (310 x 310 x 990 mm)
	Working	36 x 36 x 39 in (900 x 900 x 990 mm)
Total Weight		31 lb (14 kg)
Appropriate Generator		3.2 kW and above

# DIMENSIONS

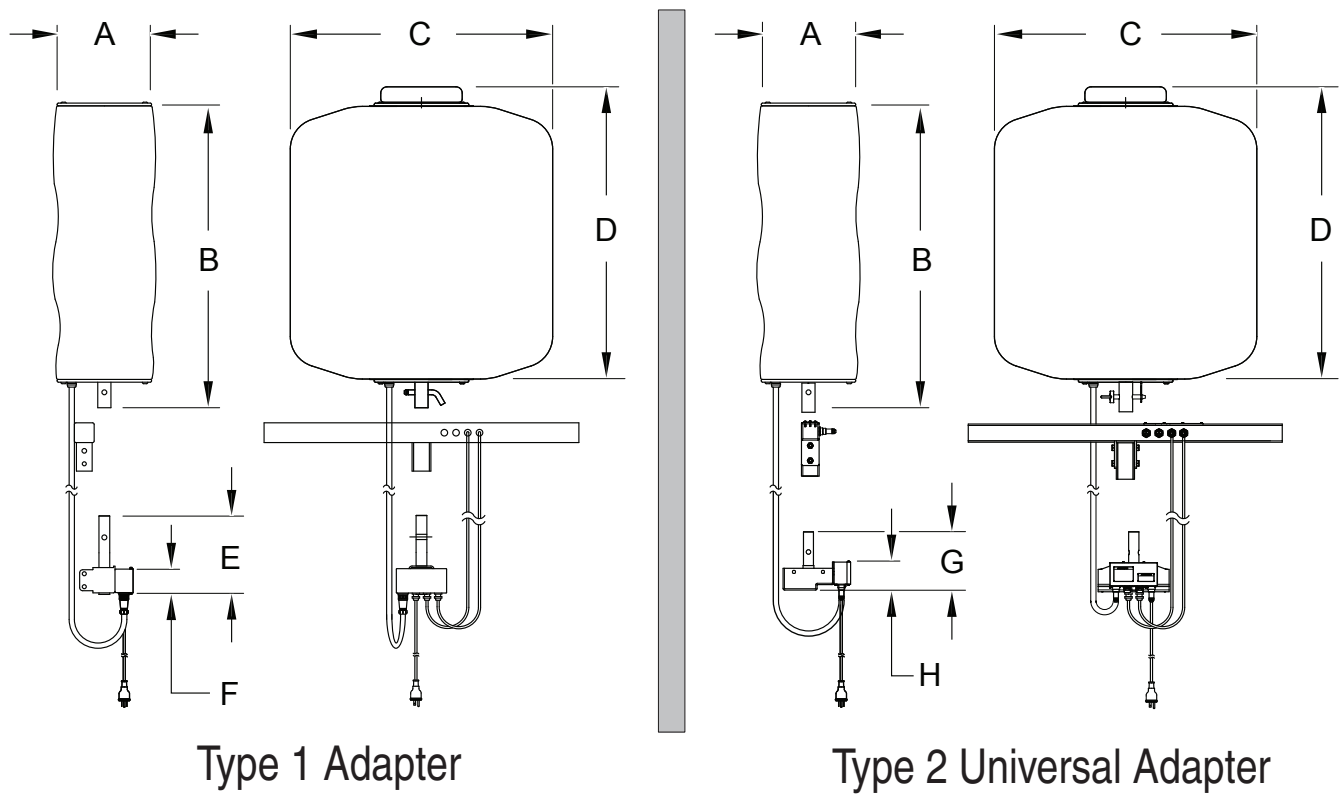
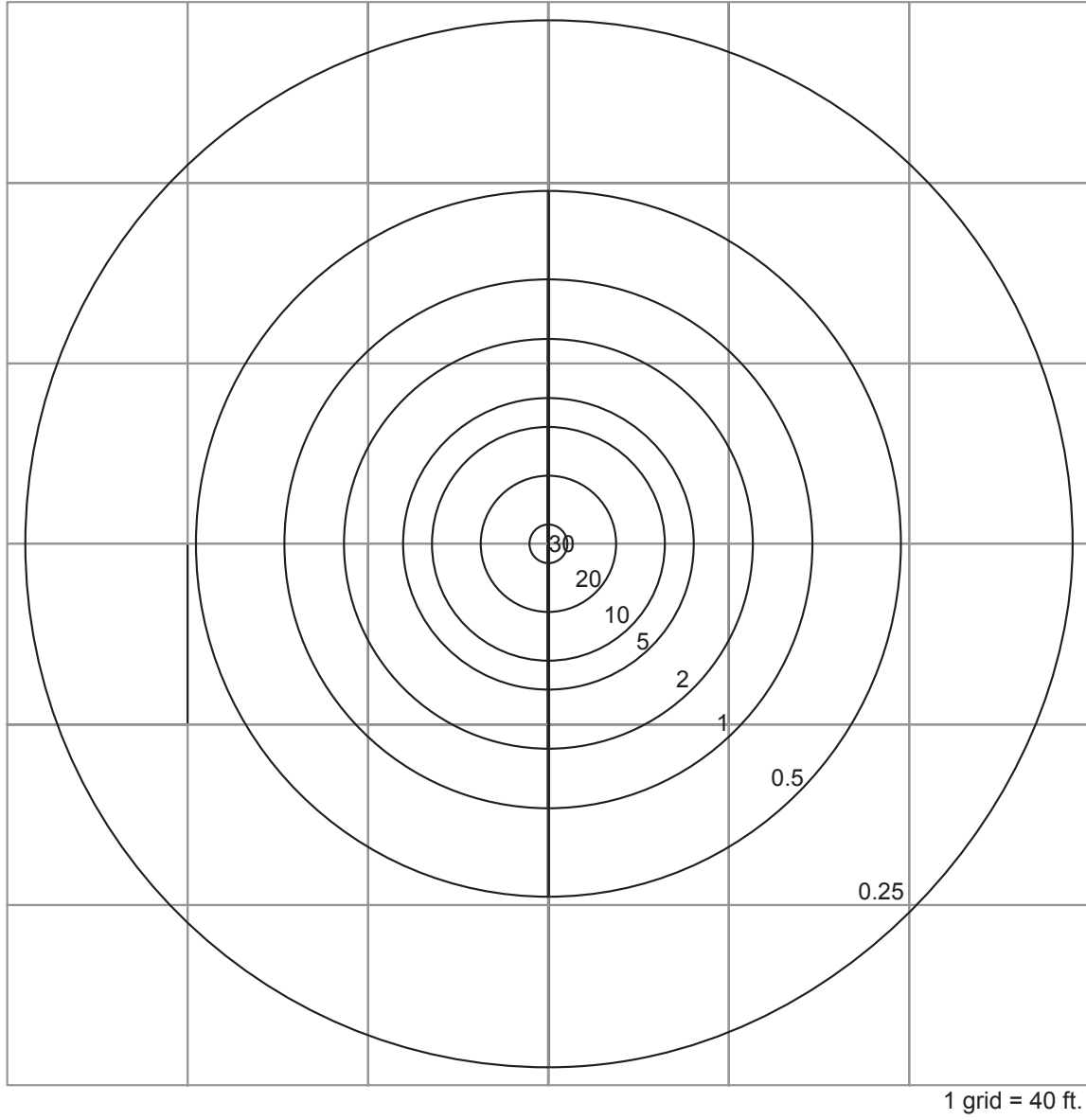

Figure 1. Dimensions

Table 2. Dimensions			
Reference Letter	Dimension in. (mm)	Reference Letter	Dimension in. (mm)
A	13.25 (337)	E	3.12 (79.3)
B	40.0 (1,016)	F	9.75 (248)
C	35.5 (902)	G	8.25 (210)
D	34.5 (876)	H	4.62 (117)

# FOOTCANDLE PLOT



Illuminance (Footcandle)	30	20	10	5	2	1	0.5	0.25
Diameter (Feet)	9	30	52	65	91	117	156	232

**IES\* Recommended Levels of Illumination**

Area	Foot Candles	Area	Foot Candles
Airport	0.5-2	Loading & Unloading	20
Explosives Handling	30	Parking Area	1-5
General Construction	10	Piers	20
Excavation	2	Railroad Yards, Switching	2
Haul Roads and Industrial Roadways	0.5-1	Quarries & Open Pit Mining	5
Industrial Yard/Material Handling	5	Sportsfield & Recreational	10-50

\*Illuminating Engineering Society

**Figure 2. Footcandle Plot**

## GENERAL INFORMATION

---

The GB2000 lamp fixture is a difused balloon light that is designed to be mounted and operated on most convential mobile light tower masts. Its design and features permit clean, difused light to be cast uniformly over 232 feet (70.7 meters).

The shadow-less lighting dramatically reduces glare in the work area. This type of lighting improves safety and enhances the illuminated area. the GB2000 is ideal for highway work, construction job sites, security support, and special events.

The balloon light assembly is supported by two 1000 watt metal halide lamps, self-inflating durable polyester balloon bag, protective lamp guard, quick disconnect communal mast bracket, and self-contained electrical junction box.

Once attached to the mast, the GB2000 utilizes the ballast assembly, electrical conduits, and receptacle connections of conventional mobile light towers to permit operation.

The GB2000 requires 2000 watts of power and the host light tower electrical ballast system for operation. Total lamp operation will be limited to the design and capacity of the host light tower.

The unit easily disconnects from the light tower mast and can be easily stored in its protective canvas cover case.

## TYPE 1 COMPONENTS (S/N G1900118 AND BELOW)

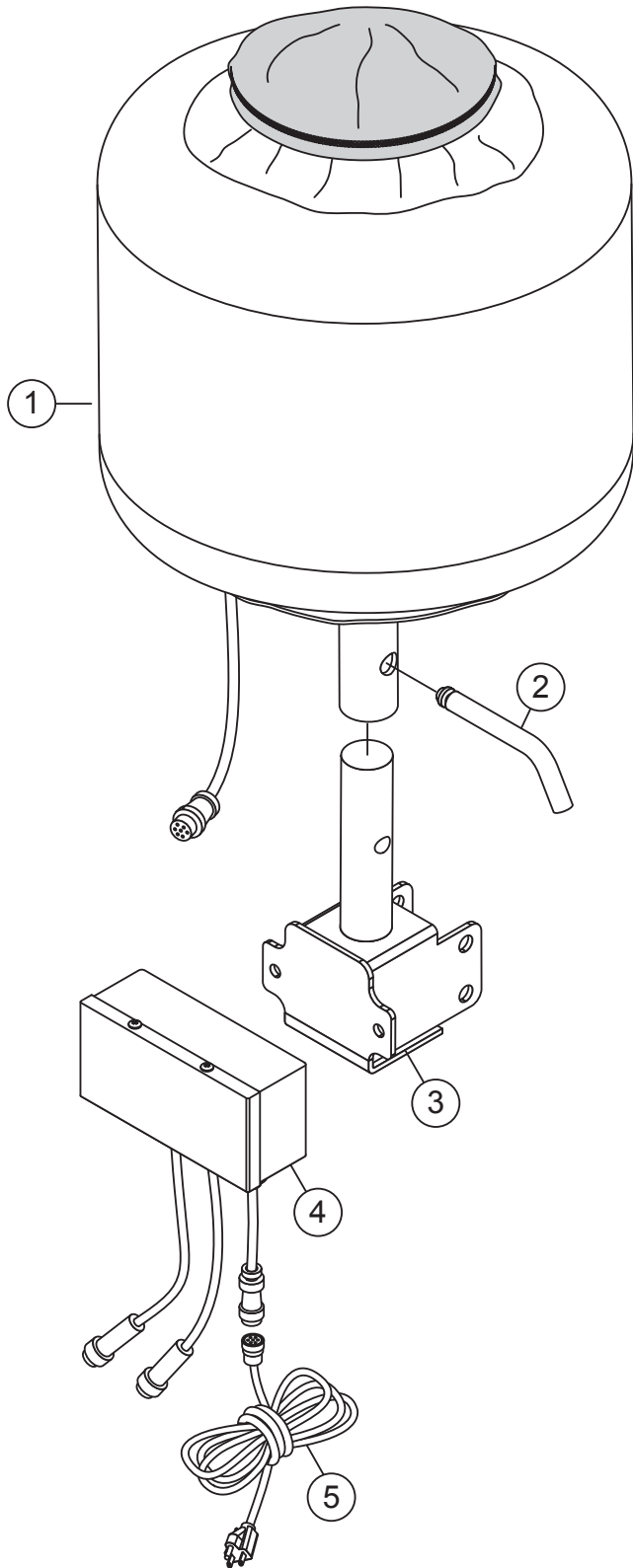

1. **Lamp Fixture** — Made of heat resistant polyester balloon, with a diameter of 35.5 inches (902 mm) and two 1000 watt metal halide lamps.
2. **Locking Pin** — Locks the lamp fixture in place when attached to the pole on the bracket.
3. **Bracket Plate** — Attaches to the Tbar and mast interface of the light tower to allow the GB2000 to be installed.

### NOTICE

This bracket only fits on Multiquip light towers.

4. **Junction Box** — Holds the electrical connection and cables to connect the lamp fixture to the TBar and to the power cable.
5. **Power Cable** — Connects the lamp fixture from the junction box to the GFCI receptacle of the generator to provide power to inflate the balloon.

**Figure 3. GB2000 Components  
(Type 1 S/N G1900118 And Below)**



## TYPE 2 COMPONENTS (S/N G1900119 AND ABOVE)

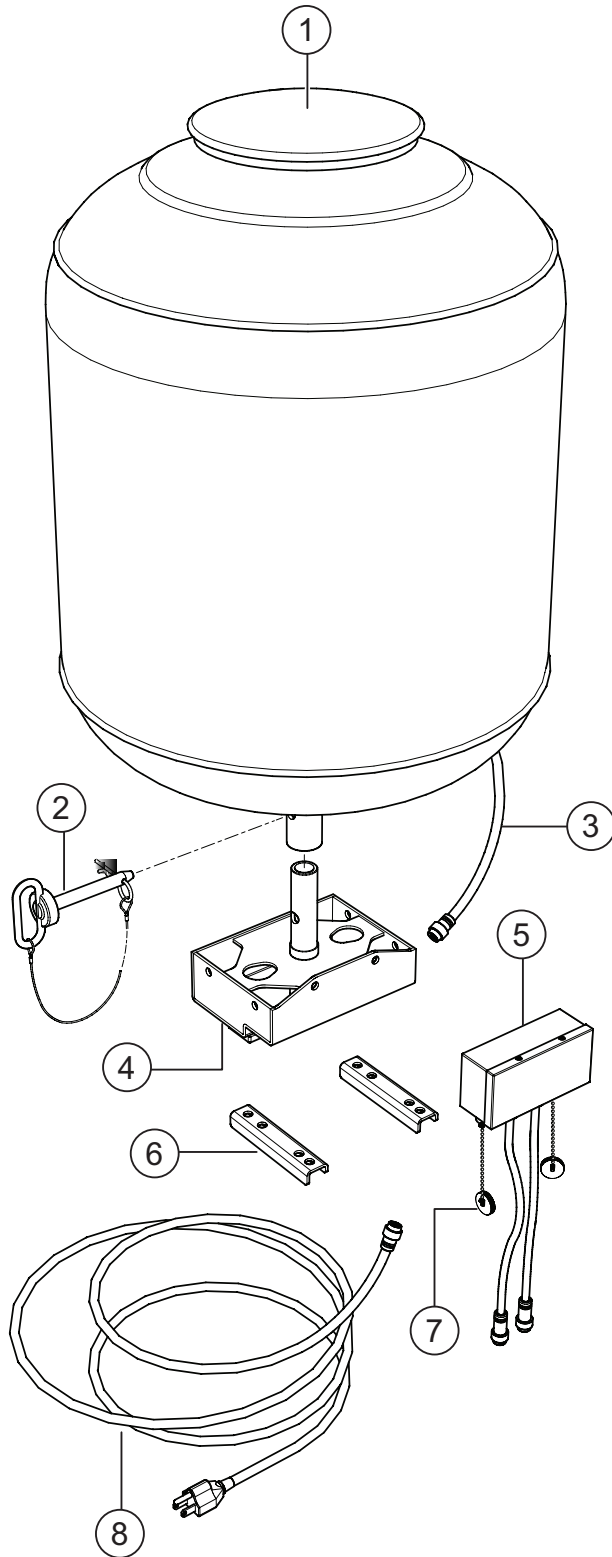

**Figure 4. GB2000 Components**  
(Type 2 S/N G190019 And Above)

1. **Lamp Fixture** — Made of heat resistant polyester balloon, with a diameter of 35.5 inches (902 mm) and two 1000 watt metal halide lamps.
2. **Locking Pin** — Locks the lamp fixture in place when attached to the pole on the bracket.
3. **Balloon Power Cable** — Provides AC power to the lamps, fan and baloon inflation circuit.
4. **Adapter Plate** — Attaches to the T-Bar and mast interface of the light tower to allow the GB2000 to be installed.

### NOTICE

Type 2 adapter plate fits most conventional light tower masts.

5. **Junction Box** — Holds the electrical connection and cables to connect the lamp fixture to the T-Bar and to the power cable.
6. **Support Bracket** — Attaches to T-Bar to support adapter plate (hardware not shown).
7. **Connector Caps** — Provides protection to the receptacles on the junction box when not in use.
8. **Fan Power Cable** — 38 ft. (11.5 meters) cable that provides 120 VAC from a GFCI receptacle (generator) to the T-Bar mounted junction box to run the balloon fan and inflate the balloon.

# TYPE 1 SETUP (S/N G1900118 AND BELOW)

## PREPARATION

1. Place the light tower in an area free of dirt and debris with enough clearance as not to interfere with any overhead obstructions. Make sure it is on secure level ground with chock blocks underneath each wheel to prevent the light tower from rolling.

**! DANGER**

**ALWAYS** make sure the area above light tower is open and clear of overhead power lines and other obstructions. The tower extends in excess of 30 ft. (9 meters). Contact with overhead power lines or other obstructions could result in equipment damage, serious injury or death!

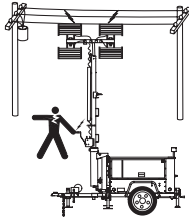

2. If the light tower is in the deployed position, place the tower mast into the cradle support (stowed position). See Figure 5. Make sure cradle lock/release pin has been inserted and the mast is locked.

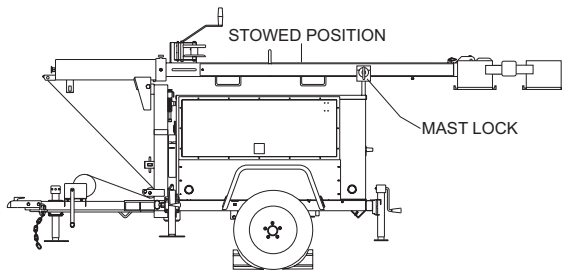

Figure 5. Light Tower in Stowed Position

## DISASSEMBLY

1. For LT12D light towers, disconnect the negative cable (black) from battery. See Figure 6.

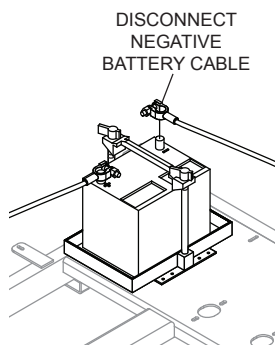

Figure 6. Disconnecting Battery

2. For MLT series light towers disconnect the 4-pin power cable (Figure 7) from the 125 VAC twist-lock receptacle on the front panel of the generator.

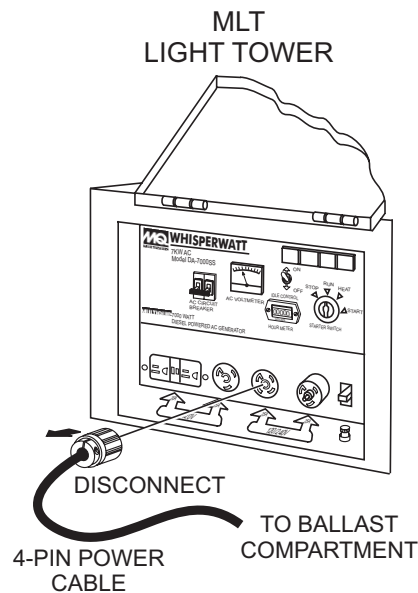

Figure 7. MLT Power Cable Removal

3. Disconnect the lamp power cables from receptacles J1 thru J4 on the T-Bar assembly. See Figure 8.

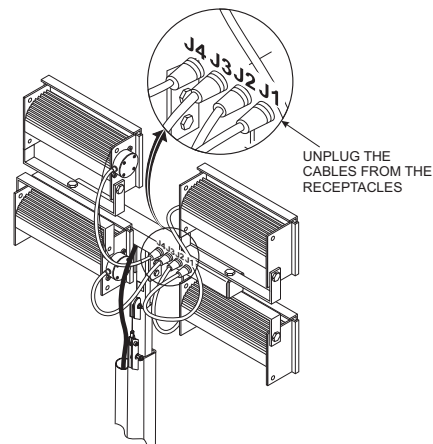
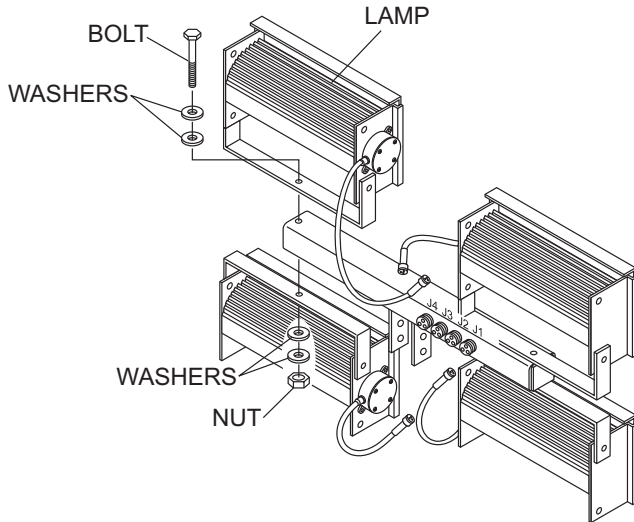

Figure 8. Remove Cables

4. Remove all 4 lamps (Figure 9) from the T-Bar by removing the bolts (with washers and nuts) securing each lamp to the T-Bar.
5. Keep the removed lamps and the associated hardware together and store in a safe place, making sure that the lamps are properly protected to prevent breakage.

# TYPE 1 SETUP (S/N G1900118 AND BELOW)

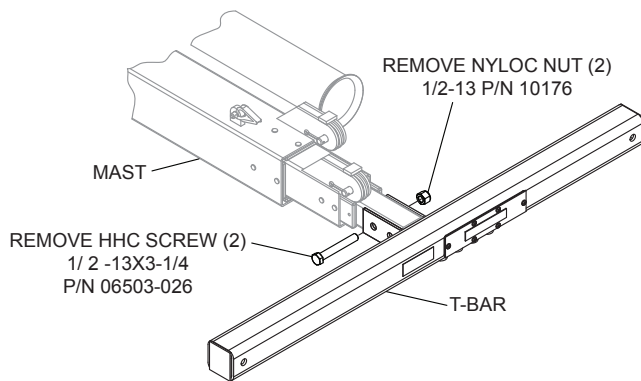

**Figure 9. Lamp Removal**

## ASSEMBLY

**CAUTION**  
 Make sure that the T-bar is supported before removing the two screws and nuts to prevent T-Bar from falling off the mast extension.

1. Remove the 2 screws and 2 nuts that secure the T-Bar to the mast extension. Discard these items they will not be used in the reassembly. See Figure 10.



**Figure 10. Removing Screws and Nuts**

2. Install the lamp mounting bracket (Figure 11) onto the T-Bar and mast extension with the new screws and nuts provided.

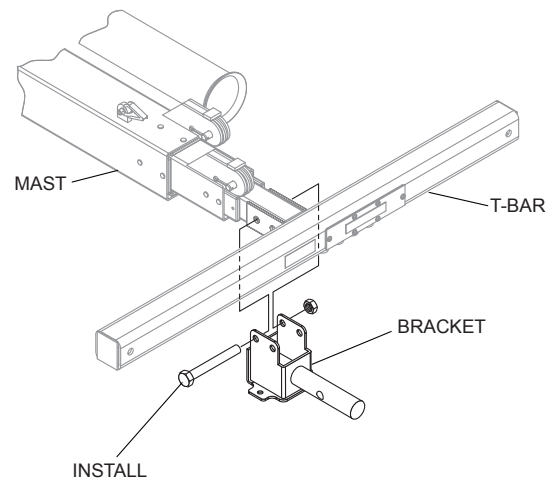

**Figure 11. Installing Bracket**

3. Attach junction box (Figure 12) to lamp mounting bracket with the bolts and washers provided.

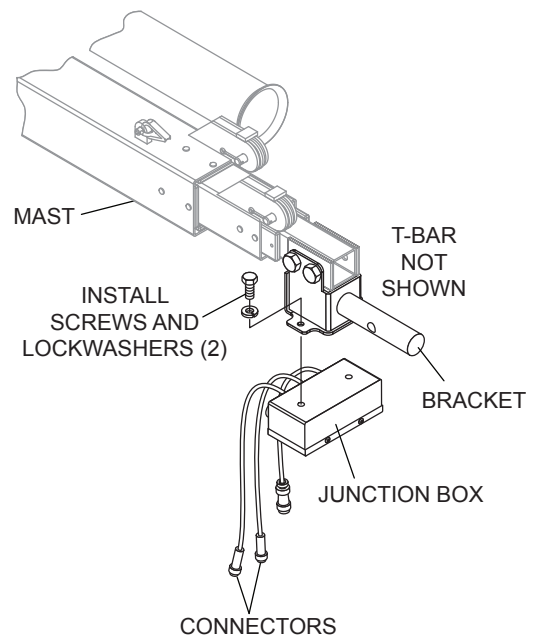

**Figure 12. Junction Box Installation**

## TYPE 1 SETUP (S/N G1900118 AND BELOW)

- Place the GB2000 lamp fixture (Figure 13) onto the lamp mounting bracket. Lock the lamp fixture in place with the cotter pin.

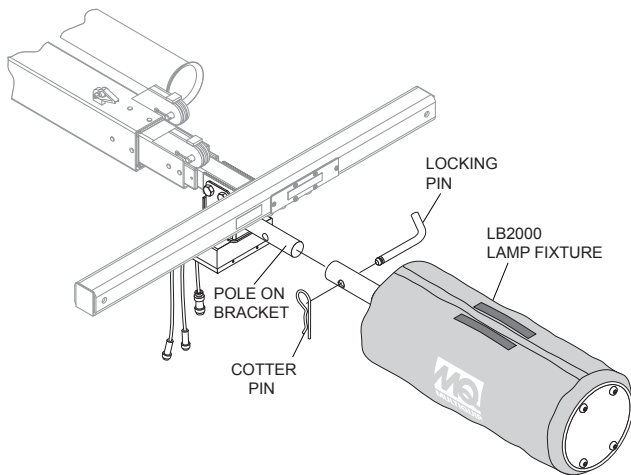

**Figure 13. Installing GB2000 Lamp Fixture**

- Unscrew the protective cap from the lamp power receptacle on the junction box.
- Connect the lamp power cord from the GB2000 lamp fixture to lamp power receptacle on the junction box as shown in Figure 14.

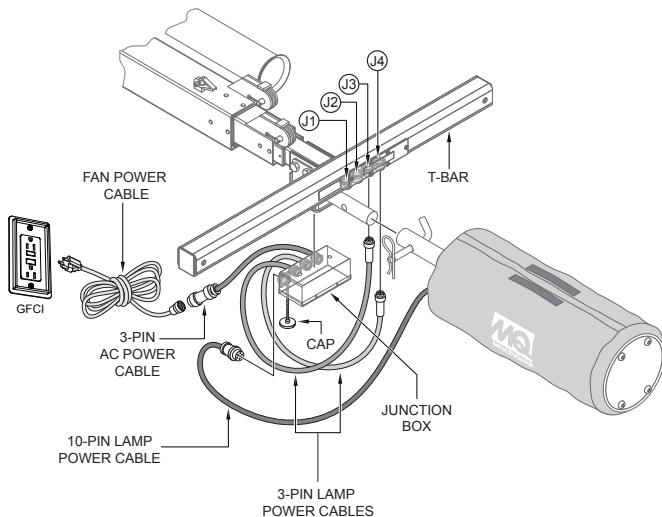

**Figure 14. Junction Box Connections**

### FAN/BALLOON POWER CABLE CONNECTION

- Insert the 38 ft. (11.5 meters), 3-prong AC power plug on the fan power cable as shown in Figure 14 into the GFCI power receptacle on the generator.
- Connect the other end of the fan power cable (quick disconnect end) to the 3-pin AC power cable on the junction box.

### 10-PIN LAMP POWER CABLE CONNECTION

- Unscrew the protective cap from the lamp power receptacle on the junction box.
- Connect the 10-pin lamp power cable from the balloon to the 10-pin lamp power receptacle on the junction box as shown in Figure 14.

### LAMP CABLE CONNECTIONS LT12

- For LT12 series light towers connect the 2 lamp power cables (Figure 14) from the junction box to the J3 and J4 receptacles on the T-Bar as shown in Figure 14.
- If necessary, reinstall bottom lamps onto the T-Bar. At the T-Bar, connect bottom lamps as shown in the lighting option section of this manual.

### LAMP CABLE CONNECTIONS MLT

- For MLT series light towers connect the 2 lamp power cables from the junction box to the J3 and J4 receptacles on the T-Bar as shown in Figure 14.
- If necessary, reinstall bottom lamps onto the T-Bar. At the T-Bar, connect bottom lamps as shown in the lighting option section of this manual.

# TYPE 2 SETUP (S/N G1900119 AND ABOVE)

## PREPARATION

1. Place the light tower in an area free of dirt and debris with enough clearance as not to interfere with any overhead obstructions. Make sure it is on secure level ground with chock blocks underneath each wheel to prevent the light tower from rolling.

**⚠ DANGER**

**ALWAYS** make sure the area above light tower is open and clear of overhead power lines and other obstructions. The tower extends in excess of 30 ft. (9 meters). Contact with overhead power lines or other obstructions could result in equipment damage, serious injury or death!

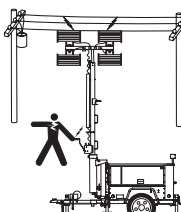

2. If the light tower is in the deployed position, place the tower mast into the cradle support (stowed position). See Figure 15. Make sure cradle lock/release pin has been inserted and the mast is locked.

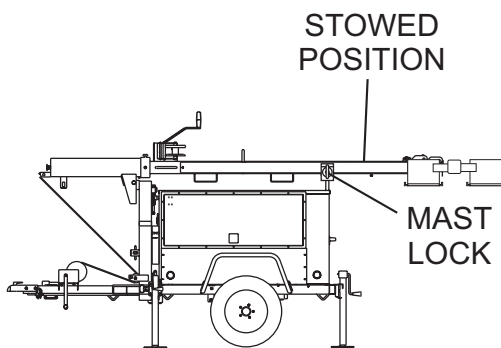

Figure 15. Light Tower in Stowed Position

## NOTICE

The new lamp adapter plate requires no existing lamp removal for installation. All lamps can remain in place during installation of the adapter plate.

## POWER DISCONNECTION

1. For LT12D light towers, disconnect the negative cable (black) from battery. See Figure 6.

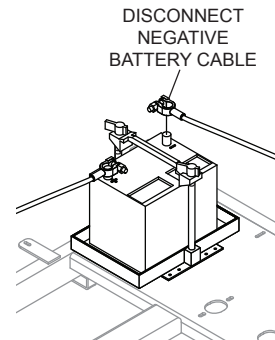

Figure 16. Disconnecting Battery

2. For MLT series light towers disconnect the 4-pin power cable (Figure 17) from the 120 VAC twist-lock receptacle on the front panel of the generator.

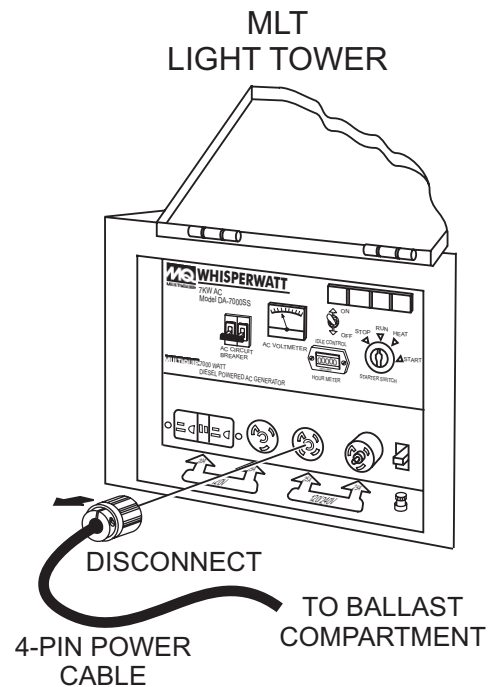

Figure 17. MLT Power Cable Removal

## TYPE 2 SETUP (S/N G1900119 AND ABOVE)

### LAMP ADAPTER PLATE MOUNTING INSTALLATION

1. Remove the adapter plate kit hardware from its container.
2. Before proceeding make sure the light tower mast is in the stow position (down) and the cradle lock/release pin has been inserted and the mast is locked.
3. Attach the lamp adapter plate to the T-Bar as shown in Figure 18. Align adapter plate so that adapter spacer notch fits over screw on T-Bar. Please pay close attention to the orientation of the 2 support brackets.
4. Mount the flat end of both support brackets flush against the T-Bar with the **low** end of each bracket facing inward toward the mast. The **raised** end of each bracket should be facing outward.

#### NOTICE

Please pay close attention to the orientation of the 2 support brackets. Each bracket has a high and low side. the low side of the bracket should be facing inwards towards the mast.

5. Next, insert a bolt (4) and flat washer (4) thru the mounting holes on the the adapter plate as shown in Figure 18. Again, pay close attention on which set of holes to insert the bolt thru. **Bolt number 2** must be oriented so that it passes between receptacles J1 and J2 on the T-Bar.
6. Secure the adapter plate to the T-Bar using the supplied flat washer (4), lock washer (4) and nut (4). Make sure the adapter plate is level (use a bubble level) and both brackets are straight (vertical), not slanted before tightening

# TYPE 2 SETUP (S/N G1900119 AND ABOVE)

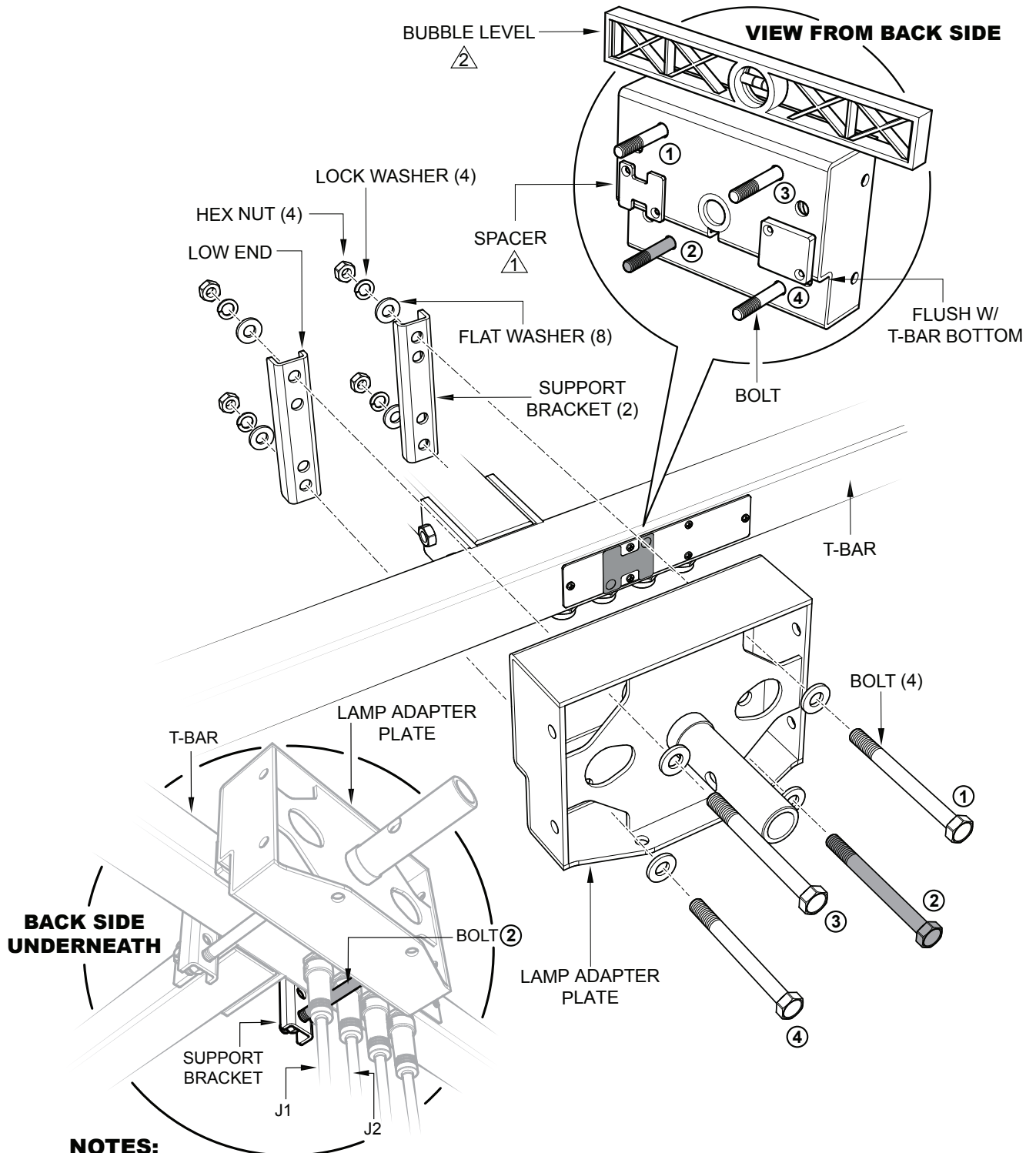

**NOTES:**

- ⚠️ It is important for the adapter SPACER to seat against the T-Bar as shown above.
- ⚠️ For proper alignment of the adapter plate, use of a bubble level is required.

Figure 18. Adapter Plate Mounting Installation

# TYPE 2 SETUP (S/N G1900119 AND ABOVE)

## JUNCTION BOX MOUNTING

1. Secure the junction box (Figure 19) to the adapter plate using the supplied bolts (2), lock washer (2), and flat washer (2). Tighten mounting bolts securely.

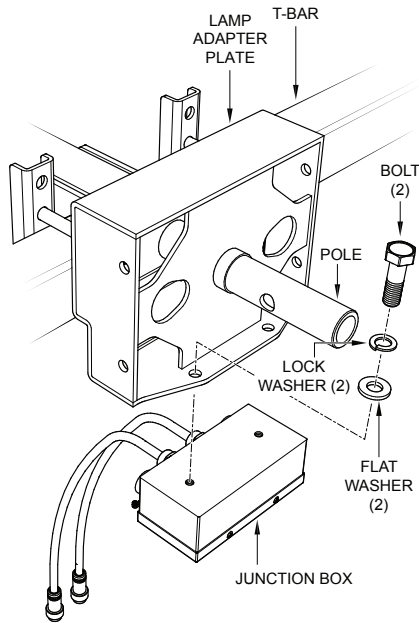

Figure 19. Junction Box Mounting

## LAMP MOUNTING

1. Place the GB2000 lamp fixture onto the lamp adapter plate pole as shown in Figure 20.
2. Insert locking pin into hole opening on pole, then insert cotter pin to lock pin in place.

## FAN POWER CABLE CONNECTION

1. Insert the 38 ft. (11.5 meters), 3-prong AC power plug on the fan power cable as shown in Figure 20 into the GFCI power receptacle on the generator.
2. Connect the other end of the fan power cable (quick disconnect end) to the 3-pin AC power receptacle on the junction box.

### NOTICE

Once the tower is raised and in position, the fan power cable should be secured in such a way as to prevent tripping and entanglement.

## BALLOON POWER CABLE

1. Connect the balloon power cable (Figure 20) to the 10-pin receptacle on the junction box.

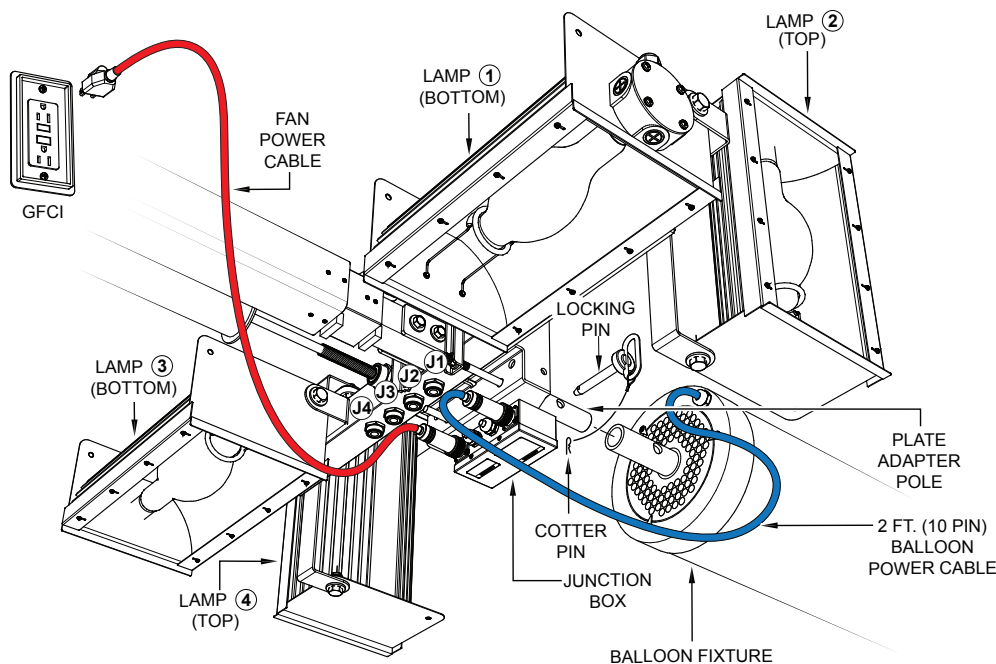

Figure 20. Fan/Balloon Power Cable Connections



## TYPE 2 SETUP (S/N G1900119 AND ABOVE)

Use Figure 21 as a reference when determining orientation of lamps and receptacles on T-Bar. Figure 21 is looking at the light tower from the rear to the front.

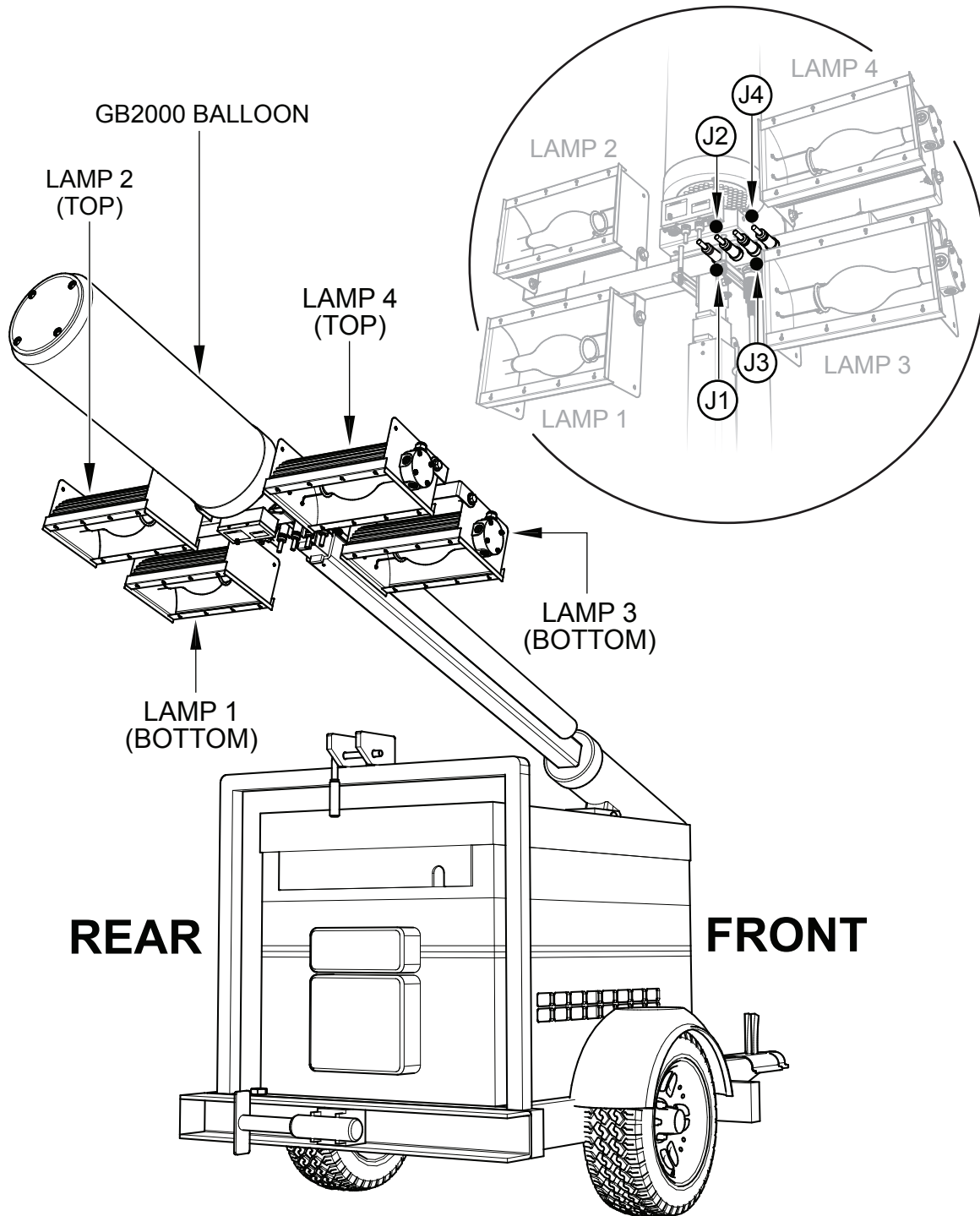
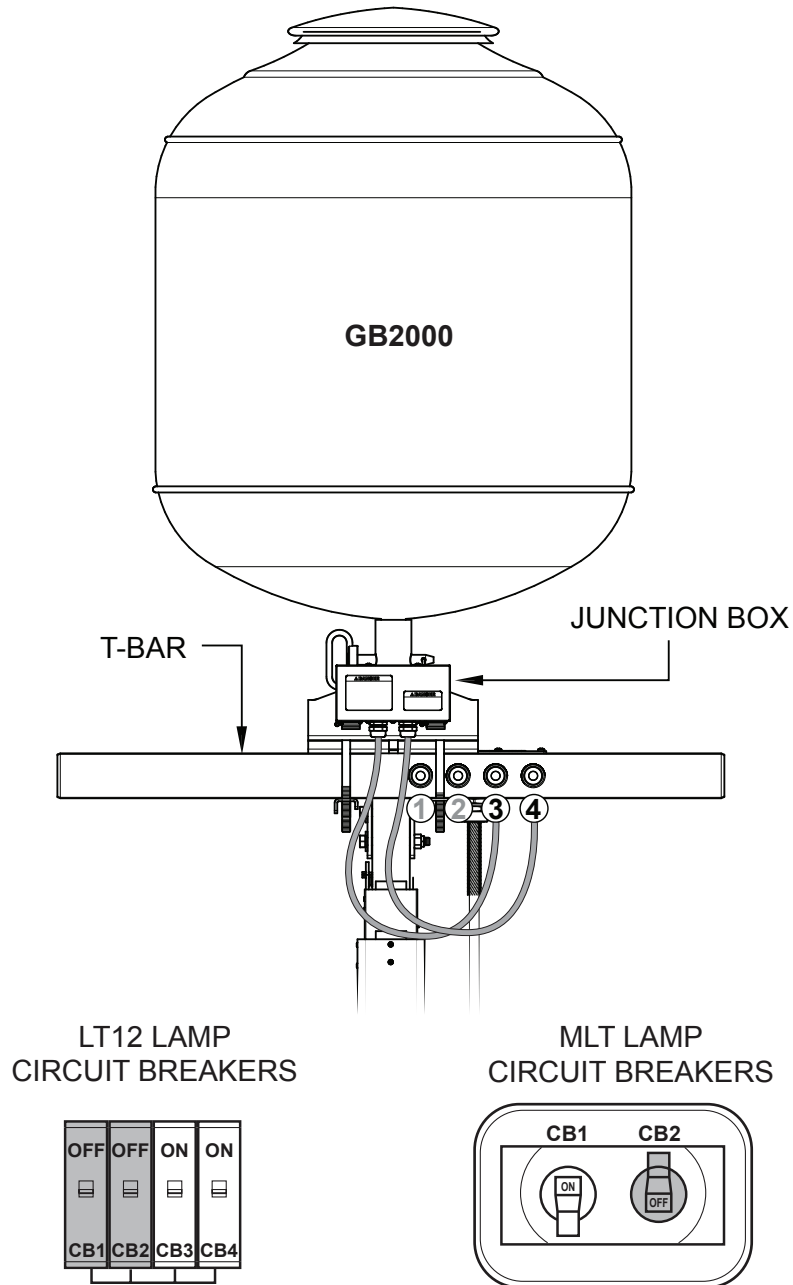

Figure 21. Light Tower Orientation View

# LAMP LIGHTING OPTIONS

## LAMP CABLE CONNECTIONS

On the T-Bar (Figure 22) there are four power receptacles J1, J2, J3 and J4. These receptacles provide AC power to the existing rectangular lamps. When the GB2000 lamp assembly is employed only two of the existing rectangular lamps (bottom lamps recommended) will be available for use. Please reference Figure 22 thru Figure 27 for the various lighting options.



**All Lamps Removed  
GB2000 Operational**

**Figure 22. Option 1 Lighting Configuration**

# LAMP LIGHTING OPTIONS

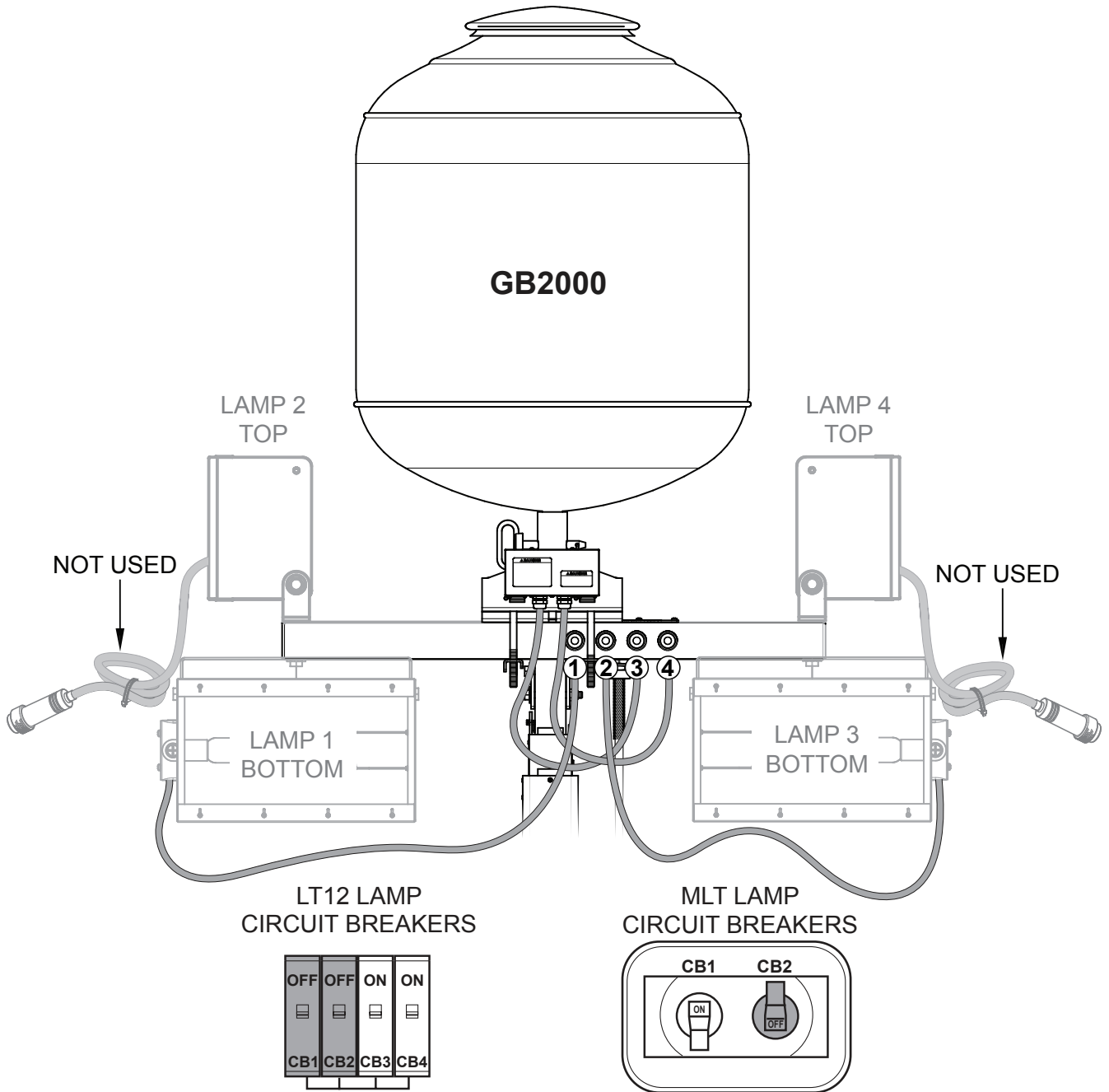

**4 Lamps Installed on T-Bar  
Only GB2000 Operational**

**Figure 23. Option 2 Lighting Configuration**

# LAMP LIGHTING OPTIONS

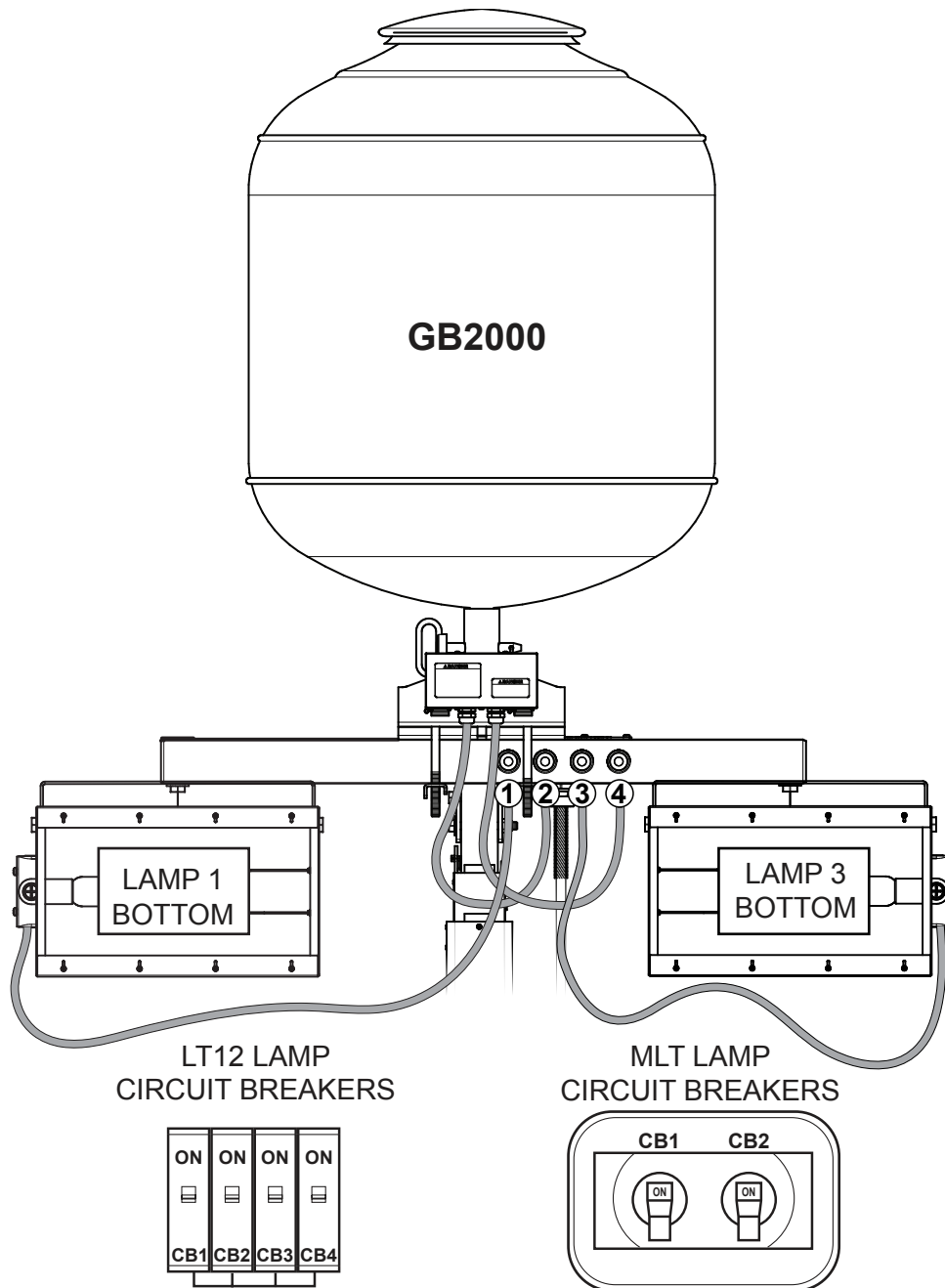

**2 Top Lamps Removed  
GB2000 Operational  
2 Bottom Lamps Operational**

**Figure 24. Option 3 Lighting Configuration**

# LAMP LIGHTING OPTIONS

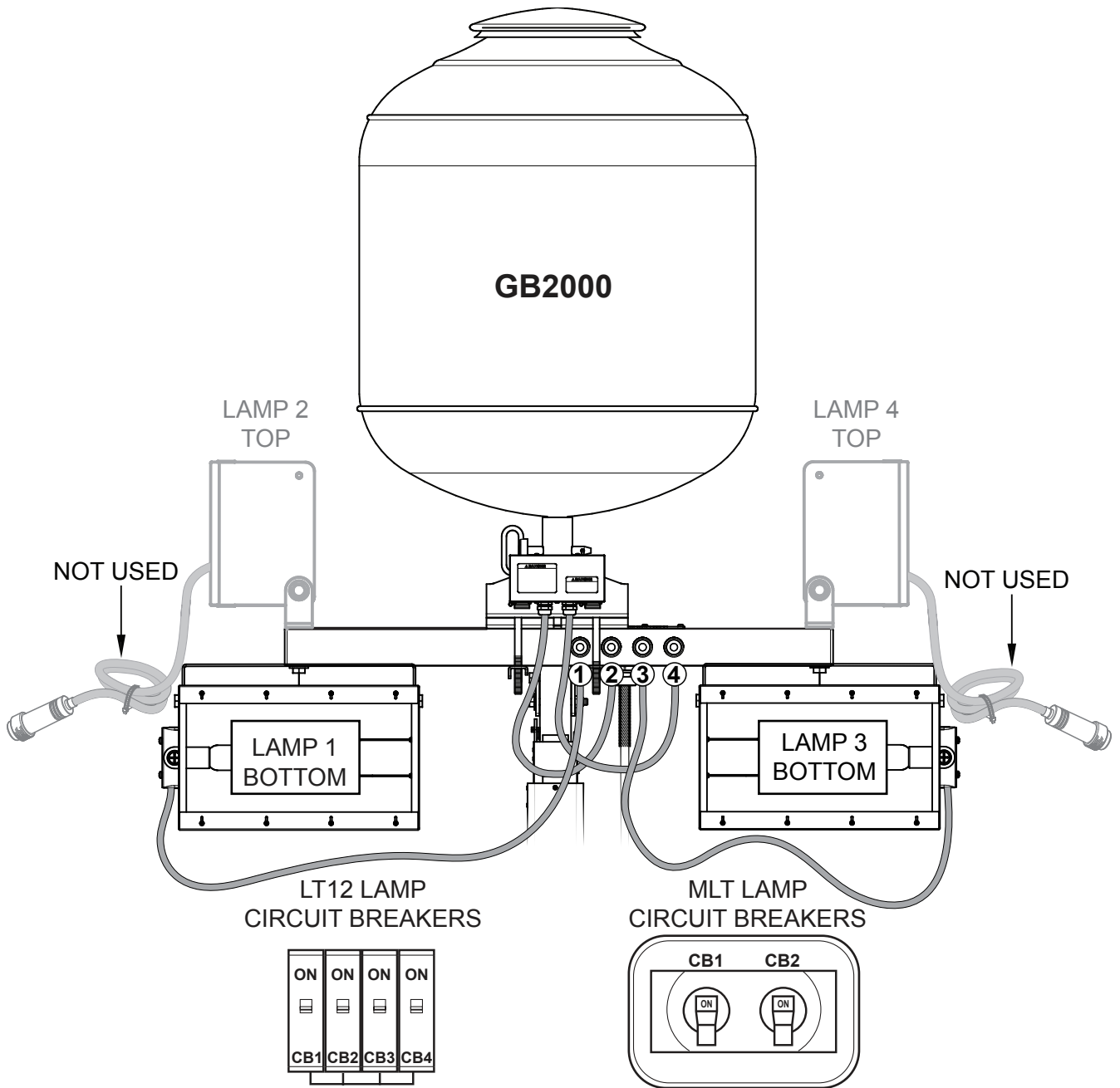

4 Lamps Installed on T-Bar  
GB2000 Operational  
2 Bottom Lamps Operational

Figure 25. Option 4 Lighting Configuration

# LAMP LIGHTING OPTIONS

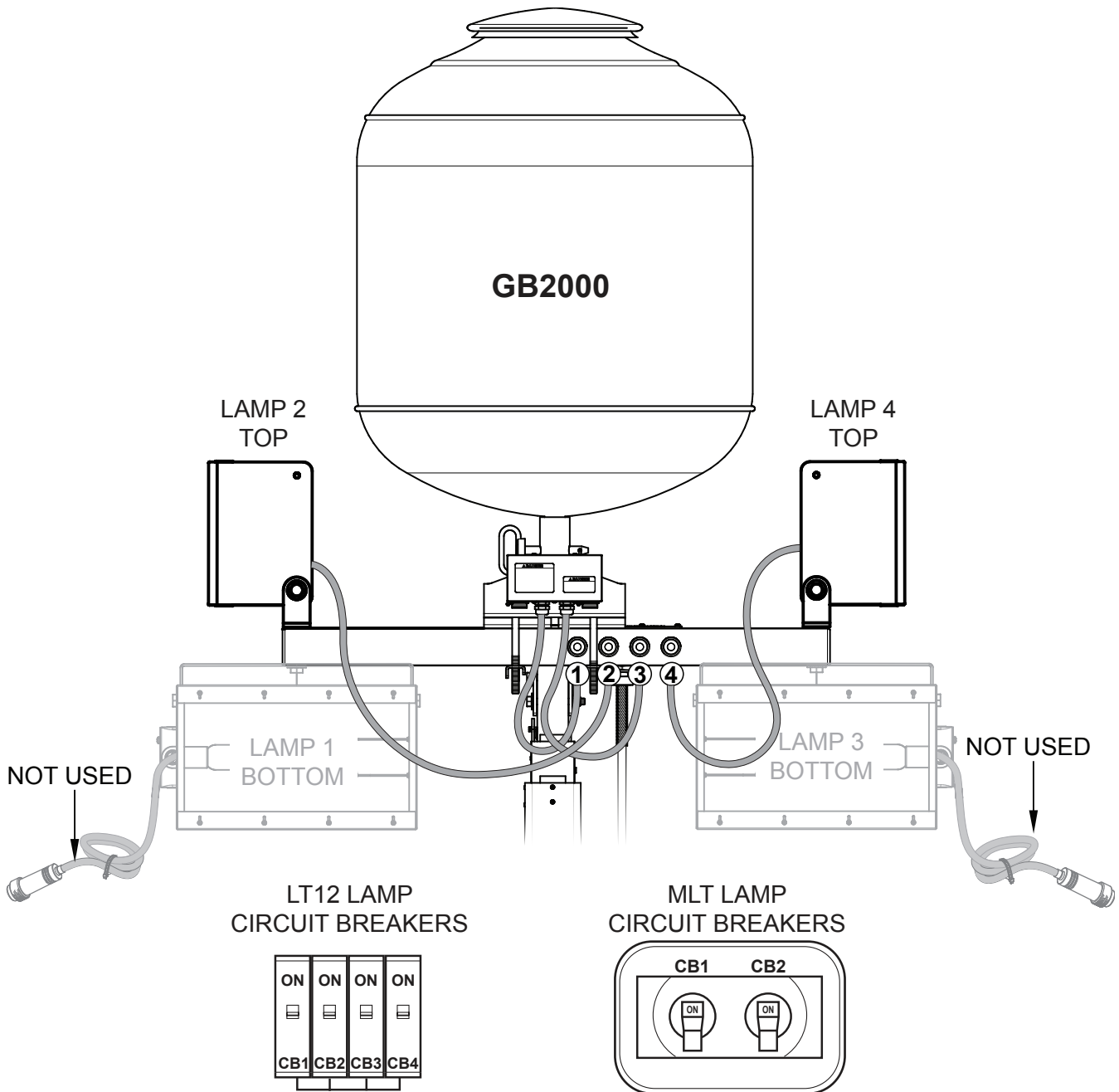

**4 Lamps Installed on T-Bar  
GB2000 Operational  
2 Top Lamps Operational**

**Figure 26. Option 5 Lighting Configuration**

# LAMP LIGHTING OPTIONS

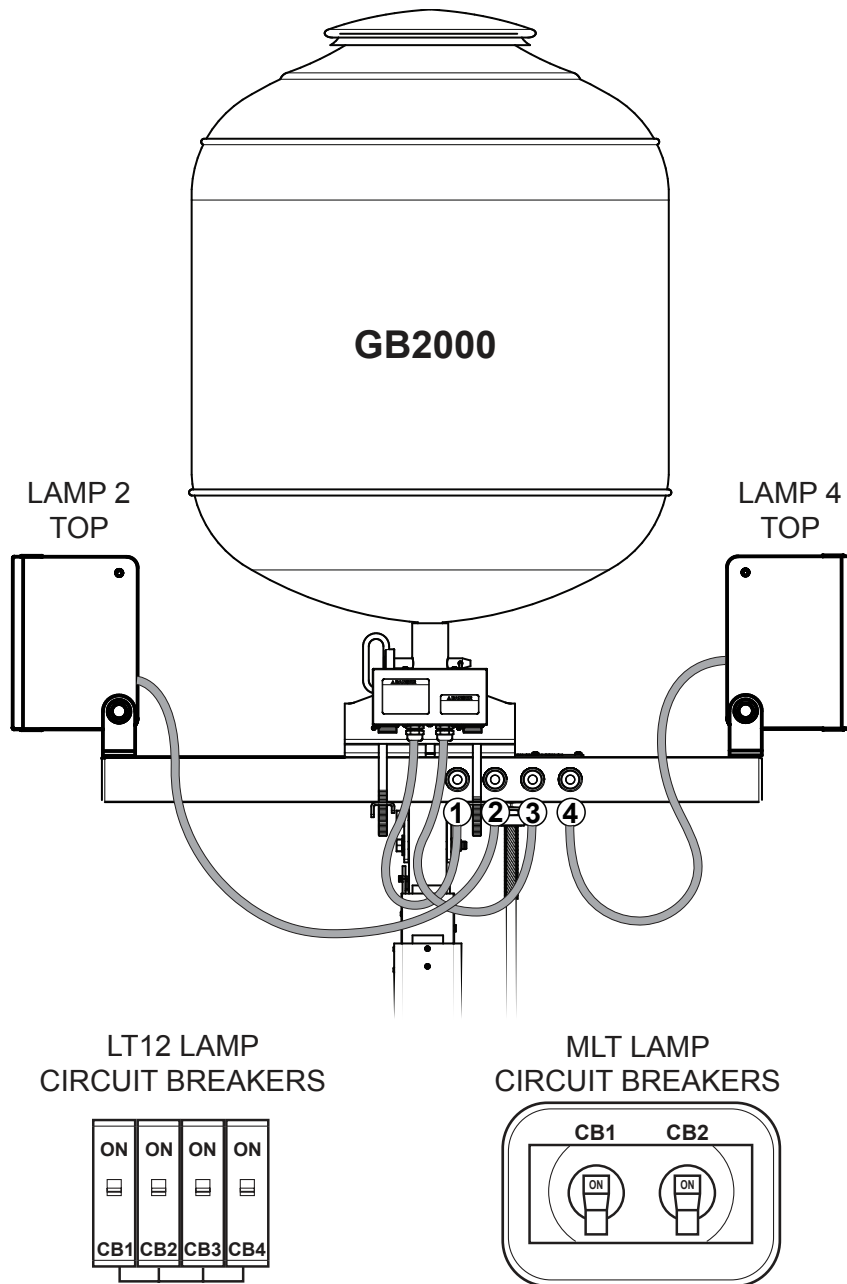

**2 Bottom Lamps Removed  
GB2000 Operational  
2 Top Lamps Operational**

**Figure 27. Option 6 Lighting Configuration**

## REMOVING BALLOON PROTECTIVE COVER

### CAUTION



**DO NOT** use excessive force when zipping or unzipping the balloon. The possibility exists of the zipper tearing, which would make the balloon unusable.

1. Expose the balloon by unsnapping the buttons and unzipping the protective cover as shown in Figure 28.

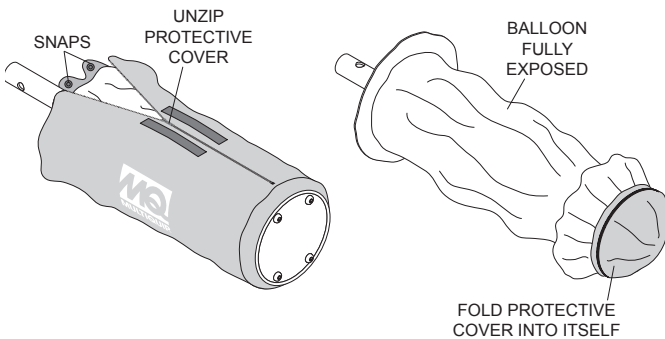

**Figure 28. Removing Protective Cover**

2. Next, fold the protective cover into itself and zip. See Figure 28.

## INFLATING BALLOON AND TURNING ON LAMPS LT12 ONLY

1. On LT12 series light towers, reconnect negative battery cable (black).
2. Slightly raise the light tower mast to allow clearance for the balloon to inflate.
3. Start the light tower engine as referenced in the LT12 light tower operation manual.
4. Once, the engine has started, place the GFCI and main circuit breaker switches (Figure 29) on the LT12 control panel in the ON position. The balloon should begin to inflate.

### NOTICE

Ensure the fan power cable is routed safely as it travels from the junction box, down the mast to the selected GFCI receptacle.

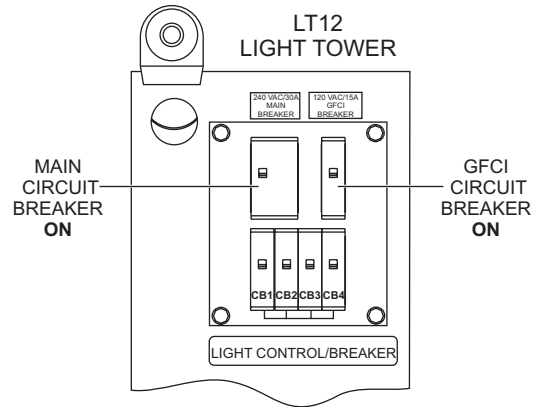

**Figure 29. Main, GFCI Circuit Breakers (ON/LT12)**

5. Next, turn on lamp circuit breakers as referenced in the lamp lighting options section of this manual.
6. Secure any unused lamp cables.
7. Raise the light tower mast (Figure 30) to the desired upright height.

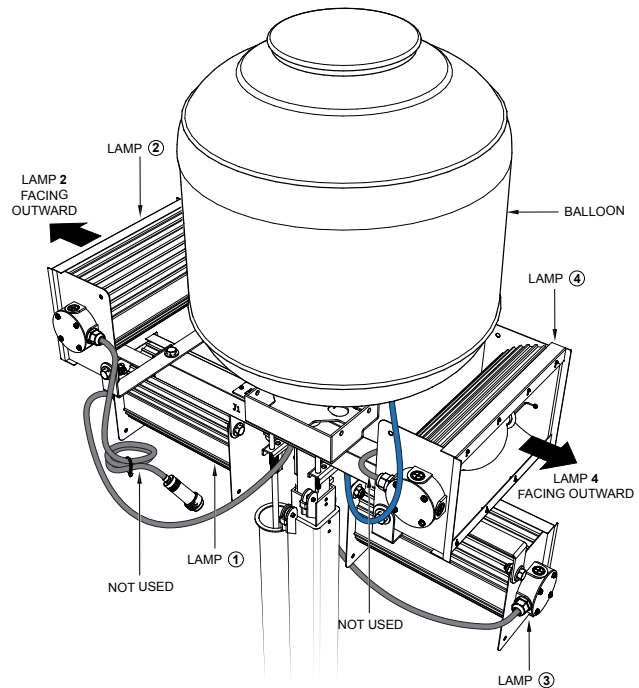

**Figure 30. Balloon Deployed (Typical Application)**



## INFLATING BALLOON AND TURNING ON LAMPS MLT ONLY

1. On MLT series light towers, reconnect the 4-pin power cable (Figure 31) to the 120 VAC twist-lock receptacle on the front panel of the generator.



**Figure 31. MLT Ballast 4-pin Power Cable**

2. Slightly raise the light tower mast to allow clearance for the balloon to inflate.
3. Start the light tower engine as referenced in the MLT operation manual.
4. Once, the engine has started, place the GFCI and main circuit breaker switches (Figure 32) on the MLT front control panel in the **ON** position. The balloon should begin to inflate.

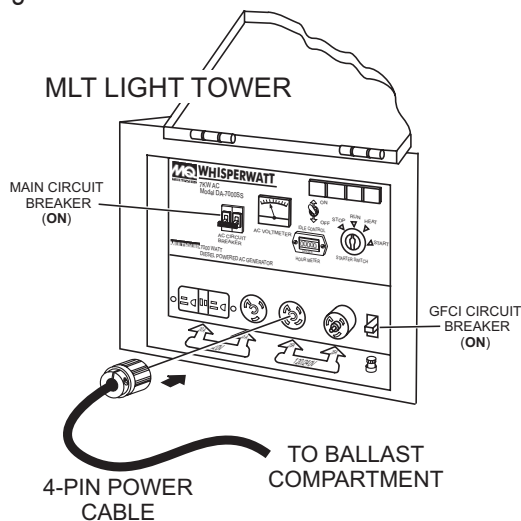

**Figure 32. Main, GFCI Circuit Breakers (ON/MLT)**

5. Next, turn on lamp circuit breakers as referenced in the lamp lighting options section of this manual.
6. Secure any unused lamp cables.
7. Raise the light tower mast (Figure 30) to the desired upright height.

## DEFLATING AND STORING BALLOON

1. Turn lamps **OFF** and allow to cool for at least five minutes.
2. Once the lamps have cooled, place the GFCI and main breaker switches in the **OFF** position.

### NOTICE

**ALWAYS** make sure lamps are turned off and allowed to cool before deflating balloon to avoid any damage to the balloon. **NEVER** transport GB2000 lamp fixture while attached to mast.

3. Unplug power cord from the GFCI receptacle on the generator.
4. When the balloon is completely deflated, unzip the protective cover and fold the balloon inside the cover.
5. Carefully zip up the cover and snap the buttons to fully close the protective cover.
6. Remove all cables from T-Bar, and remove balloon power cable from junction box.
7. Pull cotter pin from locking pin and remove lamp assembly from light tower mast.
8. Store lamp assembly in a safe place where it will not get damaged.

## REPLACING LAMP

### DANGER

Never attempt to replace lamp in a wet place. The possibility exists of electric shock.

### WARNING



Always allow sufficient time for the lamp to cool down before replacing. The possibility exists of severe burns if hot lamp is touched.

### CAUTION

Always shutdown power source and remove balloon assembly from mast when replacing a broken lamp. Utmost care should be taken in handling broken lamp. The possibility exists of serious injury from handling a broken lamp.

1. Unzip the zipper at the bottom of the balloon and roll the balloon up to expose the lamp. See Figure 33.

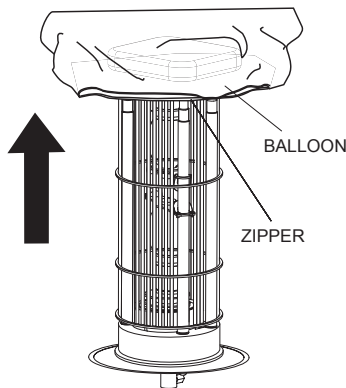

**Figure 33. Exposing Balloon**

2. Release the lamp guard hooks from the poles and remove the two lamp guards. See Figure 34.

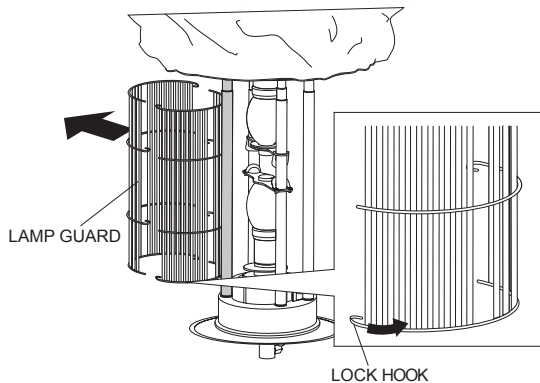

**Figure 34. Removing Lamp Guard**

3. Press the tabs on the lamp holder and push up lamp holder to release it from lamp. Do the same to the lower lamp if necessary. See Figure 35.

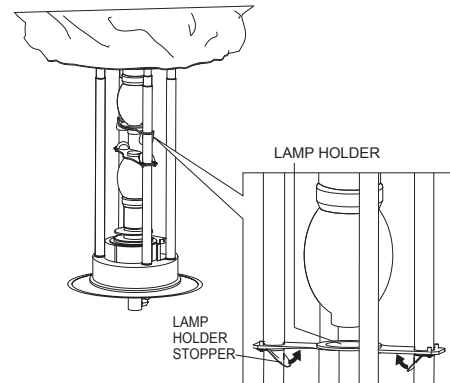

**Figure 35. Lamp Holder**

4. Remove lamp from the lamp socket by turning lamp counterclockwise. See Figure 36.

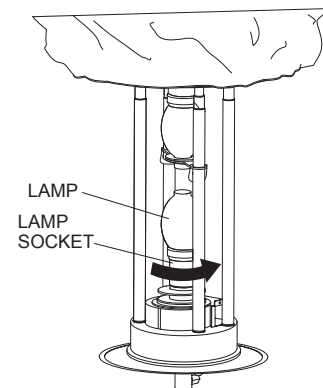

**Figure 36. Removing Lamp**

5. Install new lamp into socket and turn lamp in a clockwise direction until tight. See Figure 37.

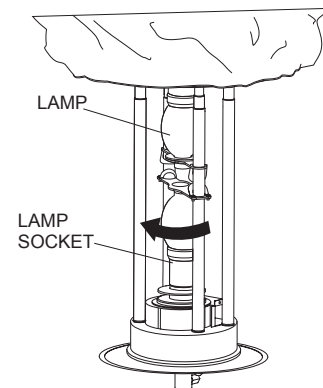

**Figure 37. Installing New Lamp**

## NOTICE

Do not use excessive force when screwing the lamp to prevent lamp from breaking.

6. Secure lamp holder on top of the lamp.
7. Reinstall lamp guard.
8. Pull down balloon and zip the bottom zipper to cover lamp.

## REPLACING BALLOON

1. Unzip the top and bottom of the balloon. See Figure 38.

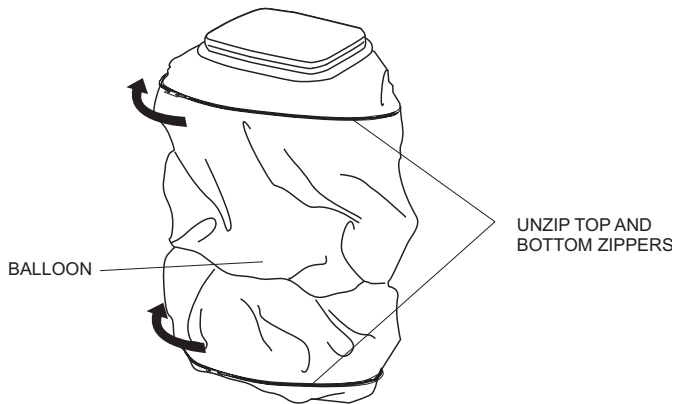

**Figure 38. Unzipping Balloon**

2. Slide out the old or worn balloon over the top of the lamp guard assembly. See Figure 39.



**Figure 39. Removing Old Balloon**

3. Slide in the new replacement balloon over the top of the lamp guard assembly. See Figure 40.

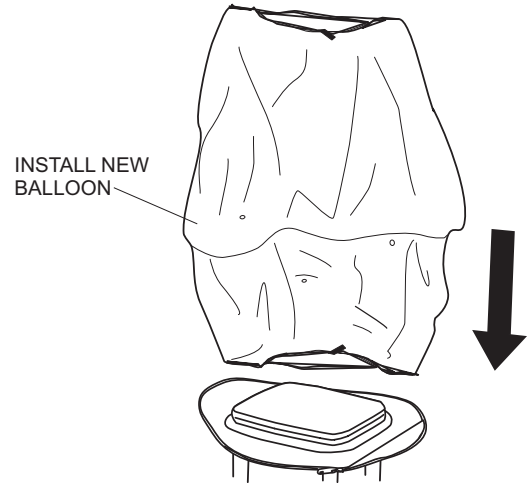

**Figure 40. Replacing Balloon**

4. Zip up the top and bottom of the new balloon. See Figure 41.

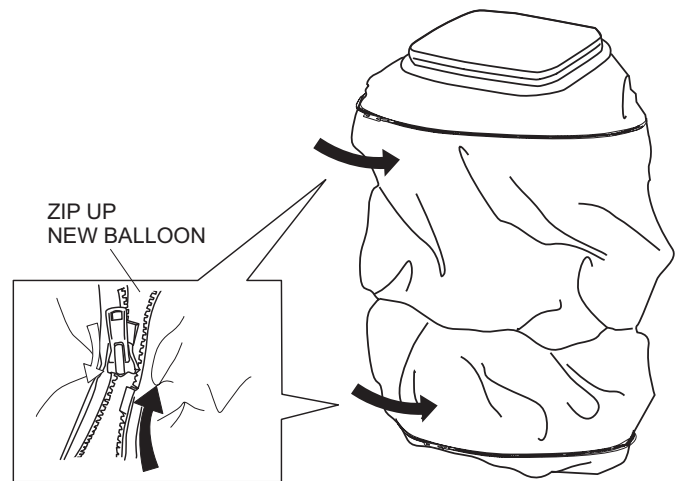
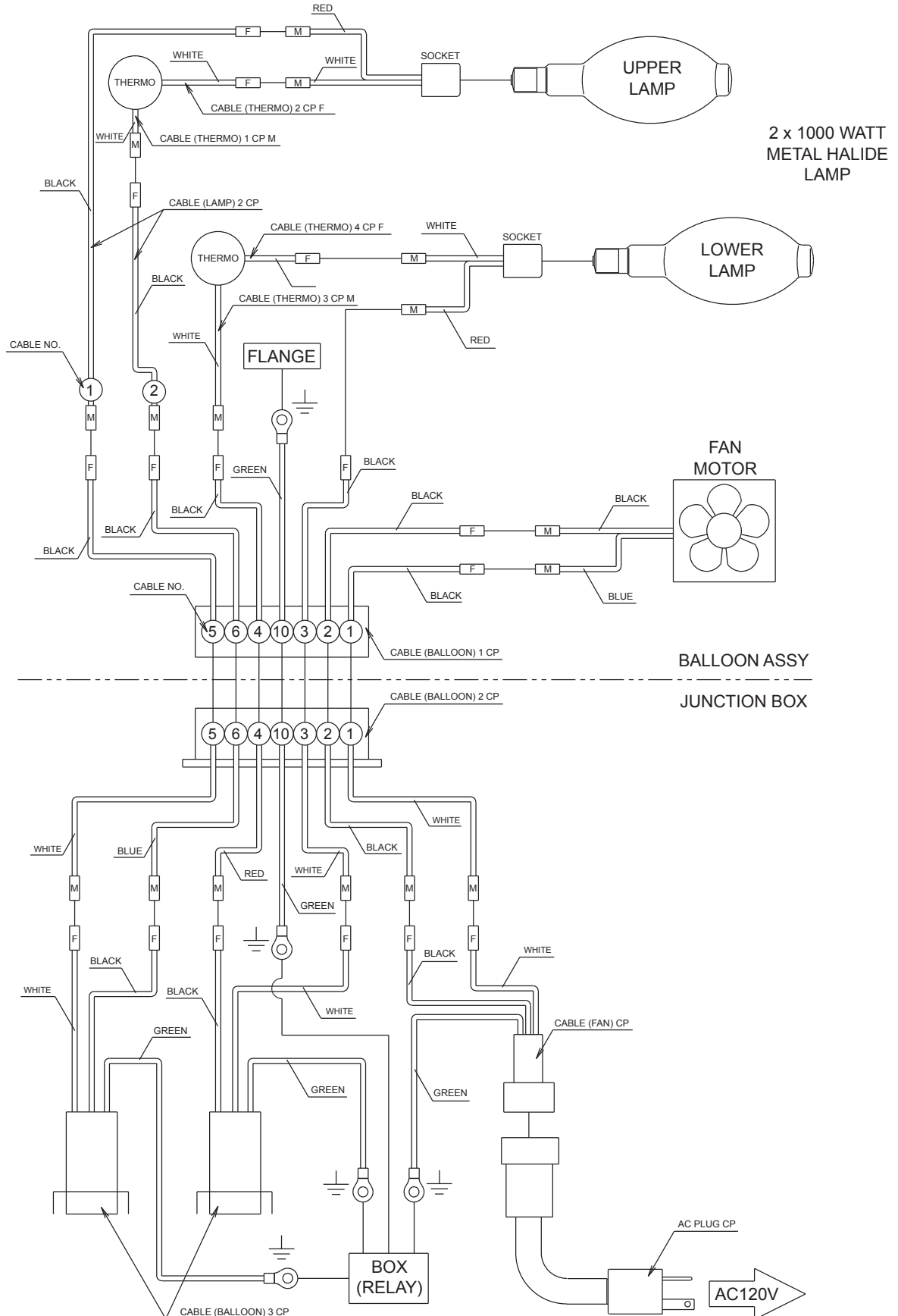

**Figure 41. Zipping Up New Balloon**

**Table 4. Troubleshooting**

<b>SYMPTOM</b>	<b>POSSIBLE PROBLEM</b>	<b>SOLUTION</b>
Lamp does not light.	Is plug disconnected?	Plug in correctly.
	Is generator power switched off?	Turn on switch.
	Is lamp loose?	Screw lamp securely into socket.
	Is power connector disconnected or loose?	Connect disconnected connector.
	Is model of lamp incompatible?	Use genuine MQ lamp.
Lamp only lights for a short time.	Is ambient temperature too high - more than 104° F (40° C)?	Move lamp where there is proper ventilation.
Balloon does not inflate.	Is fan motor not working properly?	Check and repair fan motor.
	Is balloon cloth defective?	Repair or replace balloon cloth.

# WIRING DIAGRAM



# EXPLANATION OF CODE IN REMARKS COLUMN

The following section explains the different symbols and remarks used in the Parts section of this manual. Use the help numbers found on the back page of the manual if there are any questions.

**NOTICE**

The contents and part numbers listed in the parts section are subject to change **without notice**. Multiquip does not guarantee the availability of the parts listed.

## SAMPLE PARTS LIST

NO.	PART NO.	PART NAME	QTY.	REMARKS
1	12345	BOLT .....	1	INCLUDES ITEMS W/%
2%		WASHER, 1/4 IN. ....		NOT SOLD SEPARATELY
2%	12347	WASHER, 3/8 IN. ...	1	MQ-45T ONLY
3	12348	HOSE .....		A/R ...MAKE LOCALLY
4	12349	BEARING .....	1	S/N 2345B AND ABOVE

## NO. Column

**Unique Symbols** — All items with same unique symbol (@, #, +, %, or >) in the number column belong to the same assembly or kit, which is indicated by a note in the “Remarks” column.

**Duplicate Item Numbers** — Duplicate numbers indicate multiple part numbers, which are in effect for the same general item, such as different size saw blade guards in use or a part that has been updated on newer versions of the same machine.

**NOTICE**

When ordering a part that has more than one item number listed, check the remarks column for help in determining the proper part to order.

## PART NO. Column

**Numbers Used** — Part numbers can be indicated by a number, a blank entry, or TBD.

TBD (To Be Determined) is generally used to show a part that has not been assigned a formal part number at the time of publication.

A blank entry generally indicates that the item is not sold separately or is not sold by Multiquip. Other entries will be clarified in the “Remarks” Column.

## QTY. Column

**Numbers Used** — Item quantity can be indicated by a number, a blank entry, or A/R.

A/R (As Required) is generally used for hoses or other parts that are sold in bulk and cut to length.

A blank entry generally indicates that the item is not sold separately. Other entries will be clarified in the “Remarks” Column.

## REMARKS Column

Some of the most common notes found in the “Remarks” Column are listed below. Other additional notes needed to describe the item can also be shown.

**Assembly/Kit** — All items on the parts list with the same unique symbol will be included when this item is purchased.

Indicated by:

“INCLUDES ITEMS W/(unique symbol)”

**Serial Number Break** — Used to list an effective serial number range where a particular part is used.

Indicated by:

“S/N XXXXX AND BELOW”

“S/N XXXX AND ABOVE”

“S/N XXXX TO S/N XXX”

**Specific Model Number Use** — Indicates that the part is used only with the specific model number or model number variant listed. It can also be used to show a part is NOT used on a specific model or model number variant.

Indicated by:

“XXXXX ONLY”

“NOT USED ON XXXX”

**“Make/Obtain Locally”** — Indicates that the part can be purchased at any hardware shop or made out of available items. Examples include battery cables, shims, and certain washers and nuts.

**“Not Sold Separately”** — Indicates that an item cannot be purchased as a separate item and is either part of an assembly/kit that can be purchased, or is not available for sale through Multiquip.

## SUGGESTED SPARE PARTS

---

### GB2000 BALLOON LIGHT

1 to 3 units

Qty.	P/N	Description
2.....	E000080700 .....	LAMP
2.....	A100085100 .....	BALLOON CLOTH CP
3.....	A400038300 .....	FILTER

#### **NOTICE**

Part numbers on this Suggested Spare Parts list may supersede/replace the part numbers shown in the following parts lists.

# ELECTRICAL ASSY.

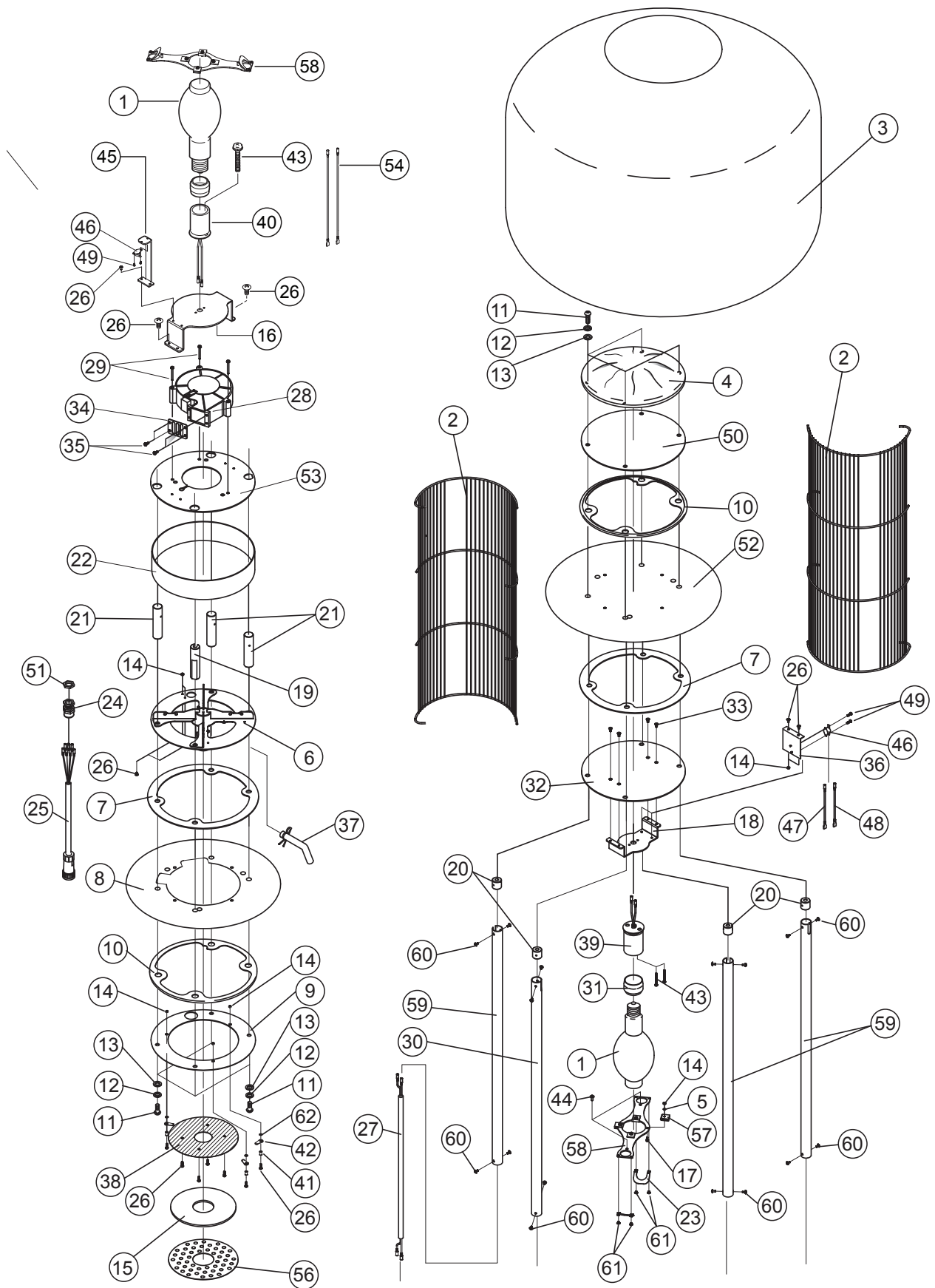



## ELECTRICAL ASSY.

<u>NO.</u>	<u>PART NO.</u>	<u>PART NAME</u>	<u>QTY.</u>	<u>REMARKS</u>
1	E000080700	LAMP	2	
2	A100079700	LAMP GUARD	2	
3	A100085100	BALLOON	1	
4	A100079600	BALLOON COVER CP	1	
5	GB0043104000	WASHER (M4)	8	
6	A200075502	FLANGE	1	
7	2204500131	SEAL (NORMAL)	2	
8	1800001100	SHEET (BOTTOM)	1	
9	A200076101	PLATE (BOTTOM)	1	
10	2204500230	SEAL (PACKING)	2	
11	0014710035	BUTTON BOLT (M10x35)	8	
12	0043210000	SPRING WASHER (M10)	8	
13	0043110000	WASHER (M10)	8	
14	0033104000	NUT(M4)	15	
15	A400038301	FILTER (200)	1	
16	A200075301	PLATE (LAMP) 2	1	
17	0023304012	SCREW & WASHER (M4x12)	8	
18	A300211700	PLATE (LAMP) 3.....	1.....	S/N G11900118 & BELOW
18	A300211701	PLATE (LAMP) 3.....	1.....	S/N G11900119 & ABOVE
19	A400240602	POLE JOINT 1	1	
20	A400240701	POLE JOINT 2	4	
21	A400243501	POLE JOINT 3	3	
22	A200075900	VESSEL	1	
23	A400240801	STOPPER	4	
24	E000098700	CABLE CLAMP	1	
25	A300215000	CABLE (BALLOON) 1 CP.....	1.....	INCLUDES TERMINAL
26	0024304008	SCREW TRUSS (M4x8)	17	
27	A300215100	CABLE (LAMP) 2 CP.....	1.....	INCLUDES TERMINAL
28	A300232800	FAN MOTOR ASSY 120V 60Hz.....	1.....	INCLUDES TERMINAL
29	0023305060	SCREW AND WASHER (M5x60)	3	
30	A300211400	MAIN POLE	1	
31	E000038200	CAP (RUBBER)	2	
32	A200076000	PLATE (LAMP) 1	1	
33	0023204010	COUNTERSUNK SCREW (M4x10)	4	
34	A400037400	GUARD (FAN)	1	
35	0023105008	SCREW (M5x8)	4	
36	A400248800	BRACKET (THERMO) CP	1	
37	E000099000	PIN	1	
38	A300211500	PLATE (GUARD)	1	
39	E000009601	SOCKET ASSY	1	
40	A300167500	SOCKET ASSY	1	
41	E000010301	SPACER (M4x4)	3	
42	A400030700	STOPPER (FILTER)	3	
43	0025304025	SCREW & WASHER (M4x25)	4	
44	0023405012	SCREW TRUSS (M5x12)	4	
45	A400236102	BRACKET (THERMO)	1	

# ELECTRICAL ASSY. (CONTINUED)

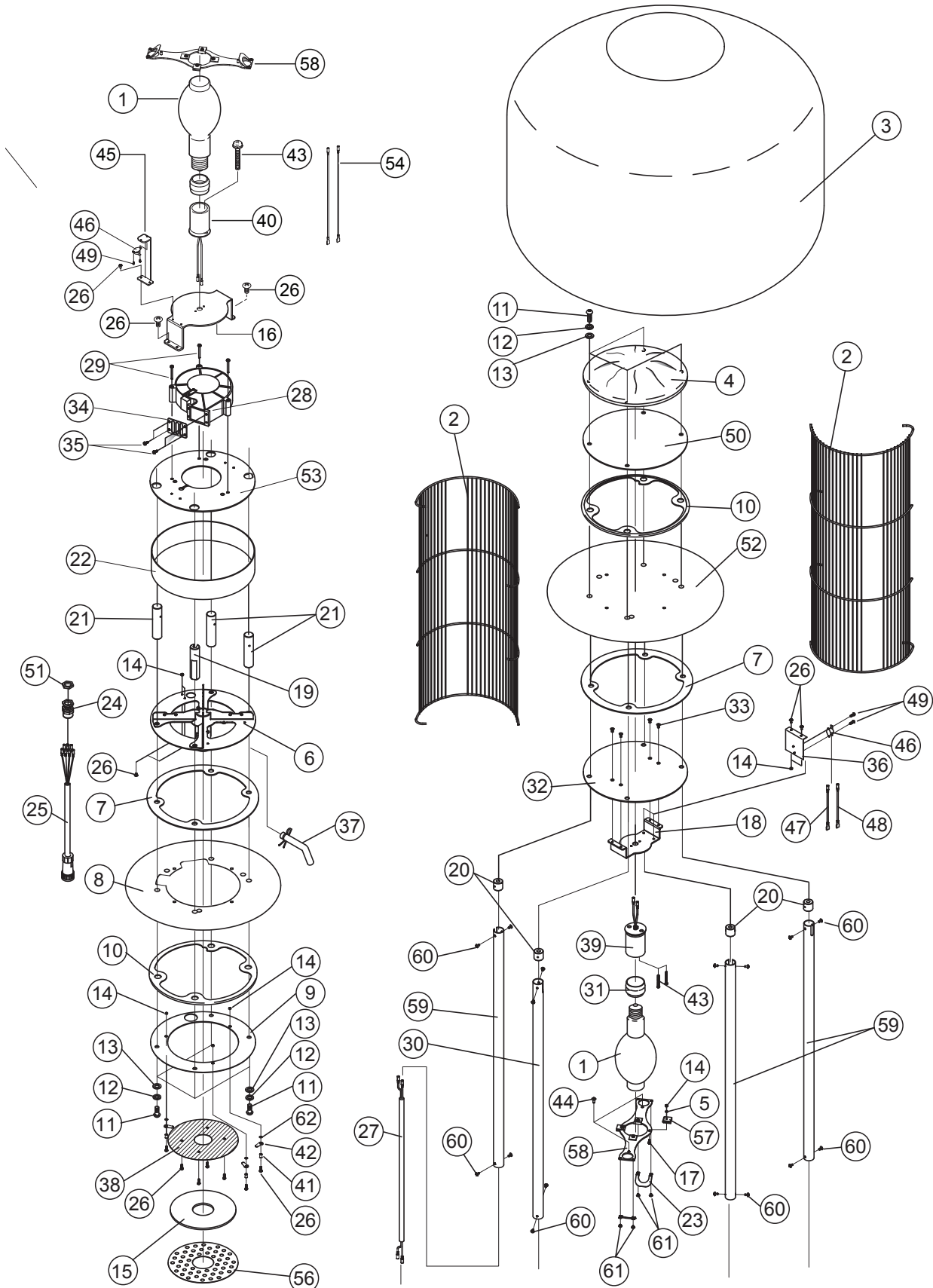

## ELECTRICAL ASSY. (CONTINUED)

<u>NO.</u>	<u>PART NO.</u>	<u>PART NAME</u>	<u>QTY.</u>	<u>REMARKS</u>
46	1411200110	THERMOSTAT	2	
47	A400252301	CABLE (THERMO) 1 CP M .....	1	INCLUDES TERMINAL
48	A400252401	CABLE (THERMO) 2 CP F .....	1	INCLUDES TERMINAL
49	0023103006	SCREW (M3x6)	4	
50	2204220130	PLATE (CAP)	1	
51	E000103600	NUT SMM25	1	
52	1800001000	SHEET (TOP)	1	
53	A200075601	PLATE (FAN)	1	
54	A400244701	CABLE (THERMO) 3 CP M .....	1	INCLUDES TERMINAL
55	A400244801	CABLE (THERMO) 4 CP F .....	1	INCLUDES TERMINAL
56	A200018000	PLATE (AIR)	1	
57	A400199500	PACKING (LAMP)	8	
58	A300211600	LAMP HOLDER	2	
59	A300221900	MAIN POLE 2 .....	3	S/N G11900118 & BELOW
59	A300221901	MAIN POLE 2 .....	3	S/N G11900119 & ABOVE
60	0023405010	TRUSS SCREW M5x10	16	
61	0023404006	SCREW TRUSS (M4x6)	8	
62	E000009701	WAVE WASHER	3	

# BRACKET AND J-BOX ASSY. (S/N G1900118 AND BELOW)

## TYPE 1 ADAPTER

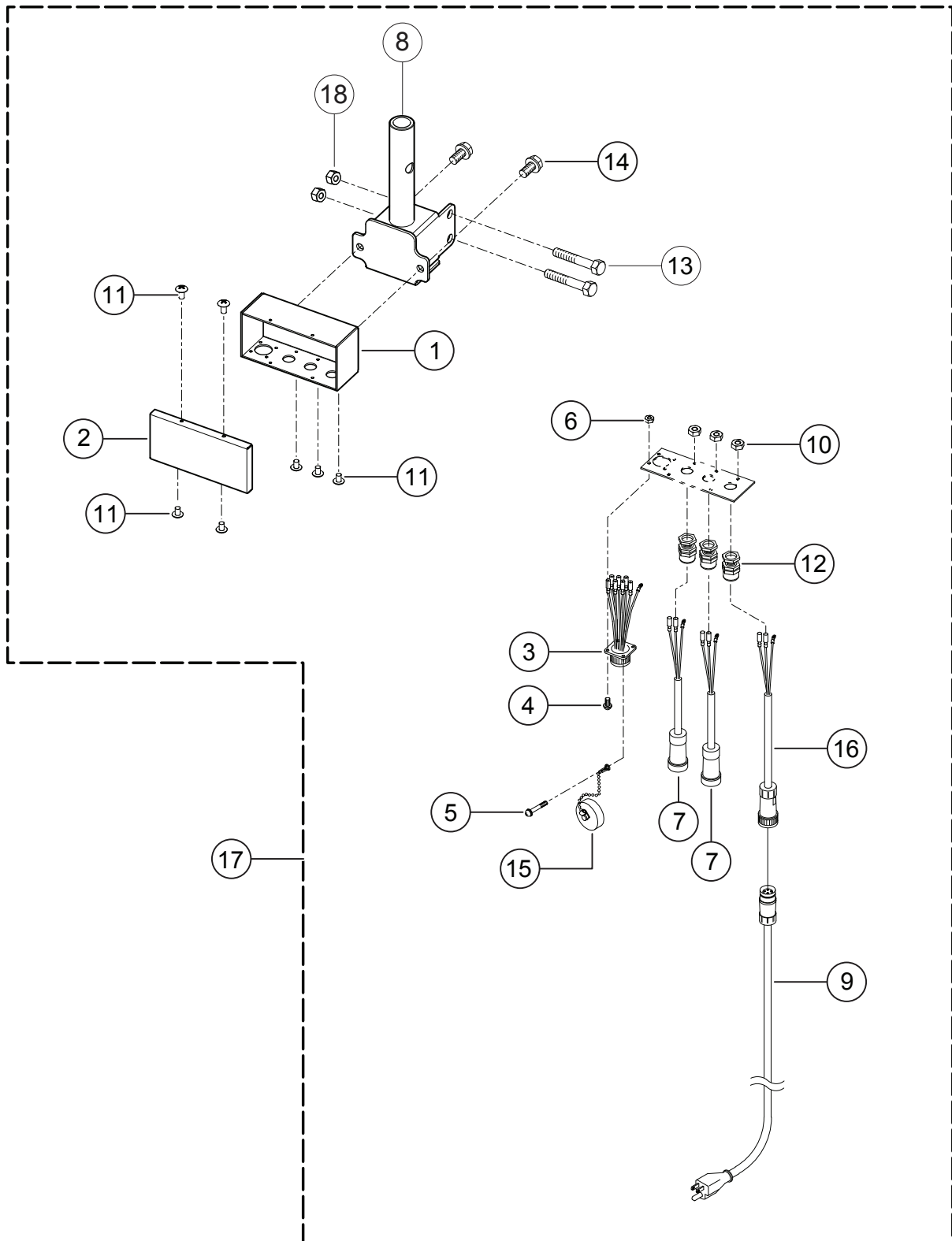

## BRACKET AND J-BOX ASSY. (S/N G1900118 AND BELOW)

<u>NO.</u>	<u>PART NO.</u>	<u>PART NAME</u>	<u>QTY.</u>	<u>REMARKS</u>
1#	A200076200	JUNCTION BOX (RELAY)	1	
2#	A400241000	COVER (RELAY)	1	
3#	A300215200	CABLE (BALLOON) 2 CP.....	1.....	INCLUDES TERMINAL
4#	0023303008	SCREW AND WASHER (M3x8)	3	
5#	0023303012	SCREW AND WASHER (M3x12)	1	
6#	0033103000	NUT (M3)	1	
7#	A300215300	CABLE (LAMP) 3 CP.....	2.....	INCLUDES TERMINAL
8#	A200076300	ADAPTER CP	1	
9#	A300215500	AC PLUG CP.....	1.....	INCLUDES TERMINAL
10#	0033104000	NUT (M4)	3	
11#	0024304008	SCREW TRUSS (M4x8)	7	
12#	E000072600	CABLE CLAMP	3	
13#	E000099100	BOLT 1/213x3 1/2	2	
14#	0013510025	BOLT AND WASHER (M10x25)	2	
15#	E000099200	CAP	1	
16#	A300215400	CABLE (FAN) CP.....	1.....	INCLUDES TERMINAL
17	A000033600	BOX ASSY.....	1.....	INCLUDES ITEMS W/ #
18	10176	NUT, NYLOC 1/2-13	2	

# BRACKET AND J-BOX ASSY. (S/N G1900119 AND ABOVE)

## TYPE 2 UNIVERSAL ADAPTER

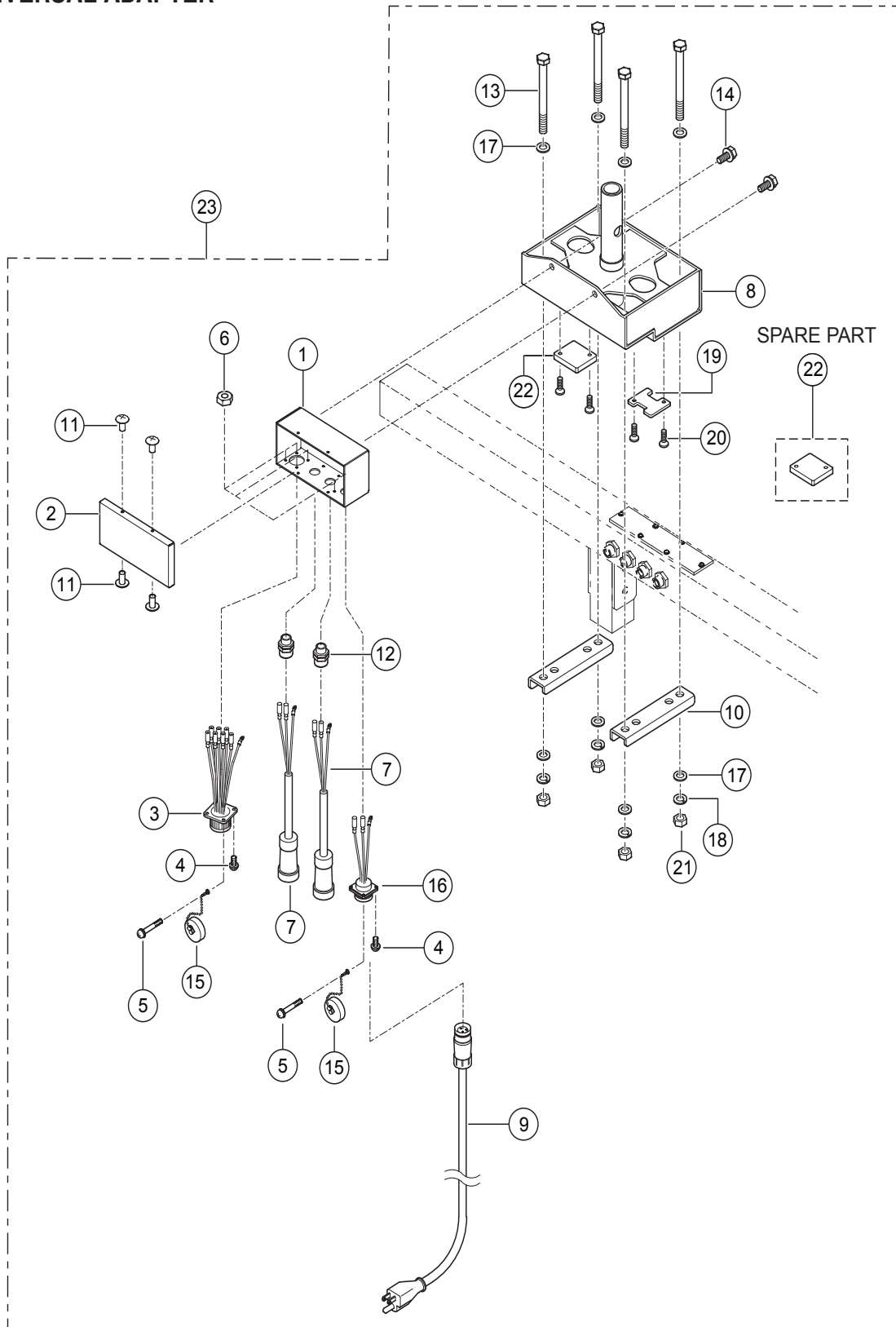

## BRACKET AND J-BOX ASSY. (S/N G1900119 AND ABOVE)

<u>NO.</u>	<u>PART NO.</u>	<u>PART NAME</u>	<u>QTY.</u>	<u>REMARKS</u>
1#	A200084201	JUNCTION BOX (RELAY)	1	
2#	A400241000	COVER (RELAY)	1	
3#	A300215200	CABLE (BALLOON) 2 CP W/TERMINALS	1	
4#	0023303008	SCREW & WASHER M3 X 8	6	
5#	0023303012	SCREW & WASHER M3 X 12	2	
6#	0033103000	NUT M3	8	
7#	A300215300	CABLE (LAMP) 3 CP W/TERMINALS	2	
8#	A100088602	ADAPTER, BRACKET	1	
9#	A300255600	AC PLUG CP W/TERMINALS	1	
10#	A400288000	RETAINER	2	
11#	0024304008	SCREW TRUSS M4 X 8	6	
12#	E000072600	CABLE CLAMP	2	
13#	0013112130	BOLT M122 X 130	4	
14#	0013510025	BOLT & WASHER M10 X 25	2	
15#	E000099200	CAP	2	
16#	A300255700	CABLE (FAN) CP W/TERMINALS	1	
17#	0043112000	WASHER M12	8	
18#	0043212000	SPRING WASHER M12	4	
19#	A400287902	SPACER 1	1	
20#	0023205015	SCREW M5 X 15	4	
21#	0033112000	NUT M12	4	
22#	A400287801	SPACER 2.....	2.....	SPARE SPACER
23	A000039000	BRACKET ASSY., COMPLETE TYPE 2.....	1.....	INCLUDES ITEMS W/#

# OPERATION AND PARTS MANUAL

## HERE'S HOW TO GET HELP

PLEASE HAVE THE MODEL AND SERIAL  
NUMBER ON-HAND WHEN CALLING

### UNITED STATES

#### *Multiquip Inc.*

(310) 537- 3700  
6141 Katella Avenue Suite 200  
Cypress, CA 90630  
E-MAIL: [mq@multiquip.com](mailto:mq@multiquip.com)  
WEBSITE: [www.multiquip.com](http://www.multiquip.com)

---

### CANADA

#### *Multiquip*

(450) 625-2244  
4110 Industriel Boul.  
Laval, Quebec, Canada H7L 6V3  
E-MAIL: [infocanada@multiquip.com](mailto:infocanada@multiquip.com)

### UNITED KINGDOM

#### *Multiquip (UK) Limited Head Office*

0161 339 2223  
Unit 2, Northpoint Industrial Estate,  
Globe Lane,  
Dukinfield, Cheshire SK16 4UJ  
E-MAIL: [sales@multiquip.co.uk](mailto:sales@multiquip.co.uk)

© COPYRIGHT 2019, MULTIQUIP INC.

Multiquip Inc, the MQ logo are registered trademarks of Multiquip Inc. and may not be used, reproduced, or altered without written permission. All other trademarks are the property of their respective owners and used with permission.

This manual MUST accompany the equipment at all times. This manual is considered a permanent part of the equipment and should remain with the unit if resold.

The information and specifications included in this publication were in effect at the time of approval for printing. Illustrations, descriptions, references and technical data contained in this manual are for guidance only and may not be considered as binding. Multiquip Inc. reserves the right to discontinue or change specifications, design or the information published in this publication at any time without notice and without incurring any obligations.

