

OPERATION MANUAL



MODEL HHNG5 RIDE-ON TROWEL (VANGUARD 540000 GASOLINE ENGINE)

Revision #5 (03/25/26)

To find the latest revision of this publication or associated parts manual, visit our website at:
www.multiquip.com



THIS MANUAL MUST ACCOMPANY THE EQUIPMENT AT ALL TIMES.

PN: 30039

PROPOSITION 65 WARNING



SILICOSIS/RESPIRATORY WARNINGS

! WARNING



SILICOSIS WARNING

Grinding/cutting/drilling of masonry, concrete, metal and other materials with silica in their composition may give off dust or mists containing crystalline silica. Silica is a basic component of sand, quartz, brick clay, granite and numerous other minerals and rocks. Repeated and/or substantial inhalation of airborne crystalline silica can cause serious or fatal respiratory diseases, including silicosis. In addition, California and some other authorities have listed respirable crystalline silica as a substance known to cause cancer. When cutting such materials, always follow the respiratory precautions mentioned above.

! WARNING



RESPIRATORY HAZARDS

Grinding/cutting/drilling of masonry, concrete, metal and other materials can generate dust, mists and fumes containing chemicals known to cause serious or fatal injury or illness, such as respiratory disease, cancer, birth defects or other reproductive harm. If you are unfamiliar with the risks associated with the particular process and/or material being cut or the composition of the tool being used, review the material safety data sheet and/or consult your employer, the material manufacturer/supplier, governmental agencies such as OSHA and NIOSH and other sources on hazardous materials. California and some other authorities, for instance, have published lists of substances known to cause cancer, reproductive toxicity, or other harmful effects.

Control dust, mist and fumes at the source where possible. In this regard use good work practices and follow the recommendations of the manufacturers or suppliers, OSHA/NIOSH, and occupational and trade associations. Water should be used for dust suppression when wet cutting is feasible. When the hazards from inhalation of dust, mists and fumes cannot be eliminated, the operator and any bystanders should always wear a respirator approved by NIOSH/MSHA for the materials being used.

TABLE OF CONTENTS

HHNG5 Ride-On Trowel

- Proposition 65 Warning 2
- Silicosis/Respiratory Warnings 3
- Table of Contents..... 4
- Training Checklist 6
- Daily Pre-Operation Checklist 7
- Safety Information 8–14
- Lifting and Transporting 15–17
- Specifications 18
- Dimensions..... 19
- General Information..... 20–21
- Components 22–23
- Basic Engine..... 24
- Setup 25–26
- Inspection 27
- Operation..... 28–30
- Maintenance 31–45
- Troubleshooting (Trowel)..... 46–47
- Troubleshooting (Engine) 48–49

DISCLAIMER:
Product features, descriptions, and specifications are based on published information at the time of publication and are subject to change at any time without notice. Multiquip Inc. and its affiliates reserve the right to change specifications, features, design, and descriptions of products at any time without notice.

TRAINING CHECKLIST

Training Checklist			
No.	Description	OK?	Date
1	Read operation manual completely.		
2	Machine layout, location of components, checking of engine oil level.		
3	Fuel system, refueling procedure.		
4	Operation of spray and lights.		
5	Operation of controls (machine not running).		
6	Safety controls, safety stop switch operation.		
7	Emergency stop procedures.		
8	Startup of machine, pre-heat, engine choke.		
9	Maintaining a hover.		
10	Maneuvering.		
11	Pitching.		
12	Matching blade pitch. Twin-Pitch™		
13	Concrete finishing techniques.		
14	Shutdown of machine.		
15	Lifting of machine (lift loops).		
16	Machine transport and storage.		

DAILY PRE-OPERATION CHECKLIST

Daily Pre-Operation Checklist		✓	✓	✓	✓	✓	✓
1	Engine oil level						
2	Radiator coolant level						
3	Condition of blades						
4	Blade pitch operation						
5	Safety stop switch operation						
6	Steering control operation						

SAFETY INFORMATION

Do not operate or service the equipment before reading the entire manual. Safety precautions should be followed at all times when operating this equipment. Failure to read and understand the safety messages and operating instructions could result in injury to yourself and others.



SAFETY MESSAGES

The four safety messages shown below will inform you about potential hazards that could injure you or others. The safety messages specifically address the level of exposure to the operator and are preceded by one of four words: **DANGER**, **WARNING**, **CAUTION** or **NOTICE**.

SAFETY SYMBOLS

! DANGER

Indicates a hazardous situation which, if not avoided, **WILL** result in **DEATH** or **SERIOUS INJURY**.

! WARNING

Indicates a hazardous situation which, if not avoided, **COULD** result in **DEATH** or **SERIOUS INJURY**.

! CAUTION

Indicates a hazardous situation which, if not avoided, **COULD** result in **MINOR** or **MODERATE INJURY**.

NOTICE

Addresses practices not related to personal injury.

Potential hazards associated with the operation of this equipment will be referenced with hazard symbols which may appear throughout this manual in conjunction with safety messages.









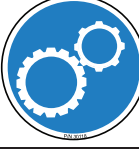

Symbol	Safety Hazard
	Lethal exhaust gas hazards
	Explosive fuel hazards
	Burn hazards
	Rotating parts hazards
	Pressurized fluid hazards
	Hydraulic fluid hazards

SAFETY INFORMATION

DECALS

Decals associated with the operation of this equipment are defined below.

DECAL	DEFINITION
	DANGER Flying Objects Hazard DO NOT disassemble spring cylinders without qualified service personnel. Possibility exists of severe bodily harm and injury .
	DANGER Guard Hazard DO NOT operate equipment with guards removed. Serious bodily injury could result.
	DANGER No Water Warning DO NOT add water to the retardant tank.
	DANGER Belt Guard Hazard DO NOT remove belt guards. Keep hands and fingers clear from engine belts. Moving parts can crush.
	DANGER Training This machine to be operated by qualified personnel only. Ask for training as needed.
	DANGER Inhalation Hazard DO NOT use this equipment in an enclosed area . The engine used with this equipment emits harmful levels of carbon monoxide which can cause severe bodily harm — even death!
	DANGER Rotating Blade Hazard Keep hands, fingers, and feet clear of engine fan blades and guard rings. Moving parts can cut. DO NOT remove guards. Stop engine before servicing.
	WARNING Fire, Smoking, Explosion, Inhalation Hazard DO NOT smoke or light matches near this equipment. This equipment contains highly flammable fuel. DO NOT use this equipment in an enclosed area.

DECAL	DEFINITION
	WARNING Entanglement/Crush Hazard DO NOT operate equipment with guards removed. Serious bodily injury could result. Keep hands and fingers clear of gears.
	WARNING Lifting/Crush Hazard NEVER allow any person to stand underneath the trowel while lifting. DO NOT lift trowel with pans attached. ALWAYS make sure handle is securely attached.
	CAUTION Burn Hazard HOT PARTS can burn skin. DO NOT touch hot parts . Allow machine sufficient amount of time to cool before performing maintenance.
	NOTICE Read Manual To avoid injury, you must read and understand the operator's manual before using this machine.
	NOTICE Protective Clothing ALWAYS wear appropriate clothing when operating the trowel.
	NOTICE Visual Inspection Visually inspect designated locations before operating trowel. Check that all components are in appropriate operating condition.
	NOTICE Lifting Location Attach a suitable lifting device here to lift the unit.
	NOTICE Tie-Down Location ALWAYS tie-down equipment with rope during transport.
	NOISE LEVEL Indicates value of the sound power of the equipment measured at operator's seat.
	UNLEADED GASOLINE The engine used in this equipment runs on unleaded gasoline .

SAFETY INFORMATION

GENERAL SAFETY

CAUTION

- **NEVER** operate this equipment without proper protective clothing, shatterproof glasses, respiratory protection, hearing protection, steel-toed boots and other protective devices required by the job or city and state regulations.



- Avoid wearing jewelry or loose fitting clothes that may snag on the controls or moving parts as this can cause serious injury.

- **NEVER** operate this equipment when not feeling well due to fatigue, illness or when under medication.



- **NEVER** operate this equipment under the influence of drugs or alcohol.



- **ALWAYS** clear the work area of any debris, tools, etc. that would constitute a hazard while the equipment is in operation.
- No one other than the operator is to be in the working area when the equipment is in operation.
- **DO NOT** use the equipment for any purpose other than its intended purposes or applications.

NOTICE

- This equipment should only be operated by trained and qualified personnel 18 years of age and older.
- Whenever necessary, replace nameplate, operation and safety decals when they become difficult read.
- Manufacturer does not assume responsibility for any accident due to equipment modifications. Unauthorized equipment modification will void all warranties.

- **NEVER** use accessories or attachments that are not recommended by Multiquip for this equipment. Damage to the equipment and/or injury to user may result.

- **ALWAYS** know the location of the nearest fire extinguisher.



- **ALWAYS** know the location of the nearest first aid kit.



- **ALWAYS** know the location of the nearest phone or **keep a phone on the job site**. Also, know the phone numbers of the nearest **ambulance, doctor** and **fire department**. This information will be invaluable in the case of an emergency.



TROWEL SAFETY

DANGER

- Engine fuel exhaust gases contain poisonous carbon monoxide. This gas is colorless and odorless, and can cause death if inhaled.

- The engine of this equipment requires an adequate free flow of cooling air. **NEVER** operate this equipment in any enclosed or narrow area where free flow of the air is restricted. If the air flow is restricted it will cause injury to people and property and serious damage to the equipment or engine.



- **NEVER** operate the equipment in an explosive atmosphere or near combustible materials. An explosion or fire could result causing severe **bodily harm or even death**.



SAFETY INFORMATION

WARNING

- If applicable, **NEVER** use your hand to find hydraulic leaks. Use a piece of wood or cardboard. Hydraulic fluid injected into the skin must be treated by a knowledgeable physician immediately or severe injury or death can occur.



- **ALWAYS** keep clear of rotating or moving parts while operating the trowel.



- **NEVER** disconnect any **emergency or safety devices**. These devices are intended for operator safety. Disconnection of these devices can cause severe injury, bodily harm or even death. Disconnection of any of these devices will void all warranties.

CAUTION

- **NEVER** allow passengers or riders on the trowel during operation.
- **NEVER** lubricate components or attempt service on a running machine.
- **NEVER** place your feet or hands inside the guard rings while starting or operating this equipment.

NOTICE

- **ALWAYS** keep the machine in proper running condition.
- Fix damage to machine and replace any broken parts immediately.
- **ALWAYS** store equipment properly when it is not being used. Equipment should be stored in a clean, dry location out of the reach of children and unauthorized personnel.
- A safety manual for operating and maintenance personnel of concrete power trowels produced by the Association of Equipment Manufacturers (AEM) can be obtained for a fee by ordering through their website at www.aem.org.

Order FORM PT-160

ENGINE SAFETY

WARNING

- **DO NOT** place hands or fingers inside engine compartment when engine is running.
- **NEVER** operate the engine with heat shields or guards removed.
- Keep fingers, hands hair and clothing away from all moving parts to prevent injury.
- **DO NOT** remove the radiator cap while the engine is hot. High pressure boiling water will gush out of the radiator and severely scald any persons in the general area of the trowel.
- **DO NOT** remove the coolant drain plug while the engine is hot. Hot coolant will gush out of the coolant tank and severely scald any persons in the general area of the trowel.
- **DO NOT** remove the engine oil drain plug while the engine is hot. Hot oil will gush out of the oil tank and severely scald any persons in the general area of the trowel.



CAUTION

- **NEVER** touch the hot exhaust manifold, muffler or cylinder. Allow these parts to cool before servicing equipment.



NOTICE

- **NEVER** run engine without an air filter or with a dirty air filter. Severe engine damage may occur. Service air filter frequently to prevent engine malfunction.
- **NEVER** tamper with the factory settings of the engine or engine governor. Damage to the engine or equipment can result if operating in speed ranges above the maximum allowable.



SAFETY INFORMATION

FUEL SAFETY

DANGER

- **DO NOT** start the engine near spilled fuel or combustible fluids. Fuel is extremely flammable and its vapors can cause an explosion if ignited.
- **ALWAYS** refuel in a well-ventilated area, away from sparks and open flames.
- **ALWAYS** use extreme caution when working with **flammable** liquids.
- **DO NOT** fill the fuel tank while the engine is running or hot.
- **DO NOT** overfill tank, since spilled fuel could ignite if it comes into contact with hot engine parts or sparks from the ignition system.
- Store fuel in appropriate containers, in well-ventilated areas and away from sparks and flames.
- **NEVER** use fuel as a cleaning agent.
- **DO NOT** smoke around or near the equipment. Fire or explosion could result from fuel vapors or if fuel is spilled on a hot engine.





BATTERY SAFETY

DANGER

- **DO NOT** drop the battery. There is a possibility that the battery will explode.
- **DO NOT** expose the battery to open flames, sparks, cigarettes, etc. The battery contains combustible gases and liquids. If these gases and liquids come into contact with a flame or spark, an explosion could occur.



WARNING

- **ALWAYS** wear safety glasses when handling the battery to avoid eye irritation. The battery contains acids that can cause injury to the eyes and skin.
- 
- Use well-insulated gloves when picking up the battery.
 - **ALWAYS** keep the battery charged. If the battery is not charged, combustible gas will build up.
 - **DO NOT** charge battery if frozen. Battery can explode. When frozen, warm the battery to at least 61°F (16°C).
 - **ALWAYS** recharge the battery in a well-ventilated environment to avoid the risk of a dangerous concentration of combustible gases.
 - If the battery liquid (dilute sulfuric acid) comes into contact with **clothing or skin**, rinse skin or clothing immediately with plenty of water.
- 
- If the battery liquid (dilute sulfuric acid) comes into contact with **eyes**, rinse eyes immediately with plenty of water and contact the nearest doctor or hospital to seek medical attention.

CAUTION

- **ALWAYS** disconnect the **NEGATIVE** battery terminal before performing service on the equipment.
- **ALWAYS** keep battery cables in good working condition. Repair or replace all worn cables.

TRANSPORTING SAFETY

CAUTION

- **NEVER** allow any person or animal to stand underneath the equipment while lifting.
- Ride-on trowels are very heavy and awkward to move around. Use proper heavy lifting procedures and **DO NOT** attempt to lift the trowel by the guard rings.



SAFETY INFORMATION

NOTICE

- The easiest way to lift the trowel is to utilize the lift loops that are welded to the frame. These lift loops are located to the left and right sides of the operator's seat.

A strap or chain can be attached to these lift loops, allowing a forklift or crane to lift the trowel up onto and off of a slab of concrete. The strap or chain should have a minimum of 2,000 pounds (1,000 kg) lifting capacity and the lifting gear must be capable of lifting at least this amount.

- **NEVER** transport trowel with float pans attached unless safety catches are used and are specifically cleared for such transport by the manufacturer.
- **NEVER** hoist the trowel more than three feet off the ground with float pans attached.
- Before lifting, make sure that the lift loops are not damaged.
- Always make sure crane or lifting device has been properly secured to the lift loops of the equipment.
- **ALWAYS** shutdown engine before transporting.
- **NEVER** lift the equipment while the engine is running.
- Tighten fuel tank cap securely and close fuel cock to prevent fuel from spilling.
- Use adequate lifting cable (wire or rope) of sufficient strength.
- **DO NOT** lift machine to unnecessary heights.
- **ALWAYS** tie down equipment during transport by securing the equipment with rope.

TOWING SAFETY

⚠ CAUTION

- Check with your local county or state safety towing regulations, in addition to meeting **Department of Transportation (DOT) Safety Towing Regulations**, before towing your trowel. 
- In order to reduce the possibility of an accident while transporting the trowel on public roads, **ALWAYS** make sure the trailer that supports the trowel and the towing vehicle are mechanically sound and in good operating condition.
- **ALWAYS** shutdown engine before transporting
- Make sure the hitch and coupling of the towing vehicle are rated equal to, or greater than the trailer "gross vehicle weight rating."
- **ALWAYS** inspect the hitch and coupling for wear. **NEVER** tow a trailer with defective hitches, couplings, chains, etc.
- Check the tire air pressure on both towing vehicle and trailer. **Trailer tires should be inflated to 50 psi cold.** Also check the tire tread wear on both vehicles.
- **ALWAYS** make sure the trailer is equipped with a **safety chain**.
- **ALWAYS** properly attach trailer's safety chains to towing vehicle.
- **ALWAYS** make sure the vehicle and trailer directional, backup, brake and trailer lights are connected and working properly.
- DOT Requirements include the following:
 - Connect and test electric brake operation.
 - Secure portable power cables in cable tray with tie wraps.
- The maximum speed for highway towing is 55 MPH unless posted otherwise. Recommended off-road towing is not to exceed 15 MPH or less depending on type of terrain.
- Avoid sudden stops and starts. This can cause skidding, or jack-knifing. Smooth, gradual starts and stops will improve towing.
- Avoid sharp turns to prevent rolling.

SAFETY INFORMATION

- Trailer should be adjusted to a level position at all times when towing.
- Raise and lock trailer wheel stand in up position when towing.
- Place **chock blocks** underneath wheel to prevent rolling while parked.
- Place support blocks underneath the trailer's bumper to prevent tipping while parked.
- Use the trailer's swivel jack to adjust the trailer height to a level position while parked.

ENVIRONMENTAL SAFETY/DECOMMISSIONING

NOTICE

Decommissioning is a controlled process used to safely retire a piece of equipment that is no longer serviceable. If the equipment poses an unacceptable and unreparable safety risk due to wear or damage or is no longer cost effective to maintain (beyond life-cycle reliability) and is to be decommissioned (demolition and dismantlement), be sure to follow rules below.

- **DO NOT** pour waste or oil directly onto the ground, down a drain or into any water source.
- Contact your country's Department of Public Works or recycling agency in your area and arrange for proper disposal of any electrical components, waste or oil associated with this equipment.
- When the life cycle of this equipment is over, remove battery and bring to appropriate facility for lead reclamation. Use safety precautions when handling batteries that contain sulfuric acid.
- When the life cycle of this equipment is over, it is recommended that the trowel frame and all other metal parts be sent to a recycling center.



Metal recycling involves the collection of metal from discarded products and its transformation into raw materials to use in manufacturing a new product.

Recyclers and manufacturers alike promote the process of recycling metal. Using a metal recycling center promotes energy cost savings.

EMISSIONS INFORMATION

NOTICE

The gasoline engine used in this equipment has been designed to reduce harmful levels of carbon monoxide (CO), hydrocarbons (HC) and nitrogen oxides (NOx) contained in diesel exhaust emissions.

This engine has been certified to meet US EPA Evaporative emissions requirements in the installed configuration.

Attempting to modify or make adjustments to the engine emission system by unauthorized personnel without proper training could damage the equipment or create an unsafe condition.

Additionally, modifying the fuel system may adversely affect evaporative emissions, resulting in fines or other penalties.

Emission Control Label

The emission control label is an integral part of the emission system and is strictly controlled by regulations.

The label must remain with the engine for its entire life.

If a replacement emission label is needed, please contact your authorized Yanmar Engine Distributor.

LIFTING AND TRANSPORTING

WORK SAFELY!

WARNING



Failure to comply with these lifting instructions may result in **slings failure** and **severe personal injury or death**.

Only **qualified personnel** with proper training should perform this procedure. Follow all rigging and lifting safety rules when performing this procedure.

LIFTING SAFETY

CAUTION

- **NEVER** allow any person to stand underneath the equipment while lifting.
- Ride-on trowels are very heavy and awkward to move around. Use proper heavy lifting procedures and **DO NOT** attempt to lift the trowel by the guard rings.
- **NEVER** lift the trowel with the operator on the machine.

NOTICE

- **NEVER** hoist the trowel more than three feet off of the ground with float pans attached.
- Before lifting, make sure that the lift loops are not damaged.
- **ALWAYS** make sure any lifting device has been properly secured to the lift loops of the trowel.
- **DO NOT** lift the trowel to unnecessary heights.
- **ALWAYS** shut down the engine before transporting.
- **NEVER** lift the trowel while the engine is running.
- Tighten the fuel tank cap securely and close the fuel cock to prevent fuel from spilling.

SLING INSPECTION

Inspect the lifting slings provided with your trowel (Figure 1) **before each use**. If replacement slings are needed, refer to the parts manual included with your trowel for part numbers, and order from your Multiquip parts dealer or importer.

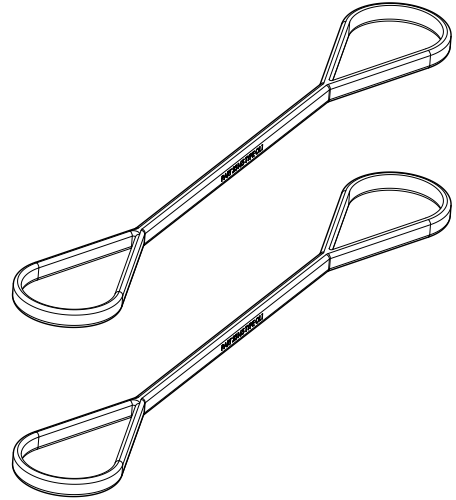
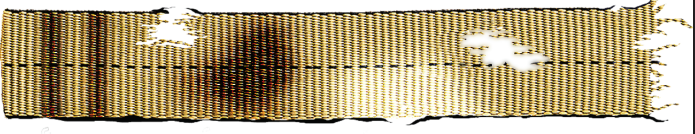

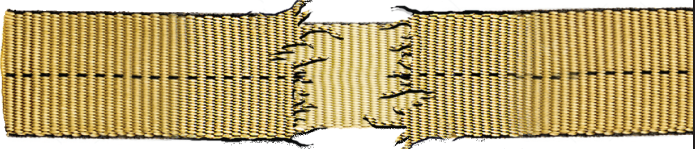
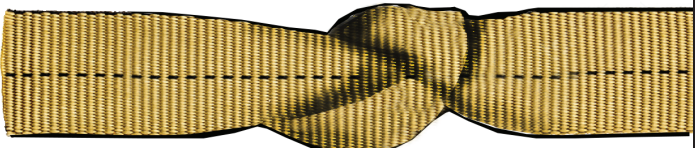

Figure 1. Lifting Slings

LIFTING AND TRANSPORTING

The Occupational Safety and Health Administration (OSHA) Regulation 29 CFR Part 1926.251 (e)(8)—*Removal from service* requires that the slings be inspected prior to each use, and **removed from service immediately** if any of the following conditions are found:

<ul style="list-style-type: none"> ■ Holes, tears, cuts, or snags ■ Embedded particles ■ Abrasive wear that exposes core fibers 	
<ul style="list-style-type: none"> ■ Missing or unreadable Rated Capacity tags ■ Melting, charring, weld spatter, or chemical burns 	
<ul style="list-style-type: none"> ■ Broken or worn stitching that exposes the core fibers 	
<ul style="list-style-type: none"> ■ Knots 	
<ul style="list-style-type: none"> ■ Any other condition which may cause doubt as to the strength of the sling 	

LIFTING AND TRANSPORTING

LIFTING PROCEDURE

The correct lifting slings (Figure 1) have been supplied with your trowel, in accordance to its weight per Occupational Safety and Health Administration (OSHA) Regulation 29 CFR Part 1926.251—*Rigging equipment for material handling*.

WARNING
ALWAYS inspect the lifting slings **before** each use.

NOTICE
MAKE SURE the forklift has adequate lifting capacity to lift the trowel.

The proper sling hitch method for connecting the lifting slings to the ride-on trowel is the **choker hitch**. The rated capacity of the slings for this method is indicated on the sling labels. **DO NOT** use any other type of sling hitch!

1. Secure the two lifting slings to the lift loops located on the left and right side of the trowel (Figure 2).

2. Insert forklift forks through the loops at the ends of the lifting slings (Figure 2). Keep the slings as close to vertical as possible. If the choke angle (Figure 3) is 120 degrees or less, the lifting strength of the slings must be de-rated as shown in Table 1, in accordance with ASME Standard B30.9.

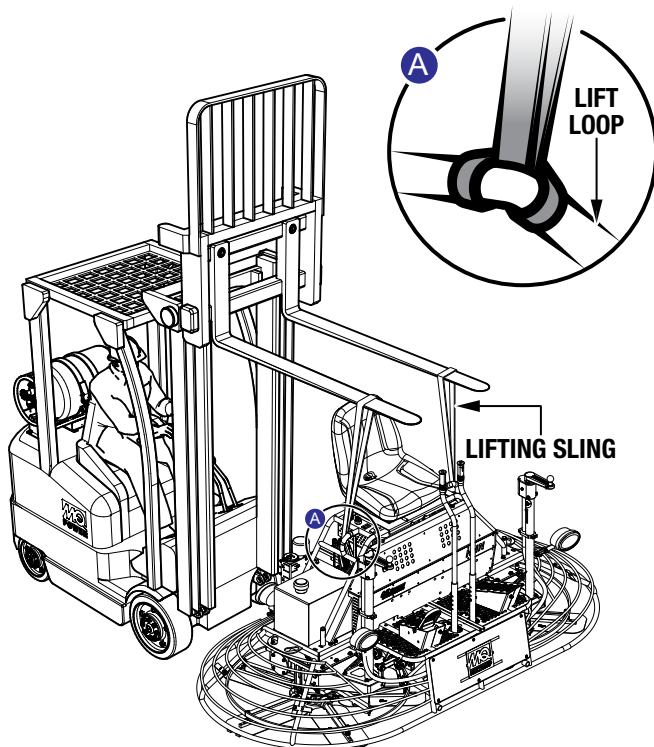

Figure 2. Lifting the Trowel

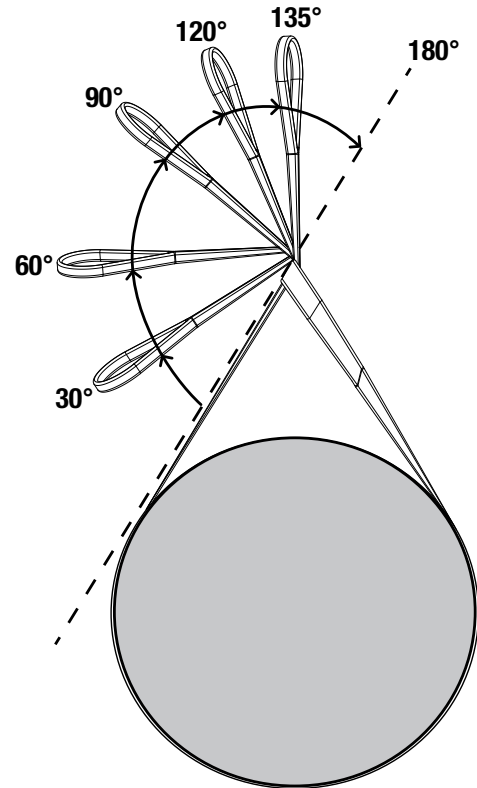

Figure 3. Choke Angle

Table 1. Choker Hitch Sling Capacity	
Choke Angle (°)	Rated Capacity (%)
Over 120	100
90–120	87
60–89	74
30–59	62
0–29	49

SPECIFICATIONS

Table 2. HHNG5 Specifications

Operating Weight	1,083 lb. (495 kg)
Shipping Weight	1,368 lb. (620 kg)
Fuel Tank Capacity	5 gallons (19 liters)
Rotor Speed	0–180 rpm
Path Width	92 in. (233 cm)
Gearbox Oil Capacity	144 oz. (4.26 liters)
Gearbox Oil Type	ISO 220 AGMA GR 5EP

Table 3. Engine Specifications

Model	Briggs & Stratton Vanguard Model 540000
Type	OHV, air-cooled, gasoline engine
Cylinders	2
Piston Displacement	54.88 in. ³ (896 cm ³)
Bore × Stroke	3.36 × 3.07 in. (85 × 78 mm)
Maximum Output	35 bhp (26 kW) @ 3,600 rpm
Maximum Torque	58.3 lbf-ft. (26.4 kg) at 2,300 rpm
Engine Oil Type	SAE 30, 10W-30, 5W-30 or SF, SG, SH, SJ or higher
Engine Oil Capacity	2.5 qt. (2.36 liters)
Lubricating System	Pressure feed with spin-on filter
Fuel Type	Gasoline, minimum 87 octane rating
Starting System	12 VDC electric start
Resistor Spark Plug Type	B&S 692051
Spark Plug Gap	.030 in. (0.76 mm)
Dimensions (L × W × H)	20 × 19 × 28 in. (508 × 483 × 711 mm)
Shipping Weight	149 lb. (67.5 kg)

Table 4. HHNG5 Noise and Vibration Emissions

Guaranteed ISO 11201:2010 Based Sound Pressure Level at Operator Station in dB(A) ^a	91
Guaranteed ISO 3744:2010 Based Sound Power Level in dB(A) ^b	106
Whole Body Vibration per ISO 2631-1:1997 +A1:2010 in m/s ² ΣA(8))	0.03

a. With an uncertainty factor K of 2.5 dB (A) included per Note 1 in section 7.2.1 of EN 12649:2008+A1:2011
 b. With an uncertainty factor K of 1.5 dB (A) included per Note 1 in section 7.2.1 of EN 12649:2008+A1:2011

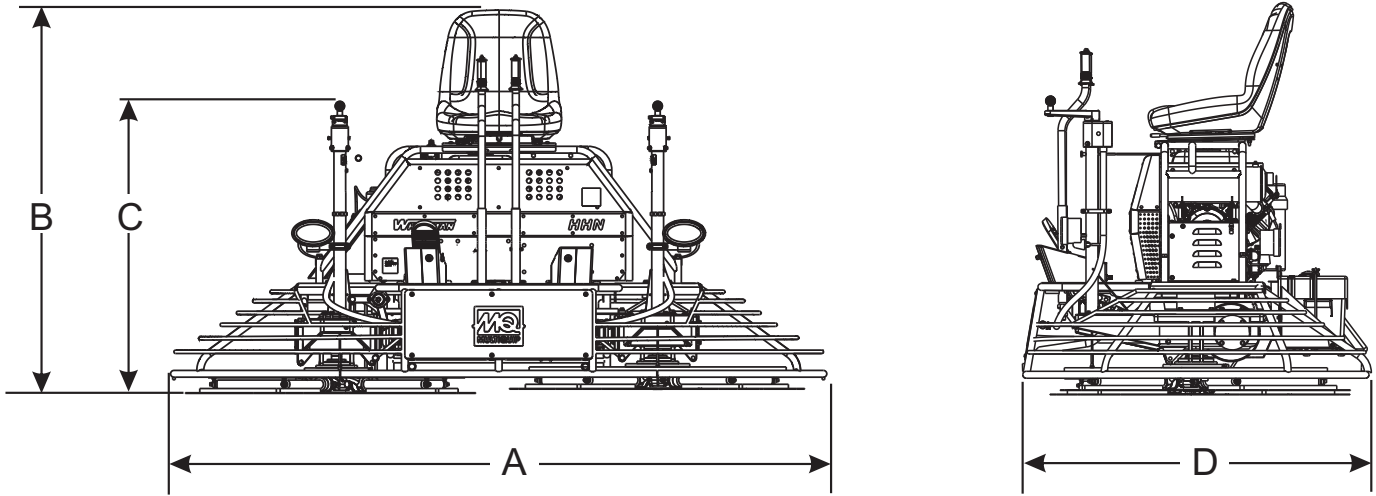

Figure 4. HHNG5 Dimensions

Table 5. HHNG5 Dimensions	
Measurement	in. (cm)
(A) Length	97 (246)
(B) Height (seat)	50 (127)
(C) Height (crank handle)	46 (117)
(D) Width	46 (117)

HHNG5 RIDE-ON POWER TROWEL FAMILIARIZATION

This Ride-On Power Trowel is designed for the floating and finishing of concrete slabs.

Take a walk around your trowel. Take notice of all the major components (see Figure 5 and Figure 6) like the engine, blades, air cleaner, fuel system, fuel shut-off valve, ignition switch, etc. Ensure engine and gearbox lubricant levels are within proper operating range.

Read all the safety instructions carefully. Safety instructions will be found throughout this manual and on the machine. Keep all safety information in good, readable condition. Operators should be well trained on the operation and maintenance of the trowel.

Look at the operator control levers. Grasp the control levers and move them around a bit. Observe how moving the control levers causes the gearboxes and frame to move.

Notice the foot pedal which controls the engine and blade speed. Also take a look at the main driveline of the trowel. Take note and reference the drive belt alignment—this is the way the belt should be aligned when adjusted properly.

Before using your trowel, test it on a flat, watered-down section of finished concrete. This trial test run will increase your confidence in using the trowel, and at the same time, it will familiarize you with the trowel's controls and indicators. In addition, you will understand how the trowel will handle under actual conditions.

Engine

This trowel is equipped with a Briggs and Stratton Vanguard air-cooled, V-twin big block, 35 hp, gasoline engine. Refer to the engine owner's manual for specific instructions regarding engine operation. This manual is included with the trowel at the time of shipping. Please contact your nearest Multiquip dealer should a replacement manual be required.

Blades

The blades of the trowel finish the concrete as they are swirled around the surface. Blades are classified as *combination* (10 or 8 inches wide) or *finish* (6 inches wide). This trowel is equipped with five blades per rotor equally spaced in a radial pattern and attached to a vertical rotating shaft by means of a spider assembly.

Twin Pitch Control™

The Twin Pitch™ control feature allows the operator to simultaneously control the pitch of both rotors with minimal effort, yet still allows for individual pitch control.

Helical Gearboxes

This trowel is designed with two separate helical gearbox assemblies that are enclosed in rugged cast aluminum gear cases.

Steering

Dual control levers located in front of the operator's seat are provided for steering this trowel. The control levers are linked to two spring-loaded cylinders. In addition, a **steering assist** feature has been provided to make controlling of the trowel easier especially when float pans are installed.

Push the left control lever forward and pull the right control lever backward and the trowel will rotate clockwise on approximately a center axis. Pull the left control lever backward and push the right control lever forward and the trowel will rotate counterclockwise. See Table 8 for a complete description of the control levers' directional positioning.

Constant Velocity Joints (CV-Joints)

Constant velocity joints ensure the efficient transfer of power to the drive shaft and maintain the timing of the gearboxes without any chance of slippage.

Continuously Variable Transmission (CVT)

A Continuously Variable Transmission (CVT) has been installed to obtain maximum drive torque.

This is accomplished by continually adjusting the drive ratio to obtain optimum torque and speed during all phases of finishing from low speed/high torque to high speed burnishing.

How It Works

The Multi-Clutch functions much like a standard CVT system. As the engine RPMs increase, the drive or primary clutch closes, forcing the belt to ride outwards on the drive sheaves. The closing of the drive clutch also forces the belt to open the driven or secondary sheaves. The opening and closing of these sheaves creates a ratio variation—hence CVT or Continuously Variable Transmission.

Belt protection is achieved within the Multi-Clutch through the use of a series of centrifugal clutches. While most CVT systems have a loose or slack belt while the engine idles, the sheaves of those systems are constantly rotating and wearing on the belt.

Those systems also require the stationary belt to be pinched by the constantly rotating sheaves during startup. The relative rotation of the sheaves to the belt causes unnecessary wear on the belt. With traditional CVT systems, wear on the belt happens any time the engine is idling and at every startup of the driven equipment. This is where the Multi-Clutch differs from other CVTs.

The Multi-Clutch utilizes two centrifugal clutches (the starter clutch system) to drive the sheaves of the drive (primary) clutch. What that means is that the belt can remain tight in the sheaves, and that both the sheaves and the belt are stationary while the vehicle is idling. This eliminates the belt wear at idle and during startup, while also providing one additional form of belt protection.

The centrifugal clutches (starter clutch) can act as overload protection as well. In cases where too much torque is being transmitted to the belt, the centrifugals can slip before the maximum load on the belt is achieved. What this means is that instead of the belt slipping on the sheaves during an overload, the centrifugals will slip first, further protecting the belt from damage.

Training

For training, please use the *Training Checklist* located in the front of this manual. This checklist is not intended to be a substitute for proper training but will provide an outline for an experienced operator to provide training to a new operator.

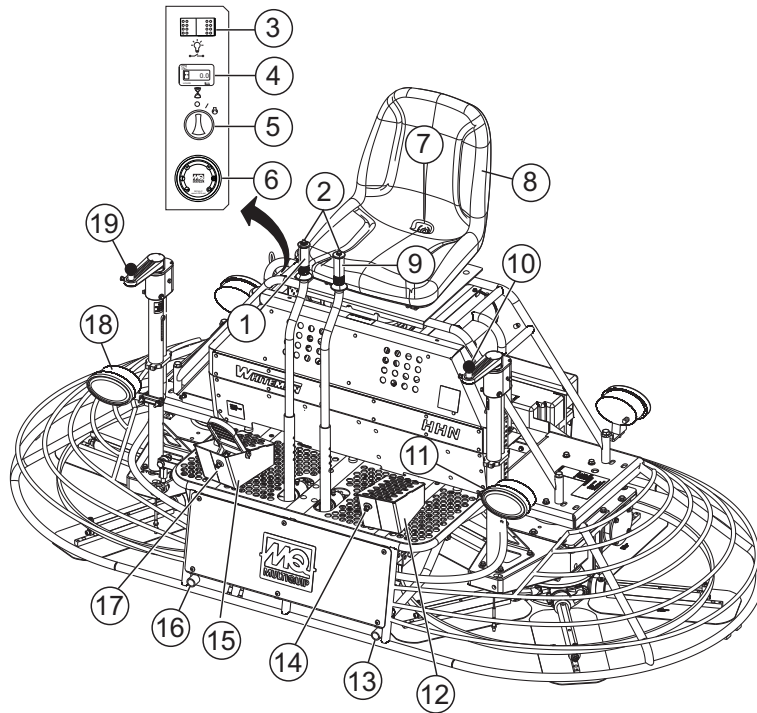

Figure 5. HHNG5 Components (Front)

1. **Steering Control Lever (Right Side)** — Allows the unit to move in either a forward, reverse, left or right direction.
2. **Retardant Spray Control Buttons** — When pressed, allows retardant spray to flow through the spray nozzle located at the front of the machine.
3. **Light Switch** — When activated, turns on four halogen lights. Lights offer better visibility when working indoors.
4. **Hour Meter** — Indicates the number of hours the key switch is in the **ON** position.
5. **Ignition Switch** — With the key inserted, turn clockwise to start the engine.
6. **Oil, Temperature and Charge Indicator Display** — Will illuminate when oil pressure is low, water temperature is high, or the electrical system is not charging properly.
7. **Safety Stop Switch** — Shuts down the engine when the operator is not sitting in the seat.
8. **Seat** — Provides a comfortable position for operation of the trowel. The engine will not start unless the operator is seated. Seat is adjustable, fore and aft, for operator comfort.
9. **Steering Control Lever (Left Side)** — Allows the unit to move in either a forward, reverse, left or right direction
10. **Twin Pitch Control (Left)** — Adjusts blade pitch for the left side of the trowel. Turn the crank as marked on its top surface to increase or decrease blade pitch.
11. **Left Front Light** — 55-watt, 12 VDC, halogen light is provided for night time and indoor work.
12. **Left Foot Riser** — Operator foot rest pedal.
13. **EZ-Mover Boss** — Insertion point (left-front) for EZ Mover. Used when transporting of the trowel is required.
14. **Left-Front Spray Nozzle** — Spray nozzle for retardant.
15. **Right Foot Pedal** — Controls blade speed. Slow blade speed is accomplished by slightly depressing the foot pedal. Maximum blade speed is accomplished by fully depressing the foot pedal.
16. **EZ-Mover Boss** — Insertion point (right-front) for EZ Mover. Used when transporting of the trowel is required.
17. **Right-Front Spray Nozzle** — Spray nozzle for retardant.
18. **Right Front Light** — 55-watt, 12 VDC, halogen light is provided for night time and indoor work.
19. **Twin Pitch Control (Right)** — Adjusts blade pitch for the right side of the trowel. Turn the crank as marked on its top surface to increase or decrease blade pitch.

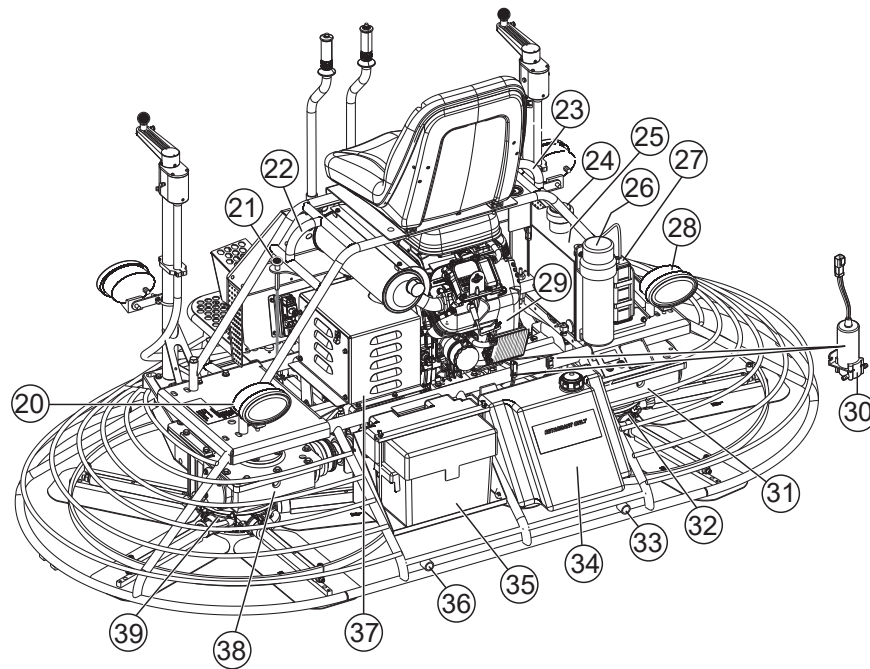

Figure 6. HHNG5 Components (Rear)

- 20. **Left Rear Light** — 55-watt, 12 VDC, halogen light is provided for night time and indoor work.
- 21. **Choke Knob** — Used in the starting of a cold engine, or in cold weather conditions. The choke enriches the fuel mixture.
- 22. **Left-Side Lift Loop** — Attach a strap of adequate lifting capacity to this loop when the trowel must be lifted.
- 23. **Right-Side Lift Loop** — Attach a strap of adequate lifting capacity to this loop when the trowel must be lifted.
- 24. **Fuel Tank** — Holds 5 gallons of fuel. Use unleaded fuel.
- 25. **Fuel Gauge/Filler Cap** — Indicates the amount of fuel in the fuel tank. Remove this cap to add fuel.
- 26. **Documentation Holder** — Contains the operation manual and other documents relating to the trowel.
- 27. **Charcoal Canister** — A container filled with activated charcoal that traps gasoline vapors emitted by the fuel system.
- 28. **Left Rear Light** — 55-watt, 12 VDC, halogen light is provided for night time and indoor work.
- 29. **Engine** — This trowel uses a Briggs and Stratton, Vanguard 35 hp gasoline engine.
- 30. **Right and Left Side Retardant Spray Pumps** — Delivers retardant to the spray nozzles.
- 31. **Right-Side Hydraulic Oil Sight Glass** — Indicates the level of the hydraulic oil in the right-side gearbox.
- 32. **Right-Side Spider** — Consists (basic) of trowel arms, blades, wear plate, and thrust collar.
- 33. **EZ-Mover Boss** — Insertion point (right-rear) for EZ Mover. Used when transporting of the trowel is required.
- 34. **Retardant Spray Tank** — Holds 5 gallons of retardant.
- 35. **Battery** — Provides +12V DC power to the electrical system.
- 36. **EZ-Mover Boss** — Insertion point (left-rear) for EZ Mover. Used when transporting of the trowel is required.
- 37. **Belt Guard** — Encloses the drive belt used in conjunction with the clutch. A spare drive belt is also enclosed inside this guard.
- 38. **Left-Side Hydraulic Oil Sight Glass** — Indicates the level of the hydraulic oil in the left-side gearbox.
- 39. **Left-Side Spider** — Consists (basic) of trowel arms, blades, wear plate, and thrust collar.

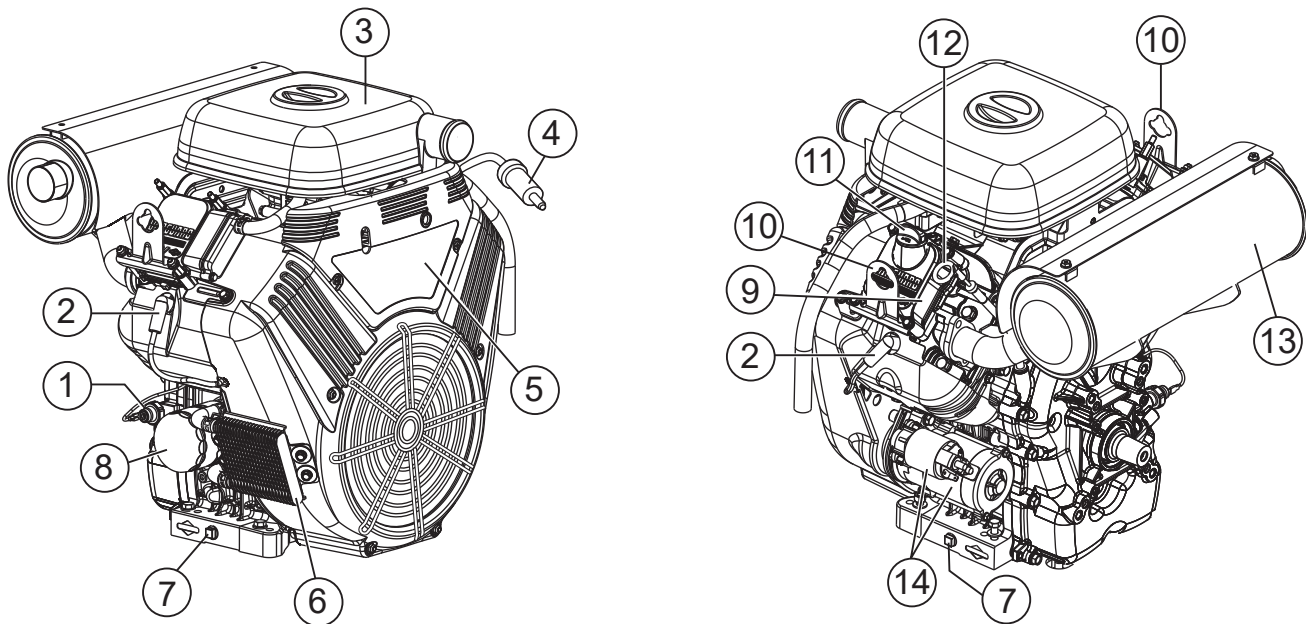

Figure 7. Basic Engine Components

INITIAL SERVICING

The gasoline engine (Figure 7) must be checked for proper lubrication and filled with fuel prior to operation. Refer to the manufacturer's engine manual for instructions and details of operation and servicing.

1. **Oil Pressure Sensor** — Monitors engine oil pressure.
2. **Side Spark Plug (2)** — Provides spark to the ignition system. Set the spark plug gap to 0.030 inch (0.7 mm). Clean the spark plug once a week.
3. **Air Filter** — Prevents dirt and other debris from entering the fuel system. Unsnap the air filter cover to gain access to the filter element.
4. **In-Line Fuel Filter** — Filters fuel for contaminants.
5. **Engine** — Briggs and Stratton, Vanguard 35 hp, air-cooled, big block gasoline engine.
6. **Engine Oil Cooler** — Continuously provides cool oil for the lubricating system.
7. **Oil Drain Plug (2)** — Remove to drain crankcase oil. Always dispose of used oil and oil filters in an environmentally safe manner. **DO NOT** allow used oil to drain onto the ground or into a water runoff drain.
8. **Oil Filter** — Spin-on type, filters oil for contaminants.
9. **Engine Tag** — Provides engine model identification and information.
10. **Lifting Bail (2)** — When lifting of the engine is required attach a strap or chain of adequate lifting capacity to these lifting points.
11. **Oil Filler Cap** — Remove to add engine oil. Refer to Table 3 and Table 7 when adding engine oil.
12. **Oil Dip Stick** — Remove to check the amount and condition of oil in the crankcase.
13. **Muffler** — Reduces noise and emissions.
14. **Starter** — Starts the engine when the ignition key is rotated to the **START** position.

WARNING



Engine components can generate extreme heat. To prevent burns, **DO NOT** touch these areas while the engine is running or immediately after operating. **NEVER** operate the engine with the muffler removed.

The purpose of this section is to assist the user in setting up a **NEW** trowel. If your trowel is already assembled (seat, handles, knobs, and battery), this section can be skipped.

NOTICE

The new trowel cannot be placed into service until the setup installation instructions are completed.

Before packaging and shipping, this ride-on power trowel was run and tested at the factory. If there are any problems, please let us know.

CONTROL HANDLE ASSEMBLY

The steering control handles are not attached to the trowel's two lower handles at the time of shipment. To attach the steering control handles to the two lower handle assemblies, perform the following:

1. Remove the bolts from the plastic bag tied to the control towers.
2. Remove all protective wrapping and straps from the control handles.
3. Slip the top (loose) piece into the base of the corresponding handle, making sure to line up the holes.
4. Install the bolt through the lined up holes and tighten the acorn nut onto the threaded end.

NOTICE

Some models are equipped with adjustable height handles. Adjust the height by placing the bolt through the set of holes that corresponds to the most comfortable height.

5. Pay close attention to any wires that may be inside the control handles. **DO NOT** pinch or cut any wires during installation.
6. Inside the plastic bag of parts are two knobs for the pitch control tower cranks. Install these two knobs onto the tower crank levers.

SEAT ASSEMBLY

The seat is not installed on the trowel for shipping purposes. To attach the seat perform the following:

1. Remove the seat from the protective wrapping.
2. Insert the studs on the bottom of the seat through the holes in the mounting plate.
3. Install and tighten the provided nuts.
4. Connect the engine stop switch (seat) cable to the mating plug as shown in Figure 8.

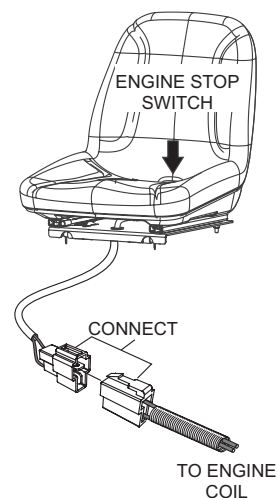

Figure 8. Engine Stop Switch (Seat)

BATTERY SETUP

This trowel was shipped with a wet charged battery. This battery may need to be charged for a brief period of time as per the manufacturer instructions.

CAUTION

Use all safety precautions specified by the battery manufacturer when working with the battery.

To install the battery onto the trowel, make sure that the battery is well seated in the battery box. The positive cable, normally red, is associated with the “+” symbol on the battery. The negative cable, normally black, is associated with the “-” symbol on the battery. See Figure 9. Connect the positive cable to the positive terminal on the battery first, then connect the negative cable to the negative terminal. Close the plastic battery box cover and secure the battery box.

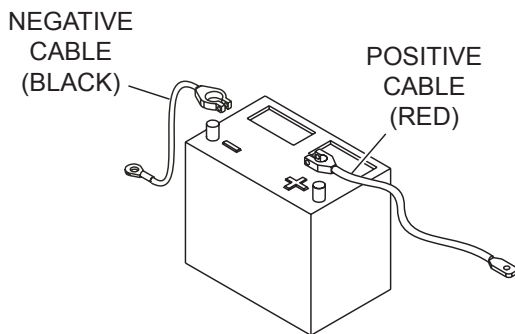

Figure 9. Battery Cable Orientation

This section is intended to assist the operator with the initial inspection of the trowel. It is extremely important that this section be read carefully before attempting to use the trowel in the field.

DO NOT use your trowel until this section is thoroughly understood.

CAUTION

Failure to understand the operation of the trowel could result in severe damage to the trowel or personal injury.

See Figure 5 and Figure 6 for the location of any control or indicator referenced in this manual.

ENGINE OIL LEVEL

1. Pull the engine oil dipstick from its holder.
2. Determine if engine oil is low (Figure 10). Add the correct amount of engine oil to bring the oil level to a normal safe level. See Table 7.

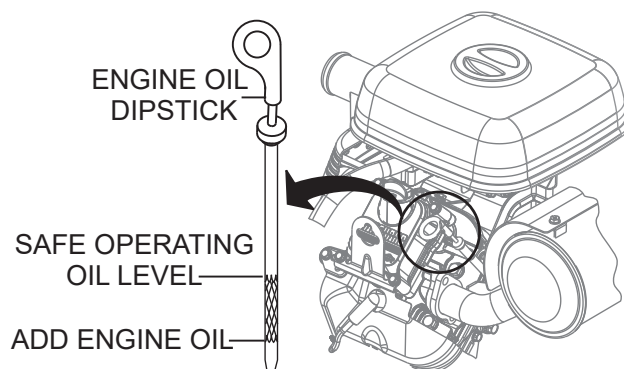
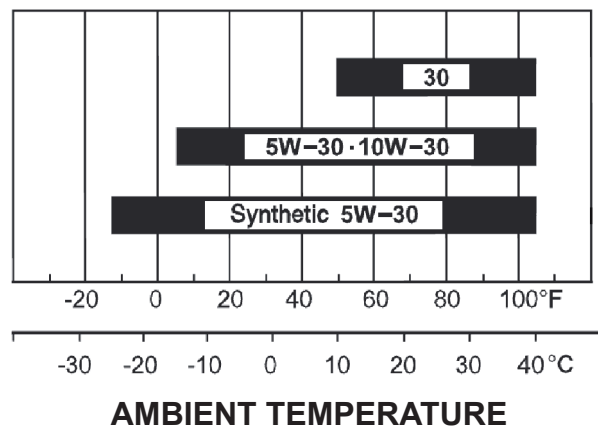

Figure 10. Engine Oil Dipstick

Table 7. Recommended Viscosity Grades



GEARBOX OIL LEVEL

1. Check the gearbox oil level in both gearboxes by viewing the sight glass at the rear of the gearbox. See Figure 11.

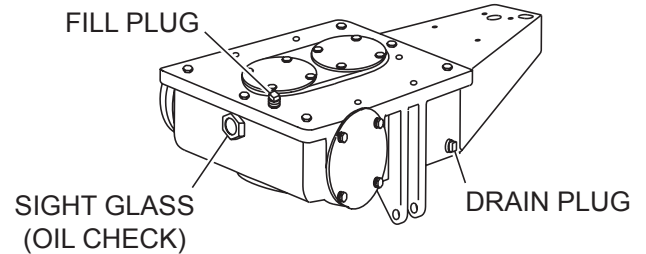

Figure 11. Gearbox Oil Plugs/Sight Glass

2. The oil level of the gearbox should be at the halfway point of the sight glass (Figure 11). The gearbox oil capacity is 1 gallon (3.79 liters). If additional oil is required, unscrew the oil fill plug located on top of the gearbox, and refill with ISO 220 A GMA GR 5 EP oil.

FUEL

Determine if engine fuel is low (Figure 12). If the fuel level is low, remove the fuel filler cap and fill with gasoline with a minimum octane rating of 87.

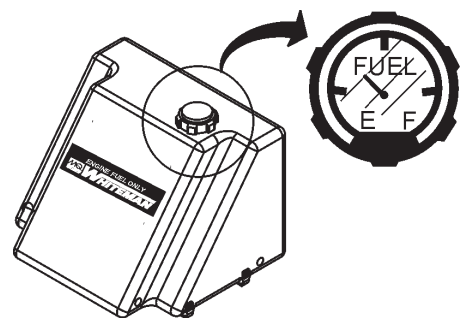

Figure 12. Fuel Gauge

DANGER

Handle fuel safely. Motor fuels are highly flammable and can be dangerous if mishandled. **NEVER** smoke while refueling. **NEVER** attempt to refuel the ride-on trowel while the engine is hot or running.

CAUTION

Never store the ride-on trowel with fuel in the tank for an extended period of time. Always clean up spilled fuel immediately.

STARTING THE ENGINE

1. Place one foot on the trowel's platform, grab any part of the frame, lift yourself onto the trowel, and sit down in the operator's seat.

NOTICE

This trowel is equipped with a safety stop switch that will not allow the engine to start unless an operator is sitting in the operator's seat. The weight of the operator depresses an electrical switch, which allows the engine to start.

WARNING

NEVER disable or disconnect the safety stop switch. It is provided for the operator's safety, and injury may result if it is disabled, disconnected, or improperly maintained.

NOTICE

Using the safety stop switch to stop the engine after every use will verify that the switch is working properly. Remember to turn the key to the **OFF** position after stopping the machine. Not doing so may drain the battery.

2. The right foot pedal (Figure 13) controls blade and engine speed. The position of the foot pedal determines the blade speed. Slow blade speed is obtained by slightly depressing the pedal. Maximum blade speed is obtained by fully depressing the pedal.

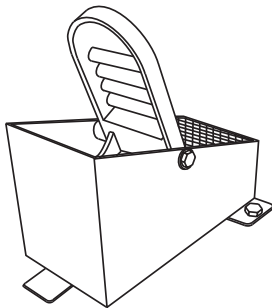

Figure 13. Blade Speed Control Foot Pedal

3. If starting a cold engine, pull the choke knob (Figure 14) upward to the **CLOSED** position.

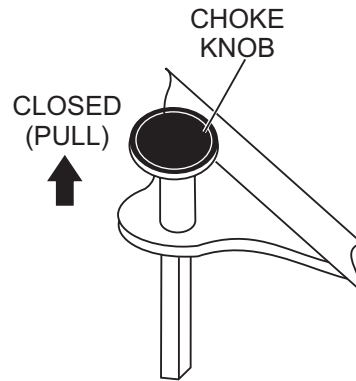

Figure 14. Choke Knob (Closed Position)

4. Insert the ignition key (Figure 15) into the ignition switch.

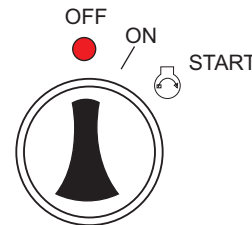

Figure 15. Ignition Switch

5. Turn the ignition key clockwise to the **ON** position. The Aux1, Aux 2, Coolant Temp and Oil Indicator lamps will light for 10 seconds (Figure 16). The Charge Indicator lamp will remain lit until the engine starts.

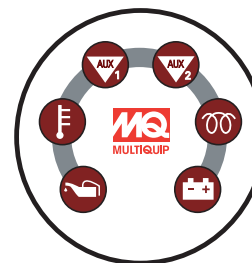

Figure 16. Indicator Lights

NOTICE

The **oil** and **charge** indicator lights come on when the ignition switch is in the **ON** position, and the engine is **NOT** running.

6. Keeping your foot **OFF** the right foot pedal, turn the ignition key fully clockwise and listen for the engine to start. Once the engine has started, release the ignition key. The throttle speed defaults to idle. Let the engine warm for a few minutes.

NOTICE

The throttle will default to full speed when the right foot pedal is depressed and operator presence is detected.

7. Once the engine has been started and warmed, return the choke knob (Figure 17) to the **OPEN** position.

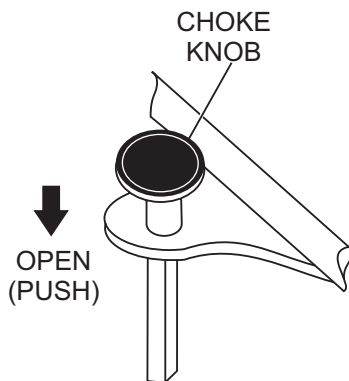

Figure 17. Choke Knob (Open Position)

8. If the engine fails to start in this manner, consult the engine owner's manual supplied with the trowel.
9. Test the safety stop switch by standing up briefly. The switch under the seat should cause the engine to stop. If the switch fails to shut down the engine, turn off the engine with the key switch and fix the safety stop switch. See the **Troubleshooting** tables for possible problems.
10. Repeat this section a few times to get fully acquainted with the engine starting procedure.

STEERING

Two control levers located in front of the operator's seat provide directional control for the trowel. Table 8 illustrates the various directional positions of the joysticks and their effect on the ride-on trowel.

NOTICE

All directional references with respect to the steering control levers are from the operator's seat position.

1. Push both the left and right control levers forward. See Figure 18.

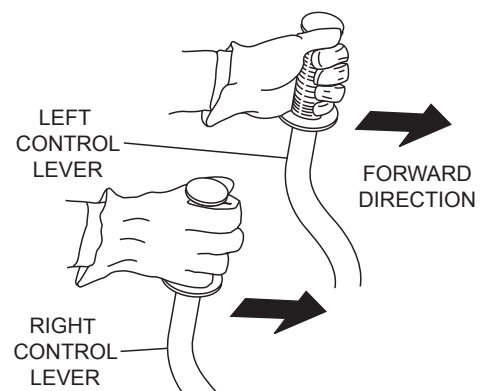

Figure 18. Left and Right Control Levers

2. With your right foot, quickly depress the right foot pedal halfway. Notice that the ride-on power trowel begins to move in a forward direction. Return both joystick controls to their neutral position to stop forward movement, then remove your right foot from the right foot pedal.
3. Practice holding the machine in one place as you increase blade speed. When about 75% of maximum blade speed has been reached, the blade will be moving at proper finishing speed. The machine may be difficult to keep in one place. Trying to keep the ride-on trowel stationary is good practice for operation.
4. Practice maneuvering the ride-on trowel using the information listed in Table 8. Try to practice controlled motions as if you were finishing a slab of concrete. Practice edging and covering a large area.
5. Try adjusting the pitch of the blades. This can be done with the ride-on trowel stopped or while the trowel is moving, whichever feels comfortable. Test the operation of optional equipment like retardant spray and lights if equipped.

- Push both the left and right joysticks backward and repeat steps 3 through 6 while substituting the word *reverse* for *forward*.

Table 8. Control Lever Directional Positioning		
Control Lever	Direction	Results
Left	Move Control Lever Forward	Causes the ride-on trowel to move forward and to the right.
Left	Move Control Lever Backward	Causes the ride-on trowel to move backward and to the left.
Right	Move Control Lever Forward	Causes the ride-on trowel to move forward and to the left.
Right	Move Control Lever Backward	Causes the ride-on trowel to move backward and to the right.
Left and Right	Move Both Control Levers Forward	Causes the ride-on trowel to move forward in a straight line.
Left and Right	Move Both Control Levers Backward	Causes the ride-on trowel to move backward in a straight line.
Left and Right	Move Both Control Levers to the Right	Causes the ride-on trowel to move to the right.
Left and Right	Move Both Control Levers to the Left	Causes the ride-on trowel to move to the left.

NOTICE

Trowel arms can be damaged by rough handling or by striking exposed plumbing or forms while in operation. **ALWAYS** look out for objects which might cause damage to the trowel arms.

Blade Pitch

Sometimes it may be necessary to match blade pitch between the two sets of blades. There are some signs that this may be necessary. For example, the differences in pitch could cause a noticeable difference in finish quality between the two sets of blades. Or, the difference in blade pitch could make the machine difficult to control. This is due to the surface area in contact with the concrete—the blade set with the greater contact area tends to stick to the concrete more.

Matching Blade Pitch for Both Sets of Blades

Trowels equipped with Twin Pitch™ controls may need to have blade pitch synchronized between the two sets of blades. Synchronization of the blades is easily accomplished by performing the following:

- Lift the pitch adjustment handle (Figure 19) on either side of the trowel. Once lifted, that side is now disconnected from the Twin Pitch™ system.

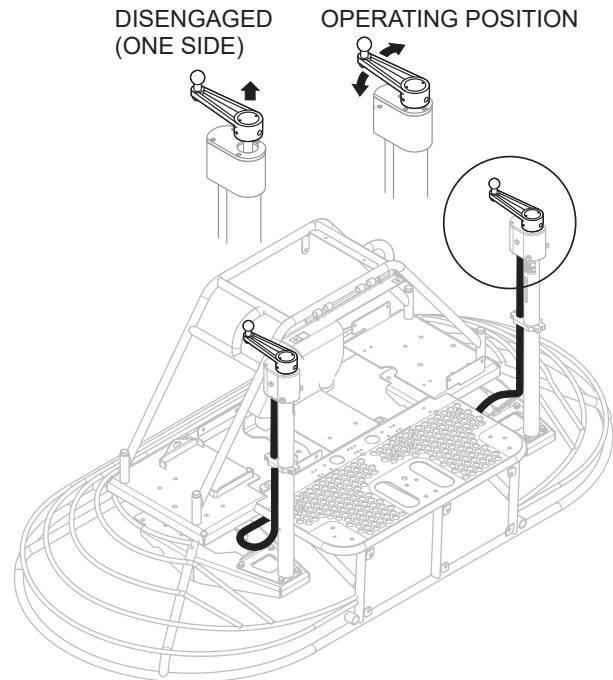

Figure 19. Pitch Towers

- Adjust to match the opposite side.
- Once adjusted, lower the handle to the Twin Pitch™ operating position.

Table 9. Engine Maintenance Schedule						
DESCRIPTION (3)	OPERATION	BEFORE EACH USE	FIRST MONTH OR 20 HRS.	EVERY 6 MONTHS OR 100 HRS.	EVERY YEAR OR 300 HRS.	EVERY 2 YEARS OR 500 HRS.
Engine Oil	Check	X				
	Change		X	X		
Engine Oil Filter	Replace			X		
Air Cleaner	Check	X				
	Clean			X (1)		
	Change					X (*)
Spark Plugs	Check/Adjust			X		
	Replace				X	
Spark Arrester	Clean			X		
Fuel Filter	Replace				X (2)	
Fuel Tube	Check	Every 2 years (replace if necessary) (2)				

* Replace the paper filter element only.

(1) Service more frequently when used in **DUSTY** areas.

(2) These items should be serviced by your service dealer, unless you have the proper tools and are mechanically proficient. Refer to the Briggs & Stratton Shop Manual for service procedures.

(3) For commercial use, log hours of operation to determine proper maintenance intervals.

Table 10. Trowel Maintenance Schedule						
Check Item	OPERATION	DAILY	Periodic Maintenance Interval			
			Every 25 Hrs	Every 50 Hrs	Every 100–125 Hrs	Every 500 Hrs
Relube arms, thrust collars, and cross shaft.	Grease	X				
Remove, clean, reinstall and relube arms and thrust collar.	Clean				X	
Check and replace, if necessary, arm bushings and thrust collar bushings.	Check			X		
Check blades for excessive wear or damage and replace if necessary.	Check	X				
Adjust blade speed if necessary.	Check					X
Gearbox lubricant	Replace				1st time	X
Drive belt	Check		X			
Fasteners	Check	X				

When performing any maintenance on the trowel or engine, follow all safety messages and rules for safe operation stated at the beginning of this manual.

At the front of this manual there is a **Daily Pre-Operation Checklist**. Make copies of this checklist and use it on a daily basis.

WARNING

 Accidental starts can cause severe injury or death.

 **ALWAYS** place the ON/OFF switch in the OFF position.

 Disconnect and ground spark plug leads and disconnect the negative battery cable from the battery before servicing.

WARNING

 Some maintenance operations may require the engine to be run. Ensure that the maintenance area is well ventilated. Exhaust contains poisonous carbon monoxide gas that can cause unconsciousness and may result in **DEATH**

CAUTION

 **ALWAYS** allow the engine to cool before servicing. **NEVER** attempt any maintenance work on a hot engine.

Air Cleaner

Thoroughly remove dirt and oil from the engine and control area. Clean or replace the air cleaner elements as necessary. Check and retighten all fasteners as necessary.

1. Unscrew the latch locking knob (Figure 20) located on top of the air cleaner cover, and remove the cover.

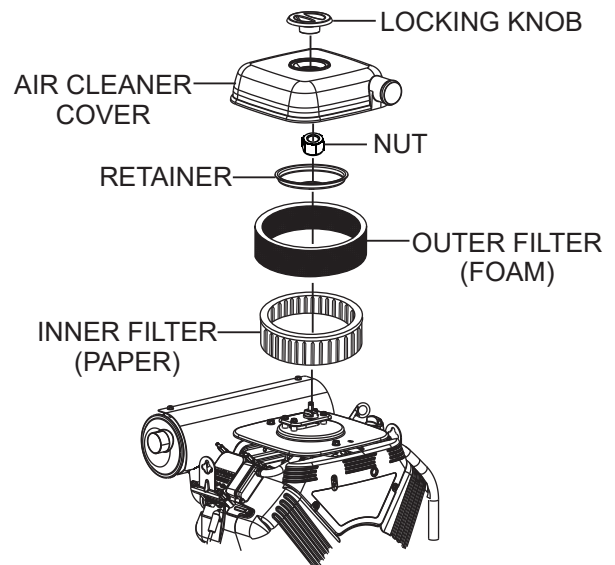

Figure 20. Air Filter Components

2. Remove the nut, outer (foam) filter, and inner (paper) filter.
3. Inspect both air filter elements, and replace them if necessary.

Air Cleaner Cleaning

CAUTION



Wear protective equipment such as approved safety glasses or face shields and dust masks or respirators when cleaning air filters with compressed air.

1. To clean the paper air filter (Figure 21), tap the filter element several times on a hard surface to remove dirt, or blow compressed air not exceeding 30 psi (207 kPa, 2.1 kgf/cm²) through the filter element from the inside out.

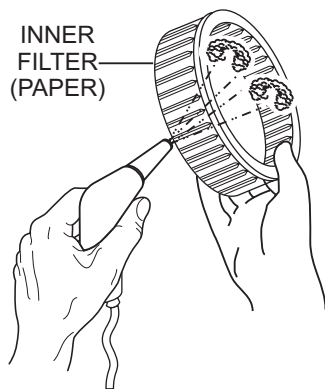

Figure 21. Cleaning Inner Paper Filter

2. **NEVER** try to brush off dirt; brushing will force dirt into the fibers. If the paper element is excessively dirty, replace the element.
3. Clean the foam air filter element in warm, soapy water, rinse, and allow to dry thoroughly. Or clean with a nonflammable solvent and allow to dry. **NEVER** pour any type of oil into the foam element.
4. Wipe dirt from the inside of the air cleaner body and cover using a moist cloth. Be careful to not let any dirt or debris enter the air chamber that leads to the carburetor.
5. Place the foam air filter element back onto the paper air filter element. Reinstall the air cleaner and cover. Using the locking knob, securely lock the air cleaner cover.

CAUTION

Operating the engine with a blocked grass screen, dirty or plugged cooling fins, and/or cooling shrouds removed will cause engine damage due to overheating.

Changing Engine Oil (100 Hours)

NOTICE

Always drain the engine oil while the oil is **warm**.

1. Remove the oil drain bolt and sealing washer and allow the oil to drain into a suitable container (Figure 22).

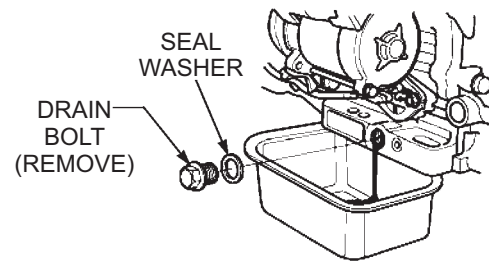

Figure 22. Draining Engine Oil

2. Reinstall the drain bolt with sealing washer and tighten securely.
3. Replace engine oil with the recommended oil type listed in Table 3. For engine oil capacity, see Table 3. **DO NOT** overfill.

Oil Filter (100 Hours)

Replace the engine oil filter (Figure 23) every 100 hours. Be sure to coat the seal of the new oil filter with clean engine oil.

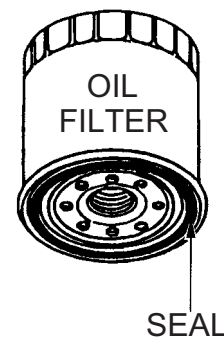

Figure 23. Oil Filter

Fuel Filter (200 Hours)

Replace the fuel filter (Figure 24) every 200 hours.

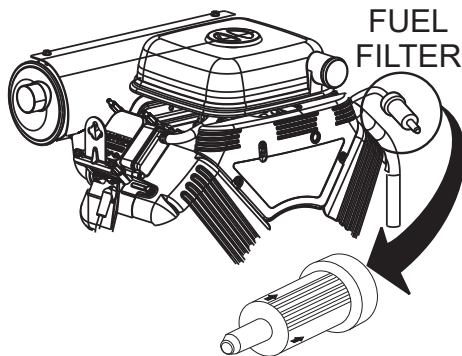

Figure 24. Fuel Filter Location

Spark Plugs

1. Make sure the engine is cool before servicing the spark plugs.
2. Disconnect the spark plug caps. Check for dirt and remove any dirt from around the spark plug area.
3. Remove the spark plugs with a 5/8-inch spark plug wrench.
4. If the spark plugs are damaged, the sealing washer is in poor condition, or the electrode is worn, replace the spark plugs.
5. Measure the spark plug electrode gap (Figure 25) with a wire-type feeler gauge. If needed, adjust the gap to .030 in. (0.76 mm) by carefully bending the side electrode.

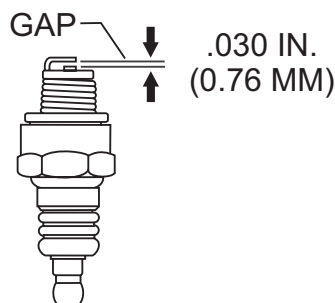

Figure 25. Spark Plug Gap Adjustment

6. Install the spark plug carefully, by hand, to avoid cross-threading.
7. After the spark plug is seated, tighten with a 5/8-inch spark plug wrench to compress the sealing washer.

8. When installing a new spark plug, tighten 1/2 turn after the spark plug seats to compress the washer.
9. When reinstalling the original spark plug, tighten 1/8–1/4 turn after the spark plug seats to compress the washer.
10. Reattach the spark plug caps.

ENGINE TUNE-UP ENGINE

See your engine manual for specific information on tuning up your engine, checking and gapping the spark plugs, etc.

NOTICE

See the engine manual supplied with your machine for appropriate engine maintenance schedule and troubleshooting guide for problems.

LONG TERM STORAGE

- Drain the fuel tank completely, or add STA-BIL® to the fuel.
- Remove the spark plug and pour a few drops of motor oil into the cylinder. Crank the engine 3 to 4 times so that oil reaches all internal parts.
- Clean the exterior with a cloth soaked in clean oil.
- Remove the battery.
- Cover the unit with a plastic sheet and store it in a moisture- and dust-free location out of direct sunlight.

CAUTION

NEVER store the ride-on trowel with fuel in the tank for an extended period of time. Always clean up spilled fuel immediately.

TROWEL LUBRICATION

Regular lubrication is required to maintain your trowel in optimal working condition. Schedule maintenance lubrication according to Table 11 below.

Table 11. Trowel Lubrication Schedule		
Location	# of Shots	Interval
Spiders	1 to 1½	Every day
Thrust collars	1	Every day
Pillow blocks	1	Every day
Pitch levers	1	Once a month
Pitch towers	1	Every 6 months

Spiders (Daily)

Perform the following lubrication procedure after **every 8 hours of use**.

1. Locate one of the Zerk grease fittings on either spider assembly (Figure 26). Remove the Zerk fitting cap and set it aside.

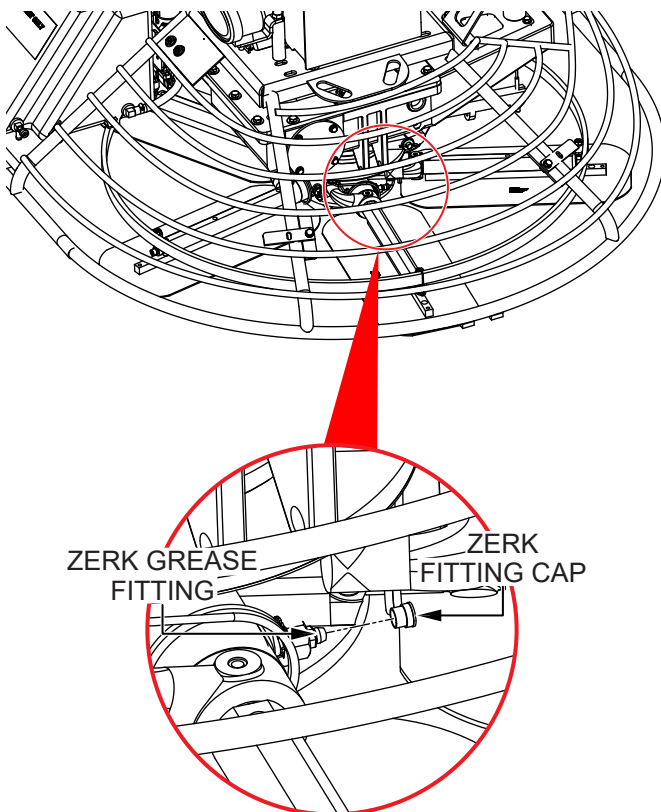

Figure 26. Spider Lubrication

2. Wipe the Zerk grease fitting clean to prevent abrasive material from entering the fitting during lubrication.
3. Lubricate the Zerk grease fitting with 1–1½ shots of multipurpose grade grease. Replace the Zerk grease fitting cap when finished.
4. Repeat steps 1–3 for the remaining grease fittings on both spider assemblies.

Thrust Collars (Daily)

Perform the following lubrication procedure after **every 8 hours of use**.

1. Locate the Zerk grease fitting on either thrust collar (Figure 27). Remove the Zerk grease fitting cap and set it aside.

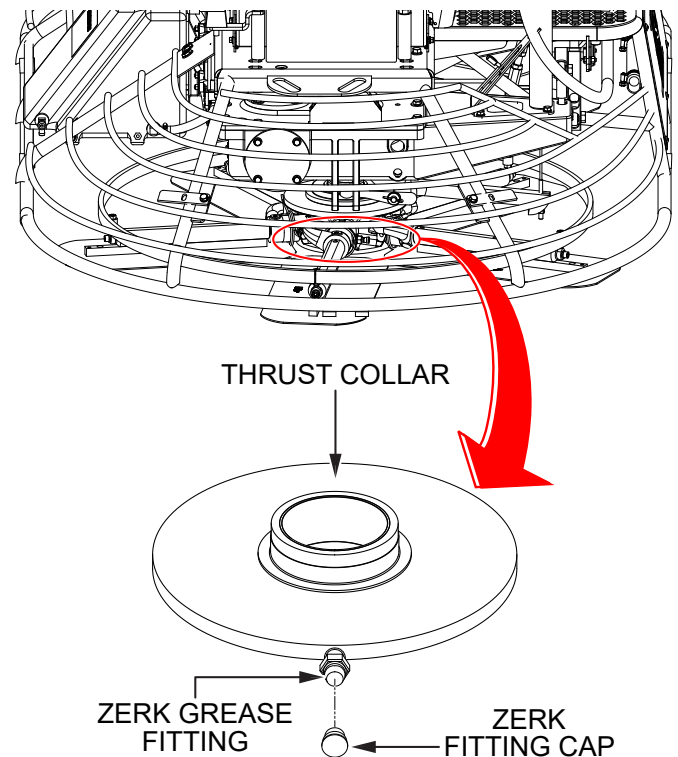

Figure 27. Thrust Collar Lubrication

2. Wipe the Zerk grease fitting clean to prevent abrasive material from entering the fitting during lubrication.
3. Lubricate the Zerk grease fitting with one shot of multipurpose grade grease. Replace the Zerk grease fitting cap when finished.
4. Repeat steps 1–3 for the grease fitting on the remaining thrust collar.

Pillow Block Bearings (Daily)

Perform the following lubrication procedure after **every 8 hours of use**.

1. Locate the grease port plate (Figure 28) at the rear of the trowel, just behind the fuel tank. These two Zerk grease fittings lubricate the pillow block bearings.

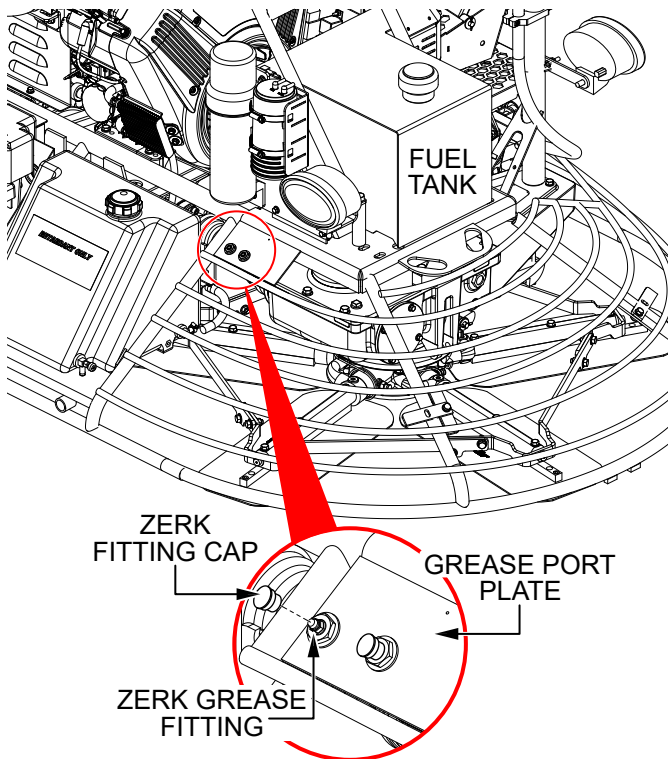

Figure 28. Pillow Block Bearing Lubrication

2. Remove the Zerk grease fitting caps and set them aside.
3. Wipe the Zerk grease fittings clean to prevent abrasive material from entering the fittings during lubrication.
4. Lubricate each Zerk grease fitting with one shot of multipurpose grade grease. Replace the Zerk grease fitting caps when finished.

Pitch Adjustment Levers (Monthly)

Perform the following lubrication procedure **once a month**.

1. Locate the Zerk grease fitting next to the knob on either pitch adjustment lever (Figure 29). Remove the Zerk grease fitting cap and set it aside.

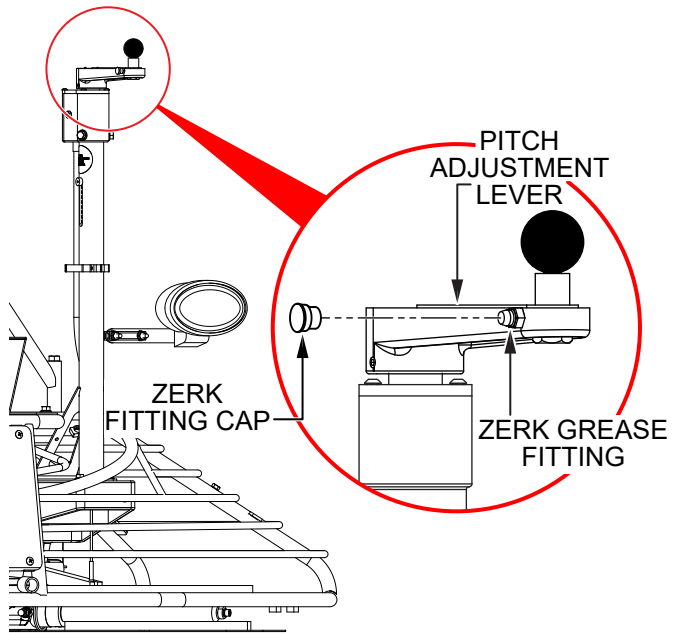

Figure 29. Pitch Adjustment Lever Lubrication

2. Wipe the Zerk grease fitting clean to prevent abrasive material from entering the fitting during lubrication.
3. Lubricate the Zerk grease fitting with one shot of multipurpose grade grease. Replace the Zerk grease fitting cap when finished.
4. Repeat steps 1–3 for the grease fitting on the remaining pitch adjustment lever.

Pitch Tower (Every 6 Months)

Perform the following lubrication procedure **once every 6 months**.

1. Locate the Zerk grease fitting just below the pitch adjustment lever on either pitch tower (Figure 30). Remove the Zerk grease fitting cap and set it aside.

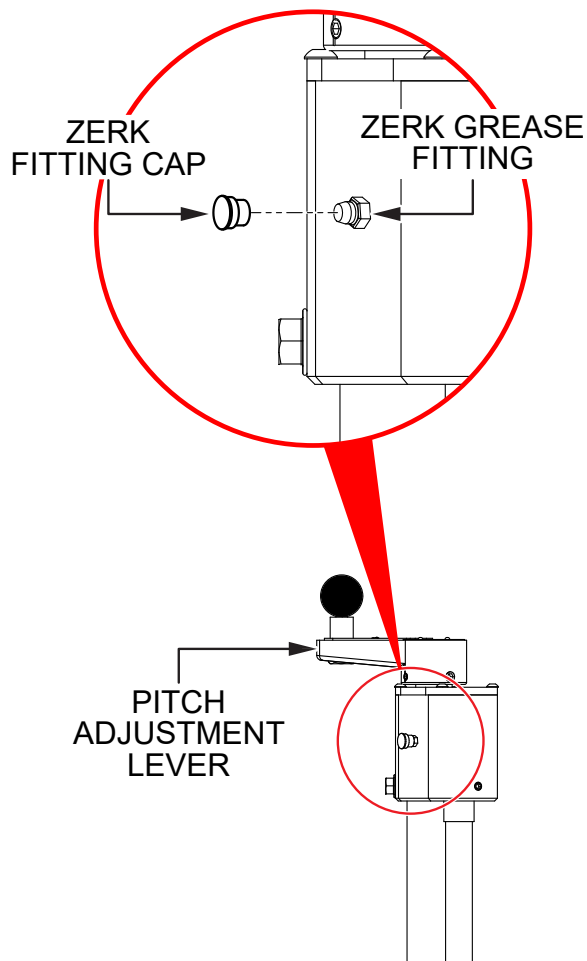

Figure 30. Pitch Tower Lubrication

2. Wipe the Zerk grease fitting clean to prevent abrasive material from entering the fitting during lubrication.
3. Lubricate the Zerk grease fitting with one shot of multipurpose grade grease. Replace the Zerk grease fitting cap when finished.
4. Repeat steps 1–3 for the grease fitting on the remaining pitch tower.

CHECKING THE DRIVE BELT

The drive belt needs to be changed as soon as it begins to show signs of wear. **NEVER** reuse a belt under any circumstances. Indications of excessive belt wear are fraying, squealing when in use, belts that emit smoke or a burning rubber smell when in use.

To gain access to the drive belt (Figure 31), remove the drive belt guard cover, then visually inspect the drive belt for signs of damage or excessive wear. If the drive belt is worn or damaged, replace the drive belt.

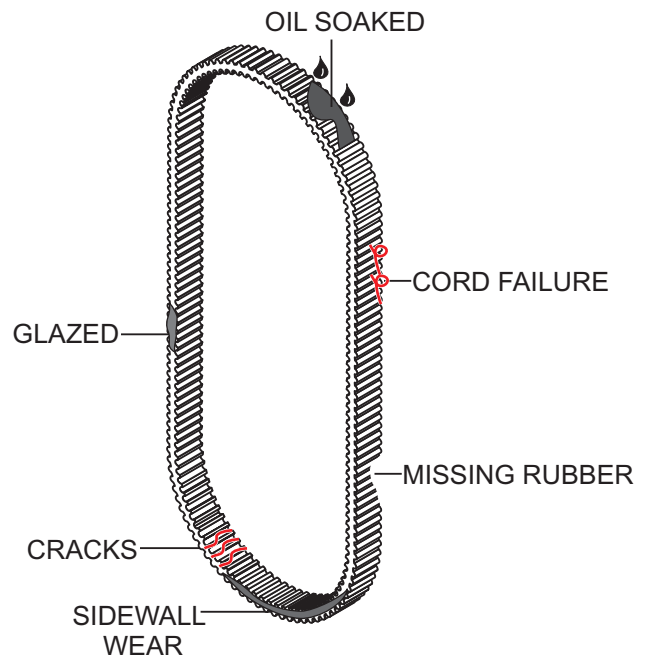

Figure 31. Drive Belt Inspection

WARNING



NEVER attempt to insert hands or tools into the drive belt area while the engine is running and the safety guard has been removed. Keep fingers, hands, hair and clothing away from all moving parts to prevent bodily injury.

WARNING



DO NOT remove the drive belt guard cover until the muffler has cooled. Allow the entire trowel to cool down before performing this procedure.

BELT MEASUREMENT

Long life can be expected for this drive assembly as long as the drive belt is kept properly aligned.

The clutch will not shift correctly if the drive belt width is less than 1.14 inch. Measure the CVT drive belt (Figure 32) every 100 hours of use to make sure it is within the specified tolerance.

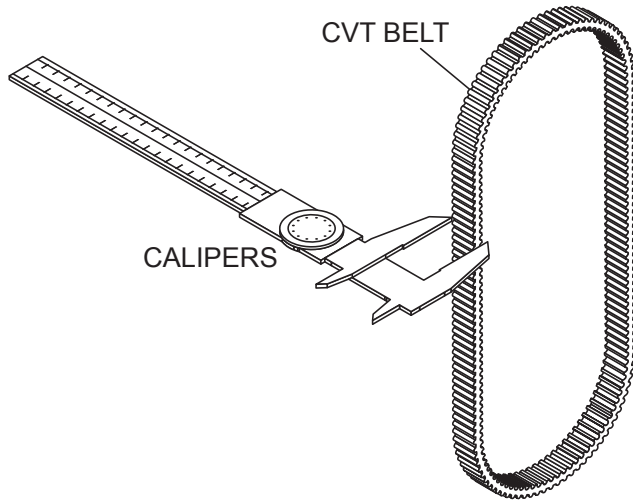

Figure 32. Belt Measurement

REMOVING THE DRIVE BELT

1. Remove the retaining screws (4) that secure the drive belt guard (Figure 33) to the trowel frame.

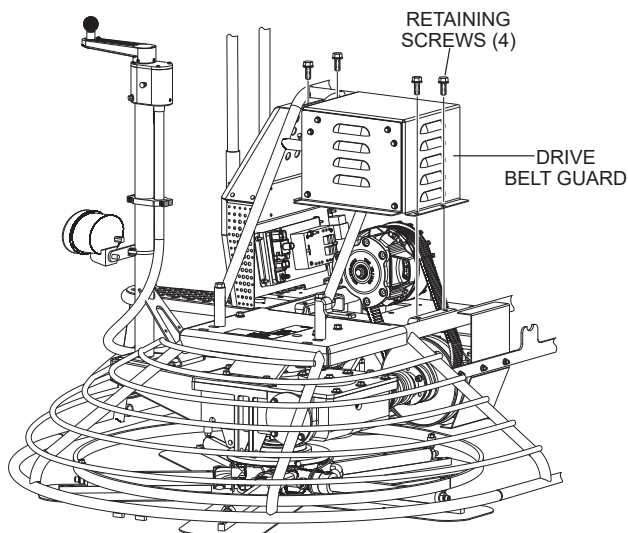

Figure 33. Drive Belt Guard Removal

2. Disconnect the left-side CV axle from the left-side gearbox and the lower drive pulley coupler. See Figure 34.

NOTICE

Note that the 3 bolts securing the CV axle to the coupler are shorter than those securing the CV axle to the gearbox. Remember bolt orientation for reassembly.

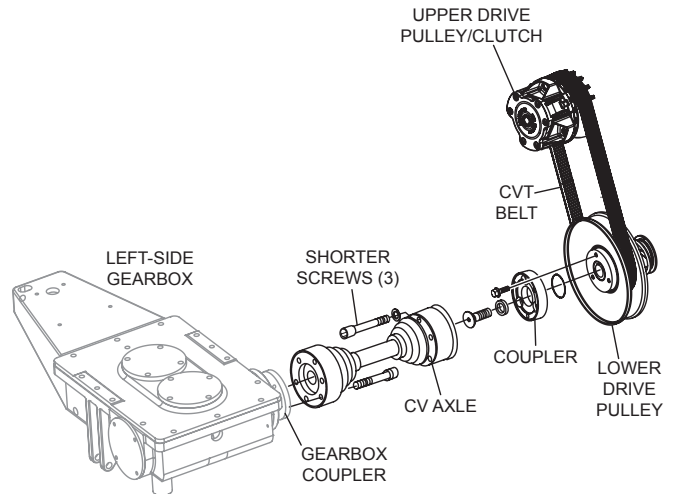

Figure 34. Remove Left-Side CV Axle

3. If the belt is not being reused (recommended), cut the drive belt. Ensure all belt remnants are removed from the pulleys.

INSTALLING THE DRIVE BELT

1. Place the new CVT belt over the lower pulley (Figure 35). Squeeze and pull the belt upwards and towards the rear of the trowel. This will spread open the faces of the lower drive pulley.

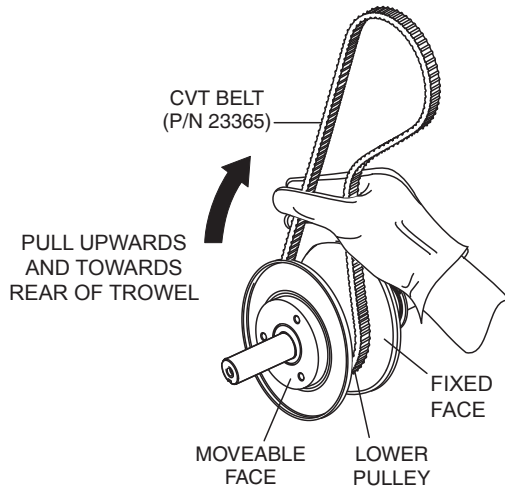

Figure 35. Holding Lower Pulley Open

2. Place the free end of the CVT belt (Figure 36) into the upper pulley grooves.

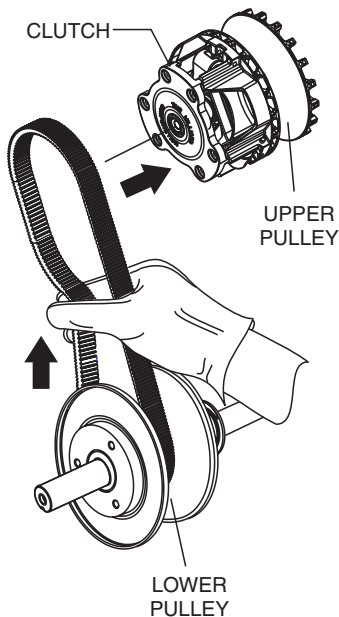

Figure 36. Upper Pulley Belt Installation

3. Apply a thin coat of RVT silicone to the mating surfaces of the CV-joint (Figure 37) and left-side gearbox coupler.

APPLY SILICONE TO CV-JOINT MATING SURFACES



Figure 37. Applying RVT Silicone

4. Reconnect the CV-joint to the left-side gearbox coupler.
5. Re-install drive belt guard onto frame. Secure with retaining screws (4).

BLADE PITCH ADJUSTMENT PROCEDURE

Maintenance adjustment of blade pitch is made by adjusting a bolt (Figure 38) on the arm of the trowel blade finger. This bolt is the contact point of the trowel arm to the lower wear plate on the thrust collar. The goal of adjustment is to promote consistent blade pitch and finishing quality.

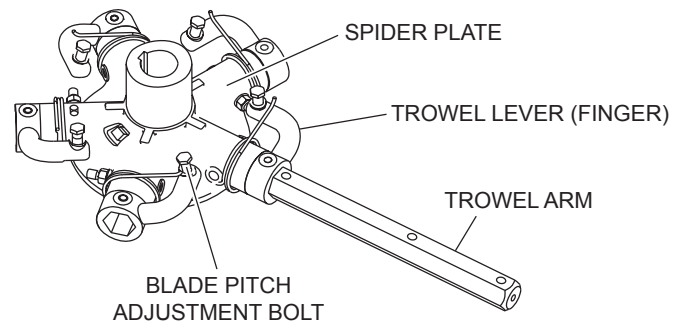

Figure 38. Blade Pitch Adjustment Bolt

Look for the following indications if blades are wearing unevenly. If so, adjustment may be necessary.

- Are the blades wearing unevenly? Is one blade completely worn out while the others look new?
- Does the machine have a perceptible rolling or bouncing motion when in use?
- Do the guard rings rock up and down while the machine is running?
- Do the pitch control towers rock back and forth?

The easiest and most consistent way to make adjustments on the trowel arm fingers is to use the Trowel Arm Adjustment Fixture (P/N 9177). It comes with all the hardware necessary to properly accomplish this maintenance, and instructions on how to utilize this tool.

If a trowel arm adjustment fixture is not available and immediate adjustment is necessary, temporary field adjustment can be made, if you can see or feel which blade is pulling harder, by adjusting the bolt that corresponds to that blade.

A better way to determine which blades need adjustment is to place the machine on a known FLAT surface (e.g. steel plate) and pitch the blades as flat as possible. Look at the adjustment bolts. They should all barely make contact with the lower wear plate on the spider. If you can see that one of them is not making contact, some adjustment will be necessary.

Adjust the “high” bolts down to the level of the one that is not touching, or adjust the “low” bolt up to the level of the higher ones. If possible, adjust the low bolt up to the level of the rest of the bolts. This is the fastest way, but may not always work. Verify after adjustment that the blades pitch correctly.

Blades that are incorrectly adjusted often will not be able to pitch flat. This can occur if the adjusting bolts are raised too high. Conversely, adjusting bolts that are too low will not allow the blades to be pitched high enough for finishing operations.

If, after blade pitch adjustments have been made, the machine is still finishing poorly, blades, trowel arms, and trowel arm bushings should be checked for adjustment, wear, or damage. See the following sections.

CHANGING BLADES

It is recommended that **ALL** the blades on the entire machine are changed at the same time. If only one or some of the blades are changed, the machine will not finish concrete consistently and the machine may wobble or bounce.

1. Place the machine on a flat, level surface. Adjust the blade pitch control to make the blades as flat as possible. Note the blade orientation on the trowel arm. This is important for ride-on trowels as the two sets of blades counter-rotate. Lift the machine up, placing blocks under the main guard ring to support it.

2. Remove the bolts and lock washers on the trowel arm, then remove the blade.
3. Scrape all concrete and debris from the trowel arm. This is important to properly seat the new blade.
4. Install the new blade, maintaining the proper orientation for direction of rotation.
5. Reinstall the bolts and lock washers.
6. Repeat steps 2–5 for all remaining blades.

CLEAN-UP

Never allow concrete to harden on the power trowel. Immediately after use, wash any concrete off the trowel with water. Be careful to not spray a hot engine or muffler. An old paint brush or broom may help loosen any concrete that has started to harden.

TROWEL ARM ADJUSTMENT

NOTICE

The following procedure should be performed to adjust trowel arms when it becomes apparent that the trowel is finishing poorly or in need of routine maintenance.

A level, clean area to test the trowel prior to and after is essential. Any unlevel spots in the floor or debris under the trowel blades will give an incorrect perception of adjustment. Ideally, a 5' x 5', 3/4 inch thick, flat, steel plate should be used for testing.

Some indications of poor concrete finishing are incorrect trowel arm alignment, worn spider bushings, or bent trowel arms:

Does your trowel exhibit the following?

- Are the blades wearing unevenly? Is one blade completely worn out while the others look new?
- Do the guard rings rock up and down while the machine is running?
- Does the machine have a perceptible rolling or bouncing motion when in use?

1. To determine which blades need adjustment, place the trowel in the test area (3/4 inch thick plate) and look for the following conditions:
2. Pitch the blades as flat as possible. The adjustment bolts should all barely make contact with the lower wear plate on the spider. If one is not making contact, adjustment will be necessary (Figure 39).

Figure 39 illustrates incorrect alignment, worn spider bushings, or bent trowel arms. Check that the adjustment bolt is barely touching (0.10" max. clearance) the lower wear plate. All alignment bolts should be spaced the same distance from the lower wear plate.

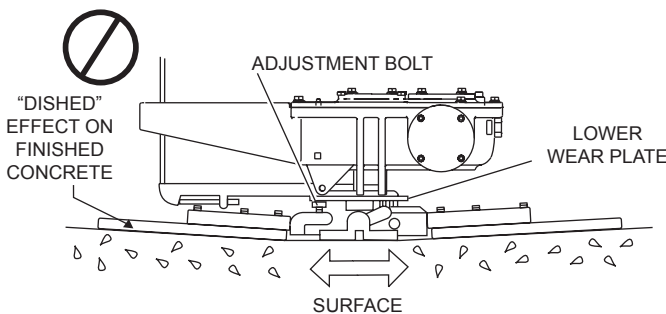

Figure 39. Incorrect Spider Plate Alignment

Figure 40 illustrates the correct alignment for a spider plate (as shipped from the factory).

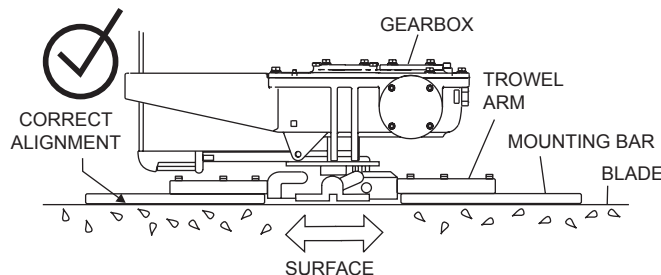

Figure 40. Correct Spider Plate Alignment

Spider Removal

Remove the spider assembly from the gearbox shaft as follows:

1. Locate the cone point square head set screws (2) and attached jam nuts (2) found on the side of the spider assembly. See Figure 41.

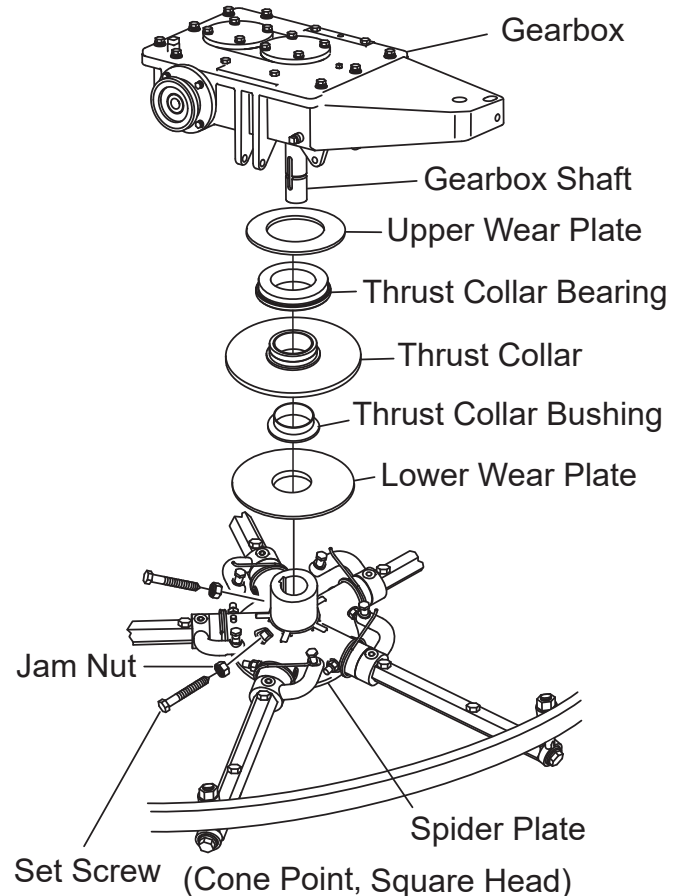

Figure 41. Spider Removal

2. Loosen the jam nuts and cone point square head set screws.
3. Carefully lift the upper trowel assembly off of the spider assembly. A slight tap with a rubber mallet may be necessary to dislodge the spider from the main shaft of the gearbox.

Trowel Blade Removal

Remove the trowel blades by removing the three hex head bolts (Figure 42) from the trowel arm. Set the blades aside.

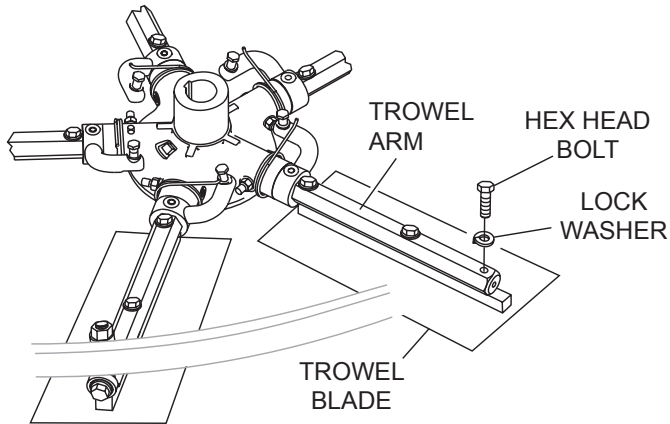

Figure 42. Trowel Blade Removal

Trowel Arm Removal

1. Remove the hardware securing the stabilizer ring to the trowel arm (Figure 43).

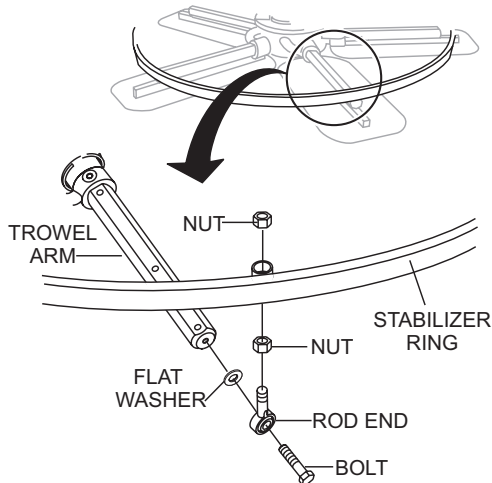

Figure 43. Stabilizer Ring

2. Each trowel arm is held in place at the spider plate (Figure 44) by a hex head bolt (zerk grease fitting) and a roll pin. Remove both the hex head bolt and the roll pin from the spider plate.

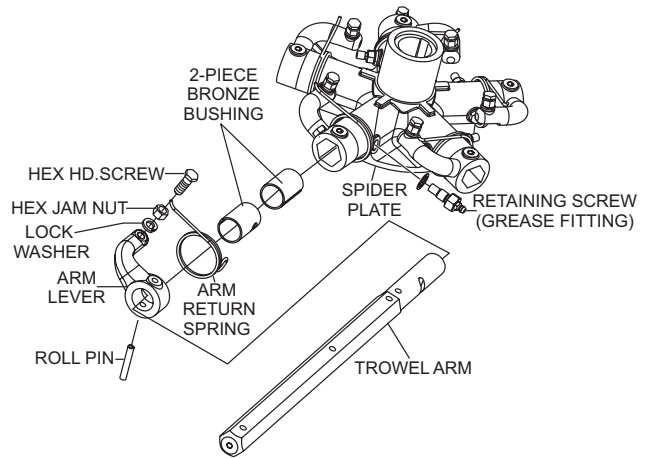

Figure 44. Remove Roll Pin and Zerk Fitting

3. Remove the trowel arm from the spider plate.
4. Should the trowel arm insert (bronze bushing) come out with the trowel arm, remove the bushing from the trowel arm and set aside in a safe place. If the bushing is retained inside the spider plate, carefully remove the bushing.
5. Examine the bronze trowel arm bushings (Figure 45), and clean if necessary. Replace bushings if out-of-round or worn.



Figure 45. Bronze Bushings

6. Wire brush any buildup of concrete from all six sides of the trowel arm. Repeat this for the remaining arms.

Checking Trowel Arm Straightness

Trowel arms can be damaged by rough handling (such as dropping the trowel on the pad), or by striking exposed plumbing, forms, or rebar while in operation. A bent trowel arm will prevent the trowel from operating with smooth, fluid rotation. If bent trowel arms are suspected, check for flatness as shown below. Refer to Figure 46.

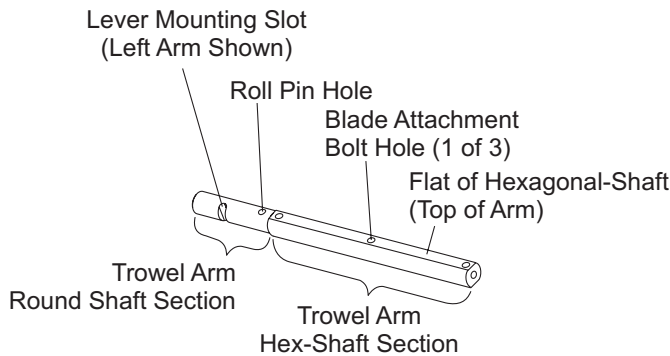

Figure 46. Trowel Arm

1. Use a thick steel plate, granite slab, or any surface which is true and flat (Figure 47), to check all six sides of each trowel arm for flatness.

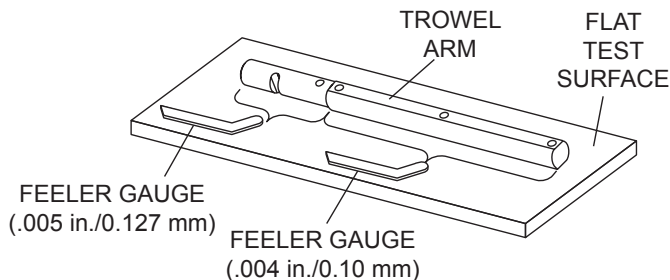

Figure 47. Checking Trowel Arm Flatness

2. Check each of the six sides of the trowel arm (hex section). A feeler gauge of .004" (0.10 mm) should not pass between the flat of the trowel arm and the test surface along its length on the test surface. See Figure 47.
3. Check the clearance between the round shaft and the test surface as one of the flat hex sections of the arm rests on the test surface. Rotate the arm to each of the flat hex sections and check the clearance of the round shaft. Use a feeler gauge of .005" (0.127 mm). Each section should have the same clearance between the round of the trowel arm shaft and the test surface.
4. If the trowel arm is found to be uneven or bent, replace the trowel arm.

Trowel Arm Adjustment Fixture

Shown in (Figure 48) is the adjustment fixture with a trowel arm inserted. As each trowel arm is locked into the fixture, the arm bolt is adjusted to where it contacts a stop on the fixture. This will consistently adjust all of the trowel arms, keeping the finisher as flat and evenly pitched as possible.

1. Locate the trowel arm adjustment fixture P/N 9177.

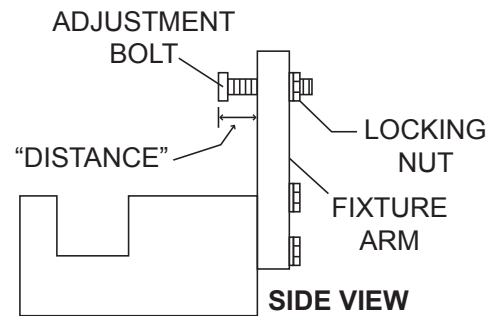

Figure 48. Trowel Arm Adjustment Tool Side View

2. Ensure the fixture arm is in the proper setting (up or down) for your trowel arm rotation as shown in Figure 49.

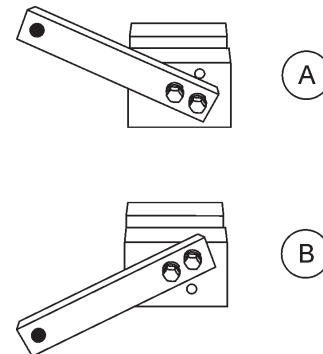

Figure 49. Trowel Arm Adjustment Setup

NOTICE

For arms with **CLOCKWISE** blade rotation, place the fixture arm in the **UP** position (Figure 49A). For arms with **COUNTERCLOCKWISE** blade rotation, place the fixture arm in the **DOWN** position (Figure 49B).

3. Unscrew the locking bolts on the adjustment tool and place the trowel arm into the fixture channel as shown in Figure 50. A thin shim may be required to cover the blade holes on the trowel arm. Make sure to align the trowel adjustment bolt with the fixture adjustment bolt.

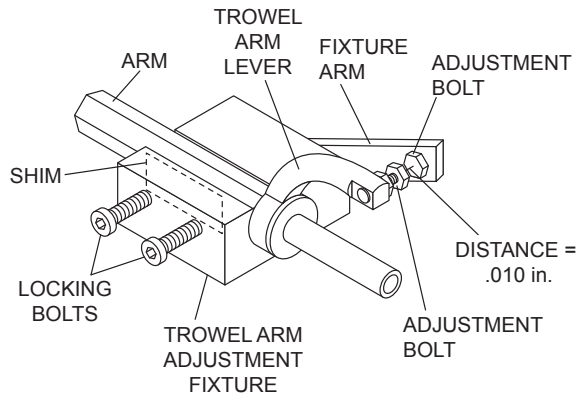

Figure 50. Trowel Arm Adjustment Fixture Components

4. Use an Allen wrench to tighten the locking bolts securing the trowel arm in place.
5. Adjust the bolt “distance” shown in Figure 50 to match one of the arms. The other arms will be adjusted to match this distance.
6. Loosen the locking nut on the trowel arm lever, then turn the trowel arm adjusting bolt until it barely touches (.010”) the fixture adjusting bolt.
7. Once the correct adjustment is made, tighten the lock nut on the trowel arm to lock it in place.
8. Loosen the locking nuts on the adjustment fixture, and remove the trowel arm.
9. Repeat steps for the remaining trowel arms.

REASSEMBLY

1. Clean and examine the upper/lower wear plates and thrust collar. Examine the entire spider assembly. Wire brush any concrete or rust buildup. If any of the spider components are found to be damaged or out-of-round, replace them.
2. Make sure that the bronze trowel arm bushing is not damaged or out-of-round. Clean the bushing if necessary. If the bronze bushing is damaged or worn, replace it.
3. Reinstall the bronze bushing onto the trowel arm.

4. Repeat steps 2–3 for each trowel arm.
5. Make sure that the spring tensioner is in the correct position to exert tension on the trowel arm.
6. Insert all trowel arms with levers into the spider plate (with bronze bushings already installed) using care to align the grease hole on the bronze bushings with the grease hole fittings on the spider plate.
7. Lock the trowel arms in place by tightening the hex head bolts with zerk grease fittings and jam nuts.
8. Reinstall the blades onto the trowel arms.
9. Reinstall the stabilizer ring onto the spider assembly.
10. Lubricate all grease points (zerk fittings) with premium Lithium 12-based grease, conforming to NLG1 Grade #2 consistency.

INSTALLING PANS ONTO FINISHER BLADES

These round discs, sometimes referred to as *pans*, attach to the trowel arms and allow early floating on wet concrete and easy movement from wet to dry areas. They are also very effective at embedding large aggregates and surface hardeners.

WARNING

ALWAYS install pans either in the work area or in an area that is next to and level with the work area. **NEVER** lift the trowel while the pans are attached.

Refer to Figure 51 when installing pans onto finisher blades.

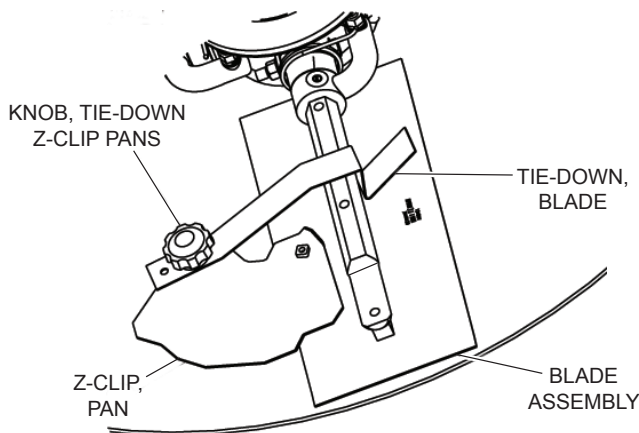

Figure 51. Z-Clip Finisher Pan Installation

1. Lift the trowel just enough to slide the pan under the blades. Lower the finisher onto the pan with the blades adjacent to the Z-clips.
2. Rotate the blades into position under the Z-clips. Ensure that the blades are rotated in the direction of travel when the machine is in operation, or use the engine to rotate the blades into position.
3. Attach the blade tie-downs to the far side of the Z-clip brackets with the tie-down knobs as shown in Figure 51.
4. Make sure the blade edges are secured under the Z-clips and the tie-downs are secured completely over the edges of the blade bar before the machine is put back into operation.

DECOMMISSIONING TROWEL/COMPONENTS

Decommissioning is a controlled process used to safely retire a piece of equipment that is no longer serviceable. If the equipment poses an unacceptable and unreparable safety risk due to wear or damage or is no longer cost effective to maintain (beyond life-cycle reliability), and is to be decommissioned (demolition and dismantlement), the following procedure must take place:

1. Drain all fluids completely. These may include oil, gasoline, hydraulic oil and antifreeze. Dispose of properly in accordance with local and governmental regulations. Never pour fluids on the ground or dump down drains or sewers.
2. Remove the battery and bring it to an appropriate facility for lead reclamation. Use safety precautions when handling batteries that contain sulfuric acid.
3. The remainder can be brought to a salvage yard or metal reclamation facility for further dismantling.

TROUBLESHOOTING (TROWEL)

Troubleshooting (Ride-On Mechanical Trowel)		
Symptom	Possible Problem	Solution
Engine running rough or not at all.	Stop switch malfunction?	Make sure that the stop switch is functioning when the operator is seated. Replace switch if necessary.
	Fuel?	Look at the fuel system. Make sure there is fuel being supplied to the engine. Check to ensure that the fuel filter is not clogged.
	Ignition?	Check to ensure that the ignition switch has power and is functioning correctly.
Safety stop switch not functioning.	Bad contacts?	Replace switch.
	Loose wire connections?	Check wiring. Replace as necessary.
	Other problems?	Consult engine manufacturer's manual.
Trowel bounces, rolls concrete, or makes uneven swirls in concrete.	Blades?	Make sure blades are in good condition, not excessively worn. Finish blades should measure no less than 2 inches (50mm) from the blade bar to the trailing edge, combo blades should measure no less than 3.5 inches (89mm). Trailing edge of blade should be straight and parallel to the blade bar.
	Pitch Adjustment?	Check that all blades are set at the same pitch angle as measured at the spider. A field adjustment tool is available for height adjustment of the trowel arms (contact Parts Department).
	Bent trowel arms?	Check the spider assembly for bent trowel arms. If one of the arms is even slightly bent, replace it immediately.
	Trowel arm bushings?	Check the trowel arm bushings for tightness. This can be done by moving the trowel arms up and down. If there is more than 1/8 inch (3.2 mm) of travel at the tip of the arm, the bushings should be replaced. All bushings should be replaced at the same time.
	Thrust collar?	Check the flatness of the thrust collar by rotating it on the spider. If it varies by more than 0.02 inch (0.5 mm) replace the thrust collar.
	Thrust collar bushing?	Check the thrust collar by rocking it on the spider. If it can tilt more than 1/16 inch (1.6 mm) - as measured at the thrust collar O.D., replace the bushing in the thrust collar.
	Thrust bearing worn?	Check the thrust bearing to see that it is spinning freely. Replace if necessary.
Machine has a perceptible rolling motion while running.	Main shaft?	The main output shaft of the gearbox assembly should be checked for straightness. The main shaft must run straight and cannot be more than 0.003 inch (0.08 mm) out of round at the spider attachment point.
	Yoke?	Check to make sure that both fingers of the yoke press evenly on the wear cap. Replace yoke as necessary.
	Blade Pitch?	Check to ensure that each blade is adjusted to have the same pitch as all other blades. Adjust per maintenance section in manual.

TROUBLESHOOTING (TROWEL)

Troubleshooting (Ride-On Mechanical Trowel) - continued		
Symptom	Possible Problem	Solution
Lights (optional) not working.	Wiring?	Check all electrical connections in the lighting circuit. Verify wiring is in good condition with no shorts. Replace defective wiring or components immediately.
	Lights?	If +12VDC is present at light fixture connector when light switch is activated and light does not turn on, replace light bulb.
	Bad switch?	Check the continuity of light switch. Replace light switch if defective.
	Bad fuse?	Check fuse. Replace fuse if defective.
Retardant spray (optional) not working.	Retardant?	Check retardant level in tank. Fill tank as required.
	Wiring?	Check all electrical connections in the spray pump circuit. Verify wiring is in good condition with no shorts. Replace defective wiring or components immediately.
	Bad switch?	Check the continuity of both left and right spray switches (palm handles). Replace spray switch if defective..
	Bad spray pump?	If +12VDC is present at pump connector when spray switch is activated and pump does not operate, replace spray pump.
	Bad fuse?	Check fuse. Replace fuse if defective.
Steering is unresponsive.	Blade speed out of adjustment?	See section on blade speed adjustment.
	Steering linkage out of adjustment?	Adjust the connecting linkage found at the base of the handle. Contact your MQ field service manager for instructions.
	Worn components?	Check for wear of steering bearings and linkage components. Replace if necessary.
Operating position is uncomfortable.	Seat adjusted for operator?	Adjust seat with lever located on the front of the seat.
Power head on Electric Pitch (optional) not working.	Broken or loose parts?	If the motor runs and the pitch is not affected, parts inside the power head may be loose or broken. Return power head to dealer for service.
	Wiring?	Check all electrical connections and wiring. Check the continuity at the power head unit. Verify that there is voltage present at the power head switch with the key switch in the "on" position.
	Switch?	Check the continuity of the switch. If switch is malfunctioning, replace immediately.
Linkage on Twin Pitch not working.	Crank handles?	Make sure that both crank handles are pushed down as far as possible to ensure that the linkage is engaged.
	Broken part?	Replace all broken parts immediately.
Clutch slipping or sluggish response to engine speed change.	Worn belts?	Replace belt.
	Clutch out of adjustment?	Adjust per instructions in maintenance section of this manual.
	Worn or defective clutch parts?	Replace parts as necessary.
	Worn bearings in gearbox?	Rotate input shaft by hand. If shaft rotates with difficulty, check the input and output shaft bearings. Replace as necessary.
	Worn or broken gears in gearbox?	Verify that the gearbox shaft rotates when the input shaft is rotated. Replace both the worm and worm gear as a set.

TROUBLESHOOTING (ENGINE)

Troubleshooting (Engine)		
Symptom	Possible Problem	Solution
Engine will not start or start is delayed, although engine can be turned over.	No fuel reaching injection pump?	Add fuel. Check entire fuel system.
	Defective fuel pump?	Replace fuel pump.
	Fuel filter clogged?	Replace fuel filter and clean tank.
	Faulty fuel supply line?	Replace or repair fuel line.
	Compression too low?	Check piston, cylinder and valves. Adjust or repair per engine repair manual.
	Fuel pump not working correctly?	Repair or replace fuel pump.
	Oil pressure too low?	Check engine oil pressure.
	Low starting temperature limit exceeded?	Comply with cold starting instructions and proper oil viscosity.
	Defective battery?	Charge or replace battery.
	Air or water mixed in fuel system?	Check carefully for loosened fuel line coupling, loose cap nut, etc.
At low temperatures engine will not start.	Engine oil too thick?	Refill engine crankcase with correct type of oil for winter environment.
	Defective battery?	Replace battery.
Engine fires but stops as soon as starter is switched off.	Fuel filter blocked?	Replace fuel filter.
	Fuel supply blocked?	Check the entire fuel system.
	Defective fuel pump?	Replace fuel pump.
Engine stops by itself during normal operation.	Fuel tank empty?	Add fuel.
	Fuel filter blocked?	Replace fuel filter.
	Defective fuel pump?	Replace fuel pump.
	Mechanical oil pressure shutdown sensor stops the engine due to low oil?	Add oil. Replace low oil shutdown sensor if necessary.
Low engine power, output and speed.	Fuel tank empty?	Add fuel.
	Fuel filter clogged?	Replace fuel filter.
	Fuel tank venting is inadequate?	Ensure tank is adequately vented.
	Leaks at pipe unions?	Check threaded pipe unions. Tape and tighten unions as required.
	Speed control lever does not remain in selected position?	See engine manual for corrective action.
	Engine oil level too full?	Correct engine oil level.
	Injection pump wear?	Use No. 2-D diesel fuel only. Check the fuel injection pump element and delivery valve assembly and replace as necessary.

TROUBLESHOOTING (ENGINE)

Troubleshooting (Engine) - continued		
Symptom	Possible Problem	Solution
Low engine power output and low speed, black exhaust smoke.	Air filter blocked?	Clean or replace air filter.
	Incorrect valve clearances?	Adjust valves per engine specification.
	Malfunction at injector?	See engine manual.
Engine overheats.	Too much oil in engine crankcase?	Drain off engine oil down to upper mark on dipstick.
	Entire cooling air system contaminated or blocked?	Clean cooling air system and cooling fin areas.
	Fan belt broken or elongated?	Change belt or adjust belt tension.
	Coolant insufficient?	Replenish coolant.
	Radiator net or radiator fin clogged with dust?	Clean net or fin carefully.
	Fan, radiator, or radiator cap defective?	Replace defective part.
	Thermostat defective?	Check thermostat and replace if necessary.
	Head gasket defective or water leakage?	Replace parts.

OPERATION MANUAL

HERE'S HOW TO GET HELP

PLEASE HAVE THE MODEL AND SERIAL
NUMBER ON-HAND WHEN CALLING

UNITED STATES

Multiquip Inc.

(310) 537- 3700
6141 Katella Avenue Suite 200
Cypress, CA 90630
E-MAIL: mq@multiquip.com
WEBSITE: www.multiquip.com

CANADA

Multiquip

(450) 625-2244
4110 Industriel Boul.
Laval, Quebec, Canada H7L 6V3
E-MAIL: infocanada@multiquip.com

UNITED KINGDOM

Multiquip (UK) Limited Head Office

0161 339 2223
Unit 2, Northpoint Industrial Estate,
Globe Lane,
Dukinfield, Cheshire SK16 4UJ
E-MAIL: sales@multiquip.co.uk

© COPYRIGHT 2026, MULTIQUIP INC.

Multiquip Inc. and the MQ logo are registered trademarks of Multiquip Inc. and may not be used, reproduced, or altered without written permission. All other trademarks are the property of their respective owners and used with permission.

This manual MUST accompany the equipment at all times. This manual is considered a permanent part of the equipment and should remain with the unit if resold.

DISCLAIMER: Product features, descriptions, and specifications are based on published information at the time of publication and are subject to change at any time without notice. Multiquip Inc. and its affiliates reserve the right to change specifications, features, design, and descriptions of products at any time without notice.



PN: 30039