



# Service Bulletin

## HTX6H Fuel Tank Pickup Line Modification

<b>Product Group:</b> Ride-On Trowels	<b>Date Issued:</b> 05/26/17	<b>Expiration Date:</b> 05/26/18	<b>Service Bulletin No.</b> TR20170512
<b>Bulletin Type</b>  <input checked="" type="checkbox"/> Mandatory <input type="checkbox"/> Information Only <input type="checkbox"/> Recommended Change		<b>Models/Series Affected:</b>  HTX6H SERIES S/N NC2003442 AND BELOW	

<b>Details</b>
<b>Problem:</b> Dirt and debris may be entering the fuel system.
<b>Solution:</b> Install a new fuel tank pickup line with a mesh screen.

**Parts Information**

Item	Part No.	Description	QTY.	Remarks
1	42501	Pickup Line, Fuel Tank	1	
2	22810	Clamp, Fuel 1/2-9/16" OD	1	

**Figure 1. Fuel Tank Pickup Line and Fuel Injection Clamp**

## WORK SAFELY!

Only a qualified service technician with proper training should perform this procedure. Follow all shop safety rules while performing this procedure.

## PREPARATION

1. Make sure the trowel is turned off and **the engine is cool**.
2. Place the trowel in an area free of dirt and debris, and make sure it is on secure level ground.

## REQUIRED TOOLS

- Flat Screwdriver
- 11/16" Open-End Wrench
- Liquid Sealant

## FUEL SAFETY

### DANGER

- **ALWAYS** use extreme caution when working with flammable liquids.
- **DO NOT** smoke around or near the equipment. Fire or explosion can result from fuel vapors or if fuel is spilled on a hot engine.

## BATTERY SAFETY

### DANGER

- **DO NOT** expose the battery to open flames, sparks, cigarettes, etc. The battery contains combustible gases and liquids. If these gases or liquids come into contact with a flame or spark, an explosion could occur.

### CAUTION

- **ALWAYS** disconnect the **NEGATIVE** battery terminal before performing service on the equipment.

## BATTERY DISCONNECTION

1. Remove and set aside the **LEFT** grill guard to gain access to the battery (Figure 2).

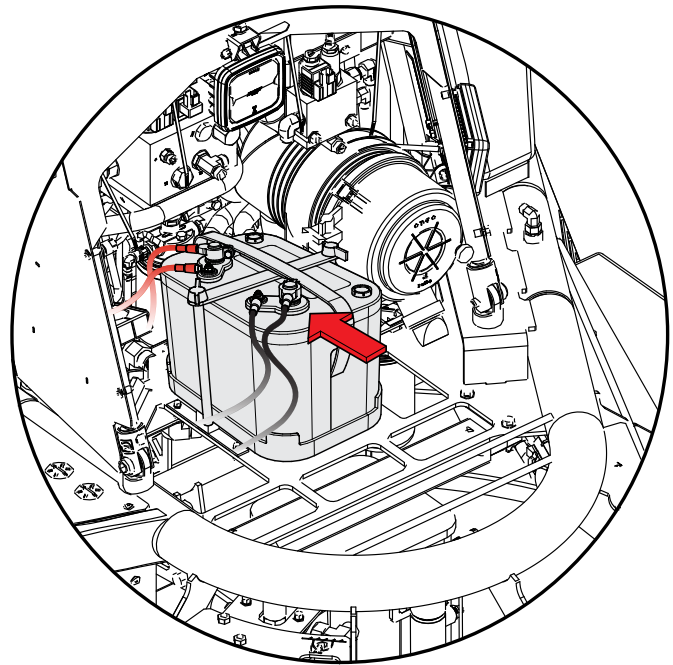

**Figure 2. Battery Disconnection**

2. Disconnect the two negative (**BLACK**) cables from the negative terminal on the battery. See Figure 2.

## FUEL TANK PICKUP LINE INSPECTION

### NOTICE

While performing this procedure, the use of a small container to catch spilled fuel is recommended. **ALWAYS** wipe up any spilled fuel **immediately**.

1. Remove and discard the clamp securing the pre-filter hose to the 90° fitting on the **LEFT** side of the fuel tank (Figure 3).

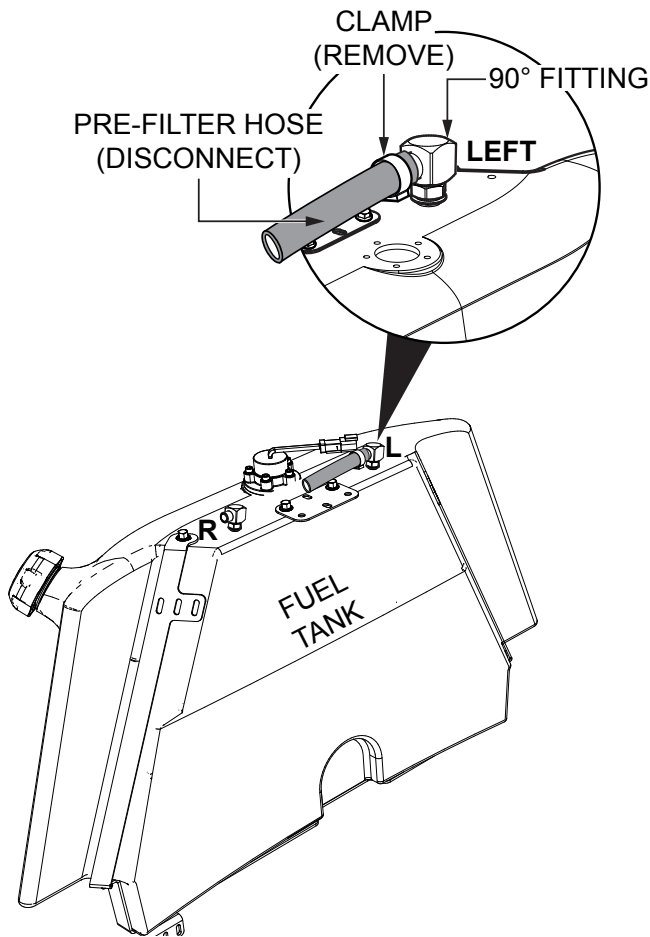

**Figure 3. Pre-Filter Hose Disconnection**

2. Disconnect the pre-filter hose from the 90° fitting on the left side of the fuel tank (Figure 3).
3. Remove the **LEFT** fuel tank pickup line from the fuel tank (Figure 4).

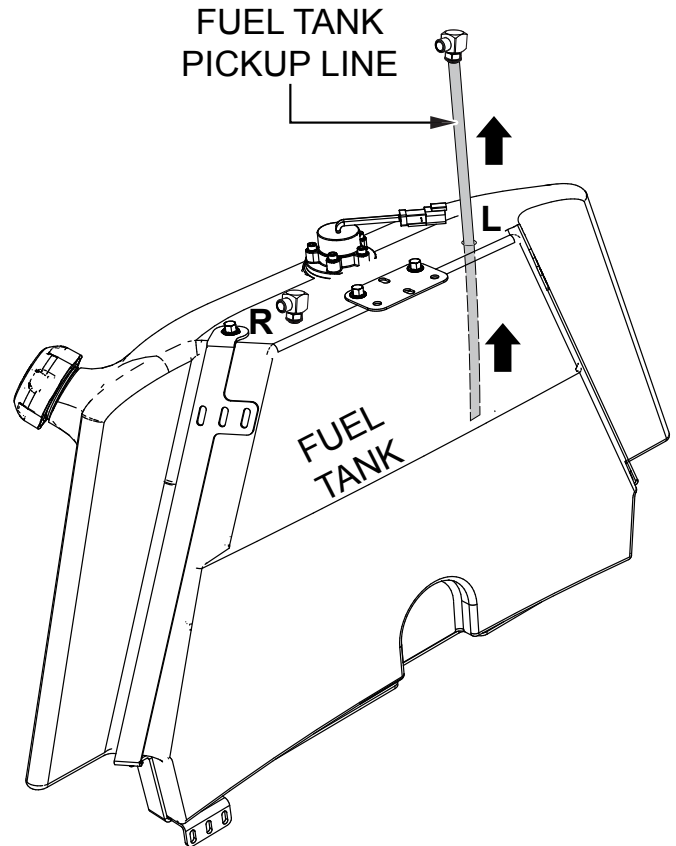

**Figure 4. Fuel Tank Pickup Line Removal (LEFT)**

4. Inspect the fuel tank pickup line (Figure 5). ***If there is a mesh screen*** on the end of the pickup line (Figure 5A), proceed to the “***Existing Fuel Line Reinstallation***” section.

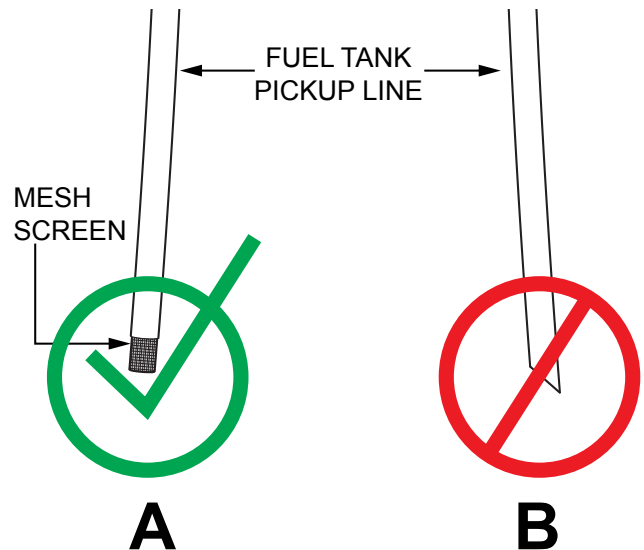
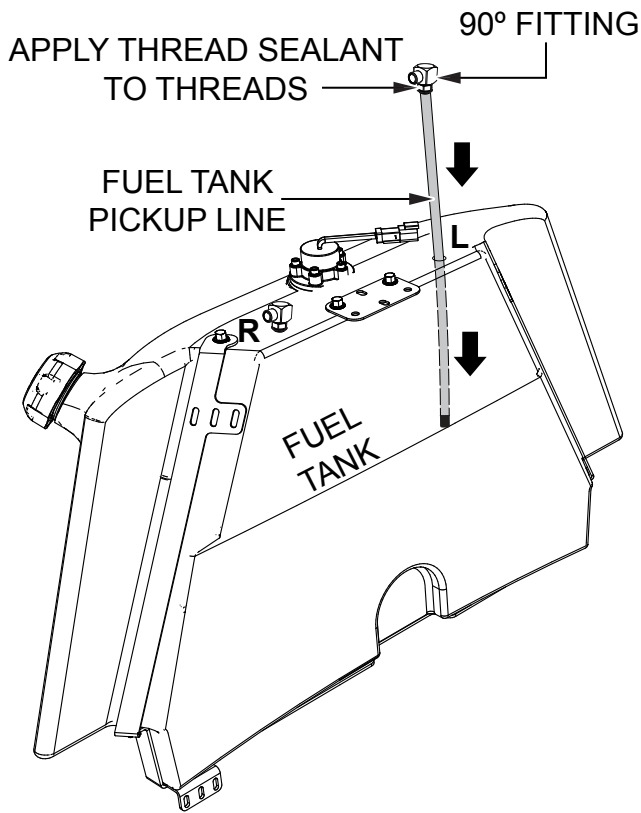

**Figure 5. Fuel Tank Pickup Line Inspection**

5. ***If there is NO mesh screen*** on the end of the fuel tank pickup line (Figure 5B), discard the fuel tank pickup line and proceed to the “***Fuel Line Cleaning***” section.

## EXISTING FUEL LINE REINSTALLATION

1. Apply thread sealant to the threads on the 90° fitting (Figure 6).



**Figure 6. Fuel Tank Pickup Line Reinstallation**

2. Reinstall the fuel tank pickup line and tighten the 90° fitting securely (Figure 6).
3. Place the new hose clamp (P/N 22810) onto the free end of the pre-filter hose. See Figure 7.

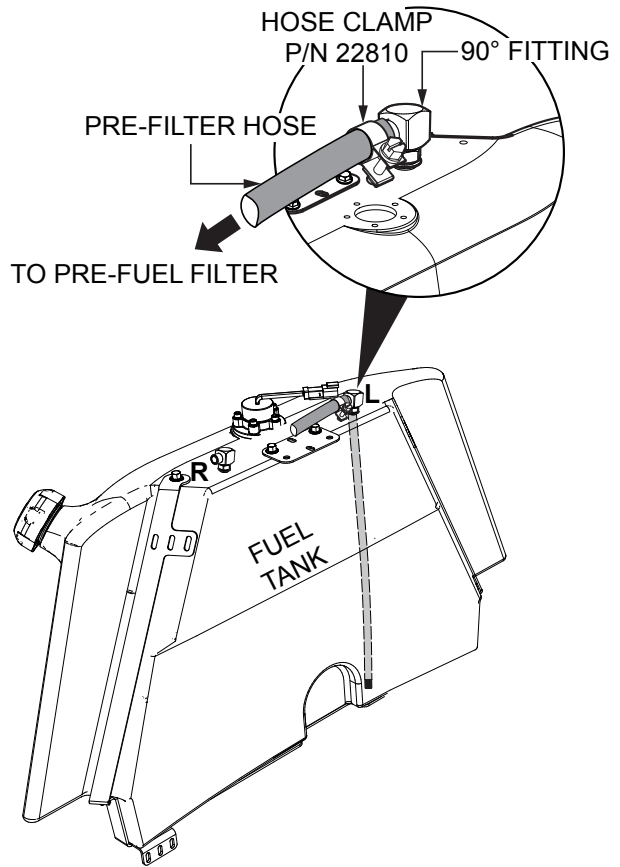

**Figure 7. Pre-Filter Hose Reinstallation**

4. Connect the free end of the pre-filter hose to the 90° fitting on the **LEFT** side of the fuel tank (Figure 7).
5. Secure the pre-filter hose to the 90° fitting with the hose clamp (P/N 22810). See Figure 7.
6. Reconnect the negative (**BLACK**) battery cables.
7. Reinstall the **LEFT** grill guard.

### NOTICE

**DO NOT** proceed to the next section. For any unit with an existing fuel tank pickup line that already has a mesh screen installed, **the procedure is complete.**

## FUEL LINE CLEANING

1. Disconnect the quick-connect fitting securing the pre-filter hose to the pre-fuel filter (Figure 8).

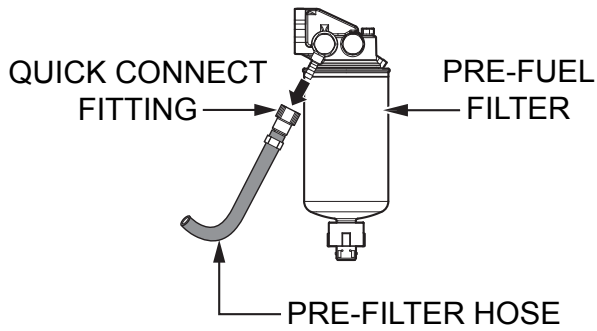

**Figure 8. Pre-Filter Hose Removal**

2. Thoroughly clean the pre-filter hose. Make sure all debris is fully removed from the hose.
3. Inspect the inlet port on the pre-fuel filter (Figure 9) for debris, and clean if necessary.

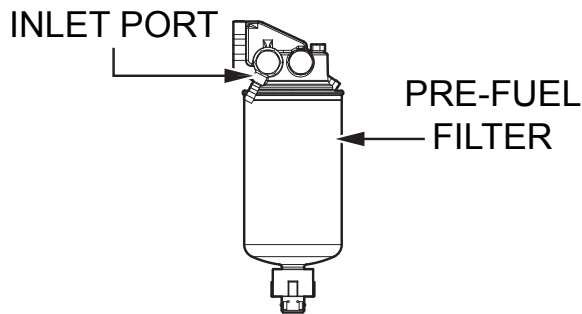

**Figure 9. Pre-Fuel Filter Inlet Port**

## FUEL LINE INSTALLATION

1. Apply thread sealant to the threads of the 90° fitting on the new fuel tank pickup line (P/N 42501). See Figure 10.

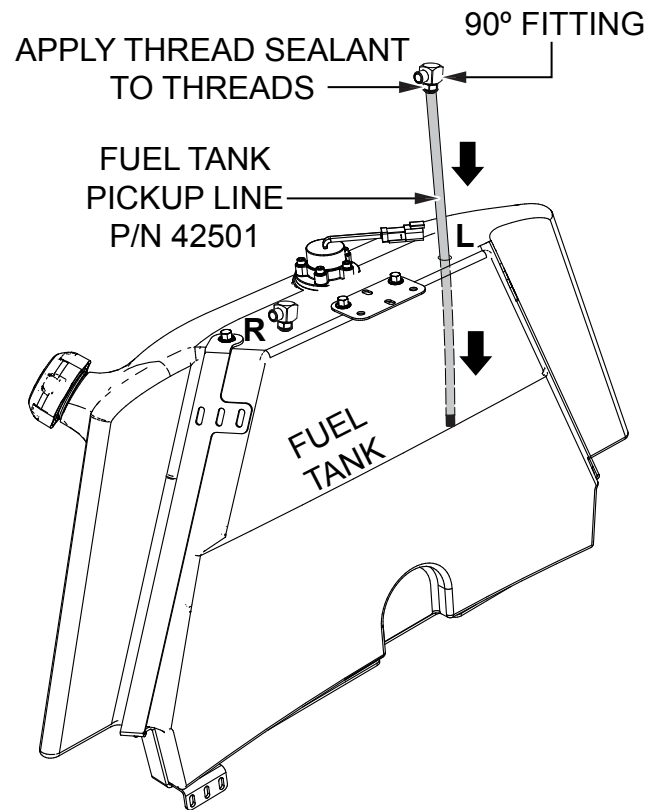

**Figure 10. Fuel Tank Pickup Line Installation**

2. Insert the new fuel tank pickup line (P/N 42501) into the fuel tank and tighten the 90° fitting securely. See Figure 10.
3. Place the new hose clamp (P/N 22810) onto the end of the pre-filter hose opposite the quick-connect fitting. See Figure 11.

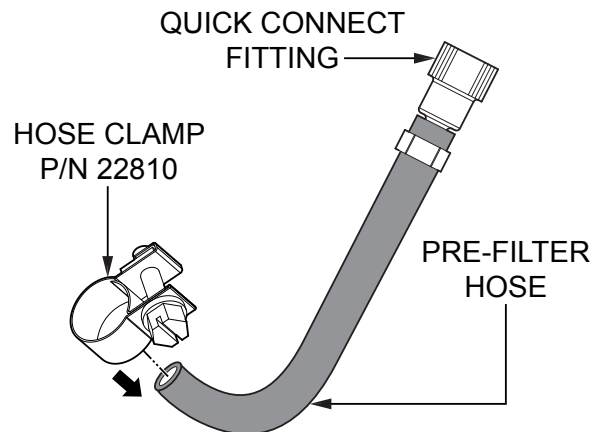

**Figure 11. Hose Clamp Placement**

4. Connect the end of the pre-filter hose with the quick-connect fitting to the inlet side of the pre-fuel filter (Figure 12).

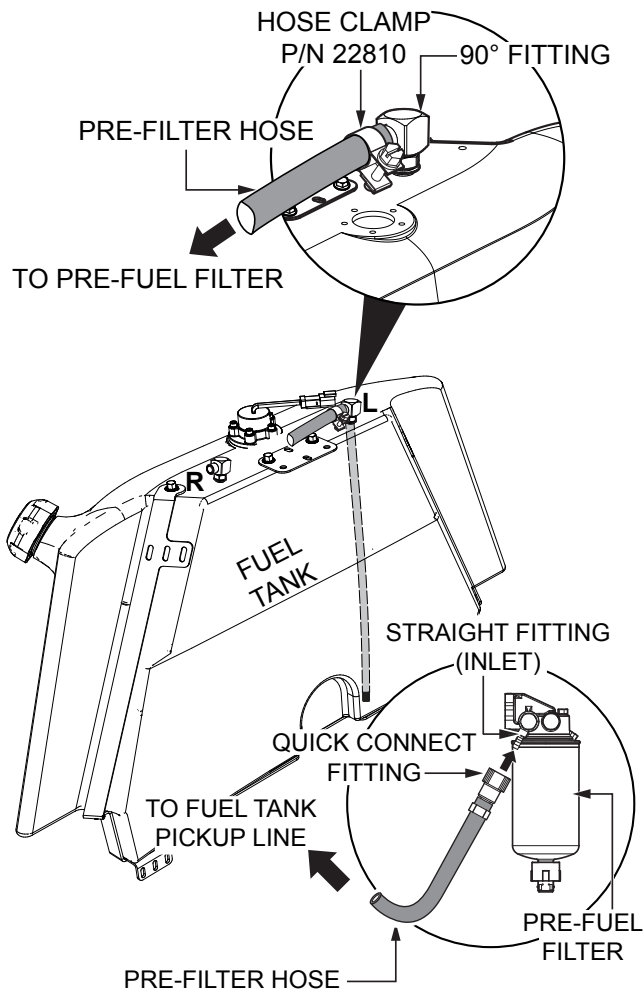

**Figure 12. Pre-Filter Hose Installation**

5. Connect the other end of the pre-filter hose to the 90° fitting on the **LEFT** side of the fuel tank.
6. Secure the pre-filter hose to the 90° fitting with the hose clamp (P/N 22810). See Figure 12.
7. Reconnect the negative (**BLACK**) battery cables.
8. Reinstall the **LEFT** grill guard.





# Service Bulletin

## HTX6H Fuel Tank Pickup Line Modification

### HERE'S HOW TO GET HELP

PLEASE HAVE THE MODEL AND SERIAL  
NUMBER ON-HAND WHEN CALLING

#### UNITED STATES

##### ***Multiquip Corporate Office***

18910 Wilmington Ave.      Tel. (800) 421-1244  
Carson, CA 90746      Fax (310) 537-3927  
Contact: mq@multiquip.com

##### ***Service Department***

800-421-1244  
310-537-3700

##### ***Technical Assistance***

800-478-1244      Fax: 310-943-2238

##### ***MQ Parts Department***

800-427-1244      Fax: 800-672-7877  
310-537-3700

##### ***Warranty Department***

800-421-1244      Fax: 310-943-2249  
310-537-3700

#### CANADA

##### ***Multiquip***

4110 Industriel Boul.      Tel: (450) 625-2244  
Laval, Quebec, Canada H7L 6V3      Tel: (877) 963-4411  
Contact: infocanda@multiquip.com      Fax: (450) 625-8664

#### UNITED KINGDOM

##### ***Multiquip (UK) Limited Head Office***

Unit 2, Northpoint Industrial Estate,      Tel: 0161 339 2223  
Globe Lane,      Fax: 0161 339 3226  
Dukinfield, Cheshire SK16 4UJ  
Contact: sales@multiquip.co.uk

© COPYRIGHT 2017, MULTIQUIP INC.

Multiquip Inc and the MQ logo are registered trademarks of Multiquip Inc. and may not be used, reproduced, or altered without written permission. All other trademarks are the property of their respective owners and used with permission.

The information and specifications included in this publication were in effect at the time of approval for printing. Illustrations, descriptions, references and technical data contained in this document are for guidance only and may not be considered as binding. Multiquip Inc. reserves the right to discontinue or change specifications, design or the information published in this publication at any time without notice and without incurring any obligations.

Your Local Dealer is:

