

PARTS MANUAL



Mikasa **SERIES**
MODEL MTR40SF
TAMPING RAMMER
(ROBIN EH09-2F GASOLINE ENGINE)

Revision #2 (04/26/21)

To find the latest revision of this publication or associated operation manual, visit our website at: www.multiquip.com



THIS MANUAL MUST ACCOMPANY THE EQUIPMENT AT ALL TIMES.

TABLE OF CONTENTS

MTR40SF Rammer

Explanation Of Code In Remarks Column.....	4
Suggested Spare Parts	5

Rammer Component Drawings

Nameplate And Decals.....	6-7
Crankcase And Engine Assembly	8-11
Guide Cylinder Assembly	12-13
Fuel Tank And Handle Assembly.....	14-15
Foot Assembly	16-17
Narrow Foot Assembly (Option)	18-19
Trench Shoe Assembly.....	20-21

Robin EH09-2F Engine Component Drawings

Crankcase Assembly	22-23
Crankshaft And Piston Assembly.....	24-25
Intake And Exhaust Assembly	26-27
Carburetor Assembly	28-29
Air Cleaner Assembly	30-31
Governor And Operation Assembly.....	32-33
Blower Housing Assembly	34-35
Recoil Starter Assembly	36-37
Electric Device Assembly	38-39
Accessories	40-41

NOTICE

Specifications and part numbers are subject to change without notice.

EXPLANATION OF CODE IN REMARKS COLUMN

The following section explains the different symbols and remarks used in the Parts section of this manual. Use the help numbers found on the back page of the manual if there are any questions.

NOTICE

The contents and part numbers listed in the parts section are subject to change **without notice**. Multiquip does not guarantee the availability of the parts listed.

SAMPLE PARTS LIST

NO.	PART NO.	PART NAME	QTY.	REMARKS
1	12345	BOLT	1	INCLUDES ITEMS W/%
2%		WASHER, 1/4 IN.		NOT SOLD SEPARATELY
2%	12347	WASHER, 3/8 IN. ...	1	MQ-45T ONLY
3	12348	HOSE	A/R	MAKE LOCALLY
4	12349	BEARING	1	S/N 2345B AND ABOVE

NO. Column

Unique Symbols — All items with same unique symbol (@, #, +, %, or >) in the number column belong to the same assembly or kit, which is indicated by a note in the “Remarks” column.

Duplicate Item Numbers — Duplicate numbers indicate multiple part numbers, which are in effect for the same general item, such as different size saw blade guards in use or a part that has been updated on newer versions of the same machine.

NOTICE

When ordering a part that has more than one item number listed, check the remarks column for help in determining the proper part to order.

PART NO. Column

Numbers Used — Part numbers can be indicated by a number, a blank entry, or TBD.

TBD (To Be Determined) is generally used to show a part that has not been assigned a formal part number at the time of publication.

A blank entry generally indicates that the item is not sold separately or is not sold by Multiquip. Other entries will be clarified in the “Remarks” Column.

QTY. Column

Numbers Used — Item quantity can be indicated by a number, a blank entry, or A/R.

A/R (As Required) is generally used for hoses or other parts that are sold in bulk and cut to length.

A blank entry generally indicates that the item is not sold separately. Other entries will be clarified in the “Remarks” Column.

REMARKS Column

Some of the most common notes found in the “Remarks” Column are listed below. Other additional notes needed to describe the item can also be shown.

Assembly/Kit — All items on the parts list with the same unique symbol will be included when this item is purchased.

Indicated by:

“INCLUDES ITEMS W/(unique symbol)”

Serial Number Break — Used to list an effective serial number range where a particular part is used.

Indicated by:

“S/N XXXXX AND BELOW”

“S/N XXXX AND ABOVE”

“S/N XXXX TO S/N XXX”

Specific Model Number Use — Indicates that the part is used only with the specific model number or model number variant listed. It can also be used to show a part is NOT used on a specific model or model number variant.

Indicated by:

“XXXXX ONLY”

“NOT USED ON XXXX”

“Make/Obtain Locally” — Indicates that the part can be purchased at any hardware shop or made out of available items. Examples include battery cables, shims, and certain washers and nuts.

“Not Sold Separately” — Indicates that an item cannot be purchased as a separate item and is either part of an assembly/kit that can be purchased, or is not available for sale through Multiquip.

SUGGESTED SPARE PARTS

MTR40SF TAMPING RAMMER WITH ROBIN ROBIN EH09-2F ENGINE

1 to 3 units

Qty.	P/N	Description
1.....	956100040.....	THROTTLE WIRE
3.....	362030030.....	ELEMENT, AIR CLEANER
1.....	361910070.....	CAP, FUEL TANK W/STRAP
3.....	301419750.....	FILTER, IN-LINE FUEL
3.....	0650140380.....	SPARK PLUG
1.....	2745011208.....	ROPE, RECOIL STARTER
3.....	20F3260608.....	ELEMENT, ENGINE

NOTICE

Part numbers on this Suggested Spare Parts list may supersede/replace the part numbers shown in the following parts lists.

NAMEPLATE AND DECALS

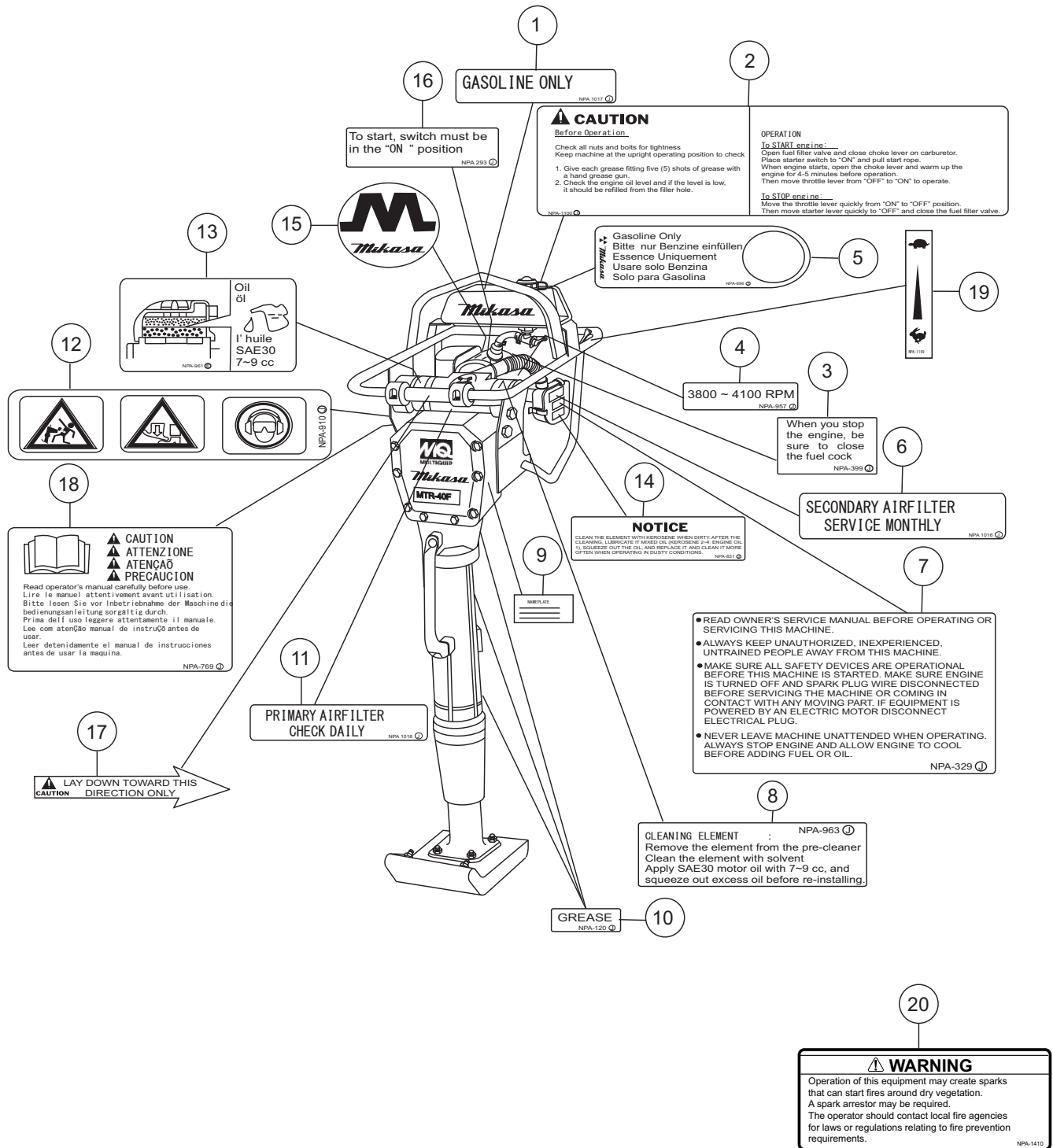

NAMEPLATE AND DECALS

<u>NO.</u>	<u>PART NO.</u>	<u>PART NAME</u>	<u>QTY.</u>	<u>REMARKS</u>
1	920210170	DECAL: GASOLINE ONLY	1	
2	920211000	DECAL: CAUTION (OPERATION)	1	
3	920203990	DECAL: CAUTION (FUEL COCK)	1	
4	920209570	DECAL: ENGINE RPM	1	
5	920208960	DECAL: ELEMENT SET	1	
6	920210160	DECAL: SECONDARY AIR FILTER	1	
7	920203290	DECAL: CAUTION	1	
8	920209630	DECAL: CLEANING ELEMENT	1	
9		PLATE: SERIAL NO.	1CONTACT MQ PARTS DEPT
10	920100120	DECAL: GREASE	3REPLACES 920101200
11	920210180	DECAL: PRIMARY AIR FILTER	1	
12	920209100	DECAL: RAMMER BOOT & HEARING	1	
13	920209610	DECAL: DECAL OIL 7-9 CC	1	
14	920208310	DECAL: CAUTION/OIL INJECT	1	
15	920100240	DECAL: (M-MARK)	1	
16	920202930	DECAL: SWITCH-ON	1	
17	920206910	DECAL: LAYDOWN	1	
18	920207690	DECAL: CAUTION	1	
19	920211690	DECAL: LEVER OPERATION	1	
20	920214100	DECAL: E/G FIRE WARNING	1	

CRANKCASE AND ENGINE ASSY.

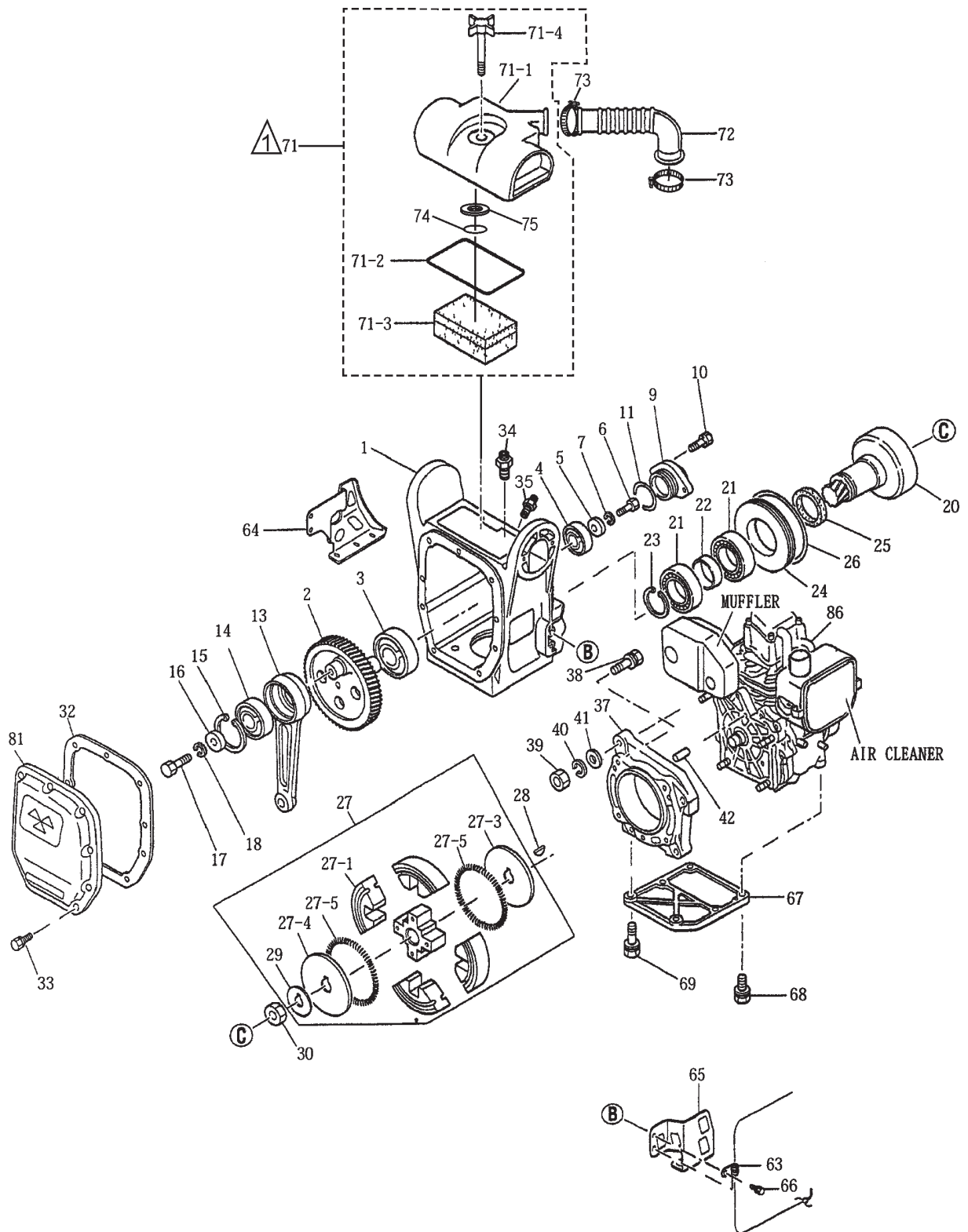

NOTES:

△ AIR CLEANER ASSY., INCLUDES ITEMS WITHIN DASHED LINES EXCEPT FOR ITEMS 74 AND 75.

CRANKCASE AND ENGINE ASSY.

<u>NO.</u>	<u>PART NO.</u>	<u>PART NAME</u>	<u>QTY.</u>	<u>REMARKS</u>
1	305117260	CRANK CASE	1	
2	305343780	CRANK GEAR	1	
3	041006305	BEARING 6305Z	1	
4	041006203	BEARING 6203Z	1	
5	952401450	WASHER 8.5X22X3	1	
6	011208025	BOLT 8X25 T	1	REPLACES 001220825
7	030208200	WASHER, LOCK M8	1	
9	362455660	BEARING COVER	1	
10	011706020	BOLT 6X20 H, SW	2	REPLACES 002210620
11	050100350	O-RING G-35	1	
13	305333090	CONNECTING ROD	1	
14	042006304	BEARING 6304ZZ	1	
15	080100520	STOP RING R-52	1	
16	952400130	WASHER 9304	1	
17	011208025	BOLT 8X25 T	1	REPLACES 001220825
18	030208200	WASHER, LOCK M8	1	
20	303010084	PINION	1	
21	042006007	BEARING 6007ZZ	2	
22	351437750	SPACER	1	
23	080200350	STOP RING S-35	1	
24	351421900	SPACER, CLUTCH DRUM	1	
25	060504010	OIL SEAL VB-40525	1	
26	050300900	O-RING S-90	1	
27	361463840	CLUTCH ASSY. CE120P	1	INCLUDES ITEMS W/ *
27-1*	943020020	CLUTCH SHOE C812	4	
27-3*	943060100	CLUTCH GUIDE (A)	1	
27-4*	943060020	CLUTCH GUIDE (B)	1	
27-5*	943030021	CLUTCH SPRING	2	
28	0053204201	WOODRUFF KEY	1	
29*	301010210	LOCK WASHER, CLUTCH	1	
30	0173120010	LOCK NUT	1	
32	362341610	PACKING, FRONT COVER	1	
33	011706020	BOLT 6X20 H, SW	9	REPLACES 002210620
34	351010050	GREASE FITTING A-MT6X1	1	
35	959010320	GREASE FITTING B-MT6X1	1	
37	2741500123	ADAPTER FLANGE	1	
38	0011408400	BOLT AND WASHER ASSY.	4	
39	020108060	NUT	4	REPLACES 0021808000
40	030208200	WASHER, LOCK	4	REPLACES 0032008000

CRANKCASE AND ENGINE ASSY. (CONT'D.)

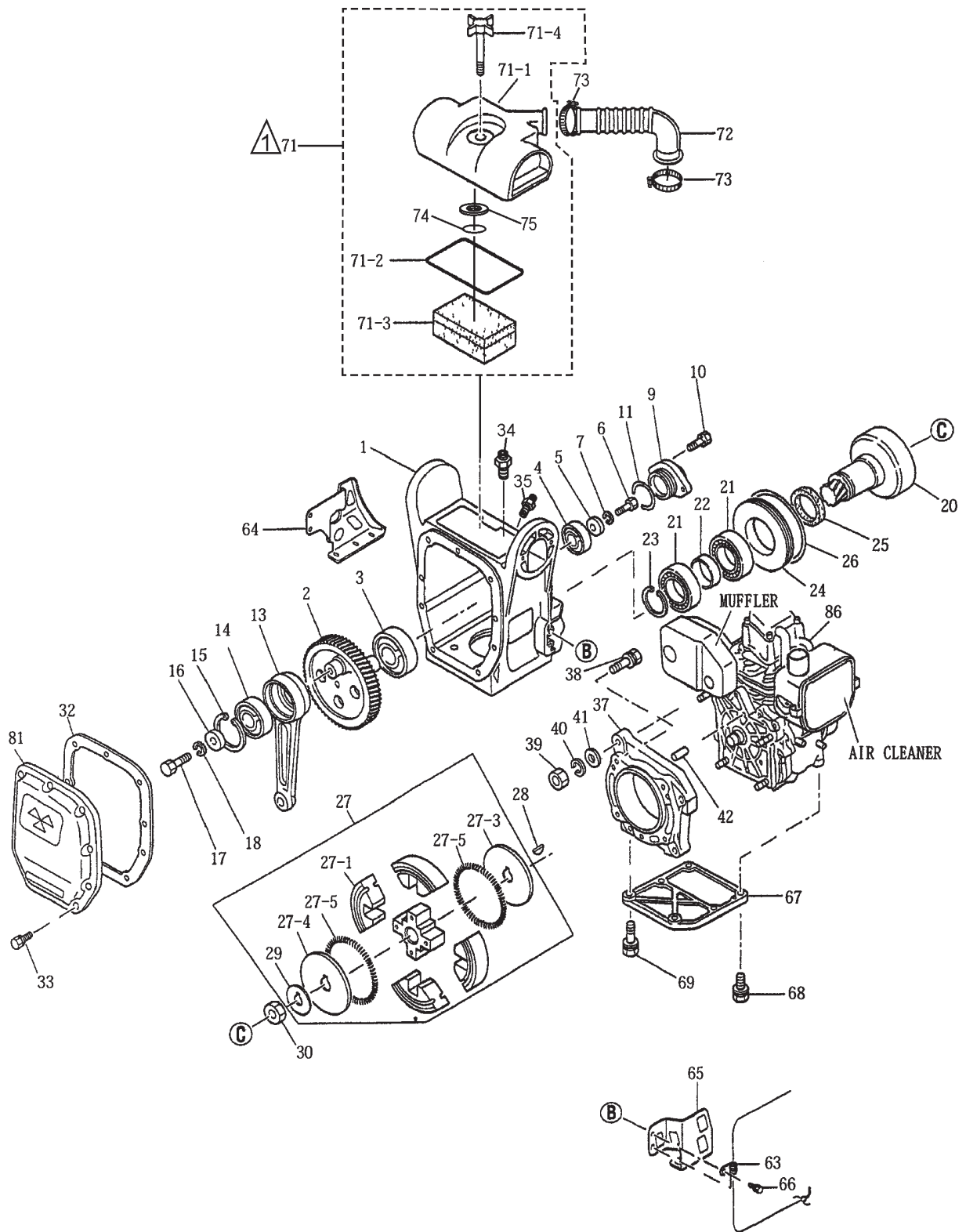

NOTES:

A AIR CLEANER ASSY., INCLUDES
ITEMS WITHIN DASHED LINES
EXCEPT FOR ITEMS 74 AND 75.

CRANKCASE AND ENGINE ASSY. (CONT'D.)

<u>NO.</u>	<u>PART NO.</u>	<u>PART NAME</u>	<u>QTY.</u>	<u>REMARKS</u>
41	0031008000	WASHER	4.....	REPLACES 0031108000
42	0310060020	DOWEL PIN	2	
63	959006120	CLIP (TCP-10509B)	1	
64	362341620	OIL GAUGE PROTECTOR	1	
65	362341630	LINK PROTECTOR	1	
66	3013820	BOLT 8X20 W/FLAT/LOCK WASHER.....	4.....	REPLACES 002400820
67	2741600113	STIFFENER	1	
68	0011408250	BOLT AND WASHER	4	
69	0011408300	BOLT AND WASHER ASSY.	2	
71	362116871	AIR CLEANER ASSY.....	1.....	INCLUDES ITEMS W/#
71-1#	362030011	COVER CP, AIR CLEANER	1	
71-2#	362030020	PACKING, AIR CLEANER	1	
71-3#	362030030	ELEMENT CP, AIR CLEANER	1	
71-4#	362030040	BOLT CP, AIR CLEANER	1	
72	362341210	INTAKE PIPE	1	
73	507010110	CLAMP TC-200	2	
74	050300070	O-RING (7)	1	
75	0401450080	WASHER, FLAT M8.....	1.....	REPLACES 031108160
81	306010020	FRONT COVER	1	
86	911210918	ENGINE ASSY., EH092F	1	

GUIDE CYLINDER ASSY.

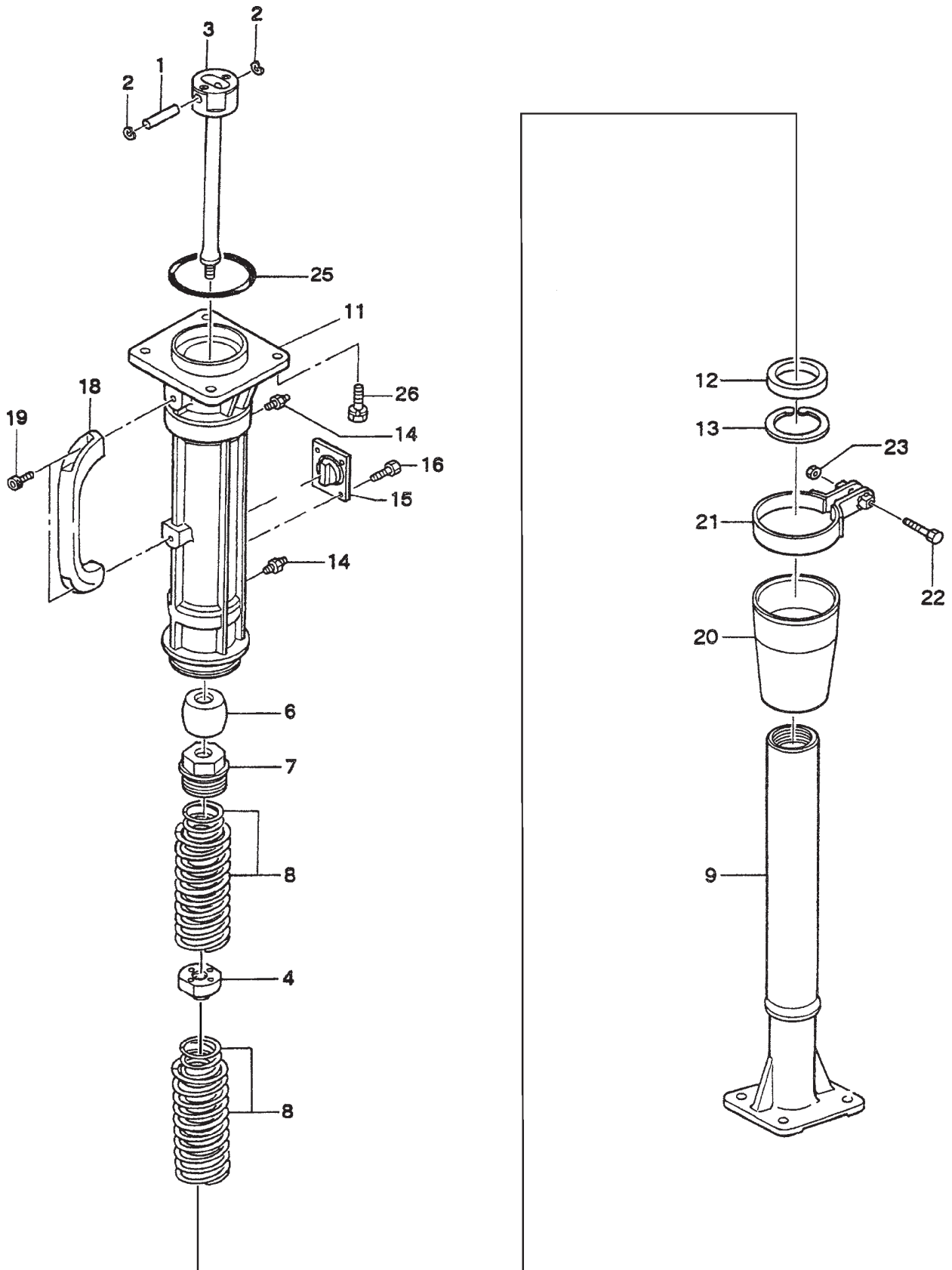

GUIDE CYLINDER ASSY.

<u>NO.</u>	<u>PART NO.</u>	<u>PART NAME</u>	<u>QTY.</u>	<u>REMARKS</u>
1	305464130	PISTON PIN	1	
2	368459920	PISTON PIN PLUG	1	
3	305337980	PISTON ROD, M14	1	
4	305451550	PISTON END, M14	1	
6	305446400	STOPPER, UPPER	1	
7	305446410	CYLINDER CAP	1	
8	305446420	MAIN SPRING	2	
9	305212710	SPRING CYLINDER	1	
11	305112730	GUIDE CYLINDER	1	
12	065105010	DUST SEAL DKI-5367811	1	
13	080510680	STOP RING TH-R-68	1	
14	351010050	GREASE FITTING A-MT6X1	2	
15	305446430	STOPPER	1	
16	001220816	BOLT 8X15 H, SW	4	REPLACES 002200815
18	305446440	GRIP	1	
19	001520815	SOCKET HEAD BOLT 8X15 T	2	
20	305446450	DUST SLEEVE	1	
21	305446460	SLEEVE BAND	1	
22	011208035	BOLT 8X35.....	1	REPLACES 001220835
23	020308060	NUT M8.....	1	REPLACES 020308060
25	050100800	O-RING G-80	1	
26	012210025	BOLT 10X25 H, SW	4	REPLACES 002211025

FUEL TANK AND HANDLE ASSY.

<u>NO.</u>	<u>PART NO.</u>	<u>PART NAME</u>	<u>QTY.</u>	<u>REMARKS</u>
1	306117960	HANDLE	1	
2	351319900	SHOCK ABSORBER	2	
3A	009110007	SOCKET HEAD BOLT 10X20 T	4	
3B	033121009	TOOTHED LOCK WASHER B M10	4	
4	012210020	BOLT 10X20 H, SW	4	REPLACES 002211020
5	939010210	STOPPER RUBBER EH1002	1	
6	030208200	WASHER, LOCK M8	1	
7	020108060	NUT M8	1	REPLACES 020308060
9#	361910070	TANK CAP CP (ORANGE)	1	
10	305910036	FUEL TANK (EVP) ASSY.	1	INCLUDES ITEMS W/#
11#	362458350	SUB CAP	1	
17#	351437785	HOLDER, COCK	1	
18#	954406020	PACKING, FUEL TANK	1	
19	954300720	FUEL COCK ASSY./CVL-08	1	
20#	954406010	STRAINER (#110)	1	
21	011208030	BOLT 8X30 T	2	REPLACES 001220830
22	030208200	WASHER, LOCK M8	2	
23	022710809	NYLON NUT M8	2	
24	952401450	WASHER 8.5X22X3	2	
31#	954404890	FILTER, TANK	1	
32	0561080020	HOSE CLAMP	4	
33	959328404	FUEL HOSE, L=150 EVP	2	
34	301419750	FUEL FILTER CP	1	
41#	363218260	F. TANK 2L (GRAY) EVP	1	
43	362910060	THROTTLE LEVER ASSY.	1	INCLUDES ITEMS W/ *
44*	362341550	THROTTLE BODY	1	
45*	362910090	THROTTLE, GEAR CP. W/BOLT	1	
47*	362455620	SLIDER	1	
48*	362455630	THROTTLE LEVER	1	
49*	050100450	O-RING G-45	1	
50*	050200100	O-RING P-10	1	
51*	031110160	WASHER, FLAT M10	3	
52*	033910230	CONICAL SPRING WASHER	2	
53*	096206006	SOCKET HEAD SCREW 6X6	1	
54	022131008	CAP NUT M10	1	
55	020310080	NUT M10, H=6	1	REPLACES 020410060
56*	014208020	SOCKET HEAD SCREW 8X20	1	REPLACES 096208020
57*	020408050	NUT M8, H=5	2	
58*	956100040	THROTTLE WIRE 620-710	1	
59	011206020	BOLT 6X20T	2	REPLACES 001220620
60	030206150	WASHER, LOCK	2	
61	022130605	CAP NUT M6	2	

FOOT ASSY.

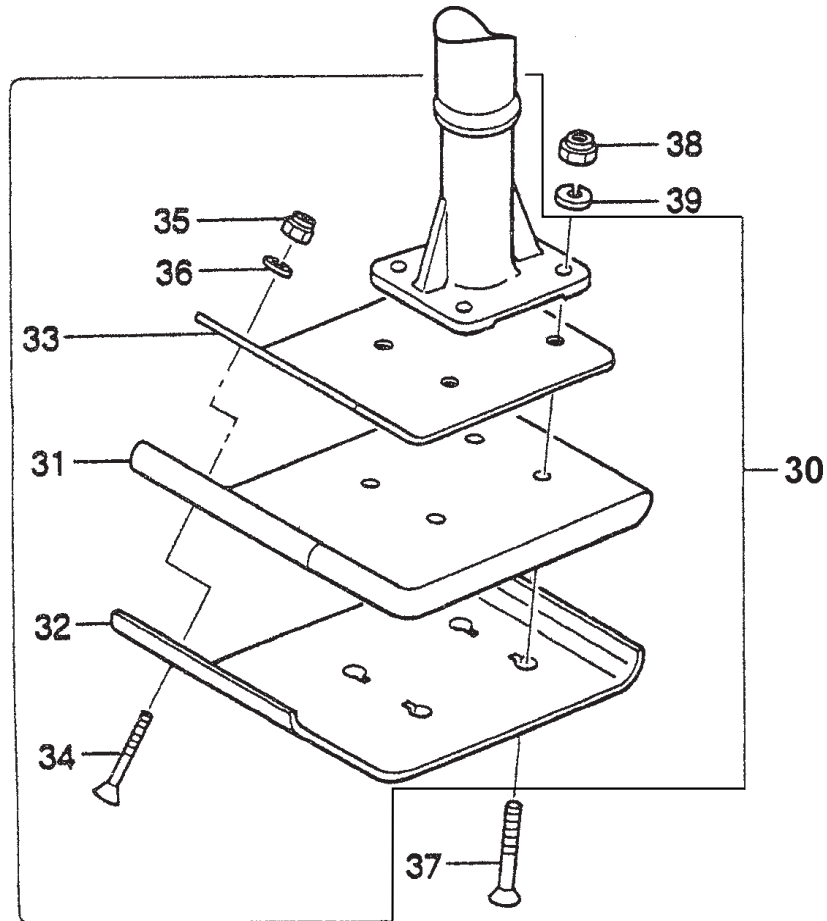

FOOT ASSY.

<u>NO.</u>	<u>PART NO.</u>	<u>PART NAME</u>	<u>QTY.</u>	<u>REMARKS</u>
30	305910050	FOOT ASSY. 150B.....	1.....	INCLUDES ITEMS W/ *
31*	306347930	FOOT 150B	1	
32*	306347960	METAL SHEET 150B	1	
33*	306461630	FOOT COVER	1	
34*	009110033	SUNK HEAD BOLT 10X50 H	2	
35*	021110120	NYLON NUT M10	2.....	REPLACES 022711012
36*	030210250	WASHER, LOCK M10	2	
37	009110034	SUNK HEAD BOLT 12X65 H	4	
38	021112140	NYLON NUT M12	4.....	REPLACES 022711214
39	030212300	WASHER, LOCK M12	4	

NARROW FOOT ASSY. (OPTION)

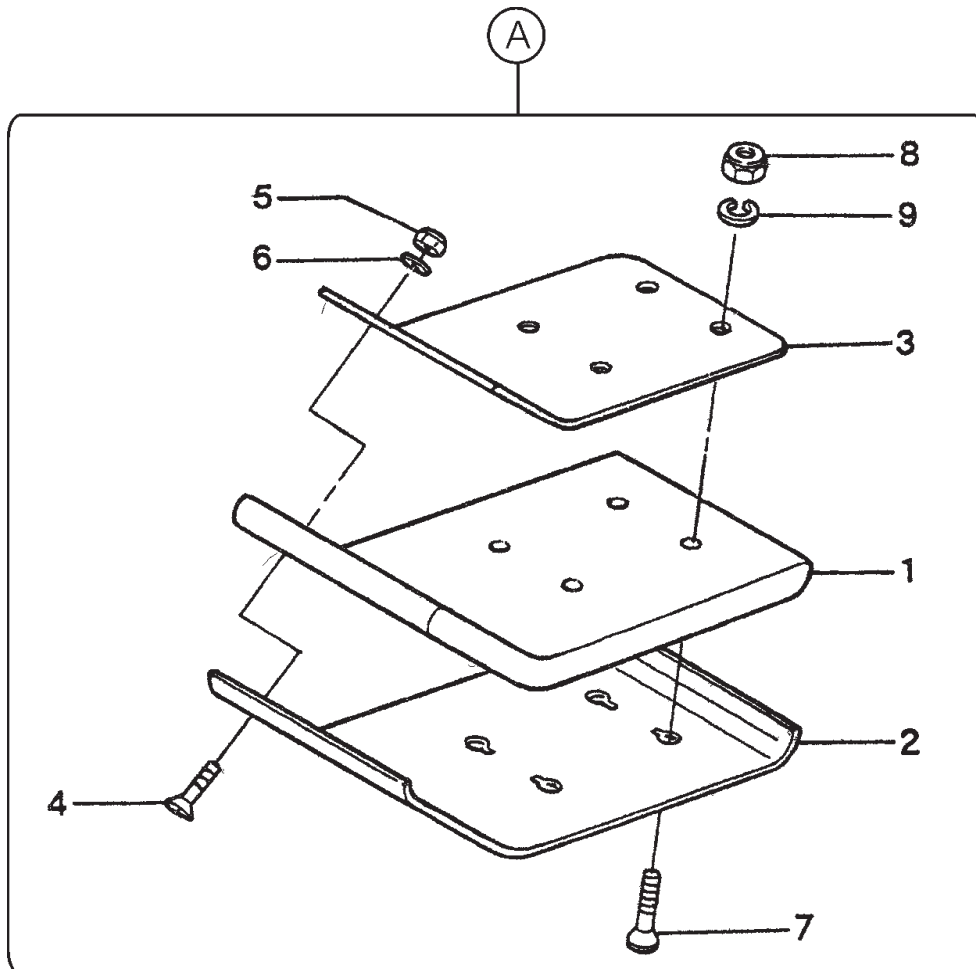

NARROW FOOT ASSY. (OPTION)

<u>NO.</u>	<u>PART NO.</u>	<u>PART NAME</u>	<u>QTY.</u>	<u>REMARKS</u>
A	305910060	FOOT ASSY. 200B.....	1.....	INCLUDES ITEMS W/ *
A	305910070	FOOT ASSY. 100B.....	1.....	INCLUDES ITEMS W/ #
1*	306347940	FOOT 200B.....	1.....	200B
1#	306347920	FOOT 100B.....	1.....	100B
2*	306347970	METAL SHEET 200B.....	1.....	200B
2#	306347950	METAL SHEET 100B.....	1.....	100B
3*	306461630	FOOT COVER	1.....	200B
3#	306461620	FOOT COVER 96B.....	1.....	100B
4*#	015110050	SUNK HEAD BOLT 10X50 H.....	2.....	REPLACES 001611050
5*#	021110120	NYLON NUT M10	2.....	REPLACES 022711012
6*#	030210250	WASHER, LOCK M10	2	
7*#	015112060	SUNK HEAD BOLT 12X60 H.....	4.....	REPLACES 001611252
8*#	021112140	NYLON NUT M12	4.....	REPLACES 022711214
9*#	030212300	WASHER, LOCK M10	4	

TRENCH SHOE ASSY.

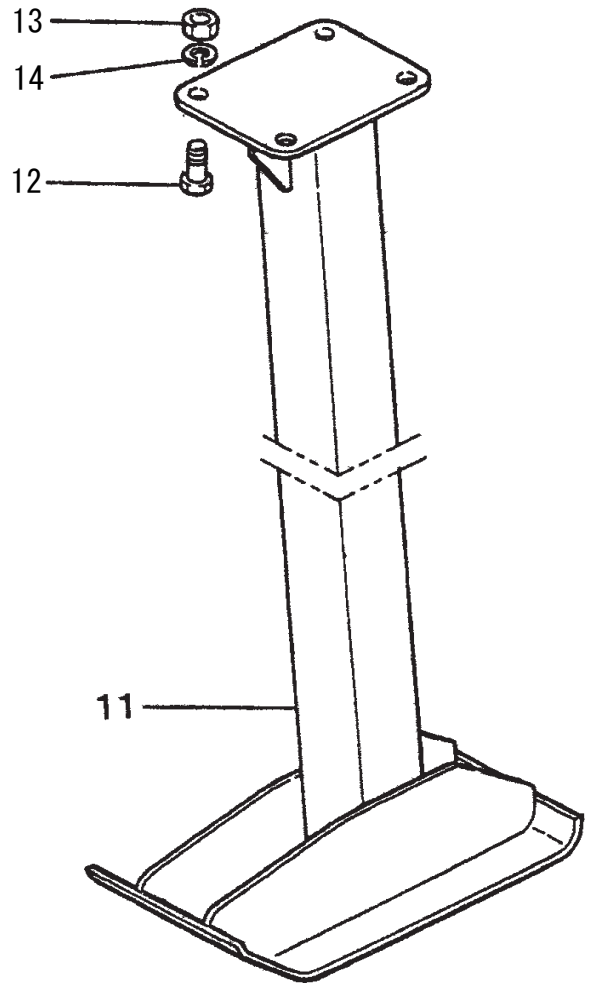

TRENCH SHOE ASSY.

<u>NO.</u>	<u>PART NO.</u>	<u>PART NAME</u>	<u>QTY.</u>	<u>REMARKS</u>
11	305333160	TRENCH SHOE 500H-120B	1	
11	305333170	TRENCH SHOE 800H-120B	1	
11	305334390	TRENCH SHOE 305H-100B	1	
12	012212035	BOLT 12X35 T.....	4.....	REPLACES 001221235
13	020312100	NUT M12	4	
14	0039312000	WASHER, LOCK M12.....	4.....	REPLACES 030212300

ROBIN EH09-2F ENGINE — CRANKCASE ASSY.

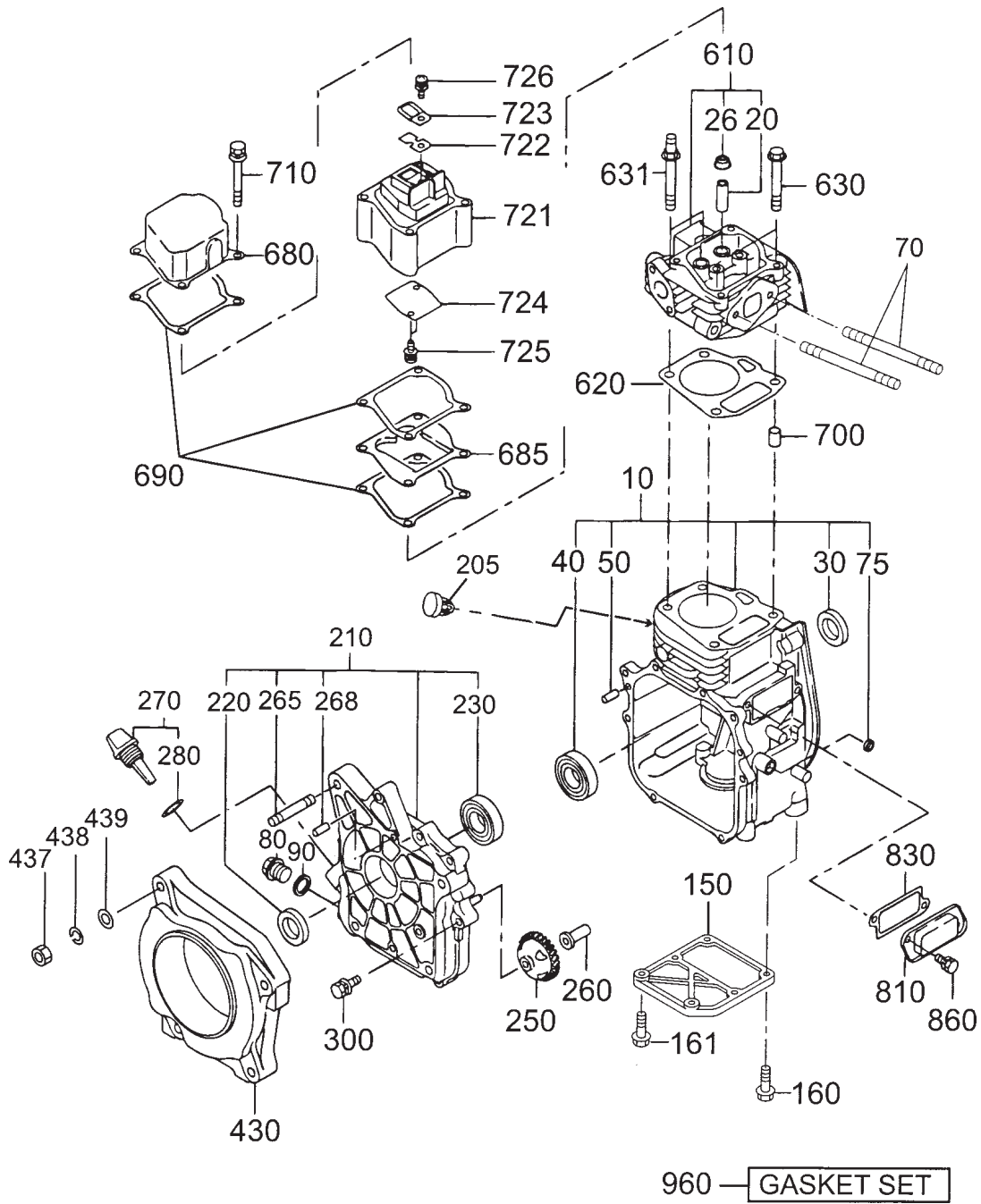

ROBIN EH09-2F ENGINE — CRANKCASE ASSY.

<u>NO.</u>	<u>PART NO.</u>	<u>PART NAME</u>	<u>QTY.</u>	<u>REMARKS</u>
10	20F1010421	CRANKCASE CP	1.....	INCLUDES ITEMS W/#
20&	2371420203	VALVE GUIDE	2	
26&	2771601001	STEM SEAL CP	1	
30#	2096244508	OIL SEAL 20X32X6	1.....	REPLACES 0440200070
40#	0600200110	BALL BEARING, 60074C3	1	
50#	0310060020	DOWEL PIN	2	
70	0105060430	STUD	2	
75#	0440060020	OIL SEAL	1	
80	0401140030	PLUG	1	
90	0211140020	GASKET	1	
150	2741600113	STIFFENER	1	
160	0011408250	BOLT & WASHER	4	
161	0011408300	BOLT & WASHER ASSY.	2	
205	0241090060	GROMMET	1	
210	20F1110131	MAIN BEARING COVER	1.....	INCLUDES ITEMS W/*
220*	0440200110	OIL SEAL 20X32X6	1	
230*	0600200110	BALL BEARING, 6004C3	1	
250	2844500301	GOVERNOR GEAR CP	1	
260	2054190103	GOVERNOR SLEEVE	1	
265*	0013908500	STUD	4	
268*	0310060020	DOWEL PIN	2	
270	2306360111	OIL GAUGE	1.....	INCLUDES ITEMS W/%
280%	0213160020	GASKET	1.....	REPLACES X213160020
300	0130060200	BOLT & WASHER	9	
430	2741500123	ADAPTER FLANGE	1	
437	020108060	NUT	4.....	REPLACES 0021808000
438	030208200	SPRING WASHER.....	4.....	REPLACES 0032008000
439	0031008000	WASHER	4.....	REPLACES 0031108000
610	2841300110	CYLINDER HEAD ASSY.....	1.....	INCLUDES ITEMS W/&
620	2841500113	GASKET HEAD	1	
630	0110080210	FLANGE BOLT	1	
631	0100080410	BOLT	2	
680	2841550203	ROCKER COVER	1	
685	2841450203	OIL SHELTER PLATE	1	
690	2841600703	GASKET, ROCKER COVER	3	
700	2771501103	PIPE KNOCK	2	
710	0110060400	FLANGE BOLT	4	
721	2841560203	BREATHER PLATE	1	
722	2841600103	LEAF VALVE	1	
723	2841600203	BREATHER PLATE	1	
724	2841450103	OIL SHELTER PLATE	1	
725	0131050020	SCREW & WASHER ASSY.	2	
726	0131050020	SCREW & WASHER ASSY.	1	
810	2841700103	COVER CASE	1	
830	2301600613	GASKET TAPPET COVER NA	1	
860	0011406160	BOLT & WASHER ASSY.	2	
960	2849900407	GASKET SET	1	

ROBIN EH09-2F ENGINE — CRANKSHAFT, PISTON ASSY.

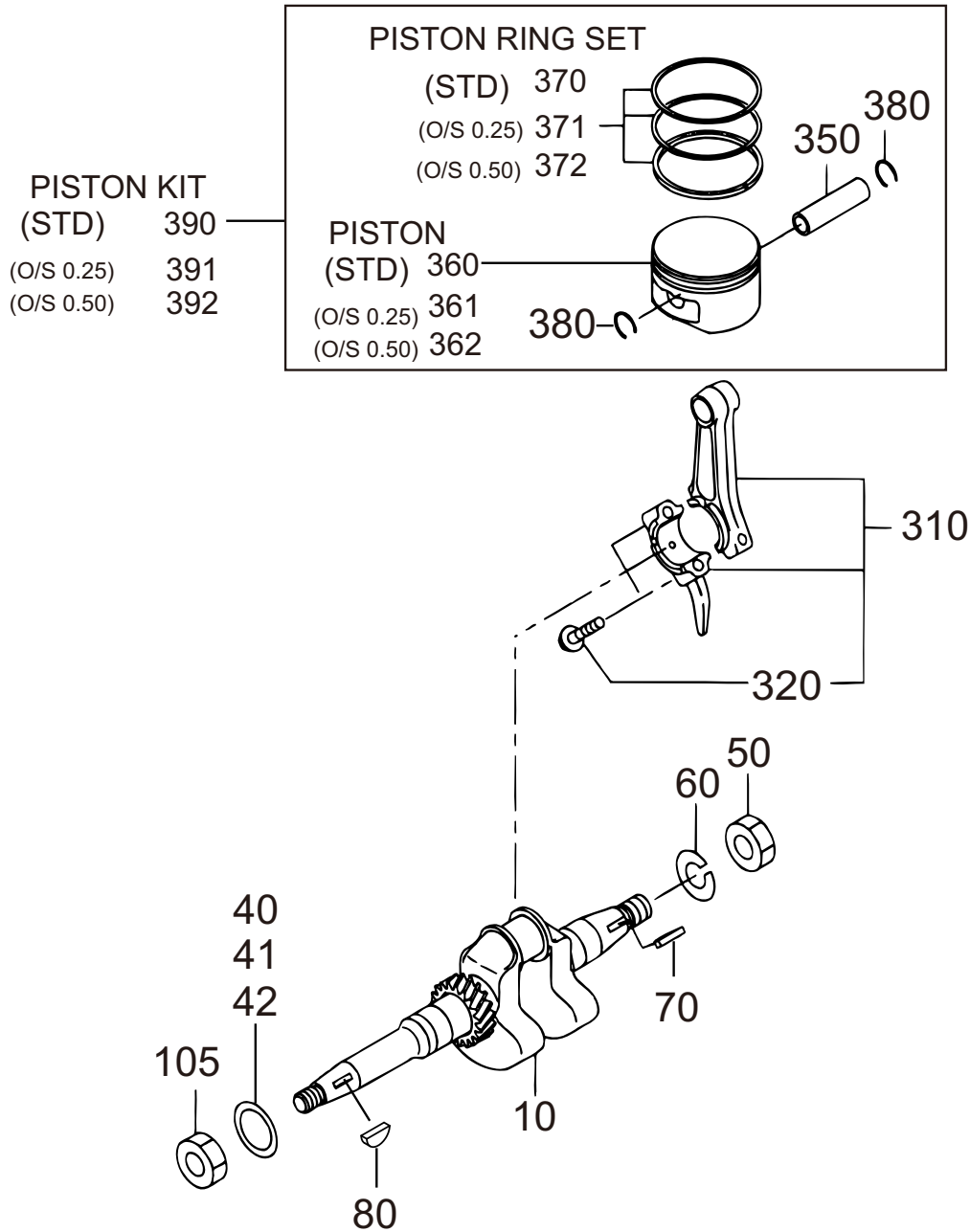

ROBIN EH09-2F ENGINE — CRANKSHAFT, PISTON ASSY.

<u>NO.</u>	<u>PART NO.</u>	<u>PART NAME</u>	<u>QTY.</u>	<u>REMARKS</u>
10	2842030101	CRANKSHAFT CP	1	
40	0230200100	SPACER T=0.8	1	
41	0230200110	SPACER T=1.0	1	
42	0230200120	SPACER T=1.2	1	
50	0021814000	NUT	1	
60	0032014000	SPRING WASHER.....	1	REPLACES 0032012000
70	0053203101	WOODRUFF KEY	1	
80	0053204201	WOODRUFF KEY	1	
105	0173120010	LOCK NUT	1	
310	2842250130	CONNECTING ROD ASSY	1	INCLUDES ITEMS W/%
320%	2842300103	CONNECTING ROD BOLT	2	
350	2302330103	PISTON PIN	1	
360	28423401H3	PISTON	1	
361	28423402H3	PISTON 0.25MM	1	
362	28423403H3	PISTON 0.50MM	1	
370	2842351107	PISTON RING SET	1	
371	2842351207	PISTON RING SET 0.25MM	1	
372	2842351307	PISTON RING SET 0.50MM	1	
380	0565110010	CLIP	2	
390	28427011H7	PISTON KIT/EH09-2/MT, STD	1	
391	28427012H7	PISTON KIT/EH09-2/0.25/MT	1	
392	28427013H7	PISTON KIT/EH09-2/0.50/MT	1	

ROBIN EH09-2F ENGINE — INTAKE, EXHAUST ASSY.

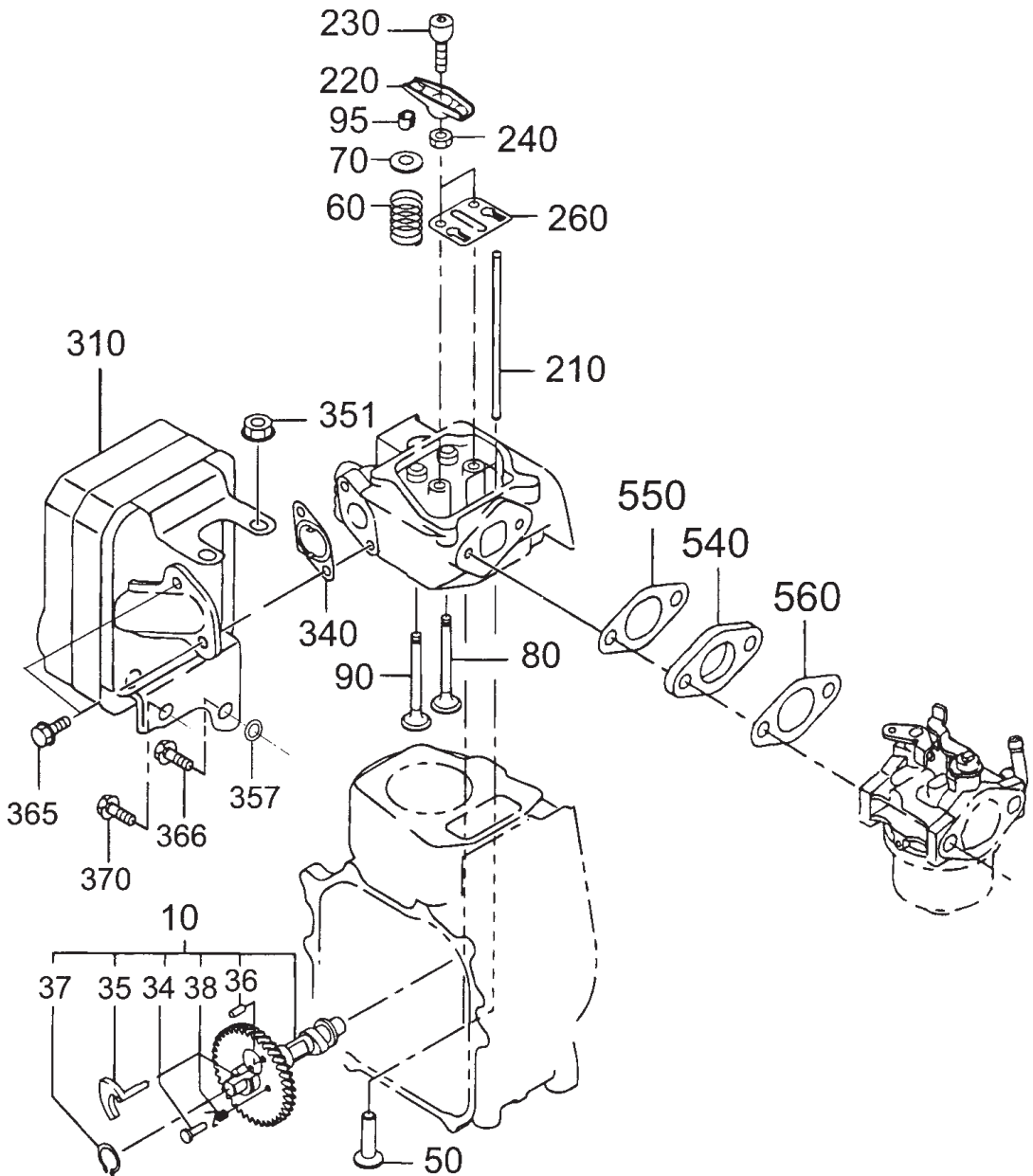

ROBIN EH09-2F ENGINE — INTAKE, EXHAUST ASSY.

<u>NO.</u>	<u>PART NO.</u>	<u>PART NAME</u>	<u>QTY.</u>	<u>REMARKS</u>
10	2843170121	CAMSHAFT CP	1.....	INCLUDES ITEMS W/%
34%	2273860123	PIN (SPRING)	1	
35%	2843640103	RELEASE LEVER	1	
36%	0051904100	SPRING PIN	1	
37%	0031517000	SNAP RING	1	
38%	2743870123	RETURN SPRING	1	
50	2743330103	TAPPET	2	
60	2743360103	VALVE SPRING	2	
70	2743370203	SPRING RETAINER	2	
80	2743340103	INTAKE VALVE	1	
90	2743350103	EXHAUST VALVE	1	
95	13210KA031	COLLET VALVE	4	
210	2743530103	PUSH ROD	2	
220	2843600113	ROCKER ARM	2	
230	2693580103	BOLT (PIVOT)	2	
240	0170060090	NUT	2	
260	2743650103	GUIDE PLATE	1	
310	20F3010501	MUFFLER CP	1	
340	2843520103	GASKET (EXHAUST)	1	
351	0023808000	FLANGE NUT	2	
357	0200080170	WASHER	1	
365	0110060460	FLANGE BOLT	2	
366	0011408160	BOLT & WASHER 8X16	1	
370	0130080240	BOLT & WASHER ASSY.	1	
540	1063292103	INSULATOR	1	
550	2843590213	GASKET (INSULATOR)	1	
560	1573500103	GASKET 2 (INSULATOR)	1	

ROBIN EH09-2F ENGINE — CARBURETOR ASSY.

210

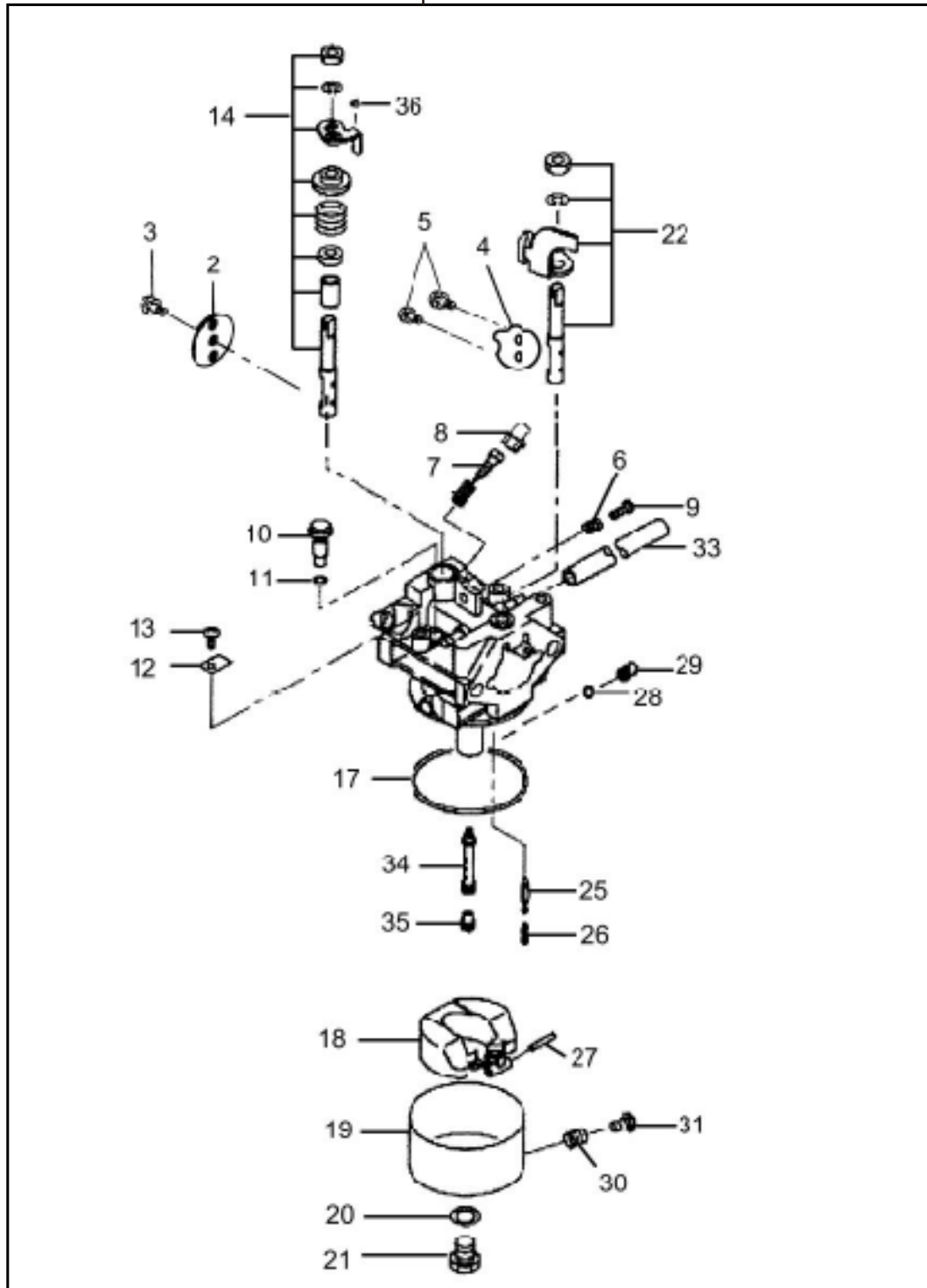

ROBIN EH09-2F ENGINE — CARBURETOR ASSY.

<u>NO.</u>	<u>PART NO.</u>	<u>PART NAME</u>	<u>QTY.</u>	<u>REMARKS</u>
210	2846237200	CARBURETOR ASSY.....	1.....	INCLUDES ITEMS W/#
2#	2306253608	THROTTLE VALVE	1	
3#	2776258008	SCREW 30400	1	
4#	2366252808	CHOKE VALVE	1	
5#	2796235608	SCREW	2	
6#	2306244608	SPRING	1	
9#	2466243508	ADJUST SCREW	1	
10#	2796242108	PILOT JET/EH09-2F	1	
11#	1066238408	O-RING	1	
12#	2936235008	PLATE/EH09-2F	1	
13#	2796235108	SCREW	1	
14#	2936253008	TH, SHAFT/EH09-2F	1	
17#	2366254008	PACKING, CHAMBER 826-42001	1	
18#	2366250508	FLOAT	1	
19#	2936250508	FLOAT. BAY	1	
20#	2366245008	PACKING 826-08003	1	
21#	2376245008	BOLT PV18/695	1	
22#	2936252008	CHOKE SHAFT	1	
25#	1616235208	NEEDLE	1	
26#	2366244508	SPRING	1	
27#	2146251508	FLOAT PIN	1	
29#	2766240008	MAIN JET 30100	1	
30#	2106231808	SPRING	1	
31#	2246245008	SCREW	1	
33#	2846236008	HOSE	1	
34#	2936244018	NOZZLE	1	
35#	2356242508	GUIDE HOLDER	1	
36#	2844550103	BUSH, THRO	1	

ROBIN EH09-2F ENGINE — AIR CLEANER ASSY.

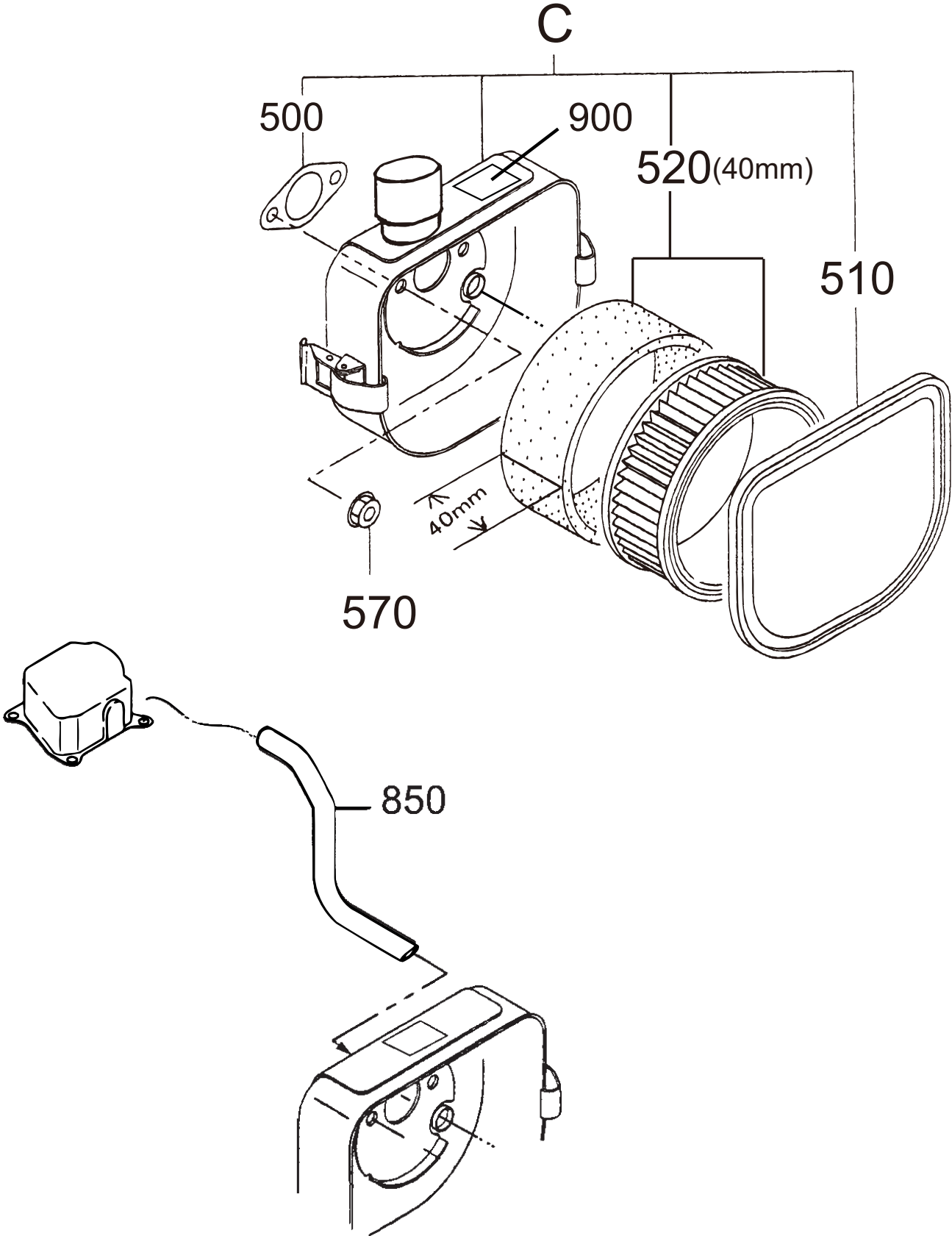

ROBIN EH09-2F ENGINE — AIR CLEANER ASSY.

<u>NO.</u>	<u>PART NO.</u>	<u>PART NAME</u>	<u>QTY.</u>	<u>REMARKS</u>
C	20F3260300	AIR CLEANER ASSY.	1.....	INCLUDES ITEMS W/#
500#	20F3265108	PACKING, CLEANER/09-2F	1	
510#	20F3264108	CLEANER COVER/EH09-2F/MT	1	
520#	20F3260608	ELEMENT ASSY/09-2F/MT	1	
570	0176060030	SELF LOCK NUT	2	
850	2841610403	RUBBER PIPE	1	
900#	0732004430	LABEL, CHOKE	1	

ROBIN EH09-2F ENGINE — GOVERNOR, OPERATION ASSY.

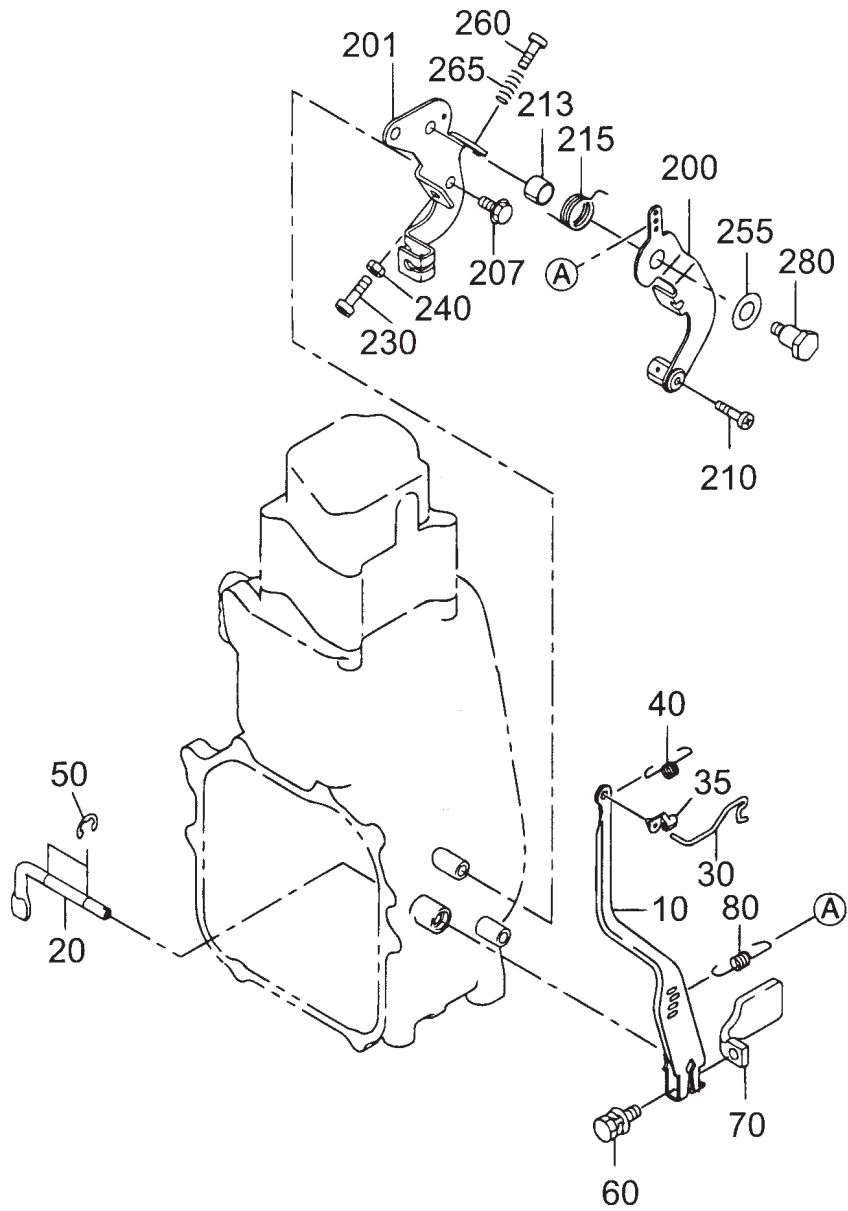

ROBIN EH09-2F ENGINE — GOVERNOR, OPERATION ASSY.

<u>NO.</u>	<u>PART NO.</u>	<u>PART NAME</u>	<u>QTY.</u>	<u>REMARKS</u>
10	2844230403	GOVERNOR LEVER	1	
20	2304220113	GOVERNOR SHAFT	1	REPLACES 2304220103
30	2844270201	GOVERNOR ROD	1	
35	2844560103	LINKAGE BUSHING	1	
40	2844280403	ROD SPRING	1	
50	0031305000	CLIP	2	
60	0011406300	BOLT & WASHER ASSY.	1	
70	2844900201	WEIGHT CP	1	
80	2524250323	GOVERNOR SPRING	1	
200	2304330210	SPEED CONTROL ASSY.	1	
201	2744510101	BASE PLATE	1	
207	957010600800	FLANGE BOLT	2	REPLACES 0110060010
210	0043104140	SCREW, PAN HEAD	1	
213	0230100040	SPACER	1	
215	2264500313	RETURN SPRING	1	
230	0043106300	SCREW	1	
240	020106050	NUT	1	REPLACES 0022706000
255	0217100020	FRICTION WASHER	1	
260	0140040070	SCREW	1	
265	2684500113	CONTROL SPRING	1	
280	2264310301	LINK PIVOT	1	

ROBIN EH09-2F ENGINE — BLOWER HOUSING ASSY.

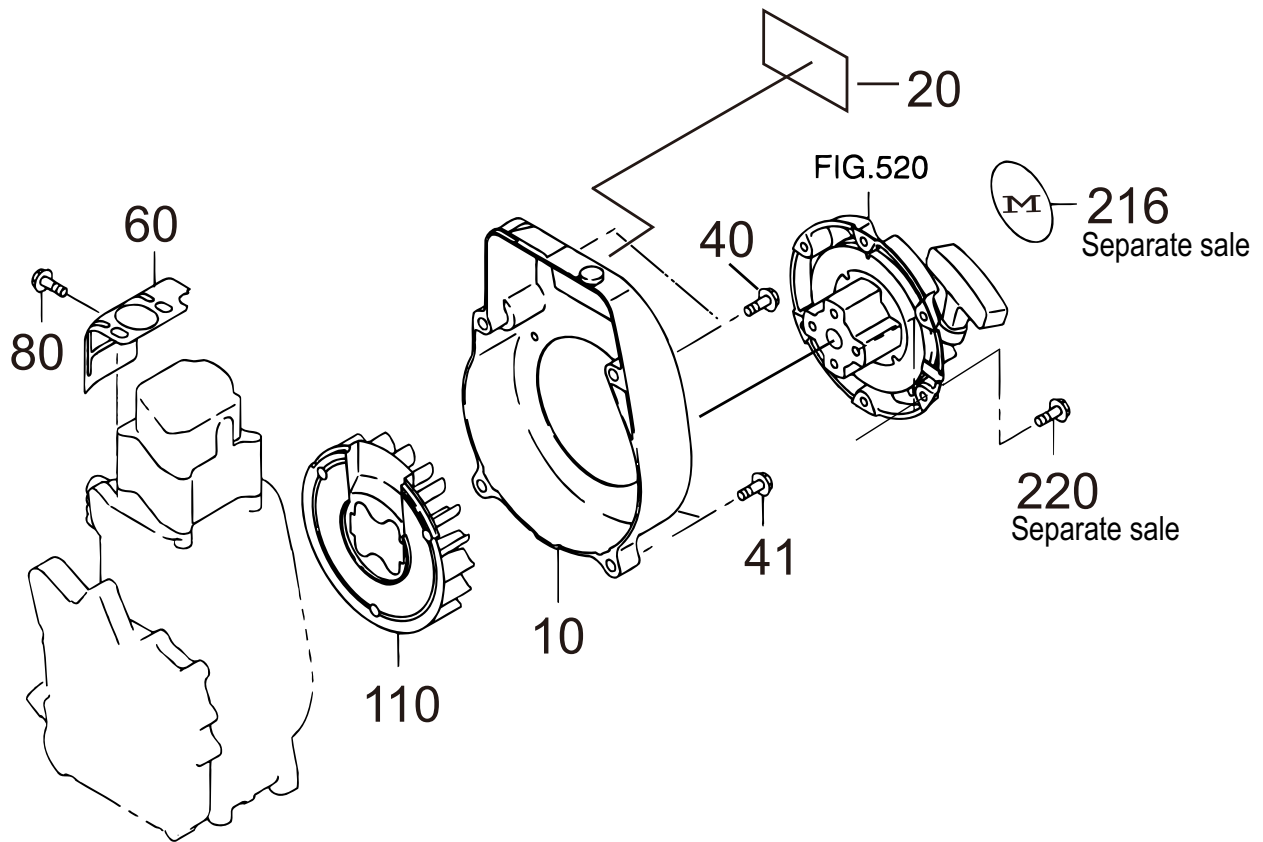

ROBIN EH09-2F ENGINE — BLOWER HOUSING ASSY.

<u>NO.</u>	<u>PART NO.</u>	<u>PART NAME</u>	<u>QTY.</u>	<u>REMARKS</u>
10	20F5110213	BLOWER HOUSING CP	1	
20	2849510203	LABEL	1	
40	0010408350	FLANGE BOLT	1	
41	0010408200	FLANGE BOLT	1	
60	2845260123	CYLINDER BAFFLE	1	
80	957010600800	FLANGE BOLT.....	2.....	REPLACES 0110060010
110	2845410103	COOLING BLOWER	1	
216	920100240	DECAL, M-MARK	1	
220	957010600800	FLANGE BOLT.....	3.....	REPLACES 0110060010

ROBIN EH09-2F ENGINE — RECOIL STARTER ASSY.

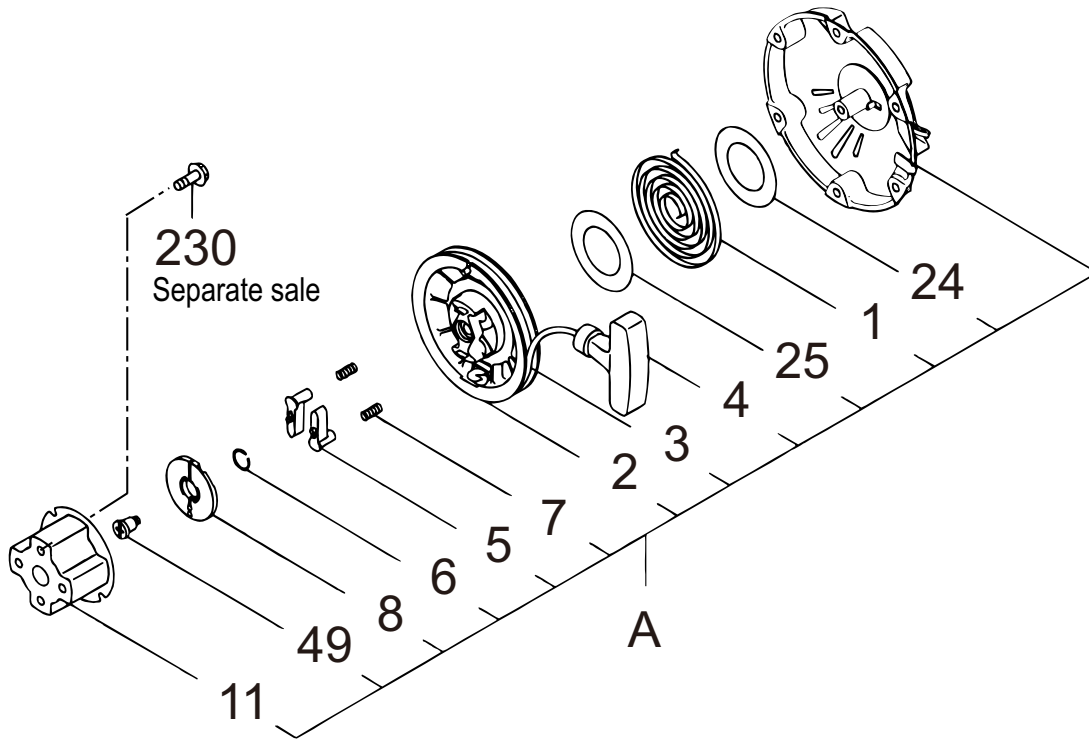

ROBIN EH09-2F ENGINE — RECOIL STARTER ASSY.

<u>NO.</u>	<u>PART NO.</u>	<u>PART NAME</u>	<u>QTY.</u>	<u>REMARKS</u>
A	2845021130	RECOIL STARTER ASSY.	1.....	INCLUDES ITEM W/ *
1*	2745011508	SPIRAL SPRING	1	
2*	2745012018	REEL	1	
3*	2745011208	STARTER ROPE	1	
4*	2615010008	STARTER KNOB	1	
5*	2705012508	RATCHET	2	
6*	2745013108	FRICTION SPRING	1	
7*	2275013508	RETURN SPRING	2	
8*	2705026108	RATCHET GUIDE	1	
11*	2845014508	STARTING PULLEY	1	
24*	2745015208	SLIDE PLATE, B	1	
25*	1315015008	SLIDE PLATE	1	
49*	2275015208	SET SCREW	1	
230*	0110060020	FLANGE BOLT	4	

ROBIN EH09-2F ENGINE — ELECTRIC DEVICE ASSY.

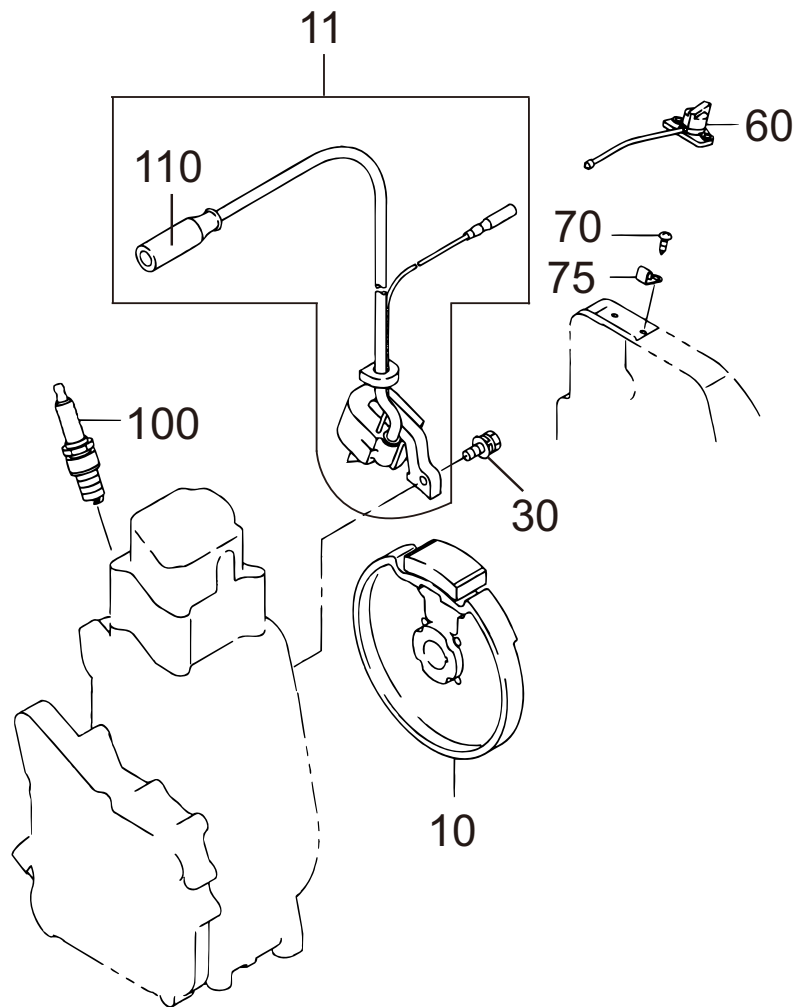

ROBIN EH09-2F ENGINE — ELECTRIC DEVICE ASSY.

<u>NO.</u>	<u>PART NO.</u>	<u>PART NAME</u>	<u>QTY.</u>	<u>REMARKS</u>
10	2847933021	FLYWHEEL CP	1	
11	2847943021	IGNITION COIL CP	1	
30	0011706250	BOLT & WASHER ASSY.	2	
60	0660000471	SWITCH ASSY.	1	
70	0043504120	SCREW & WASHER ASSY.	2	
75	0566030010	CLAMP	1	
100	0650140380	SPARK PLUG	1	
110	2847510203	SPARK PLUG CAP	1	

ROBIN EH09-2F ENGINE — ACCESSORIES

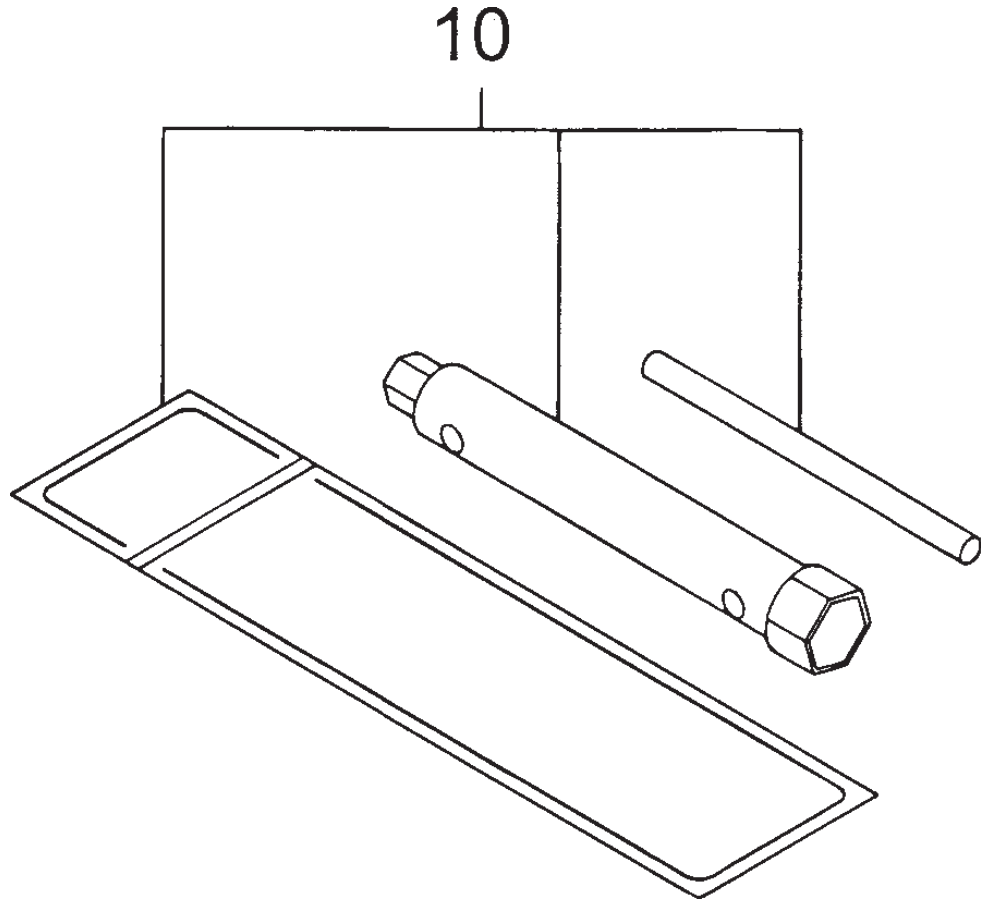

ROBIN EH09-2F ENGINE — ACCESSORIES

<u>NO.</u>	<u>PART NO.</u>	<u>PART NAME</u>	<u>QTY.</u>	<u>REMARKS</u>
10	2269030710	ACCESSORY TOOL KIT	1	

PARTS MANUAL

HERE'S HOW TO GET HELP

PLEASE HAVE THE MODEL AND SERIAL
NUMBER ON-HAND WHEN CALLING

UNITED STATES

Multiquip Inc.

(310) 537- 3700
6141 Katella Avenue Suite 200
Cypress, CA 90630
E-MAIL: mq@multiquip.com
WEBSITE: www.multiquip.com

CANADA

Multiquip

(450) 625-2244
4110 Industriel Boul.
Laval, Quebec, Canada H7L 6V3
E-MAIL: infocanada@multiquip.com

UNITED KINGDOM

Multiquip (UK) Limited Head Office

0161 339 2223
Unit 2, Northpoint Industrial Estate,
Globe Lane,
Dukinfield, Cheshire SK16 4UJ
E-MAIL: sales@multiquip.co.uk

© COPYRIGHT 2021, MULTIQUIP INC.

Multiquip Inc, the MQ logo are registered trademarks of Multiquip Inc. and may not be used, reproduced, or altered without written permission. All other trademarks are the property of their respective owners and used with permission.

This manual MUST accompany the equipment at all times. This manual is considered a permanent part of the equipment and should remain with the unit if resold.

The information and specifications included in this publication were in effect at the time of approval for printing. Illustrations, descriptions, references and technical data contained in this manual are for guidance only and may not be considered as binding. Multiquip Inc. reserves the right to discontinue or change specifications, design or the information published in this publication at any time without notice and without incurring any obligations.

Your Local Dealer is:

